

AlphaPC 164SX Motherboard Windows NT

User's Manual

Order Number: EC-R57DB-TE

Revision/Update Information: This is a revised document. It supersedes the *AlphaPC 164SX Motherboard Windows NT User's Manual*, EC-R57DA-TE.

October 1998

The information in this publication is subject to change without notice.

COMPAQ COMPUTER CORPORATION SHALL NOT BE LIABLE FOR TECHNICAL OR EDITORIAL ERRORS OR OMISSIONS CONTAINED HEREIN, NOR FOR INCIDENTAL OR CONSEQUENTIAL DAMAGES RESULTING FROM THE FURNISHING, PERFORMANCE, OR USE OF THIS MATERIAL. THIS INFORMATION IS PROVIDED "AS IS" AND COMPAQ COMPUTER CORPORATION DISCLAIMS ANY WARRANTIES, EXPRESS, IMPLIED OR STATUTORY AND EXPRESSLY DISCLAIMS THE IMPLIED WARRANTIES OF MERCHANTABILITY, FITNESS FOR PARTICULAR PURPOSE, GOOD TITLE AND AGAINST INFRINGEMENT.

This publication contains information protected by copyright. No part of this publication may be photocopied or reproduced in any form without prior written consent from Compaq Computer Corporation.

©1998 Compaq Computer Corporation. All rights reserved. Printed in U.S.A.

AlphaPC, COMPAQ, DIGITAL, the Compaq logo, and the DIGITAL logo registered in United States Patent and Trademark Office.

Cypress and hyperCache are trademarks of Cypress Semiconductor Corporation.

GRAFOIL is a registered trademark of Union Carbide Corporation.

Linux is a registered trademark of Linus Torvalds in the United States and other countries.

Microsoft, MS-DOS, Windows, and Windows 95 are registered trademarks and Windows NT is a trademark of Microsoft Corporation.

SMC is a registered trademark of Standard Microsystems Corporation.

Other product names mentioned herein may be trademarks and/or registered trademarks of their respective companies.

Contents

1 About This Manual

1.1	Manual Conventions and Terminology	1-1
-----	--	-----

2 Features of the AlphaPC 164SX Motherboard

2.1	Power Requirements	2-4
2.2	Environmental Requirements	2-4
2.3	Physical Parameters	2-5
2.3.1	ATX Hole Specification	2-6
2.3.2	ATX I/O Shield Requirements	2-7

3 AlphaPC 164SX Switch Configuration

3.1	Password Bypass (CF2)	3-1
3.2	Mini-Debugger (CF3)	3-1
3.3	CPU Speed Selection (CF[6:4])	3-1
3.4	Fail-Safe Booter (CF7)	3-2

4 AlphaPC 164SX Connector Pinouts

4.1	PCI Bus Connector Pinouts	4-1
4.2	ISA Expansion Bus Connector Pinouts	4-3
4.3	SDRAM DIMM Connector Pinouts	4-4
4.4	EIDE Drive Bus Connector Pinouts	4-5
4.5	Diskette (Floppy) Drive Bus Connector Pinouts	4-6
4.6	Parallel Bus Connector Pinouts	4-6
4.7	COM1/COM2 Serial Line Connector Pinouts	4-7
4.8	Keyboard/Mouse Connector Pinouts	4-7
4.9	SRAM Test Data Input Connector Pinouts	4-8
4.10	Input Power Connector Pinouts	4-8

4.11	Enclosure Fan Power Connector Pinouts	4-8
4.12	Microprocessor Fan Power Connector Pinouts	4-9
4.13	Soft Power Connector Pinouts	4-9
4.14	Multipurpose Connector Pinouts	4-9

5 Memory and Microprocessor Configuration

5.1	Configuring SDRAM Memory	5-1
5.2	Upgrading SDRAM Memory	5-2
5.3	Increasing Microprocessor Speed	5-3
5.3.1	Preparatory Information	5-3
5.3.2	Required Tools	5-3
5.3.3	Removing the 21164PC Microprocessor	5-4
5.3.4	Installing the 21164PC Microprocessor	5-4

6 Interrupts and ISA Bus Addresses

6.1	Interrupts	6-1
6.2	ISA I/O Address Map	6-2

7 Configuring for Windows NT

7.1	AlphaBIOS	7-1
7.1.1	AlphaBIOS Conventions	7-2
7.1.2	Starting the AlphaBIOS Setup Program	7-2
7.1.3	Upgrading AlphaBIOS	7-3
7.1.4	Performing CMOS Setup Tasks	7-4
7.1.5	Setting Up Your Hard Disk	7-4
7.1.6	Displaying Your System Configuration	7-5
7.1.7	Running a Maintenance Program	7-7
7.2	Installing the Windows NT Operating System	7-8
7.2.1	Requirements	7-9
7.2.2	Before Installing Windows NT	7-9
7.2.3	Starting Windows NT Setup	7-10

8 Troubleshooting

8.1	Password Bypass	8-1
8.2	Hardware Startup	8-1
8.3	Beep Codes	8-2
8.4	Post Codes	8-2
8.5	Fail-Safe Booter	8-3

8.6	Windows NT Startup	8-5
-----	------------------------------	-----

9 Battery Recycle/Disposal Information

A Support, Products, and Documentation

A.1	Customer Support	A-1
A.2	Supporting Products	A-2
A.2.1	Memory	A-2
A.2.2	Thermal Products	A-2
A.2.3	Power Supply	A-2
A.2.4	Enclosure	A-3
A.3	Associated Documentation	A-3

Figures

2-1	AlphaPC 164SX Switch/Connector/Component Location	2-2
2-2	ATX Hole Specification	2-6
2-3	ATX I/O Shield Dimensions	2-7
3-1	AlphaPC 164SX Configuration Switches	3-2
4-1	Multipurpose Connector Pinouts	4-10
5-1	Fan/Heat-Sink Assembly	5-5
7-1	AlphaBIOS Boot Screen	7-3
7-2	Display System Configuration	7-6
7-3	Run Maintenance Program Submenu	7-7
7-4	Entering the Program Name	7-8

Tables

2-1	AlphaPC 164SX Features	2-1
2-2	AlphaPC 164SX Switch/Connector/Component List	2-3
2-3	Power Supply DC Current Requirements	2-4
2-4	AlphaPC 164SX Motherboard Environmental Requirements	2-5
4-1	PCI Bus Connector Pinouts	4-1
4-2	ISA Expansion Bus Connector Pinouts (J22, J23)	4-3
4-3	SDRAM DIMM Connector Pinouts (J7 through J10)	4-4
4-4	EIDE Drive Bus Connector Pinouts (J5, J6)	4-5
4-5	Diskette (Floppy) Drive Bus Connector Pinouts (J11)	4-6
4-6	Parallel Bus Connector Pinouts (J13)	4-6
4-7	COM1/COM2 Serial Line Connector Pinouts (J3)	4-7
4-8	Keyboard/Mouse Connector Pinouts (J4)	4-7
4-9	SRAM Test Data Input Connector Pinouts (J21)	4-8
4-10	Input Power Connector Pinouts (J2)	4-8
4-11	Enclosure Fan (+12 V dc) Power Connector Pinouts (J16)	4-8
4-12	Microprocessor Fan Power Connector Pinouts (J14)	4-9
4-13	Soft Power Connector Pinouts (J1)	4-9
4-14	Multipurpose Connector Pinouts (J20)	4-9
5-1	AlphaPC 164SX SDRAM Memory Configurations	5-2
6-1	ISA Interrupts	6-1
6-2	ISA I/O Address Map	6-2
7-1	Action Keys	7-2
7-2	CMOS Setup Tasks	7-4
8-1	Beep Codes	8-2
8-2	Post Codes	8-2

About This Manual

This manual describes the AlphaPC 164SX motherboard, a board for computing systems based on the Alpha 21164PC microprocessor and the companion 21174 core logic chip. It describes the motherboard's features and how to set its configuration switches. This manual helps users to install and populate the AlphaPC 164SX motherboard with memory boards and peripheral cards.

1.1 Manual Conventions and Terminology

The following conventions are used in this manual.

Caution: Cautions indicate potential damage to equipment, software, or data.

Note: Notes provide additional information about a topic.

Numbering: All numbers are decimal or hexadecimal unless otherwise indicated. In case of ambiguity, a subscript indicates the radix of nondecimal numbers. For example, 19 is a decimal number, but 19_{16} and 19A are hexadecimal numbers.

Extents: Extents are specified by a single number or a pair of numbers in brackets ([]) separated by a colon (:), and are inclusive. For example, bits [7:3] specify an extent including bits 7, 6, 5, 4, and 3. Multiple bit fields are shown as extents.

Register Figures: Register figures have bit and field position numbering starting at the right (low-order) and increasing to the left (high-order).

Signal Names: All signal names are printed in **boldface** type. Signal names that originate in an industry-standard specification, such as PCI or IDE, are printed in the case as found in the specification (usually uppercase). Active low signals have either a pound sign “#” appended, or a “not” overscore bar; for example, **DEVSEL#** and **RESET**.

Italic Type: *Italic* type emphasizes important information and indicates complete titles of documents.

Manual Conventions and Terminology

Terms: The following terms are used in this manual:

This term...	Refers to...
Microsoft Windows NT installation guide	The Microsoft <i>Windows NT Workstation Installation Guide</i> and the <i>Windows NT Server Installation Guide</i>
Windows NT	The Microsoft Windows NT Workstation and Windows NT Server operating systems

Features of the AlphaPC 164SX Motherboard

Table 2–1 provides an overview of the AlphaPC 164SX motherboard’s features.

Table 2–1 AlphaPC 164SX Features

Feature	Description
Microprocessor	Alpha 21164PC microprocessor (64-bit RISC)
Core logic chip	21174 core logic chip, comprising a single control chip that provides an interface to system memory and the PCI bus
Synchronous DRAM (SDRAM) memory	32MB to 512MB memory array -- Two banks of 128-bit memory; 168-pin unbuffered SDRAM DIMMs.
Caching	
L1 Icache	16KB, direct-mapped, instruction cache on the CPU chip
L1 Dcache	8KB, direct-mapped, data cache on the CPU chip
L2 backup cache	Onboard 1MB, direct-mapped, synchronous SSRAM backup cache with 128-bit data path
I/O and miscellaneous support	<ul style="list-style-type: none"> • 32-bit and 64-bit, 33-MHz PCI • Two 64-bit and two 32-bit PCI expansion slots • Cypress CY82C693U–NC chip with a PCI-to-ISA bridge, PCI EIDE, keyboard, mouse, and time-of-year clock • Two dedicated ISA expansion slots • SMC FDC37C669 combination controller chip provides control for diskettes, two UARTs with modem control, and parallel port • 1MB flash ROM
Firmware	Windows NT AlphaBIOS firmware

Figure 2–1 shows the AlphaPC 164SX motherboard and its components, and Table 2–2 describes these components.

Figure 2–1 AlphaPC 164SX Switch/Connector/Component Location

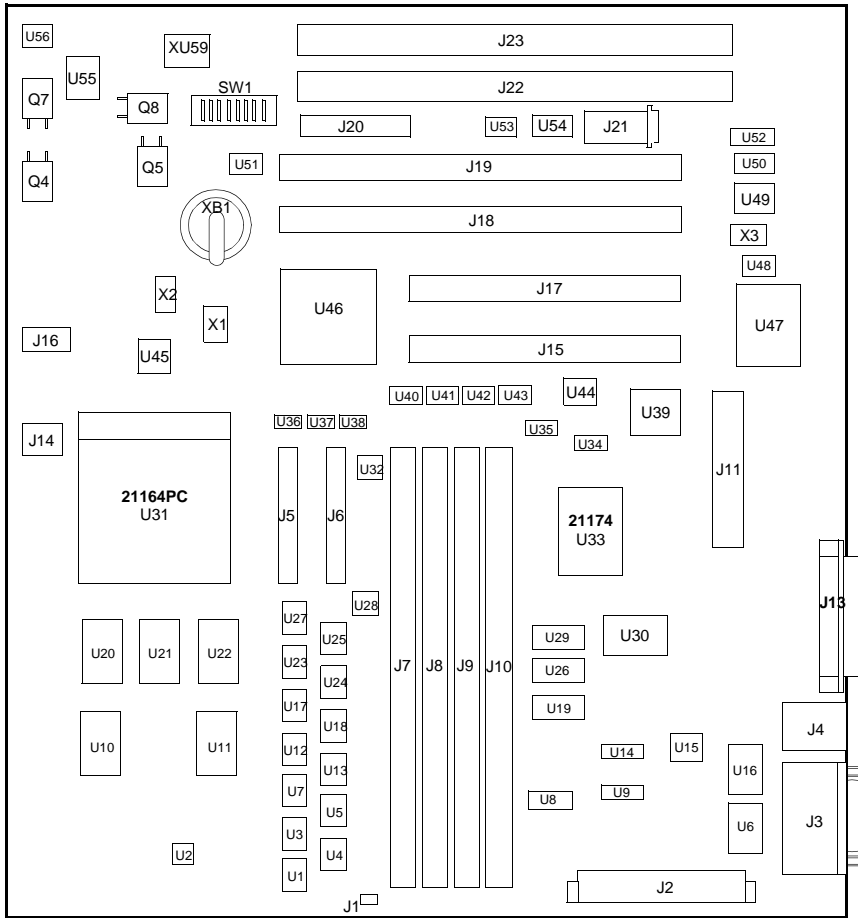

Table 2–2 AlphaPC 164SX Switch/Connector/Component List

Item No.	Description	Item No.	Description
XB1	RTC battery (CR2032)	J20	LEDs/speaker/buttons connectors
J1	Soft power connector	J21	SRAM test port connector
J2	Input power (+3 V, +5 V, -5 V, +12 V, -12 V)	J22	ISA slot 1
J3	COM1/COM2 (DB9) connectors	J23	ISA slot 0
J4	Keyboard/mouse connectors	SW1	Configuration switchpack
J5	EIDE drive 2/3 connector	U48	System clock PLL (CY2081)
J6	EIDE drive 0/1 connector	U10, U11, U20, U22	L2 cache data SRAMs
J7	SDRAM DIMM 0 [0:63] connector	U21	L2 cache tag SRAM
J8	SDRAM DIMM 1 [64:128] connector	U33	21174 core logic chip
J9	SDRAM DIMM 2 [0:63] connector	U19, U26, U29	Memory address/control buffers
J10	SDRAM DIMM 3 [64:128] connector	U1, U3, U4, U5, U7, U12, U13, U17, U18, U23, U24, U25, U27	Data switches
J11	Diskette (floppy) drive connector	U40 to U43	Interrupt shift registers
J13	Parallel I/O connector	U30	Flash ROM (1MB)
J14	Microprocessor fan/fan sense connector	U46	PCI-ISA Bridge (CY82C693U-NC)
J15	PCI slot 3 (32-bit)	U36 to U38	IDE buffers
J16	Fan power, enclosure (+12 V)	U47	Combination controller (FDC37C669)
J17	PCI slot 2 (32-bit)	U2, U28, U32	Reg-reg cache isolate logic
J18	PCI slot 1 (64-bit)	U31	Microprocessor, socketed (Alpha 21164PC)
J19	PCI slot 0 (64-bit)	U45	Microprocessor clock synthesizer (MC12439)

Power Requirements

2.1 Power Requirements

The AlphaPC 164SX motherboard has a total power dissipation of 90 W, excluding any plug-in PCI and ISA devices. Table 2–3 lists the power requirement for each dc supply voltage.

The power supply must be ATX-compliant.

Table 2–3 Power Supply DC Current Requirements

Voltage/Tolerance	Current ¹
+3.3 V dc, ±5%	5.0 A
+5 V dc, ±5%	12.0 A
–5 V dc, ±5%	0.0 A
+12 V dc, ±5%	1.0 A
–12 V dc, ±5%	100.0 mA

¹ Values indicated are for an AlphaPC 164SX motherboard with an Alpha 21164PC microprocessor operating at 400 MHz, with 128MB SDRAM, excluding adapter cards and disk drives.

Caution: **Fan sensor required.** The 21164PC microprocessor cooling fan *must* drive an RPM indicator signal. If the airflow stops, the sensor on the motherboard detects that the RPM has stopped, and resets the system.

2.2 Environmental Requirements

The 21164PC microprocessor is cooled by a small fan blowing directly into the chip’s heat sink. The AlphaPC 164SX motherboard is designed to run efficiently by using only this fan. Additional fans may be necessary depending upon cabinetry and the requirements of plug-in cards.

The AlphaPC 164SX motherboard is specified to run within the environment listed in Table 2–4.

Table 2–4 AlphaPC 164SX Motherboard Environmental Requirements

Parameter	Specification
Operating temperature	10°C to 40°C (50°F to 104°F)
Storage temperature	–55°C to 125°C (–67°F to 257°F)
Relative humidity	10% to 90% with maximum wet bulb temperature 28°C (82°F) and minimum dew point 2°C (36°F)
Rate of (dry bulb) temperature change	11°C/hour \pm 2°C/hour (20°F/hour \pm 4°F/hour)

2.3 Physical Parameters

The AlphaPC 164SX motherboard is an ATX-size printed-wiring board (PWB) with the following dimensions:

- Length: 30.48 cm (12.0 in \pm 0.0005 in)
- Width: 24.38 cm (9.6 in \pm 0.0005 in)
- Height: 6.00 cm (2.4 in)

Physical Parameters

2.3.1 ATX Hole Specification

Figure 2-2 shows the ATX hole specification for the AlphaPC 164SX.

Figure 2-2 ATX Hole Specification

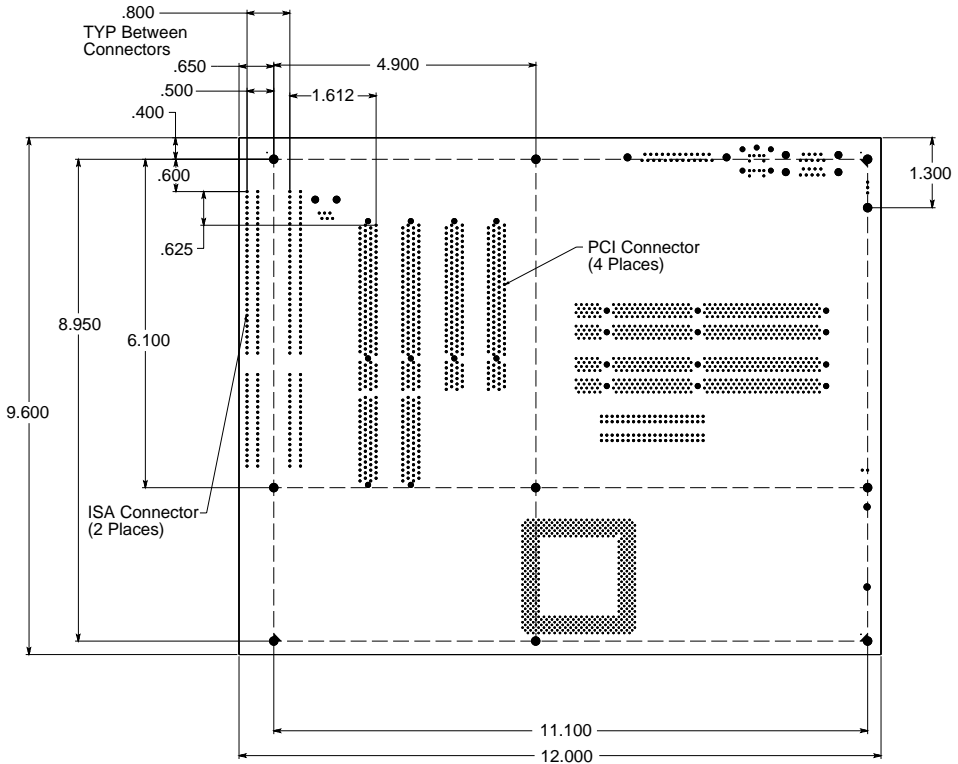

FM-06122.A14

2.3.2 ATX I/O Shield Requirements

Figure 2-3 shows the ATX I/O shield dimensions for the AlphaPC 164SX.

Figure 2-3 ATX I/O Shield Dimensions

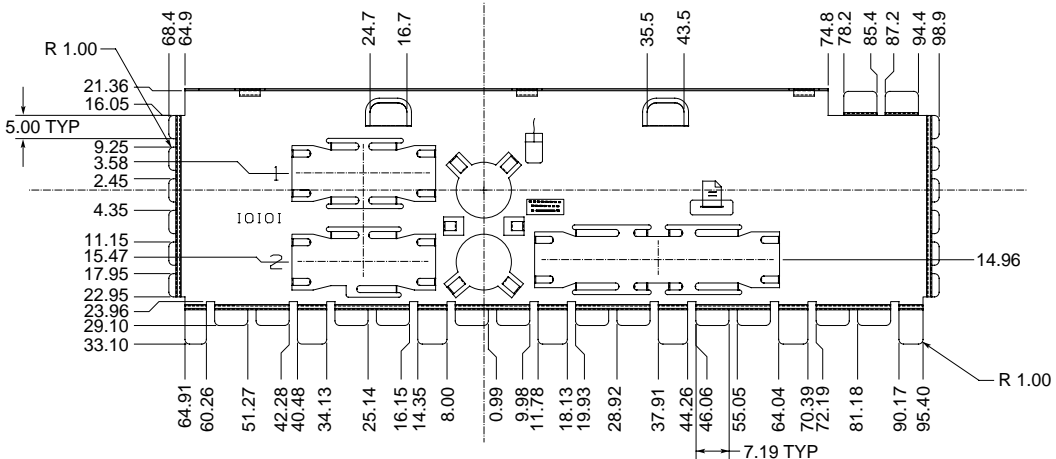

FM-05986.A14

AlphaPC 164SX Switch Configuration

The AlphaPC 164SX motherboard has a set of switches located at SW1, as shown in Figure 2–1. These switches set the hardware configuration. Figure 3–1 shows these switch configurations.

3.1 Password Bypass (CF2)

AlphaBIOS provides password protection. However, password bypass is provided for system setup or startup when the AlphaBIOS password is unavailable.

Password bypass is disabled by default, with switch CF2 of SW1 in the on position (see Figure 3–1). When this function is enabled, it disables the AlphaBIOS password verification and enables the user to set up or start up their system without the AlphaBIOS password. Password bypass also clears the password.

To disable this function and require a password, slide CF2 to the on position.

3.2 Mini-Debugger (CF3)

The Alpha SROM Mini-Debugger is stored in the flash ROM and is enabled/disabled by switch CF3. The default position for this switch is on (see Figure 3–1). When this switch is off, it causes the SROM initialization to trap to the Mini-Debugger after all initialization is complete, but before starting the execution of the system flash ROM code.

3.3 CPU Speed Selection (CF[6:4])

The clock synthesizer at U45 makes it possible to change the frequency of the microprocessor's clock output. The switch configuration is set in SW1, CF[6:4]. These three switches set the speed at power-up as listed in Figure 3–1. The microprocessor frequency divided by the ratio determines the system clock frequency.

Fail-Safe Booter (CF7)

3.4 Fail-Safe Booter (CF7)

The fail-safe booter provides an emergency recovery mechanism when the primary firmware image contained in flash memory has been corrupted. When flash memory has been corrupted, and no image can be loaded safely from the flash, you can run the fail-safe booter and boot another image from a diskette that is capable of reprogramming the flash.

Refer to Section 8.5 for more information.

Figure 3–1 AlphaPC 164SX Configuration Switches

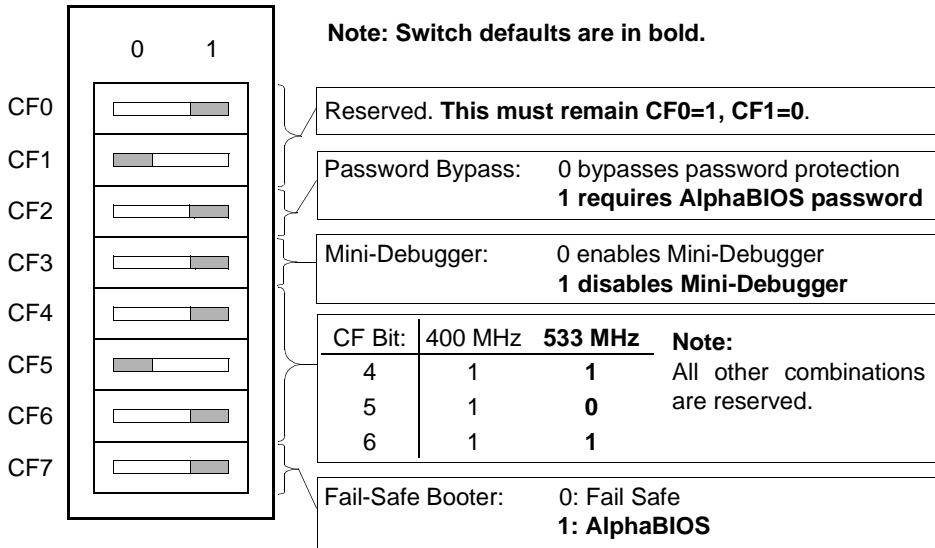

AlphaPC 164SX Connector Pinouts

This chapter lists the pinouts of the AlphaPC 164SX connectors (see Table 4–1 through Table 4–14). See Figure 2–1 for connector locations.

4.1 PCI Bus Connector Pinouts

Table 4–1 shows the PCI bus connector pinouts.

Table 4–1 PCI Bus Connector Pinouts

(Sheet 1 of 2)

Pin	Signal	Pin	Signal	Pin	Signal	Pin	Signal
32-Bit and 64-Bit PCI Connectors (J15, J17, J18, J19)							
A1	TRST#	A2	+12V	A3	TMS	A4	TDI
A5	Vdd	A6	INTA	A7	INTC	A8	Vdd
A9	—	A10	Vdd	A11	—	A12	Gnd
A13	Gnd	A14	—	A15	RST#	A16	Vdd
A17	GNT#	A18	Gnd	A19	—	A20	AD[30]
A21	+3V	A22	AD[28]	A23	AD[26]	A24	Gnd
A25	AD[24]	A26	IDSEL	A27	+3V	A28	AD[22]
A29	AD[20]	A30	Gnd	A31	AD[18]	A32	AD[16]
A33	+3V	A34	FRAME#	A35	Gnd	A36	TRDY#
A37	STOP#	A38	STOP#	A39	+3V	A40	SDONE
A41	SBO#	A42	Gnd	A43	PAR	A44	AD[15]
A45	+3V	A46	AD[13]	A47	AD[11]	A48	Gnd
A49	AD[09]	A50	Not used	A51	Not used	A52	C/BE#[0]
A53	+3V	A54	AD[06]	A55	AD[04]	A56	Gnd
A57	AD[02]	A58	AD[00]	A59	Vdd	A60	REQ64#
A61	Vdd	A62	Vdd	B1	-12V	B2	TCK
B3	Gnd	B4	TDO	B5	Vdd	B6	Vdd
B7	INTB	B8	INTD	B9	PRSENT1#	B10	—

PCI Bus Connector Pinouts

Table 4–1 PCI Bus Connector Pinouts

(Sheet 2 of 2)

Pin	Signal	Pin	Signal	Pin	Signal	Pin	Signal
B11	PRSENT2#	B12	Gnd	B13	Gnd	B14	—
B15	Gnd	B16	CLK	B17	Gnd	B18	REQ#
B19	Vdd	B20	AD[31]	B21	AD[29]	B22	Gnd
B23	AD[27]	B24	AD[25]	B25	+3V	B26	C/BE#[3]
B27	AD[23]	B28	Gnd	B29	AD[21]	B30	AD[19]
B31	+3V	B32	AD[17]	B33	C/BE#[2]	B34	Gnd
B35	IRDY#	B36	+3V	B37	DEVSEL#	B38	Gnd
B39	LOCK#	B40	PERR#	B41	+3V	B42	SERR#
B43	+3V	B44	C/BE#[1]	B45	AD[14]	B46	Gnd
B47	AD[12]	B48	AD[10]	B49	Gnd	B50	Not used
B51	Not used	B52	AD[08]	B53	AD[07]	B54	+3V
B55	AD[05]	B56	AD[03]	B57	Gnd	B58	AD[01]
B59	Vdd	B60	ACK64#	B61	Vdd	B62	Vdd
64-Bit PCI Connectors Only (J18, J19)							
A63	Gnd	A64	C/BE#[7]	A65	C/BE#[5]	A66	Vdd
A67	PAR64	A68	D[62]	A69	Gnd	A70	D[60]
A71	D[58]	A72	Gnd	A73	D[56]	A74	D[54]
A75	Vdd	A76	D[52]	A77	D[50]	A78	Gnd
A79	D[48]	A80	D[46]	A81	Gnd	A82	D[44]
A83	D[42]	A84	Vdd	A85	D[40]	A86	D[38]
A87	Gnd	A88	D[36]	A89	D[34]	A90	Gnd
A91	D[32]	A92	—	A93	Gnd	A94	—
B63	—	B64	Gnd	B65	C/BE#[6]	B66	C/BE#[4]
B67	Gnd	B68	D[63]	B69	D[61]	B70	Vdd
B71	D[59]	B72	D[57]	B73	Gnd	B74	D[55]
B75	D[53]	B76	Gnd	B77	D[51]	B78	D[49]
B79	Vdd	B80	D[47]	B81	D[45]	B82	Gnd
B83	D[43]	B84	D[41]	B85	Gnd	B86	D[39]
B87	D[37]	B88	Vdd	B89	D[35]	B90	D[33]
B91	Gnd	B92	—	B93	—	B94	Gnd

4.2 ISA Expansion Bus Connector Pinouts

Table 4–2 shows the ISA expansion bus connector pinouts.

Table 4–2 ISA Expansion Bus Connector Pinouts (J22, J23)

Pin	Signal	Pin	Signal	Pin	Signal	Pin	Signal
1	Gnd	2	IOCHCK#	3	RSTDRV	4	SD7
5	Vdd	6	SD6	7	IRQ9	8	SD5
9	–5V	10	SD4	11	DRQ2	12	SD3
13	–12V	14	SD2	15	ZEROWS#	16	SD1
17	+12V	18	SD0	19	Gnd	20	IOCHRDY
21	SMEMW#	22	AEN	23	SMEMR#	24	SA19
25	IOW#	26	SA18	27	IOR#	28	SA17
29	DACK3#	30	SA16	31	DRQ3	32	SA15
33	DACK1#	34	SA14	35	DRQ1	36	SA13
37	REFRESH#	38	SA12	39	SYSCLK	40	SA11
41	IRQ7	42	SA10	43	IRQ6	44	SA9
45	IRQ5	46	SA8	47	IRQ4	48	SA7
49	IRQ3	50	SA6	51	DACK2#	52	SA5
53	TC	54	SA4	55	BALE	56	SA3
57	Vdd	58	SA2	59	OSC	60	SA1
61	Gnd	62	SA0	63	MEMCS16#	64	SBHE#
65	IOCS16#	66	LA23	67	IRQ10	68	LA22
69	IRQ11	70	LA21	71	IRQ12	72	LA20
73	IRQ15	74	LA19	75	IRQ14	76	LA18
77	DACK0#	78	LA17	79	DRQ0	80	MEMR#
81	DACK5#	82	MEMW#	83	DRQ5	84	SD8
85	DACK6#	86	SD9	87	DRQ6	88	SD10
89	DACK7#	90	SD11	91	DRQ7	92	SD12
93	Vdd	94	SD13	95	MASTER#	96	SD14
97	Gnd	98	SD15	—	—	—	—

SDRAM DIMM Connector Pinouts

4.3 SDRAM DIMM Connector Pinouts

Table 4–3 shows the SDRAM DIMM connector pinouts.

Table 4–3 SDRAM DIMM Connector Pinouts (J7 through J10)¹

(Sheet 1 of 2)

Pin	Signal	Pin	Signal	Pin	Signal	Pin	Signal
1	Gnd	2	DQ0	3	DQ1	4	DQ2
5	DQ3	6	+3V	7	DQ4	8	DQ5
9	DQ6	10	DQ7	11	DQ8	12	Gnd
13	DQ9	14	DQ10	15	DQ11	16	DQ12
17	DQ13	18	+3V	19	DQ14	20	DQ15
21	CB0	22	CB1	23	Gnd	24	NC
25	NC	26	+3V	27	$\overline{\text{WE}}$	28	DQMB0
29	DQMB1	30	$\overline{\text{S0}}$	31	NC	32	Gnd
33	A0	34	A2	35	A4	36	A6
37	A8	38	A10	39	A12	40	+3V
41	+3V	42	CK0	43	Gnd	44	NC
45	$\overline{\text{S2}}$	46	DQMB2	47	DQMB3	48	NC
49	+3V	50	NC	51	NC	52	CB2
53	CB3	54	Gnd	55	DQ16	56	DQ17
57	DQ18	58	DQ19	59	+3V	60	DQ20
61	NC	62	NC	63	CKE1	64	Gnd
65	DQ21	66	DQ22	67	DQ23	68	Gnd
69	DQ24	70	DQ25	71	DQ26	72	DQ27
73	+3V	74	DQ28	75	DQ29	76	DQ30
77	DQ31	78	Gnd	79	CK2	80	NC
81	NC	82	SDA	83	SCL	84	+3V
85	Gnd	86	DQ32	87	DQ33	88	DQ34
89	DQ35	90	+3V	91	DQ36	92	DQ37
93	DQ38	94	DQ39	95	DQ40	96	Gnd
97	DQ41	98	DQ42	99	DQ43	100	DQ44
101	DQ45	102	+3V	103	DQ46	104	DQ47
105	CB4	106	CB5	107	Gnd	108	NC
109	NC	110	+3V	111	$\overline{\text{CAS}}$	112	DQMB4
113	DQMB5	114	S1	115	RAS	116	Gnd
117	A1	118	A3	119	A5	120	A7
121	A9	122	BA0	123	A13	124	+3V

EIDE Drive Bus Connector Pinouts

Table 4–3 SDRAM DIMM Connector Pinouts (J7 through J10)¹

(Sheet 2 of 2)

Pin	Signal	Pin	Signal	Pin	Signal	Pin	Signal
125	CK1	126	BA1²	127	Gnd	128	CKE0
129	S$\bar{3}$	130	DQMB6	131	DQMB7	132	PD³
133	+3V	134	NC	135	NC	136	CB6
137	CB7	138	Gnd	139	DQ48	140	DQ49
141	DQ50	142	DQ51	143	+3V	144	DQ52
145	NC	146	NC	147	PD	148	Gnd
149	DQ53	150	DQ54	151	DQ55	152	Gnd
153	DQ56	154	DQ57	155	DQ58	156	DQ59
157	+3V	158	DQ60	159	DQ61	160	DQ62
161	DQ63	162	Gnd	163	CK3	164	NC
165	SA0	166	SA1	167	SA2	168	+3V

¹ Pins 1 through 84 are on the front side and pins 85 through 168 are on the back side.

² The AlphaPC 164SX uses **BA1** as both **BA1** and **ADDR12**. Therefore, four-bank DIMMs using **ADDR[11:0]** are the maximum size. (Two-bank DIMMs can use **ADDR[12:0]**.)

³ Pull-down.

4.4 EIDE Drive Bus Connector Pinouts

Table 4–4 shows the EIDE drive bus connector pinouts.

Table 4–4 EIDE Drive Bus Connector Pinouts (J5, J6)

Pin	Signal	Pin	Signal	Pin	Signal	Pin	Signal
1	RESET	2	Gnd	3	IDE_D7	4	IDE_D8
5	IDE_D6	6	IDE_D9	7	IDE_D5	8	IDE_D10
9	IDE_D4	10	IDE_D11	11	IDE_D3	12	IDE_D12
13	IDE_D2	14	IDE_D13	15	IDE_D1	16	IDE_D14
17	IDE_D0	18	IDE_D15	19	Gnd	20	NC (key pin)
21	MARQ	22	Gnd	23	IOW	24	Gnd
25	IOR	26	Gnd	27	CHRDY	28	BALE
29	MACK	30	Gnd	31	IRQ	32	IOCS16
33	ADDR1	34	NC	35	ADDR0	36	ADDR2
37	CS0	38	CS1	39	ACT	40	Gnd

Diskette (Floppy) Drive Bus Connector Pinouts

4.5 Diskette (Floppy) Drive Bus Connector Pinouts

Table 4–5 shows the diskette (floppy) drive bus connector pinouts.

Table 4–5 Diskette (Floppy) Drive Bus Connector Pinouts (J11)

Pin	Signal	Pin	Signal	Pin	Signal	Pin	Signal
1	Gnd	2	DEN0	3	Gnd	4	NC
5	Gnd	6	DEN1	7	Gnd	8	INDEX
9	Gnd	10	MTR0	11	Gnd	12	DR1
13	Gnd	14	DR0	15	Gnd	16	MTR1
17	Gnd	18	DIR	19	Gnd	20	STEP
21	Gnd	22	WDATA	23	Gnd	24	WGATE
25	Gnd	26	TRK0	27	Gnd	28	WRTPRT
29	Gnd	30	RDATA	31	Gnd	32	HDSEL
33	Gnd	34	DSKCHG	—	—	—	—

4.6 Parallel Bus Connector Pinouts

Table 4–6 shows the parallel bus connector pinouts.

Table 4–6 Parallel Bus Connector Pinouts (J13)

Pin	Signal	Pin	Signal	Pin	Signal	Pin	Signal
1	STB	2	PD0	3	PD1	4	PD2
5	PD3	6	PD4	7	PD5	8	PD6
9	PD7	10	ACK	11	BUSY	12	PE
13	SLCT	14	AFD	15	ERR	16	INIT
17	SLIN	18	Gnd	19	Gnd	20	Gnd
21	Gnd	22	Gnd	23	Gnd	24	Gnd
25	Gnd	—	—	—	—	—	—

4.7 COM1/COM2 Serial Line Connector Pinouts

Table 4–7 shows the COM1/COM2 serial line connector pinouts.

Table 4–7 COM1/COM2 Serial Line Connector Pinouts (J3)

COM1 Pin (Top)	COM1 Signal	COM2 Pin (Bottom)	COM2 Signal
1	DCD1	1	DCD2
2	RxD1	2	RxD2
3	TxD1	3	TxD2
4	DTR1	4	DTR2
5	SG1	5	SG2
6	DSR1	6	DSR2
7	RTS1	7	RTS2
8	CTS1	8	CTS2
9	RI1	9	RI2

4.8 Keyboard/Mouse Connector Pinouts

Table 4–8 shows the keyboard/mouse connector pinouts.

Table 4–8 Keyboard/Mouse Connector Pinouts (J4)

Keyboard Pin (Top)	Keyboard Signal	Mouse Pin (Bottom)	Mouse Signal
1	KBDATA	1	MSDATA
2	NC	2	NC
3	Gnd	3	Gnd
4	Vdd	4	Vdd
5	KBCLK	5	MSCLK
6	NC	6	NC

SROM Test Data Input Connector Pinouts

4.9 SROM Test Data Input Connector Pinouts

Table 4–9 shows the SROM test data input connector pinouts.

Table 4–9 SROM Test Data Input Connector Pinouts (J21)

Pin	Signal	Description
1	NC	—
2	SROM_CLK_L	Clock out
3	Gnd	—
4	NC	—
5	TEST_SROM_D_L	SROM serial data in
6	NC	—

4.10 Input Power Connector Pinouts

Table 4–10 shows the input power connector pinouts.

Table 4–10 Input Power Connector Pinouts (J2)¹

Pin	Voltage	Pin	Voltage	Pin	Voltage	Pin	Voltage
1	+3.3 V dc	2	+3.3 V dc	3	Gnd	4	+5 V dc
5	Gnd	6	+5 V dc	7	Gnd	8	P_DCOK
9	5 V SB	10	+12 V dc	11	+3.3 V dc	12	–12 V dc
13	Gnd	14	PS_ON	15	Gnd	16	Gnd
17	Gnd	18	–5 V dc	19	+5 V dc	20	+5 V dc

¹ This pinout is ATX-compliant.

4.11 Enclosure Fan Power Connector Pinouts

Table 4–11 shows the enclosure fan power connector pinouts.

Table 4–11 Enclosure Fan (+12 V dc) Power Connector Pinouts (J16)

Pin	Voltage
1	Gnd
2	+12 V dc
3	Gnd

4.12 Microprocessor Fan Power Connector Pinouts

Table 4–12 shows the microprocessor fan power connector pinouts.

Table 4–12 Microprocessor Fan Power Connector Pinouts (J14)

Pin	Signal	Description
1	+12V	—
2	FAN_CONN_L	Fan connected
3	Gnd	—

4.13 Soft Power Connector Pinouts

Table 4–13 shows the soft power connector pinouts.

Table 4–13 Soft Power Connector Pinouts (J1)

Pin	Signal	Description
1	Input	System power on/off
2	Gnd	—

4.14 Multipurpose Connector Pinouts

J20 is a multipurpose connector that provides pins for the following functions:

- System speaker
- LEDs for power and the IDE drive
- Buttons for reset and halt

Table 4–14 shows the multipurpose connector pinouts, and Figure 4–1 shows the connector layout.

Table 4–14 Multipurpose Connector Pinouts (J20)

(Sheet 1 of 2)

Pin	Signal	Description
1	Gnd	—
2	HALT_BUTTON ¹	Halt system
3	Gnd	—
4	RESET_BUTTON	Reset system

Multipurpose Connector Pinouts

Table 4–14 Multipurpose Connector Pinouts (J20)

(Sheet 2 of 2)

Pin	Signal	Description
5	HD_PU	Hard drive power-up
6	HD_LED	Pull-up to Vdd
7	—	No connection
8	POWER_LED_L	Pull-up to Vdd
10, 12, 14, 16	Gnd	—
9	SPKR	Speaker output
15	Vdd	—
11, 13	—	No connection

¹ The halt button is not used with the Windows NT operating system.

Figure 4–1 Multipurpose Connector Pinouts

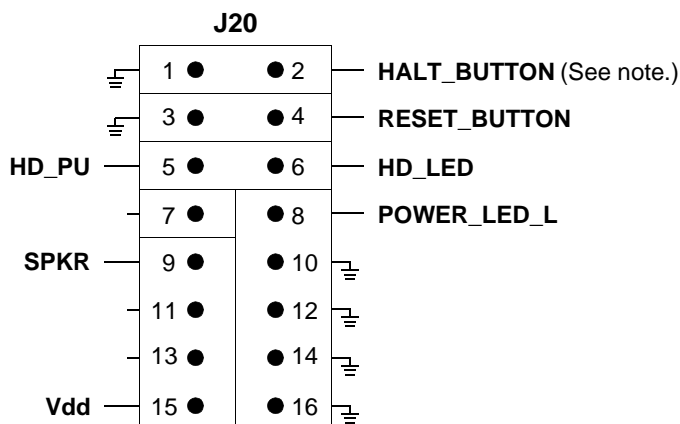

Note: The halt button is not used with Windows NT.

Memory and Microprocessor Configuration

For higher system speed or greater throughput, SDRAM memory can be upgraded by replacing DIMMs with those of greater size.

When configuring or upgrading SDRAM, observe the following rules:

- Each DIMM must be a 168-bit unbuffered version and have a frequency of 100 MHz.
- Each bank consists of two DIMMs and must be fully populated.
- Both DIMMs in the same bank must be of equal size.

5.1 Configuring SDRAM Memory

Although not an exhaustive list, Table 5–1 lists the tested SDRAM memory configurations available. As additional configurations become available, they will be posted in online revisions of this manual on the Alpha OEM home page. See Appendix A for the URL.

For a list of vendors who supply components and accessories for the AlphaPC 164SX, see Appendix A.

Refer to Figure 2–1 for DIMM connector locations.

Note: 1Mb × 72 DIMMs are not supported.

Upgrading SDRAM Memory

Table 5–1 AlphaPC 164SX SDRAM Memory Configurations

Total Memory	Bank 0 ¹		Bank 1 ¹	
	J7	J8	J9	J10
32MB	2Mb × 72	2Mb × 72	—	—
64MB	2Mb × 72	2Mb × 72	2Mb × 72	2Mb × 72
	4Mb × 72	4Mb × 72	—	—
96MB	4Mb × 72	4Mb × 72	2Mb × 72	2Mb × 72
128MB	4Mb × 72	4Mb × 72	4Mb × 72	4Mb × 72
	8Mb × 72	8Mb × 72	—	—
160MB	8Mb × 72	8Mb × 72	2Mb × 72	2Mb × 72
192MB	8Mb × 72	8Mb × 72	4Mb × 72	4Mb × 72
256MB	8Mb × 72	8Mb × 72	8Mb × 72	8Mb × 72
	16Mb × 72	16Mb × 72	—	—
512MB	16Mb × 72	16Mb × 72	16Mb × 72	16Mb × 72

¹ 64-bit-wide DIMMs can also be used.

5.2 Upgrading SDRAM Memory

You can upgrade memory in the AlphaPC 164SX by adding more DIMMs or replacing the ones you have with a greater size. Refer to Figure 2–1 for DIMM connector locations.

Use the following general guidelines:

1. *Observe antistatic precautions.* Handle DIMMs only at the edges to prevent damage.
2. Remove power from the system.

3. Align the DIMM so that the notch in the DIMM matches the key in the socket.
4. Firmly push the DIMM straight into the connector. Ensure that the DIMM snaps into the plastic locking levers on both ends.
5. Restore power to the system.

5.3 Increasing Microprocessor Speed

This section describes how to complete the following actions to increase microprocessor speed:

- Replace the Alpha 21164PC microprocessor with an Alpha chip that has a higher speed rating.
- Reconfigure the clock divisor switches.

5.3.1 Preparatory Information

Caution: Static-Sensitive Component – Due to the sensitive nature of electronic components to static electricity, anyone handling the microprocessor *must* wear a properly grounded antistatic wriststrap. Use of antistatic mats, ESD approved workstations, or exercising other good ESD practices is recommended.

An Alpha 21164PC microprocessor with a higher speed rating is available from your sales office. See Appendix A for information about supporting products.

When replacing the microprocessor chip, also replace the thermal conducting GRAFOIL pad. See Appendix A for information about the parts kit, which includes the heat sink, GRAFOIL pad, two hex nuts, heat-sink clips, 52-mm fan, and four screws.

5.3.2 Required Tools

The following tools are required when replacing the microprocessor chip:

A TS30 manual nut/torque driver (or equivalent) with the following attachments is required to affix the heat sink and fan to the microprocessor's IPGA package:

- 1/4-inch hex bit
- 3/8-inch socket with 1/4-inch hex drive
- #2 Phillips-head screwdriver bit

Increasing Microprocessor Speed

5.3.3 Removing the 21164PC Microprocessor

Remove the microprocessor currently in place at location U31 by performing the following steps:

1. Unplug the fan power/sensor cable from connector J14 (see Figure 2–1).
2. Remove the four 6–32 × 0.625-inch screws that secure the fan to the heat sink.
3. Remove the fan.
4. If the sink/chip/fan clip is used, remove it by unhooking its ends from around the ZIF socket retainers.
5. Using a 3/8-inch socket, remove the two nuts securing the heat sink to the microprocessor studs.
6. Remove the heat sink by gently lifting it off the microprocessor.
7. Remove and discard the GRAFOIL heat conduction pad.
8. Thoroughly clean the bottom surface of the heat sink before affixing it to the new microprocessor.
9. Lift the ZIF socket actuator handle to a full 90° angle.
10. Remove the microprocessor chip by lifting it straight out of the socket.

5.3.4 Installing the 21164PC Microprocessor

Install the new microprocessor in location U31 by performing the following steps:

Note: Install the heat sink only after the microprocessor has been assembled to the ZIF socket.

1. Observe antistatic precautions.
2. Lift the ZIF socket actuator handle to a full 90° angle.
3. Ensure that all the pins on the microprocessor package are straight.
4. The ZIF socket and microprocessor are keyed to allow for proper installation. Align the microprocessor, with its missing AD01 pin, with the corresponding plugged AD01 position on the ZIF socket. Gently lower into position.
5. Close the ZIF socket actuator handle to its locked position.
6. Install the heat sink and heat-sink fan as directed in the following steps. A heat-sink/fan kit is available from the vendor listed in Appendix A. Refer to Figure 5–1 for heat-sink and fan assembly details.

Figure 5-1 Fan/Heat-Sink Assembly

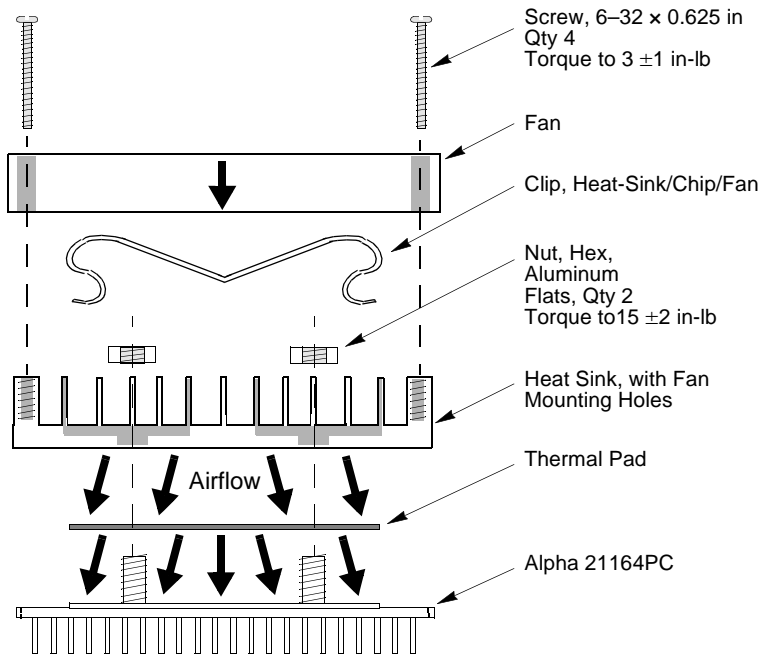

- a. Put the GRAFOIL thermal pad in place. The GRAFOIL pad is used to improve the thermal conductivity between the chip package and the heat sink by replacing micro air pockets with a less insulative material. Perform the following steps to position the GRAFOIL pad:
 1. Perform a visual inspection of the package slug to ensure that it is free of contamination.
 2. Wearing clean gloves, pick up the GRAFOIL pad. *Do not* perform this with bare hands because skin oils can be transferred to the pad.
 3. Place the GRAFOIL pad on the gold-plated slug surface and align it with the threaded studs.

Increasing Microprocessor Speed

- b. Attach the microprocessor heat sink. The heat-sink material is clear anodized, hot-water-sealed, 6061-T6 aluminum. The nut material is 2011-T3 aluminum (this grade is critical). Perform the following steps to attach the heat sink:
 1. Observe antistatic precautions.
 2. Align the heat-sink holes with the threaded studs on the ceramic package.
 3. Handle the heat sink by the edges and lower it onto the chip package, taking care not to damage the stud threads.
 4. Set a calibrated torque driver to 15 in-lb, ± 2 in-lb, (2.3 Nm, ± 0.2 Nm). The torque driver should have a mounted 3/8-inch socket.
 5. Insert a nut into the 3/8-inch socket, place on one of the studs, and tighten to the specified torque. Repeat for the second nut.
 6. If the sink/chip/fan clip is used, properly install it by positioning it over the assembly and hooking its ends around the ZIF socket retainers.
- c. Attach the heat-sink fan assembly:
 1. Place the fan assembly on top of the heat sink, aligning the fan mounting holes with the corresponding threaded heat-sink holes. Align the fan so that the fan power/sensor wires exit the fan closest to connector J14 (see Figure 2–1). Fan airflow must be directed into the heat sink (fan label facing down toward the heat sink).
 2. Using a calibrated torque driver set to 3 in-lb, ± 1 in-lb, secure the fan to the heat sink with four 6–32 \times 0.625-inch screws.
 3. Plug the fan power/sensor cable into connector J14.

Note: When installing the microprocessor, you must change the frequency of its clock output by setting the system clock divisor switches, as described in Section 3.3.

6

Interrupts and ISA Bus Addresses

This section lists the system and I/O interrupt assignments. It also lists the physical AlphaPC 164SX I/O space assignments.

6.1 Interrupts

Table 6–1 lists each AlphaPC 164SX ISA interrupt and its source.

Table 6–1 ISA Interrupts

(Sheet 1 of 2)

Interrupt Number	Interrupt Source
IRQ0	Internal timer 1
IRQ1	Keyboard
IRQ2	Interrupt from controller 2
IRQ3	COM2
IRQ4	COM1
IRQ5	Available
IRQ6	Diskette (floppy)
IRQ7	Parallel port
IRQ8# ¹	Reserved
IRQ9	Available
IRQ10	Available
IRQ11	Available
IRQ12	Mouse

ISA I/O Address Map

Table 6–1 ISA Interrupts

(Sheet 2 of 2)

Interrupt Number	Interrupt Source
IRQ13	Available
IRQ14	IDE
IRQ15	IDE

¹ The # symbol indicates an active low signal.

6.2 ISA I/O Address Map

Table 6–2 lists the AlphaPC 164SX ISA I/O space address mapping.

Table 6–2 ISA I/O Address Map

Range (hex)	Usage
000-00F	8237 DMA #1
020-021	8259 PIC #1
040-043	8253 timer
060-061	Ubus IRQ12 and NMI control
070	CMOS RAM address and NMI mask register
080-08F	DMA page registers
0A0-0A1	8259 PIC #2
0C0-0DF	8237 DMA #2
2F8-2FF	Serial port—COM2
370-377	Secondary diskette (floppy)
3BC-3BF	Parallel port—LPT1
3F0-3F7	Primary diskette (floppy)
3F8-3FF	Serial port—COM1

Configuring for Windows NT

This chapter contains a subset of the online documentation necessary to start up your system. You can access the complete documentation online when your system is up and running.

The online documentation describes configuration information for Alpha systems running AlphaBIOS. The online documentation resides on a diskette labeled *AlphaPC 164SX AlphaBIOS Firmware* diskette. The documentation is available as a text file and a Help file compatible with Windows NT 4.0 and Windows 95.

7.1 AlphaBIOS

The AlphaPC 164SX motherboard ships with AlphaBIOS firmware and online documentation that describes how to configure the firmware for Windows NT. This firmware initializes the system and enables you to install and boot the Windows NT operating system. The AlphaBIOS firmware resides in the flash ROM on the AlphaPC 164SX motherboard.

AlphaBIOS

7.1.1 AlphaBIOS Conventions

AlphaBIOS uses universally accepted keys and key combinations for navigating the interface and selecting items. If you are familiar with MS-DOS or Microsoft Windows keyboard conventions, navigating AlphaBIOS is simple. Table 7–1 shows the keys to use for navigating and selecting items in AlphaBIOS.

Table 7–1 Action Keys

Press...	To...
TAB	Move highlight forward between fields of a dialog.
SHIFT + TAB	Move highlight backwards between fields of a dialog.
↑ or ↓	Move highlight within a menu, or cycle through available field values in a dialog window.
ALT + ↓	Drop down a menu of choices from a drop-down listbox. A drop-down listbox can be recognized by the symbol ↓.
HOME	Move to the beginning of a text entry field.
END	Move to the end of a text entry field.
← →	Move to the left or right in a text entry field.
ESC	Discard changes and back up to previous screen.

Two levels of keyboard help are available:

- Press **F1** once to display explanations of the keystrokes available for the *currently displayed* part of AlphaBIOS.
- Press **F1** twice to display explanations of the keystrokes available for navigating *throughout* AlphaBIOS.

7.1.2 Starting the AlphaBIOS Setup Program

When you power up or reset your system, the boot screen with the system logo is displayed. Pressing **F2** at this screen starts the setup program. Figure 7–1 shows an example of an AlphaBIOS Boot Screen with the “Press <F2> to enter SETUP” message at the bottom.

Figure 7-1 AlphaBIOS Boot Screen

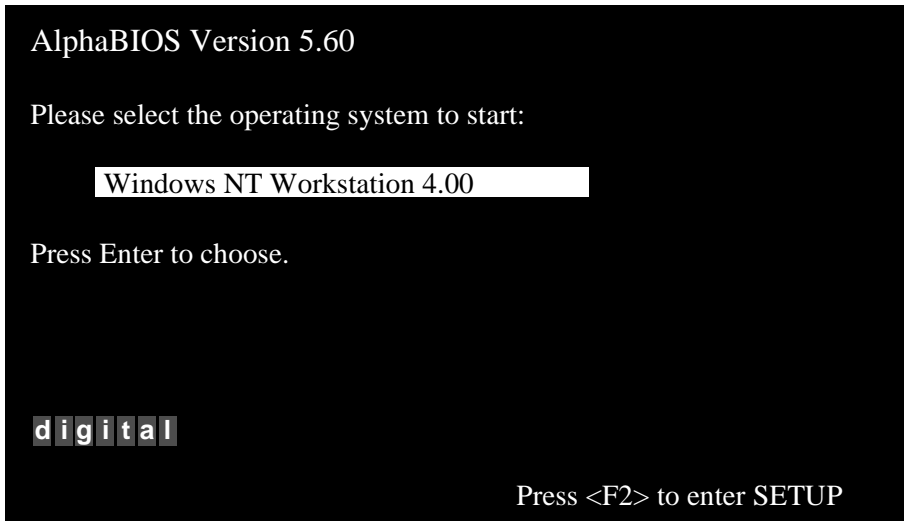

7.1.3 Upgrading AlphaBIOS

As new versions of Windows NT are released, it might be necessary to upgrade AlphaBIOS to the latest version. Additionally, as improvements are made to AlphaBIOS, it might be desirable to upgrade to take advantage of new features.

To upgrade from an earlier version of AlphaBIOS:

1. Insert the diskette or CD-ROM containing the AlphaBIOS upgrade.
2. Run the AlphaBIOS Setup program by restarting your system and pressing **F2** when the boot screen is displayed.
3. In the main AlphaBIOS Setup screen, select Upgrade AlphaBIOS and press **Enter**.

This menu option is used to upgrade to later versions of AlphaBIOS. When you choose this option, the existing AlphaBIOS searches for an executable AlphaBIOS update file; first on CD-ROM, then on diskette. Once the update file has been found, AlphaBIOS executes it, and the firmware is upgraded.

4. After the upgrade is complete, the system either resets automatically or prompts you to reset the system.

AlphaBIOS

7.1.4 Performing CMOS Setup Tasks

CMOS Setup is divided into two modes, standard and advanced. Table 7–2 lists the tasks that you can perform in standard and advanced setup mode.

Table 7–2 CMOS Setup Tasks

Standard CMOS Setup	Advanced CMOS Setup
Autostart	Memory test
Date and time	PCI parity
Floppy	Password protection
Keyboard	SCSI termination SCSI BIOS emulation

To enter standard CMOS Setup:

- Start AlphaBIOS Setup, select CMOS Setup, and press **Enter**.

To enter advanced CMOS Setup:

1. Start AlphaBIOS Setup, select CMOS Setup, and press **Enter**.
2. In the CMOS Setup screen, press **F6**.

7.1.5 Setting Up Your Hard Disk

Express hard-disk setup is an easy way to create the recommended partition arrangement on your first hard disk, disk 0. Note, however, that express hard-disk setup does not format the large partition with NTFS. You will have the opportunity to do this during the Windows NT installation.

Note: AlphaBIOS assigns “disk 0” to the hard disk with the lowest SCSI ID number on the first bus in your system. If no SCSI devices are present, AlphaBIOS assigns disk 0 to the first IDE hard drive.

Caution: If you have any information on your disk that you want to save, be sure to back it up before using express hard-disk setup.

To perform express hard-disk setup:

1. Start AlphaBIOS Setup, select Hard Disk Setup, and press **Enter**.
2. Press **F7** to enter express hard-disk setup.
3. Press **F10** to continue with the setup.

For information on manually managing hard disks, see the online documentation.

7.1.6 Displaying Your System Configuration

You can use AlphaBIOS to display your system configuration in a clear, easy-to-read format, organized by categories: system board, memory, hard disk, PCI, SCSI, and peripherals.

To display your system configuration:

1. Start AlphaBIOS Setup, select Display System Configuration, and press **Enter**.
2. In the Display System Configuration screen, use the arrow keys to select the configuration category that you want to see, such as the example shown in Figure 7-2.

AlphaBIOS

Figure 7-2 Display System Configuration

Display System Configuration

Systemboard Configuration
Hard Disk Configuration
PCI Configuration
SCSI Configuration
ISA Configuration
Memory Configuration
Integrated Peripherals

System Type: AlphaPC 164SX

Processor: Alpha 21164PC, Revision 1
Speed: 533 MHz
Cache: 1 MB
Memory: 128 MB

Floppy Drive A: 3.5" 1.44 MB
Floppy Drive B: None
Keyboard: U.S. 101-keyboard

AlphaBIOS Version: 5.60

ESC=Exit

Use the Arrow or Tab keys to view different categories of configuration information.

7.1.7 Running a Maintenance Program

You can run maintenance programs such as RAID and other configuration utilities directly from the AlphaBIOS utility menu.

To run a maintenance program:

1. Start AlphaBIOS Setup, select Utilities, select Run Maintenance Program from the submenu shown in Figure 7–3, and press **Enter**.

Figure 7–3 Run Maintenance Program Submenu

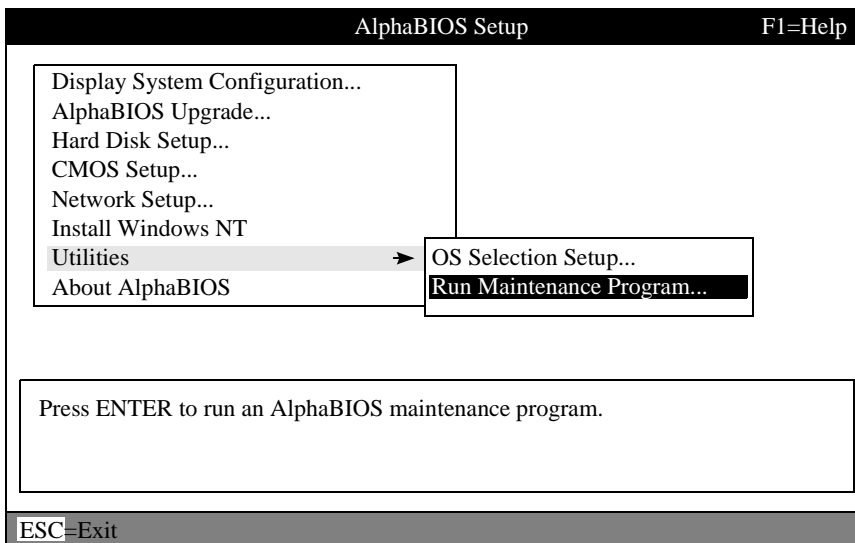

2. In the Run Maintenance Program dialog box, type the name of the program to be run at the Program Name prompt, as shown in Figure 7–4. Then tab to the Location list box and select the hard-disk partition, floppy diskette, or CD-ROM drive from which to run the program.
3. Press **Enter** to execute the program.

Installing the Windows NT Operating System

Figure 7-4 Entering the Program Name

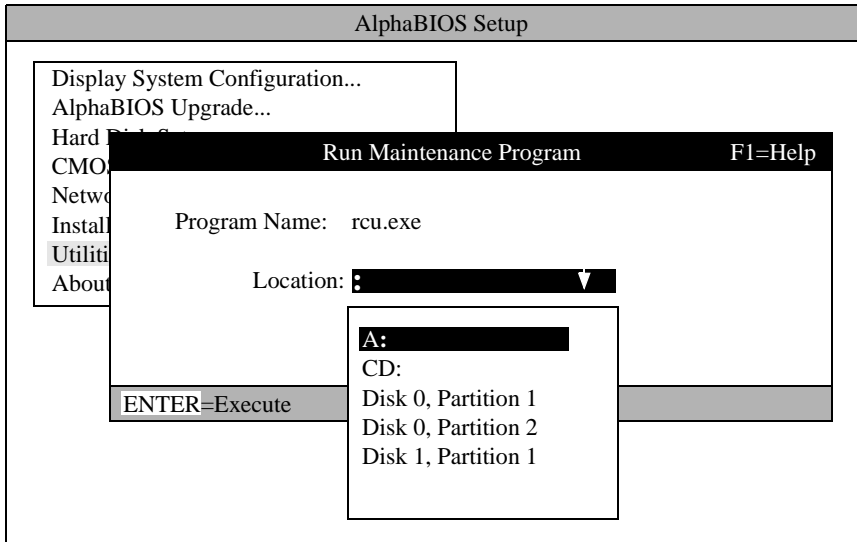

If you are running a utility from a floppy diskette, you can simply type the utility's name into the Program Name field, and press **Enter**. This is because the floppy drive is the default selection in the Current Partition field.

Use Alt + ↓ when a list box is selected to open the list.

7.2 Installing the Windows NT Operating System

This section supplements the Microsoft Windows NT installation guide for installing the Windows NT operating system on an AlphaPC 164SX system.

If you already have a previous version of Windows NT installed, see the Microsoft Windows NT installation guide for information about how to upgrade to a new version of the operating system.

Installing the Windows NT Operating System

7.2.1 Requirements

You need the following hardware and software to install the Windows NT operating system on an AlphaPC 164SX system:

- A 100MB or larger drive

Note: For information regarding supported IDE/ATA hard drives, ATAPI CD-ROM drives, SCSI hard drives, CD-ROM drives, and controllers supported as boot/installation devices, see the README.TXT file on the *AlphaPC 164SX AlphaBIOS Firmware* diskette.

- 32MB or more of memory
- The Microsoft Windows NT compact disk
- The *AlphaPC 164SX AlphaBIOS Firmware* diskette
- The *AlphaPC 164SX Windows NT 4.0 Installation* diskette

Note: The *AlphaPC 164SX Windows NT 4.0 Installation* diskette is required for the Windows NT 4.0 operating system. Future versions of Windows NT may not require this diskette. Contact your OEM or system vendor for details.

7.2.2 Before Installing Windows NT

Before installing Windows NT, ensure that you have completed the following tasks:

- Use the CMOS Setup program to:
 - Set the system date and time
 - Verify that all other standard CMOS settings match your system.

Refer to Section 7.1.4 for more information about the CMOS Setup program.

- Perform an express hard-disk setup. This configures the first hard disk that AlphaBIOS detects in your system with the recommended default partition arrangement. See Section 7.1.5 for more information on setting up your hard disk. If you do not want to use the express hard-disk setup, refer to the online AlphaBIOS documentation for other hard-disk setup options.

Installing the Windows NT Operating System

7.2.3 Starting Windows NT Setup

Windows NT Setup, located on the Microsoft Windows NT compact disc, installs the Windows NT operating system. Windows NT Setup provides a brief description of the available key functions at the bottom of the screen.

During the Windows NT installation procedure, you may be prompted for the type of computer that you have. For the AlphaPC 164SX system, choose AlphaPC 164SX. If AlphaPC 164SX is not one of the choices, choose “other” *after* you have inserted the *AlphaPC 164SX Windows NT 4.0 Installation* diskette. The following procedure supersedes the Starting Setup on a RISC-based Computer section of the Microsoft Windows NT installation guide.

To start the Windows NT Setup program:

1. Insert the Windows NT compact disc in the CD-ROM drive.
2. Restart your computer.
3. Start AlphaBIOS Setup, select Install Windows NT, and press **Enter**.
4. Follow the instructions on the screen.

This chapter contains information about troubleshooting hardware and software during AlphaPC 164SX startup.

8.1 Password Bypass

AlphaBIOS provides password protection. However, password bypass is provided for system setup or startup when the AlphaBIOS password is unavailable.

Password bypass is enabled by sliding switch CF2 in the SW1 switchpack to the off position (see Figure 3–1). This disables the AlphaBIOS password verification and enables the user to set up or start up their system without the AlphaBIOS password. Password bypass also clears the password.

8.2 Hardware Startup

Use the following troubleshooting steps if video is not working on your system. If you still have no video after reviewing these steps, please call your system vendor.

Troubleshooting Steps: No Video

1. Check the connection to the ac outlet.
2. Check the voltage setting on the power supply (115 V ac in the U.S.).
3. Check that the frequency/switch selection matches the speed of the Alpha chip.
4. Check that the CPU fan is connected and spinning.
5. Ensure that the flash ROM update procedure was performed correctly. If you have a terminal attached to COM1, check the output for error messages after verifying that the flash ROM update procedure was performed correctly.
6. Reseat the video card and ensure that it is connected to the monitor.

Beep Codes

7. Reseat the DIMMs.
8. Replace the DIMMs.

8.3 Beep Codes

The beep codes provide error information about the AlphaPC 164SX system. Table 8–1 lists and describes the beep codes.

Table 8–1 Beep Codes

Beep Code	Description
1–2–3 ¹	This sequence represents the fail-safe booter startup.
4	No valid header found in ROM; loading entire ROM.
5	No memory found.
6	Checksum error detected when image was read back from memory.

¹ One beep and a pause, followed by two beeps and a pause, followed by three beeps.

8.4 Post Codes

The post codes indicate the progress of the SROM and AlphaBIOS firmware. Table 8–2 lists and describes the post codes.

Table 8–2 Post Codes

(Sheet 1 of 2)

Source	Post Code (hex)	Description
SROM	00	Firmware initialization is complete
	01	CPU speed detected
	02	CPU speed converted
	03	Configuration jumpers read
	04	Bcache configuration value computed
	05	Bcache control value computed
	0C	Memory sized and memory bank 0 written
	0D	Enable Dcache
	13	All of memory rewritten (good data parity written)
	14	Memory errors cleared; start reading system ROM
	15	Loading ROM without SROM decompression
	16	Loading ROM using SROM decompression
	17	System ROM loaded to memory

Table 8–2 Post Codes

(Sheet 2 of 2)

Source	Post Code (hex)	Description
	18	Icache flush code written to memory
	19	CPU errors cleared; jump to system code
	20	ISA bus reset
	3A	Jump to Mini-Debugger
	3F	Fatal error. Second code identifies source of error: 05 = No memory found 06 = Checksum error detected when image was read back from memory
AlphaBIOS	98	Firmware has control
	97	Buses initialized
	95	Video console opened
	51	FATAL - returned from boot menu selection
	50	FATAL - firmware fatal error
	42	Firmware drivers have been started
	00	Firmware has been initialized
Fail-safe booter	FD	I/O bus initialization
	FC	I/O initialization complete
	FB	UART initialization
	BF	Fail-safe booter is scanning the diskette
	1	Fail-safe booter is loading the Windows NT AlphaBIOS
	2	Fail-safe booter is loading the Debug Monitor
	3	Fail-safe booter is loading the SRM console
	4	Fail-safe booter is loading the Linux mini-loader

8.5 Fail-Safe Booter

The fail-safe booter provides an emergency recovery mechanism when the primary firmware image contained in flash memory has been corrupted. When flash memory has been corrupted, and no image can be loaded safely from the flash, you can run the fail-safe booter and boot another image from a diskette that is capable of reprogramming the flash.

Fail-Safe Booter

Starting the Fail-Safe Booter

You can start the fail-safe booter in one of two ways:

- If the primary firmware image is unavailable when the system is powered on or reset, the fail-safe booter runs automatically. When the fail-safe booter runs, the system emits a series of beeps through the speaker as beep code 1-2-3; that is, one beep and a pause, followed by two beeps and a pause, followed by three beeps. After the diskette activity light flashes, insert the *AlphaPC 164SX AlphaBIOS Firmware* diskette. The fail-safe booter will load and run AlphaBIOS from this diskette. Proceed to Section 7.1.3 and follow the procedure for updating your flash ROM.
- You can also start the fail-safe booter manually as follows:
 1. Power off your system.
 2. Slide switch CF7 to off, as described in Section 3.4.
 3. Power on your system.
 4. Insert the *AlphaPC 164SX AlphaBIOS Firmware* diskette into the diskette drive.
 5. Proceed to Section 7.1.3 and follow the procedures.

8.6 Windows NT Startup

While booting the Windows NT operating system, you may receive one of the following error messages:

- The required system file DISPLAY_DRIVER.DLL is bad or missing.
- The required system file DISPLAY_DRIVER.SYS is bad or missing.

These error messages indicate video driver problems. Use the following chart to solve common video driver problems.

If the...	Then...
Driver becomes disabled	Boot the Windows NT operating system with the last known good configuration.
Incorrect video driver is chosen while installing the Windows NT operating system	Reinstall the Windows NT operating system with the correct driver.
New video card was installed before the driver was installed	Reinstall the old video card, boot the Windows NT operating system, and install the driver for the new video card. Then install the new video card and reboot the Windows NT operating system.

Battery Recycle/Disposal Information

NOTICE

Recycle or dispose of batteries promptly in accordance with your organization's environmental policies. If this is a LITHIUM battery, the following additional precautions may apply:

- Replace batteries correctly to prevent possible explosion.
- Replace batteries with the same or equivalent type.
- Prior to disposal or recycling, protect all batteries against accidental short circuiting by affixing nonconductive tape across battery terminals or conductive surfaces.
- Keep batteries away from small children.

Support, Products, and Documentation

A.1 Customer Support

The Alpha OEM website provides the following information for customer support.

URL	Description
http://www.digital.com/alphaoem	Contains the following links: <ul style="list-style-type: none">• Developers' Area: Development tools, code examples, driver developers' information, and technical white papers• Motherboard Products: Motherboard details and performance information• Microprocessor Products: Microprocessor details and performance information• News: Press releases• Technical Information: Motherboard firmware and drivers, hardware compatibility lists, and product documentation library• Customer Support: Feedback form

Supporting Products

A.2 Supporting Products

This section lists sources for components and accessories that are not included with the AlphaPC 164SX.

A.2.1 Memory

Dual inline memory modules (DIMMs) are available from a variety of vendors. For a list of the qualified vendors, visit the Alpha OEM World Wide Web Internet site at URL:

<http://www.digital.com/alphaoem>

Click on **Technical Information**.

Then click on **Alpha OEM Hardware Compatibility List**.

A.2.2 Thermal Products

Components included in this heat-sink and fan solution are heat sink, GRAFOIL pad, two hex nuts, heat-sink clips, 52-mm fan, and four screws. These are available from:

United Machine and Tool Design Company, Inc.

18 River Road
P.O. Box 168
Fremont, NH 03044
Phone: 603-642-5040
Fax: 603-642-5819
PN 70-33148-01

A.2.3 Power Supply

An ATX form-factor power supply, suitable for use with the AlphaPC 164SX (+3.3 V, +5 V, -5 V, +12 V, -12 V), is available from:

Quantum Power Labs, Inc.

1410 Gail Borden Place C-4
El Paso, TX 79935
Phone: 915-599-2688
Fax: 915-599-2699
PN AP2-5300FRV (300 W)

Antec, Inc.

2859 Bayview Drive
Fremont, CA 94538
Phone: 510-770-1200, ext. 313
PN PP-253V (250 W)

A.2.4 Enclosure

An enclosure, suitable for housing the AlphaPC 164SX and its power supply, is available from:

Delta Axxion Technology

1550 Northwestern
El Paso, TX 79912
Phone: 915-877-5288
PN DL17

A.3 Associated Documentation

You can order the following associated documentation directly from the vendor.

If you have feedback about the Alpha technical documentation, please send your comments to alpha.techdoc@compaq.com.

Title	Vendor
Alpha Architecture Reference Manual EY-W938E-DP	Call your sales office or call Butterworth-Heinemann (DIGITAL Press) at 1-800-366-2665
Alpha Architecture Handbook EC-QD2KB-TE	Order online: http://www.digital.com/alphaoem
Alpha 21164PC Microprocessor Hardware Reference Manual EC-R2W0A-TE	See previous entry
Alpha 21164PC Microprocessor Data Sheet EC-R2W1A-TE	See previous entry

Associated Documentation

Title	Vendor
PCI Local Bus Specification, Revision 2.1	PCI Special Interest Group
PCI Multimedia Design Guide, Revision 1.0	U.S. 1-800-433-5177
PCI System Design Guide	International 1-503-797-4207
PCI-to-PCI Bridge Architecture Specification, Revision 1.0	Fax 1-503-234-6762
PCI BIOS Specification, Revision 2.1	
CY82C693U hyperCache/Stand-Alone PCI Peripheral Controller with USB Data Sheet	Cypress Semiconductor Corporation 3901 North First Street San Jose, CA 95134 Phone: 1-800-858-1810
Super I/O Floppy Disk Controller with Infrared Support (FDC37C669) Data Sheet	Standard Microsystems Corporation 80 Arkay Drive Hauppauge, NY 11788 Phone: 1-800-443-7364 Fax: 1-516-231-6004