

digital

LIFE

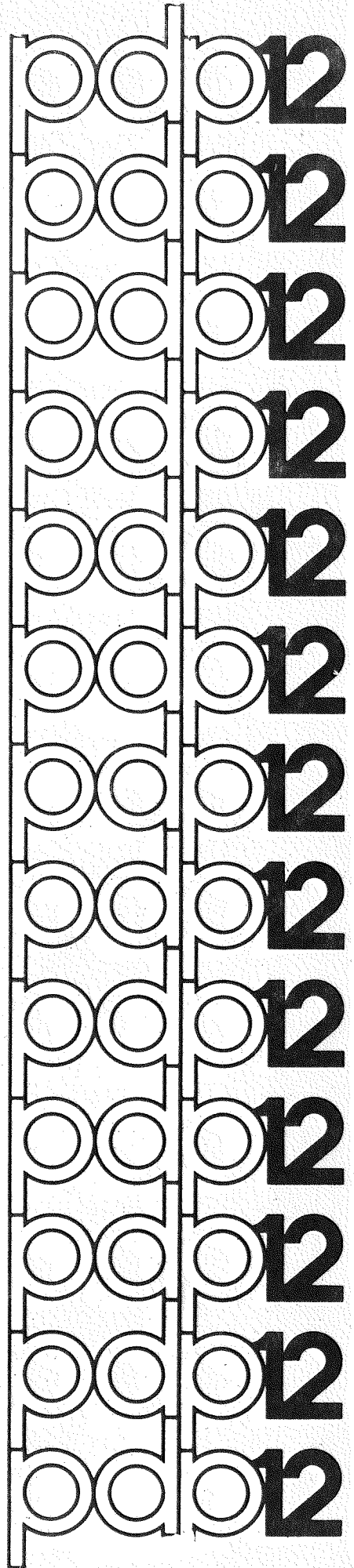

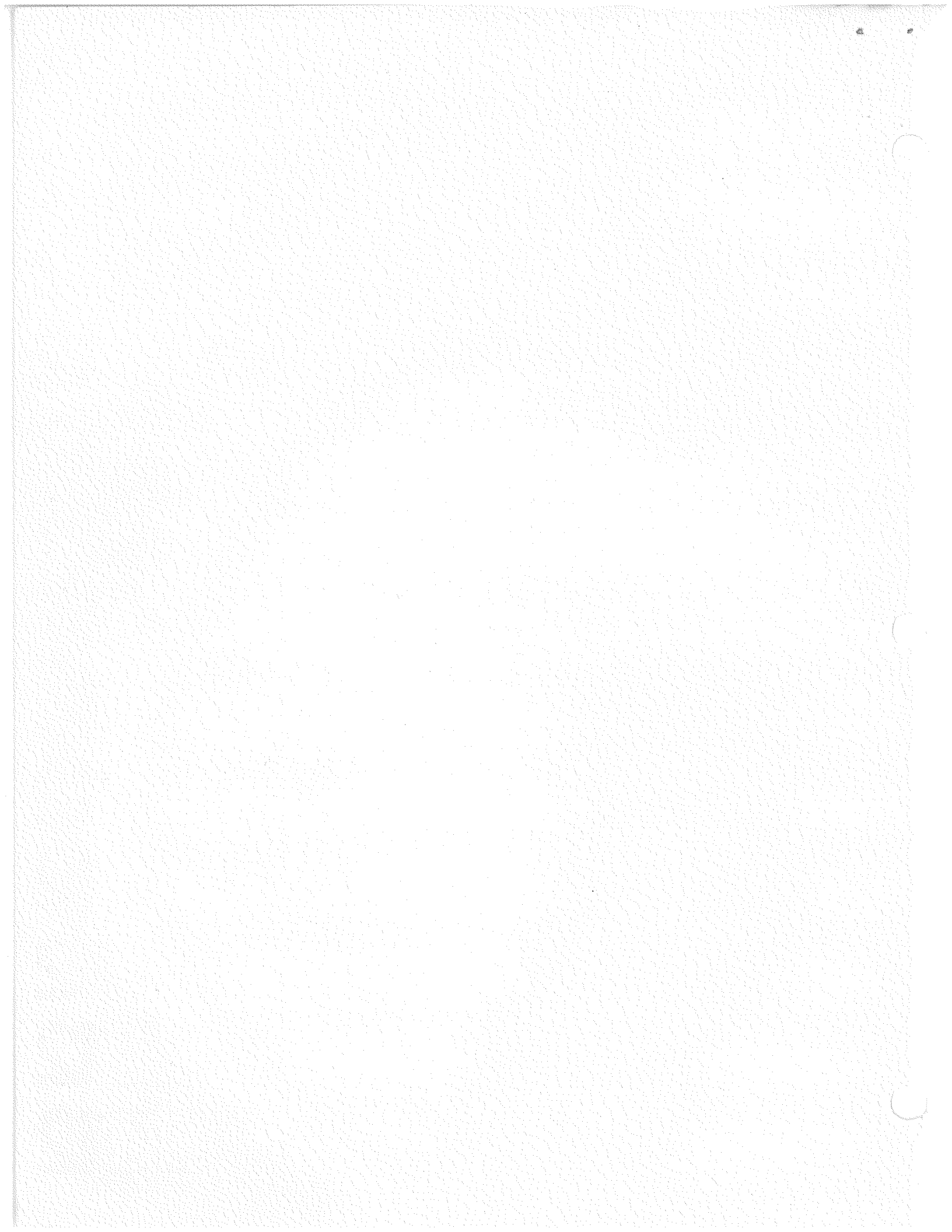

TABLE OF CONTENTS

1.0	INTRODUCTION	1
2.0	HARDWARE REQUIREMENTS	1
3.0	INITIAL STARTING PROCEDURE	1
4.0	OPERATING PROCEDURES	1
4.1	INITIALIZATION	1
4.2	CHOICE 1 - GENERATE NEW SPECTRUM	3
4.2.1	Instrument Definition	3
4.2.2	Spectrum Definition	4
4.2.3	Commands	6
	Halve Display Size	6
	Double Display Size	6
	Baseline Correction	7
	Offset	7
	Fix Point Value	7
	Print Selected Peak Points	9
	Exit	9
	Identify Unknown Spectrum	10
4.3	CHOICE 2 - PRINT	13
4.4	CHOICE 3 - ERASE	15
4.5	CHOICE 4 - RETURN TO DIAL	16
5.0	ERROR MESSAGES	16
6.0	ASSEMBLY INSTRUCTIONS	16
APPENDIX A	SUMMARY OF DISPLAYED MESSAGES	A-1
APPENDIX B	CORE MAP	B-1
APPENDIX C	LIFE DATA TAPE	C-1
APPENDIX D	SPECTRUM DATA INDEX BLOCK Ø	D-1
APPENDIX E	SPECTRUM DATA BLOCKS	E-1
APPENDIX F	FLOWCHARTS	F-1
INDEX		i

DEC-12-UW8B-D
January, 1971
REPRINTED AUGUST, 1971

Copyright © 1970 by Digital Equipment Corporation

The material in this handbook, including but not limited to instruction times and operating speeds, is for information purposes and is subject to change without notice.

The following are trademarks of Digital Equipment Corporation, Maynard, Massachusetts:

DEC	PDP
FLIP CHIP	FOCAL
DIGITAL	COMPUTER LAB

The equipment described herein is covered by patents and patents pending.

For additional copies order DEC-12-UW8B-D from Program Library, Digital Equipment Corporation, 146 Main Street, Maynard, Mass. 01754 Price \$5.00

1.0 INTRODUCTION

LIFE (Library File Entry) is a data storage and retrieval program designed to characterize and store data acquired with the PDP-12 Signal Processing Programs. Prominent features of the spectrum are located using an interactive display and then characterized and stored on LINC-tape or disk (RK8 or RF08) as an independent entry in a LIFE "library" of spectra data. An unknown sample can then be identified by comparing its spectrum with spectra of known library samples (fingerprinting) for that instrument.

2.0 HARDWARE REQUIREMENTS

The minimum configuration for using LIFE is:

PDP-12A computer with 8K of core memory

The program does not require, but will support, an RK8 or RF08 disk.

3.0 INITIAL STARTING PROCEDURE

LIFE runs under and must be loaded via LAP6-DIAL-MS¹ using the command

```
→ LO LIFE,n )
```

where n is the unit containing LIFE. DIAL-MS must be on logical unit 0, regardless of the value of n.

4.0 OPERATING PROCEDURES

4.1 Initialization

LIFE indicates that it has been successfully loaded into the computer by displaying the following message:

Message 1

```
LIFE IS CREATED  
LIFE UNIT --
```

¹Hereafter referred to as DIAL-MS.

The tape/disk unit which contains the LIFE library must be defined by typing a one or two digit number followed by line feed on the teleprinter. Any of the DIAL-MS device unit numbers are applicable (refer to the LAP6-DIAL Programmer's Reference Manual, DEC-12-SE2D-D). (All scope messages are presented using the QANDA subroutine, DEC-12-FISA-D. It is assumed that the user is familiar with the conventions of QANDA. Briefly, they are: 1. The last reply to a scope message is terminated by pressing line feed. 2. Replies other than the last one to any scope message are terminated by pressing carriage return.)

At this time, the LIFE library unit must be on-line to the PDP-12 and its WRITE feature must be enabled. If it is not, the program will wait until either the I/O PRESET key is pressed, in which case the LIFE program may be reloaded, or until the above conditions are satisfied. The program then interrogates the defined LIFE tape/disk and displays the following message if the tape/disk has never been initialized by the LIFE program:

Message 2

```
NOT LIFE TAPE
INITIALIZE? Y OR N: _
```

Entering a Y and pressing line feed will cause the tape/disk on the defined unit to be initialized.

Typing an N and line feed will cause message 1 to be displayed and no initialization will take place.

If the tape/disk was initialized, all other characters are ignored, or if a Y was entered in response to message 2, the following message is displayed:

Message 3

```
FUNCTIONS:
1. GENERATE NEW SPECTRUM
2. PRINT
3. ERASE
4. CALL DIAL

CHOICE: _
```

The four major modes of operation are defined in the above message. The user indicates his choice by entering the number (1-4) associated with the chosen mode.

CTRL/R may be typed in response to any subsequent display, causing an immediate return to message 3.

4.2 Choice 1 - GENERATE NEW SPECTRUM

A spectrum which is stored on tape/disk can be displayed using choice 1. A definitive set of parameters can then be entered to the LIFE library tape/disk or the LIFE library tape/disk may be searched for those previously stored spectra which have similar characteristics.

4.2.1 Instrument Definition

The following message is displayed after choice 1 is specified:

Message 4

INSTRUMENT NAME ----

All entries to the LIFE library tape/disk are classified by the instrument from which the sample was taken. Up to 67 different instrument names may be defined; each name may be up to four alphanumeric characters in length.

Once the instrument name for the data has been defined, LIFE interrogates its library tape for a match. If no match is found (i.e., this is the first entry under the particular instrument name) the following message is displayed.

Message 5

NEW INSTRUMENT
ACCEPT? Y OR N: _

TYPE
1 IF X ONLY
2 IF X AND Y

-

To add a new instrument class to the library tape, type Y and press RETURN. The method by which the spectrum data stored under this instrument class must be defined consists of two choices, 1 for X only or 2 for X and Y. X is the position in the file (nth point) and Y is the magnitude (value of the nth point). Therefore, if a new instrument class is to be entered, first type Y, then type 1 or 2 (describing the number of parameters) and line feed.

If a new instrument class is not to be opened (e.g., a typographical error occurred), type N and line feed; LIFE will return to message 4.

4.2.2 Spectrum Definition

In either case, once the instrument name has been defined, the following message is displayed:

Message 6

```
UNIT NAME  ----  
SPECTRUM NAME  -----  
              -----
```

The name assigned to the tape/disk on which the raw data is stored is entered in the first line followed by pressing return. This name can be one to four alphanumeric characters. (NOTE: It is suggested that each tape or disk be labeled or numbered and that this name or number be entered in response to line 1 of message 6.)

The spectrum name is then requested by the LIFE program. This name may be up to 16 alphanumeric characters in length and must be entered in two groups of up to eight characters each. The first group is terminated by a carriage return or line feed. The second is terminated by a line feed. For example,

```
SPECTRUM NAME  SODIUM C  
                ARBONATE
```

or

```
SPECTRUM NAME  STYRENE
```

The location of the defined spectrum is specified next.

Message 7

```
UNIT NUMBER  --  
START BLOCK  ---  
PTS IN SPECTRUM  ----
```

The UNIT NUMBER may be \emptyset -7, defining one of eight tape drives, or $1\emptyset$ -17, defining one of eight logical disk units. The defined unit must be on-line to the PDP-12 at this time. If it is not, the program will wait until the above condition is satisfied.

START BLOCK is a one to three digit octal number (\emptyset -777) defining the starting block of the raw data.

PTS IN SPECTRUM defines the number of points in the spectrum and is a decimal number in the range 513 to $2\emptyset4\emptyset$.

The location of the spectrum is now completely defined and LIFE displays it on the scope. The user may control the position of the display with A/D knob \emptyset . A clockwise motion of knob \emptyset moves the display window to the right; a counter-clockwise motion moves the display window to the left. The farther the knob is rotated from the mid-point position, the faster the window moves. The display is made stationary by leaving knob \emptyset in a middle position between its two extreme positions.

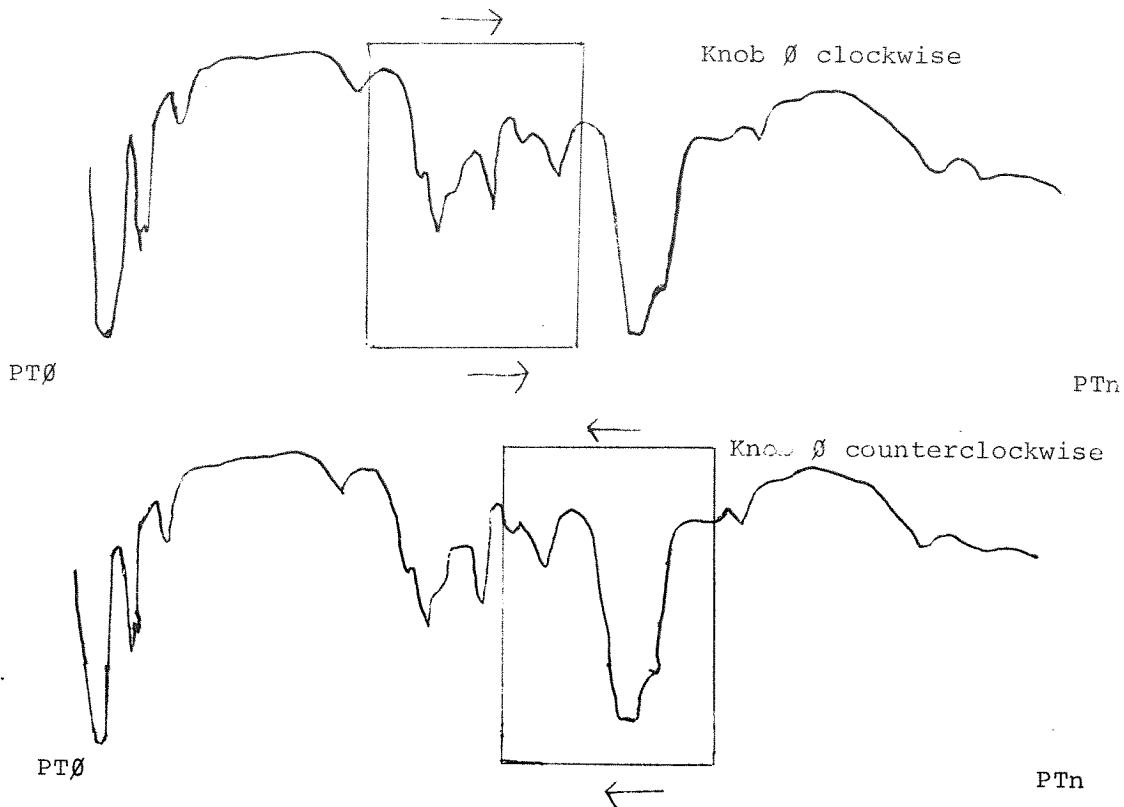

It should be noted that the display window wraps around either end of the file, that is, $PT\emptyset$ and PTn are assumed to be adjacent.

There is also a cursor which is fixed to the curve. A/D knob 1 can be moved clockwise to move the cursor to the right or counterclockwise to move it to the left.

When knob 1 is turned to its furthestmost clockwise (counter-clockwise) position, the cursor sits upon the rightmost (leftmost) scope point.

Associated with the cursor are four octal words displayed in the top left corner of the scope. The first word will always be zero. The second word is the actual core address of the cursor point. Its range is from 2000 (representing the first point of the file) to 5770. For example, if the defined file contains 1001 octal points (513 decimal), this word will range from 2000 to 3000, where 2000 represents the first point of the file and 3000 the 513th point of the file. The third word is the octal equivalent of the contents of the cursor point (i.e., the actual 12 bit value in the data buffer of the data word which corresponds to the cursor point) and is in the range 0 to 1000₈ (top to bottom), where the center value is 400₈. The fourth word is relative to the third word and reflects the Y offset and Y scale and is of no interest to the LIFE user.

4.2.3 Commands

Once the display appears, the Teletype becomes active and the user may enter a number of commands. These command operations are performed immediately; no terminating character is required. They are:

- (halve display size)

The command dash (-) divides each data point by 2 before it is displayed. The actual data is untouched, but the peak heights seen on the scope are smaller.

The dash may be typed repeatedly up to three times (division by 8). It should be noted that the display window returns to the beginning of the file each time dash is typed. The function of the halve command is to enable 12-bit unsigned data (not gathered through the PDP-12 Signal Processing System perhaps) to be processed.

+ (double display size)

Typing a plus sign (via the ; key and the SHIFT key) multiplies the value of the displayed points by 2 each time the key is struck. It may only be used after a dash (the initial display is the largest representation of the data available). Doubling the display size only changes the spectrum displayed; there is no change in the data file. Each time a

plus sign is typed the display window is positioned to the beginning of the spectrum.

B (baseline correction)

When B is typed, the base line of the spectrum is set to the Y axis cursor value. Then the base line is positioned to the vertical center of the scope and the display window returns to the beginning of the spectrum. All subsequent Y values will be interpreted relative to the baseline.

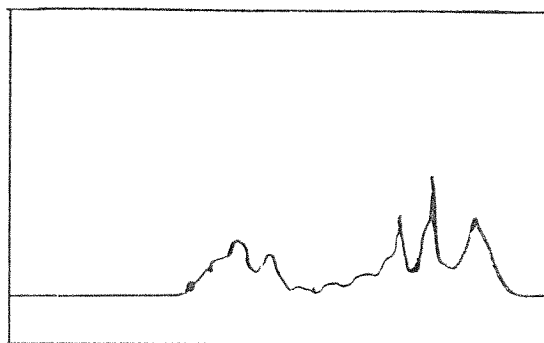
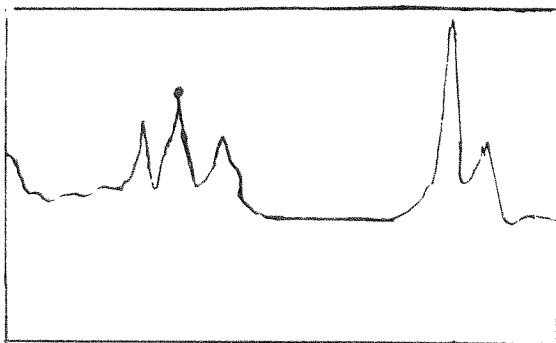

O (offset)

The zero point of the X axis is set to the cursor X value (i.e., the point in the raw data file) which effectively sets the reference point for all future X values. Typically, the cursor would be positioned on a reference or identity peak and then O will be typed. In this way, all library entries for a particular instrument have a common reference point. The spectrum must be offset before any values are fixed or an error message will result. (In that case, fixed values must be deleted with the E command.)

F (fix point value)

Characteristic peaks of the displayed spectrum may be specified by the user to describe the points of interest. These values are stored on the LIFE library tape/disk and used when identifying an unknown spectrum by comparison. A point is fixed by the following procedure.

1. Position the display window (using knob \emptyset) so that the desired peak is in view, and the display has stopped moving.
2. Position the cursor (using knob 1) to the characteristic value of the peak. The third word of the cursor display may be helpful in this positioning.

3. Type F on the Teletype. The value of the cursor point is now recorded and the above procedure may be repeated for the next point of interest.

As many as 95 values may be fixed at a time (190 for a single parameter instrument); at least five must be specified. In addition, each successive X value must be greater than the previously specified X value as determined from the second number displayed in the left corner of the scope.

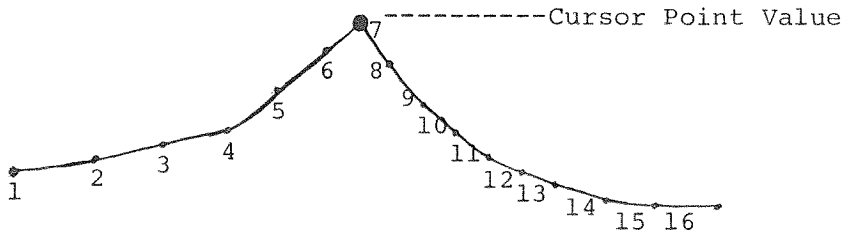

The response to message 5, type of instrument, determines what data is stored.

For one parameter instruments, only the X value is stored. In the above diagram, 7 will be stored if an F is typed at the cursor value shown.

For two parameter instruments, both the X and Y values of the cursor point will be stored. In the above example, X will still be 7. Y will be the difference between the cursor data point value and the baseline value. Note that if the baseline has not been set using the B command, it is assumed to be zero.

In the following example, the O, B, and F commands are used. The bottom horizontal scale shows the X values of the raw data for a 25 point spectrum. The vertical scale shows the Y values of the raw data. The lettered points represent the cursor values.

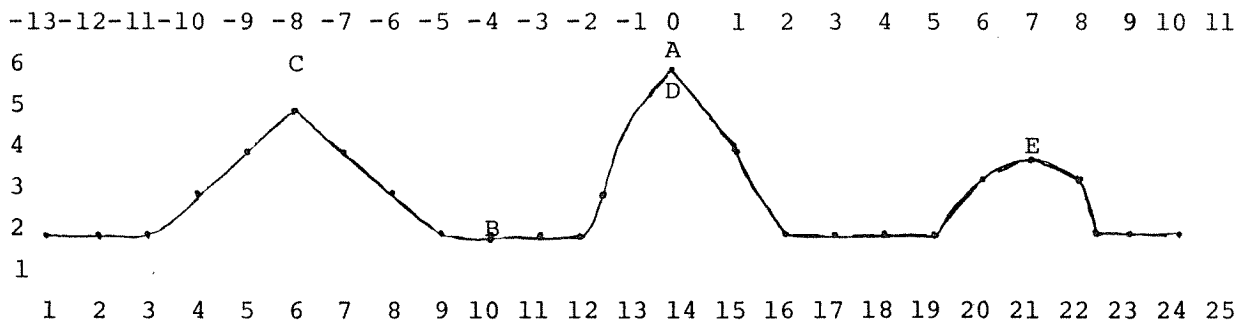

1. First the cursor is moved to position A and O (for offset) is typed to set the X axis zero point at raw data point 14. The top horizontal scale shows the X axis relative to the offset zero point.
2. The cursor is then moved to position B and B (for baseline) is typed. This sets the baseline to a value of 2 on the vertical scale.
3. Finally, the cursor is moved to positions C, D, and E, and F (for fix location) is typed at each position. The values stored are as follows:

<u>Cursor Position</u>	<u>X Value</u>	<u>Y Value</u>
C	-8	3
D	0	4
E	7	2

P (print selected peak points)

The P command allows the user to print out the selected peaks just defined. For the above example, the printout would be as follows:

```

SPECTRUM :    EXAM1
INSTRUMENT :  NMR

PK      X VAL      Y VAL
01     -0008       0003
02       0000       0004
03       0007       0002

```

The above commands are used to define or characterize a spectrum. Each one of them may be implemented at any time and as often as desired. When a spectrum has been completely characterized two options remain:

X (exit)

An exit request will store the fixed spectrum characteristics on the LIFE library tape/disk. If less than five parameters have been defined, an error message will result. If E has purged the list of parameters, or if no parameters were saved, no storage will take place, and the program will redisplay message 3.

U (identify unknown spectrum)

This mode allows the user to search the LIFE library tape for spectra with similar characteristics to the spectrum just defined. The search will include only those spectra which were previously stored under the defined instrument name of the unknown. The comparison will be carried out on those parameters defined by the fix command.

When U is typed, the following sequence of messages is generated:

Message 8

ALLOWABLE ERROR TOLERANCE

1 - PERCENT
2 - ABSOLUTE

CHOICE: _

X TOLERANCE: ---
Y TOLERANCE: ---

Because an exact match of parameters is not likely, LIFE allows the user to specify the allowable error tolerance around a library spectrum peak value within which the defined spectrum peak value being compared may fall and still be considered a match. This tolerance may be specified as a percent of the library peak [\emptyset -99%] or as an absolute difference from the library peak [\emptyset -999].

The choice of percent or absolute tolerances is made in the first line of the above message by typing 1 for percent or 2 for absolute.

X tolerance is the tolerance applied to the X peak parameter. If percent was chosen, its range may be 0% to 99% of the library peak. If absolute was chosen, its range may be \emptyset to 999 (decimal). Y tolerance is the tolerance applied to the Y peak. Its restraints are the same as those for the X tolerance. Y tolerance will be ignored if the instrument's spectra contain only X values.

The tolerance, whether percent or absolute, extends to both sides of the library peak value. Therefore, a match exists for X values between X_L of the library spectrum and X_U of the unknown spectrum if the following condition is true:

$$X_L - TOL < X_U < X_L + TOL$$

where

$$\text{TOL} = \text{X VALUE (absolute)}$$

or

$$\text{TOL} = X_L \cdot \frac{\text{X VALUE (percent)}}{100}$$

The next display for identifying unknown spectra is:

Message 9

MISSES ALLOWED --

The number of misses, or non-matches, that will be accepted in the comparison of the peaks of two spectra must be specified. This number may range from 0 to 94 and must be less than the number of fixed peaks in the unknown spectrum, because the matching algorithm determines that each peak in the smaller [fewer peaks] of the two spectra being compared is either a "match" or a "miss". If the number of misses is greater than the number of points in the unknown, each library spectrum would be considered a match for that unknown, regardless of the similarity of the spectra.

After the number of misses is specified, the LIFE program will search the LIFE library tape for matching spectra using the restrictions defined above. If no spectra have been saved previously for this instrument, the program returns immediately to the spectrum display. The following is a summary of the matching algorithm for a two parameter [X,Y] instrument. (The matching algorithm for a one parameter [X] instrument is a subset of this algorithm.)

To determine if an unknown spectrum peak matches a library spectrum peak it is necessary to know:

1. which spectrum has fewer fixed peaks [if the number of spectrum peaks are equal, the library spectrum is assumed to be smaller],
2. the X and Y components of this library peak,
3. the X and Y components of the unknown peak,
4. the absolute tolerance [if a percent tolerance was chosen it is now multiplied first by the library peak X component to yield the absolute X tolerance for this peak, and then by the library peak Y component to yield the absolute Y tolerance].

It is assumed that, for both spectra, all peak X values are in ascending order.

For the program to consider the library peak with which to "match" the unknown peak, it is necessary that:

- a. $LIB\ X\ VAL - XTOL < UNK\ X\ VAL < LIB\ X\ VAL + XTOL$
- b. $LIB\ Y\ VAL - XTOL < UNK\ Y\ VAL < LIB\ Y\ VAL + YTOL$

If both conditions are true, the peaks match, and the next peak in each spectrum is considered.

If either one is untrue, the peaks do not match, but a "miss" is not yet said to occur. [A "miss" is a peak on the smaller of the two spectra that does not match any peak on the larger]. A miss will occur for a peak if the following are true:

1. the peak is on the smaller spectrum,
2. the peak X value is less than the X value of the larger spectrum,
3. the matching criteria a and b above are not met.

If the matching criteria are not met, the spectrum peak with the smaller X value is replaced with the next peak from that spectrum, and a new comparison is made.

Whenever the number of missed peaks on the smaller spectrum exceeds the number of misses specified, the program immediately reinitializes and starts comparing the unknown to the next library spectrum [if any].

If all spectrum peaks on the smaller spectrum have been compared, and the allowed number of misses has not been exceeded, the library spectrum is output as a match for the unknown.

If all spectrum peaks on the larger spectrum have been compared, all remaining uncomparred peaks on the smaller spectrum are considered as misses, and the decision to output is made immediately thereafter.

The following is an example of the printout that will occur during the matching operation:

UNKNOWN:

SPECTRUM	PK, PTS
T-BUTCL2	50

LIBRARY:

SPECTRUM	PK, PTS	MISSES
T-BUTCL2-SAM1	60	1
T-BUTCL2-SAM2	43	2
T-BUTCL2-SAM3	54	0

Note that either the library spectrum or the unknown spectrum may be a subset of the other, and a match will still occur.

When the matching operation has been completed, LIFE returns to the display mode and the +, -, B, O, F, P, X, and U commands again become active.

4.3 Choice 2 - PRINT

After initialization, the PRINT mode generates on the teleprinter the index of the LIFE library tape/disk unit or the peak values for a particular spectrum for a specified instrument.

The initial PRINT display is:

Message 11

1. INDEX
2. LIBRARY SPECTRUM
3. EXIT

CHOICE_

Type the appropriate number 1 to 3.

Typing 1 prints an index containing the instrument's name, spectrum name, unit name, starting block and number of points fixed similar to the following. The order in which the spectra are listed is the order in which they were placed on tape.

INDEX OF LIBRARY SPECTRA

INSTRUMENT	SPECTRUM NAME	TAPE NAME	STARTING BLK	PKS
NMR	ODCB	DEC	010	0018
NMR	PYRIDINE	DEC	160	0032
NMR	INDENE	DEC	170	0025
NMR	DIOXANE W/ C13	DEC	220	0012
NMR	TETRAGLYME	DEC	230	0014
NMR	DIPHENYL METHANE	DEC	240	0007
NMR	TETRAHYDROFURAN	DEC	250	0020
NMR	XYLENOL	DEC	260	0007
NMR	POLYSTYRENE	DEC	270	0014
NMR	METHYL FORMAMIDE	DEC	320	0026
NMR	DIMETHOXYNAPHTHA	DEC	350	0012
NMR	T-BUTANOL	DEC	370	0015
NMR	T-BUTCL2-SAM1	DEC	390	0060
NMR	T-BUTCL2-SAM2	DEC	410	0043
NMR	T-BUTCL2-SAM3	DEC	430	0094
NMR	T-BUTCL2	DEC	450	0090

Typing 2 displays the following message:

Message 12

```

INSTRUMENT NAME  ----
SPECTRUM NAME   -----
                -----
    
```

See message 4 and message 6 for the acceptable response sequence for message 12.

The number of peaks printed is the number of peaks that were fixed. A sample printout has the format:

```

SPECTRUM 1      T-BUTANOL
INSTRUMENT 1    NMR
PK      X VAL      Y VAL
01      -0033      0044
02      -0026      0051
03      0050      0129
04      0054      0053
05      0077      0084
    
```

At the completion of either printout, LIFE returns to message 3.

Typing 3 causes LIFE to return directly to message 3.

4.4 Choice 3 - ERASE

The ERASE mode permits deletion of the entire LIFE library (essentially reinitialize the tape), an entire instrument type, or a single spectrum.

The first message displayed for the ERASE option is:

Message 13

```
ERASE
1.  ENTIRE LIBRARY
2.  ENTIRE INSTRUMENT
3.  SINGLE SPECTRUM
4.  EXIT
```

CHOICE_

The choice is made by typing the appropriate number followed by line feed.

If 1 is typed, the LIFE library is to be reinitialized, removing all files from the library tape/disk. A warning message is displayed first to minimize accidentally destroying a library tape.

Message 14

SURE?_

Type Y if the whole tape is to be erased; type N if this was an incorrect choice. Message 3 is displayed after either response.

Typing 2 indicates that an instrument name is to be deleted from the LIFE library tape/disk. The following message is displayed:

Message 15

INSTRUMENT NAME ----

Refer to message 4 for the response syntax. The instrument name and all the associated spectra are then deleted from the LIFE library tape/disk and message 3 is displayed.

If 3 is typed, a particular spectrum is deleted from the LIFE library tape/disk. Message 12 is displayed in order to define the spectrum to be deleted. Refer to message 6 for the response syntax. After typing the reply, the spectrum is deleted and message 3 is displayed.

A response of 4 to message 13 causes LIFE to return to message 3.

4.5 Choice 4 - RETURN TO DIAL

After initialization, the user may return to the DIAL system by typing 4 on the teleprinter.

5.0 ERROR MESSAGES

An error will be indicated by a message in the form

```
ERROR
N
PRESS LINE FEED    TRY AGAIN
```

where N is one of the following numeric error codes:

1. ATTEMPTED TO ADD SPECTRUM THAT WAS ALREADY IN LIFE FILES.
2. ILLEGAL CHARACTER TYPED.
3. OFFSET [O] REQUESTED, BUT PEAK VALUES HAVE ALREADY BEEN SAVED.
6. NUMBER OF MISSES REQUESTED > NUMBER OF POINTS IN UNKNOWN SPECTRUM.
7. ATTEMPTED TO SAVE A SPECTRUM WHOSE NUMBER OF PEAKS IS NOT BETWEEN 5 AND 95.
8. X VALUE OF CURRENT PEAK \leq X VALUE OF LAST PEAK STORED. F COMMAND CANNOT BE CARRIED OUT.
9. NO MORE ROOM ON LIFE UNIT [INDEX OR BLOCKS].

6.0 ASSEMBLY INSTRUCTIONS

There are four subprograms to the LIFE system, which are assembled together via the chaining feature of DIAL-MS. They are:

```
LIFE B0    [resides in instruction field 0]
LIFE B4    [resides in instruction field 4]
LIFE B6    [resides in instruction field 6]
LIFE B5    [resides in instruction field 5]
```

To assemble LIFE, the command is simply

```
→ AS LIFE B01,0 )
```

assuming the DIAL-MS tape containing LIFE is mounted on unit 0.

To save the binary, the proper DIAL command is:

→ SB LIFE,0,L10026,

APPENDIX A

SUMMARY OF DISPLAYED MESSAGES

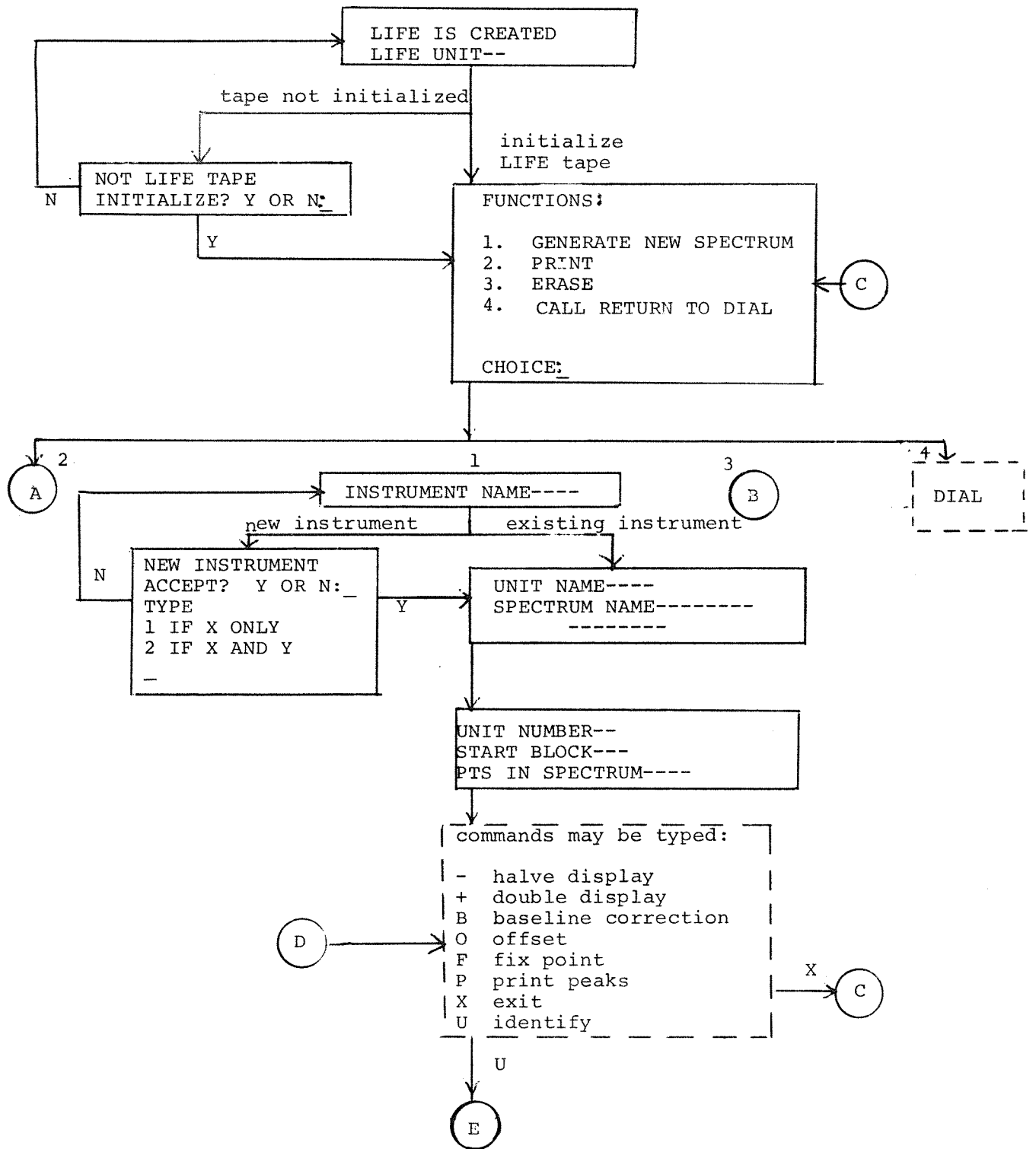

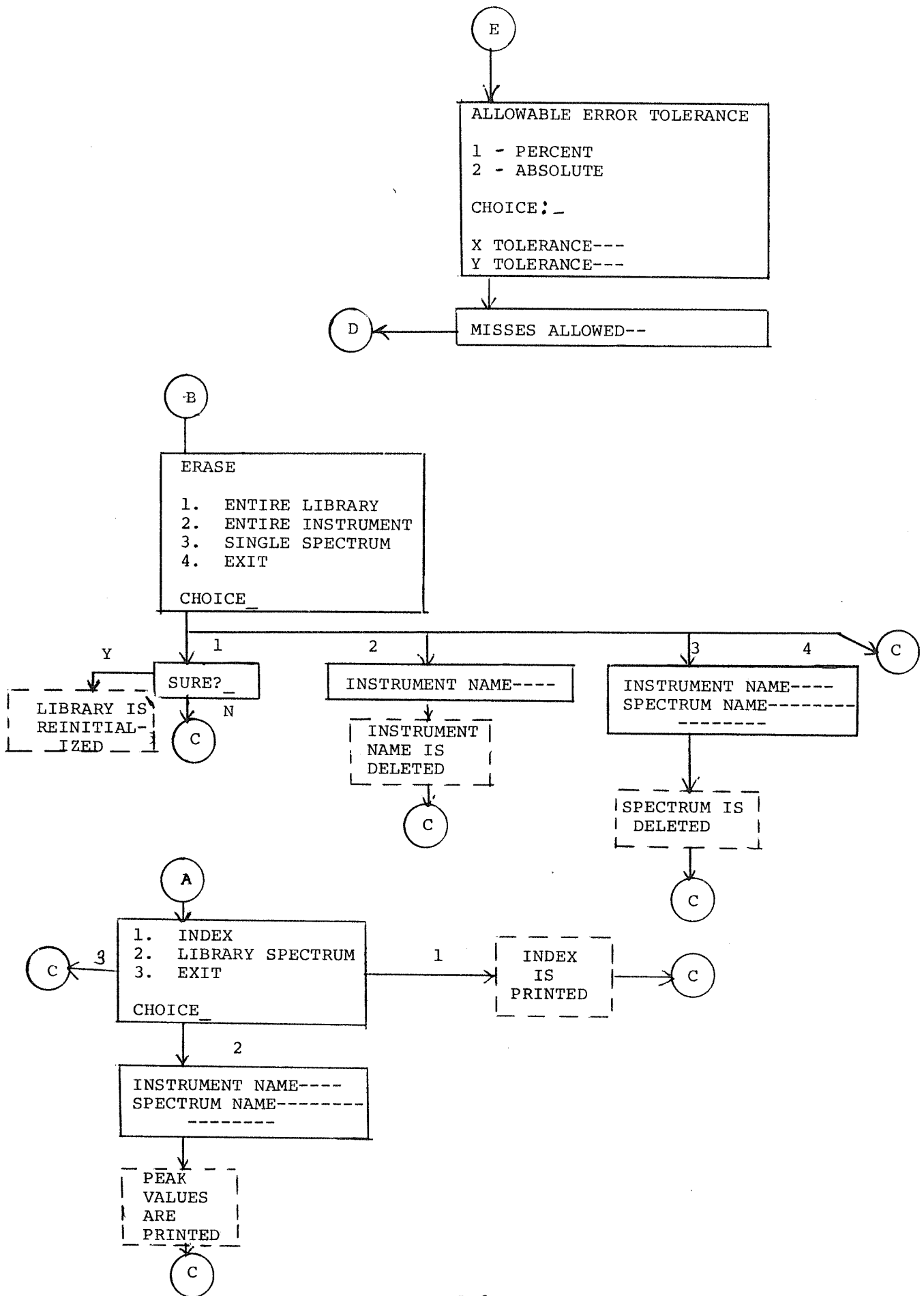

APPENDIX B

CORE MAP

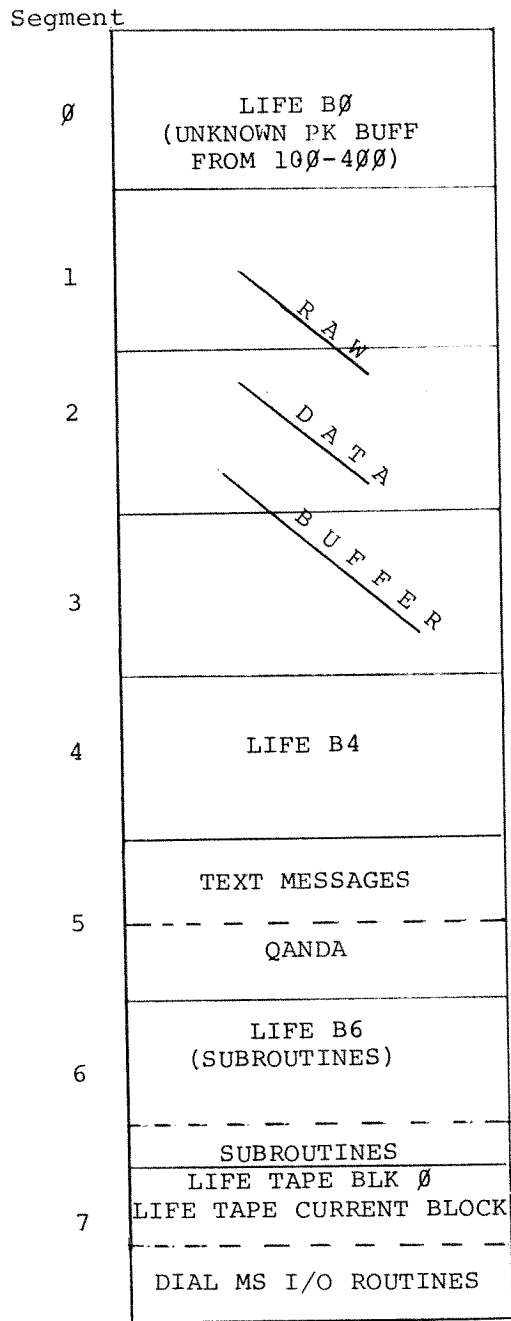

APPENDIX C

LIFE DATA TAPE

BLK 0

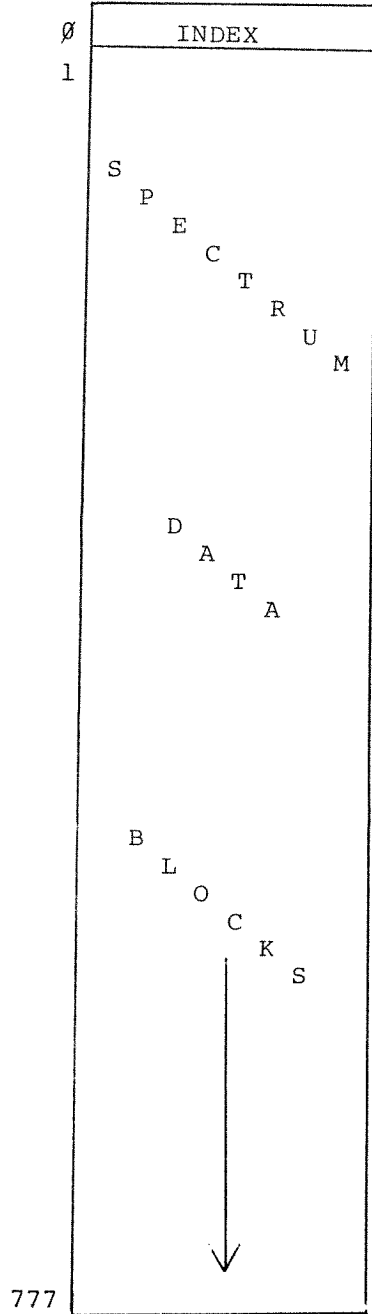

APPENDIX D

SPECTRUM DATA INDEX (BLOCK 0)

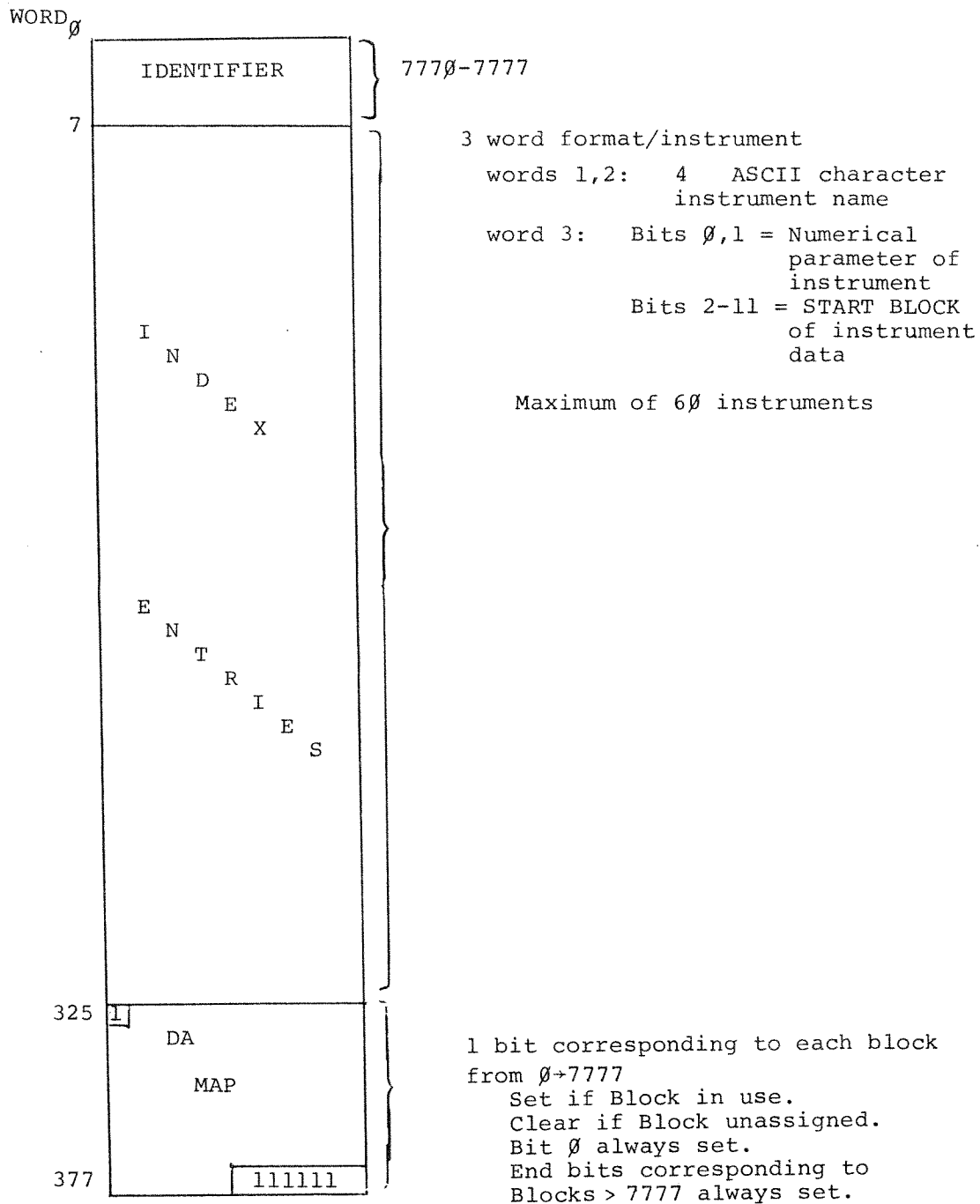

APPENDIX E

SPECTRUM DATA BLOCKS

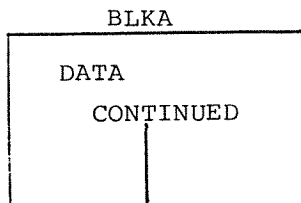
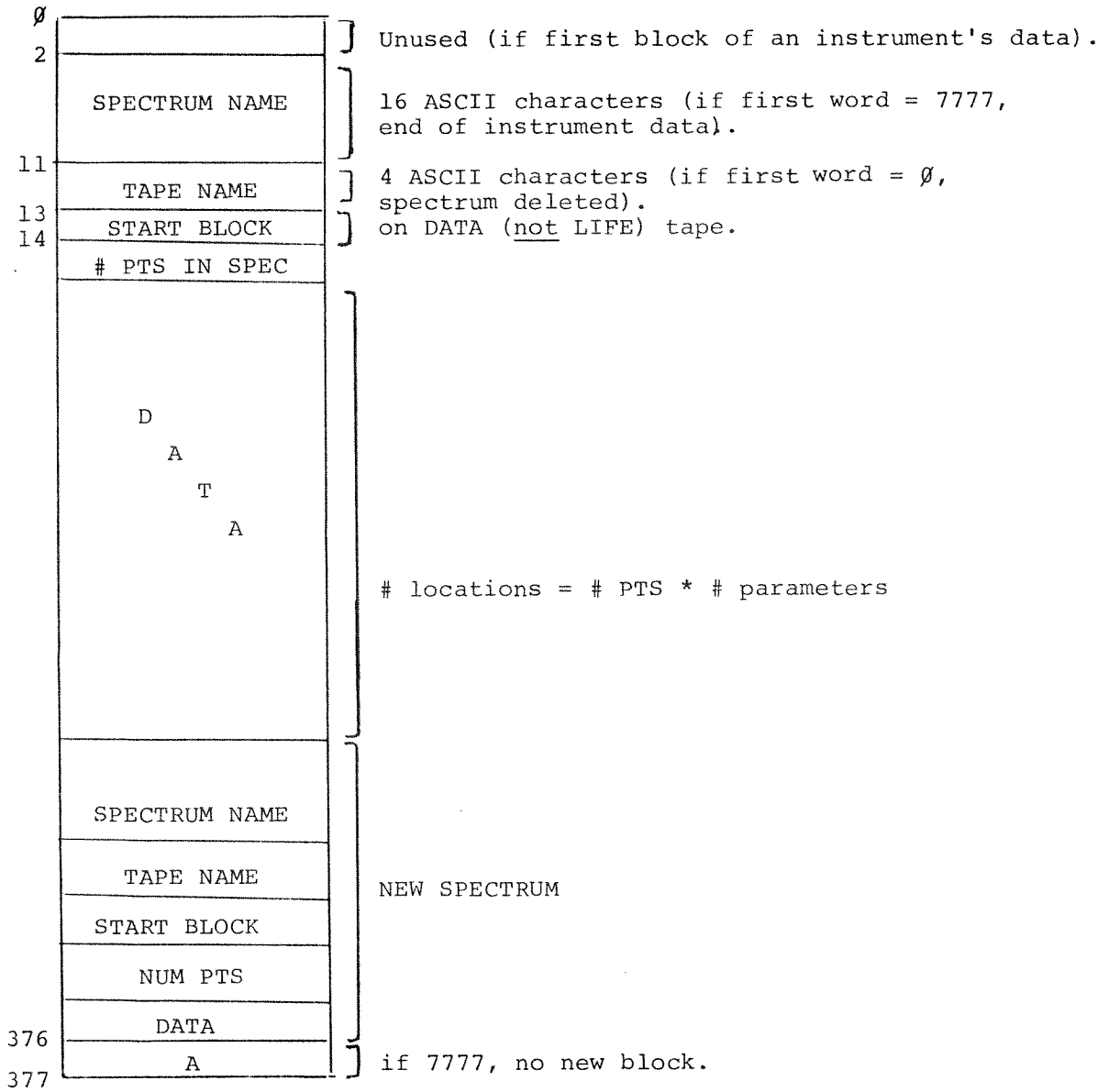

APPENDIX F

FLOWCHARTS

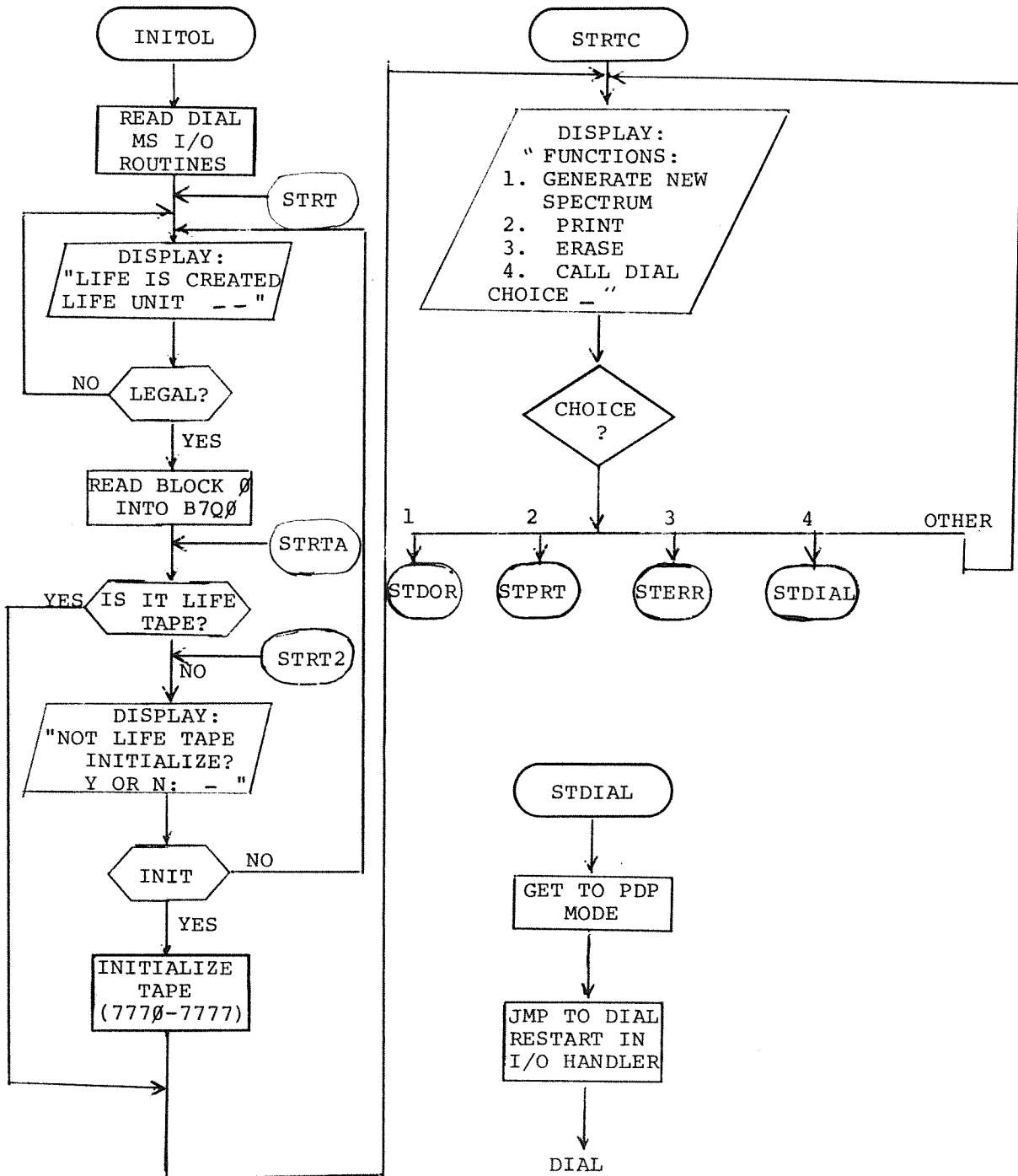

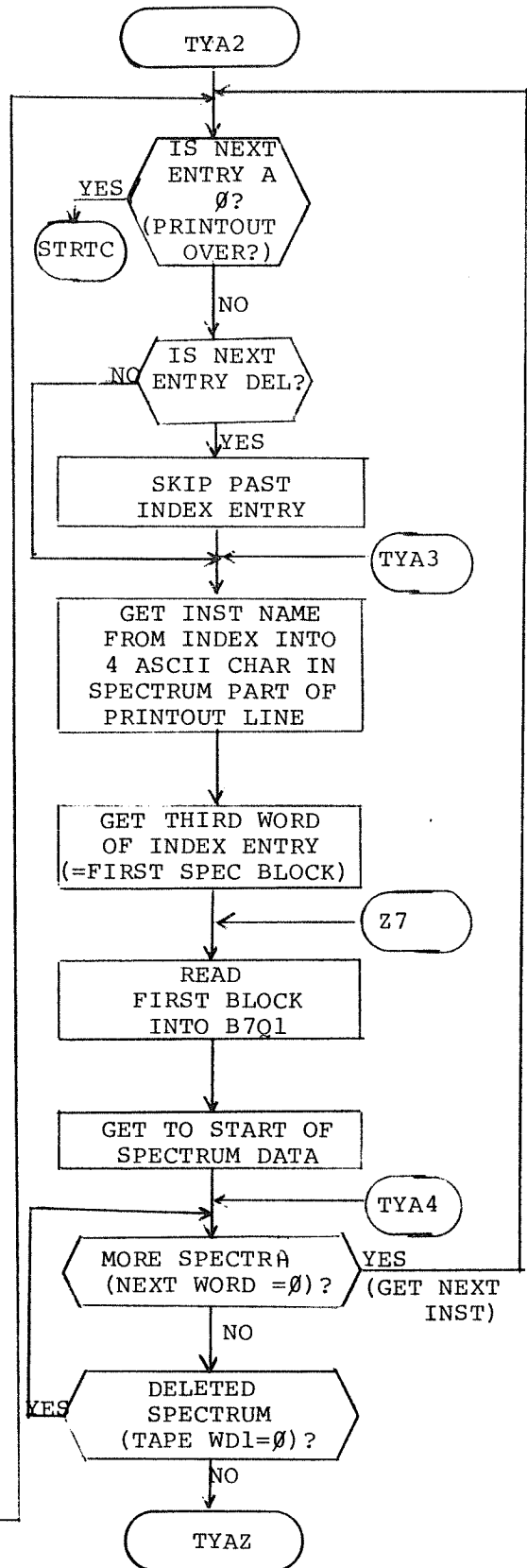
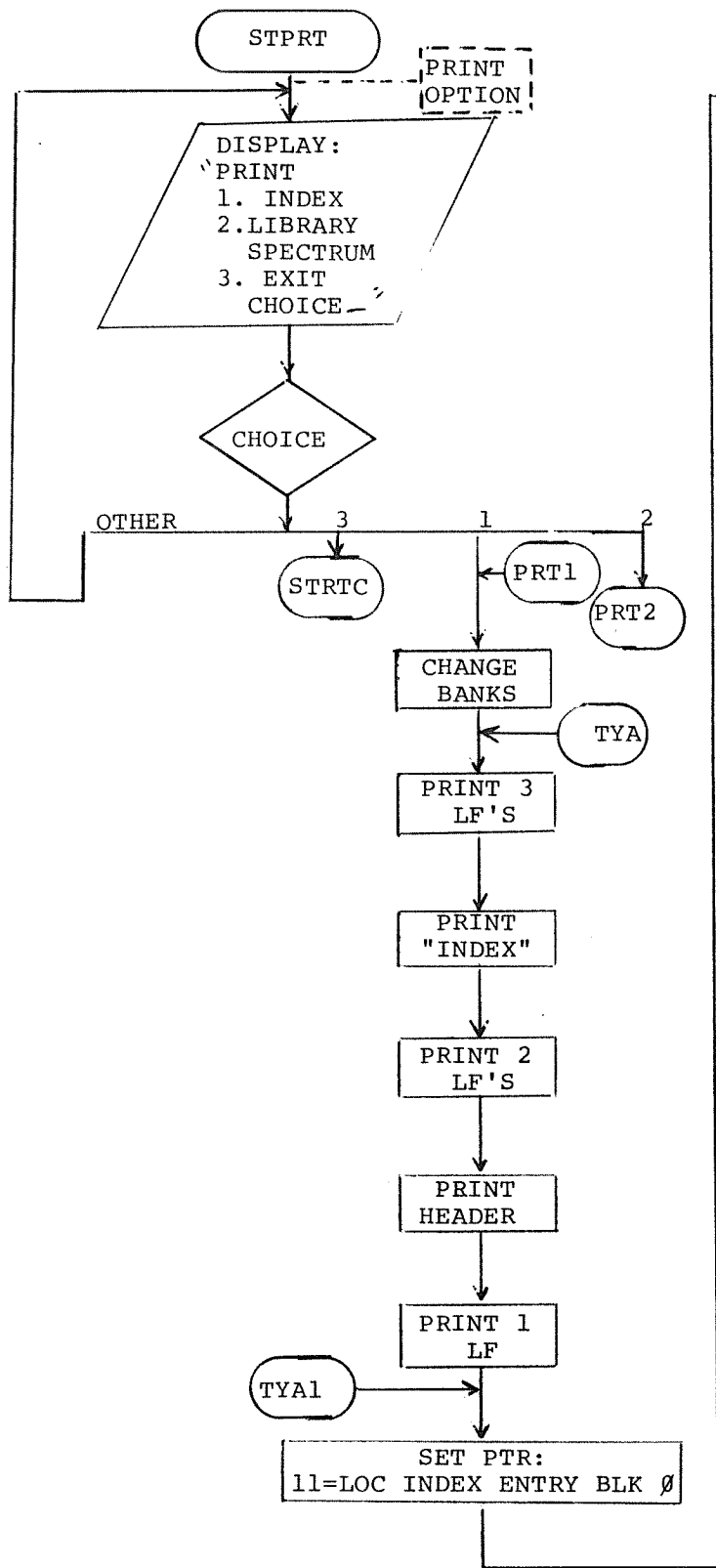

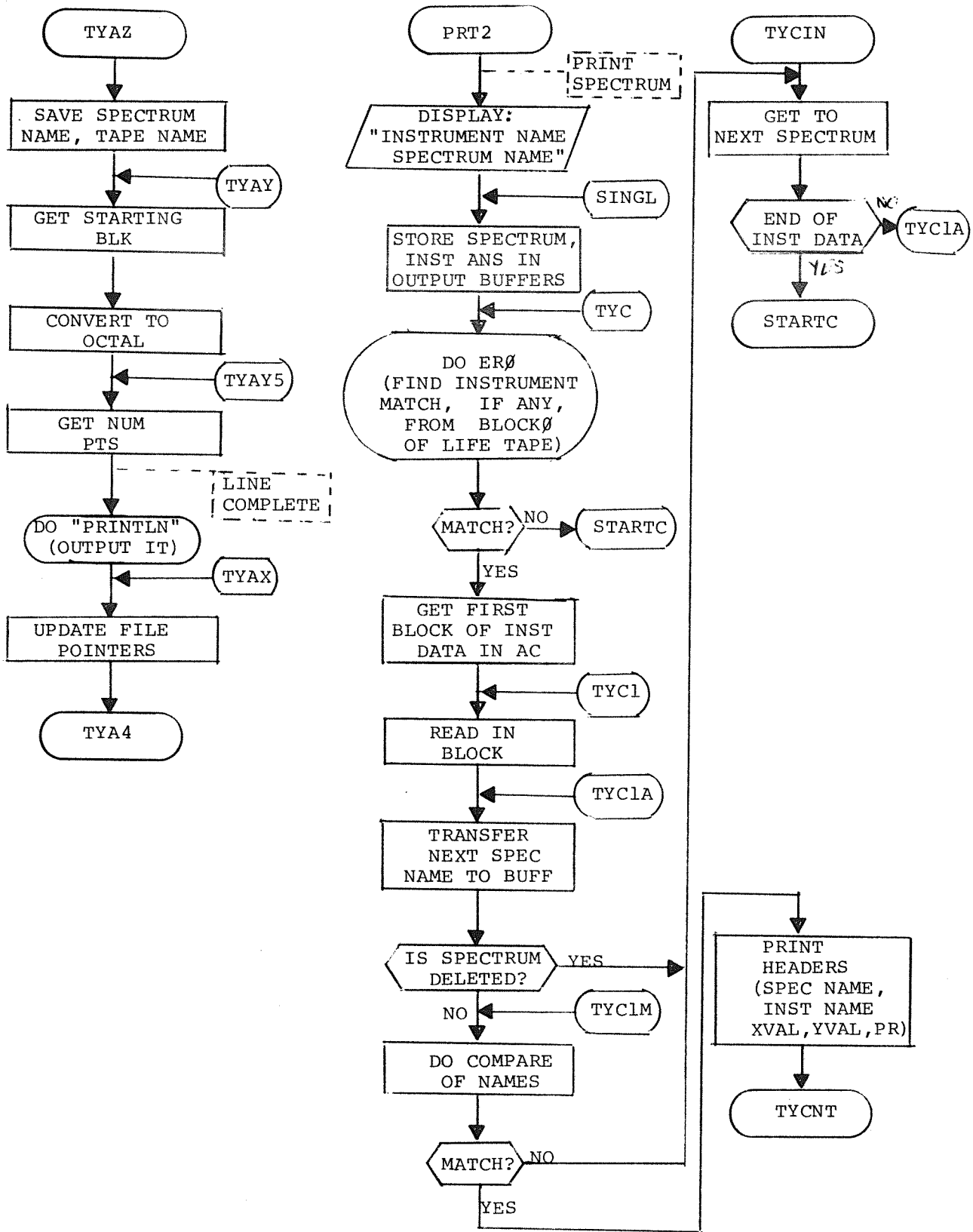

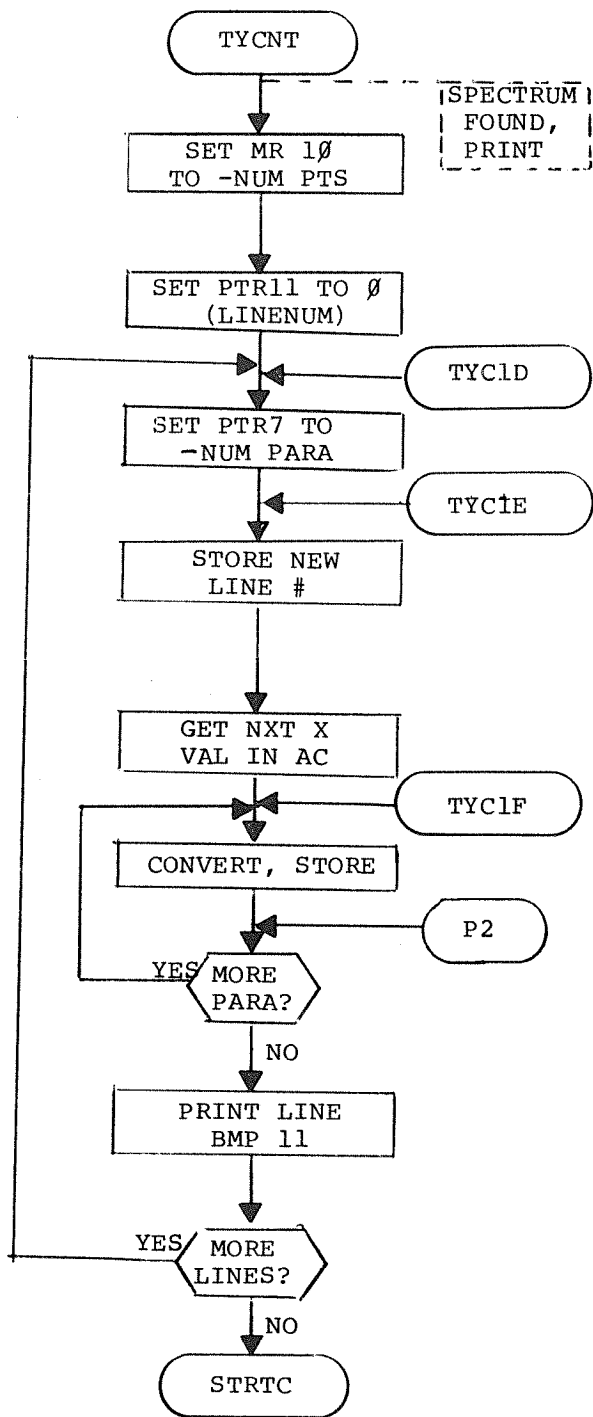

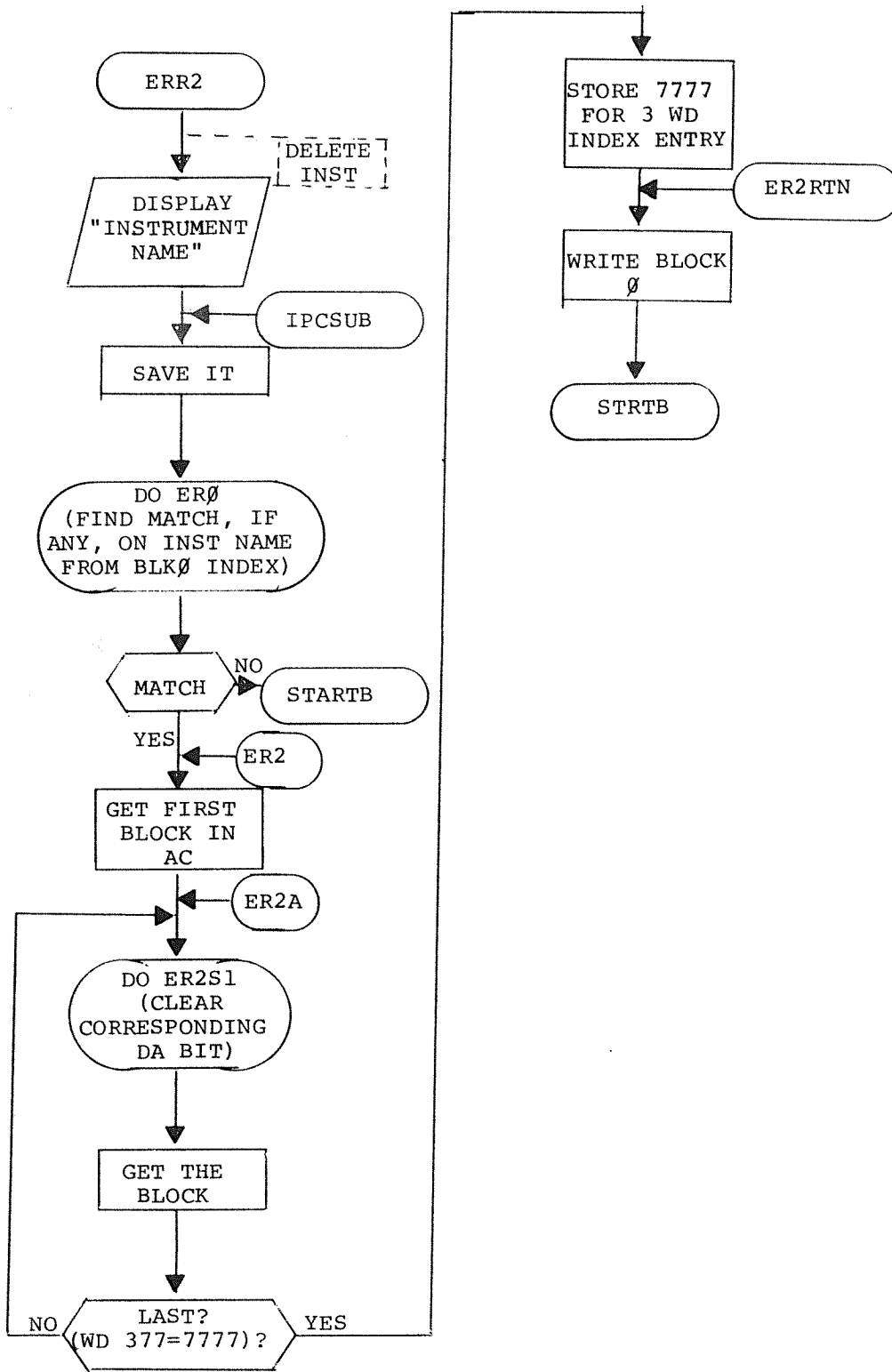

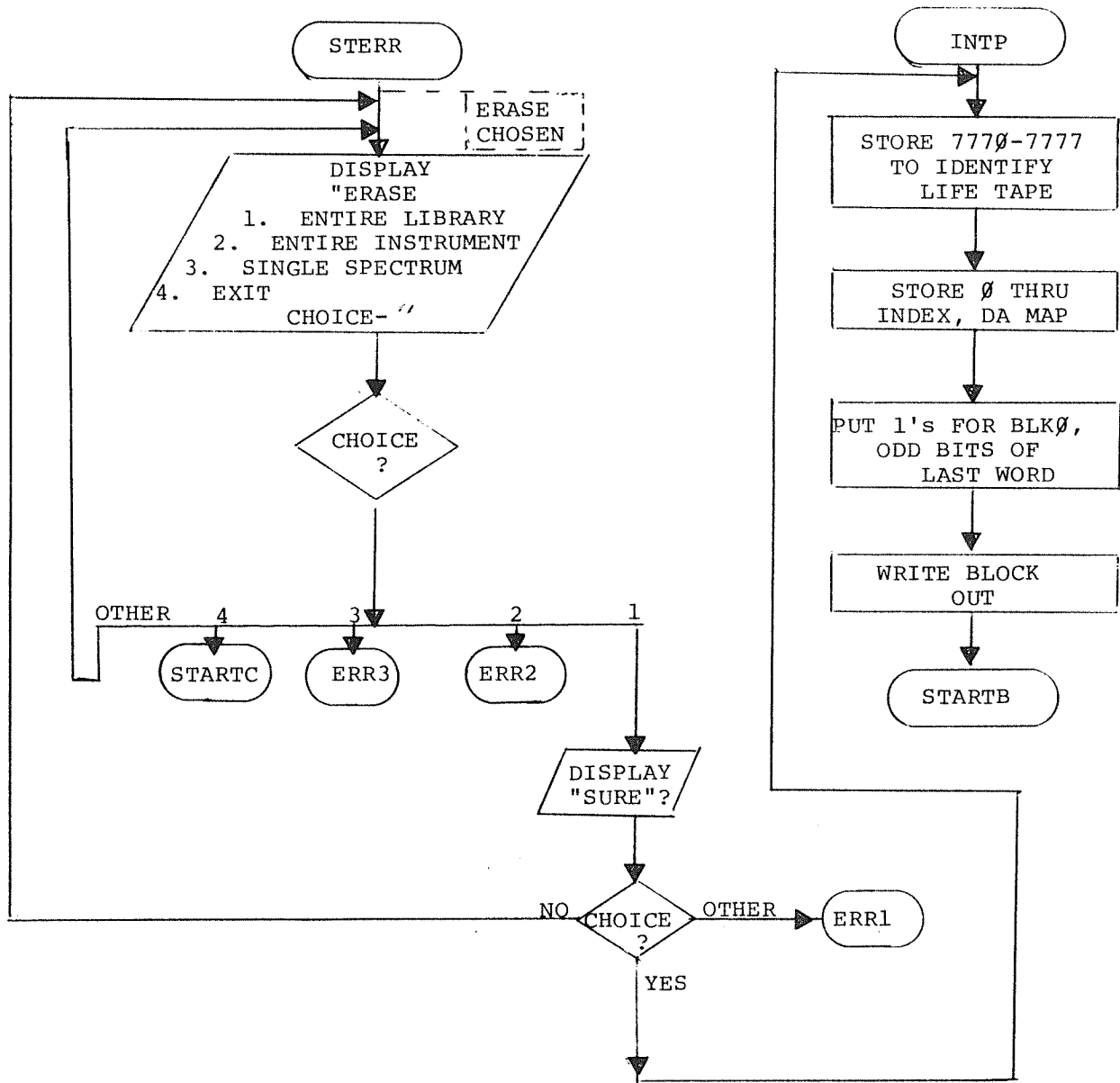

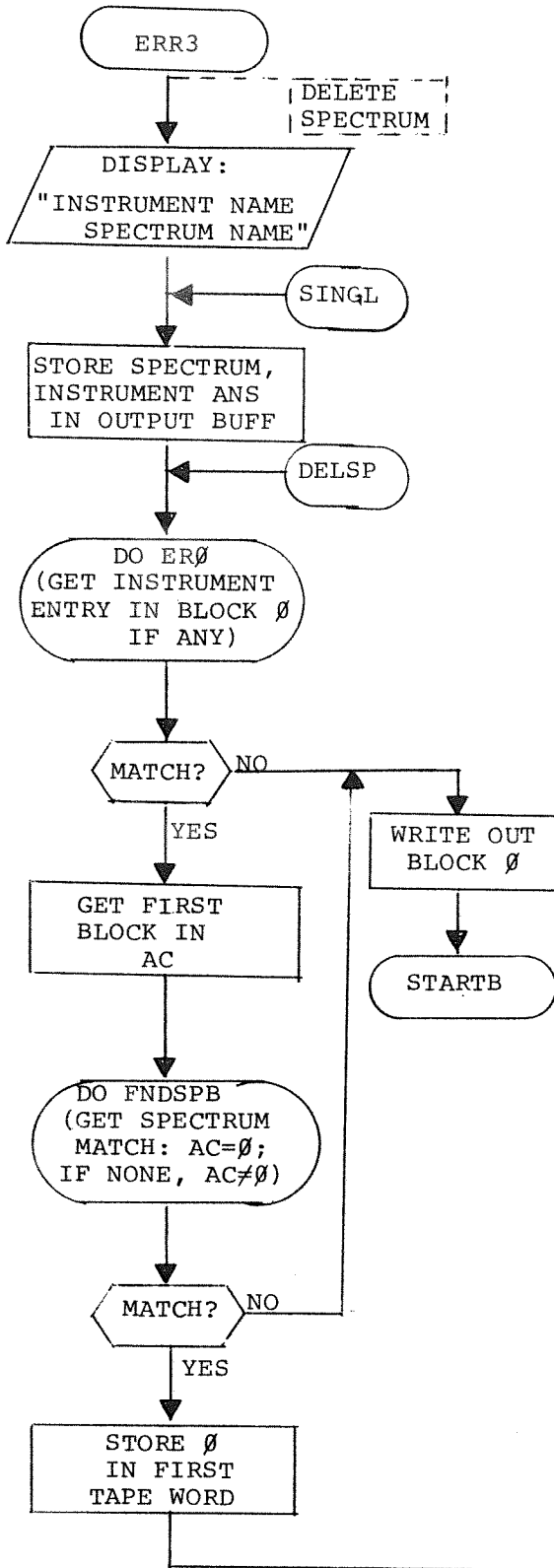

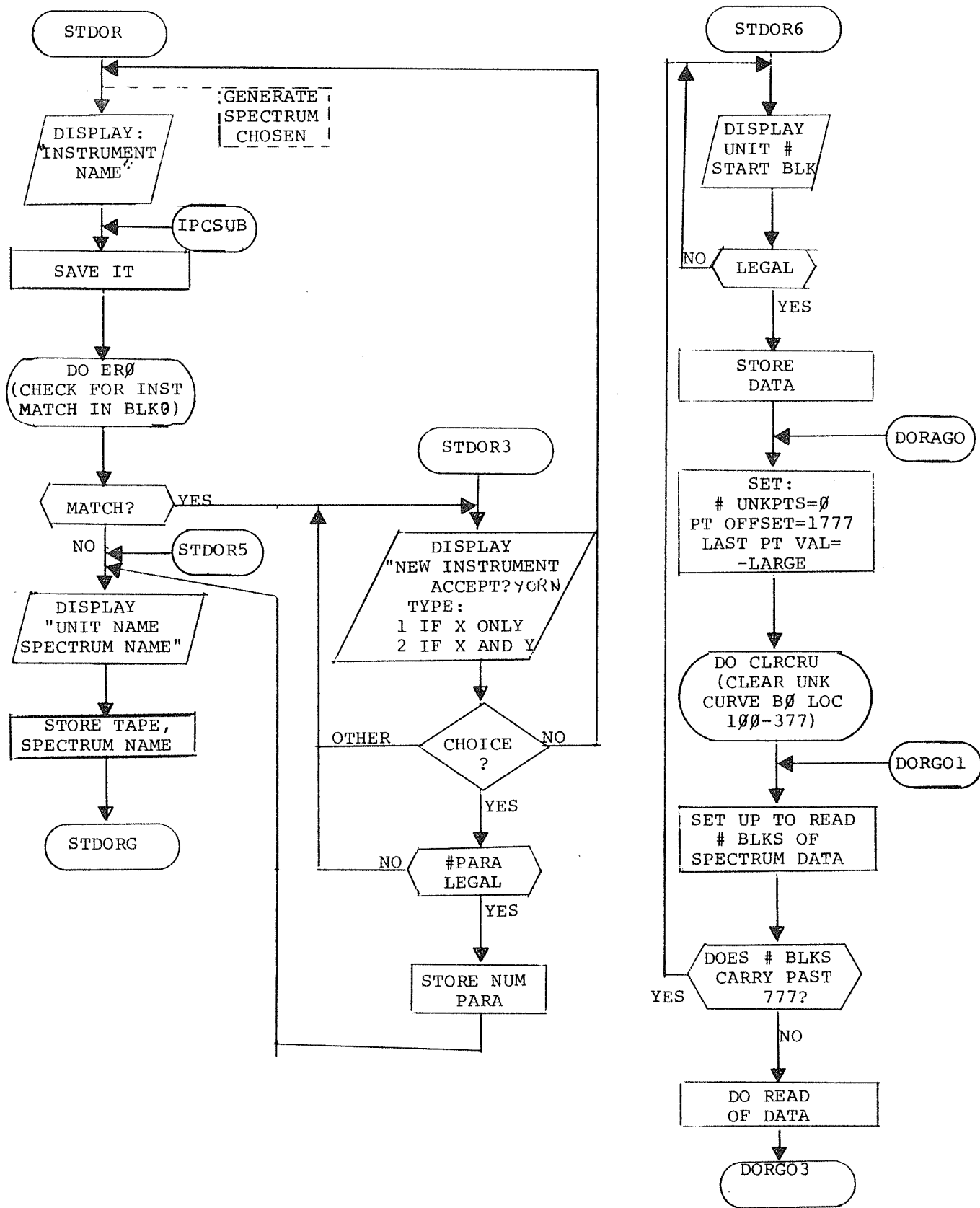

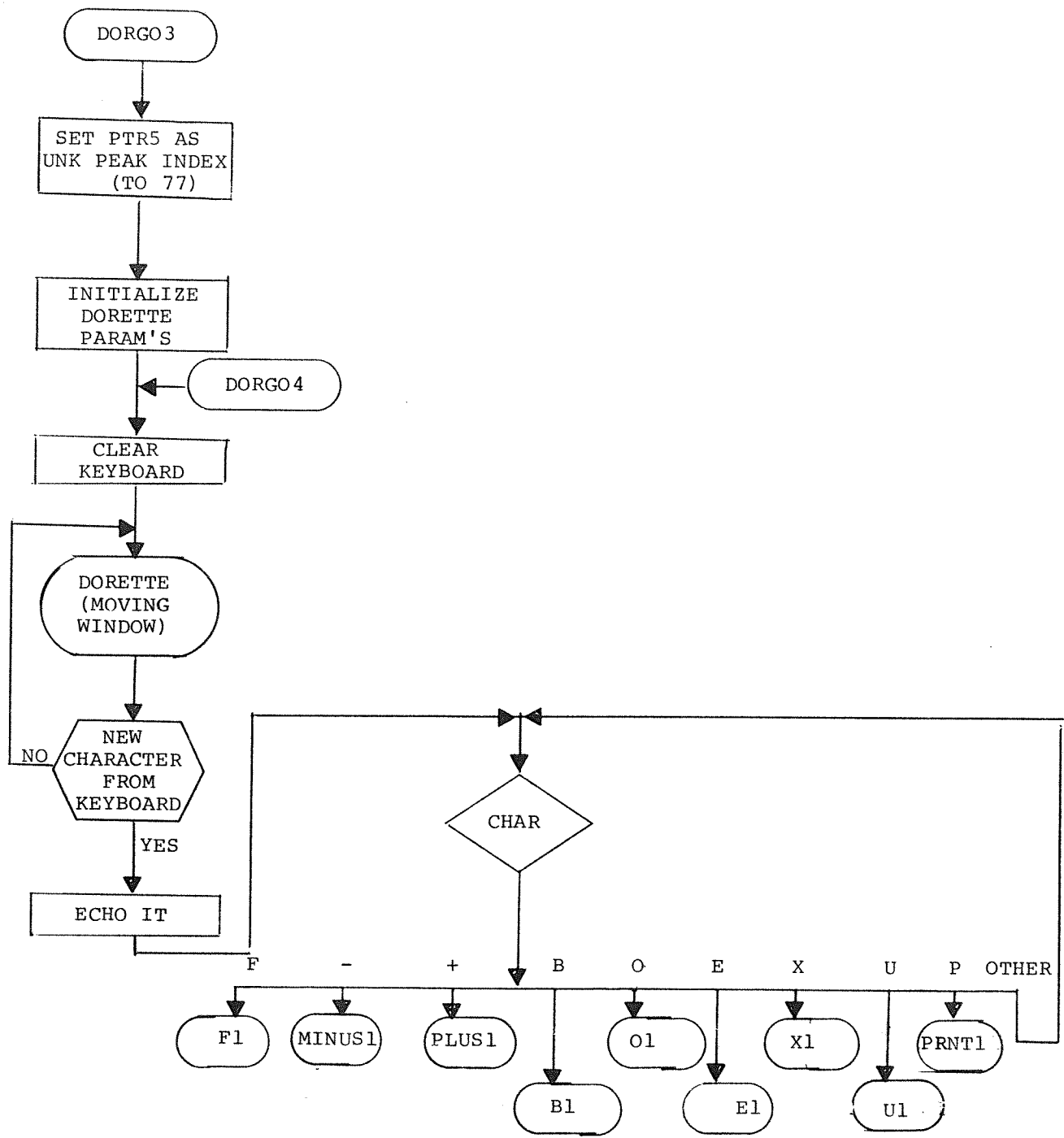

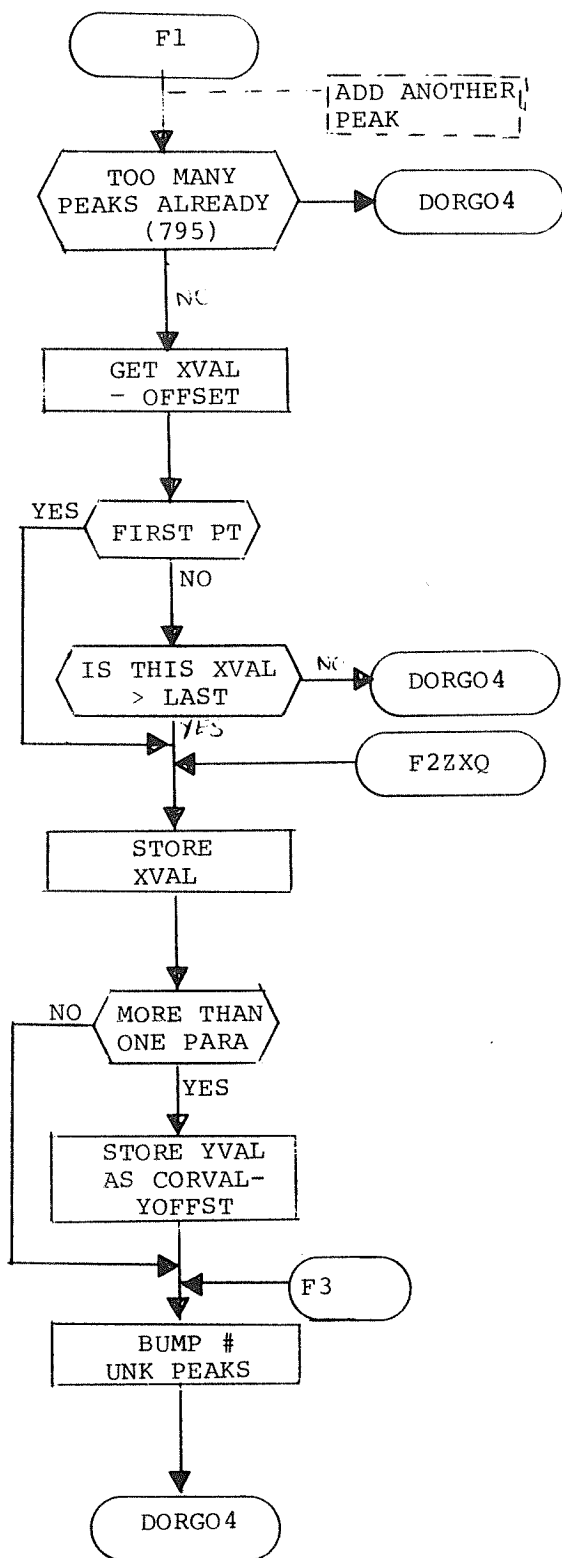

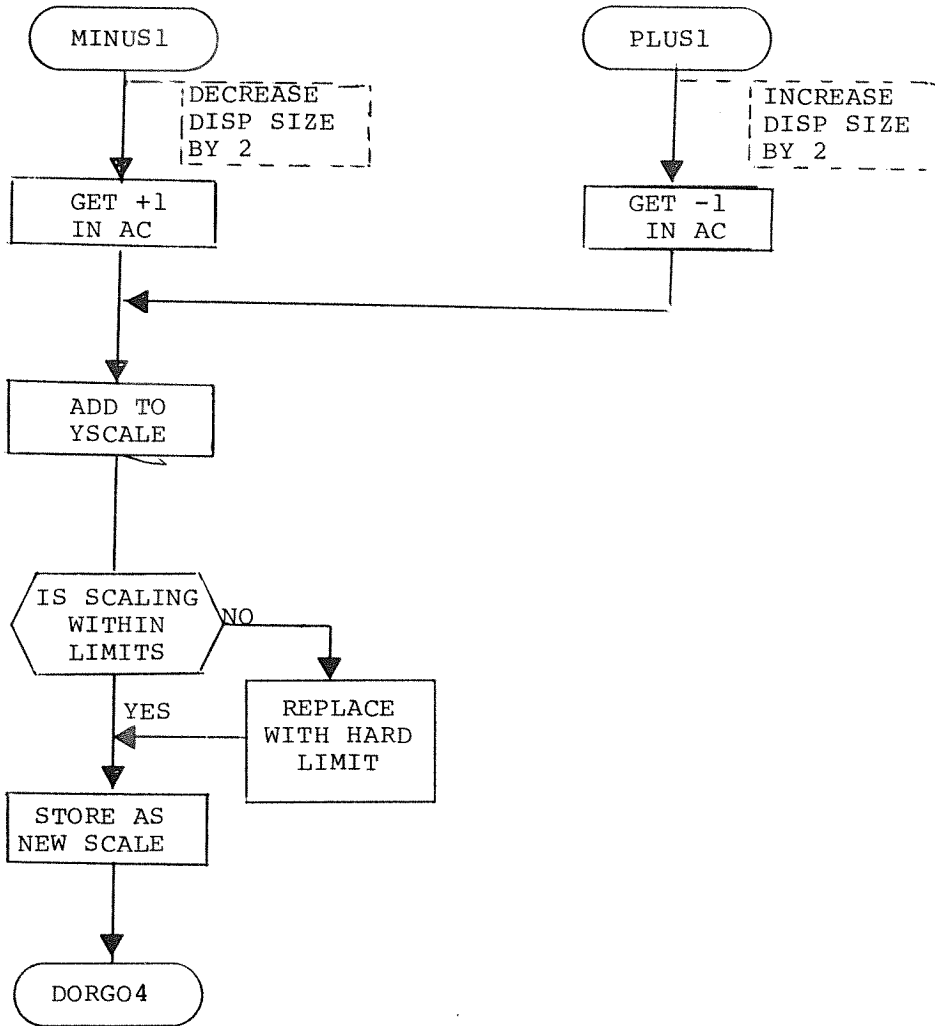

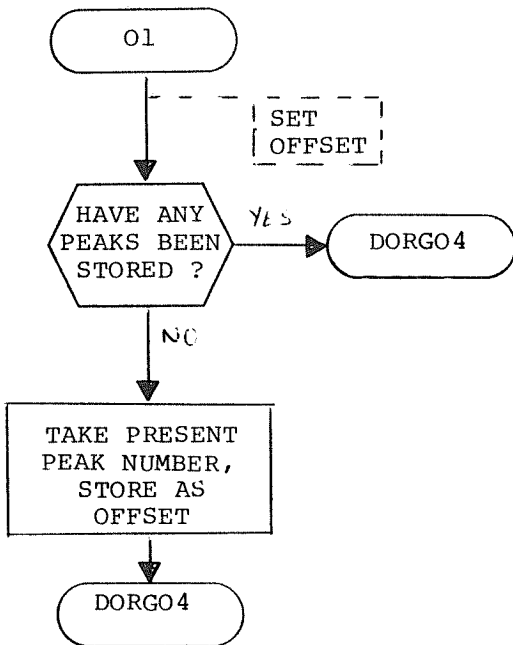
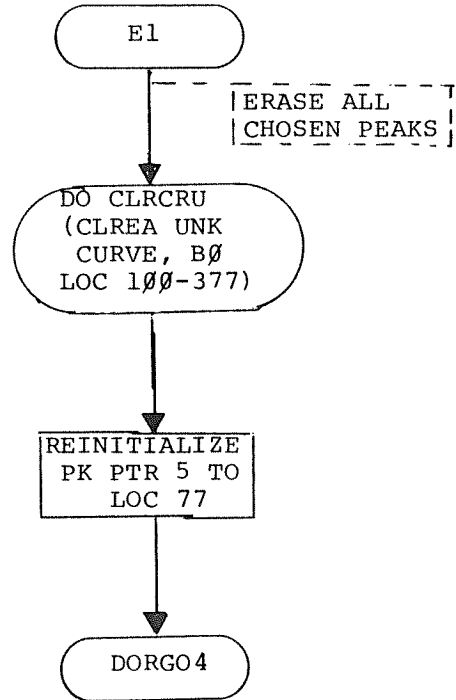
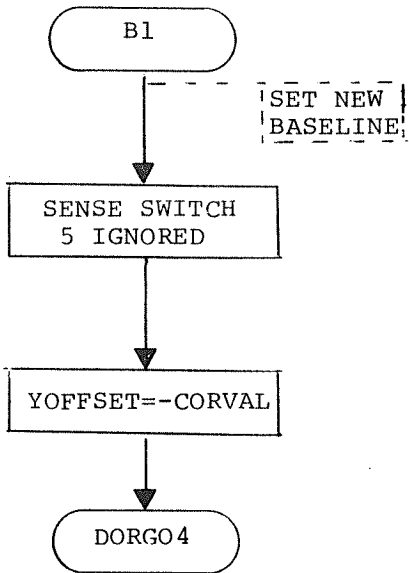

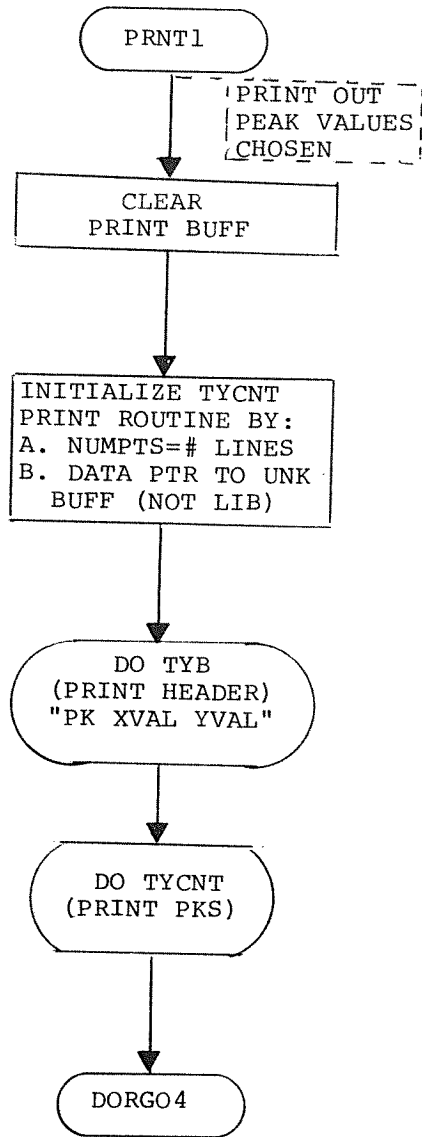

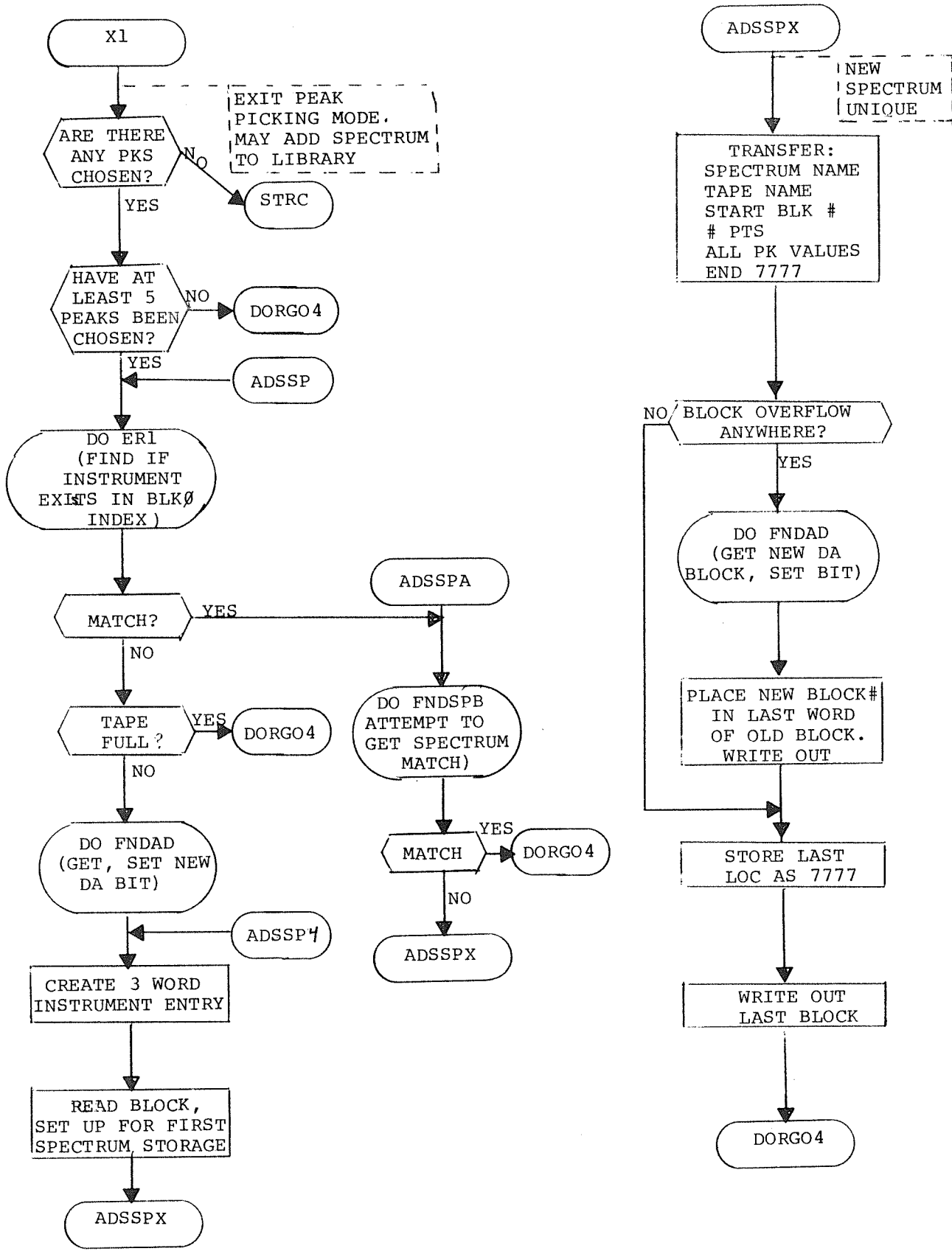

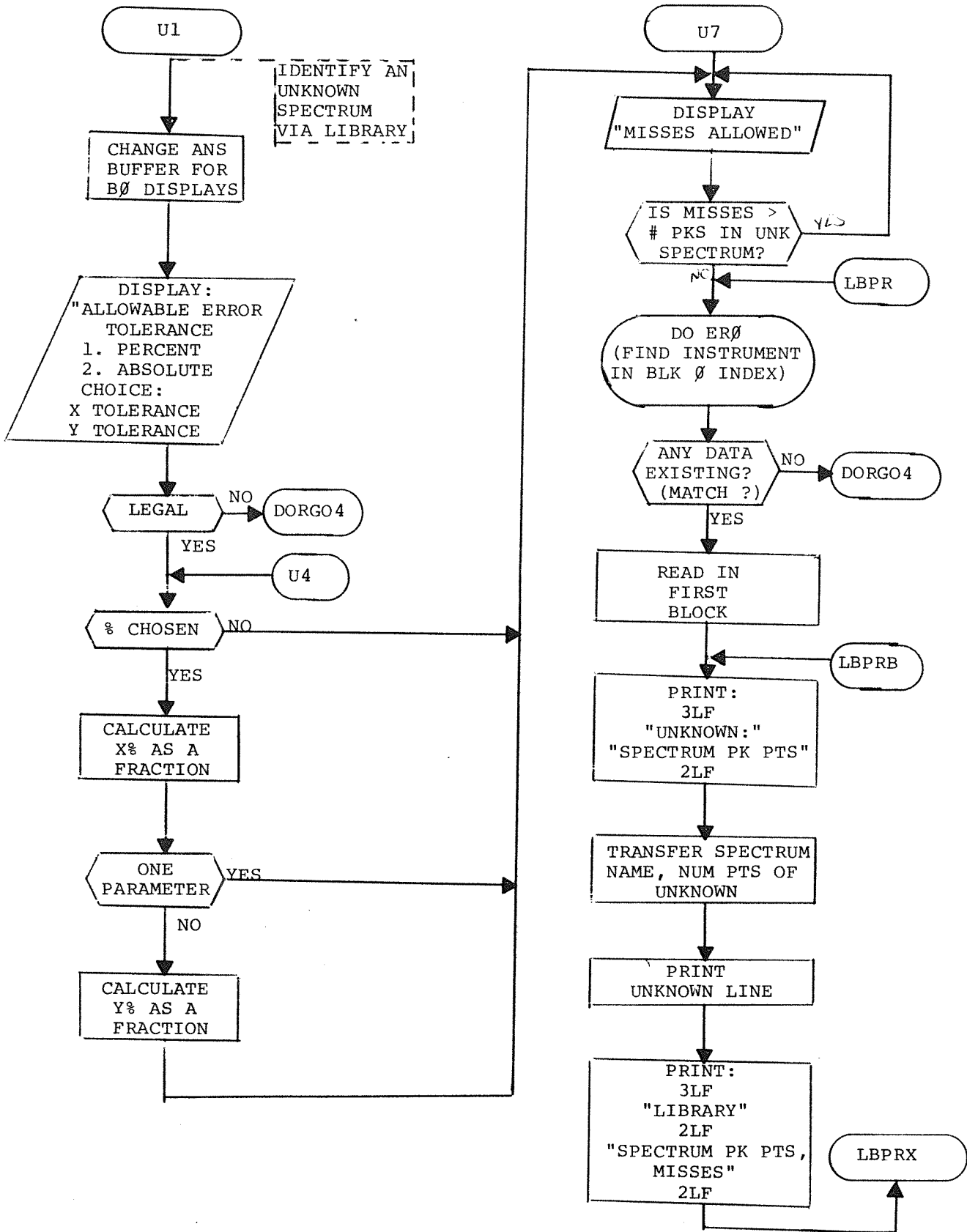

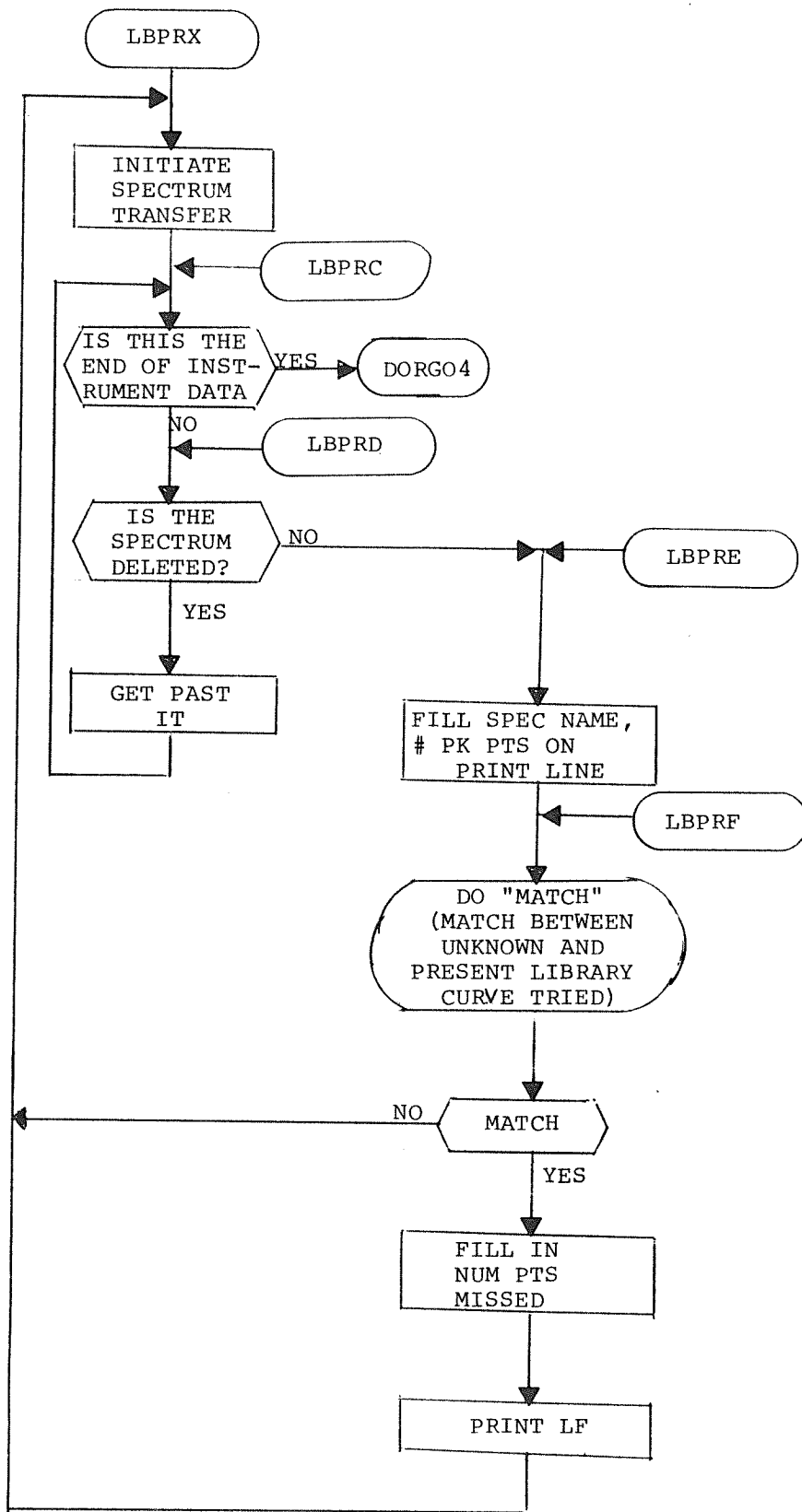

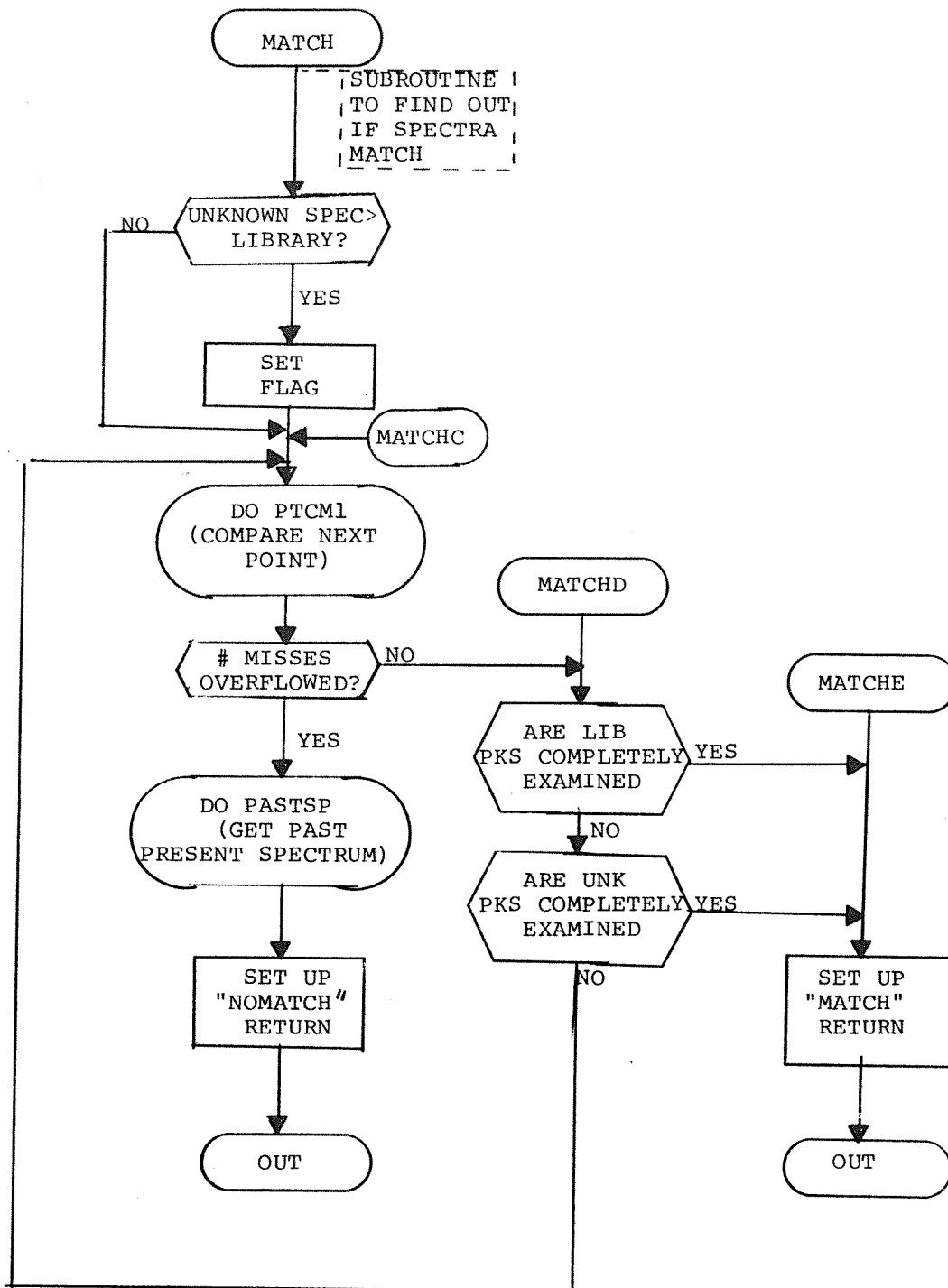

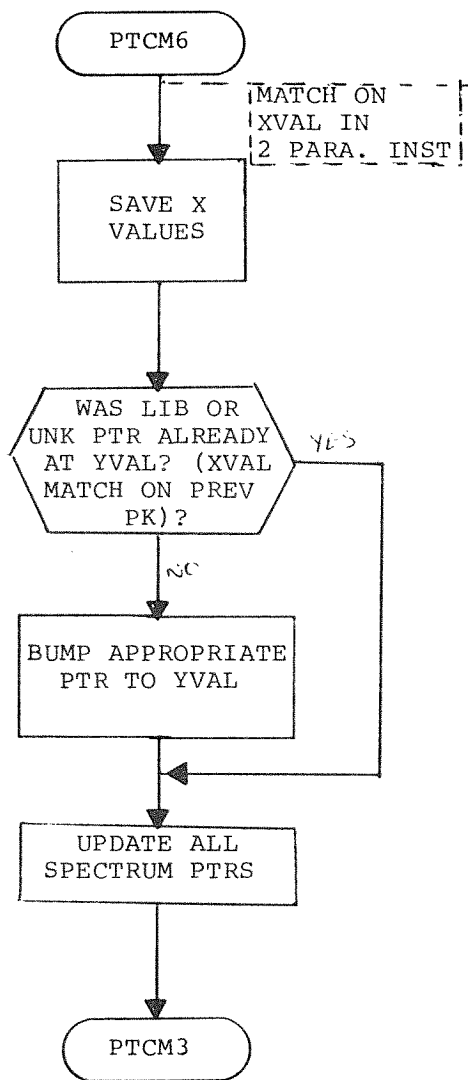

INDEX

Absolute Error 10
Assembly Instructions 16
A/D Knobs 5, 6

Baseline Correction 7

Commands 6
Core Address 6
CTRL/R 3
Cursor 5, 6

DIAL-MS 1
Disks 1
Display Window 5
Double Display Size 6

Erase 15
Error Messages 16
Error Tolerance 10
Exit 9

Fix Point Values 7
Flowcharts of Displayed Messages A-1
Functions 2

Generating New Spectra 3

Halve Display Size 6
Hardware Requirements 1

Identify Unknown Spectrum 10
Index 13
Initialization 1
Instrument Definition 3
Instrument Deletion 15
Introduction 1

Library 2, 10, 13, 15

Line Feed 2, 4
Loading Procedure 1

Misses Accepted 11
Modes of Operation 2

Non-matches 11

Octal Words 6
Offset 7
Operating Procedures 1

Percent Error 10
Print 13
Print Peak Points 9

Raw Data 4

Spectrum Definition 4
Spectrum Deletion 15
Spectrum Display 5
Spectrum Matching 11
Spectrum Printout 14
Spectrum Search 10

Wrap-around 5

```

0000      *20
0001      /LIFE B0
0002      /REAL TIME LIBRARY LOOKUP OF UNKNOWN SPECTRA
0003      /COPYRIGHT 1970; DIGITAL EQUIPMENT CORPORATION
0004      /
0005      /
0006      /
0007      /RELEASED OCTOBER 1970
0010      /
0011      /
0012      /WRITTEN BY RON KLEINMAN
0013      /
0014      /
0015      /PTR BUFF IN THIS BANK
0016      SEGMENT 0
0017      *20
0020      /CONSTANTS, TEMP STORAGE, REF FLGS ETC.
0021      0020 0000 PARDAT, 0 /DATA TAPE UNIT = SET BY DISP
0022      0021 0004 4 /CORE LOCATION - B1 = CNST
0023      0022 0000 0 /STARTING BLK NUM = SET BY DISP
0024      0023 0000 0 /NUM BLKS = SET BY DORETTE PROC
0025      0024 0000 NUMPT0, 0 /NUM PTS, SET BY DISP. - LEGALITY >200, <6000
0026      0025 1777 OFFSET, 1777 /ALSO TEMP FOR PAST SPECTRUM
0027      0026 0000 BASLIN, 0
0030      0027 0000 NUMPRA, 0 /PARA IN CURVES = NOW LEGALLY 1 OR 2
0031      0030 0000 TLRNCE, 0 /FOR PARA 1,2,3 RESPECTIVELY IF ABSOLUTE
0032      0031 0000 0
0033      0032 0000 0
0034      0033 0000 MISSES, 0 /NUM MISSES ALLOWED
0035      0034 0000 PTSLIB, 0 /NUM PTS IN LIBRARY TOTAL
0036      0035 0000 PTSUNK, 0 /NUM PTS IN UNKNOWN = RUNNING TOTAL, SET PRIOR MATCH
0037      0036 0000 COMMIS, 0 /NUM MISSES FOR THIS SPECTRUM
0040      0037 0000 PTSCVD, 0 /NUM PTS COVERED IN MATCH ROUT
0041      0040 0024 PRCNT1, 24 /ONE PERCENT - CONSTANT
0042      0041 3700 3700
0043      0042 4040 SPSPA, 4040
0044      0043 0012 P12, 12
0045      0044 0000 UNKVAL, 0
0046      0045 0000 BUMPR, 0 /SET=NO BUMP PTR 14,UNK
0047      0046 0000 BUMPR1, 0 /SET=NO BUMP PTR 16,LIB
0050      0047 0000 XWORD, 0
0051      0050 0000 XWORD1, 0
0052      /ABOVE 3 FROM MATCH ROUTINE
0053      0051 0000 FLAGWD, 0 /FLAG WORD
0054      /BIT0=1, UNKNOWN SPECTRA>LIBRARY SPECTRA PTWISE
0055      /BIT1=1, PERCENT TOLERANCE,
0056      0052 0000 PRCT1, 0 /FOR PARA 1,2,3, RESPECTIVELY IF PERCENT
0057      0053 0000 0
0060      0054 0000 PRCT2, 0
0061      0055 0000 0
0062      0056 0000 PRCT3, 0
0063      0057 0000 0
0064      0060 0000 XNMBUF, 0 /FOR MULT
0065      0061 0000 0
0066      0062 0000 XNMTMP, 0 /IN PTFAIL ROUT ALSO
0067      /NEG IF LIB XVAL>UNK XVAL
0070      0063 3777 P3777, 3777
0071      0064 7774 QRD, READ
0072      0065 7775 QWT, WRITE

```

```

0073          *400
0074      0400  0000  BUFB0,  0      /10 WD BUFFER FOR TEXT STRINGS
0075          *415
0076          /CALL SUBROUTINE IN B6 FROM B0
0077      0415  0261  B6FRB0,  ROL I 1
0100      0416  0301          ROR 1      /SAVE BIT 0 IN LINC
0101      0417  0353          SCR 13     /SAVE BITS 1-11 IN MQ
0102      0420  1000          LOA
0103      0421  0000          0
0104      0422  1040          STA
0105      0423  0016          16
0106      0424  1560          BCL 1
0107      0425  6000          6000
0110      0426  4015          STC 15
0111      0427  0640          LDF 0
0112      0430  1015          LDA 15  /GET CONTENTS OF LOC AFTER CALL TO B6FRB0
0113      0431  0236          XSK I 16
0114      0432  0606          LIF 6
0115      0433  6020          JMP B6CALL
0116      0434  0647          LDF 7  /RETURN, VALUE IN AC IS OUTCOME
0117      0435  6016          JMP 16
0120          /SUBROUTINE TO COMPARE UNKNOWN TO LIBRARY
0121          /ASSUMES TOL, MISSES, NUM PTS IN BOTH SET
0122          /WILL HAVE BUMP IF MATCH, RET IF NO MATCH,
0123          /PTRS 7-14, 15,16 IN B6SUB CALLER
0124          /AC CONTAINS POINTS IN LIB, FLAGWD CORRECTLY SET
0125          /PTR 16 AT PTS LIB, ENDS AT LAST LOC IN DATA
0126          PMODE
0127      0436  1051  MATCHF,  TAD Z FLAGWD
0130      0437  0063          AND Z P3777
0131      0440  5257          JMP MATCHB=1
0132          LMODE
0133      0441  4034  MATCH,   STC PTSLIB
0134      0442  4036          STC COMMIS
0135      0443  2000          ADD 0
0136      0444  4017          STC 17  /SAVE RET
0137      0445  4037          STC PTSCVD
0140          /FIND WHICH SPECTRUM HAS MORE POINT = 8 CODE
0141      0446  0002          PDP
0142          PMODE
0143      0447  1035          TAD Z PTSUNK
0144      0450  7140          CMA CLL
0145      0451  1034          TAD Z PTSLIB  /LIB-UNK
0146      0452  7700          SMA CLA
0147      0453  5236          JMP MATCHF
0150      0454  1051          TAD Z FLAGWD  /IF LIB<UNK
0151      0455  7004          RAL
0152      0456  7130          STL RAR      /SET BIT 0
0153      0457  3051          DCA Z FLAGWD
0154          /LIB HAS LESS PTS
0155      0460  1034  MATCHB,  TAD Z PTSLIB
0156      0461  7040          CMA
0157      0462  3012          DCA 12  /PTR 12 HAS - NUM LIB PTS
0160      0463  1035          TAD Z PTSUNK
0161      0464  7040          CMA
0162      0465  3013          DCA 13  /PTR 13 HAS - NUM UNK PTS
0163      0466  6141          LINC
0164          LMODE
0165          /PTR 16 VIA TRANSB IS AT START OF LIB DATA
0166      0467  0074          SET I 14
0167      0470  0077          77  /SET PTR 14 TO START OF UNKNOWN DATA
0170          /COMPARE NEXT POINT
0171      0471  6557  MATCHC,  JMP PTM1

```

0172			/CHECK MISSES
0173	0472	2033	ADD MISSES
0174	0473	0017	COM
0175	0474	2036	ADD COMMIS
0176	0475	0451	APD
0177	0476	6501	JMP MATCHD
0200			/NUM MISSES TOO HIGH, NOMATCH
0201	0477	6535	MTHRT, JMP PASTSP /GET PAST SPECTRUM
0202	0500	6017	JMP 17 /EXIT
0203			/GO ON, CHECK MORE PTS
0204	0501	0212	MATCHD, XSK 12
0205	0502	6504	JMP ,+2
0206	0503	6506	JMP MATCHE
0207	0504	0213	XSK 13
0210	0505	6471	JMP MATCHC
0211			/OVER MATCH FOUND, NUM MISSES IN COMMIS, BUMP RET
0212	0506	0237	MATCHE, XSK I 17
0213	0507	6477	JMP MTHRT
0214	0510	1000	PTCM6, LDA
0215	0511	0044	UNKVAL
0216	0512	4050	STC XWORD1
0217	0513	2025	ADD OFFSET
0220	0514	4047	STC XWORD
0221			/XVALS SAVED, NOW BUMP PTRS, MAYBE
0222	0515	7005	JMP PTZA
0223	0516	7014	JMP PTZA1 /ONLY BUMP IF PTR AT XVAL
0224			/MUST ALSO RESTORE BOTH Y VALS
0225			/JUST IN CASE 1 NOT BUMPED
0226	0517	0646	LDF 6
0227	0520	1000	LDA
0230	0521	2016	2016
0231	0522	4001	STC 1
0232	0523	0647	LDF 7
0233	0524	1001	LDA 1
0234	0525	4025	STC OFFSET
0235	0526	1014	LDA 14
0236	0527	4044	STC UNKVAL
0237	0530	0017	COM
0240	0531	4045	STC BUMPR
0241	0532	0017	COM
0242	0533	4046	STC BUMPR1
0243	0534	6571	JMP PTCM3
0244			/GET PAST SPECTRUM = SUBSUB
0245			/PTR 16 IN MIDDLE AT (PTSLIB = PTSCUD)XPARA
0246			/SET PTR 15 B6 TO = THIS, THEN DO SUB ADV16
0247	0535	1000	PASTSP, LDA
0250	0536	0000	0
0251	0537	4545	STC PASTRT
0252	0540	2027	ADD NUMPRA
0253	0541	0017	COM
0254	0542	4006	STC 6 /-NUM PAR IN 6
0255	0543	2012	ADD 12
0256	0544	0470	AZE I
0257	0545	6000	PASTRT, RETURN /IF NO POINTS LEFT, RETURN(16 AT LAST SPEC PT), AC CL
0260	0546	0017	COM
0261	0547	4025	STC OFFSET /STORE DIFF IN TEMP
0262	0550	2025	PASTS1, ADD OFFSET
0263	0551	0226	XSK I 6
0264	0552	6550	JMP PASTS1
0265	0553	0017	COM
0266			/MOVE LOC IN AC. PTR16 AT LAST SPEC PT
0267	0554	6415	JMP B6FRB0
0270	0555	6626	JMP MV16 /MOVE 16 TO SAFETY

```

0271      05 56 65 45      JMP PASTRT      /EXIT
0272      /SUBROUTINE TO COMPARE POINTS
0273      /IF MATCH, OK, NO, BUMP COMMIS, CLEAR AC
0274      05 57 10 00  PTCM1, LDA
0275      05 60 00 00      0
0276      05 61 46 30      STC PTCMRT
0277      05 62 40 45      STC BUMPR
0300      05 63 40 46      STC BUMPR1
0301      /SET IS PTR AT Y VAL FLAGS
0302      05 64 67 00      JMP PTFALC      /SET PTR6 TO - PARA
0303      05 65 70 02  PTCM2, JMP PTR14B
0304      05 66 64 15      JMP B6FRB0      /GET NEXT LIB PARAMETER IN OFFSET
0305      05 67 62 44      JMP TRANSB      /GET TO NEXT UNK PTR IN UNKVAL
0306      05 70 40 25      STC OFFSET
0307      05 71 10 20  PTCM3, LDA I
0310      05 72 00 30      TLRNCE /ABSOLUTE TOLERANCE LOCATION
0311      05 73 20 27      ADD NUMPRA
0312      05 74 20 06      ADD 6
0313      05 75 40 07      STC 7 /IN PTR 7
0314      05 76 20 51      ADD FLAGWD
0315      05 77 02 41      ROL 1
0316      06 00 04 51      APO
0317      06 01 67 53      JMP PTCMA      /IF PERCENT, GET CONVERTED TOL WD
0320      /ASSUME TOL WD SET, IN PTR7
0321      06 02 10 07  PTCM4, LDA 7 /CHECK UPPER LIMIT
0322      06 03 20 44      ADD UNKVAL      /UNK+TOL>=LIB,OK
0323      06 04 00 17      COM
0324      06 05 20 25      ADD OFFSET
0325      06 06 00 17      COM
0326      06 07 04 51      APO
0327      06 10 66 31      JMP PTFAIL      /FAILURE, UPPER, AC-
0330      /CHECK LOWER LIMIT
0331      06 11 10 07      LDA 7 /UNK=TOL<=LIB, OK
0332      06 12 20 25      ADD OFFSET
0333      06 13 00 17      COM
0334      06 14 20 44      ADD UNKVAL
0335      06 15 04 71      APO I
0336      06 16 66 31      JMP PTFAIL      /FAILURE LOWER, AC+
0337      /SUCCESS FOR THIS PARAMETER
0340      06 17 02 26      XSK I 6
0341      06 20 65 10      JMP PTCM6      /GET NEXT, SAVE LIB X VAL
0342      /POINT CHECKS
0343      06 21 10 20  PTCM5, LDA I /BUMP PTS CVD
0344      06 22 00 01  PONE, 1
0345      06 23 20 37      ADD PTSCVD
0346      06 24 40 37      STC PTSCVD
0347      06 25 10 32      LDA I 12
0350      06 26 10 33      LDA I 13
0351      /BUMP BOTH PT COUNTS
0352      06 27 00 11      CLR
0353      06 30 60 00  PTCMRT, RETURN /EXIT
0354      /FAILURE
0355      06 31 40 62  PTFAIL, STC XNMTMP
0356      06 32 20 06      ADD 6 /IS THIS THE FIRST PARAMETER
0357      06 33 20 27      ADD NUMPRA
0360      06 34 04 50      AZE
0361      06 35 67 70      JMP PTFALP      /NO, TRY TRY AGAIN
0362      /YES, DOES THE CURVE WITH LESS POINTS HAVE THE LESSER VALUE
0363      /IF YES, THAN THIS IS A FAILURE, BUMP NUM MISSES
0364      /IF NO, BUMP CURVE WITH GREATER POINTS, TRY AGAIN
0365      /FLAGWD NEG IF UNK HAS MORE PTS
0366      /XNMTMP NEG IF LIB HAS GREATER VALUE
0367      06 36 20 62  PTFAQ, ADD XNMTMP

```

0370	0637	1640	BCO	
0371	0640	0051	FLAGWD	/EXCLUSIVE OR IF NEG, EITHER LIB OR UNK HAS
0372	0641	0451	APD	/LESS VALUE AND LESS PTS, ERROR
0373	0642	6743	JMP PTFALB	/BUMP ERROR
0374				/BUMP PAST POINT IN SPEC WITH LESSER VALUE, MAY NOT BE ERROR
0375	0643	1000	LDA	
0376	0644	0062	XNMTMP	
0377	0645	0451	APD	
0400	0646	6705	JMP PTFALH	
0401				/LIB HAS LESSER VALUE
0402	0647	0226	PTFALD, XSK I 6	
0403	0650	6652	JMP ,+2	
0404	0651	6654	JMP PTFALH	
0405	0652	7014	JMP PTZA1	/MAYBE BUMP LIB PTR
0406	0653	6647	JMP PTFALD	
0407	0654	6700	PTFALE, JMP PTFALC	/RESTORE PTR6 TO NUM PARA
0410	0655	4046	STC BUMPR1	/RESET LIB BMP FLAG
0411	0656	0232	XSK I 12	
0412	0657	0456	SKP	
0413	0660	6665	JMP YQ1	/LIB OVER
0414	0661	6415	JMP B6FRB0	
0415	0662	6244	JMP TRANSB	
0416	0663	4025	STC OFFSET	
0417			/NEW LIBX VAL SAVED	
0420	0664	6571	JMP PTCM3	/PROCESS MORE OR
0421	0665	0072	YQ1, SET I 12	/OVER, RESET PTR TO SKIP, BUMP ERROR
0422	0666	7776	PM1, 7776	
0423	0667	2051	ADD FLAGWD	
0424	0670	0451	APD	/IF UNK SMALLER
0425	0671	6621	JMP PTCM5	
0426	0672	1000	LDA	
0427	0673	0013	13	
0430			/ALL REMAINING UNK PTS ARE ERRORS	
0431	0674	0017	Z6, COM	
0432	0675	2036	ADD COMMIS	
0433	0676	4036	STC COMMIS	
0434	0677	6621	JMP PTCM5	
0435			/RESTORE PTR 6	
0436	0700	1000	PTFALC, LDA	
0437	0701	0027	NUMPRA	
0440	0702	0017	COM	
0441	0703	4006	STC 6	
0442	0704	6000	JMP 0	
0443			/UNK HAS LESSER VALUE	
0444	0705	0226	PTFALH, XSK I 6	
0445	0706	6710	JMP ,+2	
0446	0707	6712	JMP PTFALJ	/BUMP 1 WD FOR EACH PTR
0447	0710	7005	JMP PTZA	/GET NEXT UNK LOC, MAYBE
0450	0711	6705	JMP PTFALH	
0451	0712	6700	PTFALJ, JMP PTFALC	/RESTORE PTR6 TO NUM PARA
0452	0713	4045	STC BUMPR	/RESET FLG
0453	0714	1034	LDA I 14	
0454			/SAVE NEW UNK VAL-FRST PARA OF NXT PT	
0455	0715	4044	STC UNKVAL	
0456	0716	0233	XSK I 13	/CURVE OVER?
0457	0717	6571	JMP PTCM3	/NO, JUMP NEW COMPARE
0460			/YES, MOVE LIB PTR TO Y PARA	
0461			/IF NOT ALREADY THERE	
0462			/AND A 2 PARA INST	
0463	0720	2027	PTFALK, ADD NUMPRA	
0464	0721	1460	SAE I	
0465	0722	0002	2	
0466	0723	6732	JMP PTFALL	/IF 1 PARA,OUT

```

0467      0724 1000      LDA
0470      0725 0046      BUMPR1
0471      0726 0451      APO
0472      0727 6732      JMP PTFALL      /IF LIB ON Y,OUT
0473      0730 6415      JMP B6FRB0
0474      0731 6244      JMP TRANSB      /ELSE MOVE LIB
0475      0732 0011      PTFALL, CLR
0476      0733 0073      SET I 13
0477      0734 7776      7776
0500      0735 2051      ADD FLAGWD
0501      0736 0471      APO I      /IF LIB SMALLER
0502      0737 6621      JMP PTCM5
0503      0740 1000      LDA
0504      0741 0012      12
0505      /ALL REMAINING LIB PTS ARE ERRORS
0506      0742 6674      JMP Z6
0507      /FAILURE, AT LAST PARA
0510      0743 1020      PTFALB, LDA I /INCREMENT MISSES, EXIT
0511      0744 0001      1
0512      0745 2036      ADD COMMIS
0513      0746 4036      STC COMMIS
0514      0747 2622      ADD PONE
0515      0750 2037      ADD PTSCVD
0516      0751 4037      STC PTSCVD
0517      0752 6000      JMP 0
0520      /CONVERT PERCENT TO ABSOLUTE TOL FOR THIS PT
0521      /LIB PT IN OFFSET
0522      0753 1020      PTCMA, LDA I
0523      0754 0052      PRCT1
0524      0755 2027      ADD NUMPRA
0525      0756 2027      ADD NUMPRA
0526      0757 2006      ADD 6
0527      0760 2006      ADD 6
0530      0761 1620      BSE I /PTR 10 HAS SINGLE PREC PARA MULTIPLIER
0531      0762 4000      4000 /4000 FOR FRACTIONAL MUL T
0532      0763 4010      STC 10
0533      0764 2025      ADD OFFSET
0534      0765 1250      MUL 10 /TOLERANCE IS IN AC
0535      0766 1047      STA 7 /STORE IN TOL WD
0536      0767 6000      JMP 0 /JUMP LIMIT CHECKING
0537      /FAILURE ON Y, BMP APPROPRIATE PT
0540      0770 1000      PTFALP, LDA
0541      0771 0047      XWORD
0542      0772 4025      STC OFFSET
0543      0773 2050      ADD XWORD1
0544      0774 4044      STC UNKVAL
0545      /GET XTMP NEG IF LIB X>UNKX
0546      0775 2047      ADD XWORD
0547      0776 0017      COM
0550      0777 2050      ADD XWORD1
0551      1000 4062      STC XNMTMP
0552      1001 6636      JMP PTFAQ      /SAVE X VALS
0553      1002 1034      PTR14B, LDA I 14
0554      1003 4044      STC UNKVAL
0555      1004 6000      JMP 0
0556      /BUMP ONLY UNK PTR MAYBE
0557      1005 1000      PTZA, LDA
0560      1006 0000      0
0561      1007 5013      STC PTZAR
0562      1010 2045      ADD BUMPR
0563      1011 0471      APO I
0564      1012 7002      JMP PTR14B
0565      1013 0000      PTZAR, 0

```

```
0566 /BUMP ONLY LIB PTR, MAYBE
0567 1014 1000 PTZA1, LDA
0570 1015 0000 0
0571 1016 5025 STC PTZAR1
0572 1017 2046 ADD BUMPR1
0573 1020 0451 APO
0574 1021 7025 JMP PTZAR1
0575 1022 6415 JMP B6FRB0
0576 1023 6244 JMP TRANSB
0577 1024 4025 STC OFFSET
0600 1025 0000 PTZAR1, 0
0601 EJECT
=
```

```

0602 /SUBROUTINE TO MULTIPLY NUM IN XNMBUF BY AC, STORE IN PTR 6
0603 XNUM, COM
0604 1026 0017 STC 7 /PTR 7 HAS =
0605 1027 4007 ADD 0
0606 1030 2000 STC XNMRET /SAVE RET
0607 1031 5051 XNUMA, SET 10
0610 1032 0050 6
0611 1033 0006 STA 6
0612 1034 1046 STA I 6 /CLEAR BUFF INIT
0613 1035 1066 /PTR 10 HAS UPPER ORDER, PTR 6 LOWER
0614 XNUMB, LDA 10
0615 1036 1010 ADD XNMBUF
0616 1037 2060 STA 10 /GET UPPER ORDER
0617 1040 1050 CLR
0620 1041 0011 ADD XNMBUF+1
0621 1042 2061 LAM 6
0622 1043 1206 STC XNMTMP /GET LOWER ORDER, CLEAR AC
0623 1044 4062 LAM 10 /GET CARRY IN UPPER ORDER
0624 1045 1210 XSK I 7
0625 1046 0227 JMP XNUMB /IF MORE MULT, DO AGAIN
0626 1047 7036 CLR
0627 1050 0011 XNMRET, RETURN /ELSE OUT
0630 1051 6000 LBDATA, 0
0631 1052 0000 0
0632 1053 0000 /SUB TO PRINT OUT MATCHING LIB SPECS
0633 1054 6441 LBPRF, JMP MATCH /DO CURVES MATCH
0634 1055 7102 JMP LBPRZ /NO MATCH
0635 1056 0646 LDF 6 /MATCH, FILL IN NUM PTS MISS
0636 1057 1020 LDA I
0637 1060 7051 LBDATA+5777
0640 1061 1040 STA
0641 1062 2017 2017 /SET PTR 17 IN B6 DECML ROUT
0642 1063 1000 LDA
0643 1064 0036 COMM IS
0644 1065 6415 JMP B6FRB0
0645 1066 6430 JMP DECML
0646 1067 0644 LDF 4
0647 1070 3053 ADD LBDATA+1
0650 1071 1040 STA
0651 1072 3627 TYAN1C+2000 /STORE MISSES
0652 /LINE COMPLETE, PRINT
0653 1073 1020 LDA I
0654 1074 7603 TYANS+5777
0655 1075 0646 LDF 6
0656 1076 1040 STA
0657 1077 2001 2001 /SET PTR1 IN PRINTOUT
0660 1100 0604 LBPRG, LIF 4
0661 1101 7475 JMP LBPR4 /PRT LN, GET NXT SPEC
0662 1102 0606 LBPRZ, LIF 6
0663 1103 7114 JMP LBPRX /JUST GET NEXT SPEC
0664 EJECT

```

=

```

0665                                /START OF INITIALIZE DORRETTE
0666      1104 0604 DORART, LIF 4 /RETURN TO CHOICE OPT
0667      1105 7135                JMP STRTC
0670      1106 0646 DORAGO, LDF 6
0671      1107 4035                STC PTSUNK
0672      1110 1020                LDA I
0673      1111 1777                1777
0674      1112 4025                STC OFFSET
0675      1113 1020                LDA I
0676      1114 4400                4400
0677      1115 1040                STA
0700      1116 0075                75
0701      1117 1040                STA
0702      1120 0076                76
0703      1121 4077                STC 77 /SET INITIAL UNK VAL TO -LARGE
0704      1122 7124                JMP CLRCRV /CLR UNK CURVE
0705      1123 7137                JMP DORG01
0706      1124 1000 CLRCRV, LDA
0707      1125 0000                0
0710      1126 5136                STC CLRT
0711                                /CLR UNK CURVE LOC 100=377
0712      1127 0061                SET I 1
0713      1130 0077                77
0714      1131 0062                SET I 2
0715      1132 7477                =300
0716      1133 1061 CLRMOR, STA I 1
0717      1134 0222                XSK I 2
0720      1135 7133                JMP CLRMOR
0721      1136 6000 CLRT, RETURN
0722      1137 0063 DORG01, SET I 3
0723      1140 4064                4064
0724                                /READ APPROPRIATE NUM BLKS
0725      1141 1000                LDA
0726      1142 0024                NUMPT0
0727      1143 2666                ADD PM1
0730      1144 0350                SCR 10
0731      1145 2622                ADD PONE
0732                                /SET NUM BLKS>NUM PTS*256
0733      1146 4023                STC PARDAT+3
0734                                /LEGALITY1 - NUMBLKS+STBLKS<777
0735                                /ASSUME NUMPTS<6000
0736      1147 2023                ADD PARDAT+3
0737      1150 2022                ADD PARDAT+2
0740      1151 2666                ADD PM1
0741      1152 1560                BCL I
0742      1153 0777                777
0743      1154 0470                AZE I
0744      1155 7160                JMP .+3
0745                                /ERROR, DO NOT DO READ
0746      1156 0604                LIF 4
0747      1157 7261                JMP STDOR6
0750                                /DO READ
0751      1160 0002                PDP
0752                                PMODE
0753      1161 6201                CDF 0
0754      1162 6212                CIF 10
0755      1163 4464                JMS I QRD
0756      1164 0020                PARDAT
0757      1165 6141                LINC
0760                                LMODE
0761      1166 0646                LDF 6
0762      1167 0065 DORG03, SET I 5
0763      1170 0077                77 /INITIALIZE DATA PTR
=

```

0764	1171	1020	LDA I
0765	1172	1777	1777
0766			/INITIALIZE DORETTE CALL LOCATIONS
0767	1173	2024	ADD NUMPT0
0770	1174	1040	STA
0771	1175	6071	DREND+2000 /END PT
0772	1176	0011	CLR
0773	1177	1040	STA
0774	1200	6072	YOFFST+2000 /OFFSET=0
0775	1201	4035	STC PTSUNK
0776	1202	1020	LDA I
0777	1203	0341	SCR 1
1000	1204	1040	STA /SCALE=1
1001	1205	6073	YSCALE+2000
1002	1206	6415	DORG04, JMP B6FR00
1003	1207	6061	JMP INTORA /INITIALIZE DORA, READ BLKS
1004	1210	0646	PROCMD, LDF 6 /PROCESS COMMAND
1005	1211	5221	STC DORG08
1006	1212	0063	SET I 3 /IS BRT SPOT ON CURVE
1007	1213	4065	4065 /IF NOT ERROR 5
1010	1214	1000	LDA
1011	1215	7773	CURCNT+2000
1012	1216	0451	APO
1013	1217	0016	NOF /***
1014			/JMP ILLG IF < 512 PTS
1015	1220	1020	LDA I /YES
1016	1221	0000	DORG08, 0 /RESTORE AC, PROCEED
1017			/COMMAND CHAR IN AC
1020	1222	0061	DORG05, SET I 1
1021	1223	1240	INTTBL-1 /INTERPRETATION TABLE
1022	1224	0062	SET I 2
1023	1225	7766	-11 /-NUM LEGAL COMMANDS
1024	1226	0063	SET I 3
1025	1227	7252	JMPTBL+6000 /JUMP TABLE
1026	1230	1461	DORG06, SAE I 1 /IS COMMAND SAME AS AC
1027	1231	7233	JMP DORG07
1030	1232	6003	JMP 3 /YES, JUMP PROCESSING ROUTINE
1031	1233	0223	DORG07, XSK I 3
1032	1234	0222	XSK I 2
1033	1235	7230	JMP DORG06 /END, NO JUMP BACK
1034	1236	0063	SET I 3
1035	1237	4062	4062 /ERR CD 2
1036	1240	7764	JMP ILLG /YES, JUMP ILLEGAL
1037			/INTERPRETATION TABLE
1040	1241	0306	INTTBL, 306 /F
1041	1242	0255	255 /-
1042	1243	0253	253 /+
1043	1244	0302	302 /B
1044	1245	0317	317 /O
1045	1246	0305	305 /E
1046	1247	0330	330 /X
1047	1250	0320	320 /P
1050	1251	0325	325 /U
1051			/JUMP TABLE
1052	1252	7264	JMPTBL, JMP F1
1053	1253	7371	JMP MINUS1
1054	1254	7420	JMP PLUS1
1055	1255	7423	JMP B1
1056	1256	7467	JMP O1
1057	1257	7503	JMP E1
1060	1260	7510	JMP X1
1061	1261	7525	JMP PRNT1
1062	1262	7603	JMP U1

```

1063          /SUBROUTINE TO FILE POINT VALUE
1064      1263  0000  FTEMP,  0      /TEMP
1065      1264  1020  F1,    LDA I  /HAVE TOO MANY PTS BEEN FILED
1066      1265  0374          374
1067      1266  0063          SET I 3
1070      1267  4067          4067      /YES,ERROR 7
1071      1270  0017          COM
1072      1271  2005          ADD 5
1073      1272  0471          APO I
1074      1273  7764          JMP ILLG      /YES, ILLEGAL
1075          /NO, GET X VALUE SUBTRACT OFFSET
1076      1274  0644          LDF 4
1077      1275  1000          LDA
1100      1276  0025          OFFSET
1101      1277  0017          COM
1102      1300  1100          ADA
1103      1301  2022          2022
1104      1302  0646          LDF 6
1105      1303  5263          STC FTEMP      /SAVE
1106      1304  1000          LDA      /IF FRST PT,SKIP COMPARE
1107      1305  0005          5
1110      1306  1460          SAE I
1111      1307  0077          77
1112      1310  0456          SKP
1113      1311  7331          JMP F2ZXQ
1114      1312  0011          CLR
1115      1313  0046          SET 6
1116      1314  0005  POS5,  5
1117      1315  0226          XSK I 6
1120      1316  2027          ADD NUMPRA
1121      1317  0017          COM
1122      1320  2006          ADD 6  /IS X VALUE LESS THAN LAST X VALUE
1123      1321  4006          STC 6  /IN PTR 6
1124      1322  0063          SET I 3
1125      1323  4070          4070
1126          /ERR CD 8
1127      1324  1006          LDA 6
1130      1325  0017          COM
1131      1326  3263          ADD FTEMP
1132      1327  0451          APO
1133      1330  7764          JMP ILLG      /YES, ERROR
1134      1331  1000  F2ZXQ, LDA
1135      1332  1263          FTEMP
1136      1333  1065          STA I 5 /NO, STORE VALUE
1137          /MORE THAN ONE PARAMETER
1140      1334  1020          LDA I
1141      1335  0002          2
1142      1336  1440          SAE
1143      1337  0027          NUMPRA
1144      1340  7342          JMP F3
1145      1341  7351          JMP F2      /IF 1 IN AC,BUMP PTS
1146      1342  1000  F3,    LDA      /IF 2 PARA,PROC Y VAL
1147          /BMP NUM UNK PTS
1147      1343  0622          PONE
1150      1344  2035          ADD PTSUNK
1151      1345  4035          STC PTSUNK
1152      1346  6415  KEEPDR, JMP B6FRB0      /REFRESH DORETTE
1153      1347  6075          JMP CLLDRA
1154      1350  7210          JMP PROCMD      /PROCESS NEXT CHAR
1155          /STORE YVAL=CORVAL-OFFSET
1156      1351  0016  F2,    NOP      /REPLACE WITH SNS 5
1157          /IF FREE STANDING MODE DESIRED
1160      1352  7356          JMP G1
1161          /YES,CORVAL=OFFSET=KNOB 5X2!(YSCL-1)

```

```

1162      1353  7443  F4,      JMP R1
1163      1354  1065  F5,      STA I 5          /STORE
1164      1355  7342          JMP F3
1165          /SS5 OFF,STORE CORVAL-OFFSET
1166      1356  1000  G1,      LDA
1167      1357  6072          YOFFST+2000
1170      1360  0016          NOP
1171      1361  0644          LDF 4
1172      1362  1100          ADA
1173      1363  2023          2023
1174      1364  0646          LDF 6
1175      1365  7354          JMP F5
1176      1366  7436  YSCRNG, -341          /=SCR 1
1177      1367  7433          -344          /=SCR 4
1200      1370  0000  YSCTMP, 0
1201          /SUBROUTINE TO SCALE DISPLAY SMALLER BY HALF
1202      1371  1000  MINUS1, LDA
1203      1372  0622          PONE          /ADD 1 TO YSCALE
1204      1373  1100  MORP2,  ADA
1205      1374  6073          YSCALE+2000
1206      1375  1040          STA
1207      1376  1370          YSCTMP
1210      1377  0063          SET I 3
1211      1400  1366          YSCRNG
1212      1401  1103  MORP3,  ADA 3          /ADD -SCR 1
1213      1402  0451          APO
1214      1403  7413          JMP MORP4          /ERROR
1215      1404  1023          LDA I 3
1216      1405  3370          ADD YSCTMP
1217      1406  0471          APO I
1220      1407  7413          JMP MORP4          /ERROR TOO HIGH
1221      1410  0011          CLR
1222      1411  3370          ADD YSCTMP          /OK, CHANGE SCALE
1223      1412  7415          JMP MORP5
1224      1413  1003  MORP4,  LDA 3          /ERR,STR LIMIT
1225      1414  0017          COM
1226      1415  1040  MORP5,  STA
1227      1416  6073          YSCALE+2000
1230      1417  7206          JMP DORG04          /INITIALIZE DORA
1231          /SUBROUTINE TO SCALE DISPLAY BIGGER BY DOUBLE
1232      1420  1020  PLUS1,  LDA I
1233      1421  7776          7776
1234      1422  7373          JMP MORP2
1235          /SUBROUTINE TO REDEFINE BASELINE
1236      1423  0644  B1,      LDF 4
1237      1424  0016          NOP          /REPLACE WITH SNS 5 IF FREESTANDING
1240          /MODE OF DISPLAY DESIRED
1241      1425  7436          JMP C1
1242          /YES: OFFSET=CORVAL=(KNOB5)X2!(YSCL-1)
1243      1426  7443  B2,      JMP R1
1244      1427  0017          COM
1245      1430  1100          ADA
1246      1431  2023          2023          /CORVAL
1247      1432  0646  B3,      LDF 6
1250      1433  1040          STA
1251      1434  6072          YOFFST+2000          /STORE Y OFFSET
1252      1435  7206          JMP DORG04
1253          /NO SS5, YOFFSET==CORVAL
1254      1436  1000  C1,      LDA
1255      1437  2023          2023          /CORVAL
1256      1440  0017          COM
1257      1441  7432          JMP B3
1260          /SUB TO ROTATE KNOB 5 VAL 1 LFT FOR EVERY + DIG IN YSCL-1

```

1261	1442	0000	R0,	0	
1262	1443	0105	R1,	FRESAM	/SAM 5
1263	1444	5442		STC R0	
1264	1445	0646		LDF 6	
1265	1446	2666		ADD PM1	
1266	1447	1100		ADA	
1267	1450	6073		YSCALE+2000	
1270	1451	1560		BCL I	
1271	1452	7770		7770	
1272	1453	0017		COM	
1273	1454	4004		STC 4	/=YSCL+1
1274	1455	2000		ADD 0	
1275	1456	5462		STC R9	
1276	1457	3442		ADD R0	
1277	1460	0204		XSK 4	/NO ROTATES
1300	1461	7463		JMP R2	
1301	1462	6000	R9,	RETURN	
1302	1463	0241	R2,	ROL 1	
1303	1464	0224		XSK I 4	
1304	1465	7463		JMP R2	
1305	1466	7462		JMP R9	/OVER
1306				/SUBROUTINE TO SET UP OFFSET	
1307	1467	1000	01,	LDA	
1310	1470	0005		5	
1311	1471	0063		SET I 3	
1312	1472	4063		4063	
1313	1473	1460		SAE I	
1314	1474	0077		77	
1315	1475	7764		JMP ILLG	/IF PTS HAVE ALREADY BEEN STORED=ILLEGAL
1316	1476	0644		LDF 4	
1317	1477	1000		LDA	
1320	1500	2022		2022	
1321	1501	4025		STC OFFSET	/IF NOT, STORE, JUMP REFRESH DORETTE
1322	1502	7346		JMP KEEPDR	
1323				/SUBROUTINE TO ERASE ALL PREVIOUS UNKNOWN PTS	
1324	1503	7124	E1,	JMP CLR CRV	/CLEAR UNKNOWN CURVE
1325	1504	0065		SET I 5	/REINITIALIZE CURVE PTR
1326	1505	0077		77	
1327	1506	4035		STC PTSUNK	/SET NUM PTS=0
1330	1507	7346		JMP KEEPDR	/REFRESH DORETTE
1331				/SUBROUTINE TO EXIT DORETTE	
1332	1510	1000	X1,	LDA	
1333	1511	0035		PTSUNK	
1334	1512	0063		SET I 3	
1335	1513	4067		4067	
1336	1514	0470		AZE I	
1337	1515	7104		JMP DORART	/IF NO POINTS, EXIT,
1340	1516	0017		COM	
1341	1517	3314		ADD POS5	
1342	1520	0471		AP0 I	
1343	1521	7764		JMP ILLG	/IF LESS THAN 5 PTS, ILLEGAL
1344				/IF MORE THAN 5 POINTS, ADD SPECTRUM	
1345				/INST NAME IN INSTNUM, SPEC IN TY07A OF B7	
1346	1522	0604		LIF 4	
1347	1523	6707		JMP X2	/GO TO B4 PROCESSOR
1350				/SPECTRUM ADDED, BLOCK 0 WRITTEN OUT	
1351	1524	7104	X4,	JMP DORART	/RETURN TO DORETTE CALLER
1352				/SUBROUTINE TO PRINT VALUE OF POINTS ALREADY STORED VIA DORETTE	
1353	1525	0646	PRNT1,	LDF 6	
1354	1526	0500		IOB	
1355	1527	6041		6041	/TSF=CLR PRNT BUFF
1356	1530	7526		JMP ,=2	
1357	1531	1000		LDA	/INITIALIZE PRINT ROUTINE TYCNT

1360	1532	0035		PTSUNK
1361	1533	1040		STA
1362	1534	2056		NUMPTS+2000 /TELL NUM PTS TO PRINT
1363	1535	6415		JMP B6FRB0
1364	1536	6531		JMP TYB /GET HEADER
1365	1537	0646		LDF 6
1366	1540	1020		LDA I
1367	1541	2077		2077
1370	1542	1040		STA
1371	1543	2016		2016 /GET DATA PTR TO UNK, NOT LIB BLK
1372	1544	1020		LDA I
1373	1545	7234		JMP P4
1374	1546	1040		STA
1375	1547	2766		P2+2000 /BUMP UNK, NOT LIB PTR
1376	1550	1000		LDA
1377	1551	0027		NUMPRA
1400	1552	1040		STA
1401	1553	2047		PRMTRS+2000 /TELL NUM PARA
1402	1554	1020		LDA I
1403	1555	6734		JMP P5
1404	1556	0644		LDF 4
1405	1557	1040		STA
1406	1560	2005		2005 /SET UP RETURN TO P5 IN B4
1407	1561	0011		CLR
1410	1562	0606		LIF 6 /JUMP PRINT ROUTINE
1411	1563	6735		JMP TYCNT
1412				/PRINT ROUTINE ACCOMPLISHED, REFRESH DORETTE
1413	1564	7346	P6,	JMP KEEPDR
1414				/TEXT PROC INITIALIZATION SUB
1415	1565	5571	U1A,	STC U1AA
1416	1566	2000		ADD 0
1417	1567	5602		STC U1ARET
1420	1570	1020		LDA I
1421	1571	0000	U1AA,	0
1422	1572	6415		JMP B6FRB0
1423	1573	7237		JMP GETANS /ANS IN LOC 65
1424	1574	0066		SET I 6
1425	1575	2400		BUFB0+2000
1426	1576	0067		SET I 7
1427	1577	7774		7774
1430	1600	6415		JMP B6FRB0
1431	1601	7310		JMP BMULT /GET PROCESSED NUM IN AC
1432	1602	6000	U1ARET,	RETURN
1433				/SUBROUTINE TO COMPARE UNK SPECTRUM WITH LIB SPECTRA
1434				/OUTPUT MATCHES TO TTY
1435	1603	1020	U1,	LDA I
1436	1604	2400		BUFB0+2000
1437	1605	0645		LDF 5
1440	1606	1040		STA
1441	1607	2022		ANSWER+2000 /SET UP ANS BUFF AT LOC 65 OF B0
1442	1610	0063		SET I 3
1443	1611	4062		4062
1444	1612	0011		CLR
1445	1613	4036		STC COMMIS
1446	1614	1020		LDA I /DISPLAY ALLOWABLE ERROR TOL
1447	1615	0336		DSP2P1
1450	1616	7565		JMP U1A
1451				/PROC NUM IN AC
1452				/GET PERCENT OR ABSOL
1453	1617	1460		SAE I
1454	1620	0001		1
1455	1621	7627		JMP U2
1456				/1, PERCENT

1457	1622	1000	LDA
1460	1623	0051	FLAGWD
1461	1624	1620	BSE I
1462	1625	2000	2000 /SET BIT 1 FLAGWD
1463	1626	7636	JMP U3
1464	1627	1460	SAE I
1465	1630	0002	2
1466	1631	7764	JMP ILLG /IF NOT 1, 2 ILLEGAL
1467	1632	1000	LDA
1470	1633	0051	FLAGWD
1471	1634	1560	BCL I /ABSL, CLEAR BIT
1472	1635	2000	2000
1473			/PROCESS PARAMETER TOLERANCES
1474	1636	0066	U3, SET I 6
1475	1637	2401	BUFB0+2001
1476	1640	4051	STC FLAGWD /PROCESS PARAMETER 1
1477	1641	7660	JMP UA
1500			/VALUE OCTAL OR DECIMAL IS IN AC
1501	1642	0451	APO
1502	1643	7764	JMP ILLG /IF NEGATIVE, ERROR
1503	1644	4030	STC TLRNCE /ELSE STORE PRA 1
1504	1645	2027	ADD NUMPRA
1505	1646	1460	SAE I
1506	1647	0002	2
1507	1650	7700	JMP U4 /IF ONE PARA, GO ON
1510	1651	0066	SET I 6
1511	1652	6403	BUFB0+6003
1512	1653	7660	JMP UA /ELSE PROCESS SECOND
1513	1654	0451	APO
1514	1655	7764	JMP ILLG /IF NEG, ERROR
1515	1656	4031	STC TLRNCE+1 /ELSE STORE PARA2
1516	1657	7700	JMP U4
1517			/PROCESS PARAMETER TOLERANCE, SUB
1520	1660	2000	UA, ADD 0
1521	1661	5674	STC UARET
1522	1662	0067	SET I 7
1523	1663	7773	7773
1524	1664	2051	ADD FLAGWD
1525	1665	0241	ROL 1
1526	1666	0471	APO I
1527	1667	7675	JMP UB /IF PERCNT, ONLY 2 DIG ALLOWED
1530	1670	0227	XSK I 7
1531	1671	0011	CLR /AC=+0
1532	1672	6415	UC, JMP B6FRB0
1533	1673	7310	JMP BMULT /DO CONVERT 2 DECIMAL
1534	1674	6000	UARET, RETURN
1535	1675	0011	UB, CLR
1536	1676	0016	NOP
1537	1677	7672	JMP UC /DO CONVERT 3 ABSOLUTE DEC
1540	1700	2051	U4, ADD FLAGWD
1541	1701	0241	ROL 1
1542	1702	0471	APO I
1543	1703	7726	JMP U7 /IF ABSOLUTE, GO ON
1544			/PERCENT, CONVERT TO ABSOLUTE
1545	1704	1000	LDA
1546	1705	0040	PRCNT1
1547	1706	4060	STC XNMBUF
1550	1707	2041	ADD PRCNT1+1
1551	1710	4061	STC XNMBUF+1 /GET MULT NUM AS 1 PERCNT
1552	1711	0066	SET I 6
1553	1712	0052	PRCT1 /SET PERCENT TOL 1
1554	1713	2030	ADD TLRNCE
1555	1714	7026	JMP XNUM /PARA 1 PERCENT SET

1556	1715	2027		ADD NUMPRA	
1557	1716	1460		SAE I	
1560	1717	0002		2	
1561	1720	7726		JMP U7 /IF ONE PARA GO ON	
1562	1721	0066		SET I 6	
1563	1722	0054		PRCT1+2	
1564	1723	0011		CLR	
1565	1724	2031		ADD TLRNCE+1	
1566	1725	7026		JMP XNUM /PARA 2 PERCENT SET UP	
1567				/GET NUM MISSES ALLOWED, SAME ANS BUFF	
1570	1726	0645	U7,	LDF 5	
1571	1727	1020		LDA I	
1572	1730	0431		DSP2P2	
1573	1731	7565		JMP U1A /PROCESSED NUM IN AC	
1574	1732	4033		STC MISSES /STORE NUM MISSES	
1575	1733	2033		ADD MISSES	
1576	1734	0017		COM	
1577	1735	2035		ADD PTSUNK	
1600	1736	0063		SET I 3	
1601	1737	4066		4066	
1602	1740	0451		AP0	
1603	1741	7764		JMP ILLG /IF NUM PTS<NUM MISSES, ERROR	
1604				/ALL OK, DO MATCH	
1605	1742	0604		LIF 4	
1606	1743	6743		JMP U8	
1607				/SPECTRUM MATCHES OUTPUTTED	
1610	1744	7346	U9,	JMP KEEPDR /REFRESH DORETTE	
1611				/SOMETHING ILLEGAL HAS BEEN ENTERED	
1612				/MUST RESTORE ANSWER BUFF	
1613	1745	1020	ILLGL,	LDA I	
1614	1746	2400		BUF84+2000	
1615	1747	0645		LDF 5	
1616	1750	1040		STA	
1617	1751	2022		ANSWER+2000	
1620	1752	1020		LDA I	
1621	1753	0657		DSPERA	
1622	1754	6415	ILLGL1,	JMP B6FRB0	
1623	1755	7237		JMP GETANS /WAIT FOR CR	
1624	1756	6415		JMP B6FRB0	
1625	1757	6075		JMP CLLDRA /WAIT FOR CHAR	
1626	1760	7210		JMP PROCMD /YES, PROCESS IT	
1627	1761	1020	NOTUNQ,	LDA I	
1630	1762	0657		DSPERA	
1631	1763	7754		JMP ILLGL1 /DISPLAY ADD SPEC NOT UNIQUE	
1632	1764	1000	ILLG,	LDA /STR CODE IN PTR 3	
1633	1765	0003		3	
1634	1766	0645		LDF 5	
1635	1767	1040		STA	
1636	1770	2663		ERRCXX+2000	
1637	1771	7745		JMP ILLGL	
1640				CHAIN "LIFE B4"	

```
0000          *20
0001          /LIFE MAINLINE PROCESSING
0002          /START DISPLAY INTERPRETATION
0003          SEGMENT 4
0004          *17
0005          0017 6201 FLDZ0, 6201          /CDF 1=DORA
0006          /LOC 21-24 ARE DORETTE PTRS
0007          *26
0010          0026 0647 INITDL, LDF 7
0011          0027 0700          RDC
0012          0030 6322          6322
-
```

0013	0031	0700	RDC
0014	0032	7323	7323
0015	0033	0002	PDP
0016			PMODE
0017	0034	6032	KCC
0020	0035	6046	TLS
0021	0036	6141	LINC
0022			LMODE
0023	0037	7066	JMP STRT
0024			/CONSTANTS, TEMP STOR, REF, FLAGS
0025	0040	7777	DIAL 77, 7777
0026			READ=7774
0027			WRITE=7775
0030	0041	6000	RTN, RETURN /RETURN, INIT TP
0031	0042	7774	PREAD, READ
0032	0043	7775	PWRITE, WRITE
0033			/PARAMETERS - BLOCK 0
0034	0044	0000	PARA0, 0 /TAPE UNIT = SET FROM QUANDA
0035	0045	0034	34 /CORE LOCATION - B7Q0
0036	0046	0000	0 /ST BLK
0037	0047	0001	1 /BLKS
0040	0050	0000	NAMETP, 0 /4 CHAR TAPE NAME
0041	0051	0000	0
0042	0052	6777	NUMDIS, 6777 /- NUM PTS DISP
0043			/DO SUBROUTINE IN B6 - PTRS 10,11
0044	0053	0261	DOSUB, ROL I 1 /SAVE BIT 0
0045	0054	0301	ROR 1
0046	0055	0353	SCR 13
0047	0056	1000	LDA
0050	0057	0000	0
0051	0060	1040	STA
0052	0061	0011	11 /RETURN JUMP TO MAINLINE CALL
0053	0062	1560	BCL I
0054	0063	6000	SPCCST, 6000 /CONSTANT IN SPCSR ROUT
0055	0064	4010	STC 10
0056	0065	0644	LDF 4
0057	0066	1010	LDA 10 /CONTENTS OF NEXT LOC - JUMP SUB
0060	0067	0231	XSK I 11
0061	0070	0606	LIF 6
0062	0071	6020	JMP B6CALL
0063	0072	6011	JMP 11
0064			/PARAMETERS - REST OF LIFE TAPE
0065	0073	0000	PARA, 0 /TAPE UNIT = SET FROM QUANDA
0066	0074	0035	35 /CORE LOCATION - B7,Q
0067	0075	0000	0 /ST BLK - SET FROM SUBROUTINES
0070	0076	0001	1 /BLKS
0071	0077	0000	NUMPT4, 0 /PARAPTS
0072	0100	0000	NUMPAR, 0 /DATA PARA
0073	0101	0000	INSTNM, 0 /4 CHAR INST NAME
0074	0102	0000	0
0075	0103	0000	FSTBLK, 0 /FIRST BLK OF INST
0076	0104	7775	M2, 7775 /CONSTS
0077	0105	0001	P1B4, 0001
0100	0106	0000	ERAST, 0
0101			/SUBROUTINE - CHECK IF LIFE TAPE
0102			/PTRS 5,6,7 BLOCK 0 OF LIFE TAPE IN B7Q1
0103			/IF LIFE, BUMP RET, ELSE NOT
0104	0107	1020	CKTPIN, LDA I /SET FOR FIRST 8 WORDS
0105	0110	2377	2377
0106	0111	4006	STC 6
0107	0112	0065	SET I 5
0110	0113	7767	7767 /IN QUARTER1 B7
0111	0114	0647	LDF 7

```

0112      0115  6000      JMP 0
0113      0116  0047  CKTP,  SET 7  /THIS MUST ALSO BE CALLED *
0114      0117  0000      0
0115      0120  1025      LDA I 5 /GET NEXT WD
0116      0121  1026      LDA I 6
0117      0122  1440      SAE
0120      0123  0005      5      /IS IT CORRECT
0121      0124  6007      JMP 7  /NO, GET OUT
0122      0125  0205      XSK 5  /YES, OVER?
0123      0126  6120      JMP CKTP+2
0124      0127  0227  CKTPB, XSK I 7 /YES, BUMP, EXIT
0125      0130  6007      JMP 7
0126      /SUBROUTINE TO INITIALIZE LIFE TAPE - OR DELETE ALL
0127      /SET UP BLK 0 IN B300
0130      0131  0047  INTP,  SET 7  /SET PTRS
0131      0132  0000      0
0132      0133  6107      JMP CKTPIN
0133      0134  1025  INTPA,  LDA I 5 /STORE 7770-7777
0134      0135  1000      LDA
0135      0136  0005      5
0136      0137  1066      STA I 6
0137      0140  0205      XSK 5
0140      0141  6134      JMP INTPA
0141      0142  0011  INTPB,  CLR      /WHEN FINISHED, STORE REST AS 0
0142      0143  1066      STA I 6
0143      0144  1000      LDA
0144      0145  0006      6
0145      0146  1460      SAE I
0146      0147  2777      2777
0147      0150  6142      JMP      INTPB
0150      /STORE DAD NULL FOR BLK0, TRAILER
0151      0151  0011      CLR
0152      0152  1620      BSE I  /TRAILER
0153      0153  0077      77
0154      0154  1046      STA 6
0155      0155  1000      LDA      /BLK0
0156      0156  2725      2725
0157      0157  1620      BSE I
0160      0160  4000      4000
0161      0161  1040      STA
0162      0162  2725      2725
0163      0163  6007      JMP 7
0164      EJECT

```

```

0165          /SUBROUTINE SET TO ERASE AN INSTRUMENT
0166          /B0 IN BNK 7 Q0
0167          /SUB1 = IDENTIFY INSTRUMENT, GET STARTING BLOCK
0170          /RET IF NONE, BUMP IF FOUND, 2 BUMPS IF OVERFLOW. PTR6 HAS 0 OR 7777
0171      0164  0066  ER1,  SET I 6
0172      0165  2006          2006
0173      0166  0226          XSK I 6
0174      0167  0226          XSK I 6
0175      0170  0047          SET 7
0176      0171  0000          0
0177      0172  0647  ER0C,  LDF 7
0200      0173  1006  ER1A,  LDA 6  /IS THIS END - NEXT WD 0
0201      0174  0470          AZE I
0202      0175  6007          JMP 7  /YES, ERROR RETURN, PTR6 HAS FIRST 0
0203          /COMPARE FIRST 2 CHAR
0204      0176  1440          SAE
0205      0177  0101          INSTNM
0206      0200  6226          JMP ER1B
0207      0201  1026          LDA I 6
0210      0202  1440          SAE
0211      0203  0102          INSTNM+1
0212      0204  6227          JMP ER1B+1
0213      0205  1026          LDA I 6 /MATCH MADE, GET FIRST BLK
0214      0206  1560          BCL I
0215      0207  6000          6000
0216      0210  4103          STC  FSTBLK
0217          /MATCH MADE, STORE NUM PARA
0220      0211  1006          LDA 6
0221      0212  0242          ROL 2
0222      0213  1560          BCL I
0223      0214  7774          7774
0224      0215  0646          LDF 6
0225      0216  1040          STA
0226      0217  2047          PRMTRS+2000
0227      0220  0640          LDF 0
0230      0221  1040          STA
0231      0222  2027          NUMPRA+2000
0232      0223  4100          STC NUMPAR
0233      0224  0647          LDF 7
0234      0225  6240          JMP ER1C
0235      0226  0226  ER1B,  XSK I 6 /GET TO NEXT INSTRUMENT
0236      0227  0226          XSK I 6
0237      0230  0226          XSK I 6
0240      0231  1020          LDA I
0241      0232  5457          5457  /MAKE SURE INDEX DOES NOT OVERFLOW
0242      0233  2006          ADD 6
0243      0234  0451          APO
0244      0235  6173          JMP ER1A  /OK, RETURN
0245      0236  0011          CLR
0246      0237  0227          XSK I 7
0247      0240  0227  ER1C,  XSK I 7
0250      0241  6007          JMP 7  /INDEX OVERFLOW, 2 BUMPS
0251          /SUBROUTINE FOR MATCH SEARCH OF TAPE INDEX
0252          /MATCH = 0 BUMPS, OVERFLOW = 1 BUMP, NO MATCH = 2 BUMPS
0253      0242  0044  ER0,  SET 4
0254      0243  0000          0
0255      0244  6164          JMP ER1 /JUMP MATCH
0256      0245  6251          JMP .+4
0257      0246  6004          JMP 4  /IF MATCH, 0 BUMPS
0260      0247  0224  ER0A,  XSK I 4 /IF OVERFLOW
0261      0250  6004          JMP 4
0262      0251  0451          APO  /IF NO MATCH, CHECK FOR 7777
0263      0252  6255          JMP ER0B  /YES, RETURN

```

0264	0253	0224		XSK I 4	
0265	0254	6247		JMP ER0A	/NO MATCH, 2 BUMPS
0266	0255	0226	ER0B,	XSK I 6	
0267	0256	0226		XSK I 6	
0270	0257	0226		XSK I 6	
0271	0260	6172		JMP ER0C	/REENTRENT TO ER0
0272				/SUB2 = DELETE INSTRUMENT, GIVEN ST BLK	
0273				/PTR6 AT FST BLK OF INSTRUMENT	
0274	0261	0011	ER2,	CLR	
0275	0262	2103		ADD FSTBLK	
0276	0263	4075	ER2A,	STC PARA+2	/SETUP READ PTRS
0277	0264	0647		LDF 7	
0300	0265	6307		JMP ER2S1	/SUB SUB TO CLR BIT COORESP TO WD IN PARA+2
0301	0266	2075		ADD PARA+2	
0302	0267	6053		JMP DOSUB	
0303	0270	6150		JMP RDTAPE	/DO TPAPERREAD OF NEXT BLK
0304	0271	1000		LDA	/WAS THIS THE LAST BLK
0305	0272	2777		2777	
0306	0273	0450		AZE	
0307	0274	6263		JMP ER2A	/NO, CLR NEXT DAD BIT
0310	0275	2104		ADD M2	
0311	0276	2006		ADD 6	/YES, STORE 7777 IN INDEX FILE
0312	0277	4006		STC 6	
0313	0300	0017		COM	
0314	0301	1046		STA 6	
0315	0302	1066		STA I 6	
0316	0303	1066		STA I 6	
0317	0304	6053	ER2RTN,	JMP DOSUB	/JUMP WRITE UNIT 0
0320	0305	7566		JMP WTUN0	
0321	0306	7127		JMP STRTB	
0322				/SUB SUB TO CLR BIT COORSP TO WD IN PARA 2	
0323	0307	1000	ER2S1,	LDA	
0324	0310	0000		0	
0325	0311	4350		STC ER2SRT	
0326	0312	4004		STC 4	/WD CNT
0327	0313	2075		ADD PARA+2	
0330	0314	4106		STC ERAST	
0331	0315	0065		SET I 5	/=12 BITS
0332	0316	7763		7763	
0333	0317	2106	ER2S2,	ADD ERAST	/GET PROPER WD
0334	0320	2005		ADD 5	
0335	0321	0470		AZE I	
0336	0322	0011		CLR	
0337	0323	0451		AP0	
0340	0324	6330		JMP ER2S3	/AT WD
0341	0325	0224		XSK I 4	
0342	0326	4106		STC ERAST	
0343	0327	6317		JMP ER2S2	
0344				/AT WD, ROTATE 0001 LEFT 1 BIT FOR EVERY NEG INT FROM 12 DIV	
0345	0330	4007	ER2S3,	STC 7	
0346	0331	2105		ADD P1B4	
0347	0332	0241		ROL 1	
0350	0333	0227		XSK I 7	
0351	0334	6332		JMP ER2S3+2	
0352	0335	0301		ROR 1	
0353	0336	4007		STC 7	/PROPEL BIT MASK SET
0354	0337	2004		ADD 4	
0355	0340	1120		ADA I	/START OF DAD IN BLK 0
0356	0341	2324		2324	
0357	0342	4004		STC 4	/SET FIRST LOC OF BIT MAP
0360	0343	1024		LDA I 4	
0361	0344	1540		BCL	/DO BIT CLEAR
0362	0345	0007		7	

0363	0346	1044		STA 4
0364	0347	0011		CLR
0365	0350	6000	ER2SRT,	RETURN
0366				/SUBROUTINE TO PRINT SPECTRUM DATA
0367				/PTRS 10, 11, 12, 1, 13-17 USED IN SUBSUB
0370				/HEADER ALREADY ASSUMED PRINTED
0371				/B0 IN B700
0372				/AC=0 IF NO MATCH, =4000 IF MATCH
0373				/4 CHAR NAME IN INSTNM
0374	0351	0045	TYC,	SET 5 /SAVE RET
0375	0352	0000		0
0376	0353	6242		JMP ER0 /FIND INSTRUMENT
0377	0354	6357		JMP TYCA /MATCH, DO PRINTOUT
0400	0355	0016		NOP /OVERFLOW ILLEGAL
0401	0356	6005		JMP 5 /NO MATCH, EXIT
0402	0357	2103	TYCA,	ADD FSTBLK
0403	0360	0606		LIF 6
0404	0361	6655		JMP TYC1
0405				EJECT

```

0406 /SUBROUTINE TO PRINT ALL MATCHING LIBRARY CURVES
0407 /FOR UNKNOWN SPECTRUM IN B0
0410 /INSTNM BUFFER SET UP
0411 /AC=0, NO MATCH ON INST, A NOT=0, OK
0412 /ALL PARA IN B0, B4, B6 ASSUMED SET UP
0413 0362 1000 LBPR, LDA
0414 0363 0000 0
0415 0364 4370 STC LBPRRT
0416 0365 6242 JMP ER0 /GET FIRST BLOCK OF INSTRUMENT
0417 0366 6371 JMP LBPR
0420 0367 0016 NOP
0421 0370 6000 LBPRRT, RETURN
0422 0371 2103 LBPR, ADD FSTBLK
0423 0372 6053 JMP DOSUB
0424 0373 6150 JMP RDTAPE /READ IN FIRST DATA BLK
0425 0374 0606 LIF 6
0426 0375 7020 JMP LBPRB /GO TO B6 FOR PRINTOUT
0427 *400
0430 0400 0000 BUFB4, 0
0431 *415
0432 /SUBROUTINE TO DELETE A SPECTROM
0433 /WHOSE NAME IS IN TY07A OF B5
0434 /AC=0 IF DELETED, AD - IF NO INST, + IF NO SPECTRA
0435 0415 1000 DELSP, LDA
0436 0416 0000 0
0437 0417 4424 STC DELSRT
0440 0420 6242 JMP ER0 /GET FIRST BLOCK
0441 0421 6425 JMP DELSPA
0442 0422 0016 NOP
0443 0423 2063 ADD SPCST
0444 0424 6000 DELSRT, RETURN /ERROR, NOT FOUND, AC NEG
0445 0425 2103 DELSPA, ADD FSTBLK
0446 0426 6053 JMP DOSUB /READ IN FIRST DATA BLOCK FIND MATCH
0447 0427 7155 JMP FNDSPB
0450 0430 0450 AZE
0451 0431 6424 JMP DELSRT /RETURN, NO SPEC MATCH, AC +
0452 /MATCH, DELETE SPEC
0453 /PTR 16 AT LAST SPEC WD
0454 0432 0016 DELSPC, NOP
0455 0433 0016 NOP
0456 0434 0011 CLR /AT FRST TAPE CHARS
0457 0435 0646 LDF 6 /STORE 0 IN LOC
0460 0436 1000 LDA
0461 0437 2016 2016
0462 0440 4003 STC 3
0463 0441 0647 LDF 7
0464 0442 1043 STA 3
0465 0443 2075 ADD PARA+2
0466 0444 6053 JMP DOSUB
0467 0445 6173 JMP WTTAPE /WRITE IT
0470 0446 6424 JMP DELSRT /RETURN OK, AC=0
0471 /B4 PART OF B6 SUB TO STORE IN LIFE BLK
0472 0447 6516 STRLFB, JMP FNDAD
0473 0450 6726 JMP ERNNX /IF NO BLKS LEFT, JUMP ERROR
0474 0451 2515 ADD ADSBLK /BLOCK ASSIGNED, IN AC
0475 0452 0606 LIF 6
0476 0453 7217 JMP STRLFC
0477 /TRANSFER=NUM WDS IN PTR 6
0500 /FROM PTR 7 TO PTR 16 B7. PTR 16 AT START OF BUFF, NOT -1
0501 /ASSUME LDF=4
0502 /PTR 16 ENDS AT NEXT WD AFTER BUFF
0503 0454 1000 INSRT, LDA
0504 0455 0000 0

```

```

0505      0456 4464      STC INSRN
0506      0457 1027 INSRTA, LDA I 7 /GET NEXT WD
0507      0460 6053      JMP D0SUB
0510      0461 7203      JMP STRLF      /STORE
0511      0462 0226      XSK I 6 /END
0512      0463 6457      JMP INSRTA      /NO, GO BACK
0513      0464 6000 INSRN, RETURN /YES
0514      /SUBROUTINE TO ADD A SPECTRUM
0515      /WHOSE NAME IS IN TY07A OF B5, INST NAME IN INSTNM
0516      /EXIT IF NAME REDUNDANT
0517      /ONE BUMP IF NO MORE ROOM IN INDEX OR TAPE
0520      /TWO BUMPS IF OK
0521      /PTRS BY ERO HAS 4,6,7, USE 12,3
0522      0465 0000 ADSTMP, 0      /LOC BLK 0 OF FIRST 7777, 0 IF UNFILLED
0523      0466 0000      0
0524      0467 1000 ADSSP, LDA      /SAVE RET, INIT TRMP
0525      0470 0000      0
0526      0471 4002      STC 2
0527      0472 4465      STC ADSTMP
0530      0473 4466      STC ADSTMP+1
0531      /FIND IF INSTRUMENT EXISTS
0532      0474 6164      JMP ER1
0533      0475 6505      JMP ADSSP1      /NO MATCH
0534      0476 6617      JMP ADSSPA      /MATCH
0535      /CHECK IF DELETED SPECTRA FOUND
0536      /BEFORE END REACHED
0537      0477 1000      LDA
0540      0500 0465      ADSTMP
0541      0501 0450      AZE
0542      0502 6565      JMP ADSSP5      /STORE IN DELETED AREA
0543      0503 0222 ADSBMP, XSK I 2 /INDEX OVERFLOW
0544      0504 6002      JMP 2      /BUMP RETURN, EXIT
0545      /NO MATCH, EITHER END OF INDEX OR DEL INST
0546      0505 0471 ADSSP1, APO I
0547      0506 6557      JMP ADSSP2
0550      0507 2465      ADD ADSTMP      /DELETED INST, SAVE LOC
0551      0510 0450      AZE
0552      0511 6255      JMP ER0B      /UNLESS PRIOR ONE FOUND
0553      0512 2006      ADD 6
0554      0513 4465      STC ADSTMP
0555      0514 6255      JMP ER0B      /RET
0556      0515 0000 ADSBLK, 0
0557      /SEARCH DAD MAP BLK0, GET BLK NUM COORESP
0560      /TO FIRST FREE BIT IN ADSBLK, SET BIT, BMP RETURN
0561      /IF NO FREE BLOCKS, RET
0562      /PTRS 3,5,10,11
0563      0516 1000 FNDAD, LDA
0564      0517 0000      0
0565      0520 4012      STC 12 /SAVE RET
0566      0521 4013      STC 13 /INIT BLK CNT
0567      0522 0647      LDF 7
0570      0523 0063      SET I 3 /SET WD TO STRT OF MAP
0571      0524 2324      2324
0572      0525 0065 FNDAD1, SET I 5 /RESET BIT CNT
0573      0526 7763      7763
0574      /START NEXT WD
0575      0527 1023 FNDAD2, LDA I 3
0576      0530 0471      APO I /IS BIT A 0
0577      0531 6544      JMP FNDAD3
0600      0532 0241      ROL 1 /NO, ROTATE
0601      0533 0233      XSK I 13      /BUMP BLK CNT
0602      0534 0225      XSK I 5 /IS IT END OF WD
0603      0535 6530      JMP FNDAD2+1

```

0604	0536	1000	LDA	
0605	0537	0003	3	
0606	0540	1460	SAE I	/END OF DAD ?
0607	0541	2377	2377	
0610	0542	6525	JMP FNDAD1	/NO GET NEXT, ELSE
0611	0543	6012	JMP 12	/RETURN
0612			/OPEN BLOCK FOUND, SET BIT, GET IN ADSBLK	
0613	0544	1620	FNDAD3, BSE I	
0614	0545	4000	4000	
0615	0546	0241	ROL 1	
0616	0547	0225	XSK I 5	/REROTATE
0617	0550	6546	JMP .=2	
0620	0551	1043	STA 3	
0621	0552	1000	LDA	
0622	0553	0013	13	
0623	0554	4515	STC ADSBLK	
0624	0555	0232	XSK I 12	
0625	0556	6012	JMP 12	/RETURN
0626			/END OF INDEX. ADD ENTRY	
0627			/PTR 6 AT INDEX ENTRY WD1	
0630	0557	6516	ADSSP2, JMP FNDAD	/GET FIRST DAD LOC
0631	0560	6503	JMP ADSBMP	/TAPE FULL, EXIT
0632			/TRANSFER 3 WD ENTRY	
0633	0561	1000	LDA	
0634	0562	0465	ADSTMP	/ANY DEL ENTRIES
0635	0563	0470	AZE I	
0636	0564	6567	JMP ADSSP4	/NO, STORE
0637	0565	0046	ADSSP5, SET 6	
0640	0566	0465	ADSTMP	/YES, FILL IT
0641	0567	1000	ADSSP4, LDA	
0642	0570	0515	ADSBLK	
0643	0571	4103	STC FSTBLK	
0644	0572	1000	ADSSP3, LDA	
0645	0573	0101	INSTNM	
0646	0574	1046	STA 6	
0647	0575	1000	LDA	
0650	0576	0102	INSTNM+1	
0651	0577	1066	STA I 6	/STORE INST NAME
0652	0600	1000	LDA	
0653	0601	0100	NUMPAR	
0654	0602	0302	ROR 2	
0655	0603	2515	ADD ADSBLK	
0656	0604	1066	STA I 6	/STORE NUM PAR, INIT BLK NUM
0657	0605	1000	LDA	
0660	0606	0515	ADSBLK	
0661	0607	6053	JMP DOSUB	/READ BLOCK
0662	0610	6150	JMP RDTAPE	
0663	0611	1020	LDA I	
0664	0612	2402	2402	
0665	0613	0646	LDF 6	
0666	0614	1040	STA	
0667	0615	2016	2016	/SET PTR 16 TO START OF STORAGE
0670	0616	6626	JMP ADSSPX	/JMP TO TRANSFER
0671			/MATCH MADE IN INDEX, DO SEARCH FOR REDUNDANT SPEC	
0672			/INSTRUMENT ALREADY HAS CURVES	
0673			/SEE IF ONE TO BE ADDED IS REDUNDANT	
0674	0617	1006	ADSSPA, LDA 6	/GET FIRST BLOCK
0675	0620	1560	BCL I	
0676	0621	6000	6000	
0677	0622	6053	JMP DOSUB	
0700	0623	7155	JMP FNDSBP	/CHECK MATCH
0701	0624	0470	AZE I	
0702	0625	6002	JMP 2	/IF MATCH, EXIT

```

0703 /NO MATCH, PTR 16 AT FIRST NEW LOCATION IN SPECTRA
0704 /TRANSFER IN SPECTRUM DATA
0705 0626 0066 ADSSPX, SET I 6
0706 0627 7767 7767
0707 0630 0067 SET I 7
0710 0631 1531 TY07A=1
0711 0632 6454 JMP INSRT /TRANSFER NEW SPECTRUM TO FILE
0712 0633 0066 SET I 6
0713 0634 7775 7775
0714 0635 0067 SET I 7
0715 0636 0047 NAMETP+7776
0716 0637 6454 JMP INSRT /TRANSFER TAPE NAME
0717 0640 0640 LDF 0
0720 0641 1000 LDA
0721 0642 2022 PARDAT+2002
0722 0643 6053 JMP DOSUB
0723 0644 7203 JMP STRLF /STORE ST BLK NUM
0724 0645 0640 LDF 0
0725 0646 1000 LDA
0726 0647 2035 PTSUNK+2000
0727 0650 1040 STA
0730 0651 0077 NUMPT4
0731 0652 6053 JMP DOSUB
0732 0653 7203 JMP STRLF /STORE NUM PTS IN SPECTRUM
0733 0654 0067 SET I 7
0734 0655 2077 2077
0735 0656 0640 LDF 0
0736 0657 2077 ADD NUMPT4 /GET-NUM PTS X NUM PARA
0737 0660 1240 MUL
0740 0661 0100 NUMPAR
0741 0662 0017 COM
0742 0663 4004 STC 4 /MUST RESET LDF TO B0 EACH LINE
0743 0664 0066 V2, SET I 6
0744 0665 7776 7776
0745 0666 0640 LDF 0
0746 0667 6454 JMP INSRT
0747 0670 0224 XSK I 4
0750 0671 6664 JMP V2
0751 0672 0017 COM
0752 0673 6053 JMP DOSUB
0753 0674 7203 JMP STRLF /STORE TERMINATING 7777
0754 0675 0017 COM
0755 0676 0647 LDF 7
0756 0677 1040 STA
0757 0700 2777 2777 /AFTER CURVE AND AS LAST WD OF BLK
0760 /WRITE OUT LAST BLOCK,
0761 0701 0011 CLR
0762 0702 2075 ADD PARA+2
0763 0703 6053 JMP DOSUB
0764 0704 6173 JMP WTTAPE
0765 0705 0222 XSK I 2
0766 0706 6503 JMP ADSBMP /RETURN, BUMP TWICE
0767 /DORETTE HANDLER TO ADD SPECTRUM
0770 0707 6467 X2, JMP ADSSP
0771 0710 6731 JMP ERNNU /JUMP ERROR, NAME NOT UNIQUE
0772 0711 6726 JMP ERNNX /JUMP ERROR, NO MORE ROOM
0773 /OK, SPECTRUM ADDED
0774 /NOW WRITE BLOCK 0
0775 0712 0002 PDP
0776 PMODE
0777 0713 6211 CDF 10
1000 0714 4443 JMS I PWRITE
1001 0715 0044 PARA0

```

1002	0716	6141		LINC	
1003				LMODE	
1004	0717	0600		LIF 0	
1005	0720	7524		JMP X4	
1006	0721	0640	X3,	LDF 0	/ILLEGAL CODE CALLER
1007	0722	1040		STA	
1010	0723	2003		2003	
1011	0724	0600		LIF 0	/JMP ERR,NO MORE ROOM
1012	0725	7764		JMP ILLG	
1013	0726	1020	ERNNX,	LDA I	
1014	0727	4071		4071	
1015	0730	6721		JMP X3	/ERROR 9
1016	0731	1020	ERNNU,	LDA I	
1017	0732	4061		4061	/ERROR 1
1020	0733	6721		JMP X3	
1021				/DORETTE PRINT ROUTINE RESTORER	
1022	0734	1020	P5,	LDA I	
1023	0735	6244		JMP TRANSB	
1024	0736	0646		LDF 6	
1025	0737	1040		STA	
1026	0740	2766		P2+ 2000	
1027	0741	0600		LIF 0	
1030	0742	7564		JMP P6	/JMP BACK
1031				/MATCH SPECTRUM FOR DORETTE	
1032	0743	6362	U8,	JMP LBPR	
1033	0744	7056		JMP B4INTB	/REINIT ANS BUFF
1034	0745	0600		LIF 0	
1035	0746	7744		JMP U9	/PRINTOUT OK, EXIT
1036				/HELP INITIALIZE DISPLAY ROUTINE	
1037				/PTR7 MUST BE SET, PROCESSED NUM IN AC	
1040	0747	4753	HELP DS,	STC HELP1	
1041	0750	2000		ADD 0	
1042	0751	4763		STC HELPRT	
1043	0752	1020	HELP2,	LDA I	
1044	0753	0000	HELP1,	0	
1045	0754	6053		JMP DOSUB	
1046	0755	7237		JMP GETANS	/OCTAL ANS IN 1365
1047	0756	0066		SET I 6	
1050	0757	2400		BUFB4+2000	
1051	0760	0017		COM	/MAKE OCTAL
1052	0761	6053		JMP DOSUB	
1053	0762	7310		JMP BMULT	/ANS CONV, PUT INAC
1054	0763	6000	HELPRT,	RETURN	
1055				/ERROR, DISPLAY, THEN BACK TO SAME DISPLAY	
1056	0764	1020	MNLNER,	LDA I	/DISPLAY ILLEGAL = ON NUM CONV
1057	0765	4062		4062	
1060	0766	0645		LDF 5	
1061	0767	1040		STA	
1062	0770	2663		ERRCXX+2000	/ERROR 2 IF NEEDED
1063	0771	1020		LDA I	
1064	0772	0656		DSPERB	
1065	0773	6053	MNLNE1,	JMP DOSUB	/GET CR
1066	0774	7237		JMP GETANS	
1067	0775	6752		JMP HELP2	/REDISPLAY LAST DISPLAY
1070				/MOVE = NUM HALF WDS IN PTR 6	
1071				/FROM PTR 5 BUF	
1072				/TO PRT 7 BUFF	
1073				/0 BECOMES 40	
1074	0776	0040	P40,	40	
1075	0777	1000	SHOVE,	LDA	
1076	1000	0000		0	
1077	1001	5013		STC SHOVER	
1100	1002	1325	SHOVEA,	LDH I 5	

```

1101      1003  0470      AZE I
1102      1004  2776      ADD P40 /IF 0, MAKE 40
1103      1005  1420      SHD I          /IF STRT OF NEW FIELD, IGNORE
1104      1006  7400      7400
1105      1007  7002      JMP SHOVEA
1106      1010  1367      STH I 7
1107      1011  0226      XSK I 6
1110      1012  7002      JMP SHOVEA
1111      1013  6000      SHOVER, RETURN
1112
1113
1114
1115      1014  1040      LEGAL, STA
1116      1015  1031      LEGAL1
1117      1016  0017      COM
1120      1017  1106      ADA 6
1121      1020  0471      APO I
1122      1021  6000      JMP 0 /IF MIN=NUM=+, ERROR
1123      1022  1026      LDA I 6 /MAX
1124      1023  0017      COM
1125      1024  3031      ADD LEGAL1 /NUM-MAX=+,ERROR
1126      1025  0471      APO I
1127      1026  6000      JMP 0 /ELSE BUMP, RETURN, IN AC
1130      1027  0220      XSK I 0
1131      1030  1020      LDA I /RESTORE AC
1132      1031  0000      LEGAL1, 0
1133      1032  6000      JMP 0
1134
1135      1033  0000      LFUNIT, 0 /UNIT NUM
1136      1034  0017      17
1137      1035  0001      SHOW3, 1 /CHOICES
1140      1036  0004      4
1141      1037  0061      SHOW12, 61 /NUM PARA=SHOW31,
1142      1040  0062      62
1143      1041  0000      SHOW14, 0 /BLOCK NUM RAW DATA
1144      1042  0777      777
1145      1043  1001      1001 /NUM PTS
1146      1044  3770      3770
1147      1045  0000      SHW21M, 0 /NUM MISSES
1150      1046  0277      277
1151      1047  0001      SHOW41, 1
1152      1050  0003      3
1153
1154      1051  0000      STTAB, 0
1155      1052  7157      JMP STDOR /JUMP GENERATE CURVE
1156      1053  7334      JMP STPRT /JUMP PRINT
1157      1054  7433      JMP STERR /JUMP ERASE
1160      1055  7470      JMP STDIAL /JUMP START DIAL
1161
1162      /MAINLINE CODING, DIAL MS I/O READIN
1163      /PROCESS DATA FROM EARLY DISPLAYS
1164      /TEXT BUFFER IS BY LOC 1365=CALL BUFB4
1164      1056  1020      B4INTB, LDA I /SUB TO INIT ANS BUFF
1165      1057  2400      BUFB4 + 2000
1166      1060  0645      LOF 5
1167      1061  1040      STA
1170      1062  2022      ANSWER + 2000 /SET UP ANS BUFF
1171      1063  0067      SET I 7
1172      1064  7775      7775
1173      1065  6000      JMP 0
1174      1066  7056      STRT, JMP B4INTB
1175      1067  1020      LDA I
1176      1070  0026      DSP1
1177      1071  0067      SET I 7

```

1200	1072	7774	7774
1201	1073	0016	NOP
1202	1074	6747	JMP HELPDS /GET NUM IN AC
1203	1075	0066	SET I 6
1204	1076	1033	LFUNIT
1205	1077	7014	JMP LEGAL
1206	1100	6764	JMP MNLNER /NOT 1-17, ERROR, TRY AGAIN
1207			/LIFE TAPE UNIT NUM IN AC
1210	1101	1040	STRTA, STA
1211	1102	0044	PARA0
1212	1103	4073	STC PARA /STORE IN TAPE PARA
1213	1104	6053	JMP DOSUB
1214	1105	6150	JMP RDTAPE /READ BLK 0 INTO QUARTER 1,87
1215			/SET UP FOR CHECKING
1216	1106	6107	JMP CKTPIN /INITIALIZE
1217	1107	6116	JMP CKTP /DO CHECK
1220	1110	0456	SKP
1221	1111	7127	JMP STRTB
1222			/NOT INITIALIZED LIFE TAPE
1223	1112	1020	STRT2, LDA I
1224	1113	0053	DSP2
1225	1114	6053	JMP DOSUB
1226	1115	7237	JMP GETANS /ANSWER IN BUFB4
1227	1116	1000	LDA
1230	1117	0400	BUFB4
1231	1120	1460	SAE I
1232	1121	7431	7431 /INITIALIZE LIFE TAPE
1233	1122	7066	JMP STRT /ANY ANSWER BUT YES, START OVER
1234	1123	6131	JMP INTP /INITIALIZE LIFE TAPE IF YES
1235	1124	0011	CLR
1236	1125	6053	JMP DOSUB
1237	1126	6173	JMP WTTAPE /WRITE OUT BLOCK 0 ON LIFE TAPE UNIT
1240			/READ LIFE BLOCK 0 INTO Q0B7
1241			/LIFE TAPE INITIALIZED
1242	1127	0002	STRTB, PDP
1243			PMODE
1244	1130	6211	CDF 10
1245	1131	6212	CIF 10
1246	1132	4442	JMS I PREAD
1247	1133	0044	PARA0
1250	1134	6141	LINC
1251			LMODE
1252			/DO CHOICE OPTIONS
1253	1135	1020	STRTC, LDA I
1254	1136	0102	DSP3
1255	1137	0067	SET I 7
1256	1140	7775	7775
1257	1141	6747	JMP HELPDS /GET OCTAL NUM IN AC
1260	1142	0066	SET I 6
1261	1143	1035	SHOW3
1262	1144	7014	JMP LEGAL
1263	1145	6764	JMP MNLNER /NOT 1-4, ERROR, TRY AGAIN
1264	1146	1120	ADA I
1265	1147	7051	STTAB+6000
1266	1150	4006	STC 6
1267	1151	6006	JMP 6
1270			/SETUP SHOVE ROUTINE
1271	1152	0066	SETSHV, SET I 6 /BUFB4, 4 CHAR
1272	1153	7773	7773
1273	1154	0065	SET I 5
1274	1155	0400	BUFB4
1275	1156	6000	JMP 0
1276	1157	7161	STDOR, JMP IPCSUB /START DORETTE

1277	1160	7201	JMP STDORZ	/GET INSTRUMENT NAME
1300	1161	1000	IPCSUB, LDA	
1301	1162	0000	0	
1302	1163	5200	STC IPCRT	/SUB TO SAVE INST NAME
1303	1164	1020	LDA I	
1304	1165	0167	DSP1P1	
1305	1166	6053	JMP DOSUB	
1306	1167	7237	JMP GETANS	/4 CHAR NAME IN BUFB4
1307	1170	7152	JMP SETSHV	
1310	1171	0067	SET I 7	/TRANSFER TO INSTNM
1311	1172	4100	INSTNM+3777	
1312	1173	6777	JMP SHOVE	
1313	1174	0067	SET I 7	
1314	1175	5553	TY08A+3777	
1315	1176	7152	JMP SETSHV	
1316	1177	6777	JMP SHOVE	
1317	1200	6000	IPCRT, RETURN	
1320			/CHECK IF NEW INSTRUMENT	
1321	1201	6242	STDORZ, JMP ER0	
1322	1202	7237	JMP STDOR5	/NO
1323	1203	0016	NOP	
1324			/YES, GET NUM PAR	
1325	1204	1020	STDOR3, LDA I	
1326	1205	0201	DSP1P2	
1327	1206	6053	JMP DOSUB	
1330	1207	7237	JMP GETANS	/ANSWER IN BUFB4
1331	1210	1000	LDA	
1332	1211	0400	BUFB4	
1333	1212	1460	SAE I	
1334	1213	7431	7431	
1335	1214	7157	JMP STDOR	/IF NEW INST, NOT ACCEPTED, ASK AGAIN
1336	1215	1000	LDA	
1337	1216	0401	BUFB4+1	
1340	1217	1560	BCL I	
1341	1220	7700	7700	/LEAVE 006 NUM IN AC
1342	1221	0066	SET I 6	
1343	1222	1037	SHOW12	
1344	1223	7014	JMP LEGAL	/IS NUM PAR FROM 1-2
1345	1224	7204	JMP STDOR3	/NO, REFUSE INFORMATION
1346	1225	1560	STDOR4, BCL I	
1347	1226	7774	7774	/GET NUM PAR IN AC
1350	1227	0646	LDF 6	
1351	1230	1040	STA	
1352	1231	2047	PRMTRS+2000	
1353	1232	0640	LDF 0	
1354	1233	1040	STA	
1355	1234	2027	NUMPRA+2000	
1356	1235	4100	STC NUMPAR	/STORE IN ALL BANKS
1357	1236	7237	JMP STDOR5	
1360			/NOT NEW INSTRUMENT, GET NUM PAR IN AC	
1361			/GET TAPE NAME, SPECTRUM NAME	
1362	1237	1020	STDOR5, LDA I	
1363	1240	0246	DSP1P3	
1364	1241	6053	JMP DOSUB	
1365	1242	7237	JMP GETANS	/GET ANS BUFF IN BUFB4
1366	1243	7152	JMP SETSHV	
1367	1244	0067	SET I 7	
1370	1245	4047	NAMETP+3777	
1371	1246	6777	JMP SHOVE	/STORE TAPE NAME
1372	1247	7251	JMP SHVSB1	
1373	1250	7260	JMP STDORX	
1374	1251	0066	SHVSB1, SET I 6	/SET UP 16 CHAR SPEC TRANSFER
1375	1252	7757	7757	

1376	1253	0065	SET I 5
1377	1254	4402	BUFB4+4002
1400	1255	0067	SET I 7
1401	1256	5531	TY07A+3777
1402	1257	6000	JMP 0 /STORE SPECTRUM NAME
1403	1260	6777	STDORX, JMP SHOVE
1404			/GET START BLK, UNIT NUM, NUM PTS
1405	1261	1020	STDOR6, LDA I
1406	1262	0275	DSP1P4
1407	1263	0067	SET I 7
1410	1264	7774	7774
1411	1265	6747	JMP HELPDS /GET UNIT NUM IN AC
1412	1266	0066	SET I 6
1413	1267	1033	LFUNIT
1414	1270	7014	JMP LEGAL
1415	1271	6764	JMP MNLNER /NOT CORRECT, ERROR, TRY AGAIN
1416			/START BLK NUM IN AC
1417	1272	0640	LDF 0
1420	1273	1040	STA
1421	1274	2020	PARDAT+2000 /STORE IN DATA TAPE
1422			/HELP1 ALREADY SET UP, SO BMULT CAN BE USED
1423	1275	0067	SET I 7
1424	1276	7773	7773 /SET 3 DIGITS
1425	1277	0066	SET I 6
1426	1300	6401	BUFB4+6001
1427	1301	0011	CLR
1430	1302	0017	COM /MAKE OCTAL CONVERSION-START BLK
1431	1303	6053	JMP DOSUB
1432	1304	7310	JMP BMULT /ANS IN OCTAL, IN AC, 0=777 IS LEGAL
1433	1305	0640	LDF 0
1434	1306	1040	STA
1435	1307	2022	PARDAT+2002 /STORE FOR DATA TAPE
1436			/GET NUMPTS=DECIMAL
1437	1310	0067	SET I 7
1440	1311	7772	7772 /4 DIGITS MAX
1441	1312	0066	SET I 6
1442	1313	6403	BUFB4+6003
1443	1314	0011	CLR
1444	1315	6053	JMP DOSUB
1445	1316	7310	JMP BMULT /GET DECIMAL NUM PTS IN AC
1446	1317	0066	SET I 6
1447	1320	1043	SHOW14+2
1450	1321	7014	JMP LEGAL
1451	1322	6764	JMP MNLNER /ERROR, TRY AGAIN
1452	1323	0640	LDF 0
1453	1324	1040	STA
1454	1325	2024	NUMPT0+2000 /STORE NUM DATA POINTS
1455	1326	0600	LIF 0 /START DORETTE
1456	1327	7106	JMP DORAGO
1457	1330	0000	PRTABL, 0
1460	1331	7350	JMP PRT1 /PRINT SPECTRA
1461	1332	7375	JMP PRT2 /PRINT LIBRARY SPECTRUM
1462	1333	7135	JMP STRIC /STOP, GO TO CHOICE OPTION
1463			/START PRINT ROUTINE-MAINLINE
1464	1334	7056	STPRT, JMP B4INTB /INIT ANS BUFF
1465	1335	1020	LDA I
1466	1336	0444	DSP3P1
1467	1337	6747	JMP HELPDS /NUM IN AC
1470	1340	0066	SET I 6
1471	1341	1047	SHOW41
1472	1342	7014	JMP LEGAL
1473	1343	6764	JMP MNLNER /ERROR TRY AGAIN
1474			/CHOICE IN AC

1475	1344	1120		ADA I	
1476	1345	7330		PRTABL+6000	
1477	1346	4006		STC 6	
1500	1347	6006		JMP 6	/JUMP TO CHOICE 1-3
1501	1350	6053	PRT1,	JMP DOSUB	/PRINT SPECTRA
1502	1351	6267		JMP TYA	
1503	1352	7135		JMP STRTC	/GO TO CHOICE OPTIONS
1504				/GET SINGLE SPECTRUM, STORE DATA	
1505	1353	1000	SINGL,	LDA	
1506	1354	0000		0	
1507	1355	5374		STC SIGR	
1510	1356	1020		LDA I	
1511	1357	0515		DSP3P2	
1512	1360	6053		JMP DOSUB	
1513	1361	7237		JMP GETANS	/GET NAME OF INST, SPEC IN BUF84
1514	1362	7251		JMP SHVSB1	/SET UP SPECTRUM STORE
1515	1363	6777		JMP SHOVE	
1516	1364	7152		JMP SETSHV	/SET 4 CHAR AT START BUFF
1517	1365	0067		SET I 7	
1520	1366	4100		INSTNM+3777	
1521	1367	6777		JMP SHOVE	/INST NAME STORED
1522			/STORE IN PRT BUFF		
1523	1370	7152		JMP SETSHV	
1524	1371	0067		SET I 7	
1525	1372	5553		TY08A+3777	
1526	1373	6777		JMP SHOVE	
1527	1374	6000	SIGR,	RETURN	
1530	1375	7353	PRT2,	JMP SINGL	/GET ALL DATA INTO BUFF
1531	1376	6351		JMP TYC	/PRINT REMAINDER
1532	1377	7135		JMP STRTC	/GO TO CHOICE DISPLAY
1533	1400	0243	TYAY1,	ROL 3	/SAVE TAPE BLK-OCTAL
1534	1401	4041		STC RTN	
1535	1402	0075		SET I 15	
1536	1403	5663		TYAN3D+3777	
1537	1404	0074		SET I 14	
1540	1405	7774		7774	
1541	1406	2041	TYAY2,	ADD RTN	
1542	1407	0243		ROL 3	
1543	1410	1040		STA	
1544	1411	0041		RTN	
1545	1412	1560		BCL I	
1546	1413	7770		7770	/GET NXT DIG
1547	1414	1120		ADA I	
1550	1415	0060		60	
1551	1416	1375		STH I 15	
1552	1417	0011		CLR	
1553	1420	0234		XSK I 14	
1554	1421	7406		JMP TYAY2	
1555	1422	0606		LIF 6	
1556	1423	6372		JMP TYAY5	
1557	1424	7056	QAA1,	JMP B4INTB	
1560	1425	7127		JMP STRTB	/CNTRL R REINITIALIZATION
1561	1426	0000	ERTABL,	0	
1562	1427	7447		JMP ERR1	/ERASE TAPE
1563	1430	7455		JMP ERR2	/ERASE INSTRUMENT
1564	1431	7463		JMP ERR3	/ERASE SPECTRUM
1565	1432	7135		JMP STRTC	/STOP, GO TO CHOICE OPTION
1566				/PROCESS ERROR DATA	
1567	1433	7056	STERR,	JMP B4INTB	/INIT ANS BUFF
1570	1434	1020		LDA I	
1571	1435	0560		DSP4P1	
1572	1436	6747		JMP HELPDS	
1573	1437	0066		SET I 6	

1574	1440	1035	SHOW3	
1575	1441	7014	JMP LEGAL	
1576	1442	6764	JMP MNLNER	/ERROR IN CHOICE, TRY AGAIN
1577			/CHOICE IN AC	
1600	1443	1120	ADA I	
1601	1444	7426	ERTABL+6000	
1602	1445	4006	STC 6	
1603	1446	6006	JMP 6	/JUMP TO CHOICE 1=4.
1604			/ERASE TAPE	
1605	1447	7501	ERR1, JMP ERRNW0	/CLR BLK0 IN B7Q1
1606	1450	6131	JMP INTP	
1607	1451	0011	CLR	
1610	1452	6053	JMP DOSUB	
1611	1453	6173	JMP WTTAPE	/WRITE IT OUT
1612	1454	7127	JMP STRTB	/GO TO REREAD LIFE TAPE
1613			/ERASE INDEX	
1614	1455	0016	ERR2, NOP	/SAVE INST NAME
1615	1456	7161	JMP IPCSUB	
1616	1457	6242	JMP ER0	
1617	1460	6261	JMP ER2	/MATCH, DELETE INST
1620	1461	0016	NOP	
1621	1462	7127	ERR2A, JMP STRTB	/NO MATCH, RETURN
1622			/DELETE INDIVIDUAL SPECTRA	
1623	1463	7353	ERR3, JMP SINGL	/GET INST, SPEC STORED
1624	1464	6415	JMP DELSP	/DELETE SPECTRUM
1625			/WRITE OUT BLK 0	
1626	1465	6053	JMP DOSUB	
1627	1466	7566	JMP WTUN0	
1630	1467	7127	JMP STRTB	/RETURN
1631			/START DIAL	
1632	1470	0002	STDIAL, PDP	
1633			PMODE	
1634	1471	5440	JMP I Z DIAL77	
1635			LMODE	
1636	1472	1020	NOMORE, LDA I	/MAY BE UNUSED
1637	1473	6165	6165	/ERR CD 5
1640	1474	6721	JMP X3	
1641			/PTR 1 SET, PRNT LINE	
1642	1475	6053	LBPR4, JMP DOSUB	
1643	1476	6112	JMP PRNTLN	/PRINT MATCH SPECTRUM LINE
1644	1477	0606	LIF 6	
1645	1500	7114	JMP LBPRX	/GET NXT SPECTRA
1646	1501	1000	ERRNW0, LDA	/ASK IF SURE
1647	1502	0000	0	
1650	1503	5514	STC ERRNW9	
1651	1504	1020	ERRNW1, LDA I	
1652	1505	1674	DSPNEW	
1653	1506	6053	JMP DOSUB	
1654	1507	7237	JMP GETANS	/GET Y OR N IN BUF84
1655	1510	7152	JMP SETSHV	
1656	1511	1325	LDH I 5	
1657	1512	1420	SHD I	
1660	1513	3100	3100	
1661	1514	6000	ERRNW9, RETURN	/IF Y GO ON
1662	1515	1420	SHD I	
1663	1516	1600	1600	
1664	1517	7433	JMP STERR	/IF N BACK TO ERASE DISP
1665	1520	7504	JMP ERRNW1	/ELSE RESHOW SURE
1666	1521	4040	4040	
1667	1522	4040	TY07, 4040	
1670	1523	2320		
1670	1524	0503		
1670	1525	2422		

1670	1526	2515		
1670	1527	4072		
1670			TEXT QSPECTRUM :Q	
1671	1530	4040	4040	
1672	1531	4040	4040	
1673	1532	4040	TY07A,	/ANSWER BUFFER
1674	1533	4040	4040	
1675	1534	4040	4040	
1676	1535	4040	4040	
1677	1536	4040	4040	
1700	1537	4040	4040	
1701	1540	4040	4040	
1702	1541	4040	4040	
1703	1542	0000	0000	
1704	1543	4040	TY08,	4040
1705	1544	4040	4040	
1706	1545	1116		
1706	1546	2324		
1706	1547	2225		
1706	1550	1505		
1706	1551	1624		
1706	1552	4072		
1706			TEXT QINSTRUMENT :Q	
1707	1553	4040	4040	
1710	1554	4040	TY08A,	/ANSWER BUFFER - USE AS FIRST LINE OF INDEX PRINTOUT
1711	1555	4040	4040	
1712	1556	0000	0000	
1713	1557	4040	TY09,	4040
1714	1560	4040	4040	
1715	1561	2013	2013	/PK
1716	1562	4040	4040	
1717	1563	4040	4040	
1720	1564	3040		
1720	1565	2601		
1720	1566	1440		
1720			TEXT QX VAL Q	
1721	1567	4040	4040	
1722	1570	0000	TY09A,	0 /0 HERE IF ONE PARA
1723	1571	4040	4040	
1724	1572	3140		
1724	1573	2601		
1724	1574	1440		
1724			TEXT QY VAL Q	
1725	1575	4040	4040	
1726	1576	0000	TY09B,	0 /0 HERE IF TWO PARA
1727	1577	4040	4040	
1730	1600	2001		
1730	1601	2201		
1730	1602	4063		
1730			TEXT QPARA 3Q	
1731	1603	0000	TY09C,	0000
1732	1604	4040	TYANS,	4040
1733	1605	4040	4040	
1734	1606	4040	TYAN1,	4040
1735	1607	4040	TYAN1A,	4040 /SPECTRUM NAME
1736	1610	4040	4040	
1737	1611	4040	4040	
1740	1612	4040	4040	
1741	1613	4040	4040	
1742	1614	4040	4040	
1743	1615	4040	4040	
1744	1616	4040	4040	
1745	1617	4040	4040	

1746	1620	4040	4040	
1747	1621	0000	0000	/PEAK PTS
1750	1622	4040	4040	
1751	1623	4040	4040	/Ø IF UNKNOWN LINE
1752	1624	4040	4040	
1753	1625	4040	4040	
1754	1626	4040	4040	
1755	1627	4040	4040	/MISSES
1756	1630	0000	0000	
1757	1631	0000	0000	
1760	1632	4040	4040	
1761	1633	4040	4040	
1762	1634	4040	4040	/INSTRUMENT NAME
1763	1635	4040	4040	
1764	1636	4040	4040	
1765	1637	4040	4040	
1766	1640	4040	4040	
1767	1641	4040	4040	
1770	1642	4040	4040	
1771	1643	0000	0	/SPECTRUM NAME
1772	1644	0000	0	
1773	1645	0000	0	
1774	1646	0000	0	
1775	1647	0000	0	
1776	1650	0000	0	
1777	1651	0000	0	
2000	1652	0000	0	
2001	1653	4040	4040	
2002	1654	4040	4040	
2003	1655	4040	4040	
2004	1656	0000	0	/TAPE NAME
2005	1657	0000	0	
2006	1660	4040	4040	
2007	1661	4040	4040	
2010	1662	4040	4040	
2011	1663	4040	4040	
2012	1664	0000	0	/ST BLK
2013	1665	0040	40	
2014	1666	4040	4040	
2015	1667	4040	4040	
2016	1670	4040	4040	
2017	1671	0000	0	/PTS - 4 DIGITS
2020	1672	0000	0	
2021	1673	0000	0	/END
2022	1674	4040	4040	
2023	1675	0000	0	/PEAK
2024	1676	0000	0	
2025	1677	4040	4040	
2026	1700	4040	4040	
2027	1701	4000	4000	/PARA1 - 3 DIGITS
2030	1702	0000	0	
2031	1703	4000	4000	/Ø IF ONLY 1 PARA
2032	1704	4040	4040	
2033	1705	4040	4040	
2034	1706	4040	4040	
2035	1707	4000	4000	/PARA 2 - 3 DIGITS
2036	1710	0000	0	
2037	1711	4040	4040	/Ø IF ONLY 2 PARA
2040	1712	4040	4040	
2041	1713	4040	4040	
2042	1714	4000	4000	/PARA 3 = 3 DIGITS
2043	1715	0000	0	
2044	1716	0000	0	/END OF LINE

2045	1717	4040	TY06,	4040
2046	1720	1116		
2046	1721	2324		
2046	1722	2225		
2046	1723	1505		
2046	1724	1624		
2046			TEXT QINSTRUMENTQ	
2047	1725	4040		4040
2050	1726	4040		4040
2051	1727	2320		
2051	1730	0503		
2051	1731	2422		
2051	1732	2515		
2051	1733	4016		
2051	1734	0115		
2051			TEXT QSPECTRUM NAMQ	
2052	1735	0540		0540
2053	1736	4040		4040
2054	1737	4040		4040
2055	1740	4040		4040
2056	1741	2401		
2056	1742	2005		
2056	1743	4016		
2056	1744	0115		
2056			TEXT QTAPE NAMQ	
2057	1745	0540		0540
2060	1746	4040		4040
2061	1747	2324		
2061	1750	0122		
2061	1751	2411		
2061	1752	1607		
2061	1753	4002		
2061	1754	1413		
2061			TEXT QSTARTING BLKQ	
2062	1755	4040		4040
2063	1756	2013		
2063	1757	2300		
2063			TEXT QPKSQ	
2064	1760	0000		0000
2065			CHAIN "LIFE B6"	

```

0000          *20
0001          /SUBROUTINE FIELD, DISPLAY IN LAST QRT
0002          SEGMENT 6
0003          *20
0004          /B6 SUBROUTINE CALLER CALLING BANK IN DATA FIELD
0005          RETURN=6000
0006          0020 4037 B6CALL, STC JMPSUB
0007          0021 0005          QAC
0010          0022 0452          LZE          /IS L=0
0011          0023 2051          ADD P4000      /NO, SET BIT 0
0012          0024 4036          STC ACVALZ      /SAVE AC
0013          0025 0500          IOB
0014          PMODE
0015          4026 6214          RDF          /GET DATA FIELD SET UP RETURN INSTR FIELD
0016          LMODE
0017          0027 0301          ROR 1
0020          0030 1120          ADA I
0021          0031 0600          LIF
0022          0032 4040          STC LIFX
0023          0033 2000          ADD 0
0024          0034 4041          STC          BXRET
0025          0035 1020          LDA I

```

```

0026      0036 0000 ACVALZ, 0          /RESTORE AC
0027      0037 0000 JMPSUB, 0
0030      0040 0000 LIFX, 0          /RETURN, EXIT
0031      0041 0000 BXRET, 0
0032
0033      0042 0212 LF, 212          /CONSTANTS, TEMP STOR, REF, FLAGS
0034      0043 0215 CR, 215
0035      0044 0100 P100, 100
0036      0045 4442 JMQR, 4400+PREAD
0037      0046 4443 JMQR, 4400+PWRITE
0040      0047 0000 PRMTRS, 0        /PARA IN CORR TAPE
0041      0050 0000 TEMP1, 0        /DECML
0042      0051 4000 P4000, 4000
0043      0052 0002 PLUS2, 2
0044      0053 0003 P3, 3
0045      0054 0001 P1, 1
0046      0055 4040 SPSP, 4040
0047      0056 0000 NUMPTS, 0      /NUMPTS IN PRINT SPECTROM
0050      0057 5400 KIDORA, IDORA
0051      0060 5544 KRORA, RDORA
0052
0053      0061 0046 INTDRA, SET 6
0054      0062 0000
0055      0063 0002 PDP
0056
0057      4064 6032 KCC /CLEAR KEYBOARD FLAG
0060      4065 4657 JMS I KIDORA
0061      4066 0000 DRSTRT, 0
0062      4067 2000 2000 /BEG CORE LOC
0063      4070 0000
0064      4071 0000 DREND, 0 /END CORE LOC
0065      4072 0000 YOFFST, 0
0066      4073 0341 YSCALE, 341 /SCR 1
0067      4074 5300 JMP ,+4
0070
0071      0075 0046 CLLORA, SET 6
0072      0076 0000
0073      0077 0002 PDP
0074
0075      4100 6032 KCC
0076      4101 4660 JMS I KRORA /REFRESH DORA
0077      4102 6031 KSF
0100      4103 5301 JMP ,=-2 /IF NO NEW CHAR, REFRESH DORA
0101      4104 6036 KRB /CHAR IN AC, KEYBOARD FLAG CLEAR
0102      4105 6041 TSF /PRINTER READY ?
0103      4106 5305 JMP ,=-1
0104      4107 6046 TLS /OUTPUT CHAR
0105      4110 6141 LINC
0106
0107      0111 6006 LMODE
0110
0111      0112 1000 PRNTLN, LDA
0112      0113 0000
0113      0114 4126 STC PRNTPC /SAVE RET
0114      0115 1321 PRNTLA, LDH I 1 /GET NEXT CHARACTER
0115      0116 0450 AZE
0116      0117 6127 JMP PRNTCH
0117      0120 2043 ADD CR /IF 0, PRINT LF,CR
0120      0121 6137 JMP GOPRT
0121      0122 0011 CLR
0122      0123 2042 ADD LF
0123      0124 6137 JMP GOPRT
0124      0125 0011 CLR

```

0125	0126	6000	PRNTPC,	RETURN	
0126				/TURN 6 BIT DATA INTO 12 BIT	
0127	0127	1120	PRNTCH,	ADA I	
0130	0130	7740		7740	
0131	0131	0451		APO	
0132	0132	2044		ADD P100	/LESS THAN 40. ADD 300
0133	0133	1120		ADA I	
0134	0134	0237		237	/ELSE ADD 200
0135	0135	6137		JMP GOPRT	/PROCESS
0136	0136	6115		JMP PRNTLA	
0137				/PRINT A CHARACTER IN AC	
0140	0137	0500	GOPRT,	IOB	
0141	0140	6046		GATLS	/TLS
0142	0141	1000		LDA	
0143	0142	0000		0	
0144	0143	4147		STC ,+4	
0145	0144	0500		IOB	
0146	0145	6041		GATSF	/TSF
0147	0146	6144		JMP ,-2	
0150	0147	6000		RETURN	
0151				/SUBROUTINE TO READ, BLOCK TAPE IN AC	
0152				/INTO B7Q1, FROM PARA IN B4	
0153	0150	4172	RDTAPE,	STC RWTAPE	
0154	0151	2045		ADD JMQR	/TAPE READ
0155	0152	4164		STC TAPEZ1	
0156	0153	2000		ADD 0	
0157	0154	4171		STC RDTPT	
0160	0155	0644	TAPEZ,	LDF 4	
0161	0156	1000		LDA	
0162	0157	0172		RWTAPE	
0163	0160	1040		STA	
0164	0161	2075		PARA+2002	
0165	0162	0002		PDP	
0166				Pmode	
0167	4163	6211		CDF 10	
0170	4164	4442	TAPEZ1,	JMS I PREAD	
0171	4165	0073		PARA	
0172	4166	6141		LINC	
0173				Lmode	
0174	0167	0647		LDF 7	
0175	0170	0011		CLR	
0176	0171	6000	RDTPT,	RETURN	
0177	0172	0000	RWTAPE,	0	/STORE PARA 2
0200				/SUBROUTINE TO WRITE 1 BLK TAPE IN AC	
0201				/INTO B7 QV FROM PARA IN B4	
0202	0173	4172	WTTAPE,	STC RWTAPE	
0203	0174	2046		ADD JMQW	/TAPE WRITE
0204	0175	4164		STC TAPEZ1	
0205	0176	2000		ADD 0	
0206	0177	4171		STC RDTPT	
0207	0200	6155		JMP TAPEZ	
0210				/SUBROUTINE TO PRINT LF, CR	
0211				/LINES IN AC	
0212	0201	0017	PRLF,	COM	
0213	0202	4001		STC 1	
0214	0203	2000		ADD 0	
0215	0204	4216		STC PRLFRT	
0216	0205	0011	PRLFA,	CLR	
0217	0206	2043		ADD CR	
0220	0207	6137		JMP GOPRT	
0221	0210	0221		XSK I 1	
0222	0211	6205		JMP PRLFA	
0223	0212	0011		CLR	

```

0224      0213  2042          ADD LF
0225      0214  6137          JMP GOPRT
0226      0215  0011          CLR
0227      0216  6000  PRLFRT, RETURN
0230                      /SUBSUB TO STORE- WDS IN PTR15
0231                      /FROM DATA FIELD IN PTR 16 LDF 7
0232                      /TO DATA FIELD -1 IN PTR 17 LDF 1
0233                      /IF PAST BLOCK, READ IN NEW BLK
0234      0217  1000  TRNSMD, LDA          /SET UP TRNXFER FROM B4
0235      0220  0000          0
0236      0221  4227          STC TRNSMT
0237      0222  2344          ADD Z7          /LDF 4
0240      0223  4235          STC TRNMD1
0241      0224  6230          JMP TRANS          /OO TRANSFER
0242      0225  2271          ADD TRNMD2
0243      0226  4235          STC TRNMD1          /RESTORE LDF5
0244      0227  6000  TRNSMT, RETURN
0245      0230  1000  TRANS, LDA
0246      0231  0000          0
0247      0232  4243          STC TRNSRT
0250      0233  0647  TRANSA, LDF 7          /GET NEXT LIFE BLOCK WD
0251      0234  1016          LDA 16
0252      0235  0645  TRNMD1, LDF 5
0253      0236  1077          STA I 17
0254      0237  6244          JMP TRANSB
0255      0240  0235          XSK I 15          /HAS BLOCK ENDED
0256      0241  6234          JMP TRANSA+1          /YES, INIT, READ NEXT
0257      0242  0011          CLR
0260      0243  6000  TRNSRT, RETURN
0261                      /PRT 16 MUST BE ADVANCED, READ IN NEW BLOCK IF NECC,
0262                      / PTR 16 IS LIFE BLOCK PTR B7Q1
0263      0244  1000  TRANSB, LDA
0264      0245  0000          0
0265      0246  4266          STC TRABRT
0266      0247  0647          LDF 7
0267      0250  0236          XSK I 16
0270      0251  2016          ADD 16
0271      0252  1460          SAE I
0272      0253  2777          2777
0273      0254  6265          JMP TRABRT-1
0274                      /WRITE OLD BLK
0275      0255  0644          LDF 4
0276      0256  1000          LDA
0277      0257  2075          PARA+2002
0300      0260  6173          JMP WTTAPE
0301      0261  1016          LDA 16          /READ NEW BLOCK
0302      0262  6150          JMP RDTAPE
0303      0263  0076          SET I 16
0304      0264  2400          2400
0305      0265  1016          LDA 16
0306      0266  6000  TRABRT, RETURN
0307                      /SUBROUTINE TO PRINT INDEX SPECTRA
0310                      /PTRS 10,11,12-1,15,16,17 USED IN SUBSUB
0311                      /B0 ASSUMED IN B7Q0
0312      0267  0050  TYA,          SET 10
0313      0270  0000          0
0314      0271  0645  TRNMD2, LDF 5          /CNST IN TRNMD
0315      0272  1020          LDA I
0316      0273  0003          3
0317      0274  6201          JMP PRLF          /PRINT 3 LF
0320      0275  0061          SET I 1
0321      0276  6751          TYO>+5777
0322      0277  6112          JMP PRNTLN          /PRINT INDEX

```

0323	0300	2052		ADD PLUS2	
0324	0301	6201		JMP PRLF	/PRINT 2 LF
0325	0302	0644		LDF 4	
0326	0303	0061		SET I 1	
0327	0304	7716		TY06+5777	
0330	0305	6112		JMP PRNTLN	/PRINT INST, SPEC, TP, STBLK, PTS
0331	0306	2054		ADD P1	
0332	0307	6201		JMP PRLF	/PRINT 1 LF
0333				/START OF DATA PROC FOR SUB COLUMNS	
0334	0310	0647	TYA1,	LDF 7	
0335	0311	0071		SET I 11	/PTR 11 IS INDEX PTR-AT FRST BLK OF LAST INST
0336	0312	2007		2007	
0337	0313	1031	TYA2,	LDA I 11	
0340	0314	0450		AZE	
0341	0315	6323		JMP TYA3	
0342	0316	0471		APO I	
0343	0317	6010		JMP 10	/IF NEXT ENTRY=0, PRINTOUT OVER
0344	0320	0231		XSK I 11	
0345	0321	0231		XSK I 11	
0346	0322	6313		JMP TYA2	/IF ENTRY=7777, DELETED, SKIP
0347	0323	0056	TYA3,	SET I 16	/SET UP INST DATA FIELD PTR
0350	0324	0011		11	
0351	0325	0075		SET I 15	/4 CHAR=2WDS
0352	0326	7775		7775	
0353	0327	0077		SET I 17	
0354	0330	3633		TYANA+1777	
0355	0331	6217		JMP TRNSMD	/TRNS INTO INST LN
0356				/GET SPECTUM DATA	
0357	0332	0647		LDF 7	
0360	0333	0231		XSK I 11	
0361	0334	1031		LDA I 11	/FIRST BLK IN AC
0362	0335	0242		ROL 2	
0363	0336	1560		BCL I	
0364	0337	7774		7774	
0365	0340	4047		STC PRMTRS	/GET PARA
0366	0341	1011		LDA 11	
0367	0342	1560		BCL I	/CLEAR PARA FROM TAPE BITS
0370	0343	6000		6000	
0371	0344	0644	Z7,	LDF 4	
0372	0345	1040		STA	
0373	0346	2103		FSTBLK+2000	
0374	0347	6150		JMP RDTAPE	/READ IN FIRST DATA BLOCK
0375				/GET SPECTRUM LINE	
0376	0350	6616		JMP SET16	/INITIALIZE, STORE
0377	0351	0236		XSK I 16	
0400	0352	6357		JMP TYA4A	
0401	0353	6244	TYA4,	JMP TRANSB	/START OF SPEC DATA
0402	0354	0470		AZE I	
0403	0355	6313		JMP TYA2	/IF=0, GET NEW INST
0404	0356	6620		JMP SET16+2	/NO, PROC NEW ANS
0405	0357	6217	TYA4A,	JMP TRNSMD	/TRANS SPEC DATA
0406	0360	1016		LDA 16	/FST TAPE WD,0 IF DEL
0407	0361	0450		AZE	
0410	0362	6404		JMP TYAZ	
0411	0363	6244		JMP TRANSB	/DELETED SPECTRA, GET PAST
0412	0364	6244		JMP TRANSB	
0413	0365	6244		JMP TRANSB	/TO NUMPTS
0414	0366	6402		JMP TYAX	/TO START OF NEXT SPECTRUM
0415	0367	6244	TYAY,	JMP TRANSB	/GET STBLK
0416	0370	0604		LIF 4	
0417	0371	7400		JMP TYAY1	/GET OCTAL
0420	0372	6244	TYAY5,	JMP TRANSB	/GET PTS
0421	0373	0077		SET I 17	

0422	0374	3670		TYAN3E+1777	
0423	0375	0644		LDF 4	
0424	0376	6430		JMP DECML	/PROCESS INTO 4 DIG, COMPL LINE
0425	0377	0061		SET I 1	
0426	0400	7631		TYAN3+5777	
0427	0401	6112		JMP PRNTLN	/OUTPUT SPECTRUM LINE
0430	0402	6635	TYAX,	JMP ADV16	/MOVE PTR 16 FROM PARA TO FIRST
0431	0403	6353		JMP TYA4	
0432				/GET PAST TAPE NAME, STORE	
0433	0404	0644	TYAZ,	LDF 4	
0434	0405	1040		STA	
0435	0406	3656		TYAN3C+2000	
0436	0407	6244		JMP TRANSB	
0437	0410	0644		LDF 4	
0440	0411	1040		STA	
0441	0412	3657		TYAN3C+2001	
0442	0413	6367		JMP TYAY	
0443				/SUBROUTINE STORES WD IN AC AS 4 DEC ASC DIGITS	
0444				/IN BUFF LOCATED BY PTR 17. PTRS 13,14,2	
0445	0414	0017	DECMRM,	COM	
0446	0415	4050		STC TEMP1	/GET + VAL
0447	0416	1020		LDA I	
0450	0417	0055		55	
0451	0420	1357	V4,	STH 17	
0452	0421	0011		CLR	
0453	0422	2050		ADD TEMP1	/RESTORE AC
0454	0423	6446		JMP DECMLA	
0455	0424	6027	M1THS,	6027	
0456	0425	7633	M100,	7633	
0457	0426	7765	M10,	7765	
0460	0427	7776	M1,	7776	
0461	0430	4050	DECML,	STC TEMP1	
0462	0431	2000		ADD 0	
0463	0432	4463		STC DECMRT	
0464	0433	4014		STC 14	/CLEAR DIGIT VALUE
0465	0434	0073		SET I 13	
0466	0435	7773		7773	/SET DIGIT CNT
0467	0436	0072		SET I 12	
0470	0437	0424		M1THS	/INIT PLACE PTR
0471	0440	2050		ADD TEMP1	/RESTORE AC
0472	0441	0451		APO	/IS VAL =
0473	0442	6414		JMP DECMRM	
0474	0443	1020		LDA I	
0475	0444	0040		40	
0476	0445	6420		JMP V4	/NO STORE SP
0477	0446	1112	DECMLA,	ADA 12	
0500	0447	0470		AZE I	
0501	0450	6455		JMP DECMLB	/IF NEXT ADD 0, PROCESS
0502	0451	0451		APO	
0503	0452	6466		JMP DECMLC	/IF NEG, RESET
0504	0453	0234		XSK I 14	/IF +, BUMP DIGIT VALUE
0505	0454	6446		JMP DECMLA	
0506	0455	0234	DECMLB,	XSK I 14	/0 SEEN, TERMINATE
0507	0456	2014		ADD 14	
0510	0457	6504		JMP M1S	/ADD VALUE TO 60, STORE IN PTR 17
0511	0460	0060		60	
0512	0461	0233		XSK I 13	/IS IT LAST DIGIT
0513	0462	0456		SKP	
0514	0463	6000	DECMRT,	RETURN	
0515	0464	4014		STC 14	/RECLEAR DIGIT CNT
0516	0465	6456		JMP DECMLB+1	/FILL WITH 0
0517	0466	0017	DECMLC,	COM	/NEG, RESTORE VALUE
0520	0467	1112		ADA 12	

0521	0470	0017		COM
0522	0471	4050		STC TEMP1
0523	0472	2014		ADD 14
0524	0473	6504		JMP M1S /WRITE IT
0525	0474	0060		60
0526	0475	4014		STC 14
0527	0476	2050		ADD TEMP1
0530	0477	0232		XSK I 12 /SET TO NEXT DIGIT
0531	0500	0233		XSK I 13 /OVER
0532	0501	6446		JMP DECMLA /NO, GET MORE
0533	0502	0011		CLR
0534	0503	6463		JMP DECMRT /YES, RETURN
0535				/SUBROUTINE PUTS 6 BIT ASC IN HALF WD OF PTR 17
0536	0504	4514	M1S,	STC M1A
0537	0505	2000		ADD 0
0540	0506	1560		BCL I
0541	0507	6000		6000
0542	0510	4002		STC 2 /PTR 2 HAS NEXT LOC
0543	0511	0220		XSK I 0
0544	0512	1002		LDA 2
0545	0513	1120		ADA I
0546	0514	0000	M1A,	0 /ADDED TO AC
0547	0515	1377		STH I 17 /STORE HALF WD
0550	0516	0011		CLR
0551	0517	6000		JMP 0
0552				EJECT

```

0553 /SUBROUTINE TO PRINT SPECTRUM POINTS HEADER, SET COMPUTE LINE
0554 /PTRS 10,11,12=1,15,16,17 USED IN SUBSUB
0555 /B0 ASSUMED IN B700
0556 /SPECTRUM NAME, INSTRUMENT ALREADY STORED FROM DSP
0557 /PRMTRS CONTAINS PARA
0560 0520 4526 X12, STC X32
0561 0521 1031 LDA I 11
0562 0522 4524 STC X22 /SAVE LOC
0563 0523 0072 SET I 12
0564 0524 0000 X22, 0 /12 REACHES BUF
0565 0525 1020 LDA I
0566 0526 0000 X32, 0
0567 0527 1052 STA 12
0570 0530 6000 JMP 0
0571 0531 0050 TYB, SET 10
0572 0532 0000 0
0573 0533 0644 LDF 4
0574 0534 1020 LDA I
0575 0535 0003 3
0576 0536 6201 JMP PRLF /PRINT 3 LF
0577 0537 0061 SET I 1
0600 0540 7521 TY07+5777
0601 0541 6112 JMP PRNTLN /PRINT SPECTRUM
0602 0542 2052 ADD PLUS2
0603 0543 6201 JMP PRLF /PRINT 2 LF
0604 0544 0061 SET I 1
0605 0545 7542 TY08+5777 /PRINT INSTRUMENT
0606 0546 6112 JMP PRNTLN
0607 0547 2052 ADD PLUS2
0610 0550 6201 JMP PRLF /PRINT 2 LF
0611 0551 2047 ADD PRMTRS
0612 0552 0017 COM
0613 0553 4001 STC 1 /SET 1=:PARA
0614 0554 0071 SET I 11
0615 0555 0572 TYB1=1
0616 0556 0221 TYB2, XSK I 1 /IS THERE MORE PARA
0617 0557 2055 ADD SPSP /IF YES, INSERT SPACES
0620 0560 6520 JMP X12
0621 0561 6520 JMP X12 /NO, STORE TERM 0
0622 0562 0011 CLR
0623 0563 0201 XSK 1 /IS IT OVER
0624 0564 6556 JMP TYB2 /NO. STORE MORE 40S
0625 /YES PRINT LINE
0626 0565 0061 SET I 1
0627 0566 7556 TY09+5777
0630 0567 6112 JMP PRNTLN
0631 0570 2052 ADD PLUS2
0632 0571 6201 JMP PRLF /PRINT 2 LF
0633 0572 6010 JMP 10 /RETURN
0634 /PARAMETER COUNT TABLE
0635 0573 3570 TYB1, TY09A+2000
0636 0574 3703 TYAN4B+2000
0637 0575 3576 TY09B+2000
0640 0576 3711 TYAN4C+2000
0641 0577 3603 TY09C+2000
0642 0600 3716 TYAN4D+2000
0643 /SUBSUB TO COMPARE BUFFERS=1 IN PTR 6,7
0644 /WDS IN PTR 10
0645 /IF YES, 0, IF NO 4000
0646 0601 1000 COMPR, LDA
0647 0602 0000 0
0650 0603 4612 STC COMPRT /SAVE RET
0651 0604 1026 COMPR1, LDA I 6 /COMPARE

```

-

```

0652      0605 1467      SAE I 7
0653      0606 6613      JMP COMPR2
0654      0607 0230      XSK I 10      /YES, END
0655      0610 6604      JMP COMPR1
0656      0611 0011      CLR      /YES, OUT WITH 0 IN AC
0657      0612 6000      COMPRT, RETURN
0660      0613 1020      COMPR2, LDA I /NO COMPARE
0661      0614 7777
0662      0615 6612      JMP COMPRT      /EXIT, 4000 IN AC
0663      0616 0076      SET16, SET I 16      /SET UP FOR SEARCH LIFB DATA PTR 16-SUB
0664      0617 2401      2401
0665      0620 0647      LDF 7
0666      0621 0077      SET I 17
0667      0622 3642      TYAN3B+1777
0670      0623 0075      SET I 15
0671      0624 7767      7767
0672      0625 6000      JMP 0
0673      0626 4015      MV16, STC 15 /MOVE 16 =LOC IN AC
0674      0627 2000      ADD 0
0675      0630 4634      STC MVRT
0676      0631 6244      MV16A, JMP TRANSB
0677      0632 0235      XSK I 15
0700      0633 6631      JMP MV16A
0701      0634 6000      MVRT, RETURN
0702      /SUBROUTINE TO CALCULATE PTS IN PTR 16
0703      /X PARAMETERS IN PRMTRS
0704      /AND ADVANCE PTR 16 THAT MANY
0705      /PTR 16 AT NUM PTS,BNDS IN FIRST WD OF NEXT SPECTRUM
0706      0635 0647      ADV16, LDF 7
0707      0636 1000      LDA
0710      0637 0047      PRMTRS
0711      0640 0017      COM
0712      0641 4015      STC 15 /SET 15 TO -PAR
0713      0642 2000      ADD 0
0714      0643 4654      STC ADVRT      /SAVE RET
0715      0644 1116      ADV16A, ADA 16 /GET PTS X PARA
0716      0645 0235      XSK I 15
0717      0646 6644      JMP ADV16A
0720      0647 0017      COM
0721      0650 4015      STC 15 /STORE NEG IN 15
0722      0651 6244      ADV16B, JMP TRANSB /MOVE PTR 16 PAST PARA
0723      0652 0235      XSK I 15
0724      0653 6651      JMP ADV16B
0725      0654 6000      ADVRT, RETURN
0726      /B6 PART OF B4 SUB FST BLK, AC CONT INIT BLK
0727      0655 6661      TYC1, JMP TYCSB      /FIND SPECTRA
0730      0656 6735      JMP TYCNT      /CONTINUE
0731      0657 0604      LIF 4 /NO MATCH, EXIT
0732      0660 6005      JMP 5
0733      /SUBROUTINE TO FIND SPECTRUM
0734      /PTR 16 WILL BE AT NUMPTS, INIT BLK IN AC
0735      /SPECTRUM NAME IN TY07A IN B5
0736      /IF NO MATCH, BUMP RETURN, PTRS6,7,10
0737      0661 4665      TYCSB, STC TYCSB1
0740      0662 2000      ADD 0
0741      0663 4726      STC RETTY      /SAVE RET
0742      0664 1020      LDA I
0743      0665 0000      TYCSB1, 0 /INIT BLK NUM
0744      0666 6150      JMP RDTAPE      /READ IN LIFE TAPE BLOCK
0745      0667 6616      JMP SET16      /SET UP FOR SPECTRUM READ
0746      0670 6244      JMP TRANSB      /PUT SPECTRUM NAME IN B4 TYAN3B
0747      0671 6217      TYC1A, JMP TRNSMD
0750      /PTR16 STILL AT LAST SPECTRUM LOC

```

```

0751                                /SET UP COMPARE
0752      0672 1016      LDA 16          /IS SPEC DEL
0753      0673 0470      AZE I
0754      0674 6711      JMP TYC1N
0755      0675 0644      TYC1M, LDF 4
0756      0676 0066      SET I 6
0757      0677 3642      TYAN3B+1777
0760      0700 0067      SET I 7
0761      0701 3531      TYO7A+1777
0762      0702 0070      SET I 10
0763      0703 7767      7767
0764      0704 6601      JMP COMPR          /DO COMPARE
0765      0705 0451      APO              /IF + AC MATCH
0766                                /ONLY NOW PRINT HEADER
0767      0706 6711      JMP TYC1N
0770      0707 6531      TYC1X, JMP TYB          /DO PRINT OF HEAD
0771      0710 6727      JMP TYC2
0772                                /NO MATCH GET NEXT SPECTRA, TRY AGAIN
0773                                /FIRST MOVE PTR 16 TO START OF NEXT SPECTRA FROM END OF THIS
0774      0711 1020      TYC1N, LDA I
0775      0712 7774      7774
0776      0713 6626      JMP MV16          /GET TO NUM PTS LOCATION WITH PTR 16
0777      0714 6635      JMP ADV16        /GET TO LAST LOCATION OF OLD SPECTRA
1000      0715 6244      JMP TRANSB
1001      0716 0470      AZE I
1002      0717 6722      JMP TYC1B
1003      0720 6620      JMP SET16+2      /IF MORE SPECTRA, PROCESS
1004      0721 6671      JMP TYC1A
1005                                /IF NO MORE SPECTRA
1006      0722 1020      TYC1B, LDA I
1007      0723 0001      1          /BUMP RET
1010      0724 2726      ADD RETTY
1011      0725 4726      STC RETTY
1012      0726 6000      RETTY, RETURN
1013                                /MATCH, PRINT VALUES, PTR 16 AT FRST WD OF TSTNAME
1014      0727 0016      TYC2, NOP          /RESET BY DELSPEC ROUTINE
1015      0730 1020      LDA I
1016      0731 7774      7774
1017      0732 6626      JMP MV16          /GET TO NUM PTS
1020      0733 4056      STC NUMPTS      /SAVE
1021      0734 6726      JMP RETTY        /RETURN
1022                                /PRINT SUB CONTINUED
1023      0735 4011      TYCNT, STC 11   /INIT LINE NUM
1024      0736 2056      TYC1C, ADD      NUMPTS
1025      0737 0470      AZE I
1026      0740 7005      JMP V1          /IF NO PTS,NO PRINT
1027      0741 0017      COM
1030      0742 4010      STC 10        /SAVE - NUMPTS
1031      0743 2047      TYC1D, ADD PRMTRS
1032      0744 0017      COM
1033      0745 4007      STC 7         /INIT - NUM PARA
1034      0746 0066      TYC1E, SET I 6
1035      0747 0574      TYB1+1
1036      0750 0231      XSK I 11       /STORE NEW LINE NUM
1037      0751 1000      LDA
1040      0752 0011      11
1041      0753 0077      SET I 17
1042      0754 7674      TYAN4A+5777
1043      0755 0644      LDF 4
1044      0756 6430      JMP DECML
1045      0757 2055      ADD SPSP
1046      0760 1040      STA
1047      0761 3675      TYAN4A+2000   /LINE NUM SHOULD BE ONLY 2 DIG

```

```

1050                                     /PROCESS NEXT POINT
1051      0762 1020 TYC1F, LDA I
1052      0763 3775          3775
1053      0764 1106          ADA 6
1054      0765 4017          STC 17 /SET UP FOR VALUE STORAGE VIA DECML
1055      0766 6244 P2,    JMP TRANSB /OVERLAY BE DORA PRT ROUT
1056      0767 0644          LDF 4 /GET NEXT PT VAL IN AC
1057      0770 6430          JMP DECML /CONVERT, STORE
1060      0771 0226          XSK I 6
1061      0772 0226          XSK I 6 /ADVANCE PTR 6 TO NEXT TTBI PTR
1062      0773 0227          XSK I 7
1063      0774 6762          JMP TYC1F /GET NEXT PARAMETER
1064                                     /NO MORE PARAMETERS
1065      /PRINT LINE
1066      0775 0644          LDF 4
1067      0776 2054          ADD P1 /PRNT LF,CR
1070      0777 6201          JMP PRLF
1071      1000 0061          SET I 1
1072      1001 7673          TYAN4+5777
1073      1002 6112          JMP PRNTLN
1074      1003 0230          XSK I 10
1075      1004 6743          JMP TYC1D /REINITIALIZE, GET NEXT POINT PARA
1076      1005 0604 V1,    LIF 4 /IF ALL PTS DONE, RETURN
1077      1006 6005          JMP 5
1100      EJECT

```

```

1101 /SUBROUTINE TO TRANSFER DATA
1102 /PTR 2 HAS START OF TAKE -1
1103 /PTR 3 HAS START OF PUT =1
1104 /PRT 4 HAS =NUM WDS OF TRANS
1105 1007 1000 TRDTA, LDA
1106 1010 0000 0
1107 1011 5017 STC TRDTAR
1110 1012 1022 TRDTA1, LDA I 2
1111 1013 1063 STA I 3
1112 1014 0011 CLR
1113 1015 0024 XSK I 4
1114 1016 7012 JMP TRDTA1
1115 1017 6000 TRDTAR, RETURN
1116 /B6 PART OF SUB TO PRINT MATCHING SPECTRA
1117 1020 0645 LBPRB, LDF 5
1120 1021 1020 LDA I
1121 1022 0003 3
1122 1023 6201 JMP PRLF /PRINT 3 LF
1123 1024 0061 SET I 1
1124 1025 6704 TY01+5777
1125 1026 6112 JMP PRNTLN /PRINT UNKNOWN
1126 1027 1040 STA
1127 1030 2745 TY02A+2000 /SET TO 0 TO CUT OFF NUM MISSES
1130 1031 0061 SET I 1
1131 1032 6722 TY04+5777 /PRINT SPEC, NUM PK PTS
1132 1033 6112 JMP PRNTLN
1133 1034 2052 ADD PLUS2
1134 1035 6201 JMP PRLF /PRINT 2 LF
1135 1036 0644 LDF 4
1136 1037 1040 STA
1137 1040 3623 TYAN1B+2000 /SET TO 0 TO CUT OFF NUM MISSES ANS
1140 /TRANSFER SPECTRUM NAME, NUM PTS OF UNKNOWN
1141 1041 0062 SET I 2
1142 1042 3531 TY07A+1777
1143 1043 0063 SET I 3
1144 1044 3606 TYAN1A+1777
1145 1045 0064 SET I 4
1146 1046 7767 7767
1147 1047 7007 JMP TRDTA /TRANSFER SPEC NAME
1150 1050 0640 LDF 0
1151 1051 1000 LDA
1152 1052 2035 PTSUNK+2000
1153 1053 0644 LDF 4
1154 1054 0077 SET I 17
1155 1055 7620 TYAN1F+5777
1156 1056 6430 JMP DECML /GET PTS
1157 1057 2055 ADD SPSP
1160 1060 1040 STA
1161 1061 3621 TYAN1F+2000 /IN 2 DIGITS
1162 /PRINT UNKNOWN LINE
1163 1062 0061 SET I 1
1164 1063 7603 TYANS+5777
1165 1064 6112 JMP PRNTLN
1166 1065 2055 ADD SPSP
1167 1066 0645 LDF 5
1170 1067 1040 STA
1171 1070 2745 TY02A+2000
1172 1071 0644 LDF 4
1173 1072 1040 STA
1174 1073 3623 TYAN1B+2000 /RESTORE IT
1175 1074 1020 LDA I
1176 1075 0003 3
1177 1076 6201 JMP PRLF /PRINT 3 LF

```

```

1200      1077 0045      LDF 5
1201      1100 0061      SET I 1
1202      1101 0713      TY03+5777
1203      1102 6112      JMP PRNTLN      /PRINT LIB
1204      1103 2052      ADD PLUS2
1205      1104 6201      JMP PRLF      /PRINT 2 LF
1206      1105 0061      SET I 1
1207      1106 6722      TY04+5777
1210      1107 6112      JMP PRNTLN      /PRINT SPEC, NUM PK PTS, MISSES
1211      1110 2052      ADD PLUS2
1212      1111 6201      JMP PRLF      /PRINT 2 LF
1213      1112 0076      SET I 16
1214      1113 2401      2401
1215      1114 6620      LBPRX, JMP SET16+2
1216      1115 0077      SET I 17
1217      1116 3606      TYAN1+2000      /INIT FOR SPEC TRANS
1220      1117 6244      LBPRC, JMP TRANSB      /PTR 16 AT INIT LOC SPEC
1221      1120 0450      AZE      /IS THIS THE END
1222      1121 7124      JMP LBPRD
1223      1122 0604      LIF 4      /YES,EXIT
1224      1123 6370      JMP LBPRRT
1225      1124 6217      LBPRD, JMP TRNSMD      /NO, TRANSFER DATA
1226      1125 1016      LDA 16
1227      1126 0450      AZE      /IS SPECTRUM DELETED = TAPE NAME=0
1230      1127 7137      JMP LBPRE
1231      1130 6244      JMP TRANSB      /YES, GET PAST IT
1232      1131 6244      JMP TRANSB
1233      1132 6244      JMP TRANSB      /TO PARA PTS
1234      1133 6635      JMP ADV16      /TO LAST SPECTRUM PT
1235      1134 0075      SET I 15
1236      1135 7767      7767
1237      1136 7115      JMP LBPRC=2      /TRY AGAIN
1240      1137 6244      LBPRE, /SET UP REST OF LINE
1241      1140 6244      JMP TRANSB
1242      1141 6244      JMP TRANSB
1243      1142 0077      SET I 17
1244      1143 7620      TYAN1F+5777
1246      1144 0644      LDF 4
1247      1145 6430      JMP DECLM      /CONVERT NUM PK PTS INTO TEXT BUFF
1250      1146 2055      ADD SP SP
1251      1147 1040      STA
1252      1150 3621      TYAN1F+2000      /WITH 2 DIGITS ONLY
1253      1151 0647      LDF 7
1254      1152 1016      LDA 16
1255      1153 0600      LIF 0      /GO TO B0 PORTION WITH NUM PTS IN AC
1256      1154 7054      JMP LBPRF
1257      /FIND SPECTRA MATCH, YES, AC=0, STOP LAST SPEC NMLOC
1260      /NO, AC NOT=0 =BUT, INIT BLK NUM IN AC CALL
1261      1155 4665      FNDSPB, STC TYCSB1      /STORE INIT BLK NUM
1262      1156 2000      ADD 0
1263      1157 5171      STC FNDRT
1264      1160 1020      LDA I
1265      1161 6726      JMP RETTY
1266      1162 4727      STC TYC2      /SET UP FIND SPEC ROUTINE
1267      1163 3173      ADD P16
1270      /AVOID HEADER PRINTOUT
1271      1164 4707      STC TYC1X
1272      1165 6662      JMP TYCSB+1      /GET SPEC PT
1273      1166 7201      JMP FNDSPC
1274      1167 7172      JMP RSTRTY      /NO MATCH, RESTORE
1275      1170 2042      ADD LF
1276      1171 6000      FNDRT, RETURN      /RETURN, AC+

```

```

1277      1172  1020  RSTRTY, LDA I   /RESTORE FIND SPEC ROUT
1300      1173  0016  P16,   16
1301      1174  4727          STC TYC2
1302      1175  1020          LDA I
1303      1176  6531          JMP TYB
1304      1177  4707          STC TYC1X
1305      1200  6000          JMP 0
1306      1201  7172  FNDSPC, JMP RSTRTY   /MATCH, RESTORE
1307      1202  7171          JMP FNDRT   /0 IN AC
1310          /SUBROUTINE TO STORE DATA WD IN THE AC IN THE
1311          /NEXT LOCATION IN A DATA BLK
1312          /IF NEXT LOC LAST IN BLOCK, GET NEW DATA BLK STORE
1313          /SET BIT MAP ETC,
1314      1203  0647  STRLFC, LDF 7
1315      1204  1056          STA 16   /STORE VALUE
1316      1205  1000          LDA
1317      1206  0000          0
1320      1207  5233          STC STRTRT
1321      1210  0236          XSK I 16   /IS THIS THE END OF A BLOCK
1322      1211  2016          ADD 16
1323      1212  1460          SAE I
1324      1213  2777          2777
1325      1214  7231          JMP STRTRT-2
1326      1215  0604          LIF 4   /YES
1327      1216  6447          JMP STRLFCB   /GET DAD SET, NEW BLK NUM IN AC
1330      1217  1056  STRLFC, STA 16   /STORE NEXT BLOCK
1331      1220  5223          STC STRTPA   /WRITE OUT OLD BLOCK
1332      1221  6174          JMP WTTAPE+1
1333          /SET NEW BLOCK IN PARA, AND PTR 16
1334      1222  1020          LDA I
1335      1223  0000  STRTPA, 0   /GET BLK NUM IN PARA
1336      1224  0644          LDF 4
1337      1225  1040          STA
1340      1226  2075          PARA+2002
1341      1227  0076          SET I 16
1342      1230  2400          2400   /INITIALIZE PTR 16
1343      1231  0644          LDF 4
1344      1232  0011          CLR
1345      1233  6000  STRTRT, RETURN /GO BACK, AC CLEAR
1346          /DORETTE PRINT ROUTINE PTR FAKE
1347      1234  0640  P4,   LDF 0   /BUMP DATA PTR
1350      1235  1036          LDA I 16
1351      1236  6000          JMP 0
1352          /SUBROUTINE TO GET DISPLAY ANSWER - NEVER CALL FROM B6
1353          /STORE AC VALUE IN TEXT STRING
1354      1237  0645  GETANS, LDF 5
1355      1240  1040          STA
1356      1241  2021          TXTSTR+2000
1357      1242  1020          LDA I
1360      1243  0040          40
1361      1244  2040          ADD LIFX
1362      1245  5246          STC ,+1
1363      1246  0000          0   /GET BACK ORIGINAL LDF
1364      1247  0605          LIF 5
1365      1250  6020          JMP DSCALL   /DO DSP, GET ANS, COULD BE IN LDF BUFF
1366      1251  0644  GTANS1, LDF 4
1367      1252  0011          CLR   /RETURN TO MAINLINE VIA B6 CALL
1370      1253  6040          JMP LIFX
1371          /SUBROUTINE TO MULTIPLY MULTMP,
1372          /ADD CONTENTS OF AC, STORE BACK
1373      1254  0000  MULTMP, 0
1374      1255  0000  MULACV, 0
1375      1256  5255  MULT10, STC MULACV

```

1376	1257	3254	ADD MULTMP	
1377	1260	1120	ADA I	/CHECK FOR OVERFLOW
1400	1261	7177	-600	/=3840 IF X10
1401	1262	0471	APO I	
1402	1263	7360	JMP MULT8E	
1403	1264	0011	CLR	
1404	1265	3254	ADD MULTMP	
1405	1266	0243	ROL 3	
1406	1267	3254	ADD MULTMP	
1407	1270	3254	ADD MULTMP	
1410	1271	3255	ADD MULACV	/HIGH ORDER X10
1411	1272	5254	STC MULTMP	/+AC, SAVE
1412	1273	6000	JMP 0	
1413			/SUBROUTINE TO MULTIPLY MULTMP BY 8	
1414			/ADD CONTENTS OF AC, STORE BACK	
1415			/IF AC>7, JUMP ILLEGAL	
1416	1274	1040	MULT8, STA	
1417	1275	1255	MULACV	
1420	1276	1560	BCL I	
1421	1277	0007	7	
1422	1300	0450	AZE	
1423	1301	7360	JMP MULT8E	/8 OR 9, JUMP ILLEGAL
1424	1302	3254	ADD MULTMP	
1425	1303	0243	ROL 3	
1426	1304	3255	ADD MULACV	/ELSE MULT, ADD AC
1427	1305	5254	STC MULTMP	
1430	1306	6000	JMP 0	
1431			/SUBROUTINE TO PROCESS BUFFER WHOOSE LOC	
1432			/IN PTR6, =NUM CHAR+1MAX PN PTR 7	
1433			/AC*01F DEC,+3777 IF OCTAL	
1434	1307	0000	BMULT1, 0	
1435	1310	5307	BMULT, STC BMULT1	
1436	1311	2000	ADD 0	
1437	1312	5357	STC BMULTR	/SAVE RET
1440	1313	5254	STC MULTMP	/INITIALIZE BUFF
1441	1314	0046	SET 6	/COPY PTRS
1442	1315	2006	2006	
1443	1316	0047	SET 7	
1444	1317	2007	2007	
1445	1320	1326	BMULT2, LDH I 6	/GET NUM IN AC, IF NOT NUM, JMP ILLEGAL
1446	1321	1420	SHD I	
1447	1322	3400	3400	/IS IT END OF FIELD
1450	1323	7355	JMP BMULTS	
1451	1324	1420	SHD I	
1452	1325	7400	7400	
1453	1326	7355	JMP BMULTS	
1454	1327	0470	AZE I	
1455	1330	7355	JMP BMULTS	/YES, OUT
1456	1331	1120	ADA I	
1457	1332	7706	7706	
1460	1333	0471	APO I	
1461	1334	7360	JMP MULT8E	
1462	1335	1120	ADA I	
1463	1336	0011	11	
1464	1337	0470	AZE I	
1465	1340	0011	CLR	
1466	1341	0451	APO	
1467	1342	7360	JMP MULT8E	
1470	1343	1500	SRO	
1471	1344	1307	BMULT1	
1472	1345	7274	JMP MULT8	/EITHER X8, BIT SET
1473	1346	1500	SRO	
1474	1347	1507	BMULT1	

```

1475      1350  0456      SKP
1476      1351  7256      JMP MULT10      /OR X10, BIT CLEAR
1477      1352  0227      XSK I 7
1500      1353  7320      JMP BMULT2      /JUMP BACK
1501      1354  7360      JMP      MULT8E /ELSE TOO MANY CHAR, ERROR
1502      1355  1000      BMULTS, LDA
1503      1356  1254      MULTMP /RESTORE PROCESSED NUM TO AC
1504      1357  6000      BMULTR, RETURN
1505
1506      1360  1000      /ERROR, DETERMINE CALLING BANK - 0 OR 4
1507      1361  0040      MULT8E, LDA
1510      1362  1460      LIFX      /GET UPPER=CALLING-FIELD
1511      1363  0600      SAE I
1512      1364  7373      600
1513      1365  0640      JMP CHBANK
1514      1366  1020      LDF 0
1515      1367  4062      LDA I      /SET UP ERR CD
1516      1370  3043      4062
1517      1371  0600      STA 2003
1520      1372  7764      LIF 0 /B0
1521
1522      1373  0604      JMP ILLG
1523      1374  6764      /B4
1524
1525      CHBANK, LIF 4
1526
1527      JMP MNLNER      /JUMP MAINLINE ERROR
1528
1529      *1400
1530
1531      /DISPLAY (MINI MAGSPY )
1532      /COPYRIGHT 1970
1533      /DIGITAL EQUIPMENT CORPORATION, MAYNARD, MASS.
1534      /MOVING WINDOW DISPLAY SUBROUTINE
1535      /CURSOR READ OUT
1536      /CORE OR TAPE FILE
1537      PMODE
1538
1539
1540
1541
1542
1543
1544
1545
1546
1547
1548
1549
1550
1551
1552
1553
1554
1555
1556
1557
1558
1559
1560
1561
1562
1563
1564
1565
1566
1567
1568
1569
1570
1571
1572
1573
1574
1575
1576
1577
1578
1579
1580
1581
1582
1583
1584
1585
1586
1587
1588
1589
1590
1591
1592
1593
1594
1595
1596
1597
1598
1599
1600
1601
1602
1603
1604
1605
1606
1607
1608
1609
1610
1611
1612
1613
1614
1615
1616
1617
1618
1619
1620
1621
1622
1623
1624
1625
1626
1627
1628
1629
1630
1631
1632
1633
1634
1635
1636
1637
1638
1639
1640
1641
1642
1643
1644
1645
1646
1647
1648
1649
1650
1651
1652
1653
1654
1655
1656
1657
1658
1659
1660
1661
1662
1663
1664
1665
1666
1667
1668
1669
1670
1671
1672
1673
1674
1675
1676
1677
1678
1679
1680
1681
1682
1683
1684
1685
1686
1687
1688
1689
1690
1691
1692
1693
1694
1695
1696
1697
1698
1699
1700
1701
1702
1703
1704
1705
1706
1707
1708
1709
1710
1711
1712
1713
1714
1715
1716
1717
1718
1719
1720
1721
1722
1723
1724
1725
1726
1727
1728
1729
1730
1731
1732
1733
1734
1735
1736
1737
1738
1739
1740
1741
1742
1743
1744
1745
1746
1747
1748
1749
1750
1751
1752
1753
1754
1755
1756
1757
1758
1759
1760
1761
1762
1763
1764
1765
1766
1767
1768
1769
1770
1771
1772
1773
1774
1775
1776
1777
1778
1779
1780
1781
1782
1783
1784
1785
1786
1787
1788
1789
1790
1791
1792
1793
1794
1795
1796
1797
1798
1799
1800
1801
1802
1803
1804
1805
1806
1807
1808
1809
1810
1811
1812
1813
1814
1815
1816
1817
1818
1819
1820
1821
1822
1823
1824
1825
1826
1827
1828
1829
1830
1831
1832
1833
1834
1835
1836
1837
1838
1839
1840
1841
1842
1843
1844
1845
1846
1847
1848
1849
1850
1851
1852
1853
1854
1855
1856
1857
1858
1859
1860
1861
1862
1863
1864
1865
1866
1867
1868
1869
1870
1871
1872
1873
1874
1875
1876
1877
1878
1879
1880
1881
1882
1883
1884
1885
1886
1887
1888
1889
1890
1891
1892
1893
1894
1895
1896
1897
1898
1899
1900
1901
1902
1903
1904
1905
1906
1907
1908
1909
1910
1911
1912
1913
1914
1915
1916
1917
1918
1919
1920
1921
1922
1923
1924
1925
1926
1927
1928
1929
1930
1931
1932
1933
1934
1935
1936
1937
1938
1939
1940
1941
1942
1943
1944
1945
1946
1947
1948
1949
1950
1951
1952
1953
1954
1955
1956
1957
1958
1959
1960
1961
1962
1963
1964
1965
1966
1967
1968
1969
1970
1971
1972
1973
1974
1975
1976
1977
1978
1979
1980
1981
1982
1983
1984
1985
1986
1987
1988
1989
1990
1991
1992
1993
1994
1995
1996
1997
1998
1999
2000
2001
2002
2003
2004
2005
2006
2007
2008
2009
2010
2011
2012
2013
2014
2015
2016
2017
2018
2019
2020
2021
2022
2023
2024
2025
2026
2027
2028
2029
2030
2031
2032
2033
2034
2035
2036
2037
2038
2039
2040
2041
2042
2043
2044
2045
2046
2047
2048
2049
2050
2051
2052
2053
2054
2055
2056
2057
2058
2059
2060
2061
2062
2063
2064
2065
2066
2067
2068
2069
2070
2071
2072
2073
2074
2075
2076
2077
2078
2079
2080
2081
2082
2083
2084
2085
2086
2087
2088
2089
2090
2091
2092
2093
2094
2095
2096
2097
2098
2099
2100
2101
2102
2103
2104
2105
2106
2107
2108
2109
2110
2111
2112
2113
2114
2115
2116
2117
2118
2119
2120
2121
2122
2123
2124
2125
2126
2127
2128
2129
2130
2131
2132
2133
2134
2135
2136
2137
2138
2139
2140
2141
2142
2143
2144
2145
2146
2147
2148
2149
2150
2151
2152
2153
2154
2155
2156
2157
2158
2159
2160
2161
2162
2163
2164
2165
2166
2167
2168
2169
2170
2171
2172
2173
2174
2175
2176
2177
2178
2179
2180
2181
2182
2183
2184
2185
2186
2187
2188
2189
2190
2191
2192
2193
2194
2195
2196
2197
2198
2199
2200
2201
2202
2203
2204
2205
2206
2207
2208
2209
2210
2211
2212
2213
2214
2215
2216
2217
2218
2219
2220
2221
2222
2223
2224
2225
2226
2227
2228
2229
2230
2231
2232
2233
2234
2235
2236
2237
2238
2239
2240
2241
2242
2243
2244
2245
2246
2247
2248
2249
2250
2251
2252
2253
2254
2255
2256
2257
2258
2259
2260
2261
2262
2263
2264
2265
2266
2267
2268
2269
2270
2271
2272
2273
2274
2275
2276
2277
2278
2279
2280
2281
2282
2283
2284
2285
2286
2287
2288
2289
2290
2291
2292
2293
2294
2295
2296
2297
2298
2299
2300
2301
2302
2303
2304
2305
2306
2307
2308
2309
2310
2311
2312
2313
2314
2315
2316
2317
2318
2319
2320
2321
2322
2323
2324
2325
2326
2327
2328
2329
2330
2331
2332
2333
2334
2335
2336
2337
2338
2339
2340
2341
2342
2343
2344
2345
2346
2347
2348
2349
2350
2351
2352
2353
2354
2355
2356
2357
2358
2359
2360
2361
2362
2363
2364
2365
2366
2367
2368
2369
2370
2371
2372
2373
2374
2375
2376
2377
2378
2379
2380
2381
2382
2383
2384
2385
2386
2387
2388
2389
2390
2391
2392
2393
2394
2395
2396
2397
2398
2399
2400
2401
2402
2403
2404
2405
2406
2407
2408
2409
2410
2411
2412
2413
2414
2415
2416
2417
2418
2419
2420
2421
2422
2423
2424
2425
2426
2427
2428
2429
2430
2431
2432
2433
2434
2435
2436
2437
2438
2439
2440
2441
2442
2443
2444
2445
2446
2447
2448
2449
2450
2451
2452
2453
2454
2455
2456
2457
2458
2459
2460
2461
2462
2463
2464
2465
2466
2467
2468
2469
2470
2471
2472
2473
2474
2475
2476
2477
2478
2479
2480
2481
2482
2483
2484
2485
2486
2487
2488
2489
2490
2491
2492
2493
2494
2495
2496
2497
2498
2499
2500
2501
2502
2503
2504
2505
2506
2507
2508
2509
2510
2511
2512
2513
2514
2515
2516
2517
2518
2519
2520
2521
2522
2523
2524
2525
2526
2527
2528
2529
2530
2531
2532
2533
2534
2535
2536
2537
2538
2539
2540
2541
2542
2543
2544
2545
2546
2547
2548
2549
2550
2551
2552
2553
2554
2555
2556
2557
2558
2559
2560
2561
2562
2563
2564
2565
2566
2567
2568
2569
2570
2571
2572
2573
2574
2575
2576
2577
2578
2579
2580
2581
2582
2583
2584
2585
2586
2587
2588
2589
2590
2591
2592
2593
2594
2595
2596
2597
2598
2599
2600
2601
2602
2603
2604
2605
2606
2607
2608
2609
2610
2611
2612
2613
2614
2615
2616
2617
2618
2619
2620
2621
2622
2623
2624
2625
2626
2627
2628
2629
2630
2631
2632
2633
2634
2635
2636
2637
2638
2639
2640
2641
2642
2643
2644
2645
2646
2647
2648
2649
2650
2651
2652
2653
2654
2655
2656
2657
2658
2659
2660
2661
2662
2663
2664
2665
2666
2667
2668
2669
2670
2671
2672
2673
2674
2675
2676
2677
2678
2679
2680
2681
2682
2683
2684
2685
2686
2687
2688
2689
2690
2691
2692
2693
2694
2695
2696
2697
2698
2699
2700
2701
2702
2703
2704
2705
2706
2707
2708
2709
2710
2711
2712
2713
2714
2715
2716
2717
2718
2719
2720
2721
2722
2723
2724
2725
2726
2727
2728
2729
2730
2731
2732
2733
2734
2735
2736
2737
2738
2739
2740
2741
2742
2743
2744
2745
2746
2747
2748
2749
2750
2751
2752
2753
2754
2755
2756
2757
2758
2759
2760
2761
2762
2763
2764
2765
2766
2767
2768
2769
2770
2771
2772
2773
2774
2775
2776
2777
2778
2779
2780
2781
2782
2783
2784
2785
2786
2787
2788
2789
2790
2791
2792
2793
2794
2795
2796
2797
2798
2799
2800
2801
2802
2803
2804
2805
2806
2807
2808
2809
2810
2811
2812
2813
2814
2815
2816
2817
2818
2819
2820
2821
2822
2823
2824
2825
2826
2827
2828
2829
2830
2831
2832
2833
2834
2835
2836
2837
2838
2839
2840
2841
2842
2843
2844
2845
2846
2847
2848
2849
2850
2851
2852
2853
2854
2855
2856
2857
2858
2859
2860
2861
2862
2863
2864
2865
2866
2867
2868
2869
2870
2871
2872
2873
2874
2875
2876
2877
2878
2879
2880
2881
2882
2883
2884
2885
2886
2887
2888
2889
2890
2891
2892
2893
2894
2895
2896
2897
2898
2899
2900
2901
2902
2903
2904
2905
2906
2907
2908
2909
2910
2911
2912
2913
2914
2915
2916
2917
2918
2919
2920
2921
2922
2923
2924
2925
2926
2927
2928
2929
2930
2931
2932
2933
2934
2935
2936
2937
2938
2939
2940
2941
2942
2943
2944
2945
2946
2947
2948
2949
2950
2951
2952
2953
2954
2955
2956
2957
2958
2959
2960
2961
2962
2963
2964
2965
2966
2967
2968
2969
2970
2971
2972
2973
2974
2975
2976
2977
2978
2979
2980
2981
2982
2983
2984
2985
2986
2987
2988
2989
2990
2991
2992
2993
2994
2995
2996
2997
2998
2999
3000
3001
3002
3003
3004
3005
3006
3007
3008
3009
3010
3011
3012
3013
3014
3015
3016
3017
3018
3019
3020
3021
3022
3023
3024
3025
3026
3027
3028
3029
3030
3031
3032
3033
3034
3035
3036
3037
3038
3039
3040
3041
3042
3043
3044
3045
3046
3047
3048
3049
3050
3051
3052
3053
3054
3055
3056
3057
3058
3059
3060
3061
3062
3063
3064
3065
3066
3067
3068
3069
3070
3071
3072
3073
3074
3075
3076
3077
3078
3079
3080
3081
3082
3083
3084
3085
3086
3087
3088
3089
3090
3091
3092
3093
3094
3095
3096
3097
3098
3099
3100
3101
3102
3103
3104
3105
3106
3107
3108
3109
3110
3111
3112
3113
3114
3115
3116
3117
3118
3119
3120
3121
3122
3123
3124
3125
3126
3127
3128
3129
3130
3131
3132
3133
3134
3135
3136
3137
3138
3139
3140
3141
3142
3143
3144
3145
3146
3147
3148
3149
3150
3151
3152
3153
3154
3155
3156
3157
3158
3159
3160
3161
3162
3163
3164
3165
3166
3167
3168
3169
3170
3171
3172
3173
3174
3175
3176
3177
3178
3179
3180
3181
3182
3183
3184
3185
3186
3187
3188
3189
3190
3191
3192
3193
3194
3195
3196
3197
3198
3199
3200
3201
3202
3203
3204
3205
3206
3207
3208
3209
3210
3211
3212
3213
3214
3215
3216
3217
3218
3219
3220
3221
3222
3223
3224
3225
3226
3227
3228
3229
3230
3231
3232
3233
3234
3235
3236
3237
3238
3239
3240
3241
3242
3243
3244
3245
3246
3247
3248
3249
3250
3251
3252
3253
3254
3255
3256
3257
3258
3259
3260
3261
3262
3263
3264
3265
3266
3267
3268
3269
3270
3271
3272
3273
3274
3275
3276
3277
3278
3279
3280
3281
3282
3283
3284
3285
3286
3287
3288
3289
3290
3291
3292
3293
3294
3295
3296
3297
3298
3299
3300
3301
3302
3303
3304
3305
3306
3307
3308
3309
3310
3311
3312
3313
3314
3315
3316
3317
3318
3319
3320
3321
3322
3323
3324
3325
3326
3327
3328
3329
3330
3331
3332
3333
3334
3335
3336
3337
3338
3339
3340
3341
3342
3343
3344
3345
3346
3347
3348
3349
3350
3351
3352
3353
3354
3355
3356
3357
3358
3359
3360
3361
3362
3363
3364
3365
3366
3367
3368
3369
3370
3371
3372
3373
3374
3375
3376
3377
3378
3379
3380
3381
3382
3383
3384
3385
3386
3387
3388
3389
3390
3391
3392
3393
3394
3395
3396
3397
3398
3399
3400
3401
3402
3403
3404
3405
3406
3407
3408
3409
3410
3411
3412
3413
3414
3415
3416
3417
3418
3419
3420
3421
3422
3423
3424
3425
3426
3427
3428
3429
3430
3431
3432
3433
3434
3435
3436
3437
3438
3439
3440
3441
3442
3443
3444
3445
3446
3447
3448
3449
3450
3451
3452
3453
3454
3455
3456
3457
3458
3459
3460
3461
3462
3463
3464
3465
3466
3467
3468
3469
3470
3471
3472
3473
3474
3475
3476
3477
3478
3479
3480
3481
3482
3483
3484
3485
3486
3487
3488
3489
3490
3491
3492
3493
3494
3495
3496
3497
3498
3499
3500
3501
3502
3503
3504
3505
3506
3507
3508
3509
3510
3511
3512
3513
3514
3515
3516
3517
3518
3519
3520
3521
3522
3523
3524
3525
3526
3527
3528
3529
3530
3531
3532
3533
3534
3535
3536
3537
3538
3539
3540
3541
3542
3543
3544
3545
3546
3547
3548
3549
3550
3551
3552
3553
3554
3555
3556
3557
3558
3559
3560
3561
3562
3563
3564
3565
3566
3567
3568
3569
3570
3571
3572
3573
3574
3575
3576
3577
3578
3579
3580
3581
3582
3583
3584
3585
3586
3587
3588
3589
3590
3591
3592
3593
3594
3595
3596
3597
3598
3599
3600
3601
3602
3603
3604
3605
3606
3607
3608
3609
3610
3611
3612
3613
3614
3615
3616
3617
3618
3619
3620
3621
3622
3623
3624
3625
3626
3627
3628
3629
3630
3631
3632
3633
3634
3635
3636
3637
3638
3639
3640
3641
3642
3643
3644
3645
3646
3647
3648
3649
3650
3651
3652
3653
3654
3655
3656
3657
3658
3659
3660
3661
3662
3663
3664
3665
3666
3667
3668
3669
3670
3671
3672
3673
3674
3675
3676
3677
3678
3679
3680
3681
3682
3683
3684
3685
3686
3687
3688
3689
3690
3691
3692
3693
3694
3695
3696
3697
3698
3699
3700
3701
3702
3703
3704
3705
3706
3707
3708
3709
3710
3711
3712
3713
3714
3715
3716
3717
3718
3719
3720
3721
3722
3723
3724
3725
3726
3727
3728
3729
3730
3731
3732
3733
3734
3735
3736
3737
3738
3739
3740
3741
3742
3743
3744
3745
3746
3747
3748
3749
3750
3751
3752
3753
3754
3755
3756
3757
3758
3759
3760
3761
3762
3763
3764
3765
3766
3767
3768
3769
3770
3771
3772
3773
3774
3775
3776
3777
3778
3779
3780
3781
3782
3783
3784
3785
3786
3787
3788
3789
3790
3791
3792
3793
3794
3795
3796
3797
3798
3799
3800
3801
3802
3803
3804
3805
3806
3807
3808
3809
3810
3811
3812
3813
3814
3815
3816
3817
3818
3819
3820
3821
3822
3823
3824
3825
3826
3827
3828
3829
3830
3831
3832
3833
3834
3835
3836
3837
3838
3839
3840
3841
3842
3843
3844
3845
3846
3847
3848
3849
3850
3851
3852
3853
3854
3855
3856
3857
3858
3859
3860
3861
3862
3863
3864
3865
3866
3867
3868
3869
3870
```

1574	5432	1636	TAD I	KMADR	/STARTING ADDR
1575	5433	3642	DCA I	KBUFLO	
1576	5434	5600	JMP I	IDORA	/RTN TO SCR N
1577	5435	5615	KMNFLD,	MINFLD	
1600	5436	5616	KMADR,	MINADR	
1601	5437	5674	KMXFLD,	MAXFLD	
1602	5440	5675	KMXADR,	MAXADR	
1603	5441	5774	KBUFHI,	BUFHI	
1604	5442	5775	KBUFLO,	BUFLO	
1605	5443	5644	KYSCAL,	YSCAL	
1606	5444	0401	P401,	401	
1607	5445	1244	DSCLOC,	TAD P401	/DSC X,Y COORD
1610	5446	3275	DCA	VCOORD	
1611	5447	1021	TAD	XCURHI	/FIELD
1612	5450	4262	JMS	DSCWD	
1613	5451	1022	TAD	XCURLO	/ADDRESS
1614	5452	4262	JMS	DSCWD	
1615	5453	1023	TAD	CORVAL	/CONTENTS OF
1616	5454	4262	JMS	DSCWD	/CURSR CORE LOC
1617	5455	1024	TAD	YCUR	/Y COORD OF
1620	5456	1244	TAD	P401	
1621	5457	4262	JMS	DSCWD	/CURSOR POINT
1622	5460	0000	RTNCFD,	0	/RESTORE USER
1623					/DATA FLD
1624	5461	5744	JMP I	RDORA	/RTN
1625	5462	0000	DSCWD,	0	/DSC C(AC)
1626	5463	6141	LINC		
1627			LMODE		
1630	1464	5477	STC	TEMP	/SAVE VALUE
1631	1465	4001	STC	XCORD	/CHAN 1
1632	1466	0024	SFA		/VC FOR FULL
1633	1467	0265	ROL I	5	/SIZE IS =40
1634	1470	1020	LDA I		/=20 FOR HALF
1635	1471	7757	-20		
1636	1472	0452	LZE		/FULL CHARS ?
1637	1473	0241	ROL 1		/NO VC-40
1640	1474	1160	ADM I		/UPDATE VC
1641	1475	0000	VCOORD,	0	
1642	1476	1020	DSCLOP,	LDA I	
1643	1477	0000	TEMP,	0	
1644	1500	0243	ROL 3		/1 DIGIT
1645	1501	1040	STA		/AT A TIME
1646	1502	1477	TEMP		/UPDATE
1647	1503	1560	BCL I		/LOW 3 BITS
1650	1504	7770	7770		/ONLY
1651	1505	0241	ROL 1		/*2 AND REL
1652	1506	1120	ADA I		/TO GRID TAB
1653	1507	1524	TAB&1777		
1654	1510	4002	STC 2		
1655	1511	3475	ADD	VCOORD	
1656	1512	1742	DSC 2		
1657	1513	1762	DSC I	2	
1660	1514	0221	XSK I	1	/MAKE GAP
1661	1515	0221	XSK I	1	/BETWEEN CHARS
1662	1516	1520	SRO I		/DSC 4 CHARS ?
1663	1517	3567	3567		
1664	1520	7476	JMP	DSCLOP	/NO CONT
1665	1521	0002	PDP		
1666			PMODE		
1667	5522	7300	CLA	CLL	
1670	5523	5662	JMP I	DSCWD	/RTN
1671	5524	4536	TAB,	4536	/60,0
1672	5525	3651	3651		

1673	5526	2101	2101	/61,1
1674	5527	0177	0177	
1675	5530	4523	4523	/62,2
1676	5531	2151	2151	
1677	5532	4122	4122	/63,3
1700	5533	2651	2651	
1701	5534	2414	2414	/64,4
1702	5535	0477	0477	
1703	5536	5172	5172	/65,5
1704	5537	0651	0651	
1705	5540	1506	1506	/66,6
1706	5541	4225	4225	
1707	5542	4443	4443	/67,7
1710	5543	6050	6050	
1711	5544	0000	RDORA, 0	
1712	5545	7300	CLA CLL	/SAVE USER DF
1713	5546	6214	RDF	
1714	5547	1017	TAD Z FLDZ0	
1715	5550	3260	DCA RTNCDF	
1716	5551	6141	LINC	
1717			LMODE	
1720	1552	0101	CSAM, CURSAM	/CURSOR
1721	1553	0341	SCR 1	/9 BITS COVERS
1722	1554	0002	PDP	/SCOPE
1723			PMODE	/MAKE RANGE
1724	5555	1244	TAD P401	/-1 TO =1000
1725	5556	7141	CIA CLL	
1726	5557	6141	LINC	
1727			LMODE	
1730	1560	5773	STC CURCNT&1777	
1731	1561	0100	WSAM, WINSAM	/WINDOW
1732	1562	0344	SCR 4	/75 CENTS WORTH
1733	1563	0061	SET I XCORD	
1734	1564	6777	XXCRD, -1000	/OVERLAYED IF <1000 PTS
1735	1565	7600	JMP CONT&1777	
1736			/WRITE TAPE UNIT 0	
1737			/THIS IS NOT ORETTTE	
1740			/THIS IS A LIFE INSERT	
1741	1566	0041	WTUN0, SET 1	
1742	1567	0000	0	
1743	1570	0002	PDP	
1744			PMODE	
1745	5571	6211	CDF 10	
1746	5572	4443	JMS I PWRITE	
1747	5573	0044	PARA0	
1750	5574	6141	LINC	
1751			LMODE	
1752	1575	0647	LDF 7	
1753	1576	0011	CLR	
1754	1577	6001	JMP 1	
1755			PMODE	
1756			PAGE	
1757	5600	0002	CONT, 2	
1760	5601	6211	CONF, CDF 10	
1761	5602	3347	DCA DBLLO	/PUT KNOB VAL
1762	5603	1347	TAD DBLLO	/IN DAC
1763	5604	7710	SPA CLA	/PROPAGATE SIGN
1764	5605	7040	CMA	/BIT HI ORD
1765	5606	3341	DCA DBLHI	
1766	5607	4304	JMS DA0D	
1767	5610	1347	TAD DBLLO	/UPDATE WIN ADDR
1770	5611	3375	DCA BUFLO	
1771	5612	1341	TAD DBLHI	

1772	5613	3374		DCA BUFHI	
1773					/MUST CHK
1774					/WINDOW SA
1775					/WITH BOUNDS
1776					/TO MAINTAIN
1777					/BUFFER RING
2000					
2001	5614	4316		JMS BOUND	/LOWER BOUND
2002	5615	0001		MINFLD, 1	
2003	5616	0000		MINADR, 0	
2004	5617	7700		SMA CLA	/LOW END WRAP?
2005	5620	5273		JMP CHKHI	/NO
2006	5621	1274		TAD MAXFLD	/RESET TO
2007	5622	3374		DCA BUFHI	/UPPER BOUND
2010	5623	1275		TAD MAXADR	
2011	5624	3375		WRAP, DCA BUFLO	
2012	5625	4304		JMS DADD	/CORRECT WRAP
2013	5626	1347		TAD DBLLO	/CORRECTED
2014	5627	3375		DCA BUFLO	/WINDOW SA
2015	5630	1341		TAD DBLHI	
2016	5631	3374		DCA BUFHI	
2017	5632	1375		SETFLD, TAD BUFLO	/SET DISPLAY
2020	5633	3304		DCA BUFPTR	/ARGS
2021	5634	1052		TAD NUMDIS	
2022	5635	3025		DCA COUNT	
2023	5636	1374		TAD BUFHI	
2024	5637	3316		DCA BOUND	
2025	5640	4341		JMS SETDF	
2026	5641	1704		NXTPNT, TAD I BUFPTR	
2027	5642	1020		TAD YSHFT	/OFF SET
2030	5643	6141		LINC	
2031				LMODE	
2032	1644	0341		YSCAL, SCR 1	/SCALE FACTOR
2033	1645	0161		DIS I XCORD	
2034	1646	0002		PDP	
2035				PMODE	
2036	5647	2373		ISZ CURCNT	/READY TO DIS
2037					/CURSOR ?
2040	5650	7610		CURRTN, SKP CLA	/NO
2041	5651	5351		JMP CURDIS	
2042	5652	2376		ISZ ENDLO	/CHK FOR HI
2043	5653	5263		JMP OKEND	/END WRAP
2044	5654	2377		ISZ ENDHI	
2045	5655	5263		JMP OKEND	
2046	5656	1216		TAD MINADR	/RESET TO
2047	5657	3304		DCA BUFPTR	/LOWER BOUND
2050	5660	1215		TAD MINFLD	
2051	5661	3316		DCA BOUND	
2052	5662	5266		JMP NXTDF	
2053	5663	2304		OKEND, ISZ BUFPTR	/CHK FOR FIELD
2054					/BOUNDARY
2055	5664	5267		JMP OKFLD	/ITS OK
2056	5665	2316		ISZ BOUND	/SET NXT FLD
2057	5666	4341		NXTDF, JMS SETDF	
2060	5667	2025		OKFLD, ISZ COUNT	/512 PNTS ?
2061	5670	5241		JMP NXTPNT	/NO
2062	5671	5672		JMP I ,+1	/DSC READ OUT
2063	5672	5445		DSCLOC	
2064	5673	4316		CHKHI, JMS BOUND	/CHK UPR BOUND
2065	5674	0002		MAXFLD, 2	
2066	5675	0000		MAXADR, 0	
2067	5676	7710		M70, SPA CLA	/HI WRAP ?
2070	5677	5232		JMP SETFLD	

2071	5700	1215	TAD MINFLD	/YES
2072	5701	3374	DCA BUFHI	/RESET TO
2073	5702	1216	TAD MINADR	/LOWER BOUND
2074	5703	5224	JMP WRAP	
2075			/DOUBLE PRECISION ADD	
2076			/(DBLHI,DBLLO)+(BUFHI,BUFLO)	
2077			/RESULT IN (DBLHI,DBLLO)	
2100			/(BUFHI,BUFLO)=INITIAL SCOPE ADDRESS	
2101				
2102	5704	0000	DADD, 0	
2103	5705	7300	CLA CLL	
2104	5706	1347	TAD DBLLO	
2105	5707	1375	TAD BUFLO	
2106	5710	3347	DCA DBLLO	
2107	5711	7004	RAL	
2110	5712	1341	TAD DBLHI	
2111	5713	1374	TAD BUFHI	
2112	5714	3341	DCA DBLHI	
2113	5715	5704	JMP I DADD	
2114				
2115			/ADD =UPPER OR =LOWER BOUND	
2116			/TO (BUFHI,BUFLO)	
2117			/BOUND IS AT P+1,P+2 OF CALL	
2120				
2121	5716	0000	BOUND, 0	
2122	5717	1716	TAD I BOUND	/2S COM OF ARG
2123	5720	7140	CMA CLL	/TO DAC
2124	5721	3341	DCA DBLHI	
2125	5722	2316	ISZ BOUND	
2126	5723	1716	TAD I BOUND	
2127	5724	7041	CIA	
2130	5725	7430	SZL	
2131	5726	2341	ISZ DBLHI	
2132	5727	7000	M1000, NOP	
2133	5730	3347	DCA DBLLO	
2134	5731	4304	JMS DADD	
2135	5732	1341	TAD DBLHI	
2136	5733	3377	DCA ENDHI	/DAC HOLDS -NUM
2137	5734	1347	TAD DBLLO	/TO END OF BUF
2140	5735	3376	DCA ENDLO	/NO MATTER FOR
2141				/LOW END WRAP
2142	5736	1341	TAD DBLHI	/TO CHK FOR
2143	5737	2316	ISZ BOUND	/UPON RTN
2144	5740	5716	JMP I BOUND	
2145	5741	0000	SETDF, 0	/SET 8 FIELD
2146	5742	1316	TAD BOUND	/REL TO BOUND
2147	5743	7106	CLL RTL	
2150	5744	7004	RAL	
2151	5745	1017	TAD Z FLDZ0	
2152	5746	3347	DCA ,+1	
2153	5747	0000	DBLLO, 0	
2154	5750	5741	JMP I SETDF	
2155	5751	3024	CURDIS, DCA YCUR	/DISP CURSOR
2156	5752	1316	TAD BOUND	/SAVE X,Y
2157	5753	3021	DCA XCURHI	/COORDINATES
2160	5754	1304	TAD BUFPTR	
2161	5755	3022	DCA XCURLO	
2162	5756	1704	TAD I BUFPTR	
2163	5757	3023	DCA CORVAL	
2164	5760	1276	TAD M70	
2165	5761	3347	DCA DBLLO	
2166	5762	1024	TAD YCUR	
2167	5763	6141	CURLOP, LINC	

```

2170
2171          1764 0465          LMODE
2172          1765 0016          SNS I 5
2173          /IF FREE CURSOR MOTION DESIRED
2174          1766 0141          NOP
2175          1767 0002          /CHANGE TO JMP FREE
2176          DIS XCORD
2177          PDP
2178          PMODE
2179          5770 2347          ISZ DBLLO
2200          5771 5363          JMP CURLOP
2201          5772 5250          JMP CURRTN
2202          5773 0000          CURCNT, 0
2203          /THESE 5 GUYS MAY BE PAGE 0
2204          5774 0001          BUFHI, 1
2205          5775 0000          BUFLO, 0
2206          5776 0000          ENDLO, 0
2207          5777 0000          ENDHI, 0
2210          DBLHI=SETDF
2211          BUFPTR=DADD
2212          XCORD=1
2213          LMODE
2214          CURSAM=SAM 1      /CURSOR KNOB
2215          WINSAM=SAM 0      /WINDOW KNOB
2216          FRESAM=SAM 5      /FREE CURSOR
2217          SCALE=SCR
2220          SC12BU=SCR 3      /SCALE FACTOR
2221          /12 BIT UNSIGNED
2222          OF12BU=4000        /Y OFFSET FOR
2223          /12 BIT UNSIGNED
2224          /THESE 6 GUYS MUST BE PAGE 0
2225          /THEY ARE ALL CONTIGUOUS AND DEFINED
2226          /RELATIVE TO YSHFT BUT THIS IS NOT
2227          /A REQUIREMENT
2230          YSHFT=20
2231          /THE 4 SCOPE READ OUT VALUES
2232          XCURHI=YSHFT+1
2233          XCURLO=XCURHI+1
2234          CORVAL=XCURLO+1
2235          YCUR=CORVAL+1
2236          COUNT=YCUR+1
2237          /AN EXAMPLE TO DISPLAY ALL OF FIELD 1
2240          /12 BIT UNSIGNED DATA
2241          /PMODE
2242          /*SOMEWHERE
2243          /JMS I KIDORA      /INITIAL CALL
2244          /1                /FLD
2245          /0000            /ADDR
2246          /1                /FLD
2247          /7777            /ADDR
2250          /OF12BU          /Y OFF SET
2251          /SC12BU          /Y SCALE FAC
2252          /JMS I KRORA      /REFRESH CALL
2253          /JMP .-1
2254          /KIDORA, IDORA
2255          /KRORA, RORA
2256          CHAIN "LIFE B5"

```

0000
0001
0002
0003
0004
0005
0006

*20

/THIS BANK WILL CONTAIN
/ALL TEXT STATEMENTS FOR QANDA
/IN ADDITION TO THE CALLING
/SEQUENCE FOR QANDA, AND QANDA ITSELF
/IN THE LAST TWO BLOCKS

SEGMENT 5

```

0007          *20
0010          /DISPLAY UNTIL ANSWER GIVEN
0011      0020  7000  DSCALL, JMP QAINIT
0012          /QANDA PTRS
0013      0021  0000  TXTSTR, 0
0014      0022  0000  ANSWER, 0
0015      0023  7053          JMP QARFSH
0016      0024  0606          LIF 6
0017      0025  7251          JMP GTANS1
0020      0026  0614
0020      0027  1106
0020      0030  0540
0020      0031  1123
0020      0032  4003
0020      0033  2205
0020      0034  0124
0020      0035  0504
0020          DSP1,  TEXT QFLIFE IS CREATED,
0021      0036  5643
0021
0022      0037  4740
0022      0040  4347
0022
0023      0041  4043
0023
0024      0042  4740
0024      0043  4347
0024      0044  1411
0024      0045  0605
0024      0046  4025
0024      0047  1611
0024      0050  2440
0024      0051  7462
0024      0052  3400
0024          LIFE UNIT <2\Q
0025      0053  1617
0025      0054  2440
0025      0055  1411
0025      0056  0605
0025      0057  4024
0025      0060  0120
0025          DSP2,  TEXT QNOT LIFE TAPE,
0026      0061  0556
0026      0062  4347
0026
0027      0063  4043
0027
0030      0064  4740
0030      0065  4347
0030      0066  1116
0030      0067  1124
0030      0070  1101
0030      0071  1411
0030      0072  3205
0030      0073  7740
0030      0074  3140
0030      0075  1722
0030      0076  4016
0030      0077  7240
0030      0100  7461
0030      0101  3400
0030          INITIALIZE? Y OR N: <1\Q
0031      0102  0606

```

0031	0103	2516
0031	0104	0324
0031	0105	1117
0031	0106	1623
0031		
0032	0107	7243
0032		
0033	0110	4740
0033	0111	4347
0033		
0034	0112	4043
0034	0113	4761
0034	0114	5640
0034	0115	0705
0034	0116	1605
0034	0117	2201
0034	0120	2405
0034	0121	4016
0034	0122	0527
0034	0123	4023
0034	0124	2005
0034	0125	0324
0034	0126	2225
0034		
0035	0127	1543
0035		
0036	0130	4740
0036	0131	4347
0036	0132	6256
0036	0133	4020
0036	0134	2211
0036		
0037	0135	1624
0037	0136	4347
0037		
0040	0137	4043
0040	0140	4763
0040	0141	5640
0040	0142	0522
0040	0143	0123
0040		
0041	0144	0543
0041		
0042	0145	4740
0042	0146	4347
0042	0147	6456
0042	0150	4003
0042	0151	0114
0042	0152	1440
0042	0153	0411
0042		
0043	0154	0114
0043	0155	4347
0043		
0044	0156	4043
0044		
0045	0157	4740
0045	0160	4340
0045	0161	0310
0045	0162	1711
0045	0163	0305
0045	0164	7240
0045	0165	7461

DSP3, TEXT OFFUNCTIONS:

1. GENERATE NEW SPECTRUM

2. PRINT

3. ERASE

4. CALL DIAL

0045	0166	3400	
0045			CHOICE: <1\Q
0046	0167	1116	
0046	0170	2324	
0046	0171	2225	
0046	0172	1505	
0046	0173	1624	
0046	0174	4016	
0046	0175	0115	
0046	0176	0540	
0046	0177	4074	
0046	0200	6434	
0046			DSP1P1, TEXT QINSTRUMENT NAME <4\Q
0047			/ABOVE ALSO USED IN DELETE
0050	0201	1605	
0050	0202	2740	
0050	0203	1116	
0050	0204	2324	
0050	0205	2225	
0050	0206	1505	
0050			DSP1P2, TEXT QNEW INSTRUMENT
0051	0207	1624	
0051	0210	4301	
0051	0211	0303	
0051	0212	0520	
0051	0213	2477	
0051	0214	4031	
0051	0215	4017	
0051	0216	2240	
0051	0217	1672	
0051	0220	4074	
0051			ACCEPT? Y OR N: <1
0052	0221	6143	
0052			
0053	0222	4740	
0053	0223	4347	
0053	0224	2431	
0053			TYPE
0054	0225	2005	
0054	0226	4347	
0054	0227	6140	
0054	0230	1106	
0054	0231	4030	
0054	0232	4017	
0054	0233	1614	
0054			1 IF X ONLY
0055	0234	3143	
0055	0235	4762	
0055	0236	4011	
0055	0237	0640	
0055	0240	3040	
0055	0241	0116	
0055	0242	0440	
0055			2 IF X AND Y
0056	0243	3143	
0056	0244	4774	
0056	0245	6134	
0056			<1\Q
0057	0246	2516	
0057	0247	1124	
0057	0250	4016	
0057	0251	0115	
0057	0252	0540	

0057	0253	4074	
0057			DSP1P3, TEXT QUNIT NAME <4
0060	0254	6443	
0060			
0061	0255	4740	
0061	0256	4347	
0061			
0062	0257	4043	
0062			
0063	0260	4740	
0063	0261	4347	
0063	0262	2320	
0063	0263	0503	
0063	0264	2422	
0063	0265	2515	
0063	0266	4016	
0063	0267	0115	
0063	0270	0540	
0063	0271	4074	
0063			SPECTRUM NAME <8
0064	0272	7043	
0064	0273	4774	
0064	0274	7034	
0064			<8\Q
0065	0275	2516	
0065	0276	1124	
0065	0277	4016	
0065	0300	2515	
0065	0301	0205	
0065	0302	2240	
0065	0303	4074	
0065			DSP1P4, TEXT QUNIT NUMBER <2
0066	0304	6243	
0066			
0067	0305	4740	
0067	0306	4347	
0067			
0070	0307	4043	
0070	0310	4723	
0070	0311	2401	
0070	0312	2224	
0070	0313	4002	
0070	0314	1417	
0070	0315	0313	
0070	0316	4040	
0070			START BLOCK <3
0071	0317	7463	
0071	0320	4347	
0071			
0072	0321	4043	
0072			
0073	0322	4740	
0073	0323	4347	
0073	0324	2024	
0073	0325	2340	
0073	0326	1116	
0073	0327	4023	
0073	0330	2005	
0073	0331	0324	
0073	0332	2225	
0073	0333	1540	
0073	0334	4074	
0073	0335	6434	

0073		
0074	0336	0114
0074	0337	1417
0074	0340	2701
0074	0341	0214
0074	0342	0540
0074	0343	0522
0074	0344	2217
0074	0345	2240
0074	0346	2417
0074	0347	1405
0074	0350	2201
0074	0351	1603
0074		
0075	0352	0572
0075	0353	4347
0075		
0076	0354	4043
0076	0355	4761
0076	0356	5540
0076	0357	2005
0076	0360	2240
0076	0361	0305
0076		
0077	0362	1624
0077	0363	4347
0077	0364	6255
0077	0365	4001
0077	0366	0223
0077	0367	1714
0077	0370	2524
0077		
0100	0371	0543
0100		
0101	0372	4740
0101	0373	4347
0101	0374	0310
0101	0375	1711
0101	0376	0305
0101	0377	7240
0101	0400	4074
0101		
0102	0401	6143
0102		
0103	0402	4740
0103	0403	4347
0103		
0104	0404	4043
0104	0405	4730
0104	0406	4024
0104	0407	1714
0104	0410	0522
0104	0411	0116
0104	0412	0305
0104	0413	7240
0104	0414	4074
0104		
0105	0415	6343
0105		
0106	0416	4740
0106	0417	4347
0106	0420	3140
0106	0421	2417

PTS IN SPECTRUM <4\0

DSP2P1, TEXT ALLOWABLE ERROR TOLERANCE:

1- PER CENT

2- ABSOLUTE

CHOICE: <1

X TOLERANCE: <3

0106	0422	1405
0106	0423	2201
0106	0424	1603
0106	0425	0572
0106	0426	4040
0106	0427	7463
0106	0430	3400
0107	0431	4015
0107	0432	1123
0107	0433	2305
0107	0434	2340
0107	0435	0114
0107	0436	1417
0107	0437	2705
0107	0440	0472
0107	0441	4040
0107	0442	7462
0107	0443	3400
0110	0444	0640
0110	0445	2022
0110	0446	1116
0111	0447	2472
0111	0450	4347
0112	0451	4043
0113	0452	4740
0113	0453	4347
0113	0454	6156
0113	0455	4011
0113	0456	1604
0114	0457	0530
0114	0460	4347
0115	0461	4043
0115	0462	4762
0115	0463	5640
0115	0464	1411
0115	0465	0222
0115	0466	0122
0115	0467	3140
0115	0470	2320
0115	0471	0503
0115	0472	2422
0116	0473	2515
0116	0474	4347
0117	0475	4043
0117	0476	4763
0117	0477	5640
0117	0500	0530
0120	0501	1124
0120	0502	4347
0121	0503	4043
0122	0504	4740

Y TOLERANCE: <3\Q

DSP2P2, TEXT Q MISSES ALLOWED: <2\Q

DSP3P1, TEXT QF PRINT:

1. INDEX

2. LIBRARY SPECTRUM

3. EXIT

0122	0505	4347
0122		
0123	0506	4043
0123	0507	4703
0123	0510	1017
0123	0511	1103
0123	0512	0572
0123	0513	7461
0123	0514	3400
0123		
0124	0515	0640
0124	0516	2431
0124		
0125	0517	2005
0125	0520	4347
0125		
0126	0521	4043
0126		
0127	0522	4740
0127	0523	4347
0127	0524	1116
0127	0525	2324
0127	0526	2225
0127	0527	1505
0127	0530	1624
0127	0531	4016
0127	0532	0115
0127	0533	0572
0127	0534	4040
0127	0535	4040
0127		
0130	0536	7464
0130	0537	4347
0130		
0131	0540	4043
0131		
0132	0541	4740
0132	0542	4347
0132	0543	2320
0132	0544	0503
0132	0545	2422
0132	0546	2515
0132	0547	4016
0132	0550	0115
0132	0551	0572
0132	0552	4040
0132	0553	4040
0132		
0133	0554	7470
0133	0555	4347
0133	0556	7470
0133	0557	3400
0133		
0134		
0135	0560	0605
0135	0561	2201
0135	0562	2305
0135		
0136	0563	7243
0136		
0137	0564	4740
0137	0565	4347
0137		

CHOICE:<1\Q

DSP3P2, TEXT QF TYPE

INSTRUMENT NAME: <4

SPECTRUM NAME: <8

<8\Q
/DSP 4.2 IS DSP 1.1

DSP4P1, TEXT QFERASE:

0140	0566	4043
0140	0567	4761
0140	0570	5640
0140	0571	0516
0140	0572	2411
0140	0573	2205
0140	0574	4014
0140	0575	1102
0140	0576	2201
0140		
0141	0577	2231
0141	0600	4347
0141	0601	6256
0141	0602	4005
0141	0603	1624
0141	0604	1122
0141	0605	0540
0141	0606	1116
0141	0607	2324
0141	0610	2225
0141	0611	1505
0141		
0142	0612	1624
0142	0613	4347
0142	0614	6356
0142	0615	4023
0142	0616	1116
0142	0617	0714
0142	0620	0540
0142	0621	2320
0142	0622	0503
0142	0623	2422
0142		
0143	0624	2515
0143	0625	4347
0143	0626	6456
0143	0627	4005
0143	0630	3011
0143		
0144	0631	2443
0144		
0145	0632	4740
0145	0633	4347
0145		
0146	0634	4043
0146	0635	4703
0146	0636	1017
0146	0637	1103
0146	0640	0574
0146	0641	6134
0146		
0147	0642	0640
0147	0643	2320
0147	0644	0503
0147	0645	2422
0147	0646	2515
0147	0647	4016
0147	0650	0115
0147	0651	0572
0147	0652	4040
0147	0653	4040
0147	0654	7464
0147	0655	3400

1. ENTIRE LIBRARY

2. ENTIRE INSTRUMENT

3. SINGLE SPECTRUM

4. EXIT

CHOICE<1\Q

0147			DSP4P3, TEXT QF SPECTRUM NAME:	<4\Q
0150	0656	4040	DSPERB, 4040	
0151	0657	0522		
0151	0660	2217		
0151			DSPERA, TEXT QERROR	
0152	0661	2240		
0152	0662	4347		
0152			Q	
0153	0663	3131	ERRCXX, 3131	/XX
0154	0664	4043	4043	
0155	0665	4043	4043	
0156	0666	2022		
0156	0667	0523		
0156	0670	2340		
0156	0671	1411		
0156	0672	1605		
0156	0673	4006		
0156	0674	0505		
0156	0675	0454		
0156	0676	4024		
0156	0677	2231		
0156	0700	4001		
0156	0701	0701		
0156	0702	1116		
0156	0703	7461		
0156	0704	3400		
0156			TEXT QPRESS LINE FEED, TRY AGAIN<1\Q	
0157	0705	4040	TY01, 4040	
0160	0706	4040	4040	
0161	0707	2516		
0161	0710	1316		
0161	0711	1727		
0161	0712	1672		
0161			TEXT QUNKNOWN:Q	
0162	0713	0000	0000	
0163	0714	4040	TY03, 4040	
0164	0715	4040	4040	
0165	0716	1411		
0165	0717	0222		
0165	0720	0122		
0165	0721	3172		
0165			TEXT QLIBRARY:Q	
0166	0722	0000	0000	
0167	0723	4040	TY04, 4040	
0170	0724	4040	4040	
0171	0725	4040	4040	
0172	0726	2320		
0172	0727	0503		
0172	0730	2422		
0172	0731	2515		
0172			TEXT QSPECTRUMQ	
0173	0732	4040	4040	
0174	0733	4040	4040	
0175	0734	4040	4040	
0176	0735	4040	4040	
0177	0736	4040	4040	
0200	0737	4040	4040	
0201	0740	2013		
0201	0741	5640		
0201	0742	2024		
0201	0743	2340		
0201			TEXT QPK, PTS Q	
0202	0744	4040	4040	

```

0203      0745  4040  TY02A,  4040  /SET TO 0 IF UNKNOWN LINE
0204      0746  1511
0204      0747  2323
0204      0750  0523
0204      TEXT QMISSESQ
0205      0751  0000      0000
0206      0752  4040  TY05,   4040
0207      0753  4040      4040
0210      0754  4040      4040
0211      0755  4040      4040
0212      0756  4040      4040
0213      0757  4040      4040
0214      0760  1116
0214      0761  0405
0214      0762  3040
0214      0763  1706
0214      0764  4014
0214      0765  1102
0214      0766  2201
0214      0767  2231
0214      0770  4023
0214      0771  2005
0214      0772  0324
0214      0773  2201
0214      TEXT QINDEX OF LIBRARY SPECTRAQ
0215      0774  0000      0000
0216      /QANDA SUBROUTINE FOR THE
0217      /PDP=12
0220      *1000
0221      /
0222      /TO HERE TO INITIALIZE THE ROUTINE
0223      /
0224      1000  1020  QAINIT, LDA I      /SAVE JMP RETURN
0225      1001  0002      2
0226      1002  2000      ADD 0
0227      1003  1060      STA I
0230      1004  0000  QAB,    0      /JMP +3
0231      1005  3200      ADD QAL+3
0232      1006  4001      STC 1      /PTR TO FIRST PARAM
0233      1007  1001      LDA 1      /GET FIRST PARAM
0234      1010  3264      ADD QAQ+1   /PTR TO HALFWORD-1
0235      1011  5057      STC QAQ-3
0236      1012  1021      LDA I 1
0237      1013  5052      STC QARFSH-1
0240      1014  4006      STC 6      /XR6 USED AS A SWITCH, =0 IF NO ANSWER FIELD, #1777 IF YES
0241      1015  0043  QACA,  SET 3   /XR3 TO PTR TO ANSWERS
0242      1016  1052      QARFSH=1
0243      1017  0044      SET 4      /XR4 TO PTR TO QUESTIONS
0244      1020  1057      QAG=3
0245      /TO HERE IF FIRST TIME THROUGH OR FOLLOWING A CR
0246      1021  0041      SET 1
0247      1022  0004      4
0250      1023  7270      JMP QAT
0251      1024  0016      NOP      /F
0252      1025  1324      LDH I 4   /H, BUMP PTR IF H OR F
0253      1026  7231  QAD,    JMP QAO
0254      1027  7035      JMP ,+6   /74
0255      1030  7050      JMP QAE   /34
0256      1031  1460      SAE I    /CR?
0257      1032  0043      43
0260      1033  7026      JMP QAD   /NO
0261      1034  7021      JMP QACA+4 /EXAMINE NEXT CHAR
0262      /INITIALIZE ANSWER BUFR
=

```

0263	1035	1343	STH 3	/74 TO ANSWERS
0264	1036	1324	LDH I 4	/NEXT HALFWORD
0265	1037	1120	ADA I	
0266	1040	7717	-60	
0267	1041	0017	COM	
0270	1042	4006	STC 6	
0271	1043	1363	STH I 3	/0 IN AC
0272	1044	0226	XSK I 6	
0273	1045	7043	JMP .=2	
0274	1046	1323	LDH I 3	/BUMP PTR TO ANSWERS
0275	1047	7026	JMP QAD	
0276				/ANSWER BUFR IS INITIATED
0277	1050	1343	QAE, STH 3	
0300	1051	0064	SET I 4	/XR4 TO PTR TO LAST TYPED CHAR IN ANSWER BUFR
0301	1052	0000	0	
0302				/---RE-ENTER HERE TO REFRESH---
0303	1053	1020	QARFSH, LDA I	/INITIAL Y POSITION
0304	1054	0277	277	
0305	1055	5113	STC QAH-1	
0306	1056	0063	SET I 3	/XR3 TO PTR TO HALFWORD QUESTIONS-1
0307	1057	0000	0	
0310	1060	0045	SET 5	/XR5 TO PTR TO LAST DISPLAYED CHAR IN ANSWER BUFR
0311	1061	1052	QARFSH=1	
0312	1062	0041	QAG, SET 1	
0313	1063	0003	3	
0314	1064	7270	JMP QAT	
0315	1065	7074	JMP .+7	/F
0316	1066	1323	LDH I 3	/H, BUMP PTR
0317	1067	1020	LDA I	/NEITHER, ASSUME HALF SIZE
0320	1070	1560	BCL I	
0321	1071	5103	STC QAM+2	/SET INSTR TO CLEAR FF FOR HALF SIZE
0322	1072	3512	ADD QAW	/NOP IN AC
0323	1073	7101	JMP QAM	
0324	1074	1323	LDH I 3	/BUMP PTR
0325	1075	1020	LDA I	
0326	1076	1620	BSE I	
0327	1077	5103	STC QAM+2	/SET INSTR TO SET FF FOR FULL SIZE
0330	1100	3513	ADD QAW+1	/ADD 9U IN AC
0331	1101	5245	QAM, STC QAP+3	
0332	1102	0024	MSC I 4	/EAD CONTROL REGISTER
0333	1103	1620	BSE I	/THIS INSTR CHANGES, EITHER BSE & OR BCL &
0334	1104	0200	200	
0335	1105	0004	MSC 4	/AC TO CONTROL REGISTER
0336	1106	0061	SET I 1	/XR1 TO INITIAL X POSITION
0337	1107	0100	100	
0340	1110	1020	LDA I	/Y COORDINATE MULTIPLE
0341	1111	7737	=40	
0342	1112	1160	ADM I	/Y COORDINATE
0343	1113	0000	0	
0344	1114	1323	QAH, LDH I 3	
0345	1115	7232	JMP QA0+1	
0346	1116	7301	JMP QAZ	/74 BUMP PTR TO NEXT CHAR, PUT 40 IN AC
0347	1117	7136	JMP QAJ	/34
0350	1120	1420	SHD I	/NEITHER
0351	1121	4300	4300	
0352	1122	7062	JMP QAG	/CR, MOVE X AND Y COORDINATE
0353	1123	7242	JMP QAP	/ISPLAY CHAR
0354	1124	7114	JMP QAH	/PICK UP NEXT CHAR
0355	1125	7242	JMP QAP	/TO HERE IF DISPLAYING ANSWER BUFR
0356	1126	1520	SRO I	/SWITCH TO DISPLAY CURSOR, EITHER 0000 OR 7777
0357	1127	0000	0	/IFXR4=XR5, THEN SWITCH=7777
0360	1130	7516	JMP QAF	
0361				/QUESTION MODE

0362	1131	1325	QAI,	LDH I 5	
0363	1132	7232		JMP QAO+1	
0364	1133	7114		JMP QAH	/74
0365	1134	7114		JMP QAH	/34
0366	1135	7125		JMP QAI-4	/NEITHER, DISPLAY IT
0367	1136	7521	QAJ,	JMP GETKBD	/TO HERE IF DISPLAYED BUFFER
0370	1137	0470		AZE I	
0371	1140	7004		JMP QAB	/NOTHING TYPED , EXIT
0372	1141	0062		SET I 2	
0373	1142	1412		QAY	
0374	1143	1402		SHD 2	/LF?
0375	1144	7311		JMP QAK+4	/YES. EXIT
0376	1145	1422		SHD I 2	/CR?
0377	1146	7223		JMP QAN	
0400	1147	0206		XSK 6	/IS THERE AN ANSWER FIELD?
0401	1150	7053		JMP QARFSH	
0402	1151	1422		SHD I 2	/<?
0403	1152	7175		JMP QAL	
0404	1153	1422		SHD I 2	/>?
0405	1154	7305		JMP QAK	
0406	1155	1422		SHD I 2	/ALT?
0407	1156	7015		JMP QACA	/REINITIALIZE
0410	1157	1422		SHD I 2	/BACK SLASH?
0411	1160	7053		JMP QARFSH	/IGNORE
0412	1161	1422		SHD I 2	/RUBOUT?
0413	1162	7175		JMP QAL	/IGNORE
0414	1163	1422		SHD I 2	/TAB?
0415	1164	7053		JMP QARFSH	/IGNORE
0416	1165	5172		STC ,+5	/ACCEPTABLE CHAR
0417	1166	7231		JMP QAO	/TEST NEXT CHAR
0420	1167	7263		JMP QAQ	/74 BACK PTR UP BY 1
0421	1170	7263		JMP QAO	/34 *
0422	1171	1020		LDA I	/OK, STORE IT
0423	1172	0000		0	
0424	1173	1344		STH 4	
0425	1174	7053		JMP QARFSH	/REDISPLAY
0426	1175	1304	QAL,	LDH 4	/TO HERE IF RUBBOUT OR <
0427	1176	7232		JMP QAO+1	
0430	1177	7053		JMP QARFSH	/74 IGNORE
0431	1200	1775		=6002	
0432	1201	1302		LDH 2	/TEST THE CHAR
0433	1202	1460		SAE I	/RUBOUT?
0434	1203	0037		37	
0435	1204	7263		JMP QAQ	/NO. BACK PTR UP BY 1
0436	1205	0045		SET 5	
0437	1206	0004		4	
0440	1207	0043		SET 3	
0441	1210	0004		4	
0442	1211	7213		JMP ,+2	
0443	1212	1325		LDH I 5	/BUMP PTR
0444	1213	1323		LDH I 3	/GET NEXT CHAR
0445	1214	7232		JMP QAO+1	
0446	1215	0016		NOP	/IF 74 OR 34, REPLACE CURRENT CHAR WITH 0
0447	1216	0011		CLR	
0450	1217	1345		STH 5	
0451	1220	0450		AZE	/WAS IT 74 OR 34?
0452	1221	7212		JMP ,=7	/NO, CONTINUE
0453	1222	7263		JMP QAQ	/BACK PTR UP BY 1
0454					/TO HERE IF CR
0455	1223	0206	QAN,	XSK 6	
0456	1224	7311		JMP QAK+4	/EXIT ROUTINE IF NO ANSWER FIELD
0457	1225	7231		JMP QAO	
0460	1226	7053		JMP QARFSH	/74 MOVE PTR TO NEXT QUESTION FIELD

0461	1227	7051		JMP QAE+1	/34 END OF BUFR, MOVE PTR TO FIRST QUESTION FIELD
0462	1230	7225		JMP QAN+2	
0463					
0464	1231	1324	QAQ,	LDH I 4	/S\R
0465	1232	1420		SHD I	/
0466	1233	7400		7400	+1 74 BEGIN FIELD
0467	1234	6000		JMP 0	+2 34 END BUFR
0470	1235	1460		SAE I	+3 NEITHER 74 NOR 34
0471	1236	0034		34	
0472	1237	0220		XSK I 0	
0473	1240	0220		XSK I 0	
0474	1241	6000		JMP 0	
0475					
0476	1242	0241	QAP,	ROL 1	/S\R TO DISP LINC CHAR IN AC
0477	1243	3430		ADD QAX+4	/MULT BY 2 FOR INDEX TO ADDRESS OF TABLE
0500	1244	4002		STC 2	/ADDRESS OF CHAR TO DISP IN XR2
0501	1245	3506		ADD QAU	/THIS INSTR CHANGES, EITHER OP OR ADD 9U
0502	1246	3506		ADD QAU	
0503	1247	2001		ADD 1	/ADD 4 TO XR1 TO SPACE CHAR
0504	1250	4001		STC 1	
0505	1251	2005		ADD 5	/GET ADDRESS OF ANSWER BUFR
0506	1252	0017		COM	
0507	1253	2004		ADD 4	
0510	1254	0450		AZE	
0511	1255	0011		CLR	
0512	1256	5127		STC QA I=2	/SWITCH=0 OR 7777
0513	1257	3113		ADD QAH=1	/Y COORDINATE IN AC
0514	1260	1742		DSC 2	
0515	1261	1762		DSC I 2	/DISPLAY CHAR
0516	1262	6000		JMP 0	
0517	1263	1020	QAQ,	LDA I	/BACK UP PTR BY 1
0520	1264	3777		=4000	
0521	1265	1140		ADM	
0522	1266	0004		4	
0523	1267	7053		JMP QARFSH	/REDISPLAY
0524					/
0525	1270	1321	QAT,	LDH I 1	/S\R
0526	1271	1420		SHD I	/
0527	1272	0600		0600	+1 F
0530	1273	6000		JMP 0	+2 H
0531	1274	1460		SAE I	+3 NEITHER
0532	1275	0010		10	
0533	1276	0220		XSK I 0	
0534	1277	0220		XSK I 0	
0535	1300	6000		JMP 0	
0536					/
0537	1301	1323	QAZ,	LDH I 3	
0540	1302	1020		LDA I	
0541	1303	0040		40	
0542	1304	7125		JMP QA I=4	
0543					/TO HERE IF >
0544	1305	1324	QAK,	LDH I 4	
0545	1306	0470		AZE I	/IS CURRENT CHAR BLANK?
0546	1307	7263		JMP QAQ	/YES. IGNORE
0547	1310	7424		JMP QAX	/MOVE DOT FORWARD
0550					/TO HERE TO EXIT WITH SKIP
0551	1311	1020		LDA I	
0552	1312	0001		1	
0553	1313	1140		ADM	
0554	1314	1004		QAB	
0555	1315	7004		JMP QAB	
0556					/CHARACTER PATTERNS
0557	1316	0101	QAV,	0101	/KBD 0, ILLEGAL, USED AS MARKER

0560	1317	0101	0101	
0561	1320	4477	4477	/1:A
0562	1321	7744	7744	
0563	1322	5177	5177	/2:B
0564	1323	2651	2651	
0565	1324	4136	4136	/3:C
0566	1325	2241	2241	
0567	1326	4177	4177	/4:D
0570	1327	3641	3641	
0571	1330	4577	4577	/5:E
0572	1331	4145	4145	
0573	1332	4477	4477	/6:F
0574	1333	4044	4044	
0575	1334	4136	4136	/7:G
0576	1335	2645	2645	
0577	1336	1077	1077	/10:H
0600	1337	7710	7710	
0601	1340	7741	7741	/11:I
0602	1341	0041	0041	
0603	1342	4142	4142	/12:J
0604	1343	4076	4076	
0605	1344	1077	1077	/13:K
0606	1345	4324	4324	
0607	1346	0177	0177	/14:L
0610	1347	0301	0301	
0611	1350	3077	3077	/15:M
0612	1351	7730	7730	
0613	1352	3077	3077	/16:N
0614	1353	7706	7706	
0615	1354	4177	4177	/17:O
0616	1355	7741	7741	
0617	1356	4477	4477	/20:P
0620	1357	3044	3044	
0621	1360	4276	4276	/21:Q
0622	1361	0376	0376	
0623	1362	4477	4477	/22:R
0624	1363	3146	3146	
0625	1364	5121	5121	/23:S
0626	1365	4651	4651	
0627	1366	4040	4040	/24:T
0630	1367	4077	4077	
0631	1370	0177	0177	/25:U
0632	1371	7701	7701	
0633	1372	0176	0176	/26:V
0634	1373	7402	7402	
0635	1374	0677	0677	/27:W
0636	1375	7701	7701	
0637	1376	1463	1463	/30:X
0640	1377	6314	6314	
0641	1400	0770	0770	/31:Y
0642	1401	7007	7007	
0643	1402	4543	4543	/32:Z
0644	1403	6151	6151	
0645	1404	4177	4177	/33:/
0646	1405	0000	0000	
0647				/34:BACKSLASH IGNORED ON INPUT
0650	1406	0000	0	/NOT USED
0651	1407	0000	0	/NOT USED
0652	1410	0000	0000	/35:]
0653	1411	7741	7741	
0654				/CODES 36:ALT, 37:RUBOUT NOT DISPLAYED
0655	1412	4543	4543	/LF,CR
0656	1413	7476	7476	/<,>

0657	1414	3634	3634	/ALT, BACKSLASH
0660	1415	3747	3747	/RUB OUT, TAB
0661	1416	0000	0000	/40:SPACE
0662	1417	0000	0000	
0663	1420	7500	7500	/41:X!
0664	1421	0000	0000	
0665	1422	7000	7000	/42:"
0666	1423	0070	0070	
0667				/CODES 43:, 44:, 45:LF NOT DISPLAYED
0670	1424	7232	QAX, JMP QA0+1	
0671	1425	7263	JMP QAQ	
0672	1426	7263	JMP QAQ	
0673	1427	7053	JMP QARFSH	
0674	1430	1316	QAV	
0675	1431	0000	0	/NOT USED
0676	1432	5166	5166	/46: &
0677	1433	0526	0526	
0700				/CODE 47:TAB NOT DISPLAYED
0701	1434	0000	0	/NOT USED
0702	1435	0000	0	/NOT USED
0703	1436	3600	3600	/50:(
0704	1437	0041	0041	
0705	1440	4100	4100	/51:)
0706	1441	0036	0036	
0707	1442	2050	2050	/52:*
0710	1443	0050	0050	
0711	1444	0404	0404	/53:+
0712	1445	0437	0437	
0713	1446	0500	0500	/54:,
0714	1447	0006	0006	
0715	1450	0404	0404	/55:-
0716	1451	0404	0404	
0717	1452	0001	0001	/56:.
0720	1453	0000	0000	
0721	1454	0601	0601	/57:\
0722	1455	4030	4030	
0723	1456	4536	4536	/60:0
0724	1457	3651	3651	
0725	1460	2101	2101	/61:1
0726	1461	0177	0177	
0727	1462	4523	4523	/62:2
0730	1463	2151	2151	
0731	1464	4122	4122	/63:3
0732	1465	2651	2651	
0733	1466	2414	2414	/64:4
0734	1467	0477	0477	
0735	1470	5172	5172	/65:5
0736	1471	0651	0651	
0737	1472	1506	1506	/66:6
0740	1473	4225	4225	
0741	1474	4443	4443	/67:7
0742	1475	6050	6050	
0743	1476	5126	5126	/70:8
0744	1477	2651	2651	
0745	1500	5122	5122	/71:9
0746	1501	3651	3651	
0747	1502	2200	2200	/72::
0750	1503	0000	0000	
0751	1504	4601	4601	/73:;
0752	1505	0000	0000	
0753				/CODE 74:<NOT DISPLAYED
0754	1506	0002	QAU, 2	/CONSTANT
0755	1507	0000	0	/NOT USED

```

0756      1510 1212      1212      /75:=
0757      1511 1212      1212
0760
0761      1512 0016  QAW,  NOP
0762      1513 3506      ADD QAU
0763      1514 4020      4020      /77! ?
0764      1515 2055      2055
0765
0766      1516 1760  QAF,  DSC I
0767      1517 6000      6000
0770      1520 7131      JMP QAI
0771
0772
0773
0774
0775
0776
0777      /KEYBOARD INPUT ROUTINE
1000
1001      QAKRB=6036      /PDP-8 IOT KBD
1002      QATSF=6041      /TSF
1003      QATLS=6046      /TLS
1004
1005      1521 1000  GETKBD, LDA
1006      1522 0000      0
1007      1523 5647      STC QAEXIT+6      /SAVE RETURN
1010      1524 2001      ADD 1      /SAVE XRS 1 AND 2
1011      1525 5644      STC QAEXIT+3
1012      1526 2002      ADD 2
1013      1527 5646      STC QAEXIT+5
1014      1530 5642      STC QAEXIT+1
1015      1531 0415      KST      /WAS SOMETHING TYPED?
1016      1532 6000      JMP 0      /NO! EXIT
1017      1533 0500      IOB
1020      1534 6036      QAKRB      /GET TTY CHAR, CLEAR FLAG
1021      1535 1060      STA I      /SAVE IT
1022      1536 0000  QATY,  0
1023      1537 1120      ADA I
1024      1540 7540      -237
1025      1541 0451      APO      /BETWEEN 200 AND 237?
1026      1542 7604      JMP QACNTR      /CONTROL CHAR. CHECK FOR CR,LF,TAB
1027
1030      1543 0061      SET I 1      /NO
1031      1544 1660      QACHAR-1
1032      1545 0062      SET I 2
1033      1546 7770      -7
1034      1547 1000      LDA
1035      1550 1536      QATY
1036      1551 1461      SAE I 1
1037      1552 7554      JMP .+2
1040      1553 7641      JMP QAEXIT      /ILLEGAL CHAR. DONT ECHO
1041      1554 0222      XSK I 2 /CHECKED THEM ALL?
1042      1555 7551      JMP .+4
1043
1044      1556 1120      ADA I
1045      1557 7440      -337
1046      1560 0451      APO      /BETWEEN 240 AND 337?
1047      1561 7575      JMP QALEGL      /YES, LEGAL CHAR
1050
1051      1562 1461      SAE I 1      /NO, CHECK FURTHER,
1052      1563 7572      JMP .+7
1053      1564 1020      LDA I      /RUBOUT
1054      1565 0334      334

```

```

1055      1566 7650      JMP QATPE      /ECHO BACKSLASH
1056      1567 1020      LDA I
1057      1570 0037      37
1060      1571 7643      JMP QAEXIT+2   /LEGAL EXIT
1061
1062      1572 1461      SAE I 1
1063      1573 7641      JMP QAEXIT     /ILLEGAL
1064
1065      1574 7643      JMP QAEXIT+2   /ALT
1066      /EXIT, DONT ECHO
1067
1067      1575 1000      QALEGL, LDA
1070      1576 1536      QATY
1071      1577 7650      JMP QATPE      /ECHO CHAR
1072      1600 3536      ADD QATY
1073      1601 1560      BCL I          /STRIP IT TO 6-BIT
1074      1602 7700      7700
1075      1603 7643      JMP QAEXIT+2
1076
1077      1604 1460      /TO HERE IF CONTROL CHAR
1100      1605 7755      QACNTR, SAE I
1101      1606 7621      7755
1102      1607 1020      JMP QACKLF
1103      1610 0043      LDA I          /CR
1104      1611 5642      43
1105      1612 1020      STC QAEXIT+1
1106      1613 0215      LDA I
1107      1614 7650      215
1110      1615 1020      JMP QATPE
1111      1616 0212      LDA I
1112      1617 7650      212
1113      1620 7641      JMP QATPE
1114      /JMP QAEXIT
1115      1621 1460      QACKLF, SAE I
1116      1622 7752      7752
1117      1623 7627      JMP .+4
1120      1624 1020      LDA I          /LF
1121      1625 0045      45
1122      1626 7611      JMP QACNTR+5
1123      1627 1460      SAE I          /CNTRL R SEEN ?
1124      1630 7762      7762
1125      1631 0456      SKP
1126      1632 7672      JMP QAA0
1127      1633 1460      SAE I
1130      1634 7751      7751
1131      1635 7641      JMP QAEXIT     /ILLEGAL
1132      1636 1020      LDA I
1133      1637 0047      47
1134      1640 7643      JMP QAEXIT+2   /EXIT, DONT ECHO
1135      /
1136      1641 1020      QAEXIT, LDA I  /GET 6-BIT ASCII
1137      1642 0000      0
1140      1643 0061      SET I 1        /RESTORE XRS
1141      1644 0000      0
1142      1645 0062      SET I 2
1143      1646 0000      0
1144      1647 6000      JMP            /EXIR S\R GETKBD
1145      /S\R TO PRINT C(AC)
1146      1650 0500      QATPE, IOB
1147      1651 6046      QATLS         /PDP-8 IOT TLS
1150      1652 1000      LDA
1151      1653 0000      0
1152      1654 5660      STC .+4       /SAVE RETURN
1153      1655 0500      IOB

```

```

1154      1656  6041      QATSF  /WAIT FOR FLAG
1155      1657  7655      JMP  ,=2
1156      1660  6000      JMP   /EXIT
1157
1160      1661  0243  QACHAR, 243  /HASH
1161      1662  0244  244    /DOLLAR SIGN
1162      1663  0245      245    /PER CENT
1163      1664  0247      247    /APOSTROPHE
1164      1665  0300      300    /AT SIGN
1165      1666  0336      336    /UP ARROW
1166      1667  0337      337    /BACK ARROW
1167      1670  0040      40    /RUBOUT
1170      1671  0036      36    /ALT
1171
1172      1672  0604  /END OF S\R GETKBD
1173      1673  7424  QAA0,  LIF 4
1174      1674  0623      JMP QAA1      /CNTRL R EXIT
1174      1675  2522
1174      1676  0540
1174      1677  7740
1174      1700  7461
1174      1701  3400
1174      DSPNEW, TEXT QFSURE ? <1\0

```

NO ERRORS

AC VALZ 4036
AD SBLK 0515
AD SBMP 0503
AD SSP 0467
AD SSPA 0617
AD SSPX 0626
AD SSP1 0505
AD SSP2 0557
AD SSP3 0572
AD SSP4 0567
AD SSP5 0565
AD STMP 0465
AD VRT 4654
AD V1 6 4635
AD V1 6A 4644
AD V1 6B 4651
ANSWER 2022
BAS LIN 0026
BMULT 5310
BMULTR 5357
BMULTS 5355
BMULT1 5307
BMULT2 5320
BOUND 571 6
BUFB0 0400
BUFB4 0400
BUFHI 5774
BUFLO 5775
BUFPTR 5704
BUMPR 0045
BUMPR1 0046
BXRET 4041
B1 1423
B2 1426
B3 1432
B4 INTB 1056
B6CALL 4020
=

B6FRB0 0415
CDF0 5601
CHBANK 5373
CHKHI 5673
CKTP 0116
CKTPB 0127
CKTPIN 0107
CLLDRA 4075
CLRCRV 1124
CLRMOR 1133
CLRT 1136
COMMIS 0036
COMPR 4601
COMPRT 4612
COMPR1 4604
COMPR2 4613
CONT 5600
CORVAL 0023
COUNT 0025
CR 4043
CSAM 5552
CURCNT 5773
CURDIS 5751
CURL0P 5763
CURRTN 5650
CURSAM 0101
C1 1436
DADD 5704
DBLHI 5741
DBLLO 5747
DECML 4430
DECMLA 4446
DECMLB 4455
DECMLC 4466
DECMRM 4414
DECMRT 4463
DELSP 0415
DELSPA 0425
DELSPC 0432
DELSRT 0424
DIAL77 0040
DORAGO 1106
DORART 1104
DORG01 1137
DORG03 1167
DORG04 1206
DORG05 1222
DORG06 1230
DORG07 1233
DORG08 1221
DOSUB 0053
DREND 4071
DRSTR 4066
DSCALL 2020
DSCLOC 5445
DSCLOP 5476
DSCWD 5462
DSPERA 2657
DSPERB 2656
DSPNEW 3674
DSP1 2026
DSP1P1 2167
DSP1P2 2201

DSP1P3 2246
DSP1P4 2275
DSP2 2053
DSP2P1 2336
DSP2P2 2431
DSP3 2102
DSP3P1 2444
DSP3P2 2515
DSP4P1 2560
DSP4P3 2642
ENDHI 5777
ENDLO 5776
ERAST 0106
ERNUU 0731
ERNNX 0726
ERRCXX 2663
ERRNW0 1501
ERRNW1 1504
ERRNW9 1514
ERR1 1447
ERR2 1455
ERR2A 1462
ERR3 1463
ERTABL 1426
ER0 0242
ER0A 0247
ER0B 0255
ER0C 0172
ER1 0164
ER1A 0173
ER1B 0226
ER1C 0240
ER2 0261
ER2A 0263
ER2RTN 0304
ER2SRT 0350
ER2S1 0307
ER2S2 0317
ER2S3 0330
E1 1503
FLAGWD 0051
FLDZ0 0017
FNDAD 0516
FNDAD1 0525
FNDAD2 0527
FNDAD3 0544
FNDRT 5171
FNDSPB 5155
FNDSPC 5201
FRESAM 0105
FSTBLK 0103
FTEMP 1263
F1 1264
F2 1351
F2ZXQ 1331
F3 1342
F4 1353
F5 1354
GETANS 5237
GETKBD 3521
GOPRT 4137
GTANS1 5251
G1 1356

HELPO5 0747
HELPR1 0763
HELPR2 0753
HELPR3 0752
IDORA 5400
ILLG 1764
ILLGL 1745
ILLGL1 1754
INITDL 0026
INSRT 0454
INSRTA 0457
INSRTN 0464
INSTNM 0101
INTDRA 4061
INTP 0131
INTPA 0134
INTPB 0142
INTTBL 1241
IPCR1 1200
IPCSUB 1161
JMPSUB 4037
JMPTBL 1252
JMQR 4045
JMQR 4046
KBUFHI 5441
KBUFL0 5442
KEEPDR 1346
KIDORA 4057
KMNADR 5436
KMNFLD 5435
KMXADR 5440
KMXFLD 5437
KRDORA 4060
KYSCAL 5443
LBDATA 1052
LBPR 0362
LBPRA 0371
LBPRB 5020
LBPRC 5117
LBPRD 5124
LBPRE 5137
LBPRF 1054
LBPRG 1100
LBPRRT 0370
LBPRX 5114
LBPRZ 1102
LBPR4 1475
LEGAL 1014
LEGAL1 1031
LF 4042
LFUNIT 1033
LIFX 4040
MATCH 0441
MATCHB 0460
MATCHC 0471
MATCHD 0501
MATCHE 0506
MATCHF 0436
MAXADR 5675
MAXFLD 5674
MINADR 5616
MINFLD 5615
MINUS1 1371
=

MISSES 0033
MNLNER 0764
MNLNE1 0773
MORP2 1373
MORP3 1401
MORP4 1413
MORP5 1415
MTHRT 0477
MULACV 5255
MULTMP 5254
MULT10 5256
MULT8 5274
MULT8E 5360
MVRT 4634
MV16 4626
MV16A 4631
M1 4427
M1A 4514
M1S 4504
M1THS 4424
M10 4426
M100 4425
M1000 5727
M2 0104
M70 5676
NAMETP 0050
NOMORE 1472
NOTUNQ 1761
NUMDIS 0052
NUMPAR 0100
NUMPRA 0027
NUMPTS 4056
NUMPT0 0024
NUMPT4 0077
NXTDF 5666
NXTPNT 5641
OFFSET 0025
OF12BU 4000
OKEND 5663
OKFLD 5667
O1 1467
PARA 0073
PARA0 0044
PARDAT 0020
PASTRT 0545
PASTSP 0535
PASTS1 0550
PLUS1 1420
PLUS2 4052
PM1 0666
PONE 0622
POS5 1314
PRCNT1 0040
PRCT1 0052
PRCT2 0054
PRCT3 0056
PREAD 0042
PRLF 4201
PRLFA 4205
PRLFRT 4216
PRMTRS 4047
PRNTCH 4127
PRNTLA 4115

PRNTLN 4112
PRNTPC 4126
PRNT1 1525
PROCMD 1210
PRTABL 1330
PRT1 1350
PRT2 1375
PTCMA 0753
PTCMRT 0630
PTCM1 0557
PTCM2 0565
PTCM3 0571
PTCM4 0602
PTCM5 0621
PTCM6 0510
PTFAIL 0631
PTFALB 0743
PTFALC 0700
PTFALD 0647
PTFALE 0654
PTFALH 0705
PTFALJ 0712
PTFALK 0720
PTFALL 0732
PTFALP 0770
PTFAQ 0636
PTR14B 1002
PTSCVD 0037
PTSLIB 0034
PTSUNK 0035
PTZA 1005
PTZAR 1013
PTZAR1 1025
PTZA1 1014
PWRITE 0043
P1 4054
P184 0105
P100 4044
P12 0043
P16 5173
P2 4766
P3 4053
P3777 0063
P4 5234
P40 0776
P4000 4051
P401 5444
P5 0734
P6 1564
QAA0 3672
QAA1 1424
QAB 3004
QACA 3015
QACHAR 3661
QACKLF 3621
QACNTR 3604
QAD 3026
QAE 3050
QAEXIT 3641
QAF 3516
QAG 3062
QAH 3114
QAI 3131

QAINIT 3000
QAJ 3136
QAK 3305
QAKRB 6036
QAL 3175
QALEGL 3575
QAM 3101
QAN 3223
QAO 3231
QAP 3242
QAQ 3263
QARFSH 3053
QAT 3270
QATLS 6046
QATPE 3650
QATSF 6041
QATY 3536
QAU 3506
QAV 3316
QAW 3512
QAX 3424
QAY 3412
QAZ 3301
QRD 0064
QWT 0065
RDORA 5544
ROTAPE 4150
ROTPRT 4171
READ 7774
RETTY 4726
RETURN 6000
RSTRY 5172
RTN 0041
RTNCOF 5460
RWTAPE 4172
R0 1442
R1 1443
R2 1463
R9 1462
SCALE 0340
SC12BU 0343
SETDF 5741
SETFLD 5632
SETSHV 1152
SET16 4616
SHOVE 0777
SHOVEA 1002
SHOVER 1013
SHOW12 1037
SHOW14 1041
SHOW3 1035
SHOW41 1047
SHVSB1 1251
SHW21M 1045
SIGR 1374
SINGL 1353
SPCCST 0063
SPSP 4055
SPSPA 0042
STDIAL 1470
STDOR 1157
STDORX 1260
STDORZ 1201

STDOR3 1204
STDOR4 1225
STDOR5 1237
STDOR6 1261
STERR 1433
STPRT 1334
STRLF 5203
STRLFB 0447
STRLFC 5217
STRT 1066
STRTA 1101
STRTB 1127
STRTC 1135
STRTPA 5223
STRTRT 5233
STRT2 1112
STTAB 1051
TAB 5524
TAPEZ 4155
TAPEZ1 4164
TEMP 5477
TEMP1 4050
TLRNCE 0030
TRABRT 4266
TRANS 4230
TRANSA 4233
TRANSB 4244
TRDTA 5007
TRDTAR 5017
TRDTA1 5012
TRNMD1 4235
TRNMD2 4271
TRNSMD 4217
TRNSMT 4227
TRNSRT 4243
TXTSTR 2021
TYA 4267
TYANA 1634
TYANS 1604
TYAN1 1606
TYAN1A 1607
TYAN1B 1623
TYAN1C 1627
TYAN1F 1621
TYAN3 1632
TYAN3B 1643
TYAN3C 1656
TYAN3D 1664
TYAN3E 1671
TYAN4 1674
TYAN4A 1675
TYAN4B 1703
TYAN4C 1711
TYAN4D 1716
TYAX 4402
TYAY 4367
TYAY1 1400
TYAY2 1406
TYAY5 4372
TYAZ 4404
TYA1 4310
TYA2 4313
TYA3 4323

TYA4	4353
TYA4A	4357
TYB	4531
TYB1	4573
TYB2	4556
TYC	0351
TYCA	0357
TYCNT	4735
TYCSB	4661
TYCSB1	4665
TYC1	4655
TYC1A	4671
TYC1B	4722
TYC1C	4736
TYC1D	4743
TYC1E	4746
TYC1F	4762
TYC1M	4675
TYC1N	4711
TYC1X	4707
TYC2	4727
TY01	2705
TY02A	2745
TY03	2714
TY04	2723
TY05	2752
TY06	1717
TY07	1522
TY07A	1532
TY08	1543
TY08A	1554
TY09	1557
TY09A	1570
TY09B	1576
TY09C	1603
UA	1660
UARET	1674
UB	1675
UC	1672
UNKVAL	0044
U1	1603
U1A	1565
U1AA	1571
U1ARET	1602
U2	1627
U3	1636
U4	1700
U7	1726
U8	0743
U9	1744
VCOORD	5475
V1	5005
V2	0664
V4	4420
WINSAM	0100
WRAP	5624
WRITE	7775
WSAM	5561
WTTAPE	4173
WTUN0	5566
XCORD	0001
XCURHI	0021
XCURLO	0022

XNMBUF 0060
XNMRET 1051
XNMTMP 0062
XNUM 1026
XNUMA 1032
XNUMB 1036
XWORD 0047
XWORD1 0050
XXCRD 5564
X1 1510
X12 4520
X2 0707
X22 4524
X3 0721
X32 4526
X4 1524
YCUR 0024
YOFFST 4072
YQ1 0665
YSCAL 5644
YSCALE 4073
YSCRNG 1366
YSCTMP 1370
YSHFT 0020
Z6 0674
Z7 4344

HOW TO OBTAIN SOFTWARE INFORMATION

Announcements for new and revised software, as well as programming notes, software problems, and documentation corrections are published by Software Information Service in the following newsletters.

Digital Software News for the PDP-8 & PDP-12
Digital Software News for the PDP-11
Digital Software News for the PDP-9/15 Family

These newsletters contain information applicable to software available from Digital's Program Library. Articles in Digital Software News update the cumulative Software Performance Summary which is contained in each basic kit of system software for new computers. To assure that the monthly Digital Software News is sent to the appropriate software contact at your installation, please check with the Software Specialist or Sales Engineer at your nearest Digital office.

Questions or problems concerning DEC software should be reported to the Software Specialist. In cases where no Software Specialist is available, please send a Software Performance Report form with details of the problem to:

Software Information Service
Digital Equipment Corporation
146 Main Street, Bldg. 3-5
Maynard, Massachusetts 01754

These forms which are available without charge from the Program Library, should be fully filled out and accompanied by Teletype output as well as listings or tapes of the user program to facilitate a complete investigation. An answer will be sent to the individual and appropriate topics of general interest will be printed in the newsletter.

New and revised software and manuals, Software Performance Report forms, and software price lists are available from the Program Library. When ordering, include the document number and a brief description of the program or manual requested. Revisions of programs and documents will be announced in the newsletters. Direct all inquiries and requests to:

Program Library
Digital Equipment Corporation
146 Main Street, Bldg. 1-2
Maynard, Massachusetts 01754

Digital Equipment Computer Users Society (DECUS) maintains a user library and publishes a catalog of programs as well as the DECUSCOPE magazine for its members and non-members who request it. For further information please write to:

DECUS
Digital Equipment Corporation
146 Main Street, Bldg. 3-5
Maynard, Massachusetts 01754

READER'S COMMENTS

Digital Equipment Corporation maintains a continuous effort to improve the quality and usefulness of its publications. To do this effectively we need user feedback -- your critical evaluation of this manual.

Please comment on this manual's completeness, accuracy, organization, usability, and readability.

Did you find errors in this manual? If so, specify by page.

How can this manual be improved?

Other comments?

Please state your position. _____ Date: _____

Name: _____ Organization: _____

Street: _____ Department: _____

City: _____ State: _____ Zip or Country _____

Fold Here

Do Not Tear - Fold Here and Staple

FIRST CLASS
PERMIT NO. 33
MAYNARD, MASS.

BUSINESS REPLY MAIL
NO POSTAGE STAMP NECESSARY IF MAILED IN THE UNITED STATES

Postage will be paid by:

digital

Digital Equipment Corporation
Software Information Services
146 Main Street, Bldg. 3-5
Maynard, Massachusetts 01754

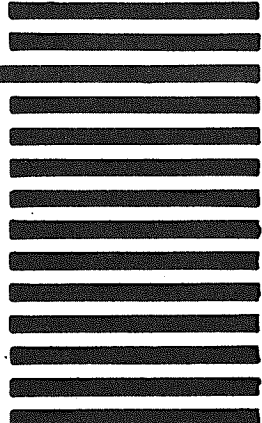

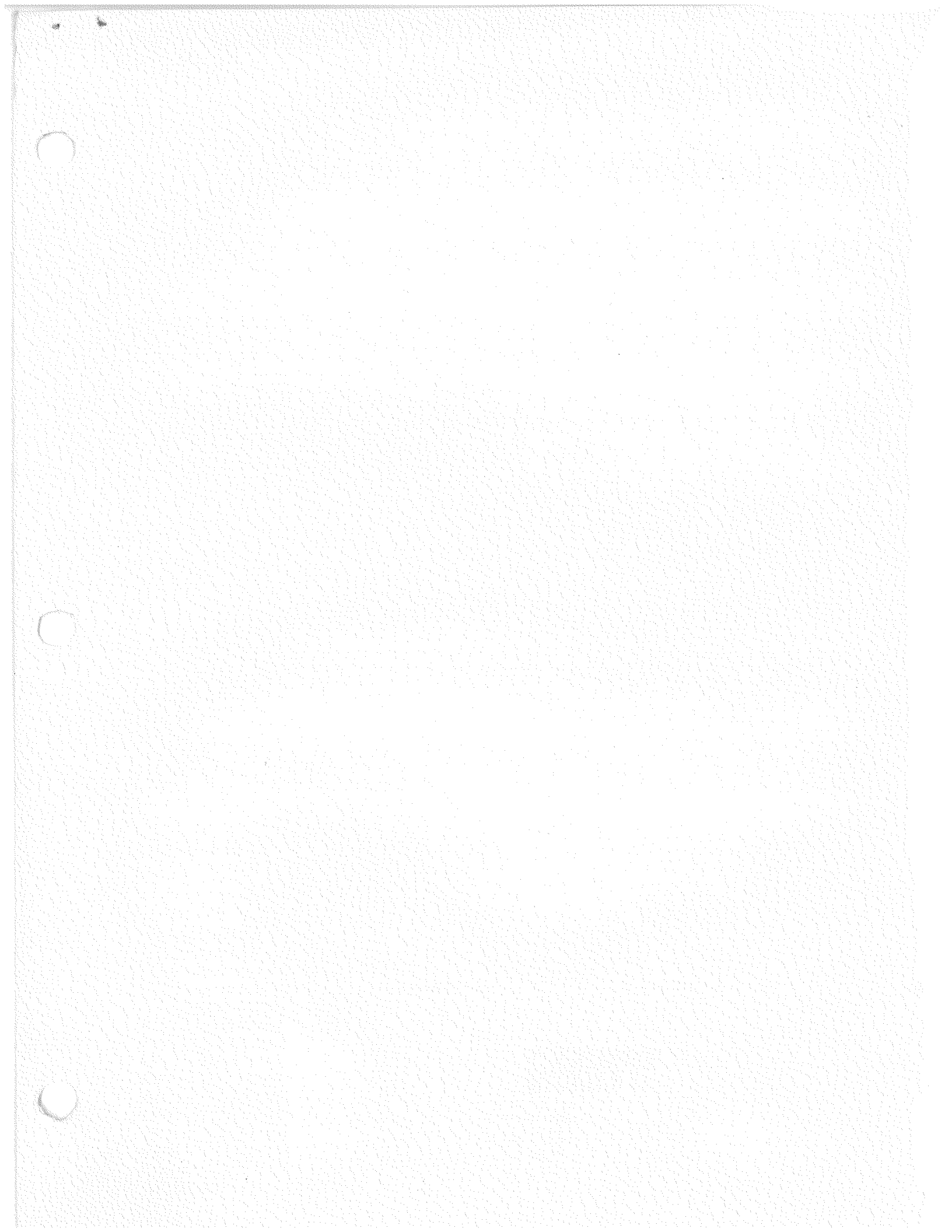

**Digital Equipment Corporation
Maynard, Massachusetts**

digital

printed in U.S.A.