

**KP8-E power-fail
& auto-restart
engineering drawings**

This drawing and specifications herein are the property of Digital Equipment Corporation and shall not be reproduced or copied in whole or in part as the basis for the manufacture or sale of items without written permission. COPYRIGHT © 1973 DIGITAL EQUIPMENT CORPORATION

NOTES:

1. FOR FIELD INSTALLATION:
 - A. PLUG BOARD INTO OMNIBUS.
 - B. IF THERE ARE NO CONNECTIONS TO J5 ON THE 724 POWER SUPPLY OR J1 (OPTION CONNECTOR) ON THE B/F & B/M POWER SUPPLIES, INSTALL THE RED LEAD INTO THE CENTER POSITION ON THE 3 CONTACT MATE-N-LOCK CONNECTOR, THEN INSTALL THE 2 WHITE LEADS IN THE 2 REMAINING POSITIONS.
 - C. IF THE PROCESSOR HAS MORE THAN ONE OPTION THAT USES THE "OPTION CONNECTOR" (J1, B/M, B/F OR J5 (B/E)) THE MODULES WILL BE CONNECTED IN PARALLEL TO THE POWER SUPPLY IN THE FOLLOWING MANNER: INSERT THE PINS FROM THE "POWER SUPPLY END" OF THE M848'S CABLE INTO THE VACANT SOCKETS OF THE "OTHER OPTIONS" EIGHT PIN MATE-N-LOCK USING THE TABLE TO THE RIGHT (CONTINUED ON PAGE 2)

WIRE COLOR	PIN #
RED	445
WHITE	142
WHITE	748

REF	DESIGNATION	DESCRIPTION	PART NO.	ITEM NO.
REF		X-Y COORDINATE HOLE LOCATION	K-CO-M848-0-4	1
REF		ASSY/DRILLING HOLE LAYOUT	D-M848-0-5	2
REF		MODULE E.C.O. HISTORY	B-M848-0-6	3
1		ETCHED CIRCUIT BOARD	5009392	4
1	C26	CAP 68 PF 100V 5%	1000014	5
1	C24	CAP 220 PF 100V 5%	1000021	6
1	C25	CAP 3.9 UF 10V 10%	1000084	7
1	C34	CAP 39 UF 10V 10%	1000076	8
1	C23	CAP 68 UF 15V 10%	1000082	9
1	C33	CAP 180 UF 6V 20%	1000086	10
21	C1-C18, C28, C29, C32	CAP .01 UF 100V 20%	1001610	11
1	C27	CAP 27 PF 100V 5%	1001739	12
2	C30, C31	CAP 1 UF 35V 10%	1001776	13
1	C22	CAP 15 UF 20V 10%	1004812	14
3	C19-C21	CAP 6.8 UF 35V 10%	1005306	15
5	D8, D9, D10, D13, D11	DIODE D664	1100114	16
8	D1-D7, D14	DIODE D672	1105275	17
1	D12	DIODE 1N754A ZENER	1109991	18
4		SPACER (CABLE CLAMP)	1202704	19
1	J1	PIN HOUSING(MATE-N-LOCK)	1209340	20
8		PIN SOCKET (MATE-N-LOCK)	1209456	21
1	S1	SWITCH TOGGLE	1210209	22
3	R17, R19, R42	RES 100 1/4W 5%	1300229	23
3	R50, R8, R2	RES 470 1/4W 5%	1300316	24
6	R5, R6, R11, R14, R25, R28	RES 1K 1/4W 5%	1300366	25
5	R48, R26, R29, R27, R30	RES 1.5K 1/4W 5%	1300391	26
2	R49, R43	RES 3.3K 1/4W 5%	1300439	27
2	R4, R7	RES 4.7K 1/4W 5%	1300447	28
4	R3, R12, R13, R18	RES 10K 1/4W 5%	1300479	29
4	R9, R15, R16, R10	RES 27 1/4W 5%	1301522	30
1	R53	RES 6.8K 1/4W 5%	1301423	31
1	R1	RES 47K 1/4W 5%	1302177	32
1	R32	RES 511 1/8W 1%	1302411	33
1	R54	RES 46.4 1/2W 1%	1302590	34
1	R52 (SEE NOTE 5)	RES 80 1/8W 1% MF	1302961	35
1	R36	RES 464 1/8W 1%	1303047	36
1	R33	RES 75 1/8W 1%	1303064	37
1	R47	RES 422 1/8W 1%	1303087	38
4	R21, R22, R34, R40	RES 1K 1/8W 1%	1303114	39
1	R31	RES 21.5K 1/8W 1%	1303155	40
1	R37	RES 10K 1/8W 1%	1303312	41
1	R55	RES 10 1/8W 1%	1303378	42
1	R46	RES 1.96K 1/8W 1%	1304833	43
1	R23	RES 3.65K 1/8W 1%	1304835	44
1	R38	RES 237 1/8W 1%	1304857	45
1	R41	RES 348 1/8W 1%	1304858	46
1	R20	RES 3.48K 1/8W 1%	1305114	47
1	R44	RES 5.82K 1/8W 1%	1305128	48
1	R45	RES 68.1K 1/8W 1%	1306252	49
2	R35, R51	POT 100 3/4W 78PPR	1308143-04	50
1	R24	RES 3.83K1/8W 1%	1309413	51
1	R39	RES 249 1/8W 1%	1309787	52
2	Q6, Q7	TRANS. DEC 6534B	1503409-01	53
6	Q1-Q5, Q8	TRANS DEC 6531B	1508338	54

QTY	REF DESIGNATION	DESCRIPTION	PART NO.	ITEM NO.

IC TYPE	GND	+5V
DEC 7475	12	5
DEC 6314	1	8
DEC 6380	1	8
DEC 384	1	8

GND AND 5V ARE USUALLY PIN 7 AND 14 RESPECTIVELY. EXCEPTIONS ARE STATED ABOVE.

IC PIN LOCATIONS

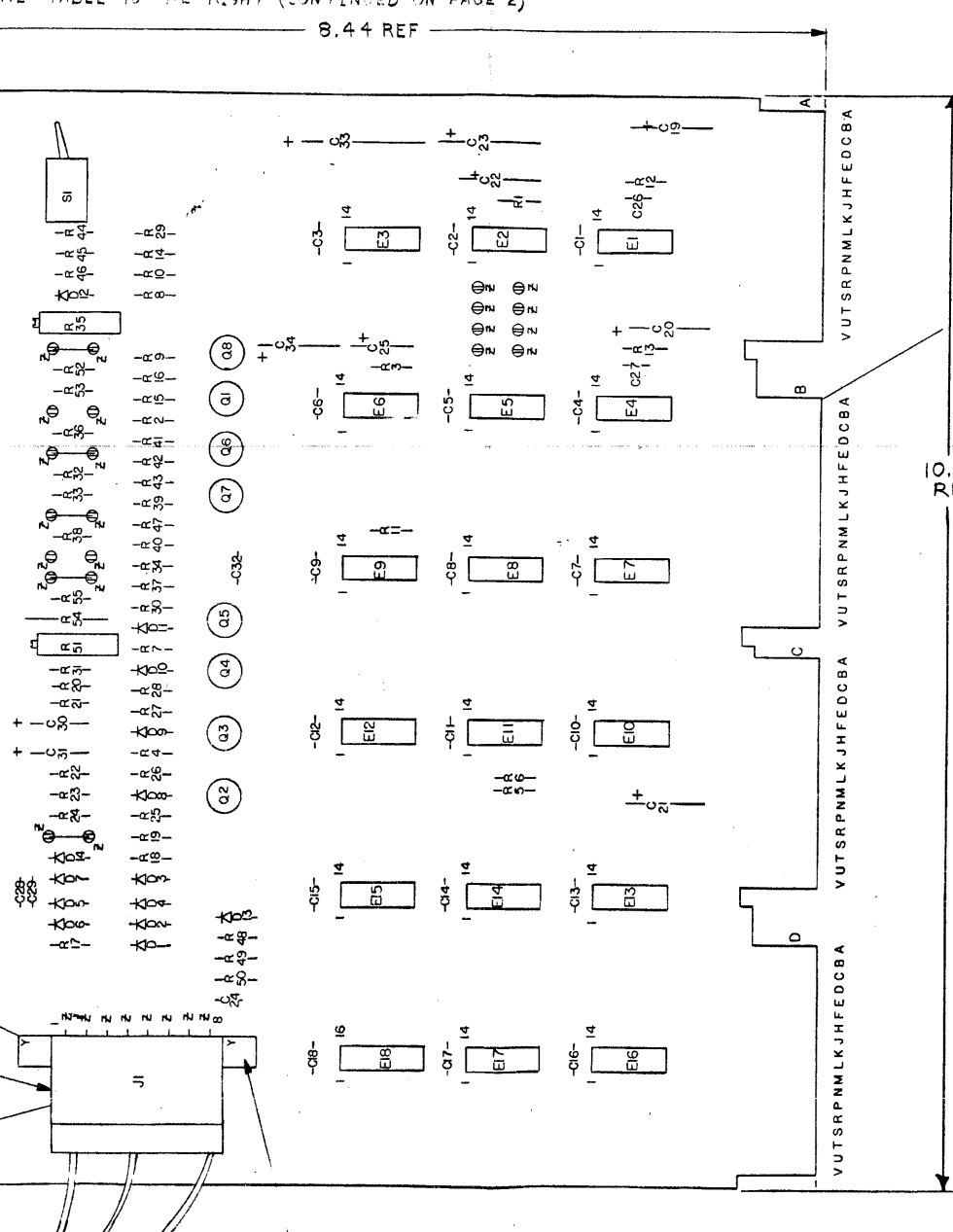

REV	CHG	NO.	REV
1			

DCS M848-0-1

digital EQUIPMENT CORPORATION
MAYNARD, MASSACHUSETTS

TITLE: **POWER FAIL & AUTO RESTART**

SIZE CODE: DCS M848-0-1
NUMBER: T
REV: T

SEMICONDUCTOR CONVERSION CHART

"THIS DRAWING AND SPECIFICATIONS, HEREIN, ARE THE PROPERTY OF DIGITAL EQUIPMENT CORPORATION AND SHALL NOT BE REPRODUCED OR COPIED OR USED IN WHOLE OR IN PART AS THE BASIS FOR THE MANUFACTURE OR SALE OF ITEMS WITHOUT WRITTEN PERMISSION. COPYRIGHT © 1973, DIGITAL EQUIPMENT CORPORATION"

NOTES:
 2. REMOVE JUMPER W2 FOR PDP 8/M & 8/F
 3. TO RESTART IN ANOTHER ADDRESS INSTALL ONE JUMPER PER TABLE BELOW:

JUMPER	D0	D1	D2	D4
ADD 4000	X			
ADD 2000		X		
ADD 1000			X	
ADD 0200				X

TO RESTART IN LOCATION 0 NO JUMPER REQUIRED. DO NOT INSTALL MORE THAN ONE JUMPER IN D0 THRU D4.
 4. IF THE LINE VOLTAGE IS OTHER THAN 115 OR 230 VAC, MOVE THE LINE VOLTAGE JUMPERS ACCORDING TO THE NOMINAL LINE VOLTAGE WHERE THE COMPUTER IS OPERATING. SEE TABLE BELOW FOR JUMPER POSITIONS.

LINE VOLTAGE	ADD JUMPERS (2 PLACES)	REMOVE JUMPERS (2 PLACES)
115 OR 230 VAC	115/230 & 240	220
220 VAC	220 & 240	115/230
240 VAC	115/230	240 & 220

DO NOT UNDER ANY CIRCUMSTANCES ATTEMPT TO CHANGE OR ADJUST THE POTENTIOMETERS ON THIS BOARD. THESE POTS ARE FACTORY SET AND WILL NOT NEED READJUSTING AT ANY TIME.

COMPONENT SUBSTITUTION CHART

ORIGINAL PART	1ST SUB	2ND SUB	3RD SUB
IC 6380 19-09971	11380 19-11113	380 19-09985	5380 19-10392
IC 6314 19-09972	314 19-09704	5314 19-10391	
IC 8881 19-09705	97401 19-09973		

5. R52 MAY BE EITHER A 80 OHM 1/8W 1% OR AN 80.6 OHM 1/8W 1% METAL FILM RESISTOR

QTY	REF	DESIGNATION	DESCRIPTION	PART NO.	ITEM NO.
2	E8, E9		I.C. DEC 7474	1905547	55
1	E5		I.C. DEC 7400	1905575	56
1	E17		I.C. DEC 7410	1905576	57
1	E12		I.C. DEC 7402	1909004	58
1	E18		I.C. DEC 7475	1909050	59
4	E1, E2, E4, E6		I.C. DEC 9601	1909373	60
2	E11, E16		I.C. DEC 384	1909486	61
3	E3, E14, E15		I.C. DEC 8881	1909705	62
2	E7, E13		I.C. DEC 6380	1909971	63
1	E10		I.C. DEC 6314	1909972	64
REF			POWER CABLE	D-1A-7007128-0-0	65
2			KEEP NUT #4-40 SST	9006557	66
2			SCR PHL HD PAN #4-40 x 5/16 LG	9006010-1	67
2			WASHER FLAT #4 NYLON	9006706	68
22			SPLIT LUGS	9006735	69
8			EYELETS	9006750	70
4			HANDLE FLIP CHIP MAGENTA	9008337-06	71
A/R			WIRE #22 AWG BAS	9107560-01	72

REVISIONS		
CHK	CHANGE NO	REV.

TITLE	SCALE	SHEET	OF	DIST.	SIZE	CODE	NUMBER	REV.
POWER FAIL & AUTO RESTART	NONE	2	OF 3		D	CSM848-0-1		T

REV. T
NUMBER: DCSM848-0-1

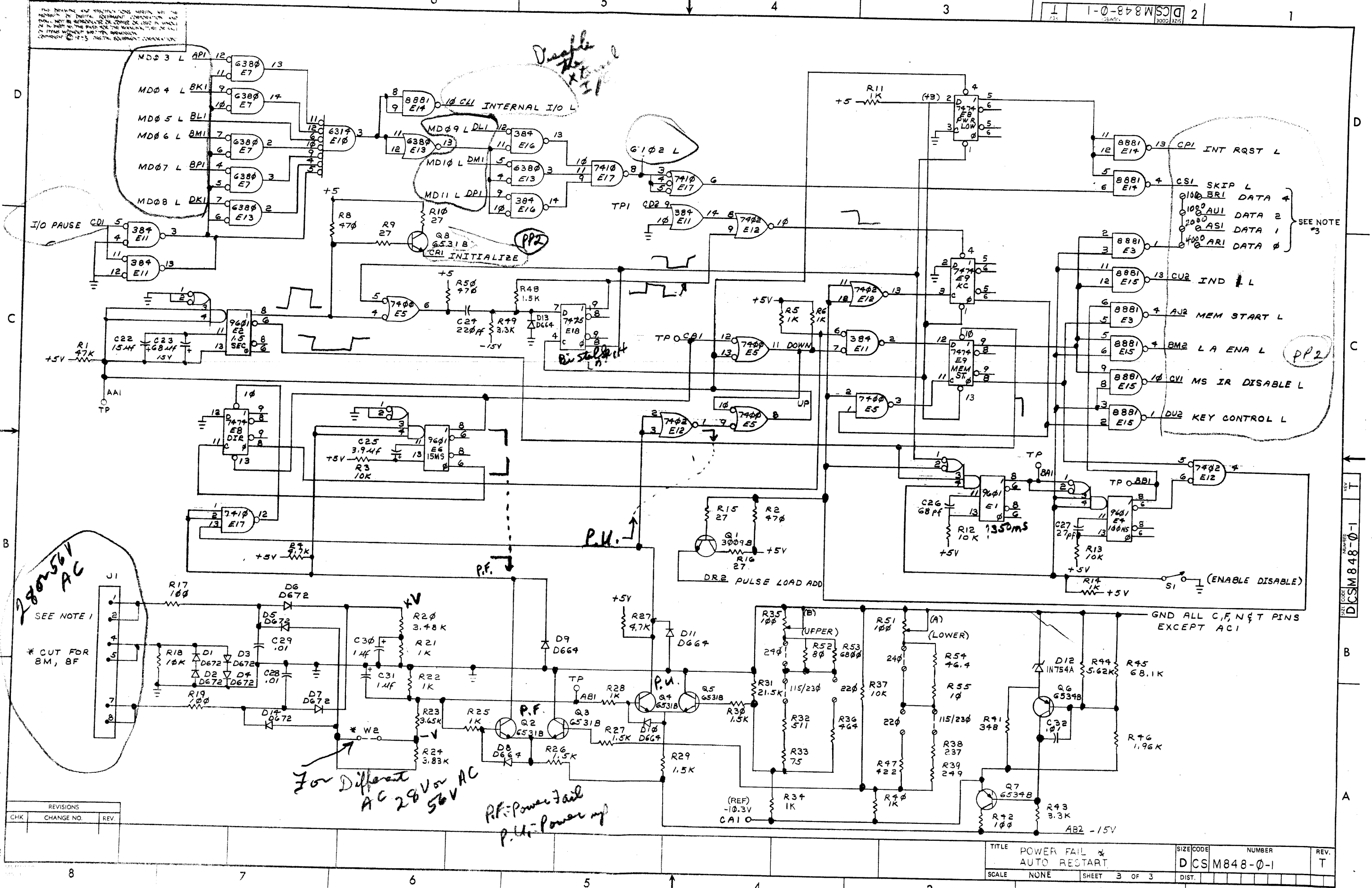

REVISIONS		
CHK	CHANGE NO.	REV.

TITLE	POWER FAIL & AUTO RESTART	SIZE CODE	DCSM848-0-1	NUMBER	1	REV.	T
SCALE	NONE	SHEET	3 OF 3	DIST.			

This drawing and specifications, herein, are the property of Digital Equipment Corporation and shall not be reproduced or copied or used in whole or in part as the basis for the manufacture or sale of items without written permission.

DIGITAL EQUIPMENT CORPORATION
MAYNARD, MASSACHUSETTS

ENGINEERING SPECIFICATION

DATE 7/9/71

TITLE POWER FAIL AND AUTO-RESTART, KP8/E

REVISIONS

REV	DESCRIPTION	CHG NO	ORIG	DATE	APPD BY	DATE
A	REVISED & RETYPED	00001	L.NARHI	7-16-71	LNA	

*PWR DOWN
PWR LOW
INT RQST
JMS → IR
OPPR → CPMA
EXECUTE → M.S.*

103/5150

Power Down

0000	PC	
0001	DCA100	3100
0002	GTF	6004
0003	DCA 101	3101
0004	JMP20	5020
0020	SPL	6102
0021	SKP	7410
0022	JMP50	5050
0050	TAD 0000	1000
0051	DCA 102	3102
0052	TAD 103	1103
0053	DCA 0	3000
0054	HLT	7402

Power UP

0000	JMP 150	5150
150	TAD 101	1101
151	RTF	6005
152	CLA	7200
153	TAD	1100
154	JMPI 102	5502

KEY SET	MEM ST SET	PASS #2 KEY CLEAR / MEM ST SET	IND 1L LAENA L MS IR DIS L	KEY CONTROL L	IND 1L LAENA L MS IR DIS L
				0000 → IF	
				0000 → DF	

PASS #3 KEY CLEAR	MEM START CLEAR	IND 1H LAENA H MS I DIS H

MEM START L

ENG Larry Narhi	APPD R.K. ALLEN	SIZE A	CODE SP	NUMBER KP8-E-1	REV A
--------------------	--------------------	-----------	------------	-------------------	----------

ENGINEERING SPECIFICATION

TITLE POWER FAIL AND AUTO-RESTART, KP8/E

1. Overall Description

Power fail and auto-restart is an option to the PDP8/E computer which, when properly programmed, prevents the loss of the contents of the active registers in the computer in the event of an AC power failure. When AC power is restored, this option restarts the computer at memory location 0.

2. General Specifications

2.1 The KP8-E option consists of one 8½" Quad module, M848, which plugs directly into the PDP8/E Omnibus and also must be connected to the 28V AC source in the PDP8/E power supply.

2.2 Jumpers on the board allow the user to select power line thresholds where the computer shuts down or restarts.

Line	120V AC Upper/Lower	230V AC Upper/Lower	Install Jumpers
High	105/95	190/170	A & D
Normal	90/80	175/155	B & E
Low	80/70	160/140	C & F

The upper threshold restarts the computer while the lower threshold sets the Power Low flag which generates an Interrupt Request.

2.3 Operating Temperature : 0°C to 55°C
Relative Humidity : 10 to 90%, non-condensing

2.4 Power Required:

+5.0V	-	700 MA
-15.0V	-	15 MA
28V AC	-	7 MA

SIZE A	CODE SP	NUMBER KP8-E-1	REV A
-----------	------------	-------------------	----------

TITLE POWER FAIL AND AUTO-RESTART, KP8-E

3. Programming

3.1 IOT Definition

<u>Mnemonic</u>	<u>Octal Code</u>	<u>Function</u>
SPL	6102	Skip if Power Low Flag = 1

3.2 In the interrupt service routine the SPL IOT should be first in the skip chain to keep programming time to a minimum.

3.3 When the Power Low flag is set, indicating an AC power failure has taken place, the programmer has one (1) millisecond of programming time available before the power supply levels fall below operating levels.

3.4 The enable/disable switch when in the down position, prevents the computer from restarting when power returns.

SIZE	CODE	NUMBER	REV
A	SP	KP8-E-1	A