

CUSTOMER PRINT SET		ELECTRICAL					CUSTOMER PRINT SET		MECHANICAL						
MP DKC8-AA	MFG. SET	FIND NO.	DRAWING NO.	REV	NO OF SHT	DESCRIPTION	OPTION NO./FILE DATE	MP DKC8-AA	MFG. SET	FIND NO.	DRAWING NO.	REV	NO OF SHT	DESCRIPTION	OPTION NO./FILE DATE
X		1	A-SP-DKC8-A-1	*	4	FIELD INST. & ACCEPT. PROCEDURE		X		1	A-PL-DKC8-A-0	*	1	PARTS LIST	
X			A-PL-DKC8-A-2	*	1	SHIPPING LIST									
X			A-PL-DKC8-A-3	*	1	SOFTWARE LIST									
			A-SP-DKC8-A-4		11	ENGINEERING SPEC									
X		2	D-CS-M8316-0-1	#	9	8A INTERNAL OPTION #1	M8316								
			K-CO-M8316-0-4	#	1	X-Y COORDINATE HOLE LOCATION									
			D-AH-M8316-0-5	#	1	ASSY HOLE									
			B-MH-M8316-0-6	#	1	MODULE HISTORY									
X			K-RL-M8316-0-8	#	2	ROM PATT. SPEC OPTION #1									
X			K-RL-M8316-0-9	#	2	ROM PATT. SPEC OPTION #1									

CUSTOMER PRINT SET CODES
 X = PRINT OF DOCUMENT INCLUDED IN PRINT SET
 C = INCLUDES ALL PRINTS INDICATED ON DOCUMENT
 S = CONFIDENTIAL AUTHORIZED SIGNATURE REQUIRED

TITLE: 8A INTERNAL OPTION #1
 SHEET 2 OF 2
 SIZE CODE: B DD
 NUMBER: DKC8-A
 REV:

DIGITAL EQUIPMENT CORPORATION
MAYNARD, MASSACHUSETTS

ENGINEERING SPECIFICATION

TITLE FIELD INSTALLATION & ACCEPTANCE PROCEDURE FOR DKC8-A DATE 11/19/74

REVISIONS				
REV	DESCRIPTION	CHG NO	ORIG	DATE

This drawing and specifications, herein, are the property of Digital Equipment Corporation and shall not be reproduced or copied or used in whole or in part as the basis for the manufacture or sale of items without written permission.

ENG *J. M. ...* APPD *J. M. ...* NUMBER DKC8-A-1 REV
DEC 16-(1981)-1022-N370 SHEET 1 of 4
DRA 108

ENGINEERING SPECIFICATION

TITLE FIELD INSTALLATION & ACCEPTANCE PROCEDURE FOR DKC8-A CONTINUATION SHEET

I GENERAL

This procedure defines the performance standard required of the DKC8, option board #1. This procedure refers to both system acceptance and add-on acceptance.

NOTE: If DKC8 was shipped as part of a PDP-8A system, proceed to installation procedure.

- * Serial Line Unit
- Real Time Clock
- Parallel I/O
- Programmer's Console Logic

II INSPECTION

After removing the DKC8 from the packing material, inspect the module for the following:

1. Inventory hardware against shipping list.
2. Inventory software against software list, if ordered.
3. Inventory prints against shipping list, if ordered.
4. Check hardware for loose or broken components.

III INSTALLATION PROCEDURE

Install the equipment using the following procedure:

1. Set up switches as indicated by the diagnostic write up.

SI-1 thru SI-3	"ON"	9600 baud
SI-4	"ON"	Normally "ON"
SI-5	"ON"	Real Time Clock Enable
SI-6	"ON"	Normally "ON"
SI-7	"ON"	One Stop Bit
SI-8	"OFF"	Disable TTY 20 MA Filter

NOTE: Reference Operator's Handbook for switch setting descriptions.

2. Insert TTY loop back cable (DEC Part #7008517) on DKC8.
3. Insert parallel I/O cable loop back cable (DEC Part # BC088R-1) on DKC8.

DEC FORM NO DEC 16-(1981)-1022-N370 SHEET 2 OF 4
DRA 108

ENGINEERING SPECIFICATION

TITLE FIELD INSTALLATION AND ACCEPTANCE PROCEDURE FOR DKC8-A CONTINUATION SHEET

III INSTALLATION PROCEDURE (continued)

4. Insert two programmer's console cables on DKC8.
5. Insure that the 8A Power is removed from the Omnibus™.
6. Insert DKC8 into the second or third slot of the Omnibus™.
7. Turn the power back "ON".
8. Check the operation of the programmer's console.

IV ACCEPTANCE PROCEDURE

Perform the acceptance procedure defined in Table . . . if abnormal indications are encountered, refer to the diagnostic listing for type of error. Reference the diagnostic write ups and operator's manual for instructions on loading diagnostics.

Equipment Required:

1. PDP-8A with 1K or more R/W Memory
2. Paper Tape Input Device
3. Programmer's Console (KC8-A)
4. Diagnostic and Listings
5. TTY loop Back Cable
6. Parallel I/O Loop Back Cable
7. W987 Quad Extender

NOTE: If the programmer's console and paper tape input device are not available as part of the system being used, they must be supplied in good working order by the customer.

DEC FORM NO DEC 16-(1981)-1022-N370 SHEET 3 OF 4
DRA 108

ENGINEERING SPECIFICATION

TITLE FIELD INSTALLATION & ACCEPTANCE PROCEDURE FOR DKC8-A CONTINUATION SHEET

TABLE A

Acceptance of DKC8 with 4K or More R/W Memory	Program Name	Maindec #	Accept Time Restriction
DKC8-AA Option Test #1	08-DJDKA-PB	30 min	4K R/W Memory
Acceptance of DKC8 with less than 1K of R/W Memory	DKC8-AA Option Test #1	08-DJDKA -PM1	10 min
DKC8-AA Option Test #1	Segment #1 (RIM)	08-DJDKA -PM2	10 min
DKC8-AA Option Test #1	Segment #2 (RIM)	08-DJDKA -PM3	10 min
DKC8-AA Option Test #1	Segment #3 (RIM)	08-DJDKA -PM4	10 min
DKC8-AA Option Test #1	Segment #4 (RIM)	08-DJDKA -PM4	10 min

DEC FORM NO DEC 16-(1981)-1022-N370 SHEET 4 OF 4
DRA 108

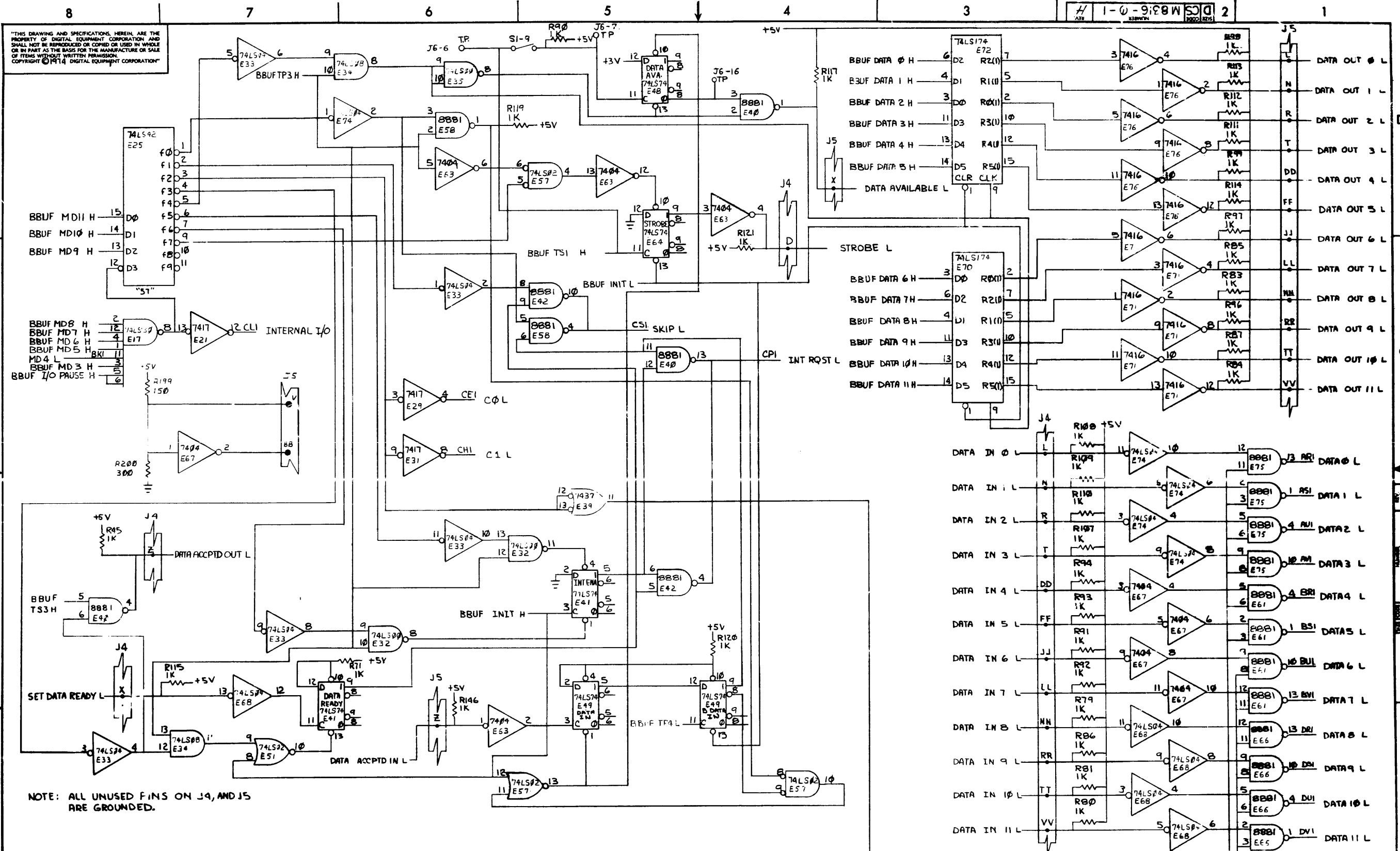

"THIS DRAWING AND SPECIFICATIONS HEREIN ARE THE PROPERTY OF DIGITAL EQUIPMENT CORPORATION AND SHALL NOT BE REPRODUCED OR COPIED OR USED IN WHOLE OR IN PART AS THE BASIS FOR THE MANUFACTURE OR SALE OF ITEMS WITHOUT WRITTEN PERMISSION. COPYRIGHT © 1974 DIGITAL EQUIPMENT CORPORATION"

NOTE: ALL UNUSED PINS ON J4, AND J5 ARE GROUNDING.

REVISIONS		
CHK	CHANGE NO.	REV.

TITLE	OPTION BD #1	SIZE	CODE	NUMBER	REV.
SCALE	1:1	SHEET	2	OF 2	D

DCS M8316-0-1

THIS DRAWING AND SPECIFICATIONS, HEREIN, ARE THE PROPERTY OF DIGITAL EQUIPMENT CORPORATION AND SHALL NOT BE REPRODUCED OR COPIED IN WHOLE OR IN PART AS THE BASIS FOR THE MANUFACTURE OR SALE OF ITEMS WITHOUT WRITTEN PERMISSION. COPYRIGHT © 1974, DIGITAL EQUIPMENT CORPORATION

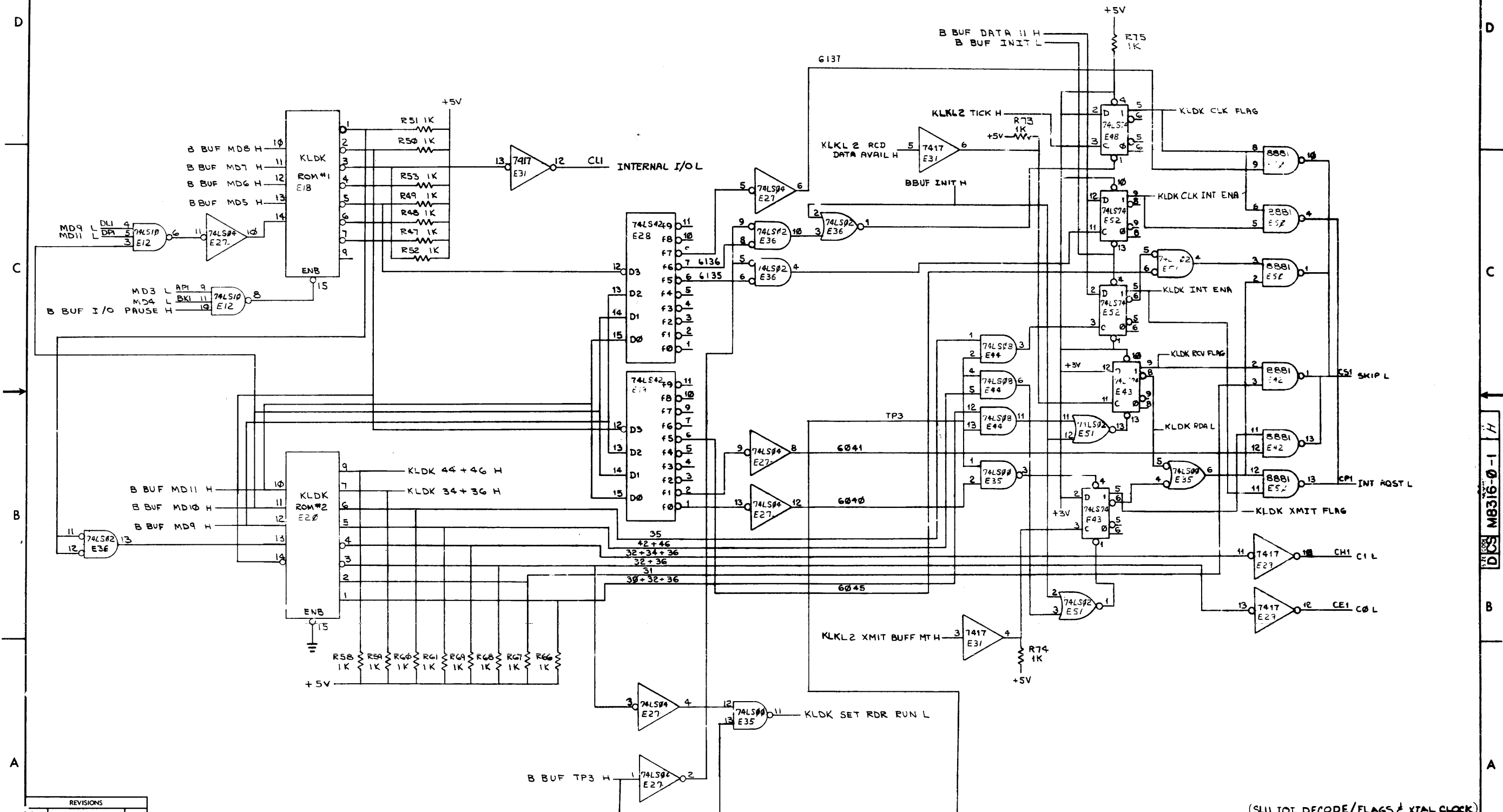

REVISIONS		
CHK	CHANGE NO	REV

(SLU IOT DECODE/FLAGS & XTAL CLOCK)

"THIS DRAWING AND SPECIFICATIONS HEREIN ARE THE PROPERTY OF DIGITAL EQUIPMENT CORPORATION AND SHALL NOT BE REPRODUCED OR COPIED OR USED IN WHOLE OR IN PART AS THE BASIS FOR THE MANUFACTURE OR SALE OF ITEMS WITHOUT WRITTEN PERMISSION FROM DIGITAL EQUIPMENT CORPORATION" COPYRIGHT © 1974, DIGITAL EQUIPMENT CORPORATION

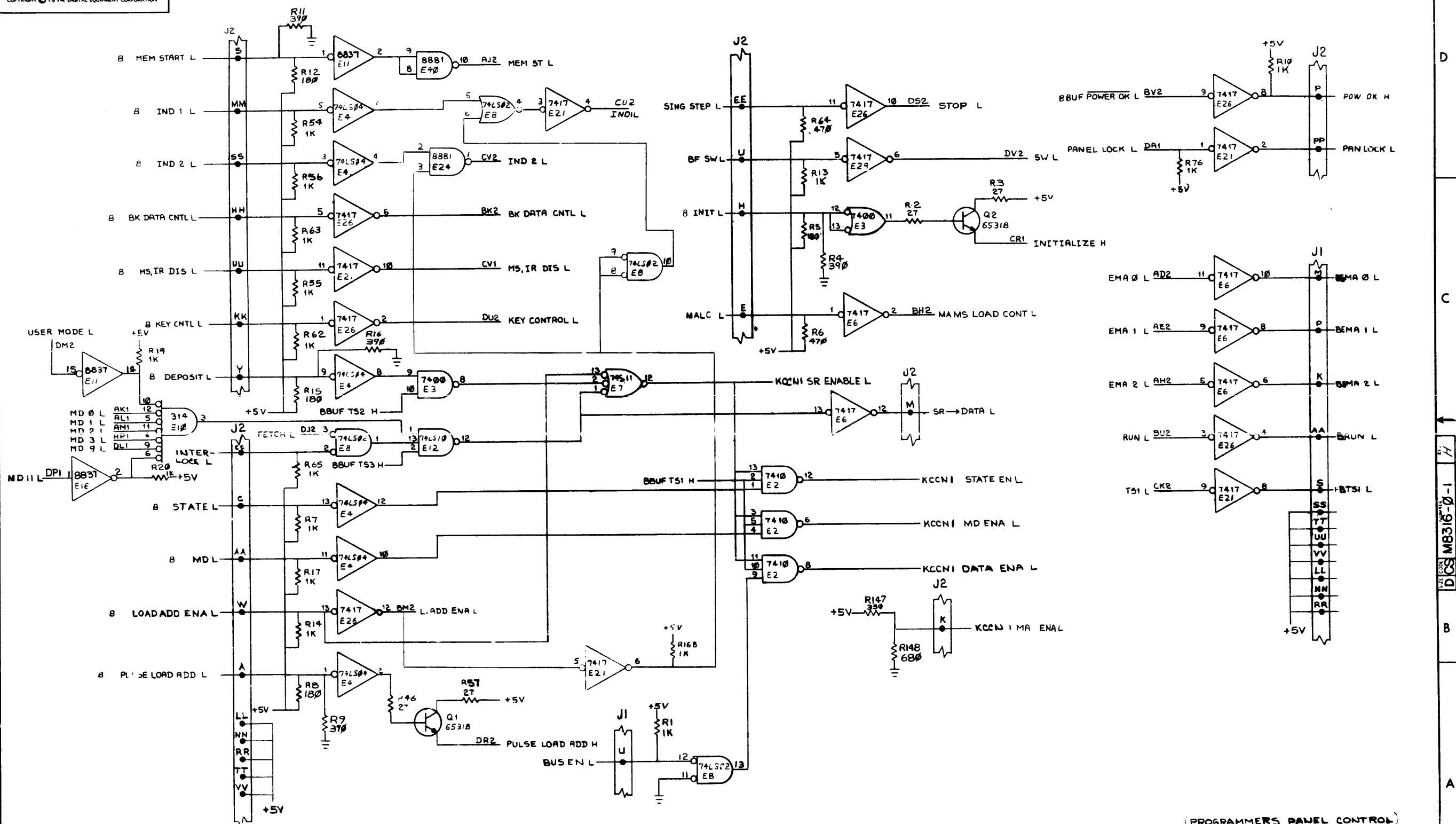

(PROGRAMMER'S PANEL CONTROL)

REVISIONS		
CHK	CHANGE NO	REV

TITLE	OPTION BD #1 (KCCNI)	SIZE CODE	DCS	NUMBER	M8316-0-1	REV.	H
SCALE		SHEET	6	OF	6	DIST.	

"THIS DRAWING AND SPECIFICATIONS HEREIN ARE THE PROPERTY OF DIGITAL EQUIPMENT CORPORATION AND SHALL NOT BE REPRODUCED OR COPIED OR USED IN WHOLE OR IN PART AS THE BASIS FOR THE MANUFACTURE OR SALE OF ITEMS WITHOUT WRITTEN PERMISSION. COPYRIGHT © 1974, DIGITAL EQUIPMENT CORPORATION"

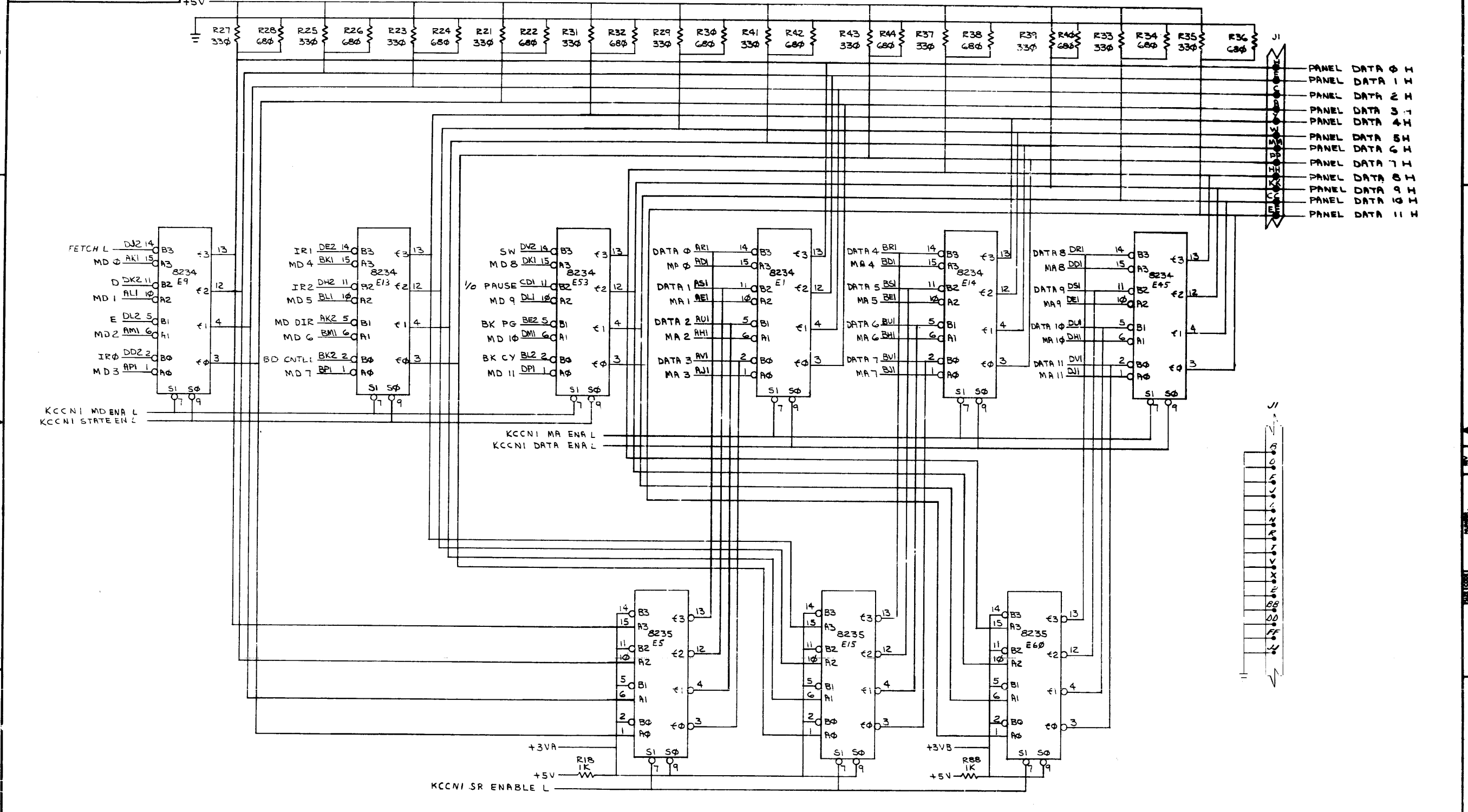

REVISIONS		
CHK	CHANGE NO.	REV.

(PROGRAMMERS PANEL MULTIPLEXERS)

TITLE	OPTION BOARD #1	SIZE CODE	NUMBER	REV.
	(KCGND)	DCSM8316-0-1	H	
SCALE	7-7	SHEET	7 OF 8	DIST.

THIS DRAWING AND SPECIFICATIONS HEREIN ARE THE PROPERTY OF DIGITAL EQUIPMENT CORPORATION AND SHALL NOT BE REPRODUCED OR COPIED OR USED IN WHOLE OR IN PART AS THE BASIS FOR THE MANUFACTURE OR SALE OF ITEMS WITHOUT WRITTEN PERMISSION. COPYRIGHT © 1974 DIGITAL EQUIPMENT CORPORATION

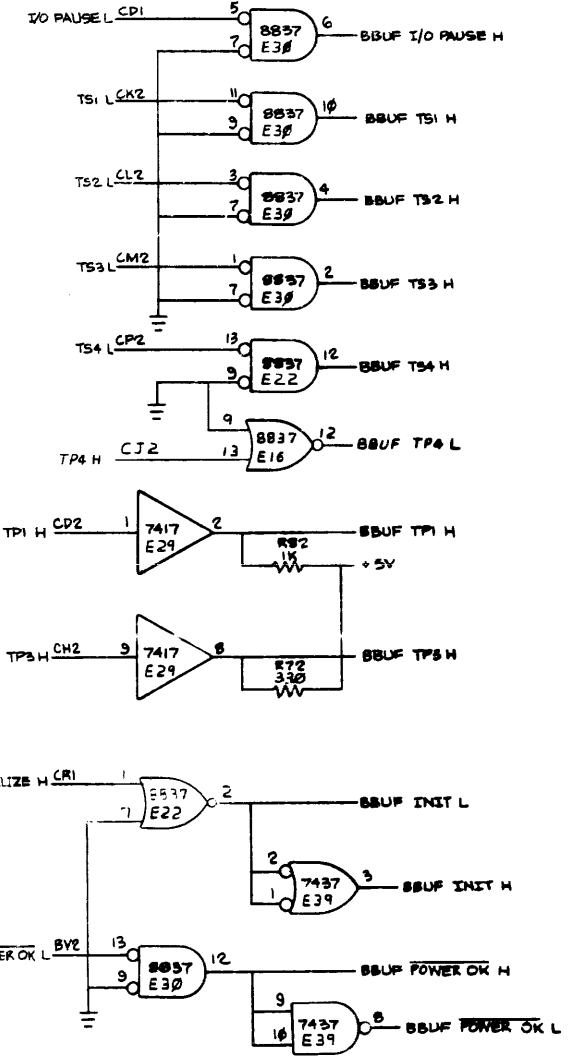
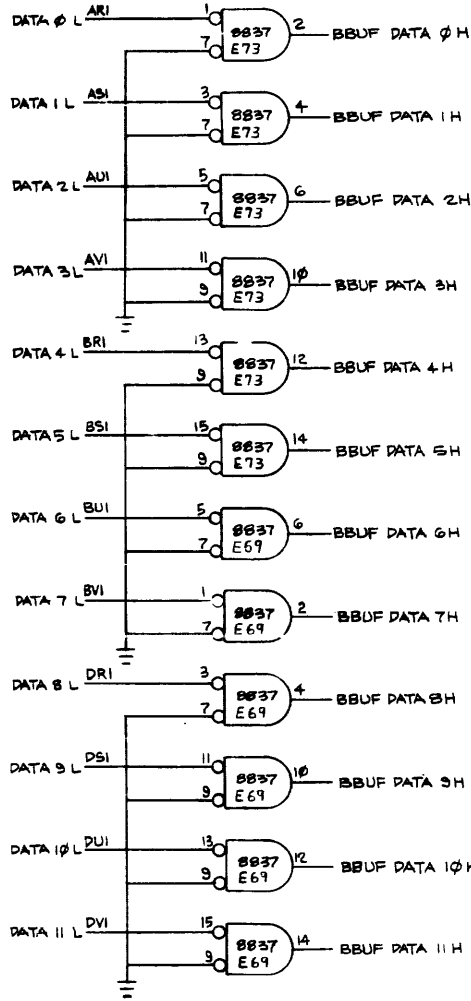
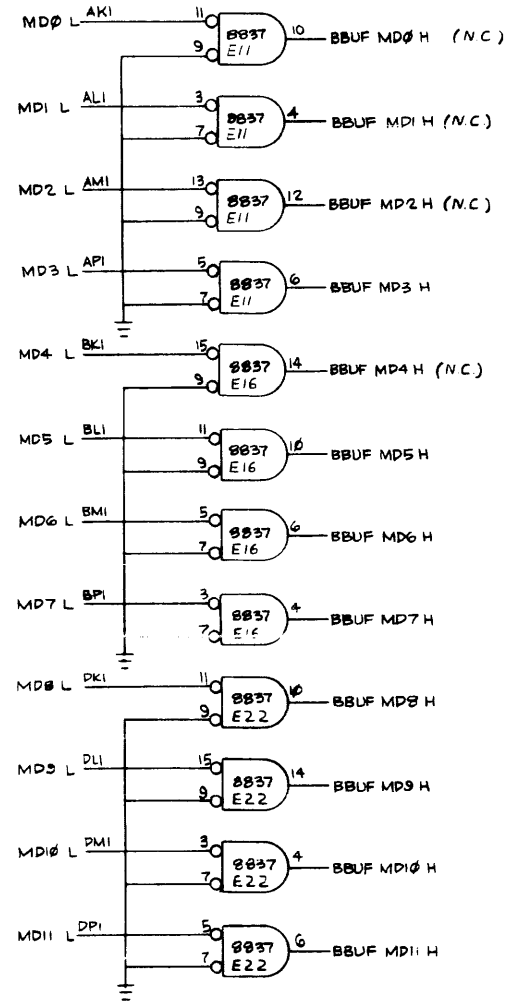

(BUS BUFFERS)

REVISIONS		
CHK	CHANGE NO.	REV.

TITLE	8/A INTERNAL OPTIONS (BUFF)	SIZE CODE	D CS	NUMBER	M8316-0-1	REV.	H
SCALE	1:1	SHEET	2	OF	2	DIST.	

This drawing and specifications, herein, are the property of Digital Equipment Corporation and shall not be reproduced or copied or used in whole or in part as the basis for the manufacture or sale of items without written permission. COPYRIGHT © 1974

DIGITAL EQUIPMENT CORPORATION

REV.	NUMBER	SIZE	CODE	2	1
	M8316-0-8	K	RL		



FIRST USED ON OPTION MODEL	QTY.	DESCRIPTION	PART NO.	ITEM NO.
DKC8 - A				

REVISIONS	REV.	
	CHANGE NO.	
CHK		

DRN.	DATE
<i>W. Losen</i>	11/1/74
CHK'D.	DATE
<i>W. Losen</i>	11/1/74
ENG.	DATE
<i>Sam Taylor</i>	8/1/74
PROJ. ENG.	DATE
<i>Sam Taylor</i>	8/1/74
PROD.	DATE
<i>Don Stone</i>	3/5/74

digital EQUIPMENT CORPORATION
MAYNARD, MASSACHUSETTS

TITLE
ROM PATTERN
SPEC OPTION #1
(KLDK ROM #1)

NEXT HIGHER ASSEMBLY	SIZE	CODE	NUMBER	REV.
B-DD-DKC8-A	K	RL	M8316-0-8	*
SCALE	DIST.			
SHEET 1 OF 2				

This drawing and specifications, herein, are the property of Digital Equipment Corporation and shall not be reproduced or copied or used in whole or in part as the basis for the manufacture or sale of items without written permission. COPYRIGHT © 1974

DIGITAL EQUIPMENT CORPORATION

REV. NUMBER 6-0-918W KRL SIZE CODE 2 1

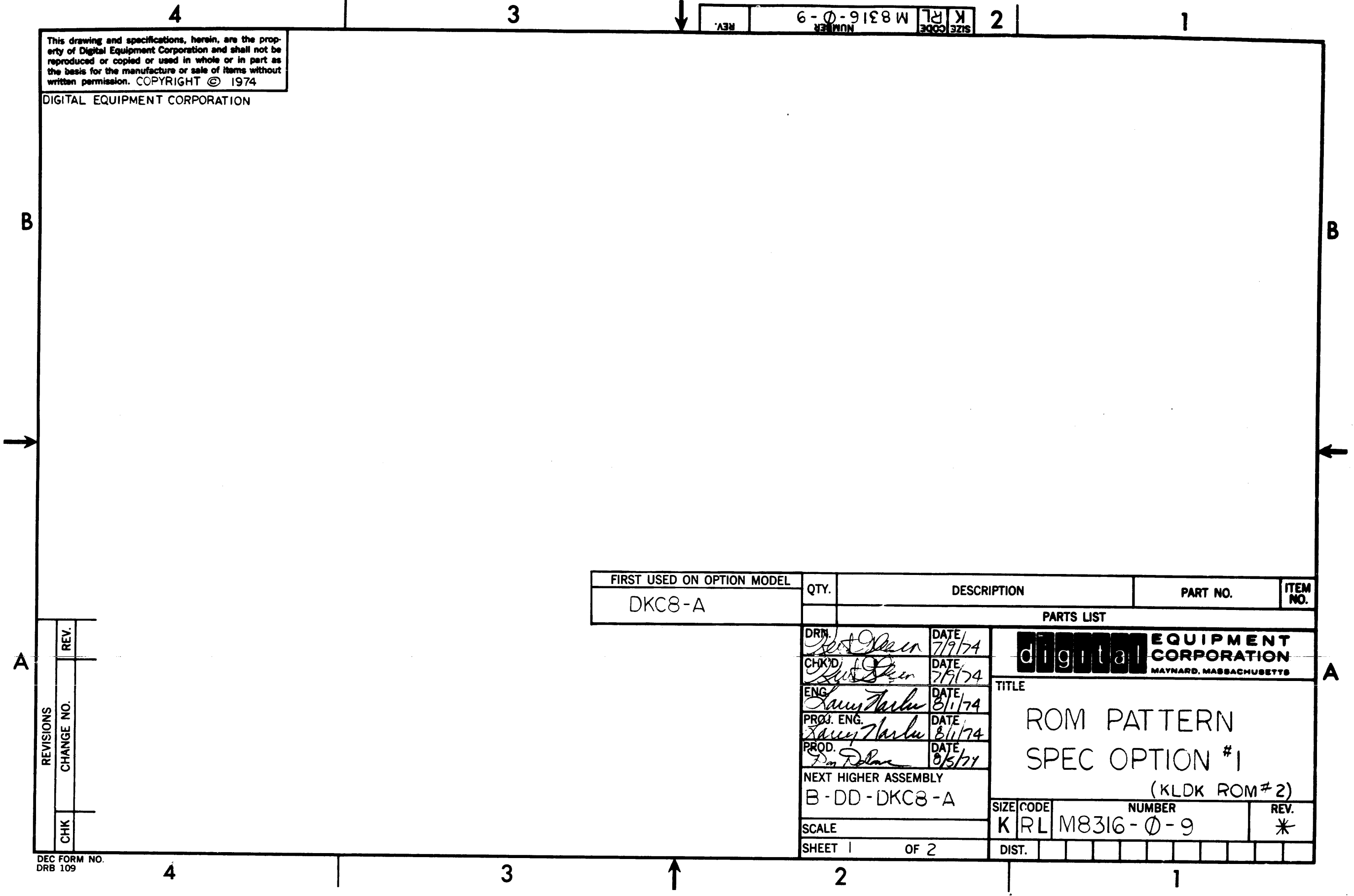

FIRST USED ON OPTION MODEL	QTY.	DESCRIPTION	PART NO.	ITEM NO.
DKC8-A				
PARTS LIST				
DRN. <i>Rest Dain</i>	DATE 7/9/74	<div style="display: flex; align-items: center;"> DIGITAL EQUIPMENT CORPORATION <small>MAYNARD, MASSACHUSETTS</small> </div>		
CHK'D. <i>Rest Dain</i>	DATE 7/9/74			
ENG. <i>Larry Tharlu</i>	DATE 8/1/74			
PROJ. ENG. <i>Larry Tharlu</i>	DATE 8/1/74			
PROD. <i>Don Deane</i>	DATE 8/5/74			
NEXT HIGHER ASSEMBLY		TITLE		
B-DD-DKC8-A		ROM PATTERN SPEC OPTION #1 (KLDK ROM #2)		
SCALE		SIZE CODE	NUMBER	REV.
SHEET 1 OF 2		KRL	M8316-0-9	*
		DIST.		

K RL M8316-Ø-9
DEC PART NUMB: 23-063A1
ORIGINATOR: LARRY NARHT
DATE OF ORIGIN: 01-24-74

DECIMAL LOC	OCTAL LOC	BINARY DATA	OCTAL DATA
0	00	00110000	060
1	01	00110000	060
2	02	00111000	070
3	03	00110000	060
4	04	00110001	061
5	05	00110000	060
6	06	00111001	071
7	07	00110000	060
8	10	00110000	060
9	11	00110000	060
10	12	00110000	060
11	13	00110000	060
12	14	00110000	060
13	15	00110000	060
14	16	00110000	060
15	17	00110000	060
16	20	00110000	060
17	21	00110000	060
18	22	00110000	060
19	23	00110000	060
20	24	00110000	060
21	25	00110000	060
22	26	00110000	060
23	27	00110000	060
24	30	10110000	260
25	31	01110000	160
26	32	10000000	200
27	33	00110000	060
28	34	00100010	042
29	35	00110100	064
30	36	10000010	202
31	37	00110000	060