

# RELAY TYPE W800

# W SERIES

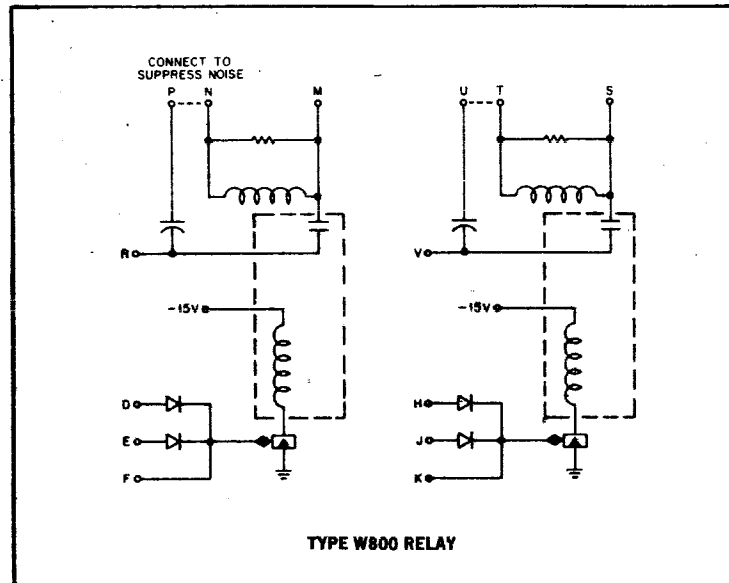

The Type W800 Relay consists of two separate Form A reed relays, each with an optional protecting circuit. When the protecting circuit feature is desired, N and P (T, U) should be connected together, and the external circuit connected to P and R (U, V). To use the relay without the protecting circuit, the external circuit should be connected between M and R (S, V). The protecting circuit consists of a capacitor and a parallel combination of an inductor and a resistor. The protection circuit slows down current and voltage rise time at the time of contact closure and voltage rise time at the time of contact closure or opening in order to minimize undesirable effects on sensitive logic in the vicinity of the relay. The

Type W800 is used to drive heavy loads on computer or logic command. The frequency limit is 100 cps. Maximum relay operating time is 2 msec.

**INPUT:** A Standard Level of  $-3v$  operates the relay. Input load is 1 ma at ground, 0 ma at  $-3v$ , shared by inputs at ground. Pins F and K are for use only with diodes such as R001 and R002. A maximum of 6 in. of wire may be attached to these points.

**OUTPUT:** The relay contacts close when the input requirements are met. Maximum contact ratings are 250v, 500 ma, 10 watts maximum.

**POWER:**  $-15v/124$  ma;  $+10v(A)/0.6$  ma.