

TELETYPE TRANSMITTER

TYPE W707

(DOUBLE HEIGHT)

W
SERIES

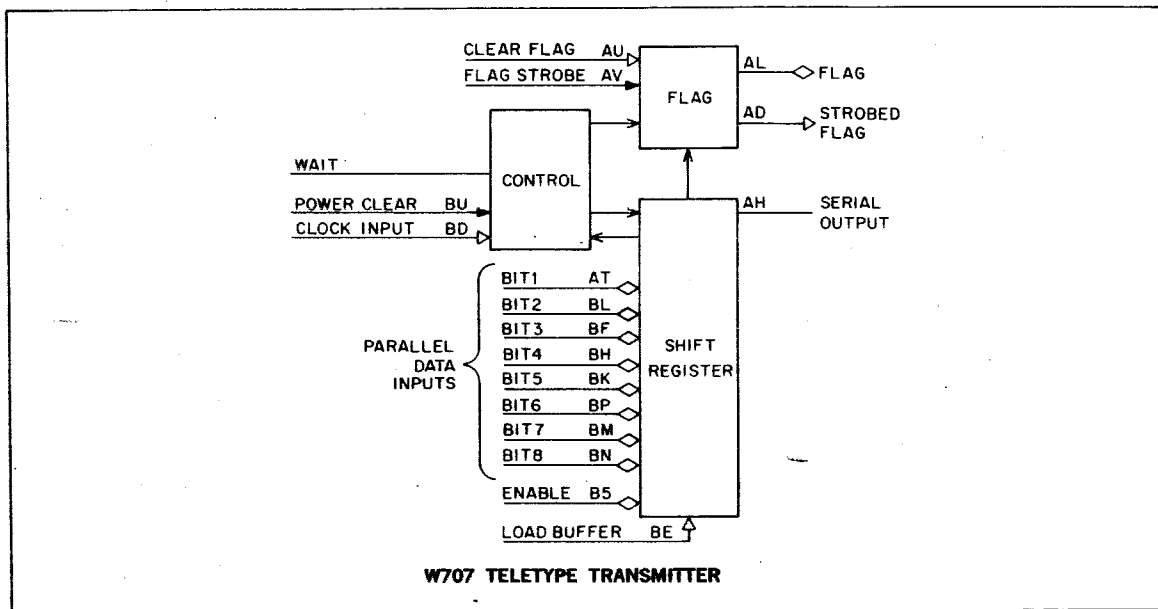

The W707 Teletype Transmitter is an integrated-circuit parallel-to-serial teletype code converter, self contained on a double-height module. This unit includes all of the parallel to serial conversion, buffering, gating, and timing necessary to transfer information in an asynchronous manner between a parallel binary device and a serial teletype line. Either a 5-bit or 8-bit parallel character can be assembled into a 7.0, 7.5, or 8.0 unit serial character or a 10.0, 10.5, or 11.0 unit serial character, respectively, by the W707 through the use of selective jumpers on the module. When the conversion is complete, the necessary one unit negative voltage start signal and a ground level stop signal of 1.0, 1.5, or 2.0 units have been added to the original parallel character and transmitted over the serial line. The serial character is transmitted with the start signal first, followed by bits 1 through 8 in that order, and completed by the stop signal. One-half unit after the stop signal is put on the serial line, the flag is set indicating that the previous character has been transmitted and that a new parallel character can now be loaded into the W707. Transmission of this new character will not occur until the stop time from the previous character is completed. See the timing diagram (Figure 1) for additional information.

The W707 may be connected to devices other than a Teletype. For example, two computer systems can be

connected using a serial line as shown in Figure 2. To obtain additional Teletype applications data write for Applications Note AP-W-1.

INPUTS: Standard Digital levels of -3 volts and ground or 400 nsec pulses as generated by modules types R602 or W103. Input pins are shown on the module diagram above.

CLOCK — 400-nsec positive pulses with a maximum transmitter output frequency of 200 kHz. The clock frequency must be twice the required serial output frequency thus defining one unit of character time as two clock periods. Input loading is 2.8 ma at -3 volts.

LOAD BUFFER — A 400-nsec positive pulse which loads the parallel character into the W707. Typically this pulse is generated after a Flag Output has been sensed so that no incorrect characters will be transmitted. Loading is 2.8 ma at -3 volts.

BITS 1 THROUGH 8 AND ENABLE — Digital standard levels or equivalent with input loading 1.4 ma at -3 volts. When an 8-bit character is to be transmitted, all bit inputs are connected to data lines with bit 1 the least significant bit. For 5-bit characters, bits 1 through 5 are connected to data lines with bit 1 the least significant bit. Bit 6 is now used as the

W707 — \$150.00

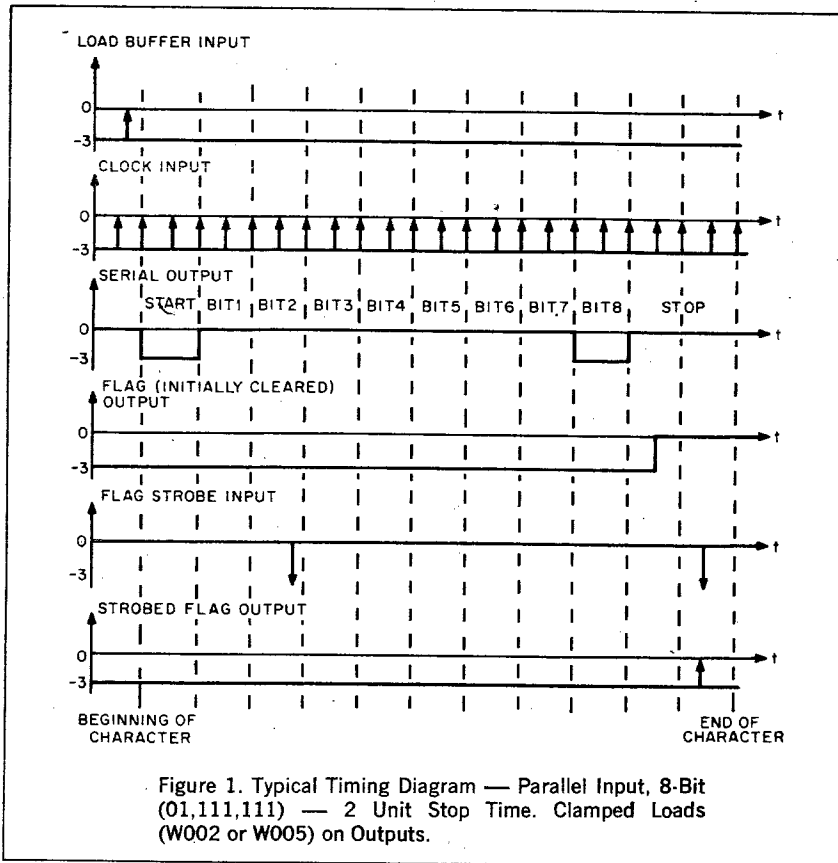

Enable input, and bits 7, 8, and Enable are tied together and either returned to -15 volts through a $2.7K$ resistor or individually connected to W002 clamped loads. If the Enable input (Enable or bit 6 depending on character length) is at -3 volts during a Load Buffer Pulse, the parallel character information is loaded into the W707, but no serial transmission will occur. The Enable input must be at ground during a Load Buffer Pulse for serial information transmission. Ground levels on bit inputs represent a logical 1 or a Teletype "mark," and generate a ground output on the serial line at the corresponding bit times.

CLEAR FLAG: A ground level or DEC standard 400 nsec positive pulse will clear the flag. If a level is used, it must be returned to -3 volts before the flag can be set. Loading is 1.4 ma at -3 volts. Typically the flag is sensed through one of the flag outputs and then cleared.

FLAG STROBE: DEC standard 400 nsec negative pulse or a -3 volt level. Loading is 1.4 ma at -3 volts. This input is NANDed with the flag and provides a ground level Strobed Flag Output signal when the flag is set.

POWER CLEAR: Same input signals and loading as for Flag Strobe. Initialization of module elements by a Power Clear signal is not necessary if the first serial character transmitted after power turn-on need

not be correct. When not used, Power Clear can be left disconnected.

WAIT: This input is available for use with the W708 in half duplex operation. Internal logic levels of $+3.6$ and ground appear at this input. It must not be connected to any signal but the WAIT output of the W708. If not used, this input must be left disconnected.

OUTPUTS: All outputs are capable of supplying 20 ma at ground. The external load may be connected to any voltage between ground and -20 volts. Clamped loads such as W002 and W005 can also be used.

SERIAL OUTPUT: Provides the teletype code serial output during character transmission. A logical 1 output is a ground level. If inductive loads are driven by this output, diode protection must be provided by connecting the cathode of a diode to the output and the anode of this diode to the negative supply used at the output.

FLAG OUTPUT: Ground level output when the flag is set.

STROBED FLAG OUTPUT: Ground level output when Flag Strobe is at -3 volts and the flag is set.

INVERTER: Pins BJ and AP are the input respectively of an inverter that can be used for any needed buffering. Input load is 1.8 ma at -3 volts.

JUMPERS: Jumper positions are indicated on the top view physical sketch shown in Figure 3. The W707 is shipped with all jumpers in position.

POWER: $-15(B)/3$ ma; $+3.6$ volts/400 ma. This power is available from a W705 or any commercial supply that has an output regulation of $\pm 5\%$.

