

POSITIVE OUTPUT CONVERTER

TYPE W601

W
SERIES

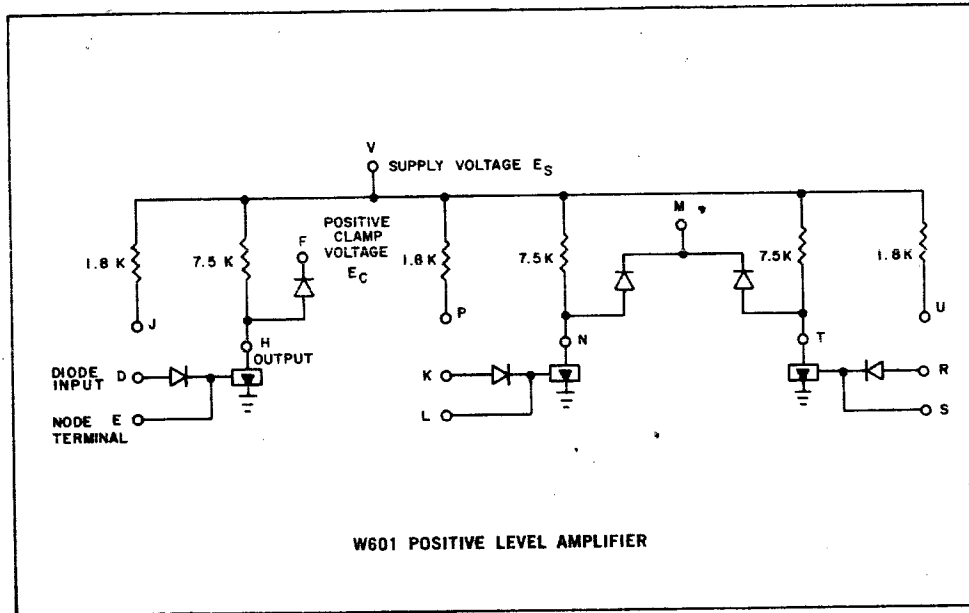

The W601 contains three amplifiers for converting DEC standard levels to outputs of ground and an externally supplied clamp voltage level, E_c . This external clamp voltage is applied to terminal F (M) and must be between +1 and +20v. Additional inputs can be added by tying diode networks, such as the R001 or the R002, to the node terminal. These inputs form a NOR gate for ground levels and a NAND gate for negative input levels. That is, if any input diode is at ground, the output will be at ground, and if all inputs are at $-3v$, the output will be at E_c . A positive supply voltage E_s greater than E_c should be tied to terminal V. If E_c is less than +10v, the +10v supply on terminal A may be used at the supply voltage on terminal V.

INPUT: Standard levels. The input load for each amplifier is 2 ma shared by all grounded inputs including those attached through diode networks to the node terminal.

EXTERNAL VOLTAGE: Terminal F (M) — The external clamp voltage E_c applied to terminal F (M) can be between +1 and +20v. The load is 500 ohms to $+E_s$ (if the 1800-ohm resistors are used)

or 2500 ohms to $+E_s$ (if the 1800-ohm resistors are not used). Terminal V — The supply voltage E_s on terminal V should be greater than E_c but not greater than +20v. The load is 500 ohms (if the 1800-ohm resistors are used) or 2500 ohms (if the 1800-ohm resistors are not used) to ground.

OUTPUT: Output levels are ground and a positive external clamp voltage, E_c . Output drive depends on the two external voltages. They are given in the table below.

EXTERNAL DRIVING CAPABILITIES OF W601

	OUTPUT CURRENT	
	AT GROUND	AT CLAMP VOLTAGE
Without additional resistor	$(20 - \frac{E_s}{7.5})\text{ma}$	$(\frac{E_s - E_c}{7.5})\text{ma}$
With additional resistor, i.e. H (N, T) connected to J, P, or U.	$(20 - \frac{E_s}{1.5})\text{ma}$	$(\frac{E_s - E_c}{1.5})\text{ma}$

POWER: +10 v(A)/3 ma; -15 v(B)/6 ma.

W601 — \$13.00