

SOLENOID DRIVERS

TYPES W040, W043

W

SERIES

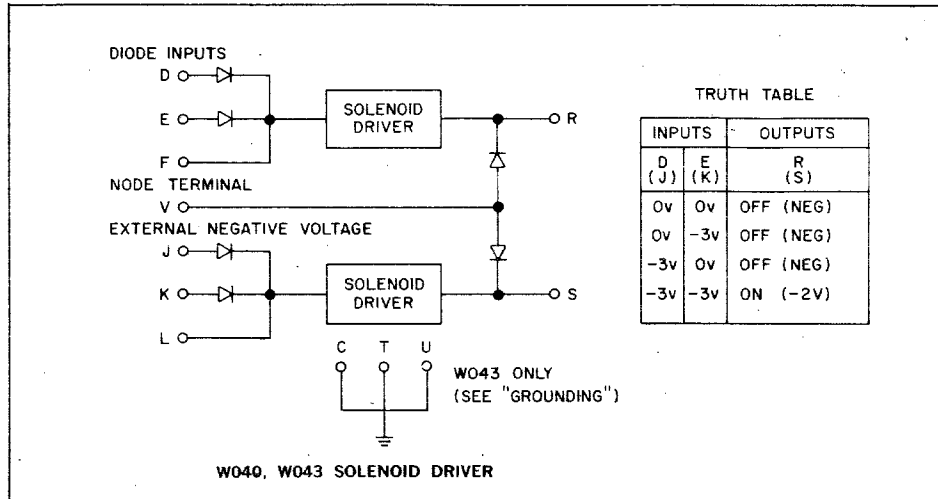

These high current drivers can drive relays, solenoids, stepping motor windings, or other similar loads. The output levels are -2 volts and a more negative voltage determined by an external power supply. One terminal of the load device should be connected to the external power source, the other to the driver output. There are two drivers per module and both modules use the same pin connections.

Pin V of the driver module must be connected to the external supply so that the drivers will be protected from the back voltage generated by inductive loads. If the wire to the power supply is more than 3 feet long it may have to be by-passed at the module with an electrolytic capacitor to reduce the short overshoot caused by the inductance of the wire. If pin V is connected to the supply through a resistor, the recovery time of inductive loads can be decreased at a sacrifice in maximum drive voltage capability. Maximum rated supply voltage (see below) less actual supply voltage should be divided by load current to find the maximum safe resistance. When both circuits on a module are used, the load current for the above calculation is the sum of the currents.

INPUTS: Standard DEC levels or equivalent. The maximum input load is 3 ma. per driver, shared by all grounded inputs. Additional diode inputs may be added by connecting diode networks such as R001 or R002 to the node terminal.

OUTPUTS: The table below shows maximum ratings for individual circuits. No more than two circuits should be paralleled to drive loads beyond the current capabilities of single circuits. For larger loads use the W042. When both circuits on a W043 are used with a duty cycle exceeding 35%, use the

current derating curve shown below.

GROUNDING: The W043 has three ground terminals C, T, U, which should be wired together externally to limit current through each connector pin to safe levels. (High current loads should be grounded at the W040 or W043 modules to avoid noise due to high pulse currents in ground conductors.)

MODULE	MAXIMUM VOLTAGE	MAXIMUM CURRENT	TYPICAL DELAY
W040	-70 V	0.6 amp.	$5 \mu\text{sec}$
W043	-35 V	2.0 amp.	$10 \mu\text{sec}$

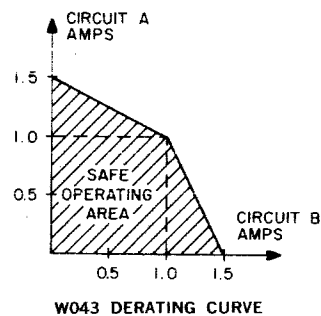

POWER: W040: $+10\text{v}$ (A)/ 0 MA, -15v (B)/24 MA. The external voltage supply must supply the output current of the two drivers (1.2 amp max.)

W043: $+10\text{v}$ (a)/0.25 MA, -15v (B) /6 MA: The external voltage supply must supply the output current (2.0 amp max.)

W040 — \$36.00

W043 — \$35.00