

PULSE AMPLIFIERS

TYPES R602, R603

R

SERIES

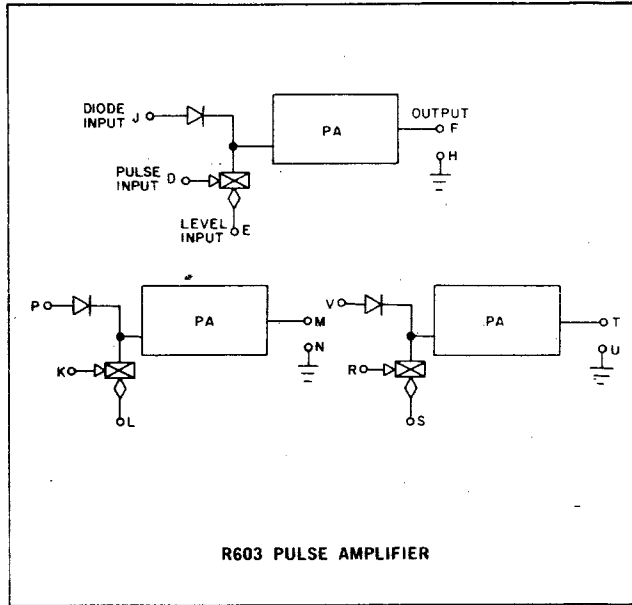
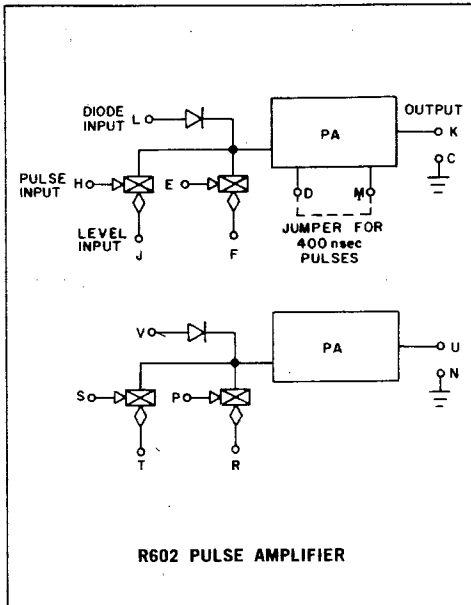

The R602 and R603 contain pulse amplifiers for power amplification and for standardizing pulses in amplitude and width. Each amplifier produces standard 100-nsec pulses and one section of the R602 can also produce 400 nsec pulses. DCD gates and a single diode input permit inputs from many sources to be mixed. Input pulses can occur at any frequency up to 2 mc for 100 nsec pulses, and up to 1 mc for 400 nsec pulses. Delay through the pulse amplifier is approximately 50 nsec.

INPUTS: Level and Pulse — Same as R601. **Diode** — Standard 100-nsec pulses (–3v to ground) or

positive-going level changes (–3v to ground) with a rise time of 60 nsec max. The input level must be

returned to –3v for at least 400 nsec before another input may occur at either the diode or the DCD gate input. The diode input represents a 1-ma load at ground.

OUTPUTS: Outputs are standard 100 nsec pulse, –3v to ground (except pin K of R602, which may be changed to 400 nsec pulses by connecting pin D to pin M). Each output can drive up to 70 ma load at ground. The internal load is 3 ma. Pulse amplifier outputs may be paralleled to obtain a logical OR. Pulse lines and grounds should be kept as short as possible.

POWER: R602: + 10 v(A)/2.2 ma; – 15 v(B)/45 ma.
R603: + 10 v(A)/3.3 ma; – 15 v(B)/57 ma.

R602 — \$22.00
R603 — \$28.00
