

# AND/NOR GATE TYPE R141

# R SERIES

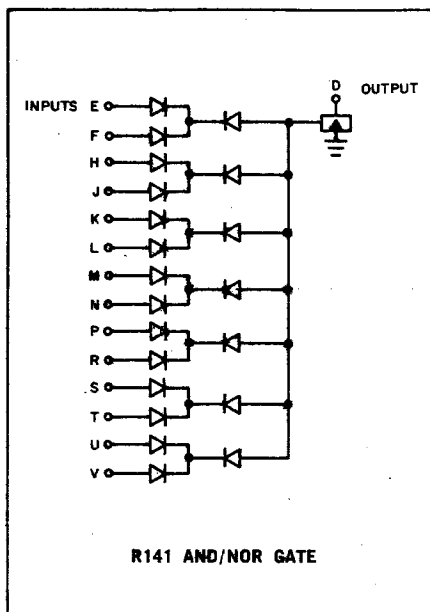

The R141 AND/NOR Gate performs two levels of gating. The module contains a multiple-input diode gate with a transistor inverter for signal amplification. For negative input signals the R141 is seven 2-input AND gates which are NORed together. For ground inputs, it is seven 2-input OR gates NANDed together. This module is frequently used to mix multiple inputs to a pulse amplifier, or to compare the contents of two flip-flop registers.

The back-to-back diode circuits are possible because of an internal bias resistor connected to the input of each second stage diode. The bias holds the input of the second stage at  $-3v$  unless one of the first stage inputs is grounded. Propagation delay for output rise is similar to R111 delay. For output fall, delay is typically 100 nsec longer than R111 delay

under similar loading conditions, assuring sufficient pulse stretching to allow 70 nsec inputs. Output is typically too wide, however, to allow 2 mc rates. Maximum rate depends upon R141 loading, and may be as low as 1 mc.

**INPUT:** Standard 100-nsec pulses, standard levels of  $-3v$  and ground, or 70-nsec negative pulses such as those generated by the W607 Pulse Amplifier. Input load is 1 ma per input pair shared by the grounded inputs. When any pair of inputs is not being used, at least one of the two must be grounded.

**OUTPUT:** Standard levels of  $-3v$  and ground. The output can drive 20 ma of external load at ground. It has no internal load.

**POWER:**  $+10 v(A)/0.5 ma$ ,  $-15 v(B)/19 ma$ .