

BINARY-TO-OCTAL DECODER TYPE R151

**R
SERIES**

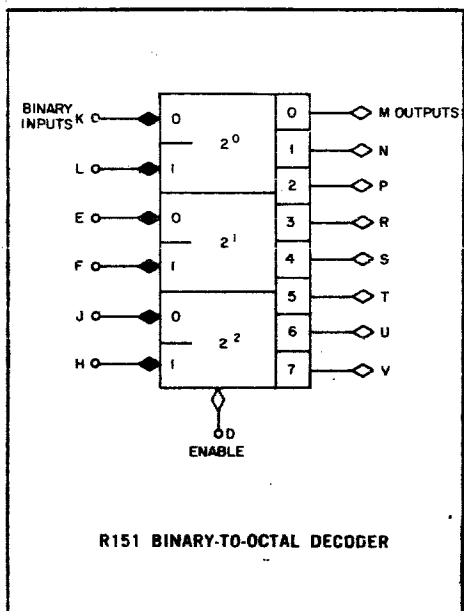

TRUTH TABLE

| INPUTS | | | | | | | OUTPUTS | | | | | | | |
|--------|-----|-----|-----|-----|-----|-----|---------|-----|-----|-----|-----|-----|-----|-----|
| J | H | E | F | K | L | D | M | N | P | R | S | T | U | V |
| -3v | 0v | -3v | 0v | -3v | 0v | 0v | 0v | -3v | -3v | -3v | -3v | -3v | -3v | -3v |
| -3v | 0v | -3v | 0v | 0v | -3v | 0v | -3v | 0v | -3v | -3v | -3v | -3v | -3v | -3v |
| -3v | 0v | 0v | -3v | -3v | 0v | 0v | -3v | -3v | 0v | -3v | -3v | -3v | -3v | -3v |
| -3v | 0v | 0v | -3v | 0v | -3v | 0v | -3v | -3v | -3v | 0v | -3v | -3v | -3v | -3v |
| 0v | -3v | -3v | 0v | -3v | 0v | 0v | -3v | -3v | -3v | -3v | 0v | -3v | -3v | -3v |
| 0v | -3v | -3v | 0v | 0v | -3v | 0v | -3v | -3v | -3v | -3v | -3v | 0v | -3v | -3v |
| 0v | -3v | 0v | -3v | -3v | 0v | 0v | -3v | -3v | -3v | -3v | -3v | -3v | 0v | -3v |
| 0v | -3v | 0v | -3v | 0v | -3v | 0v | -3v | -3v | -3v | -3v | -3v | -3v | -3v | 0v |
| | | | | | | -3v | -3v | -3v | -3v | -3v | -3v | -3v | -3v | -3v |
| -3v | -3v | -3v | -3v | 0v | -3v | 0v | -3v | 0v | -3v | 0v | -3v | 0v | -3v | 0v |
| -3v | -3v | -3v | -3v | -3v | 0v | 0v | 0v | -3v | 0v | -3v | 0v | -3v | 0v | -3v |
| -3v | -3v | 0v | -3v | -3v | -3v | 0v | -3v | -3v | 0v | 0v | -3v | -3v | 0v | 0v |
| -3v | -3v | -3v | 0v | -3v | -3v | 0v | 0v | 0v | -3v | -3v | 0v | 0v | -3v | -3v |
| 0v | -3v | -3v | -3v | -3v | -3v | 0v | -3v | -3v | -3v | -3v | 0v | 0v | 0v | 0v |
| -3v | 0v | -3v | -3v | -3v | -3v | 0v | 0v | 0v | 0v | 0v | -3v | -3v | -3v | -3v |

The R151 decodes binary information from three flip-flops into octal form. When the enable input is at ground, the selected output line is at ground and the other seven outputs are at $-3v$. When the enable input is at $-3v$, all outputs are at $-3v$. The internal gates are similar to those in the R111. The enable input is the common emitter connection of the output inverters. Typical total transition times are 75 nsec for output rise and 60 nsec for output fall.

INPUT: Binary — Standard levels of $-3v$ and ground, 100 nsec minimum duration. Input load is

2.3 ma per grounded input when the inputs are binary, as in the first 8 lines of the truth table. The input current is 4 ma at ground when only one input is grounded, as in the last 6 lines of the truth table. **Enable** — Standard levels of $-3v$ and ground, 100 nsec minimum duration. Input load at ground is 3 ma plus the current required by the load on the selected output when the inputs are binary, as in the

first 8 lines of the truth table. For other inputs, the load is 3 ma per selected output plus the loads on those selected outputs. The maximum input current is 10 ma when driven from an inverter collector. No more than one inverter can be placed in series with this pin and ground. If any external circuit brings an R151 output to ground, any gate being used to enable pin D must not drive anything else.

OUTPUT: Standard levels. Each octal output has a permanently attached 2-ma clamped load resistor. Each output can drive 7 ma of load at ground. If the enable input is permanently grounded, each output can drive 18 ma of load at ground. The length of the wire used to ground the enable input (pin D) should be kept as short as possible. Note: Simultaneous switching of R151 outputs is not assured. If adjacent R151 outputs are ORed together for example, the gate output may contain spikes.

POWER: $+10 v(A)/0.9 ma$, $-15 v/32 ma$.

R151 — \$33.00