

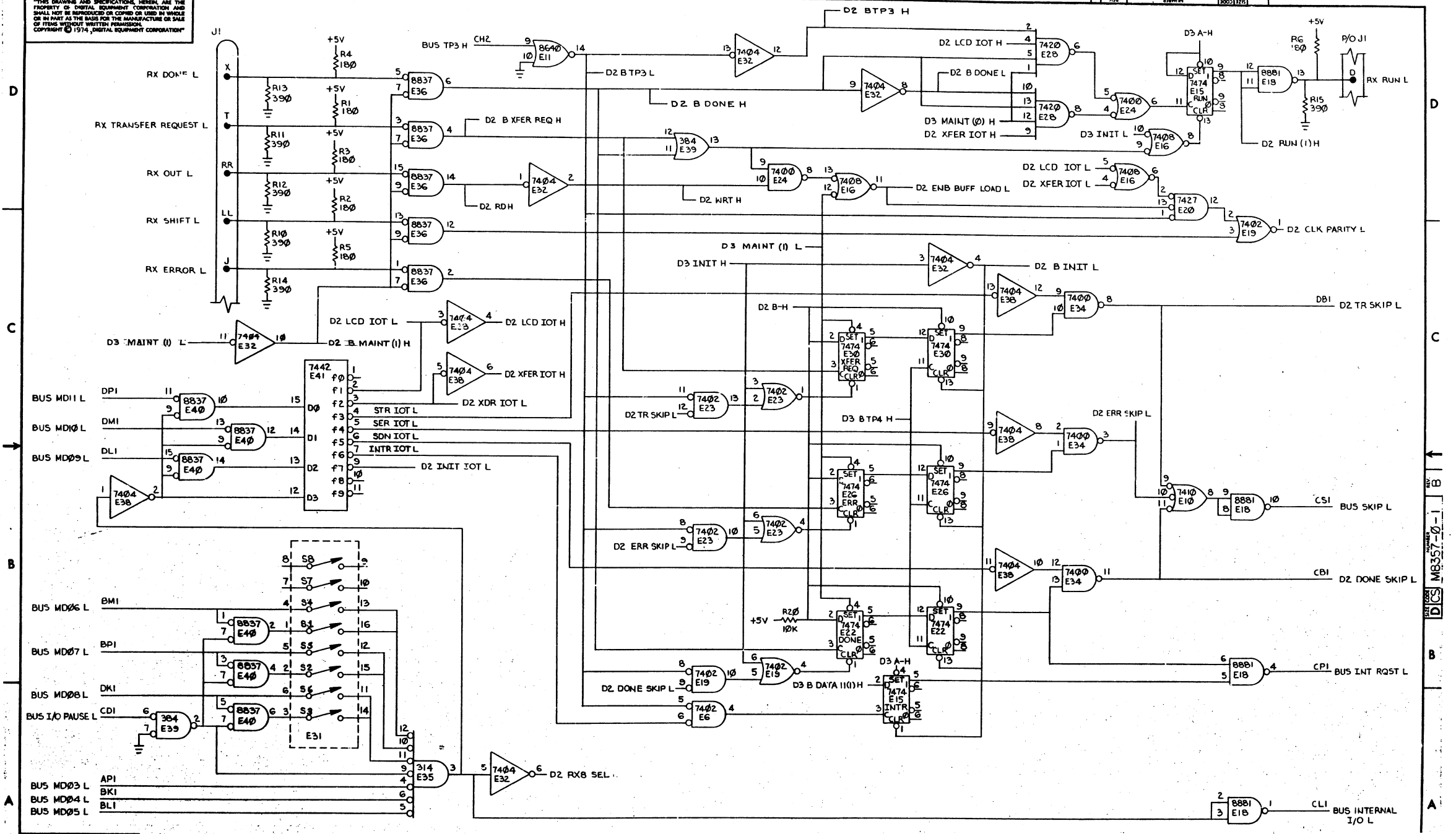

THIS DRAWING AND SPECIFICATIONS, HEREIN, ARE THE PROPERTY OF DIGITAL EQUIPMENT CORPORATION AND SHALL NOT BE REPRODUCED OR COPIED IN WHOLE OR IN PART AS THE BASIS FOR THE MANUFACTURE OR SALE OF ITEMS WITHOUT WRITTEN PERMISSION. COPYRIGHT © 1974, DIGITAL EQUIPMENT CORPORATION



REVISIONS		
CHK	CHANGE NO.	REV.

(DEVICE SELECT, IOT DECODE & RXOI CONTROL LOGIC)

TITLE	RX8-E (D2)	SIZE CODE	D CS	NUMBER	M8357-0-1	REV.	B
SCALE	1:1	SHEET	2 OF 3	DIST.			

REV. B  
M8357-0-1

