

digital

TUI6
Engineering Drawings
Digital Equipment Corporation

The material herein is for information purposes only and is subject to change without notice. Digital Equipment Corporation assumes no responsibility for any errors which may appear herein.

These drawings and specifications herein are the property of Digital Equipment Corporation and shall not be reproduced or copied or used in whole or in part as the basis for the manufacture or sale of items without written permission.
Copyright © 1975, Digital Equipment Corporation

DRAWING DIRECTORY

"THIS DRAWING AND SPECIFICATIONS, HEREIN, ARE THE PROPERTY OF DIGITAL EQUIPMENT CORPORATION AND SHALL NOT BE REPRODUCED OR COPIED OR USED IN WHOLE OR IN PART AS THE BASIS FOR THE MANUFACTURE OR SALE OF ITEMS WITHOUT WRITTEN PERMISSION. COPYRIGHT © 1974, DIGITAL EQUIPMENT CORPORATION"

CUSTOMER PRINT SET INDEX

THIS IS PRINT SET

DRAWING DIRECTORY
LOGIC AND WRITE BOARD
CLOCK AND TEST LOGIC
SLAVE TEST FUNCTION GEN.
POWER BOARD
READ CHAN. AMP/ANA. & DIA
D.S. POWER SUPPLY
GENERAL PURPOSE CARD (E & F)
GENERAL PURPOSE CARD (A & B)
GENERAL PURPOSE CARD (E & F)
DATA DRIVER
DATA DRIVER
GENERAL PURPOSE CARD (A & B)
CONTROL BOX
WIRED ASSY

WIRE LIST
MODULE UTILIZATION
MASS BUS TRANSCIEVER
TAPE TRANSPORT ASSY
MAGTAPE DRIVE

B-DD-TU16- β
D-CS-M891 β - β -1
D-CS-M8911- β -1
D-CS-M8912- β -1
D-CS-H6 β 6- β -1
D-CS-G β 56- β -1
D-CS-5410451-0-1
D-CS-M9 β β 1-YA-1
D-CS-M9 β β 1-YB-1
D-CS-M9 β β 1-YC-1
D-CS-M8913- β -1
D-CS-M8913-YA-1
D-CS-M9 β β 1- β -1
D-CS-7009637-0-1
E-AD-7009635-0-0

K-WL-TU16- β -WL
D-MU-TU16- β -MU
D-BS-TU16- β -2
E-AD-7009634-0-0
D-UA-TU16-0-0

SHEET 1 ONLY

UNIT VARIATIONS		PRINT SET			
VAR	TITLE	1			
TU16-EE	SLAVE 115V 60 HZ	X			
TU16-EF	SLAVE 230V 60 HZ	X			
TU16-EH	SLAVE 115V 50HZ	X			
TU16-EJ	SLAVE 230V 50 HZ	X			
TU16-EA	TU16-EE & TM02-FA				
TU16-EB	TU16-EF & TM02-FB				
TU16-EC	TU16-EH & TM02-FA				
TU16-ED	TU16-EJ & TM02-FB				
TU16-EK	TU16-EE & TM02-FC				
TU16-EL	TU16-EF & TM02-FD				
TU16-EM	TU16-EH & TM02-FC				
TU16-EN	TU16-EJ & TM02-FD				
TU16-AE	SLAVE 115V 60 HZ				
TU16-AF	SLAVE 230V 60 HZ				
TU16-AH	SLAVE 115V 50 HZ				
TU16-AJ	SLAVE 230V 50 HZ				
TU16-AA	TU16-AE & TM02-FA				
TU16-AB	TU16-AF & TM02-FB				
TU16-AC	TU16-AH & TM02-FA				
TU16-AD	TU16-AJ & TM02-FB				

DEC 16-13251-1062-1A-R972

REVISIONS		REV	CHG. NO.
		A	TU16-3
		B	TU16-5
		C	TU16-6
		D	TU16-9
		E	TU16-10
		F	TU16-11
		H	TU16-12
		J	TU16-13
		K	TU16-14
		L	TU16-15
		M	TU16-16
		N	TU16-19
		P	7006743-2
		R	TU16-20
		S	TU16-21
		T	TU16-22
		U	TU16-23
		V	TU16-25
		W	TU16-28
		Y	TU16-29
		Z	TU16-30

USED ON OPTION/MODEL	DATE	TITLE
	8/27/74	MAGNETIC TAPE UNIT
PROJ ENG.	DATE	
	8/29/74	
PROD.	DATE	SIZE CODE
		B DD
FIELD SERV.	DATE	NUMBER
	7/3/74	TU16- β
		REV
		1 Z

THIS DRAWING AND SPECIFICATIONS HEREIN ARE THE PROPERTY OF DIGITAL EQUIPMENT CORPORATION AND SHALL NOT BE REPRODUCED OR COPIED OR USED IN WHOLE OR IN PART AS THE BASIS FOR THE MANUFACTURE OR SALE OF ITEMS WITHOUT WRITTEN PERMISSION. COPYRIGHT © 1973, DIGITAL EQUIPMENT CORPORATION.

NOTES:
 1. FOR PART NO. 1910645-01 - QTY 2 754525 PER CARRIER.

QTY	REF DESIGNATION	DESCRIPTION	PART NO	ITEM NO
REF		X-Y COORDINATE HOLE LOCATION	K-C0-M8910-0-4	1
REF		ASSY/DRILLING HOLE LAYOUT	D-AH-M8910-0-5	2
REF		MODULE ECO HISTORY	B-MH-M8910-0-6	3
1		ETCHED CIRCUIT BOARD	501047D	4
1	C96	CAP 220PF 100V 5% DM	1000021	5
1	C122	CAP 330PF 100V 5% DM	1000023	6
1	C121	CAP 1000PF 250V 20% DISC	1000043	7
6	C99, C105, C106, C123, C119, C118	CAP 3.9UF 10% 10V TANT	1000064	8
3	C97, C95, C104	CAP 39UF 10% 10V TANT	1000076	9
87	C1-C61, C63-C68, C63, C70, C72, C74, C75, C77, C78, C80, C81, C83, C84, C86, C87, C89, C91, C94, C95, C101, C102, C108, C109, C120	CAP .01UF, 100V DISC	1001610-01	10
1	C103	CAP 15UF 20V 10% TANT	1004812	11
2	C100, C124	CAP .05UF, 25V, 20% DISC	1001774	12
1	C62	CAP 22UF, 35V, 20% TANT	1002433	13
1	C117	CAP 330UF 20% TANT	1009808	14
7	C98, C110 THRU C115	CAP 6.8UF 10% 35V TANT	1005306	15
11	C64, C69, C71, C73, C76, C79, C82, C85, C88, 101, 116	CAP 5000PF 100V 20% DISC	1001765	16
1	C90	CAP 470.PF 100V 5% DM	1000024	17
1	C92	CAP 100PF 100V 5% DM	1000016	18
1		HEAT SINK	1210001	19
7	D7, D9, D2, D4, D13, D14, D15	DIODE D664	1100114	20
1	D12	DIODE 1N748A 3.9V	1100122	21
1	D3	DIODE D670-1	1102162	22
5	D5, D6, D8, D10, D11	DIODE 1N746A 3.3V	1104860	23
2	J1, J2	CONN 40 PIN RT. ANGLE HDR	1209941	24
1	J3	CONN 28 PIN	1210067-2	25
1	R4	RES 220 OHM 1/2W 5%	1300274	26
4	R66, R77, R101 + R112	RES 220 OHM 1/4W 5%	1300271	27
1	R78	RES 330 OHM 1/4W 5%	1300295	28
10	R3, R5, R9, R15, R21, R27, R41, R42, R44 + R46	RES 470 OHM 1/2W 5%	1300315	29
34	R48-R50, R54-R61, R70, R71, R74-R76, R79, R89, R90, R93-R95, R102, R104, R106, R107, R111, R113, R117	RES 1K 1/4W 5%	1300365	30
2	R86, R108	RES 1.8K 1/4W 5%	1300898	31
2	R64, R67	RES 3.9K 1/4W 5%	1300444	32
2	R52, R53	RES 4.7K 1/4W 5%	1300447	33
2	R63, R68	RES 10K 1/4W 5%	1300479	34
2	R69, R92	RES 12K 1/4W 5%	1300488	35
3	R73, R82, R84	RES 1.2K 1/4W 5%	1301320	36
2	R83, R85	RES 6.8K 1/4W 5%	1301423	37
1	R51,	RES 680 OHM 1/4 5%	1301424	38
1	R72	RES 47K 1/4W 5%	1302177	39
18	R7, R8, R11 THRU R14, R16, R18, R19, R20, R22, R24, R25, R26, R28, R30, R31, R32	RES 39 OHM 1/4W 5%	1302377	40
2	R87, R105	RES 27K 1/4W 5%	1305346	41
4	R62, R103, R88, R91	RES 100 OHM 1/4W 5%	1300229	42
1	R2	RES 750 OHM 1/2W 5%	1300354	43
1	R80	RES 20K 1/4W 5%	1302391	44
1	R110	RES 47 OHM 1/2W 5%	1301695	45

QTY	REF DESIGNATION	DESCRIPTION	PART NO	ITEM NO
2	Q1, Q2	TRANSISTOR 3639B	1502762	46
3	Q4, Q5, Q6	TRANSISTOR 6531B	1509338	47
1	Q3	TRANSISTOR 3762	1509649	48
18	L1 THRU L18	INDUCTOR, FIXED, 10UH, 10%	1609477	49
7	E11, E51, E53, E59, E60, E65, E47	I.C. 7474	1905547	50
4	E28, E41, E58, E66	I.C. 7400	1905575	51
1	E55	I.C. 7410	1905576	52
1	E64	I.C. 7420	1905577	53
1	E44	I.C. 75432	1910645-00	54
5	E2, E6, E20, E21, E25	I.C. 7473	1905587	55
1	E61	I.C. 7481	1905590	56
2	E43, E57	I.C. 7402	1909004	57
1	E29	I.C. 384	1909486	58
3	E31, E35, E40	I.C. 7404	1909686	59
1	E59	I.C. 8242	1909712	60
2	E37, E58	I.C. 7405	1909930	61
3	E5, E19, E54	I.C. 8266	1909934	62
3	E1, E10, E24	I.C. 7486	1910011	63
1	E12	I.C. 74164	1910041	64
3	E46, E49, E32	I.C. 7408	1910155	65
3	E42, E45, E52	I.C. 74123	1910436	66
11	(E3, E4, E7, E8, E15, E16, E17, E18, E22, E23, E26, E27, E33, E34, E62, E63, E64, E67, E69, E70, E71, E72)	I.C. 75452	1910645-01	67
1	E50	I.C. 7427	1910870	68
6	E9, E4, E30, E36, E48, E56	I.C. 8640	1911469	69
1	E13	I.C. 7450	1905680	70
1		HANDLE ASSY	1210711-02	71
12		EYELET	9006782	72
AR		WIRE, SOLID, INSULATED	9105740-55	73
AR		WIRE, SOLID, INSULATED	9107688-55	74
3	R114, R115 + R116	RES. 300 OHM, 1/4W, 5%	1301425	75
1	R65	RES. 68 OHM, 1/4W, 5%	1300219	76
9	R6, R10, R17, R23, R29, R43, R45, R47 + R107	RES 390 OHM, 1/2W, 5%	1300308	77
1	R81	RES 22K 1/4W 5%	1301808	78

SEE NOTE 1

REVISIONS		
CHK	CHANGE NO	REV

TITLE LOGIC AND WRITE BOARD (LAW2) SIZE CODE DCS NUMBER M8910-0-1 RE K
 SCALE SHEET 2 OF 9 DIST.

THIS DRAWING AND SPECIFICATIONS, HEREIN, ARE THE PROPERTY OF DIGITAL EQUIPMENT CORPORATION AND SHALL NOT BE REPRODUCED OR COPIED OR USED IN WHOLE OR IN PART AS THE BASIS FOR THE MANUFACTURE OR SALE OF ITEMS WITHOUT WRITTEN PERMISSION. COPYRIGHT © 1973, DIGITAL EQUIPMENT CORPORATION.

1-0-0168WJSD 2

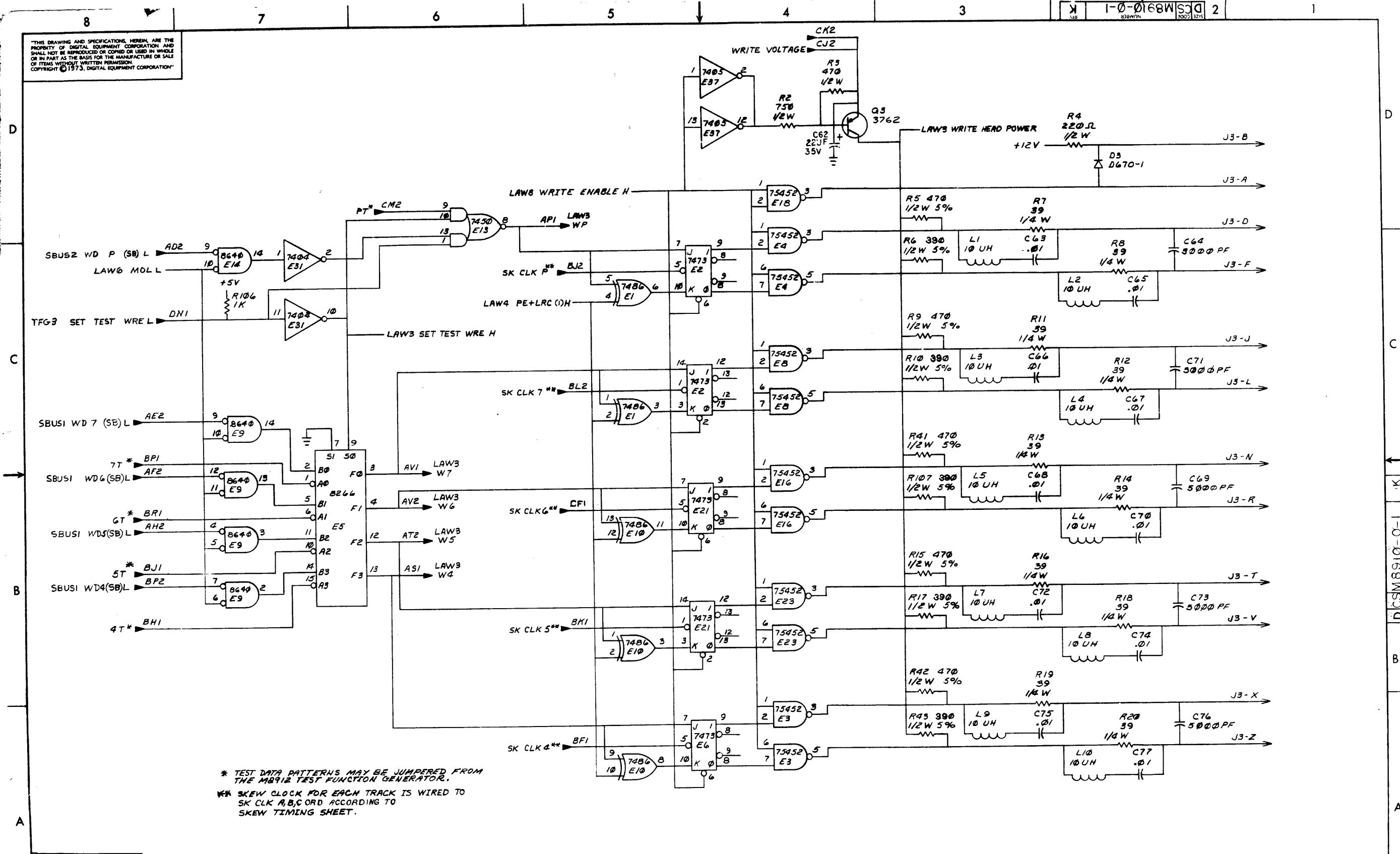

* TEST DATA PATTERNS MAY BE JUMPERED FROM THE M8912 TEST FUNCTION GENERATOR.
 ** SKEW CLOCK FOR EACH TRACK IS WIRED TO SK CLK A,B,C,ORD ACCORDING TO SKEW TIMING SHEET.

REVISIONS		
CHK	CHANGE NO.	REV.

TITLE	LOGIC AND WRITE BOARD (LAW3)	SIZE/CODE	D CS M8910-0-1	NUMBER	1	R.V.	K
SCALE	1:1	SHEET	3 OF 9	DIST.			

"THIS DRAWING AND SPECIFICATIONS HEREIN ARE THE PROPERTY OF DIGITAL EQUIPMENT CORPORATION AND SHALL NOT BE REPRODUCED OR COPIED OR USED IN WHOLE OR IN PART AS THE BASIS FOR THE MANUFACTURE OR SALE OF ITEMS WITHOUT WRITTEN PERMISSION. COPYRIGHT © 1973, DIGITAL EQUIPMENT CORPORATION"

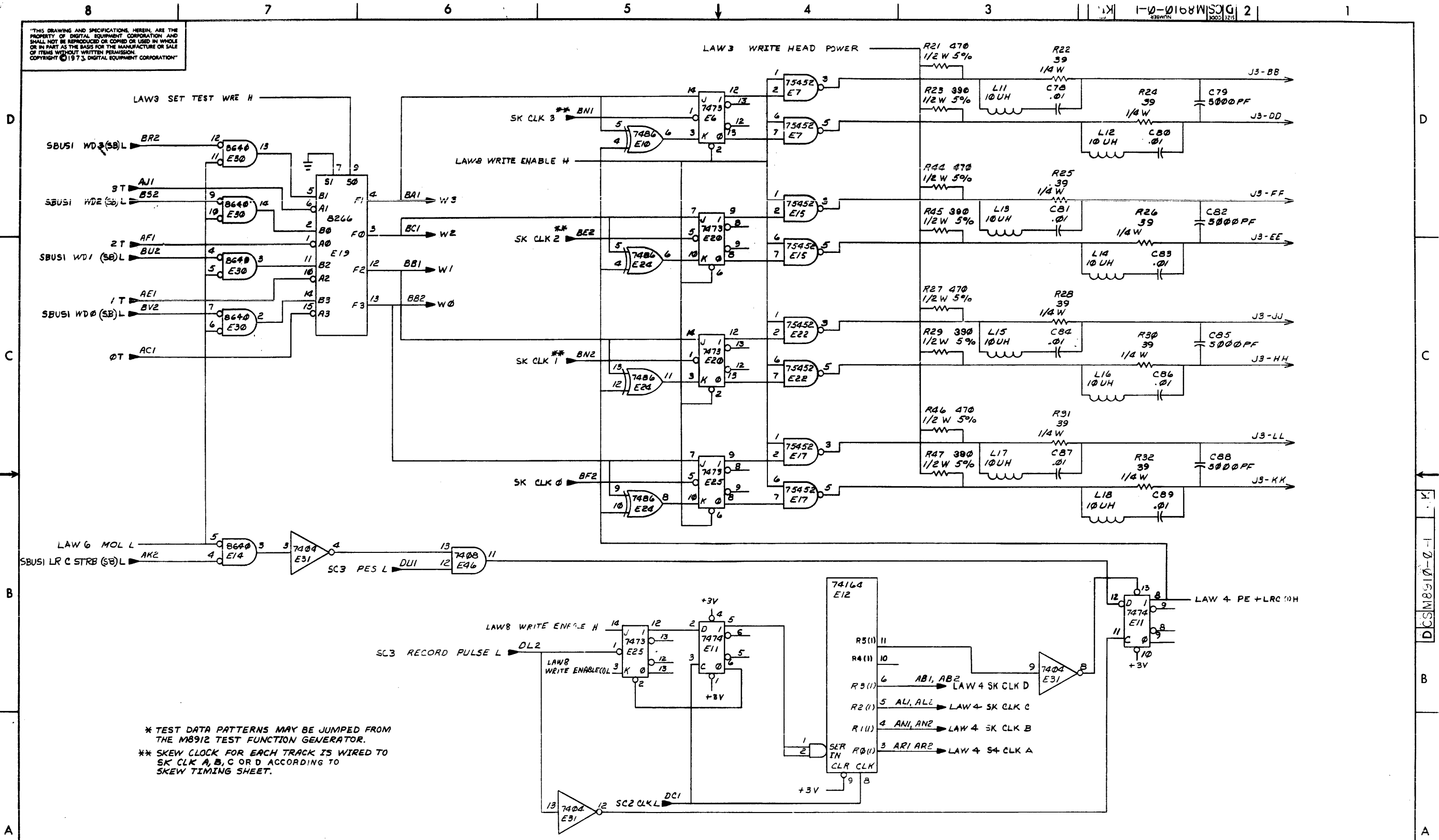

* TEST DATA PATTERNS MAY BE JUMPED FROM THE M8912 TEST FUNCTION GENERATOR.
 ** SKEW CLOCK FOR EACH TRACK IS WIRED TO SK CLK A, B, C OR D ACCORDING TO SKEW TIMING SHEET.

REVISIONS		
CHK	CHANGE NO	REV.

TITLE	LOGIC AND WRITE BOARD (LAW4)	SIZE CODE	D CS	NUMBER	M8910-0-1	REV.	K
SCALE	+	SHEET	4	OF	9	DIST.	

"THIS DRAWING AND SPECIFICATIONS, HEREIN, ARE THE PROPERTY OF DIGITAL EQUIPMENT CORPORATION AND SHALL NOT BE REPRODUCED OR COPIED OR USED IN WHOLE OR IN PART AS THE BASIS FOR THE MANUFACTURE OR SALE OF ITEMS WITHOUT WRITTEN PERMISSION. COPYRIGHT © 1973, DIGITAL EQUIPMENT CORPORATION"

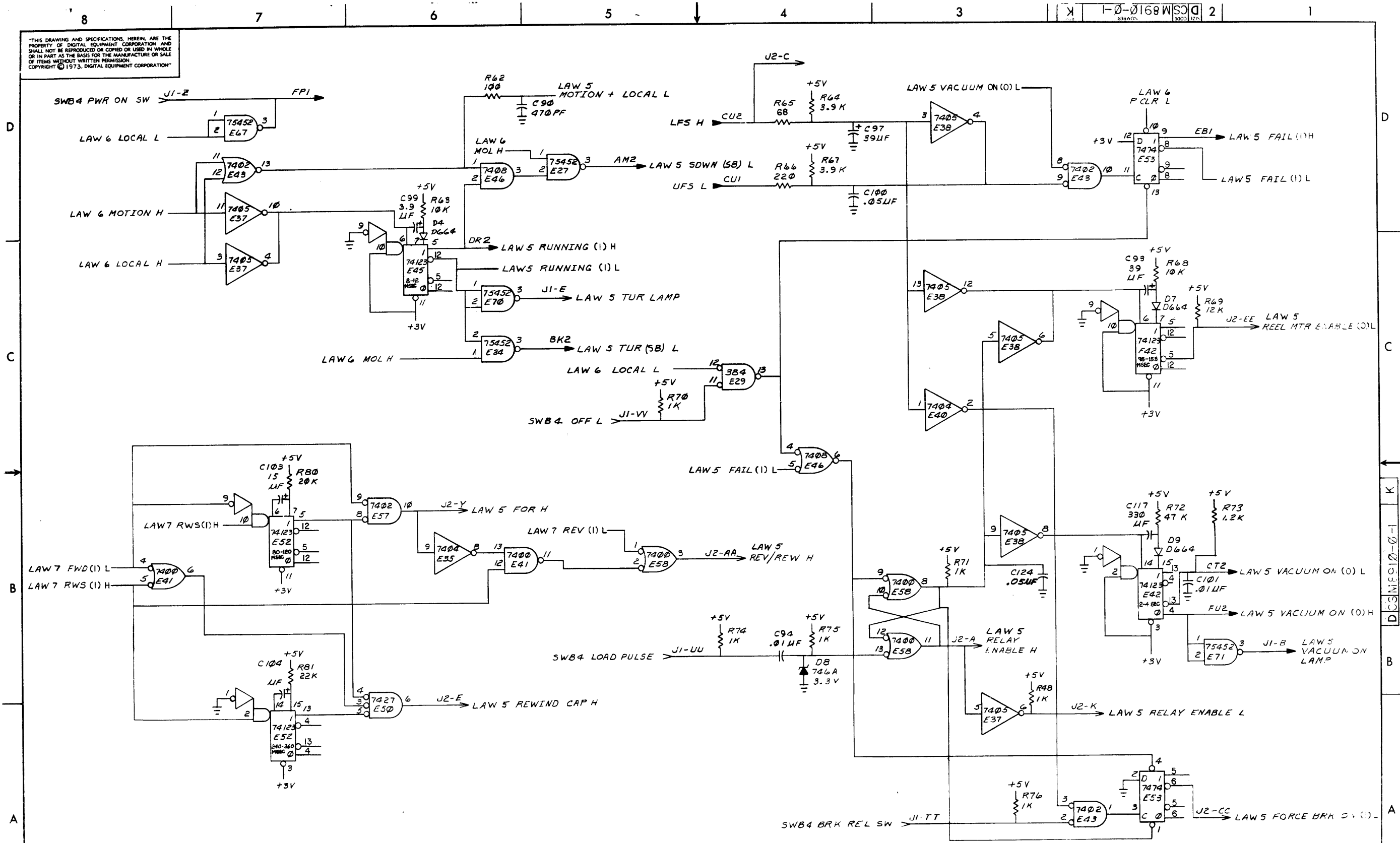

REVISIONS		
CHK	CHANGE NO.	REV.

TITLE	LOGIC AND WRITE BOARD (LAW 5)	SIZE CODE	D	NUMBER	CSM8910-2-1	REV	K
SCALE	SHEET 5 OF 5		DIST.				

THIS DRAWING AND SPECIFICATIONS HEREIN ARE THE PROPERTY OF DIGITAL EQUIPMENT CORPORATION AND SHALL NOT BE REPRODUCED OR COPIED OR USED IN WHOLE OR IN PART AS THE BASIS FOR THE MANUFACTURE OR SALE OF ITEMS WITHOUT WRITTEN PERMISSION. COPYRIGHT © 1973, DIGITAL EQUIPMENT CORPORATION

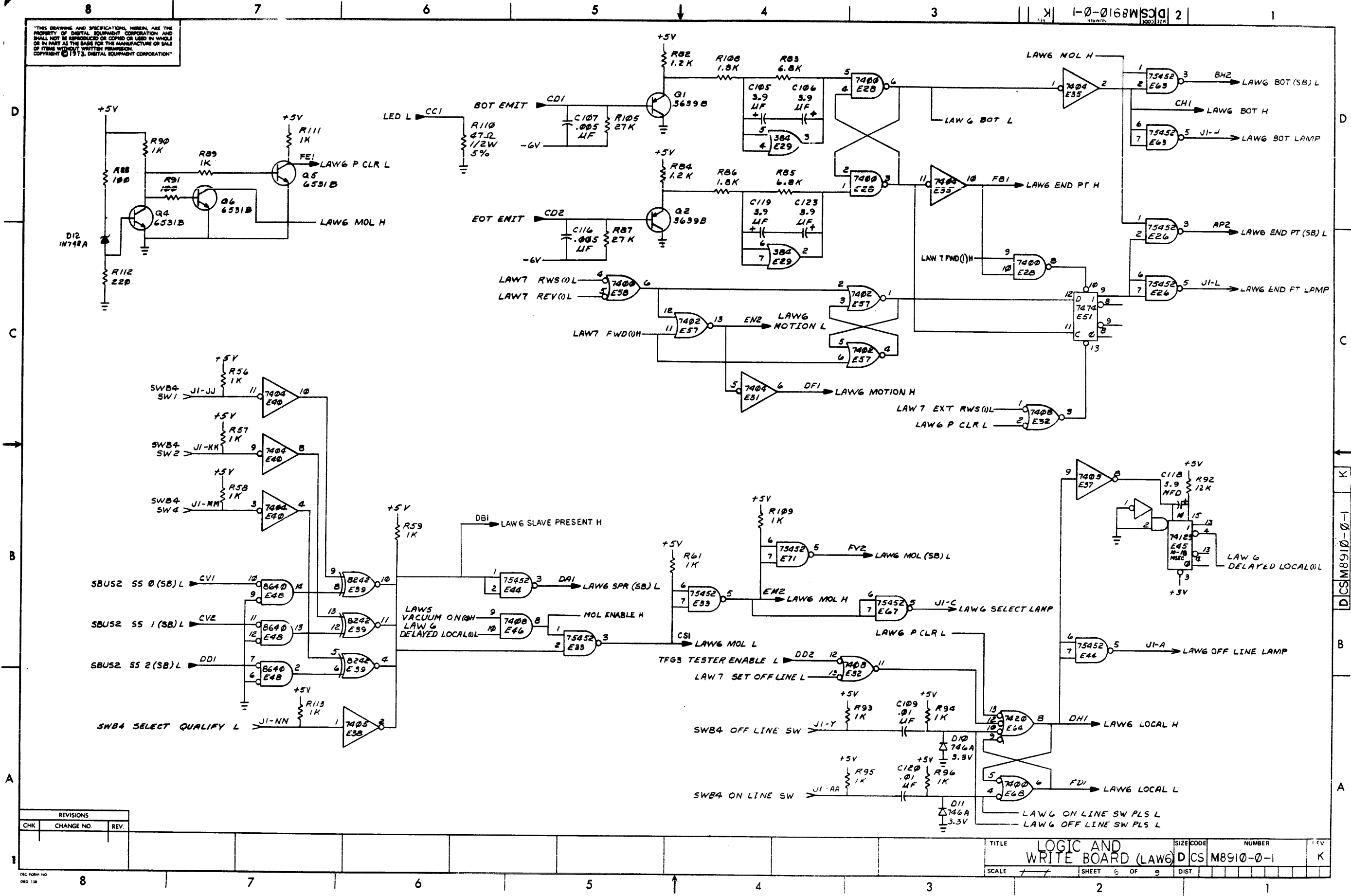

REVISIONS		
CHK	CHANGE NO	REV.

THIS DRAWING AND SPECIFICATIONS HEREIN ARE THE PROPERTY OF DIGITAL EQUIPMENT CORPORATION AND SHALL NOT BE REPRODUCED OR COPIED OR USED IN WHOLE OR IN PART AS THE BASIS FOR THE MANUFACTURE OR SALE OF ITEMS WITHOUT WRITTEN PERMISSION. COPYRIGHT © 1973, DIGITAL EQUIPMENT CORPORATION.

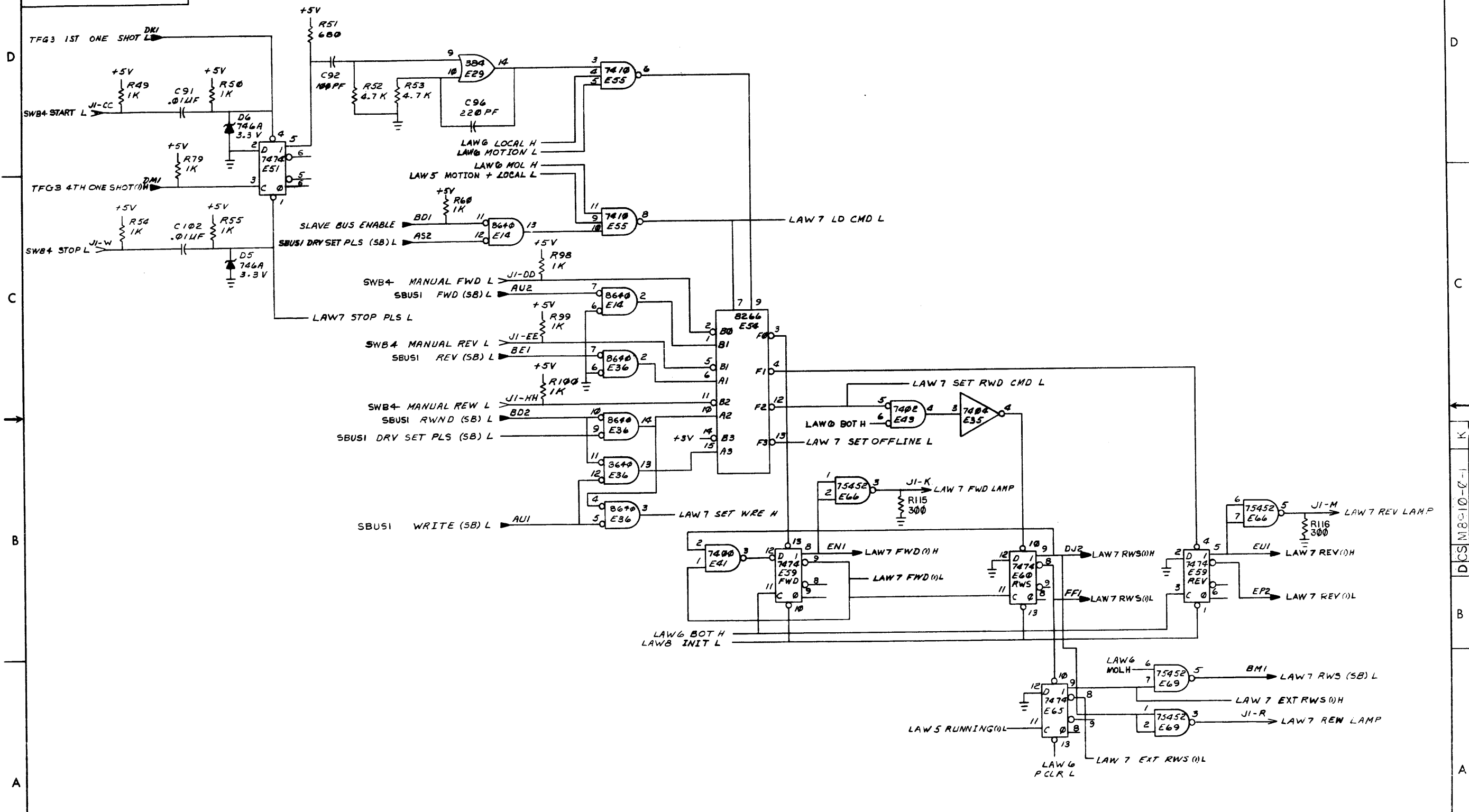

REVISIONS		
CHK	CHANGE NO.	REV

THIS DRAWING AND SPECIFICATIONS HEREIN ARE THE PROPERTY OF DIGITAL EQUIPMENT CORPORATION AND SHALL NOT BE REPRODUCED OR COPIED OR USED IN WHOLE OR IN PART AS THE BASIS FOR THE MANUFACTURE OR SALE OF ITEMS WITHOUT WRITTEN PERMISSION. COPYRIGHT © 1973, DIGITAL EQUIPMENT CORPORATION.

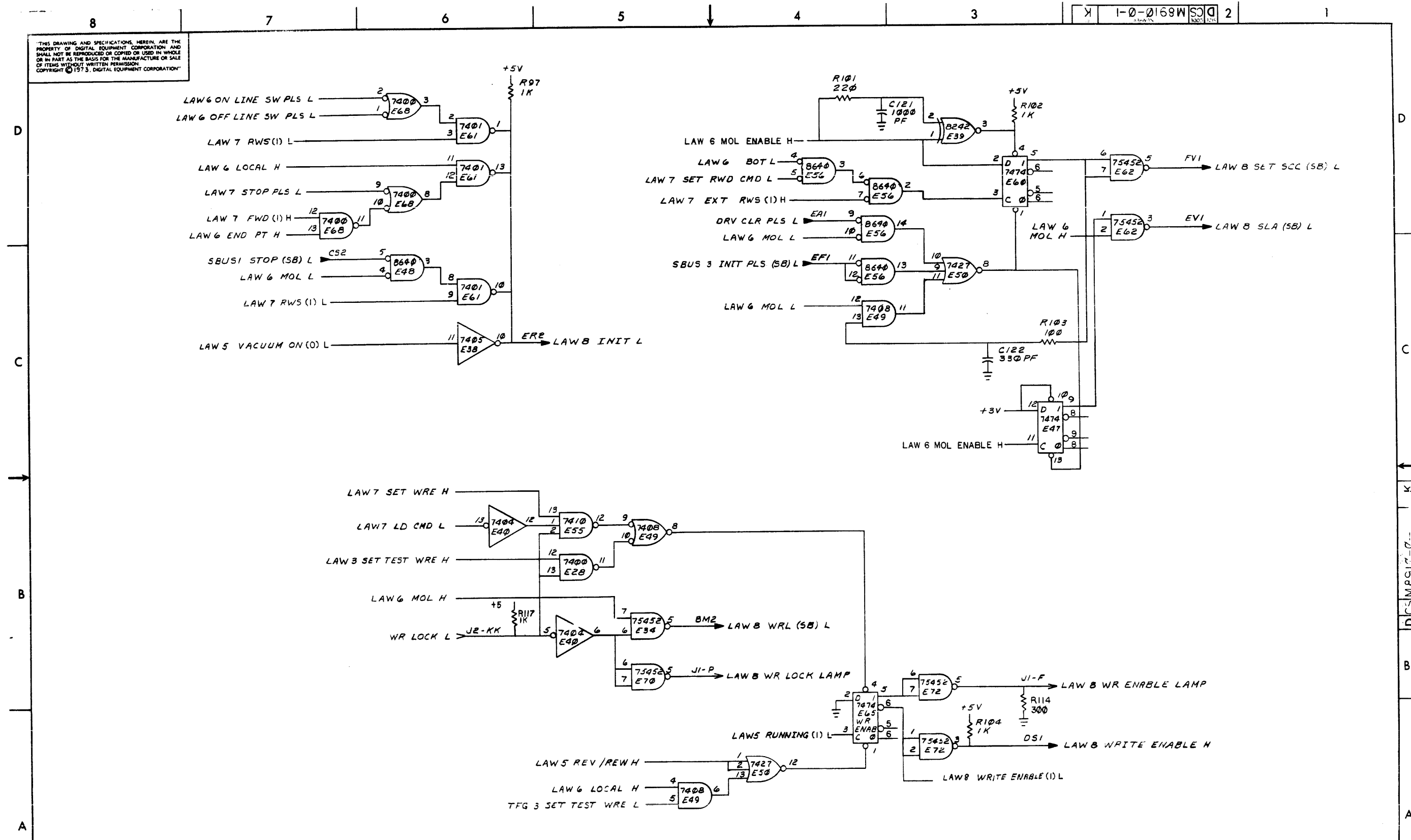

REVISIONS		
CHK	CHANGE NO	REV

TITLE	LOGIC AND WRITE BOARD (LAW 6)	SIZE CODE	D C S M P C 10-0-	NUMBER	
SCALE		SHEET	8 OF 9	DIST.	

"THIS DRAWING AND SPECIFICATIONS HEREIN ARE THE PROPERTY OF DIGITAL EQUIPMENT CORPORATION AND SHALL NOT BE REPRODUCED OR COPIED OR USED IN WHOLE OR IN PART AS THE BASIS FOR THE MANUFACTURE OR SALE OF ITEMS WITHOUT WRITTEN PERMISSION. COPYRIGHT © 1973, DIGITAL EQUIPMENT CORPORATION"

SWITCH BOX CONNECTOR

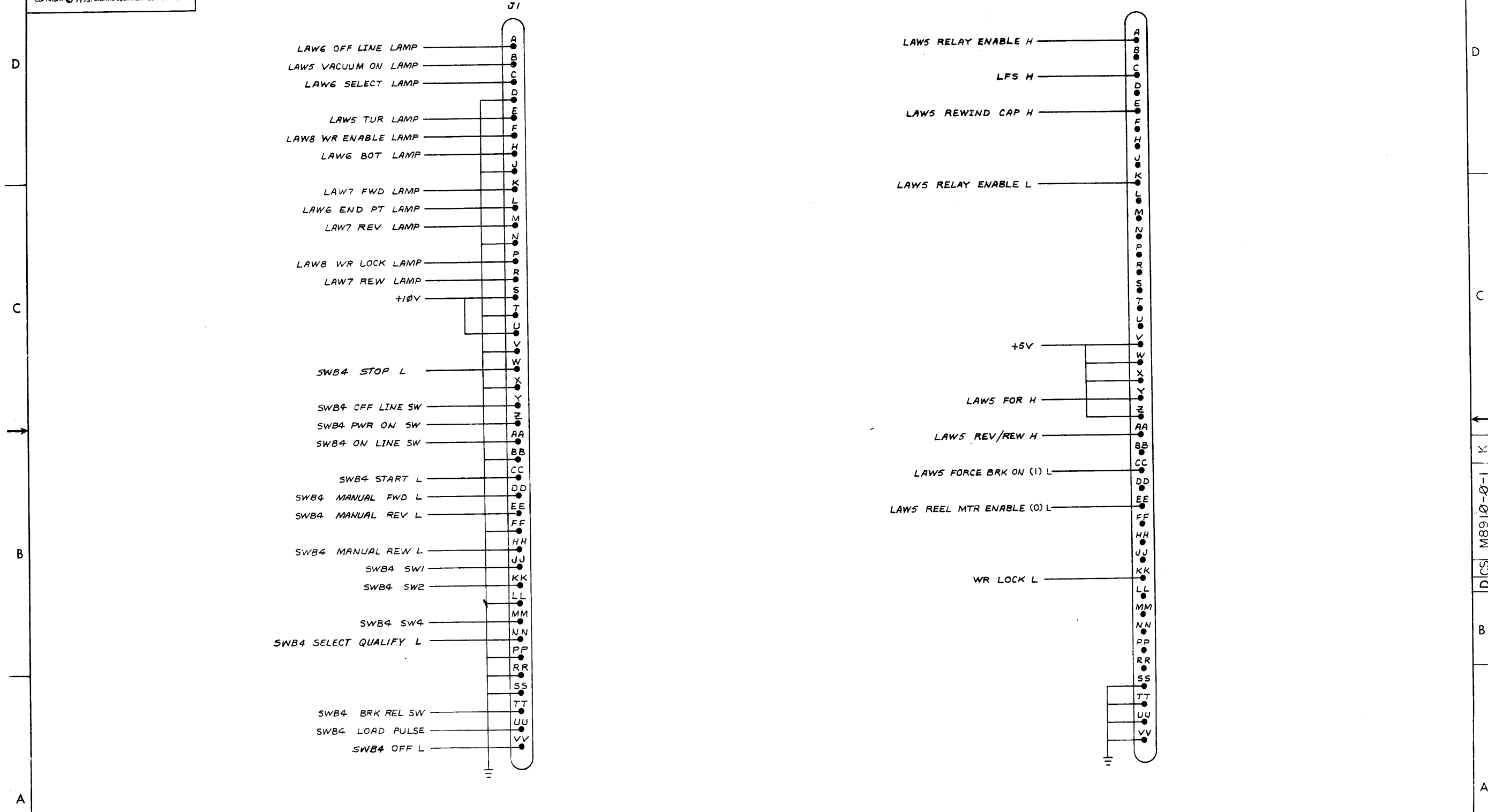

REVISIONS		
CHK	CHANGE NO	REV

"THIS DRAWING AND SPECIFICATIONS, HEREIN, ARE THE PROPERTY OF DIGITAL EQUIPMENT CORPORATION AND SHALL NOT BE REPRODUCED OR COPIED OR USED IN WHOLE OR IN PART AS THE BASIS FOR THE MANUFACTURE OR SALE OF ITEMS WITHOUT WRITTEN PERMISSION. COPYRIGHT © 1973, DIGITAL EQUIPMENT CORPORATION"

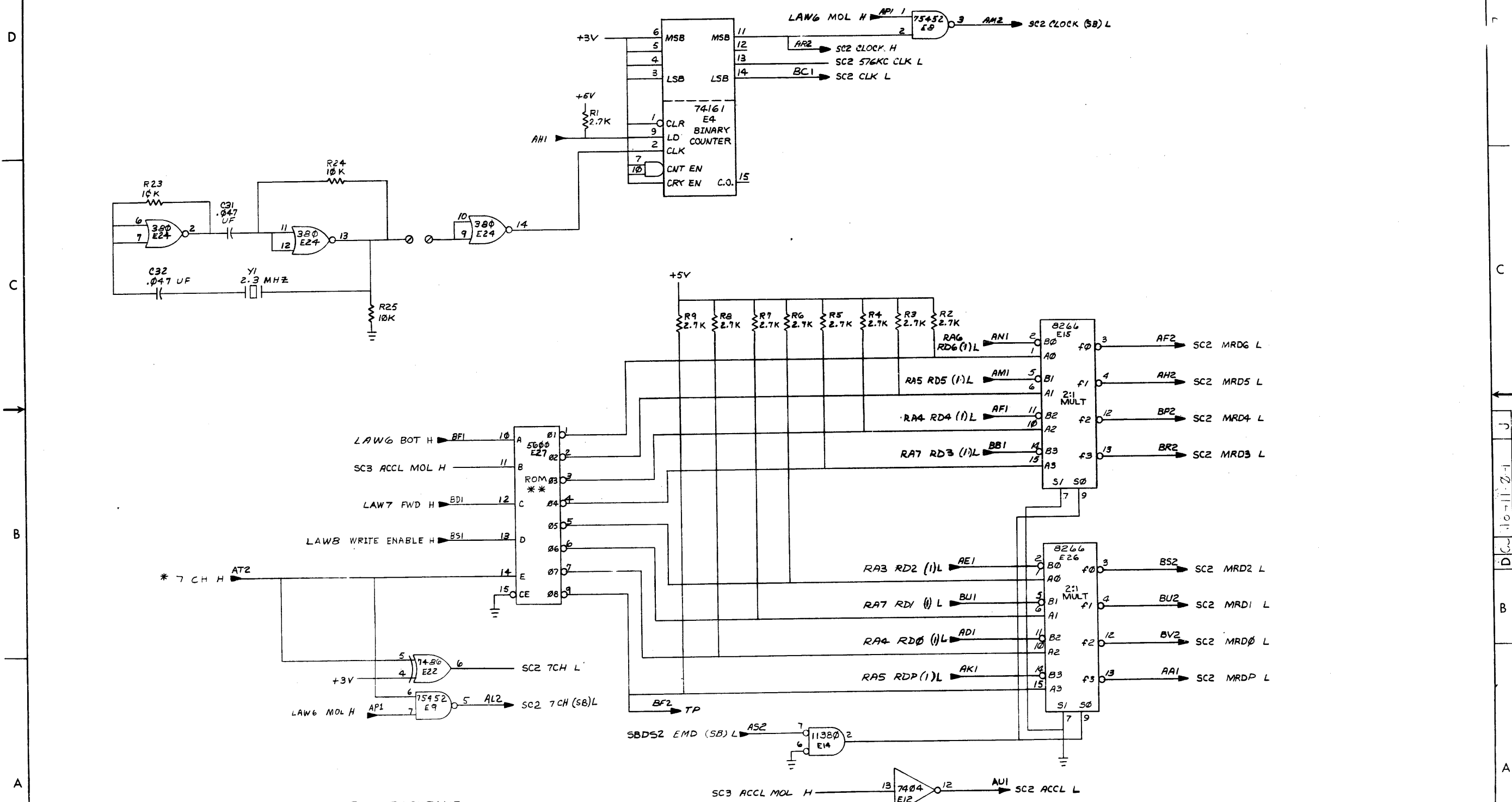

REVISIONS		
CHK	CHANGE NO	REV

* SIGNALS ORIGINATE ON BACKPANEL
 ** SEE PARTS LIST FOR CORRECT ROM PART NUMBER

PROPERTY OF DIGITAL EQUIPMENT CORPORATION
 SHALL NOT BE REPRODUCED OR COPIED OR USED IN WHOLE
 OR IN PART AS THE BASIS FOR THE MANUFACTURE OR SALE
 OF ITEMS WITHOUT WRITTEN PERMISSION.
 COPYRIGHT © 1973, DIGITAL EQUIPMENT CORPORATION

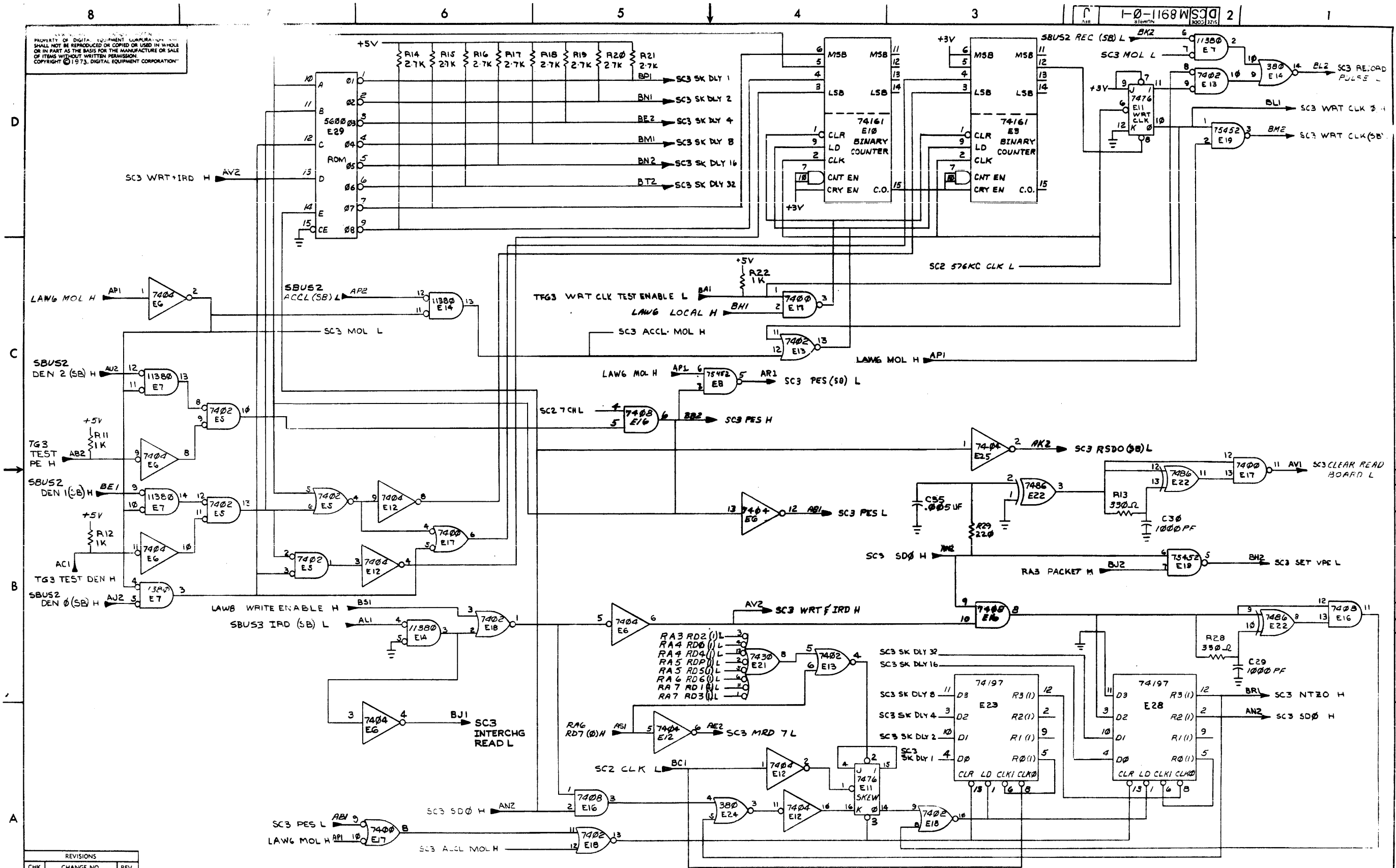

REVISIONS		
CHK	CHANGE NO	REV

TITLE: SLAVE CLK MOTION DLY (SC3) SIZE CODE: DCS M8411-0-1 NUMBER: 30F3 REV. J
 SCALE: / / SHEET: 30F3 DIST.:

DCS M8411-0-1

"THIS DRAWING AND SPECIFICATIONS, HEREIN, ARE THE PROPERTY OF DIGITAL EQUIPMENT CORPORATION AND SHALL NOT BE REPRODUCED OR COPIED OR USED IN WHOLE OR IN PART AS THE BASIS FOR THE MANUFACTURE OR SALE OF ITEMS WITHOUT WRITTEN PERMISSION. COPYRIGHT © 1975, DIGITAL EQUIPMENT CORPORATION"

NOTES:

DASH VAR	DESCRIPTION
-01	TWO PARTS IN ONE 16 PIN CARRIER

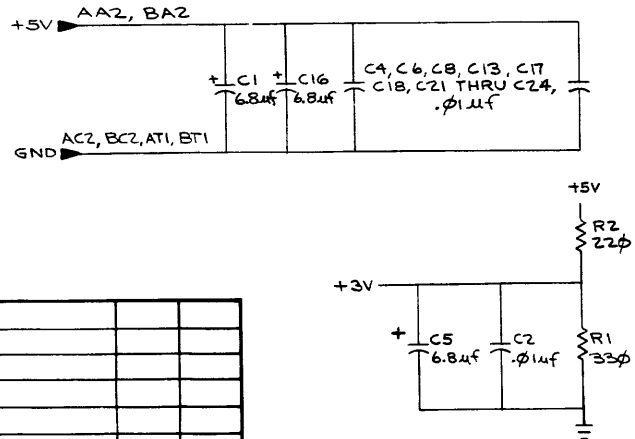
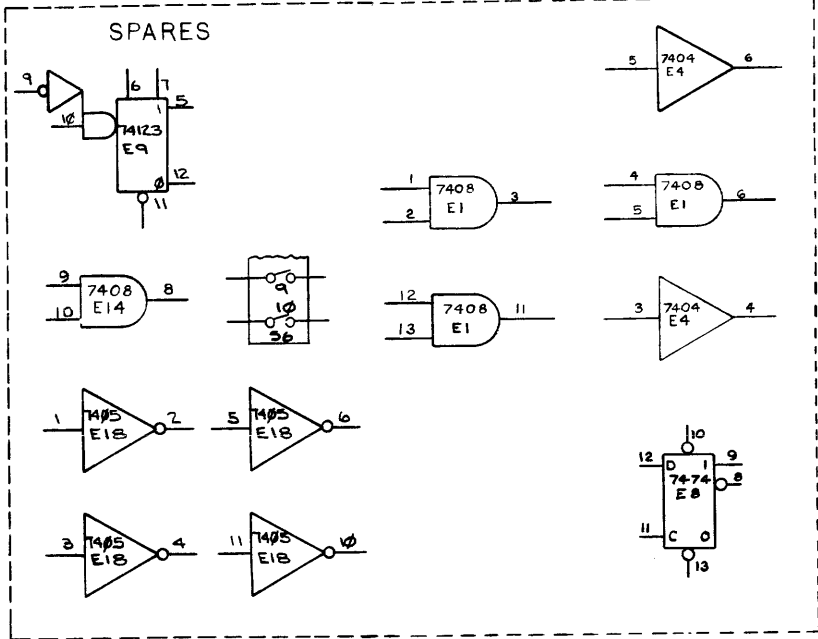

IC TYPE	GND	+5V
74199	12	24
7452	4	8
74123	8	16

GND AND 5V ARE USUALLY PIN 7 AND 14 RESPECTIVELY. EXCEPTIONS ARE STATED ABOVE

IC PIN LOCATIONS

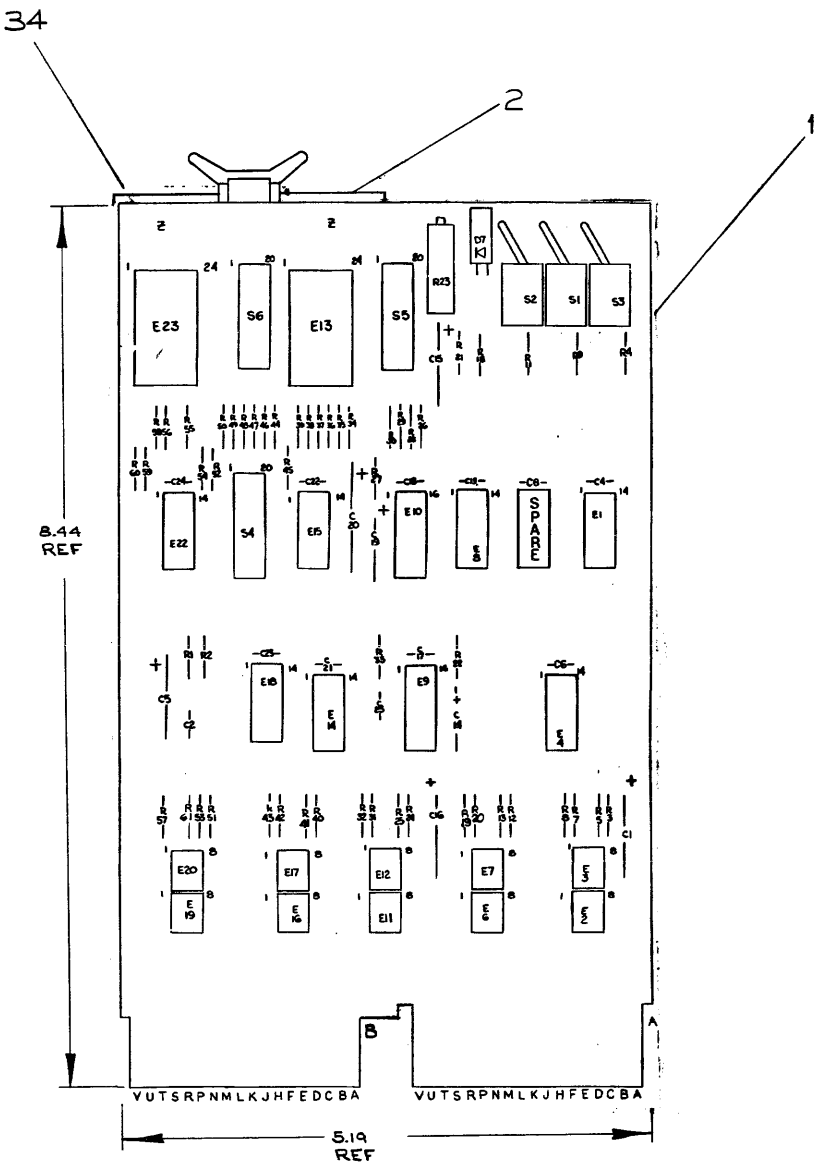

REF	DESCRIPTION	PART NO.	ITEM NO.	
REF	X-Y COORDINATE HOLE LOCATION	K-00-M8912-0-4	REF	
REF	ASSY/DRILLING HOLE LAYOUT	D-AH-M8912-0-5	REF	
REF	MODULE ECO HISTORY	B-MH-M8912-0-6	REF	
1	ETCHED CIRCUIT BOARD	5010674	1	
1	HANDLE, FLIP-CHIP, MAGENTA	9008337-06	2	
			3	
1	C25	CAP 470 P F 100V 5% D.M.	1000024	4
2	C4, C19	CAP 3.9uF 100V 10% TANT	1000064	5
11	C2, C4, C7, C18, C21-24, C6, C8, C13	CAP .01uF 100V 20% DISC	1001610-01	6
1	C15	CAP 10uF 20V 10% TANT	1004813	7
1	C20	CAP 100uF 20V 10% TANT	1004815	8
3	C1, C5, C16	CAP 6.8uF 35V 10% TANT	1005306	9
			10	
1	D7	DIODE, LIGHT EMITTING	1110324	11
1	R33	RES 150 1/4 W 5%	1300250	12
1	R2	RES 220 1/4 W 5%	1300271	13
1	R1	RES 330 1/4 W 5%	1300295	14
5	R4, R8, R11, R10, R61	RES 1K 1/4 W 5%	1300365	15
43	R3, R5, R7, R9, R12, R13, R14 THRU R21, R24, R25, R26, R28 THRU R32, R34 THRU R39, R41 THRU R60	RES 4.7K 1/4 W 5%	1300447	16
1	R22	RES 10K 1/4 W 5%	1300479	17
1	R27	RES 15K 1/4 W 5%	1300496	18
1	R18	RES 270 1/4 W 5%	1301972	19
1	R23	RES 50K 3/4 W 10% 76 PR	1309143-13	20
			21	
			22	
			23	
1	E4	IC 7404	1909686	24
2	E15, E22	IC 74197	1910035	25
2	E1, E14	IC 7408	1910155	26
2	E9, E10	IC 74123	1910436	27
5	E2, E3, E6, E7, E11, E12, E16, E17, E19, E20	IC 7452	1910645-01*	28
2	E13, E23	IC 74199	1910842	29
1	E8	IC 7474	1905347	30
1	E18	IC 7405	1909930	31
3	S1, S2, S3	SWITCH, TOGGLE	1210209-00	32
3	S4, S5, S6	SWITCH, DIP OF 10	1211164-06	33
2		EYELET	9006732	34

* NOTE

FIRST USED ON OPTION MODEL
TU16

ETCH BOARD REV **D**

DATE 12-5-75
DRN E. Nichols
CHKD J. Carberry
ENG J.R. Hess
PROJ ENG J.R. Hess
DATE 11/2/74
DATE 11/2/74
DATE 11-2-74

digital EQUIPMENT CORPORATION
MAYNARD, MASSACHUSETTS

TITLE
**SLAVE TEST (TFGI)
FUNCTION GENERATOR**

SIZE CODE NUMBER REV.
DCS M8912-0-1 D

SCALE 1 OF 3
SHEET 1 OF 3

SEMICONDUCTOR CONVERSION CHART

REV	CHANGE NO.	DESCRIPTION
1		INITIAL DESIGN
2		REVISIONS
3		REVISIONS
4		REVISIONS
5		REVISIONS
6		REVISIONS
7		REVISIONS
8		REVISIONS
9		REVISIONS
10		REVISIONS

THIS DRAWING AND SPECIFICATIONS HEREIN ARE THE PROPERTY OF DIGITAL EQUIPMENT CORPORATION AND SHALL NOT BE REPRODUCED OR COPIED OR USED IN WHOLE OR IN PART AS THE BASIS FOR THE MANUFACTURE OR SALE OF ITEMS WITHOUT WRITTEN PERMISSION. COPYRIGHT © 1973, DIGITAL EQUIPMENT CORPORATION

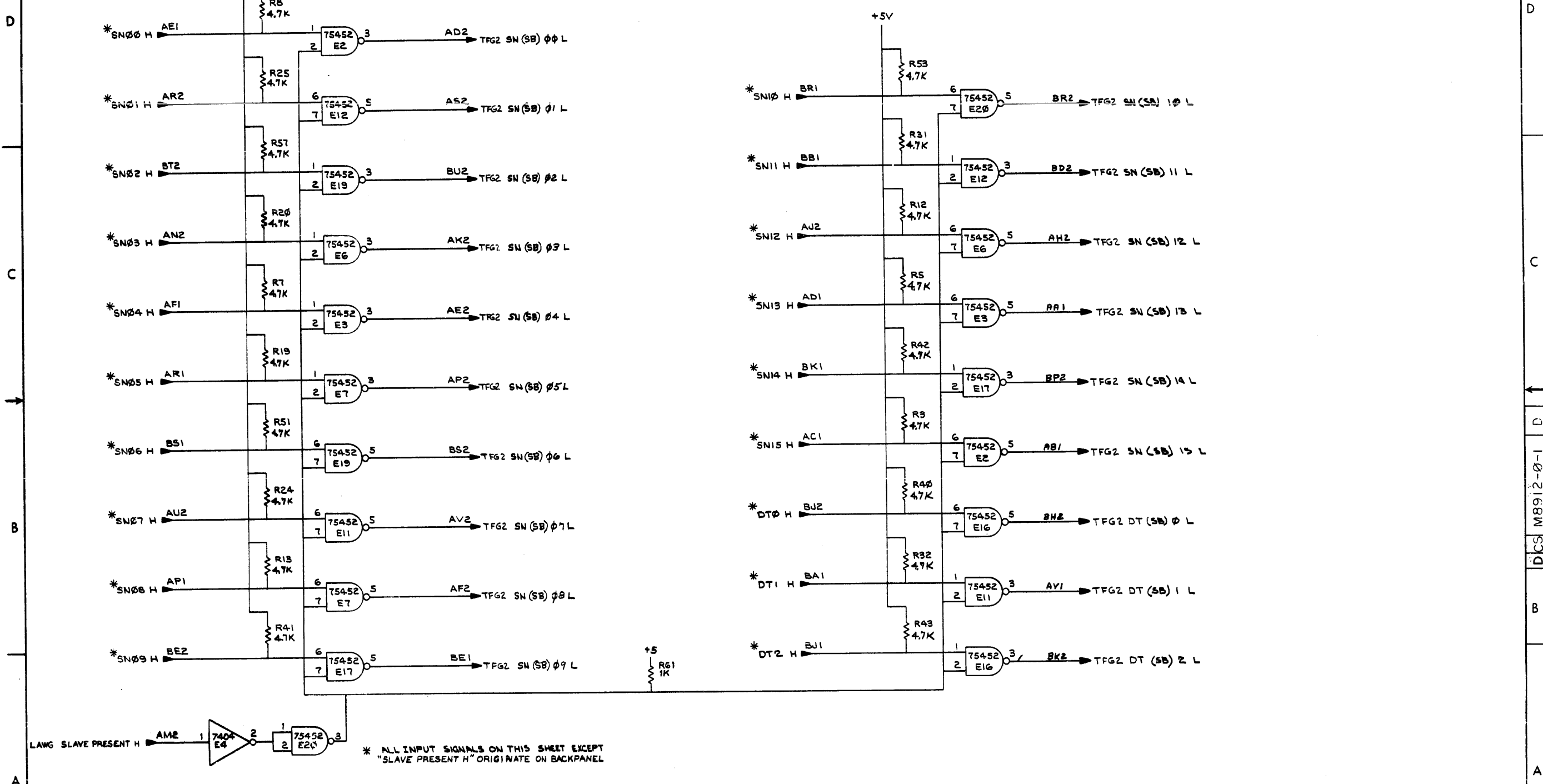

REVISIONS		
CHK	CHANGE NO	REV

TITLE	SLAVE TEST (TFG2) FUNCTION GENERATOR	SIZE CODE	DCS	NUMBER	M8912-0-1	REV.	D
SCALE	+	SHEET	2	OF	3	DIST.	

"THIS DRAWING AND SPECIFICATIONS, HEREIN, ARE THE PROPERTY OF DIGITAL EQUIPMENT CORPORATION AND SHALL NOT BE REPRODUCED OR COPIED OR USED IN WHOLE OR IN PART AS THE BASIS FOR THE MANUFACTURE OR SALE OF ITEMS WITHOUT WRITTEN PERMISSION. COPYRIGHT © 1973, DIGITAL EQUIPMENT CORPORATION"

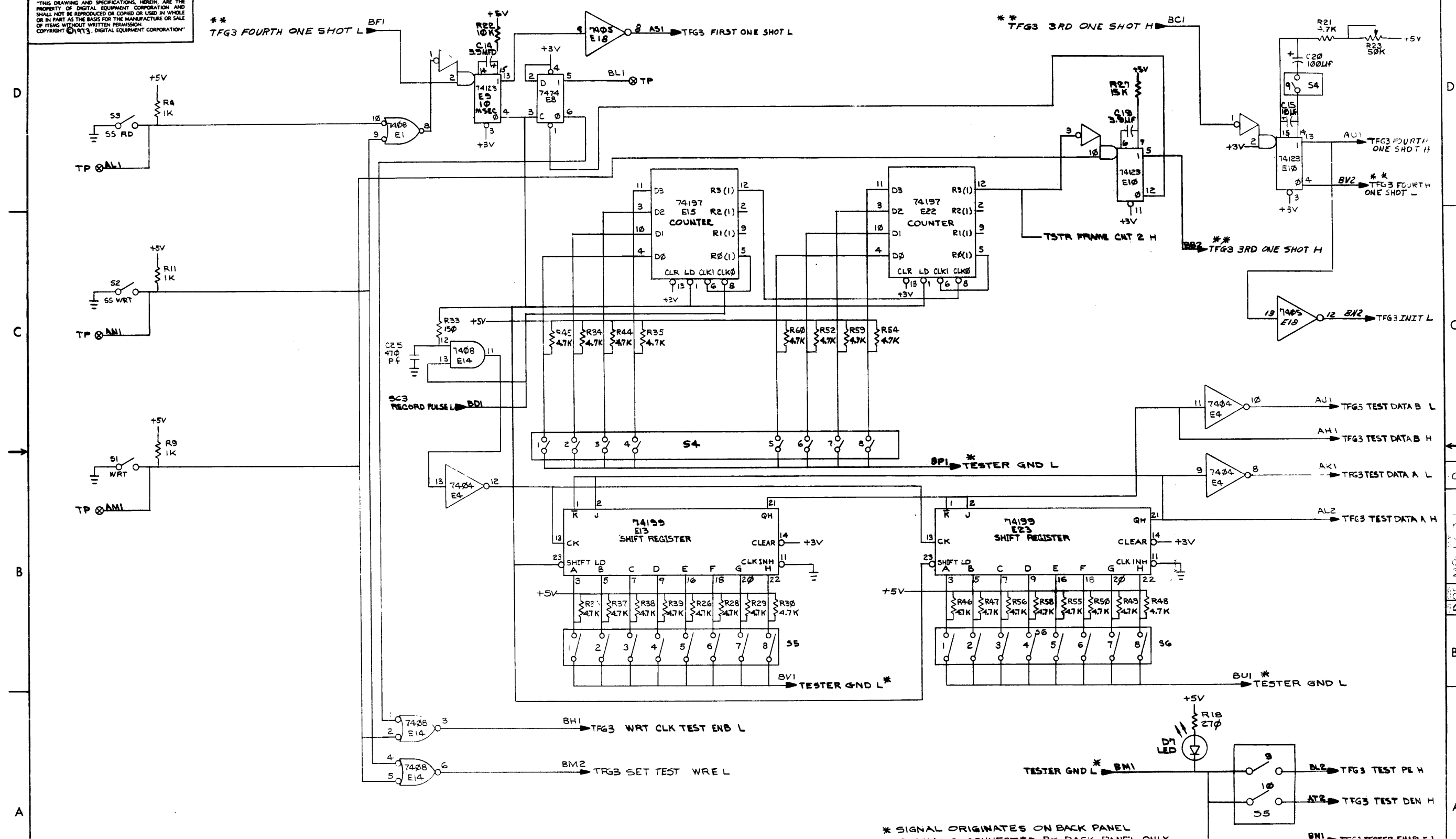

* SIGNAL ORIGINATES ON BACK PANEL
 ** SIGNALS CONNECTED BY BACK PANEL ONLY

REVISIONS		
CHK	CHANGE NO	REV

TITLE	SLAVE TEST (TFG3) FUNCTION GENERATOR	SIZE CODE	D CS	NUMBER	M6912-0-1	REV.	D
SCALE		SHEET	3	OF	3	DIST.	

THIS DRAWING AND SPECIFICATIONS HEREIN ARE THE PROPERTY OF DIGITAL EQUIPMENT CORPORATION AND SHALL NOT BE REPRODUCED OR COPIED OR USED IN WHOLE OR IN PART AS THE BASIS FOR THE MANUFACTURE OR SALE OF ITEMS WITHOUT WRITTEN PERMISSION.
 COPYRIGHT © 1973 DIGITAL EQUIPMENT CORPORATION

- NOTES:**
- UNLESS OTHERWISE SPECIFIED:
 ALL RESISTORS ARE 1/4 W 5%
 ALL CAPACITORS ARE 100V 20%.
 - MOUNT ITEM # 21 AND Q16, Q20, Q34, Q35, Q37, Q38, Q39, Q41, Q42, Q44, Q46, Q47, Q50, Q51, R129, R133, R139, R143 AFTER WAVE SOLDER.

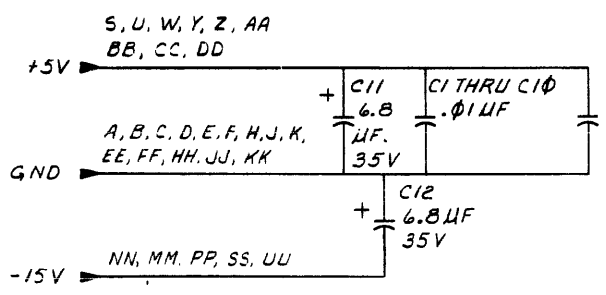
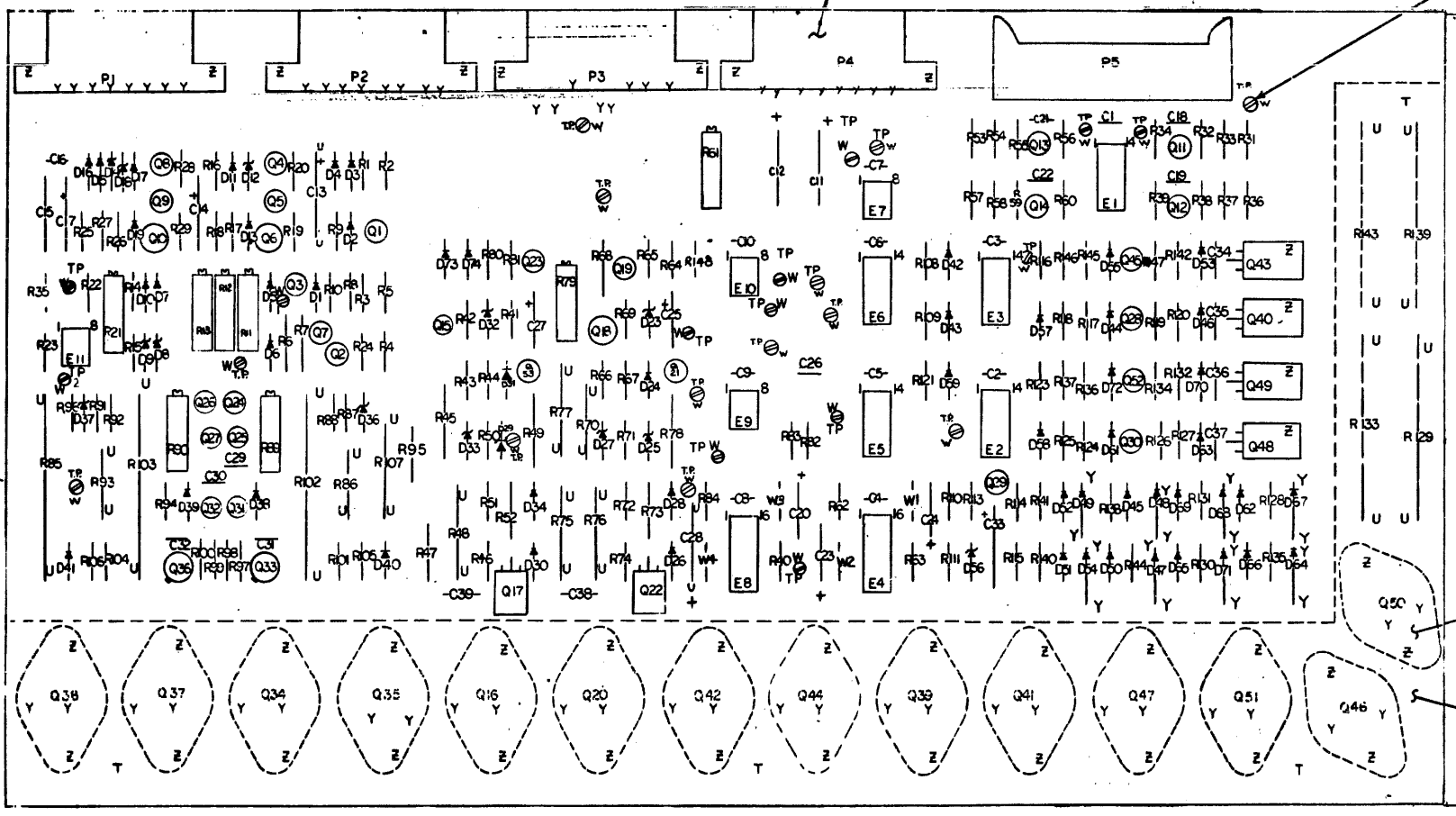

IC TYPE	GND	+5V
75452	4	8
75451	4	8
74123	8	16
741	4	7

GND AND 5V ARE USUALLY PIN 7 AND 14 RESPECTIVELY. EXCEPTIONS ARE STATED ABOVE.

IC PIN LOCATIONS

REV	CHANGE NO.	DATE	BY
1		31 DEC 1973	W. SMITH
2		6 JAN 74	H. DRAB
3		31 DEC 1973	W. SMITH
4		31 DEC 1973	W. SMITH
5		31 DEC 1973	W. SMITH
6		31 DEC 1973	W. SMITH
7		31 DEC 1973	W. SMITH
8		31 DEC 1973	W. SMITH
9		31 DEC 1973	W. SMITH
10		31 DEC 1973	W. SMITH

QTY	REF DESIGNATION	DESCRIPTION	PART NO.	ITEM NO.

ETCH BOARD REV D

SEMICONDUCTOR CONVERSION CHART

DEC NO.	EIA NO.	DEC NO.	EIA NO.

REVISIONS

CHK	CHANGE NO.	DATE	BY

DRN V. Bismilla DATE 10-18-73
CHK'D Carberry DATE 12/19/73
ENG John Hess DATE 1-4-74
PRD John Hess DATE 1-4-74
FRD John Hess DATE 11/27/74

digital EQUIPMENT CORPORATION
 MAYNARD MASSACHUSETTS

TITLE (DRVR 1)
TU16 POWER BOARD

SCALE 1 OF 6
 SHEET 1 OF 6

SIZE CODE NUMBER REV.
 DCS H606-0-1 E

DCS H606-0-1

"THIS DRAWING AND SPECIFICATIONS, HEREIN, ARE THE PROPERTY OF DIGITAL EQUIPMENT CORPORATION AND SHALL NOT BE REPRODUCED OR COPIED OR USED IN WHOLE OR IN PART AS THE BASIS FOR THE MANUFACTURE OR SALE OF ITEMS WITHOUT WRITTEN PERMISSION. COPYRIGHT © 1973, DIGITAL EQUIPMENT CORPORATION"

8		7		6		5		4		3		2		1	
QTY	REF DESIGNATION	DESCRIPTION	PART NO.	ITEM NO	QTY	REF DESIGNATION	DESCRIPTION	PART NO.	ITEM NO	QTY	REF DESIGNATION	DESCRIPTION	PART NO.	ITEM NO	
REF		X-Y COORDINATE HOLE LOCATION	K-CD-H606-0-4	REF 2	R43, R66	RES 560 1/4W 5%	1301890		47						
REF		ASSY/DRILLING HOLE LAYOUT	D-AH-H606-0-5	REF 5	R46, R74, R94, R98, R99	RES 270 1/4W 5%	1301872		48						
REF		MODULE ECO HISTORY	B-MH-H606-0-6	REF 2	R52, R73	RES 39 1/4W 5%	1302336		49						
1		ETCHED CIRCUIT BOARD	5010481	1	R10	RES 20K 1/4W 5%	1302391		50						
1	C15	CAP .027UF 100V 10% NYLAR	1000049	2	R22	RES 470K 1/4W 5%	1302398		51						
5	C20, C23, C24, C27, C25	CAP 3.9UF 10V 10% S TANT	1000064	3	R84	RES 33K 1/4W 10%	1300510		52						
2	C13, C28	CAP 180UF 6V 20% S. TANT	1000086	4	R128, R130, R131, R135, R138, R140, R141, R144	RES 56 1/4W 5%	1302602		53						
18	C1 THRU C10, C16, C18, C19, C21, C22, C26, C29, C30	CAP .01UF 100V 20% DISC	1001610-01	6	R75, R77	RES 56 2W 5%	1302636		54						
4	C11, C12, C14, C17	CAP 6.8UF 35V 10% S. TANT	1005306	7	R88, R92	RES 2K 1/4W 5%	1302388		55						
2	C31, C32	CAP .02UF	1000004	8	R114	RES 620 1/4W 5%	1303178		56						
1	C33	CAP 68UF 15V 10% S. TANT	1000082	9	R32, R38, R44, R55, R59, R67, R113	RES 8, 2K 1/4W 5%	1303179		57						
23	D1 THRU D7, D10, D11, D13, D17, D19, D38, D39, D42, D43, D44, D55, D57, D58, D59, D61, D72	DIODE D664	1100114	10	R107	RES 120 2W 5%	1305282		58						
2	D23, D32	DIODE IN 748A ZENER	1100122	11	R129, R133, R139, R143	RES 56 10W 1%	1305396		59						
7	D8, D9, D12, D14, D18, D36, D37	DIODE IN 750A ZENER	1100124	12	R102, R103	RES 12 10W 5%	1305400		60						
4	D40, D41, D73, D74	DIODE IN 4004	1105796	13	R76, R48	RES 27 2W 10%	1305624		61						
2	D27, D33	DIODE IN 4736A ZENER	1103340	14	R85	RES .1 10W 1%	1309108		62						
3	D25, D29, D56	DIODE IN 756A ZENER	1103441	15	R79	POT 100 1/4W 10% 76PR	1309143-04		63						
20	D50 THRU D53, D62, D63, D65, D66, D69, D70, D15, D16, D24, D26, D28, D30, D31, D34, D45, D46	DIODE D672	1105275	16	R89, R90	POT 1K 1/4W 10% 76PR	1309143-07		64						
8	D47, D48, D49, D54, D64, D67, D68, D71	DIODE 5624	1110420	17	R11	POT 5K 1/4W 10% 76PR	1309143-09		65						
4	P1, P2, P3, P4	CONN MATE-N-LOK 8 PIN	1209340	18	R12, R13	POT 10K 1/4W 10% 76PR	1309143-10		66						
32		SOCKET TERMINAL CONTACT	1209458	19	R21, R61	POT 25K 1/4W 10% 76PR	1309143-12		67						
1	P5	CONN 40P RT ANG HEADER	1209941	20	Q10, Q33	TRANS DEC 2904	1501742		68						
1		HEAT SINK	74-11390	21	Q6, Q36	TRANS DEC 2219	1501881		69						
2	R105, R106	RES 47 1/4W 5%	1300202	22	Q18	TRANS DEC 2904A	1501913		70						
1	R47	RES 56 1/4W 5%	1309995	23	Q37, Q41, Q44, Q50, Q51	TRANS DEC 3715	1503088		71						
2	R101, R104	RES 100 1/4W 5%	1300229	24	Q1, Q2, Q3, Q29, Q5, Q8, Q21, Q23, Q26, Q27, Q32, Q53	TRANS DEC 6534D	1503409		72						
3	R50, R71, R83	RES 220 1/4W 5%	1300271	25	Q4, Q7, Q9, Q11 THRU Q15, Q19, Q24, Q25, Q28, Q30, Q31, Q45, Q52	TRANS DEC 6531B	1509338		73						
2	R45, R70	RES 220 1W 10%	1300277	26	Q16, Q20, Q34, Q39, Q42, Q46, Q47	TRANS DEC 3791	1509581		74						
2	R7, R6	RES 270 1/4W 5%	1300285	27	Q17, Q22	TRANS DEC 4923	1509604		75						
9	R82, R119, R120, R126, R127, R132, R134, R142, R147	RES 330 1/4W 5%	1300295	28	Q35	TRANS DEC 4502	1510334		76						
2	R86, R93	RES 330 1W 5%	1300297	29	Q38	TRANS DEC 802	1510335		77						
1	R8	RES 470 1/4W 5%	1300316	30	Q40, Q43, Q48, Q49	TRANS D 4500	1510598		78						
1	R68	RES 750 1/4W 5%	1300354	31	E5	IC DEC 7400	1905575		79						
24	R15, R17, R19, R20, R26, R25, R29, R31, R33, R36, R37, R51, R53, R54, R57, R58, R72, R87, R91, R116, R123, R137, R146, R48	RES 1K 1/4W 5%	1300365	32	E6	IC DEC 7410	1905576		80						
14	R1, R4, R24, R42, R65, R69, R80, R81, R97, R100, R110, R111, R118, R125	RES 1.5K 1/4W 5%	1300391	33	E1	IC DEC 7402	1909004		81						
3	R35, R41, R64	RES 2.2K 1/4W 5%	1300417	34	E2, E3	IC DEC 380	1909485		82						
3	R108, R109, R121	RES 3.3K 1/4W 5%	1300439	35	E11	IC DEC 741	1910298		83						
3	R2, R5, R96	RES 3.9K 1/4W 5%	1300444	36	E9	IC DEC 75451	1910406		84						
2	R9, R115	RES 10K 1/4W 5%	1300479	37	E4, E8	IC DEC 74123	1910436		85						
5	R34, R39, R56, R60, R62	RES 12K 1/4W 5%	1300488	38	E7, E10	IC DEC 75452	1910645		86						
2	R18, R27	RES 15K 1/4W 5%	1300496	39	A/R	THERMAL COMPOUND	9008268		87						
5	R23, R117, R124, R136, R145	RES 68K 1/4W 5%	1301327	40	2B	SCREW, BD HD 4-40X7-16 LG	9006012-4		88						
2	R16, R25	RES 27 1/4W 5%	1301522	41	32	KEPNUT 4-40	9006557		89						
2	R3, R14	RES 6.8K 1/4W 5%	1301423	42	8	WASHER, NYLON	9006706		90						
2	R49, R78	RES .82 1/4W 10%	1301642	43	14	WASHER, ANODIZED	9006721		91						
1	R95	RES 47 1/4W 5%	1301695	44	8	EYELET	9006745		92						
1	R63	RES 22K 1/4W 5%	1301808	45	26	CAMBION TERMINAL	9007791		93						
1	R40	RES 5.6K 1/4W 5%	1301874	46	6	C34 THRU C39	CAP .1UF 100V 20% DISC	1000030	94						
					4		EYELET	9006746	95						
					4		SCREW, ED HD 4-40 X5-16 LG	9006010-4	96						
					4		TUBING #22 THIN WALL	9007256	97						
					4		GRIPLET	121C244	98						
					4	W1 THRU W4	JUMPER, WIRE, WHITE INSULATION	9009185	99						

SECTIONS		
CHK	CHANGE NO	REV

TITLE	DRVR2	SIZE CODE	NUMBER	REV.
TU16 POWER BOARD		DCS	H606-0-1	E
SCALE	2 OF 6	DIST.		

THIS DRAWING AND SPECIFICATIONS HEREIN ARE THE PROPERTY OF DIGITAL EQUIPMENT CORPORATION AND SHALL NOT BE REPRODUCED OR COPIED OR USED IN WHOLE OR IN PART AS THE BASIS FOR THE MANUFACTURE OR SALE OF ITEMS WITHOUT WRITTEN PERMISSION. COP. RIGHT © 1973, DIGITAL EQUIPMENT CORPORATION.

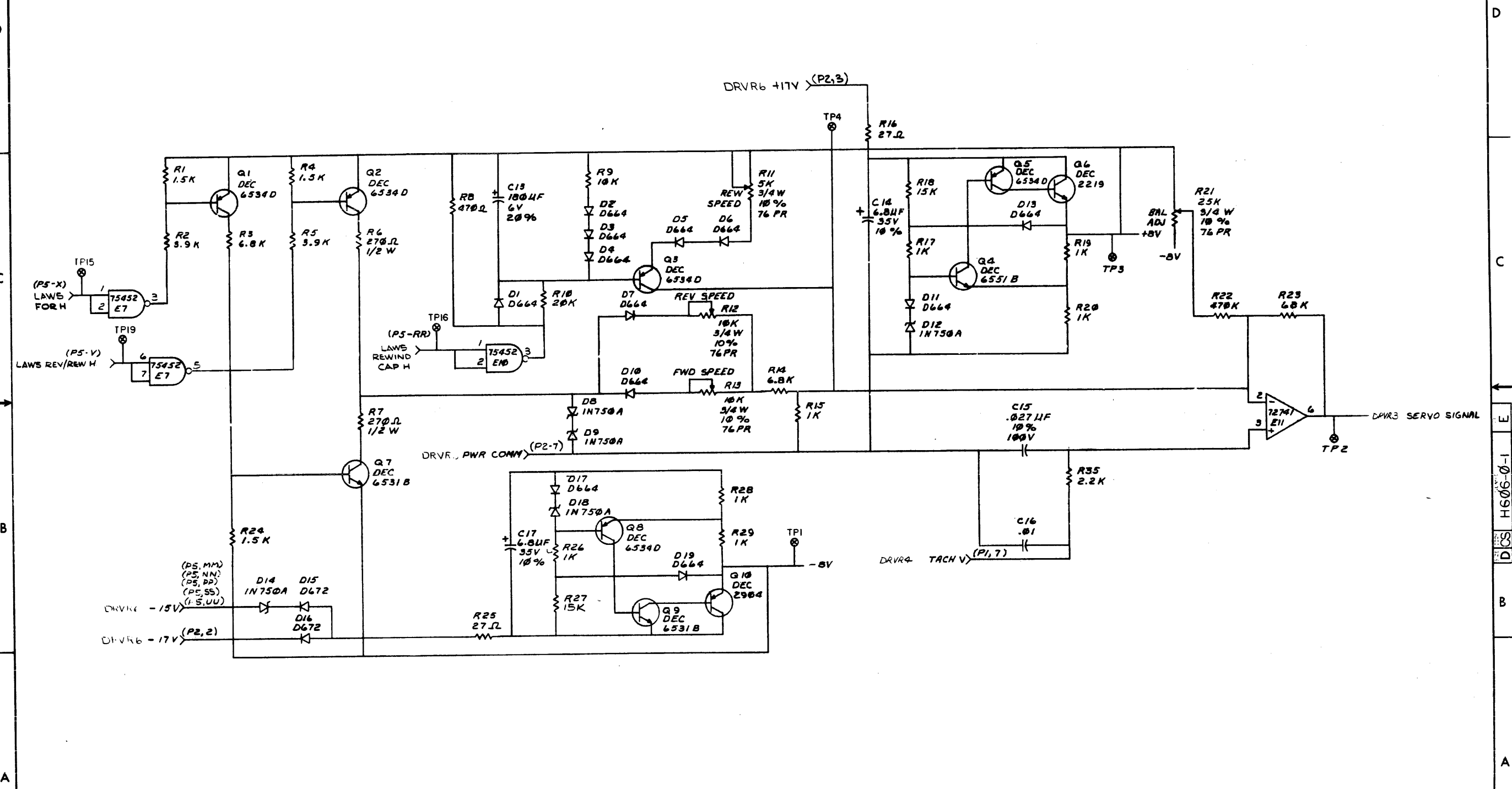

REVISIONS		
CHK	CHANGE NO	REV

TITLE	(DRVR3)	SIZE	CODE	NUMBER	REV.
TU16 POWER BOARD	DCS	H606-0-1			E
SCALE	SHEET 3	OF	DIST.		

DCS H606-0-1

"THIS DRAWING AND SPECIFICATIONS HEREIN ARE THE PROPERTY OF DIGITAL EQUIPMENT CORPORATION AND SHALL NOT BE REPRODUCED OR COPIED OR USED IN WHOLE OR IN PART AS THE BASIS FOR THE MANUFACTURE OR SALE OF ITEMS WITHOUT WRITTEN PERMISSION. COPYRIGHT © 1975, DIGITAL EQUIPMENT CORPORATION"

D
C
B
A

D
C
B
A

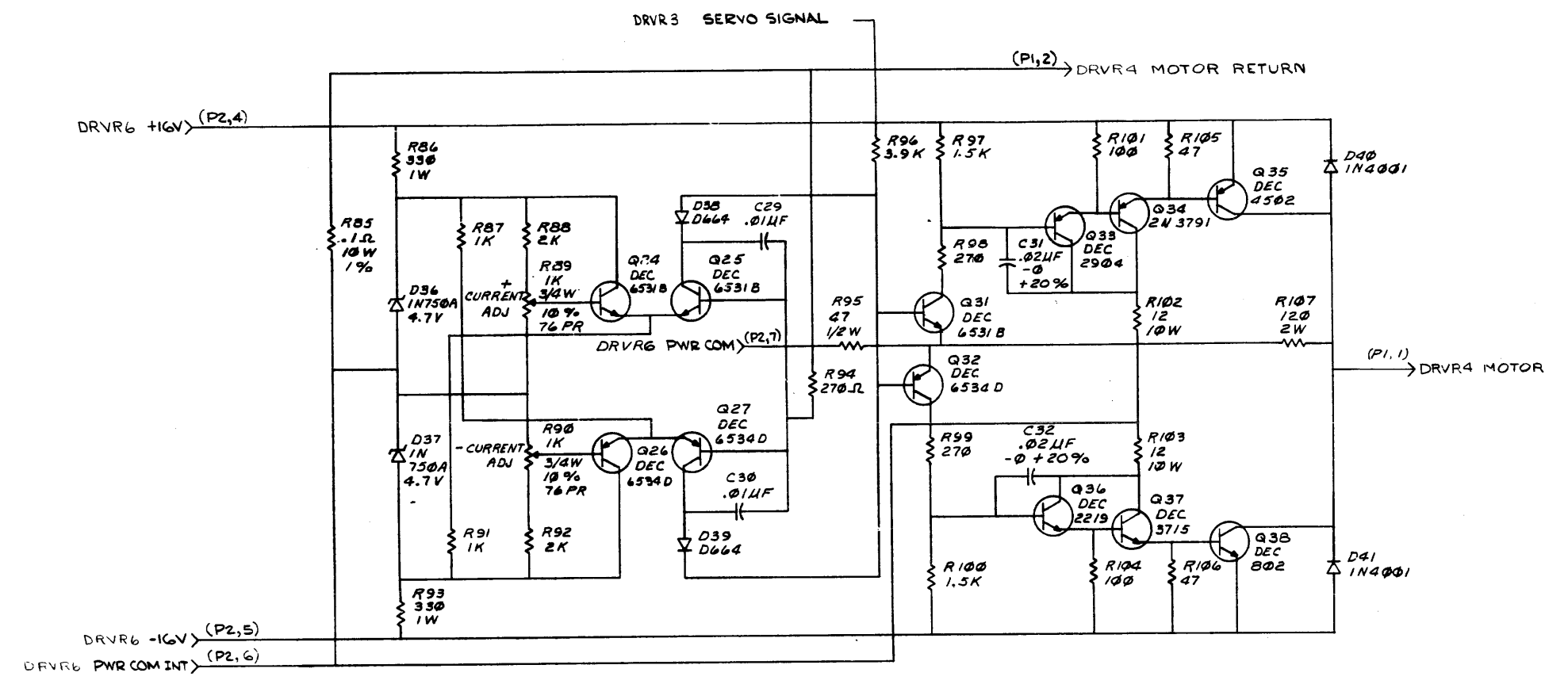
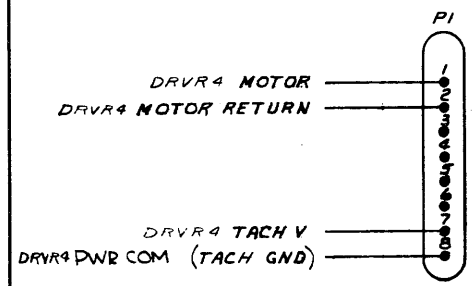

REVISIONS		
CHK	CHANGE NO	REV

TITLE	(DRVR4)	SIZE CODE	NUMBER	REV.
TU16 POWER BOARD	D CS	H606-0-1	E	
SCALE	SHEET 4	OF 6	DIST.	

THE DIMENSIONS AND SPECIFICATIONS SHOWN ARE THE PROPERTY OF DIGITAL EQUIPMENT CORPORATION AND SHALL NOT BE REPRODUCED OR COPIED OR USED IN WHOLE OR IN PART AS THE BASIS FOR THE MANUFACTURE OR SALE OF ITEMS WITHOUT WRITTEN PERMISSION. COPYRIGHT © 1975, DIGITAL EQUIPMENT CORPORATION.

1-0-909H SCD 2

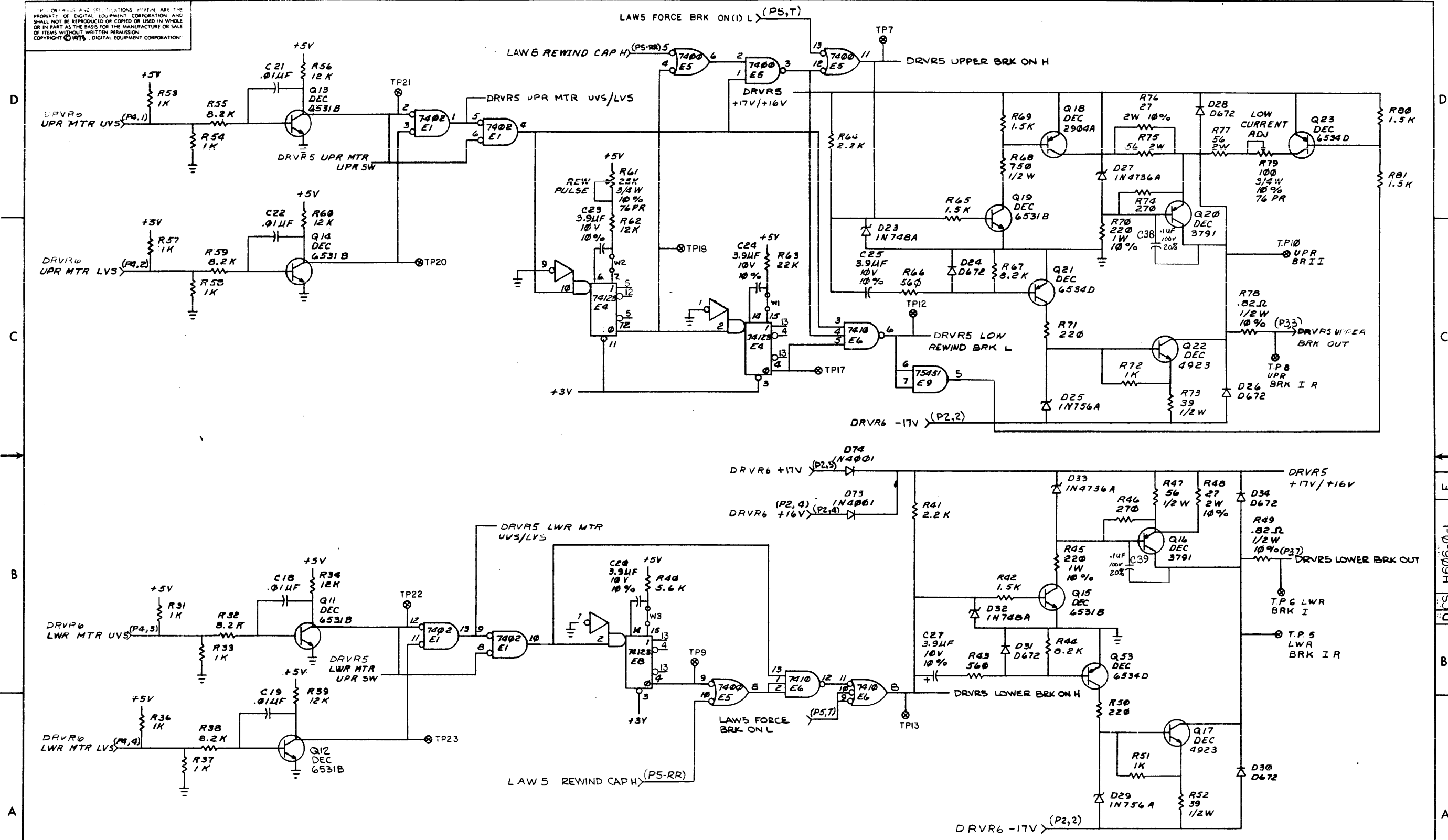

REVISIONS		
CHK	CHANGE NO	REV

TITLE	(DRVR5) TU16 POWER BOARD	SIZE CODE	DCS	NUMBER	H606-0-1	REV.	E
SCALE	1/4"	SHEET	5	OF	6	DIST.	

8 7 6 5 4 3 2 1

THIS DRAWING AND SPECIFICATIONS HEREIN ARE THE PROPERTY OF DIGITAL EQUIPMENT CORPORATION AND SHALL NOT BE REPRODUCED OR COPIED OR USED IN WHOLE OR IN PART AS THE BASIS FOR THE MANUFACTURE OR SALE OF ITEMS WITHOUT WRITTEN PERMISSION. COPYRIGHT © 1975, DIGITAL EQUIPMENT CORPORATION.

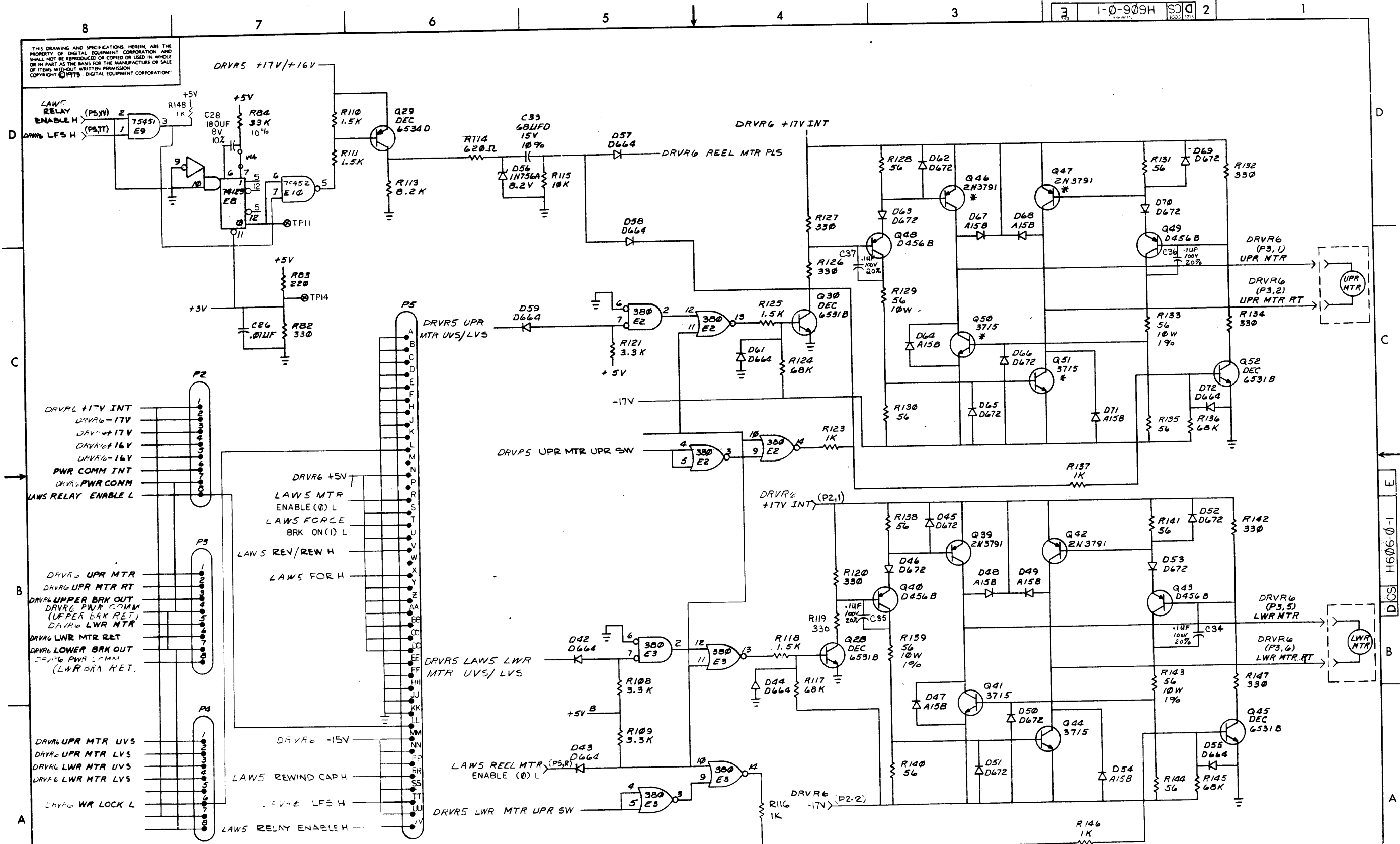

REVISIONS		
CHK	CHANGE NO	REV

TITLE	(DRV6)	SIZE CODE	NUMBER	REV.
TUI6 POWER BOARD	D CS	H606-0-1	1	E
SCALE	SHEET 6 OF 6	DIST.		

"THIS DRAWING AND SPECIFICATIONS HEREIN ARE THE PROPERTY OF DIGITAL EQUIPMENT CORPORATION AND SHALL NOT BE REPRODUCED OR COPIED OR USED IN WHOLE OR IN PART AS THE BASIS FOR THE MANUFACTURE OR SALE OF ITEMS WITHOUT WRITTEN PERMISSION. COPYRIGHT © 1975, DIGITAL EQUIPMENT CORPORATION"

NOTES:

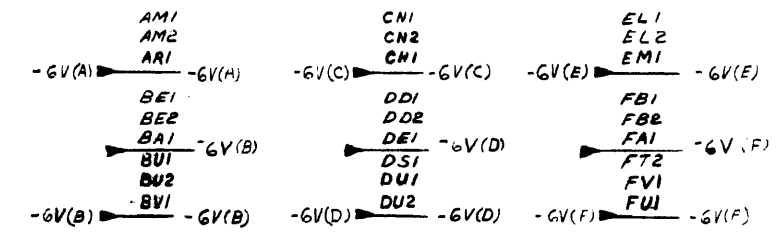

TRACK NUMBER	BINARY REFERENCE
1	RD2
2	RD0
3	RD4
4	RDP
5	RD5
7	RD7
8	RD1
9	RD3

WRE H	PES L	Y3	Y2	Y1	Y0
A	B	PIN4	PIN5	PIN6	PIN7
PE	0	0	1	1	0
PE	1	0	1	1	0
NRZ	0	1	1	0	1
NRZ	1	1	0	1	1

CH.	IN	7486	OUT	75107	IN	7476	OUT	DIGITAL	ANALOG
CH. 1	9,10 (E10)	8	AJ1	1,2	E1	14	AB1	AL1	
CH. 2	12,13 (E10)	11	AH1	6,7	E1	10	AF1	BB1	
CH. 3	9,10 (E21)	8	BN1	1,2	E12	14	BF1	BM1	
CH. 4	12,13 (E21)	11	BL1	6,7	E12	10	BK1	CM1	
CH. 5	9,10 (E32)	8	CU1	1,2	E23	14	CP1	CL1	
CH. 6	12,13 (E32)	11	CS1	6,7	E23	10	CR1	DP1	
CH. 7	9,10 (E43)	8	EH1	1,2	E34	15	DV1	DR1	
CH. 8	12,13 (E43)	11	EF1	6,7	E34	10	EE1	FP1	
CH. 9	9,10 (E52)	8	FM1	1,2	E45	14	FK1	FR1	

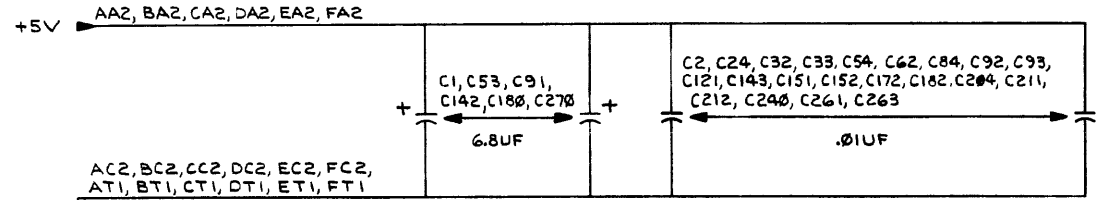
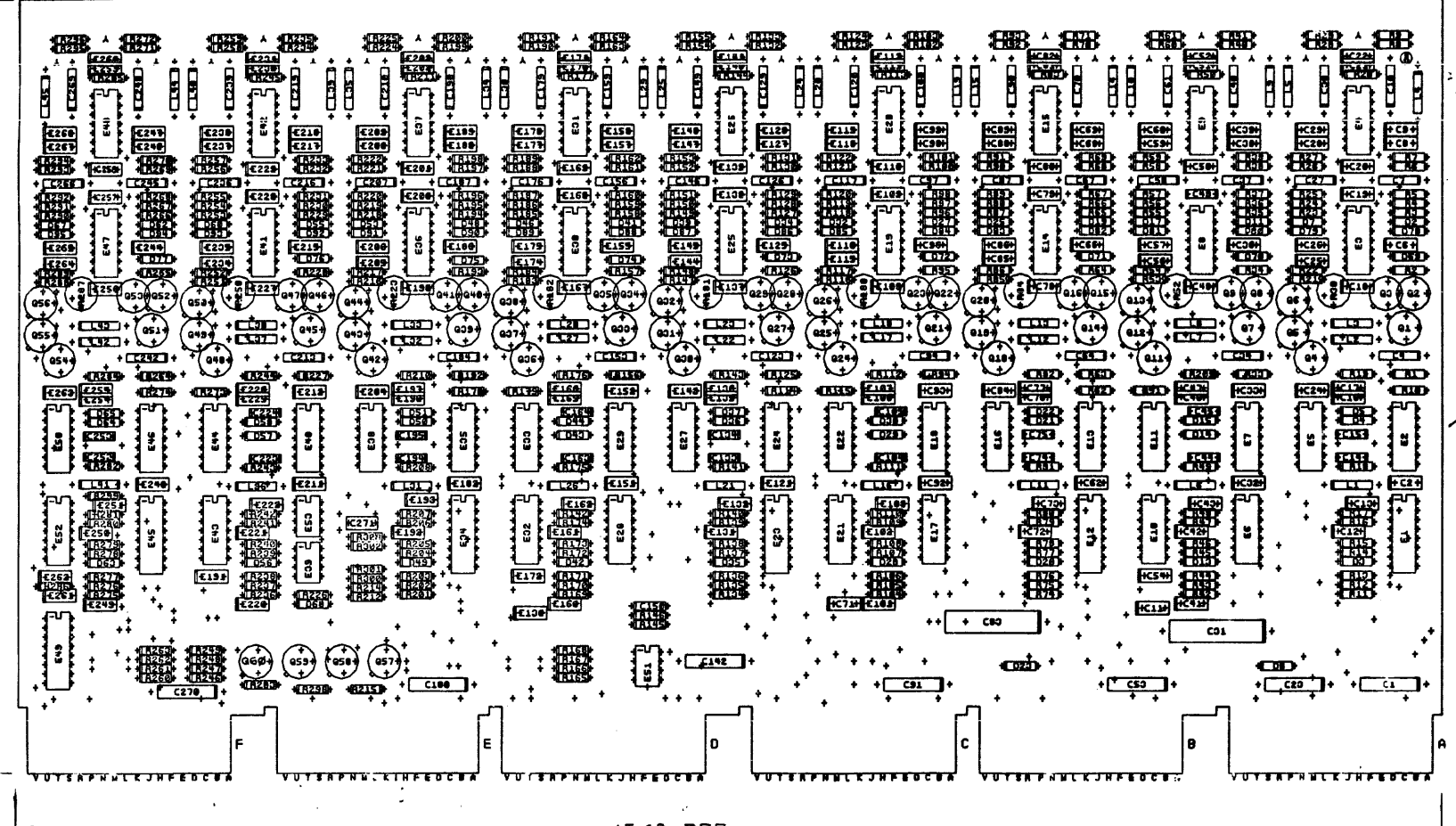

IC TYPE	GND	+5V
710	1	8
7476	8	16
74155	8	16

GND AND 5V ARE USUALLY PIN 7 AND 14 RESPECTIVELY. EXCEPTIONS ARE STATED ABOVE.

IC PIN LOCATIONS

W.D. 76
ARNOLD KORELITZ
Peter Corbett 7-6-76
G056-00008 L
W. SMITH
G056-00007 K
A. KORELITZ
G056-00006 J
A. KORELITZ
G056-00003 H
A. KORELITZ
G056-00002 D
G056-00000 2

QTY	REF DESIGNATION	DESCRIPTION	PART NO.	ITEM NO.										
FIRST USED ON OPTION MODEL														
TU16														
ETCH BOARD REV E														
PARTS LIST														
<table border="1"> <tr> <th>DRN.</th> <th>DATE</th> </tr> <tr> <td>CHKD</td> <td>3-13-74</td> </tr> <tr> <td>ENG</td> <td>2-14-74</td> </tr> <tr> <td>PROJ. ENG.</td> <td>2-14-74</td> </tr> <tr> <td>ENOD.</td> <td>2-14-74</td> </tr> </table>					DRN.	DATE	CHKD	3-13-74	ENG	2-14-74	PROJ. ENG.	2-14-74	ENOD.	2-14-74
DRN.	DATE													
CHKD	3-13-74													
ENG	2-14-74													
PROJ. ENG.	2-14-74													
ENOD.	2-14-74													
<table border="1"> <tr> <th>SIZE CODE</th> <th>NUMBER</th> <th>REV.</th> </tr> <tr> <td>DCS</td> <td>G056-0-1</td> <td>L</td> </tr> </table>					SIZE CODE	NUMBER	REV.	DCS	G056-0-1	L				
SIZE CODE	NUMBER	REV.												
DCS	G056-0-1	L												
SEMICONDUCTOR CONVERSION CHART														
SHEET 1 OF 7														

THIS DRAWING AND SPECIFICATIONS, HEREIN, ARE THE PROPERTY OF DIGITAL EQUIPMENT CORPORATION AND SHALL NOT BE REPRODUCED OR COPIED OR USED IN WHOLE OR IN PART AS THE BASIS FOR THE MANUFACTURE OR SALE OF ITEMS WITHOUT WRITTEN PERMISSION. COPYRIGHT © 1973, DIGITAL EQUIPMENT CORPORATION.

QTY	REF DESIGNATION	DESCRIPTION	PART NO.	ITEM NO.
REF		X-Y COORDINATE HOLE LOCATION	K-C0-G056-B-4	1
REF		ASSY-DRILLINGHOLE LAYOUT	D-AH-G056-B-5	2
REF		MODULE ECO HISTORY	B-MH-G056-B-6	3
1		ETCHED CIRCUIT BOARD	5010479	4
9	C20, C50, C80, C110, C139, C169, C201, C229, C258	CAP 680PF, 100V, 5% DM	1000026	5
6	C1, C53, C91, C142, C180, C270	CAP 6.8UF, 35V, 10% S.TANT	1005306	6
18	C14, C15, C44, C45, C74, C75, C104, C105, C133, C134, C163, C164, C194, C195, C223, C224, C252, C253	CAP .22UF, 50V, 10% CER	1010274	7
1	C23	CAP 10UF, 20V, 10% S.TANT	1004613	8
9	C11, C41, C71, C101, C130, C160, C181, C220, C249	CAP 820PF, 100V, 5%	1000027	9
9	C18, C49, C79, C109, C138, C168, C200, C228, C257	CAP 120PF, 100V 5% DM	1000018	10
9	C21, C51, C81, C111, C140, C170, C202, C230, C259	CAP 330PF, 100V, 5% DM	1000023	11
18	C10, C30, C40, C61, C70, C90, C100, C120, C129, C149, C158, C179, C190, C210, C219, C239, C248, C269	CAP 2.2UF, 20V, 10% S.TANT	1002627	12
9	C6, C25, C36, C56, C65, C85, C95, C115, C134, C144, C154, C174, C195, C205, C214, C234, C244, C264	CAP 82PF, 100V, 5% DM	1000015	13
18	C12, C13, C42, C43, C72, C73, C102, C103, C131, C132, C161, C162, C192, C193, C221, C222, C250, C251	CAP 470PF, 100V, 5% DM	1000024	14
74	C6, C8, C9, C16, C17, C26, C28, C29, C36, C38, C39, C46, C47, C57, C59, C60, C66, C68, C69, C76, C77, C86, C88, C89, C96, C98, C99, C126, C107, C116, C118, C119, C125, C127, C128, C135, C136, C145, C147, C148, C155, C157, C158, C165, C166, C175, C177, C178, C186, C188, C189, C196, C197, C206, C208, C209, C219, C217, C218, C225, C226, C235, C237, C238, C244, C246, C247, C254, C255, C262, C265, C267, C268, C181	CAP .47UF, 25V, 20% CER	1010279	15
2	C31, C83	CAP 22UF 35V, 20% S.TANT	1002433	16
9	C22, C52, C82, C112, C141, C171, C203, C231, C260	CAP .005UF, 100V, 20% DISC	1001765	17
9	C18, C48, C78, C108, C137, C167, C198, C227, C256	CAP 1000PF 250V, 20% DISC	1000043	18
27	C4, C7, C27, C34, C37, C58, C64, C67, C87, C84, C97, C117, C123, C146, C126, C153, C156, C176, C184, C187, C207, C213, C216, C236, C242, C245, C266	CAP 3.9UF 10V, 10% S.TANT	1000064	19
22	C2, C24, C32, C33, C54, C62, C84, C92, C93, C121, C143, C150, C151, C152, C172, C182, C204, C211, C212, C240, C261, C283	CAP .01UF 100V, 20% DISC	1001610-01	20
63	C2, C5, C7, C13, C14, C15, C17, C19, C20, C21, C22, C26, C27, C30, C34, C37, C39, C41, C44, C46, C48, C49, C51, C53, C55, C58, C60, C62, C65, C72, C74, C95	DIODE D664	1100114	21
1	D68	DIODE IN747A 3.6V 5%	1110672	23
2	D12, D23	DIODE IN758A	1100125	24
10	R23, R55, R87, R118, R149, R185, R218, R253, R290, R24	RES 910 $\frac{1}{2}$ W 5%	1305374	25
1	R145	RES 10 $\frac{1}{2}$ W 5%	1301317	26
2	R31, R72	RES 100 $\frac{1}{2}$W 5%	1301322	27
9	R21, R53, R85, R116, R147, R183, R216, R251, R288	RES 330 $\frac{1}{2}$ W 5%	1300295	28
1	R226	RES 47 $\frac{1}{2}$ W 5%	1300202	29

QTY	REF DESIGNATION	DESCRIPTION	PART NO.	ITEM NO.
26	R8, R28, R40, R60, R70, R92, R102, R123, R132, R154, R163, R190, R199, R224, R234, R256, R271, R276, R295, R215, R43, R75, R105, R135, R202, R237, R259, R272, R286, R296	RES 220 $\frac{1}{4}$ W 5%	1300271	30
18	R9, R22, R29, R41, R48, R61, R71, R75, R93, R103, R105, R124, R133, R138, R155, R164, R170, R191, R200, R202, R225, R235, R237, R259, R272, R286, R296	RES 470 $\frac{1}{2}$W 5%	1300316	31
11	R11, R42, R74, R104, R134, R169, R201, R236, R275, R286, R298	RES 680 $\frac{1}{2}$ W 5%	1301424	32
9	R25, R50, R85, R113, R144, R177, R211, R245, R285	RES 680, $\frac{1}{4}$ W, 5% NOMINAL		
74	R1, R6, R7, R15, R17, R26, R27, R33, R36, R39, R46, R48, R58, R59, R63, R69, R78, R80, R90, R91, R94, R100, R101, R108, R110, R121, R122, R125, R130, R131, R139, R140, R142, R152, R153, R156, R161, R162, R173, R189, R169, R192, R197, R198, R205, R207, R221, R222, R227, R232, R233, R240, R242, R246, R247, R248, R249, R256, R257, R260, R261, R262, R263, R264, R269, R270, R279, R281, R290, R294, R295, R302, R303	RES 1K $\frac{1}{2}$ W 5%	1300385	33
1	R283	RES 820, $\frac{1}{4}$, 5%	1301775	34
18	R18, R19, R49, R81, R82, R111, R112, R284, R141, R143, R175, R176, R244, R208, R209, R282, R210, R243	RES 120 $\frac{1}{2}$ W 5%	1300247	35
3	R166, R146, R168	RES 196 $\frac{1}{2}$ W 1%	1302956	36
11	R10, R51, R62, R114, R115, R165, R167, R178, R179, R273, R274	RES 4.7K $\frac{1}{2}$ W 5%	1300447	37
9	R22, R54, R86, R289, R117, R143, R184, R217, R252	RES 3.9K $\frac{1}{2}$ W 5%	1300444	38
9	R2, R34, R64, R126, R157, R193, R228, R265, R95	RES 4.0K $\frac{1}{4}$ W 1%	1305127	39
18	R14, R16, R45, R47, R77, R79, R107, R109, R137, R139, R172, R174, R204, R206, R239, R241, R278, R280	RES 150K $\frac{1}{2}$ W 5%	1302396	40
9	R13, R44, R76, R106, R136, R171, R205, R238, R277	RES 82 $\frac{1}{2}$ W 5%	1301477	41
9	R214	RES 820 OHM $\frac{1}{2}$W 5%	1305336	42
9	R25, R57, R89, R120, R151, R187, R220, R255, R292	RES 3.3K $\frac{1}{2}$ W 5%	1300439	43
9	R24, R56, R88, R119, R150, R186, R219, R254, R291	RES 15K $\frac{1}{2}$ W 5%	1300496	44
9	R30, R52, R84, R180, R181, R223, R250, R287, R182	POT 2K $\frac{1}{2}$ W 10%	1309150-07	45
1	R300	RES 47 $\frac{1}{2}$ W 5%	1300202	46
1	R214	RES 820 OHM $\frac{1}{2}$ W 5%	1501888	47
4	Q57, Q58, Q59, Q60	TRANSISTOR 6534D	1503409	48
2	Q18, Q17	TRANSISTOR 2N19	1501881	49
18	Q1, Q4, Q7, Q11, Q14, Q18, Q21, Q24, Q27, Q30, Q33, Q36, Q39, Q42, Q45, Q48, Q51, Q54	TRANSISTOR 6531B	1509338	52
36	Q2, Q3, Q5, Q6, Q8, Q9, Q12, Q13, Q15, Q16, Q19, Q20, Q22, Q23, Q25, Q26, Q28, Q29, Q31, Q32, Q34, Q35, Q37, Q38, Q40, Q41, Q43, Q44, Q46, Q47, Q49, Q50, Q52, Q53, Q55, Q56	TRANSISTOR 2N4250	1509142	5

QTY	REF DESIGNATION	DESCRIPTION	PART NO.	ITEM NO.
				52
4-5	L1, L8, L11, L16, L21, L26, L31, L38, L41, L2, L3, L4, L5, L7, L8, L9, L10, L12, L13, L14, L15, L17, L18, L19, L20, L22, L23, L24, L25, L27, L28, L29, L30, L32, L33, L34, L35, L37, L38, L39, L40, L42, L43, L44, L45	INDUCTOR 1000 UH	1602723	53
1	E48	I.C. 74158	1913233	54
2	E51, E53	I.C. 72741	1910298	55
18	E3, E4, E8, E9, E14, E15, E19, E20, E25, E26, E30, E31, E36, E37, E41, E42, E47, E48	I.C. 72733	1910644	56
5	E1, E12, E23, E34, E45	I.C. 7476	1905585	57
9	E2, E11, E13, E22, E24, E33, E35, E44, E46	I.C. 75107	1910268	58
9	E5, E7, E18, E18, E27, E29, E38, E40, E50	I.C. 710	1905620-01	59
5	E10, E21, E32, E43, E52	I.C. 7486	1910011	60
3	E6, E17, E28	I.C. 7404	1939686	61
12		EYELET	9006732	62
27		SPLIT LUG	9006735	63
1		HANDLE, HEX	1210711-2	64
				65
1		READ CABLE	7010057-C-0	66
1		CABLE READ BOARD	7009920-0-0	67
9	R20, R50, R83, R113, R144, R177, R211, R245, R285	RES 470 $\frac{1}{4}$ W 5% (HIGH GAIN) OR RES 820 $\frac{1}{4}$ W 5% (LOW GAIN) NOTE: TO BE CHANGED AT FINAL SYSTEM TEST IF NECESSARY	1300316 1301775	68
				69
				70
9	C11, C41, C71, C101, C130, C160, C191, C220, C249	CAP 1500 PF	1000054	71
		NOTE: GAIN ADJUST REFER TO ITEM #20 RES 470 (MAX GAIN) RES 680 RES 820 RES 1.2K (NOMINAL) RES 18K (MIN GAIN)		
1	D8	DIODE D777	1103041	72
18	R300-317	RES 270 $\frac{1}{4}$ W 5%	1301972	73
9	D69-D77	ZENER DIODE IN942 11.7V	11-03345	74
9	R5, R37, R67, R98, R160, R195, R267, R231, R129	RES 3.16K $\frac{1}{4}$ W 1%	13-3045	75
	R2	RES 511 $\frac{1}{4}$ W 1%	1302411	76
9	R4, R36, R66, R97, R159, R195, R267, R230, R128	RES 14.7K $\frac{1}{4}$ W 1%	1302941	77
9	R3, R35, R65, R96, R158, R154, R268, R229, R127	RES 909 $\frac{1}{8}$ W 1%	1302695	78
1	R301	RES 15K $\frac{1}{4}$ W 5%	1300391	79
1	C271	CAP .047 MFD, POLYCARB	1009433	80
1	E39	I.C. 75452	1910645	81

CHK	CHANGE NO	REV	TITLE	SIZE CODE	NUMBER
			READ AMP (RA2)	D CS	G056-0-1
			SCALE	SHEET 2 OF 7	DIST.

THIS DRAWING AND SPECIFICATIONS HEREIN ARE THE PROPERTY OF DIGITAL EQUIPMENT CORPORATION AND SHALL NOT BE REPRODUCED OR COPIED OR USED IN WHOLE OR IN PART AS THE BASIS FOR THE MANUFACTURE OR SALE OF ITEMS WITHOUT WRITTEN PERMISSION. COPYRIGHT © 1973, DIGITAL EQUIPMENT CORPORATION.

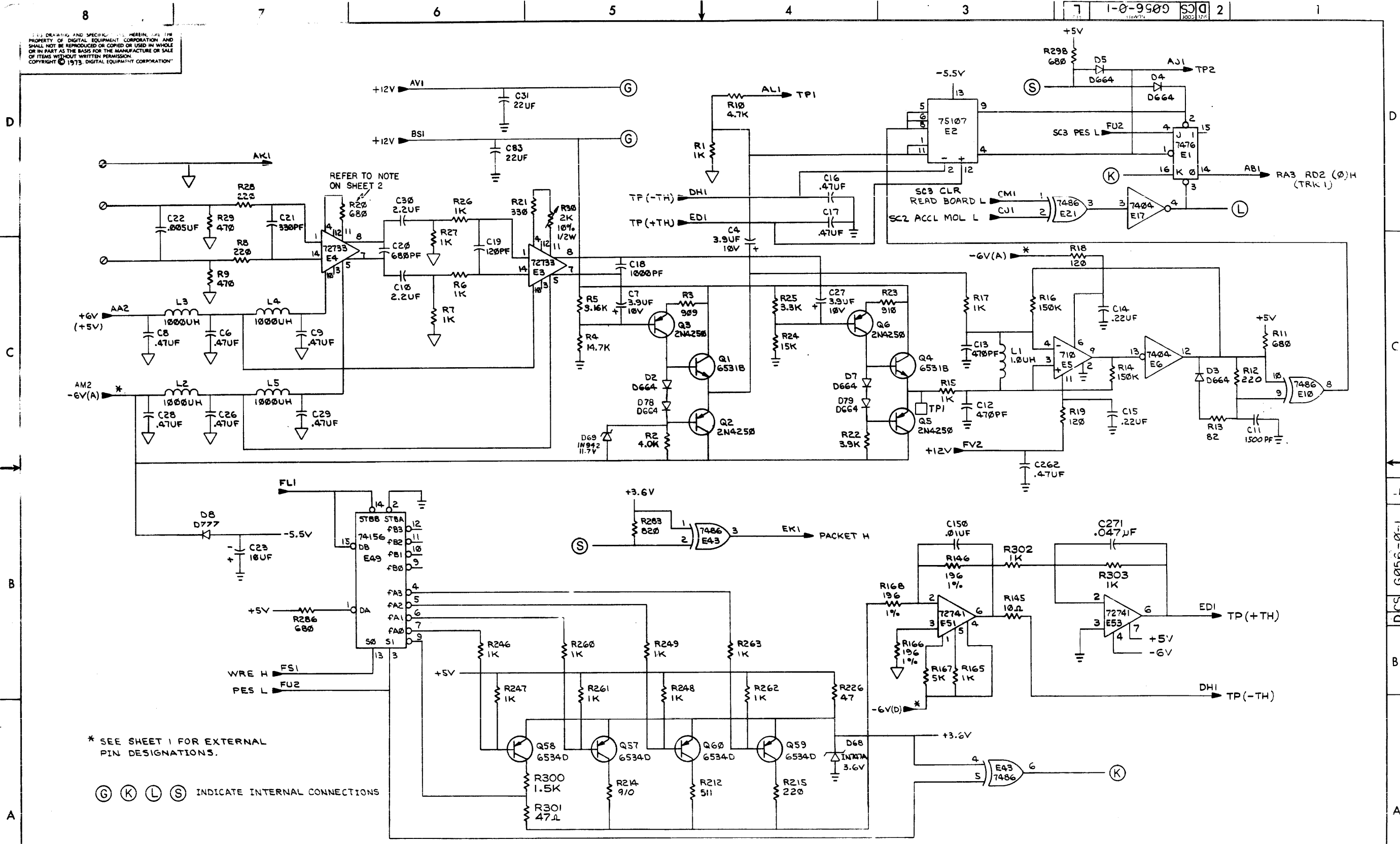

* SEE SHEET 1 FOR EXTERNAL PIN DESIGNATIONS.

ⓐ Ⓚ Ⓛ Ⓢ INDICATE INTERNAL CONNECTIONS

REVISIONS		
CHK	CHANGE NO	REV

TITLE	READ AMP (RA3)	SIZE/CODE	D CS	NUMBER	G056-0-1	REV.	L
SCALE	+	SHEET	3	OF	7	DIST.	

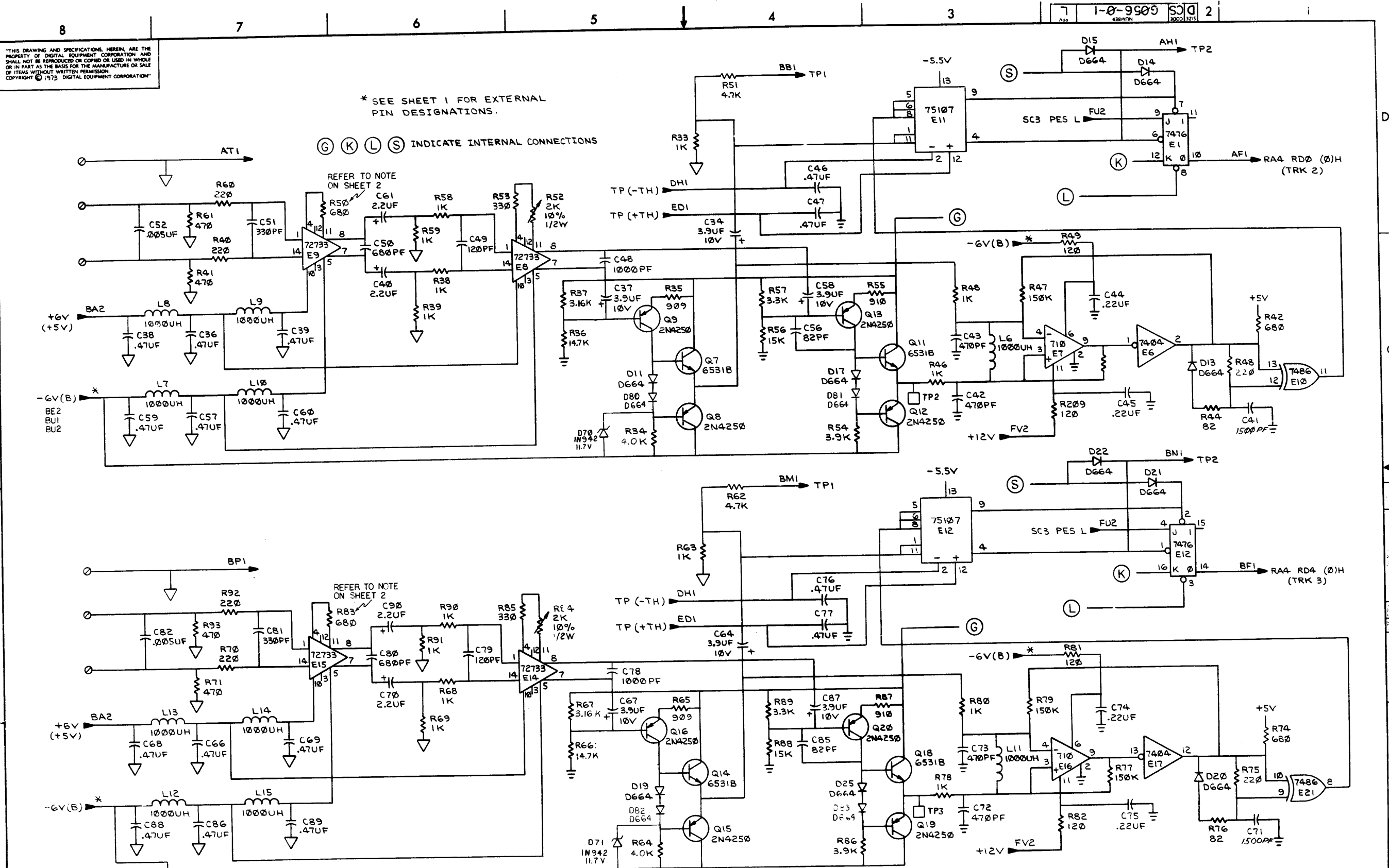

REVISIONS			TITLE		SIZE CODE	NUMBER	REV
CHK	CHANGE NO	REV	READ AMP (RA4)		D CS	G056-0-1	L
			SCALE	SHEET 4 OF 7	DIST.		

DCS G056-0-1

PROPERTY OF DIGITAL EQUIPMENT CORPORATION. IT SHALL NOT BE REPRODUCED OR COPIED OR USED IN WHOLE OR IN PART AS THE BASIS FOR THE MANUFACTURE OR SALE OF ITEMS WITHOUT WRITTEN PERMISSION. COPYRIGHT © 1973, DIGITAL EQUIPMENT CORPORATION.

*SEE SHEET 1 FOR EXTERNAL PIN DESIGNATIONS.
 (G) (K) (L) (S) INDICATE INTERNAL CONNECTION

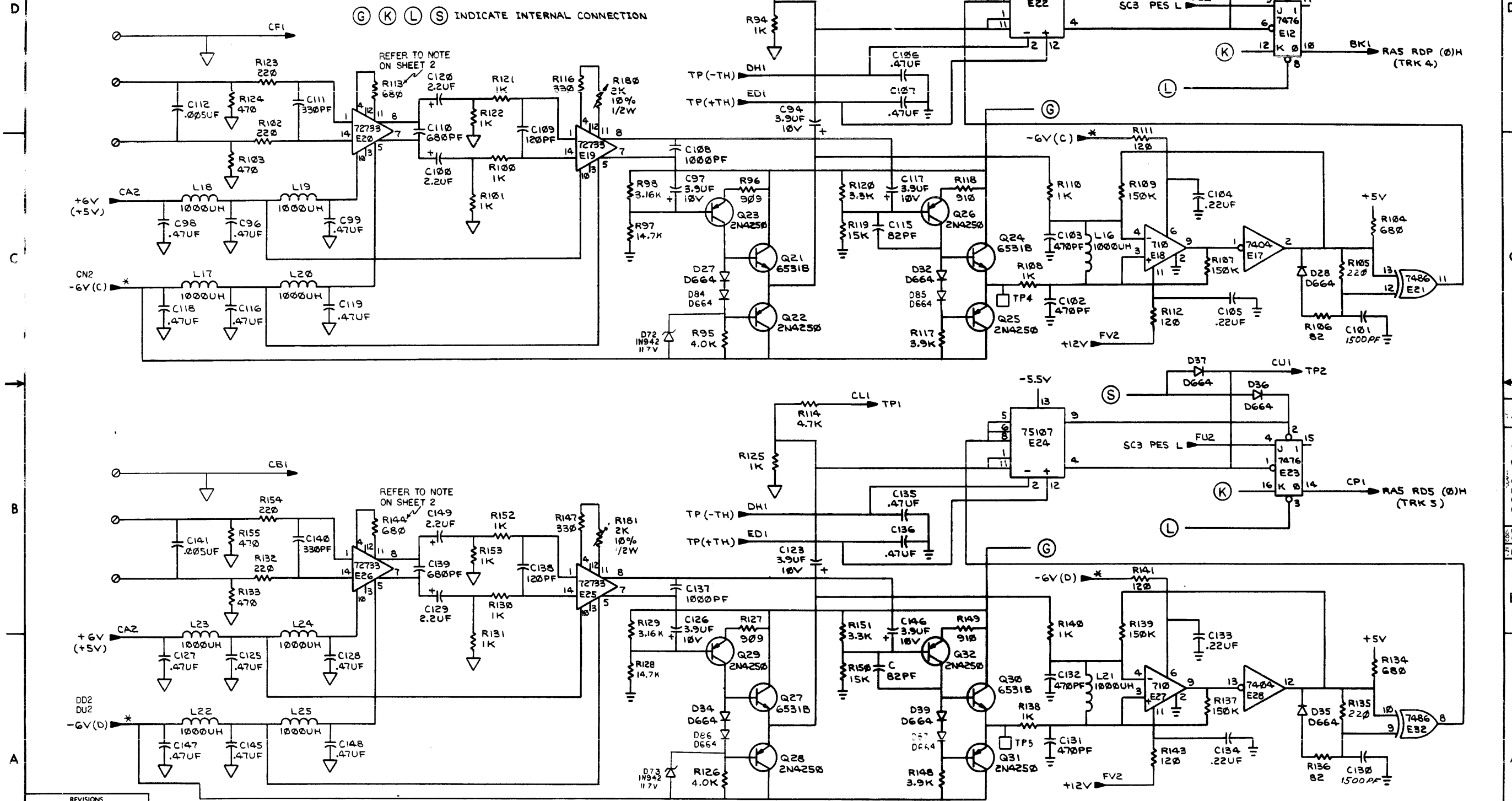

REVISIONS		
CHK	CHANGE NO	REV

TITLE	READ AMP (RA5)	SIZE CODE	D CS	NUMBER	G056-0-1	REV.	L
SCALE	+	SHEET	5	OF	7	DIST.	

THIS DRAWING AND SPECIFICATIONS, HEREIN, ARE THE PROPERTY OF DIGITAL EQUIPMENT CORPORATION AND SHALL NOT BE REPRODUCED OR COPIED OR USED IN WHOLE OR IN PART AS THE BASIS FOR THE MANUFACTURE OR SALE OF ITEMS WITHOUT WRITTEN PERMISSION. COPYRIGHT © 1973, DIGITAL EQUIPMENT CORPORATION.

* SEE SHEET 1 FOR EXTERNAL PIN DESIGNATIONS.

(G) (K) (L) (S) INDICATE INTERNAL CONNECTIONS

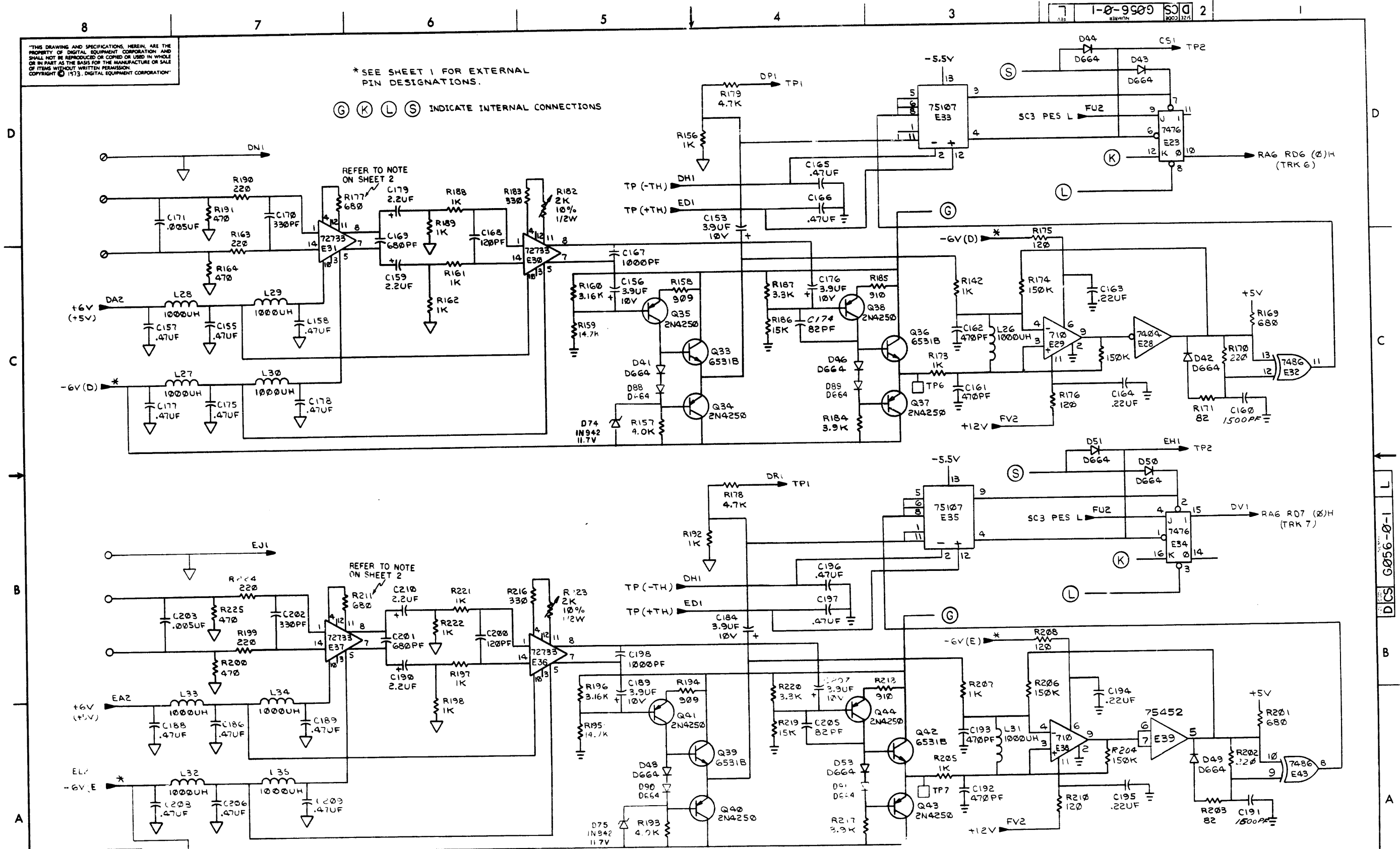

REVISIONS		
CHK	CHANGE NO	REV

TITLE	READ AMP (RA6)	SIZE/CODE	D CS	NUMBER	G056-0-1	REV	L
SCALE		SHEET	6	OF	7	DIST.	

THIS DRAWING AND SPECIFICATIONS HEREIN ARE THE PROPERTY OF DIGITAL EQUIPMENT CORPORATION AND SHALL NOT BE REPRODUCED OR COPIED OR USED IN WHOLE OR IN PART AS THE BASIS FOR THE MANUFACTURE OR SALE OF ITEMS WITHOUT WRITTEN PERMISSION. COPYRIGHT © 1975, DIGITAL EQUIPMENT CORPORATION.

* SEE SHEET 1 FOR EXTERNAL PIN DESIGNATIONS.

(G) (K) (L) (S) INDICATE INTERNAL CONNECTIONS

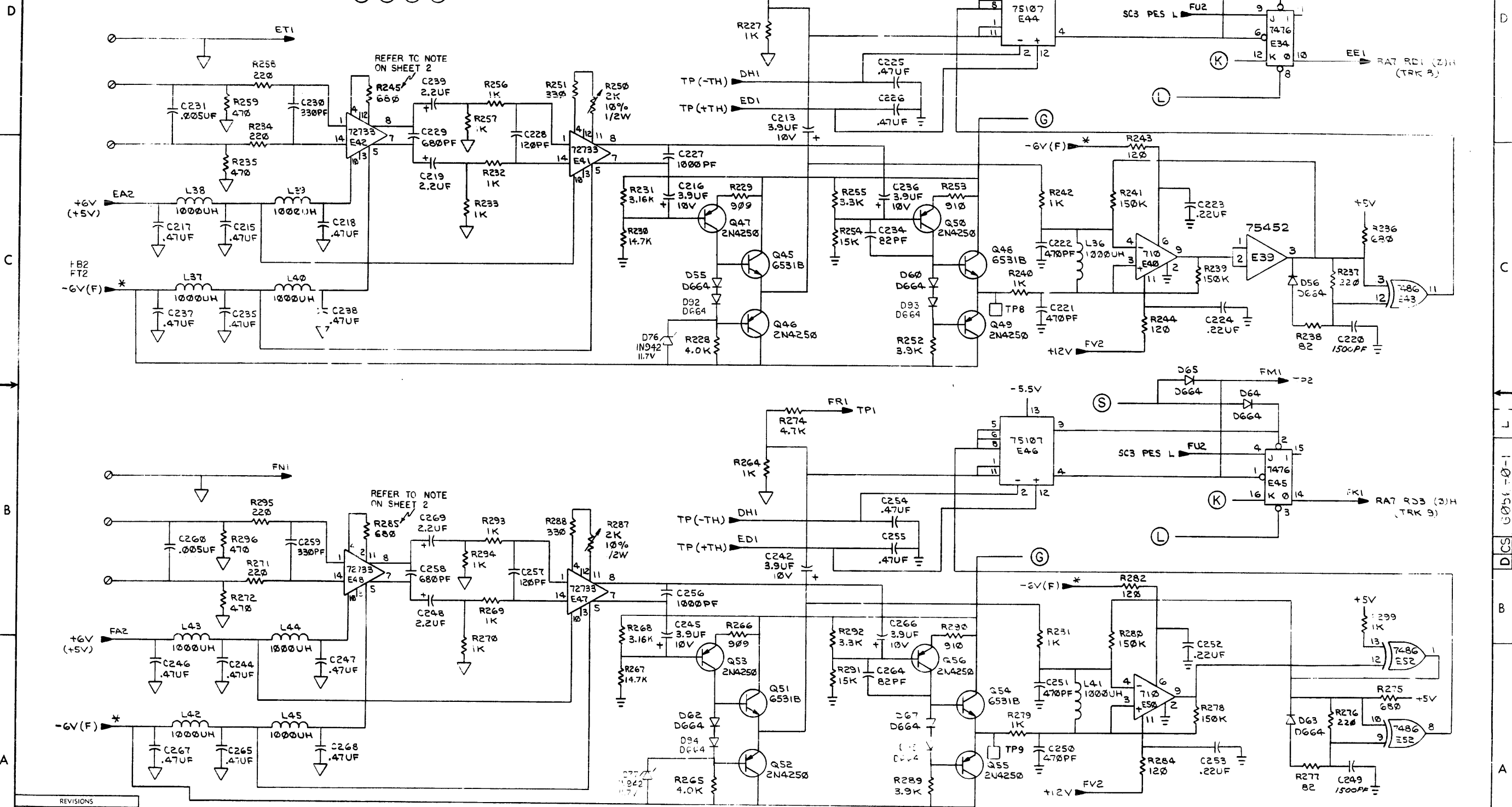

REVISIONS		
CHK	CHANGE NO	REV

TITLE	READ AMP (RA7)	SIZE CODE	D CS	NUMBER	G056-0-1
SCALE		SHEET	7	OF	7
DIST.					

THIS DRAWING AND SPECIFICATIONS HEREIN ARE THE PROPERTY OF DIGITAL EQUIPMENT CORPORATION AND SHALL NOT BE REPRODUCED OR COPIED OR USED IN WHOLE OR IN PART AS THE BASIS FOR THE MANUFACTURE OR SALE OF ITEMS WITHOUT WRITTEN PERMISSION. COPYRIGHT © 1973 DIGITAL EQUIPMENT CORPORATION

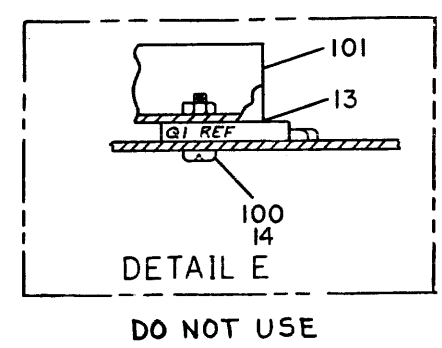
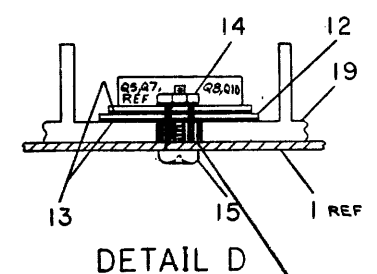
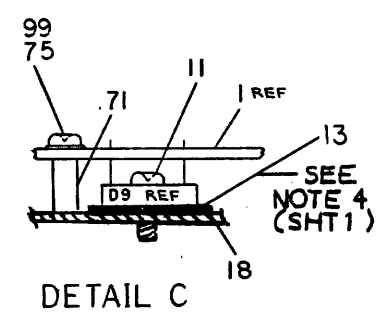
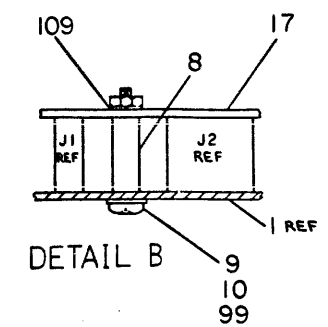
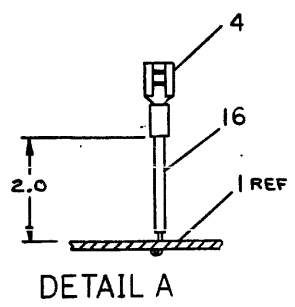
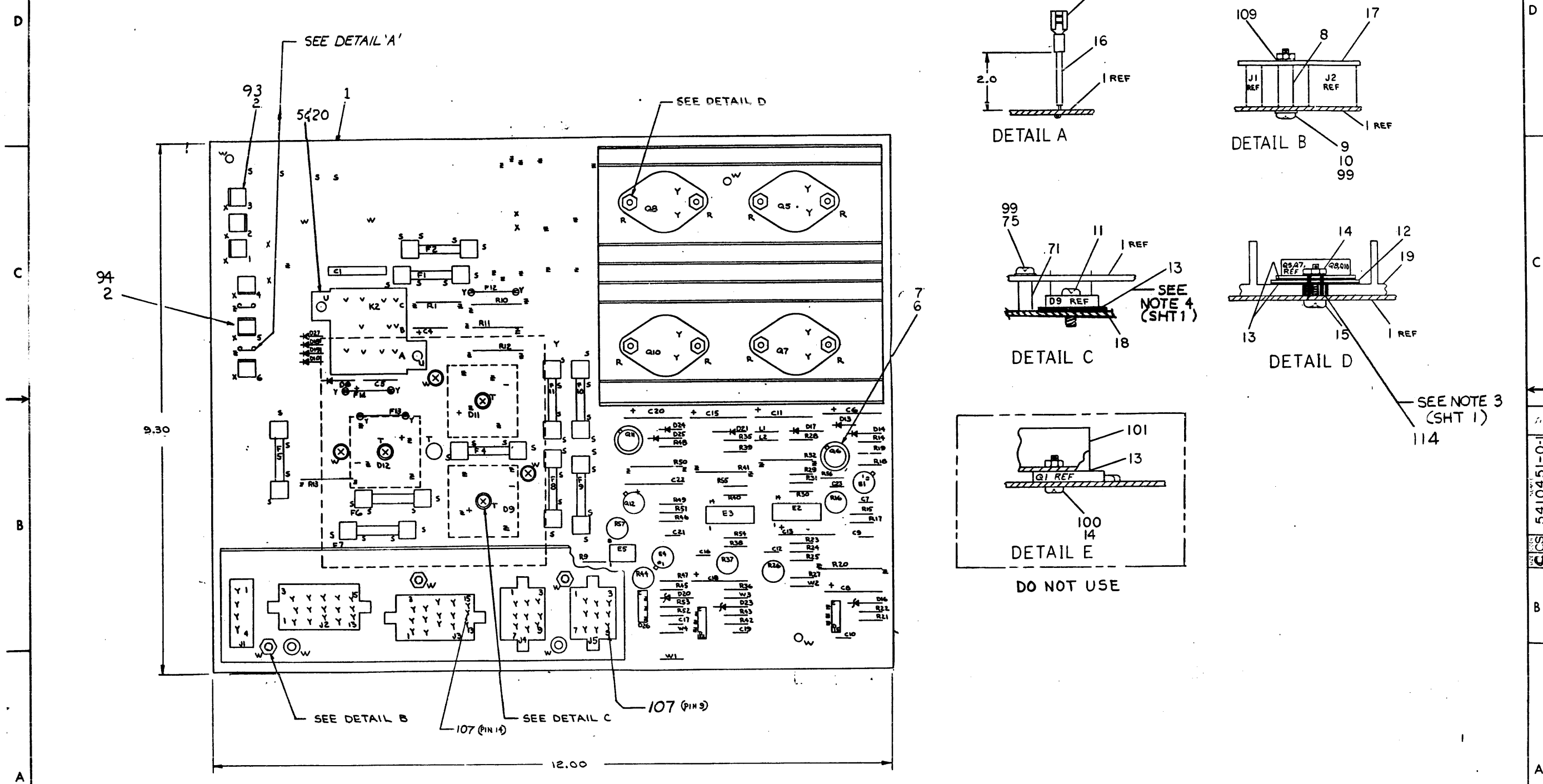

REVISIONS		
CHK	CHANGE NO	REV

TITLE	TUI6 POWER SUPPLY	SIZE CODE	C CS	NUMBER	5410451-0-1	REV.	S
SCALE		SHEET	2	OF	4	DIST.	

THIS DRAWING AND SPECIFICATIONS HEREIN ARE THE PROPERTY OF DIGITAL EQUIPMENT CORPORATION AND SHALL NOT BE REPRODUCED OR COPIED OR USED IN WHOLE OR IN PART AS THE BASIS FOR THE MANUFACTURE OR SALE OF ITEMS WITHOUT WRITTEN PERMISSION. COPYRIGHT © 1975, DIGITAL EQUIPMENT CORPORATION

ALL COMPONENTS ABOVE DOTTED LINE ARE NOT ON THE BOARD

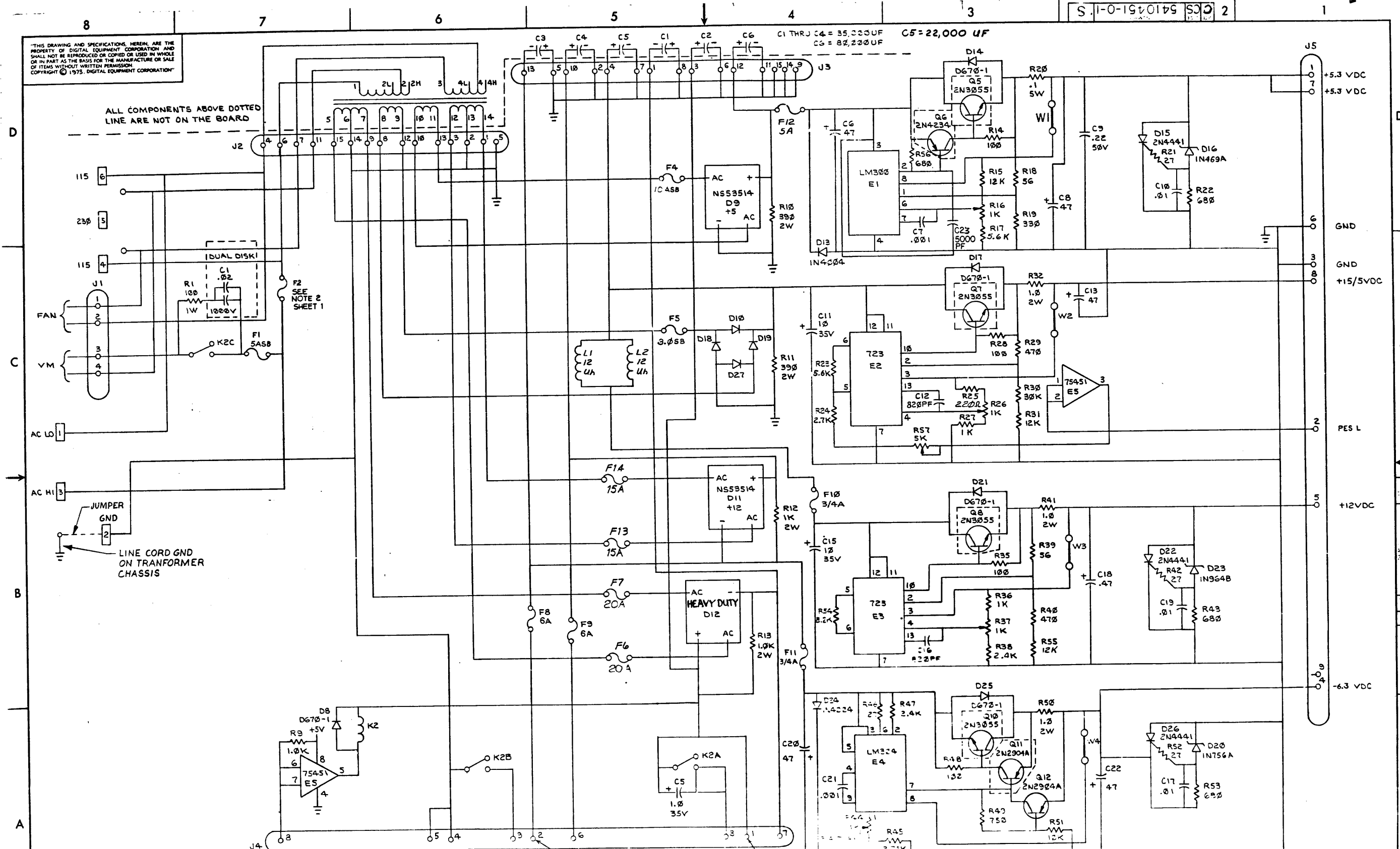

REV	NO	DATE	BY	CHK

"THIS DRAWING AND SPECIFICATIONS HEREIN ARE THE PROPERTY OF DIGITAL EQUIPMENT CORPORATION AND SHALL NOT BE REPRODUCED OR TRANSMITTED IN ANY FORM OR BY ANY MEANS, ELECTRONIC OR MECHANICAL, INCLUDING PHOTOCOPYING, RECORDING, OR BY ANY INFORMATION STORAGE AND RETRIEVAL SYSTEM, WITHOUT WRITTEN PERMISSION OF DIGITAL EQUIPMENT CORPORATION."
 COPYRIGHT © 1976 DIGITAL EQUIPMENT CORPORATION

VOLTAGE RANGE 50-60CPS	TRANSFORMER PRIMARY TAPS
95 to 105 190 to 210	1 and 2L; 3 and 4L
105 to 120 210 to 240	1 and 2; 3 and 4
120 to 132 240 to 264	1 and 2H; 3 and 4H

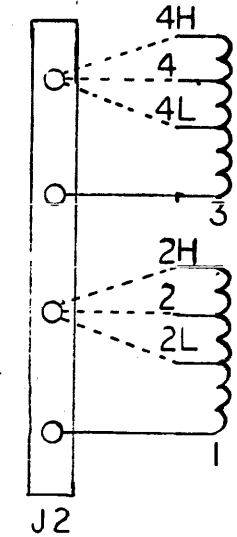

VOLTAGE (NOMINAL) INPUT	W1 CONN	W2 CONN
115V 50-60 CPS	4	6
230V 50-60 CPS	5A	5B

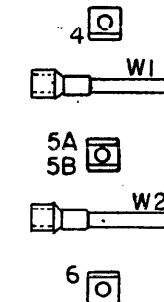

REV.	CHANGE NO.

FIRST USED ON OPTION/MODEL	QTY.	DESCRIPTION	PART NO.	ITEM NO.
PARTS LIST				
DIMENSIONAL TOLERANCE DIMENSIONS ARE MILLIMETERS / INCHES UNLESS OTHERWISE SPECIFIED		DRN. H. DANALJIAN DATE 11-9-73		
MILLIMETERS X,XX ±0.10 X,X ±0.5 X ±2	INCHES .XXX ±.005 .XX ±.02 .X ±.1	ENG. A. KORELITZ DATE 1-14-74		
THIRD ANGLE PROJECTION 		PROJ. ENG. A. KORELITZ DATE 1-14-74		
REMOVE BURRS AND BREAK SHARP CORNERS SURFACE QUALITY ✓		PROD. R. GOGUEN DATE 1-14-75		
MATERIAL FINISH		NEXT HIGHER ASSY.	TITLE TU16 POWER SUPPLY	
SCALE SHEET 4 OF 4		SIZE CODE C CS	NUMBER 5410451-0-1	REV. S

REV. S
 NUMBER 5410451-0-1
 SIZE CODE C CS

PROPERTY OF DIGITAL EQUIPMENT CORPORATION AND SHALL NOT BE REPRODUCED OR COPIED OR USED IN WHOLE OR IN PART AS THE BASIS FOR THE MANUFACTURE OR SALE OF ITEMS WITHOUT WRITTEN PERMISSION. COPYRIGHT © 1975, DIGITAL EQUIPMENT CORPORATION.

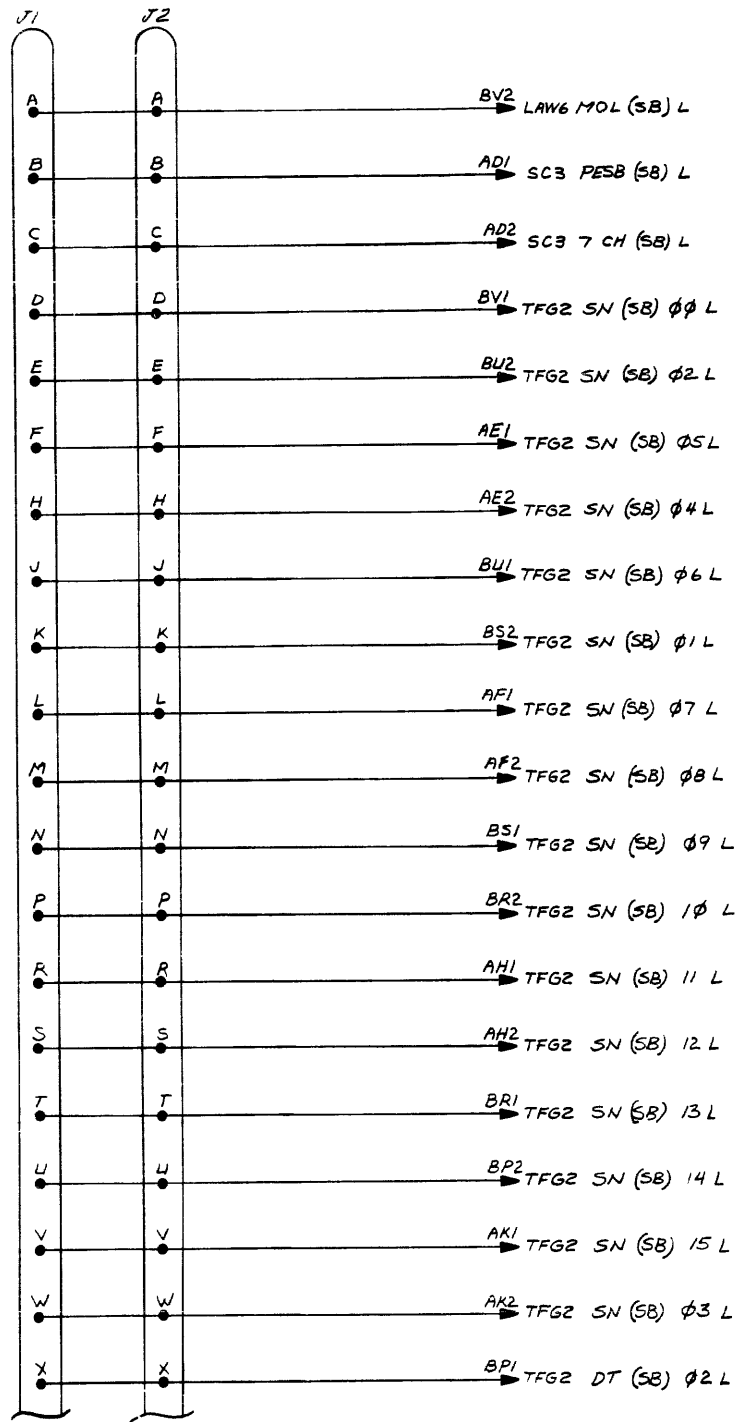

NOTE: ALL SIGNALS DESIGNATED "SBUS" ORIGINATE IN TM02.

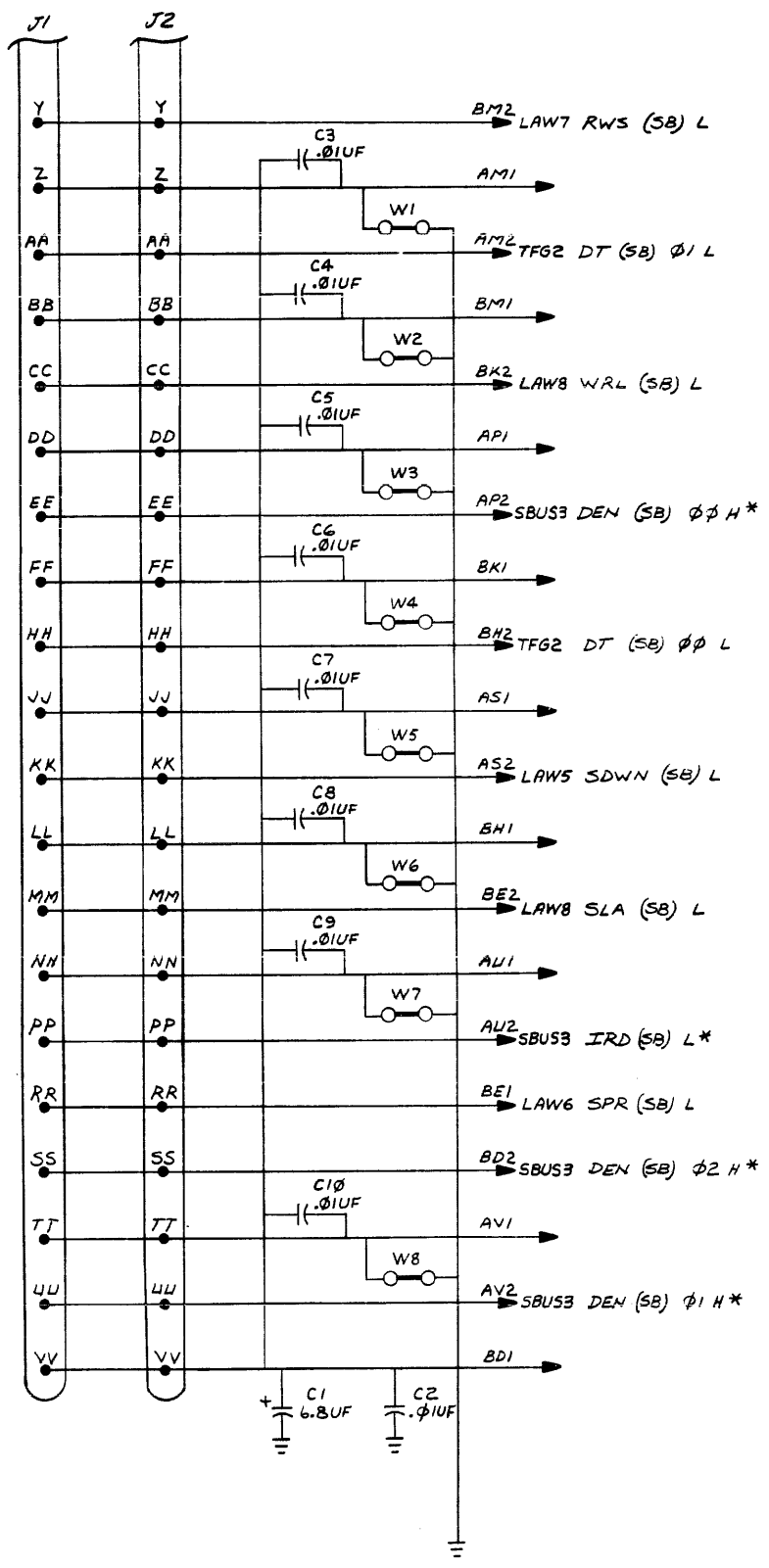

REVISIONS		
CHK	CHANGE NO.	REV.

TITLE GEN PURPOSE CARD (E & F)		SIZE CODE DCS	NUMBER M9001-YA-1	REV. C
SCALE		SHEET 2 OF 2		DIST.

DIGITAL EQUIPMENT CORPORATION
 M9001-YA-1 C

THIS DRAWING AND SPECIFICATIONS HEREIN ARE THE PROPERTY OF DIGITAL EQUIPMENT CORPORATION AND SHALL NOT BE REPRODUCED OR COPIED OR USED IN WHOLE OR IN PART AS THE BASIS FOR THE MANUFACTURE OR SALE OF ITEMS WITHOUT WRITTEN PERMISSION. COPYRIGHT © 1974, DIGITAL EQUIPMENT CORPORATION.

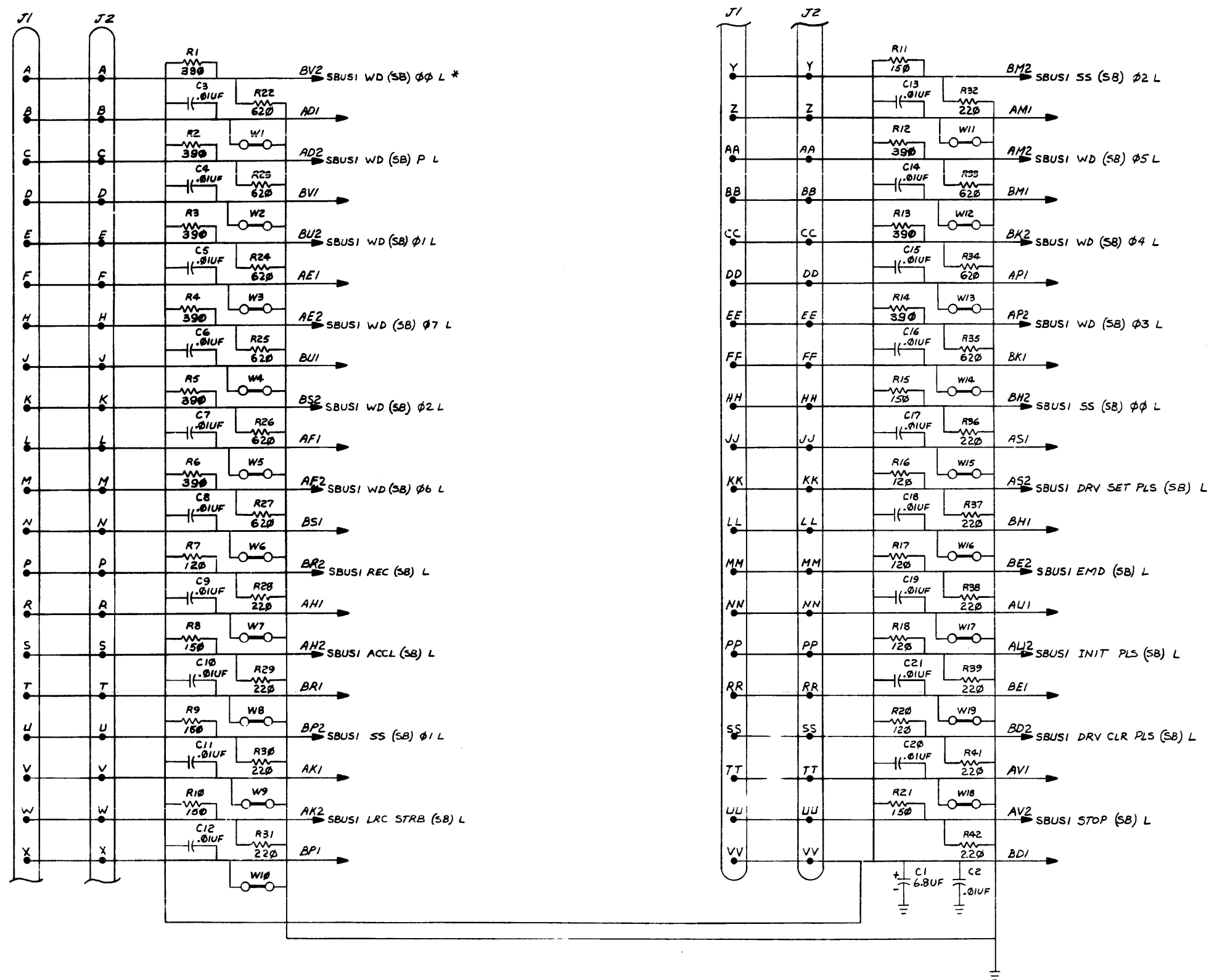

* NOTE: ALL SIGNALS ORIGINATE IN TM02

REVISIONS		
CHK	CHANGE NO	REV

TITLE	GEN PURPOSE CARD (A & B)	SIZE CODE	D CS	NUMBER	M9001-YB-1	REV.	C
SCALE	+	SHEET	2	OF	2	DIST.	

THIS DRAWING AND SPECIFICATIONS HEREIN ARE THE PROPERTY OF DIGITAL EQUIPMENT CORPORATION AND SHALL NOT BE REPRODUCED OR COPIED OR USED IN WHOLE OR IN PART AS THE BASIS FOR THE MANUFACTURE OR SALE OF ITEMS WITHOUT WRITTEN PERMISSION. COPYRIGHT © 1975, DIGITAL EQUIPMENT CORPORATION

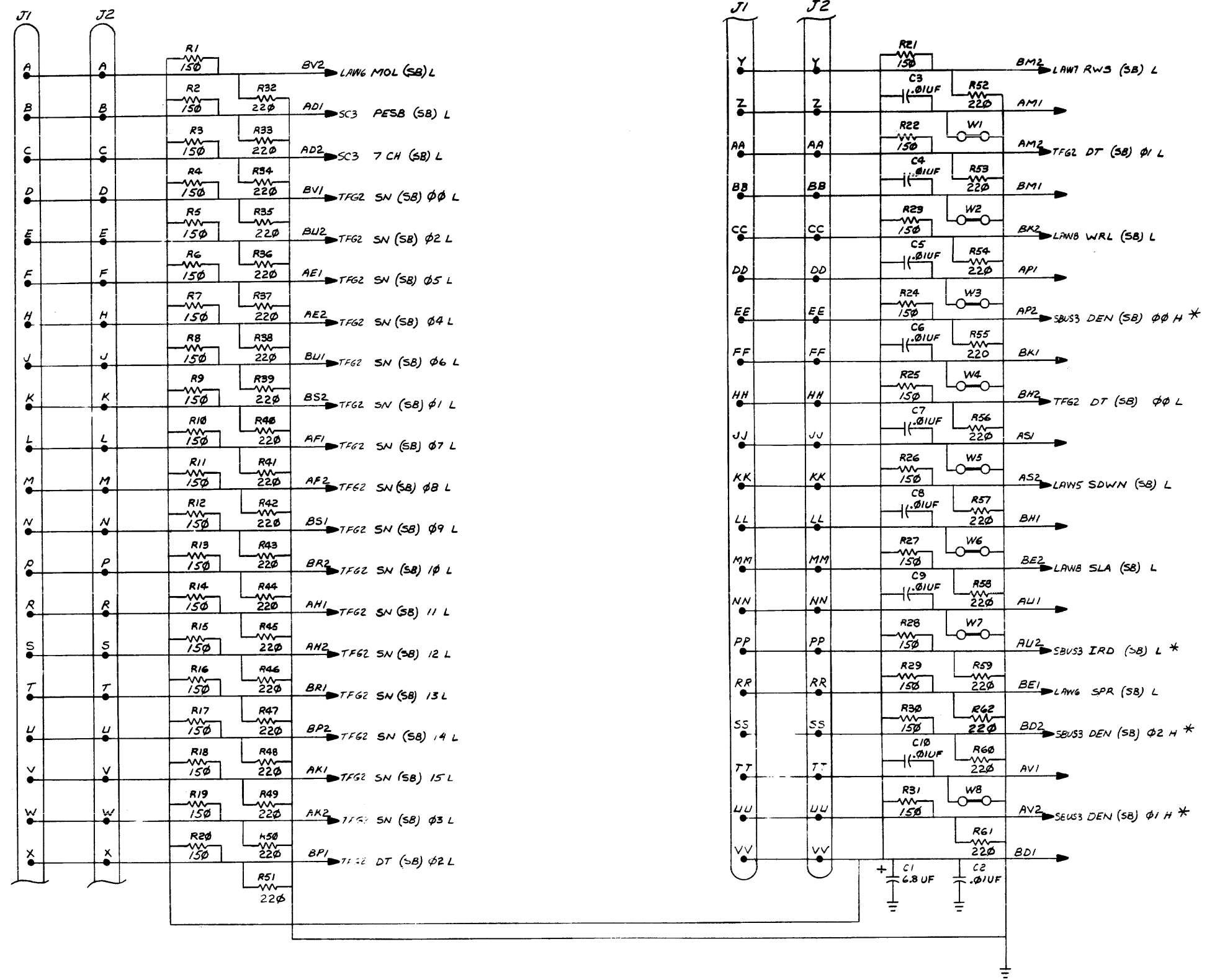

* NOTE: ALL SIGNALS DESIGNATED "SBUS" ORIGINATE IN TM02.

REVISIONS		
CHK	CHANGE NO.	REV.

TITLE	GEN PURPOSE CARD (E & F)	SIZE CODE	D CS	NUMBER	M9001-YC-1	REV.	C
SCALE	+	SHEET	2	OF	2	DIST.	

"THIS DRAWING AND SPECIFICATIONS HEREIN ARE THE PROPERTY OF DIGITAL EQUIPMENT CORPORATION AND SHALL NOT BE REPRODUCED OR COPIED OR USED IN WHOLE OR IN PART AS THE BASIS FOR THE MANUFACTURE OR SALE OF ITEMS WITHOUT WRITTEN PERMISSION. COPYRIGHT © 1974, DIGITAL EQUIPMENT CORPORATION"

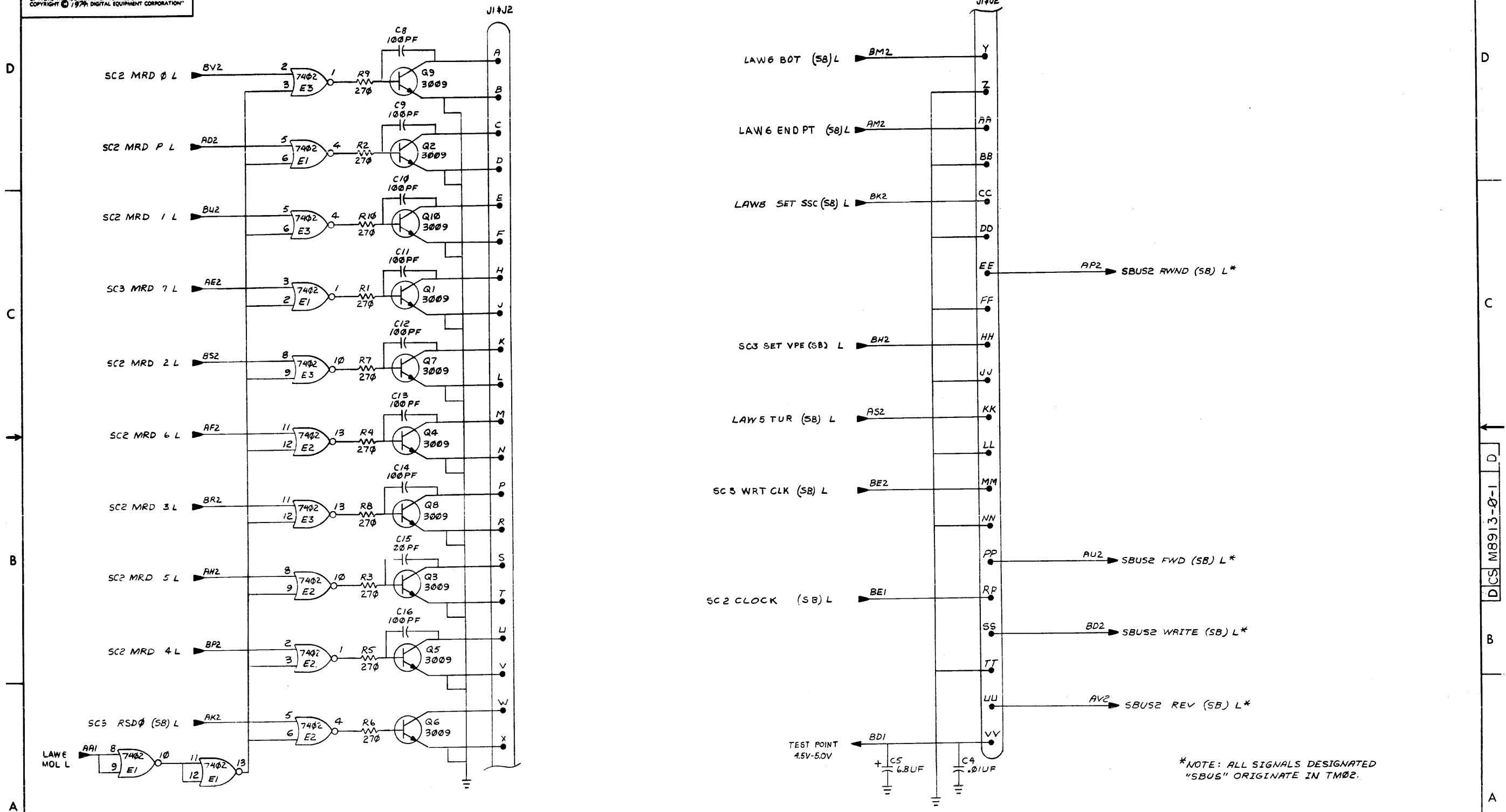

REVISIONS		
CHK	CHANGE NO	REV

TITLE	SBUS2 (SLOT C/P)	SIZE CODE	D	NUMBER	M8913-0-1	REV	1
SCALE	+	SHEET	2	OF	2	DIST	

THIS DRAWING AND SPECIFICATIONS HEREIN ARE THE PROPERTY OF DIGITAL EQUIPMENT CORPORATION AND SHALL NOT BE REPRODUCED OR COPIED OR USED IN WHOLE OR IN PART AS THE BASIS FOR THE MANUFACTURE OR SALE OF ITEMS WITHOUT WRITTEN PERMISSION. COPYRIGHT © 1974, DIGITAL EQUIPMENT CORPORATION

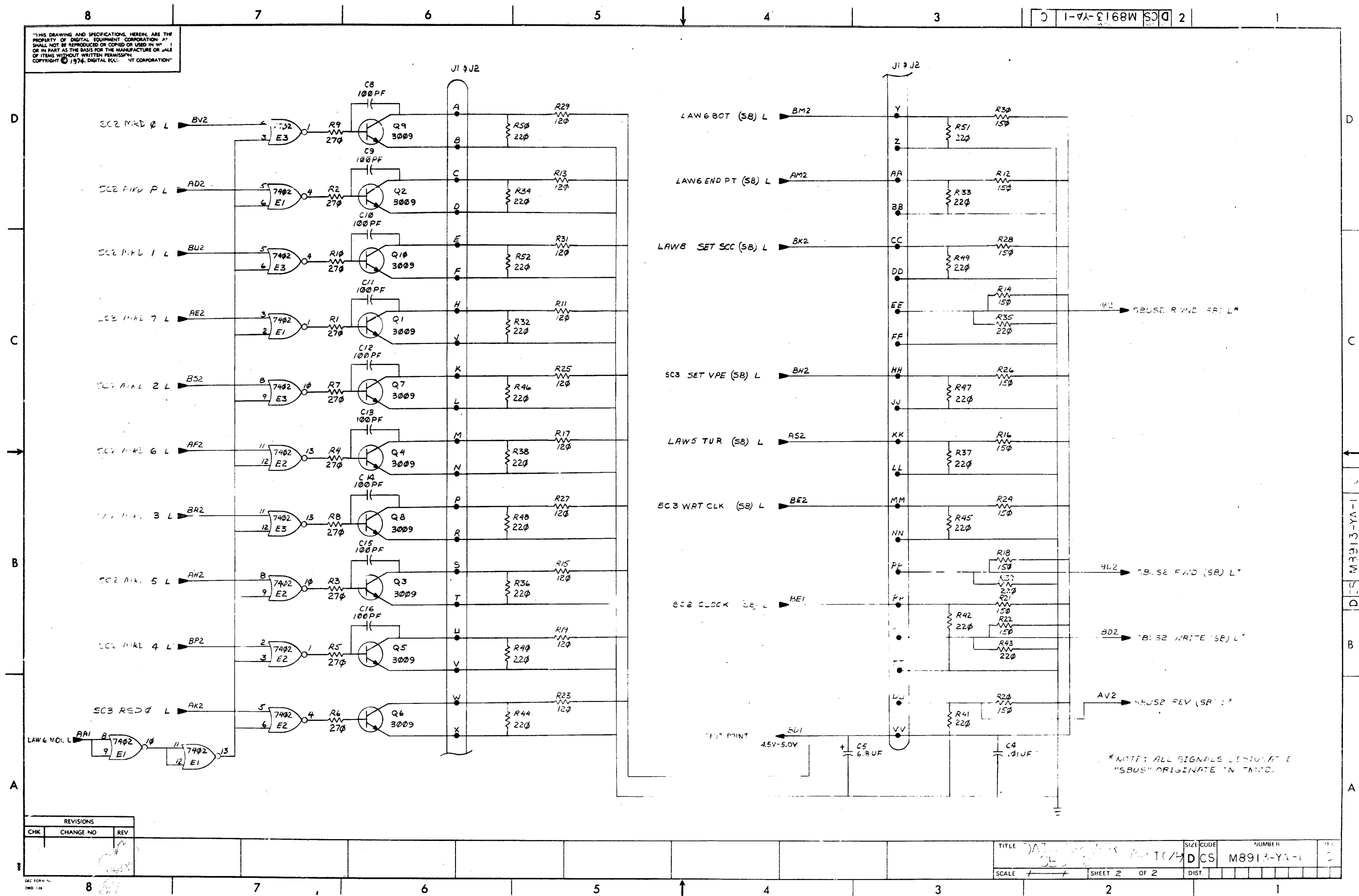

*NOTE: ALL SIGNALS DESIGNATED "SBUS" ORIGINATE IN TAND.

REVISIONS		
CHK	CHANGE NO	REV

TITLE	DATE	SIZE	CODE	NUMBER
DAT		D	CS	M8913-YA-1
SCALE	SHEET 2 OF 2	DIST.		

"THIS DRAWING AND SPECIFICATIONS, HEREIN, ARE THE PROPERTY OF DIGITAL EQUIPMENT CORPORATION, AND SHALL NOT BE REPRODUCED OR COPIED OR USED IN WHOLE OR IN PART AS THE BASIS FOR THE MANUFACTURE OR SALE OF ITEMS WITHOUT WRITTEN PERMISSION. COPYRIGHT © 1974, DIGITAL EQUIPMENT CORPORATION."

D

C

B

A

D

C

B

A

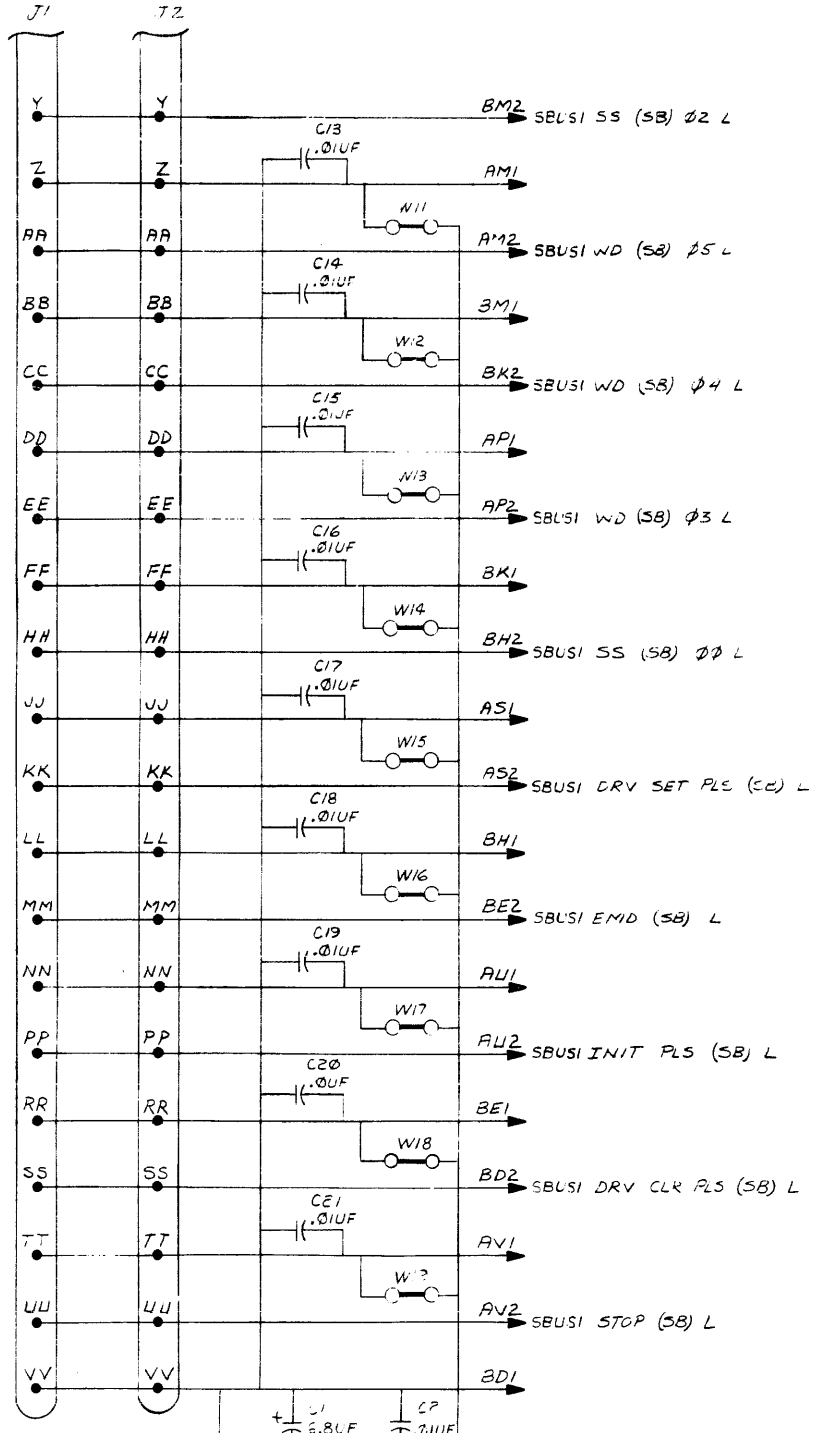
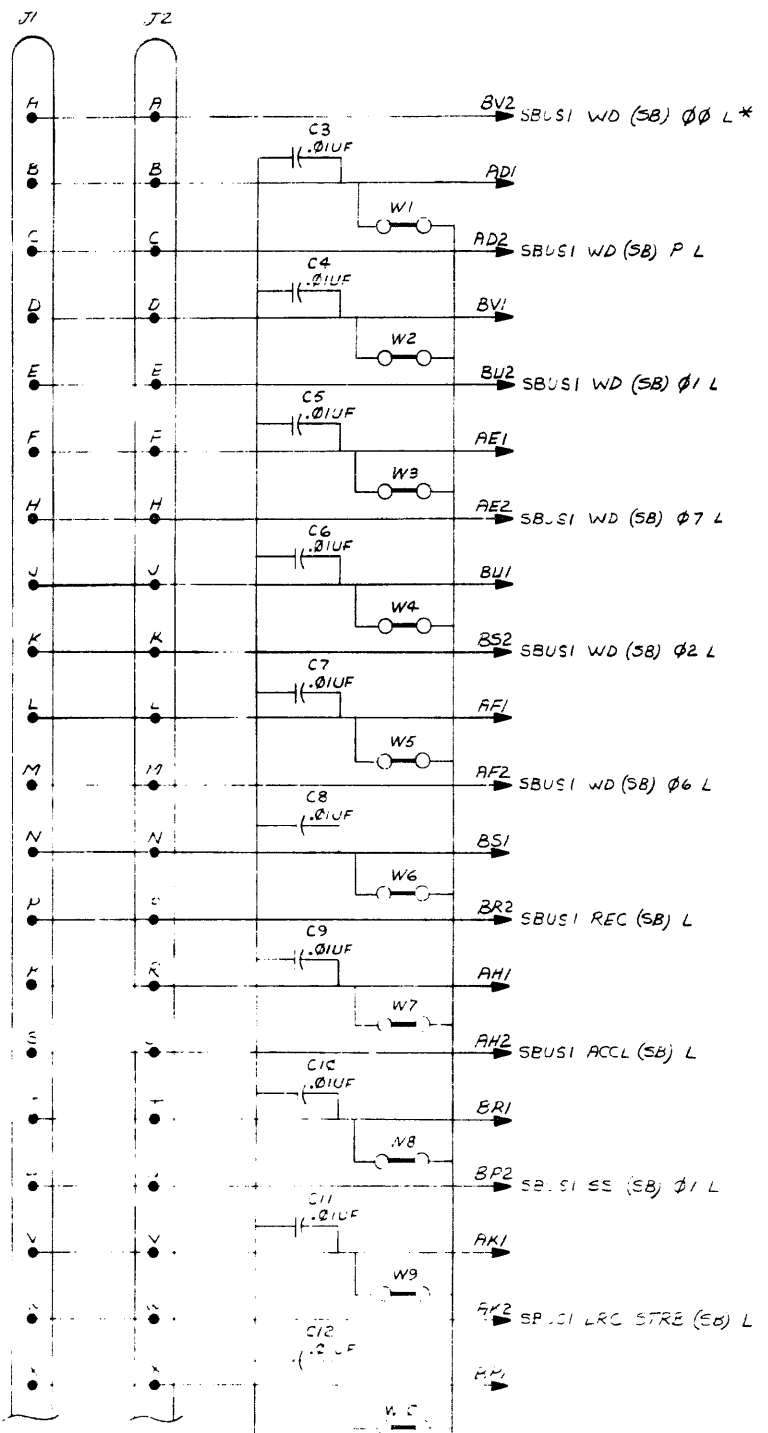

* NOTE: ALL SIGNALS ORIGINATE IN TMSO.

REVISIONS		
CHK	CHANGE NO.	REV

TITLE	GEN PURPOSE CARD (A & B)	SIZE CODE	D CS	NUMBER	M9001-0-1	REV	C
SCALE	+	SHEET	2	OF	2	DIST.	

"THIS DRAWING AND SPECIFICATIONS HEREIN ARE THE PROPERTY OF DIGITAL EQUIPMENT CORPORATION AND SHALL NOT BE REPRODUCED OR COPIED OR USED IN WHOLE OR IN PART AS THE BASIS FOR THE MANUFACTURE OR SALE OF ITEMS WITHOUT WRITTEN PERMISSION. COPYRIGHT © 1974, DIGITAL EQUIPMENT CORPORATION"

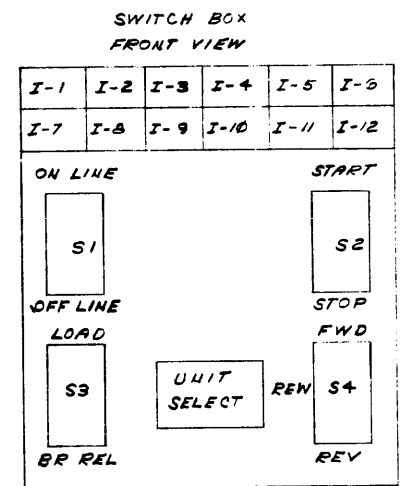
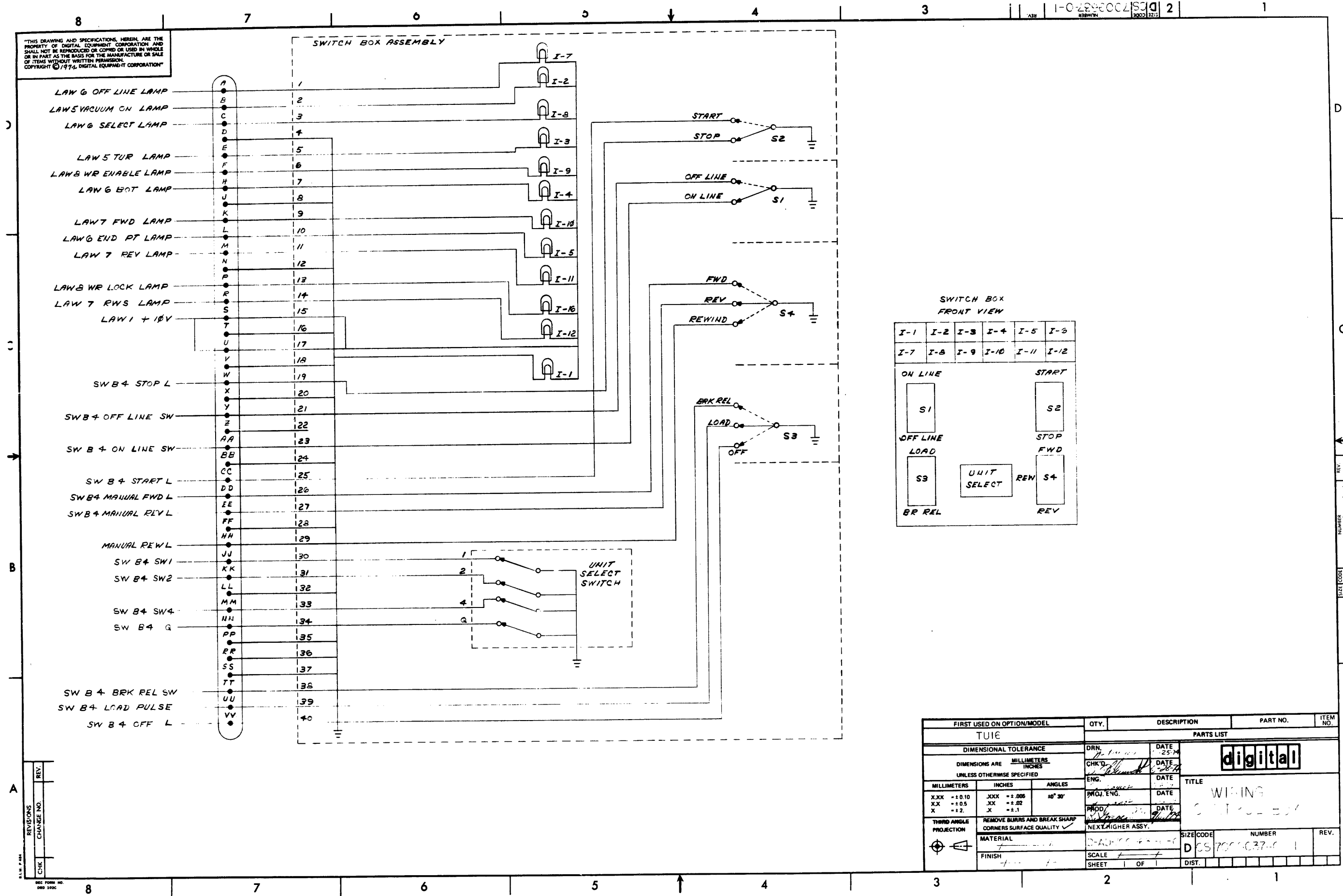

FIRST USED ON OPTION/MODEL	QTY.	DESCRIPTION	PART NO.	ITEM NO.
TU1E				
PARTS LIST				
DIMENSIONAL TOLERANCE		DRN.	DATE	
UNLESS OTHERWISE SPECIFIED		CHK'D.	DATE	
MILLIMETERS		ENG.	DATE	
INCHES		PROJ. ENG.	DATE	
ANGLES		PROD.	DATE	
X.XX ±0.10	JXX ±.005	TITLE		
XX ±0.5	JX ±.02	WIRING		
X ±2.	J ±.1	CONTROL BOX		
THIRD ANGLE PROJECTION	REMOVE BURRS AND BREAK SHARP CORNERS SURFACE QUALITY	NEXT HIGHER ASSY.		
MATERIAL	FINISH	SIZE CODE	NUMBER	REV.
		D	CS 7000-037-0	1
		SCALE		
		SHEET	OF	
		DIST.		

REVISIONS

REV.	CHANGE NO.
CHK	

DEC FORM NO. 080 1974

DO NOT SCALE DRAWING

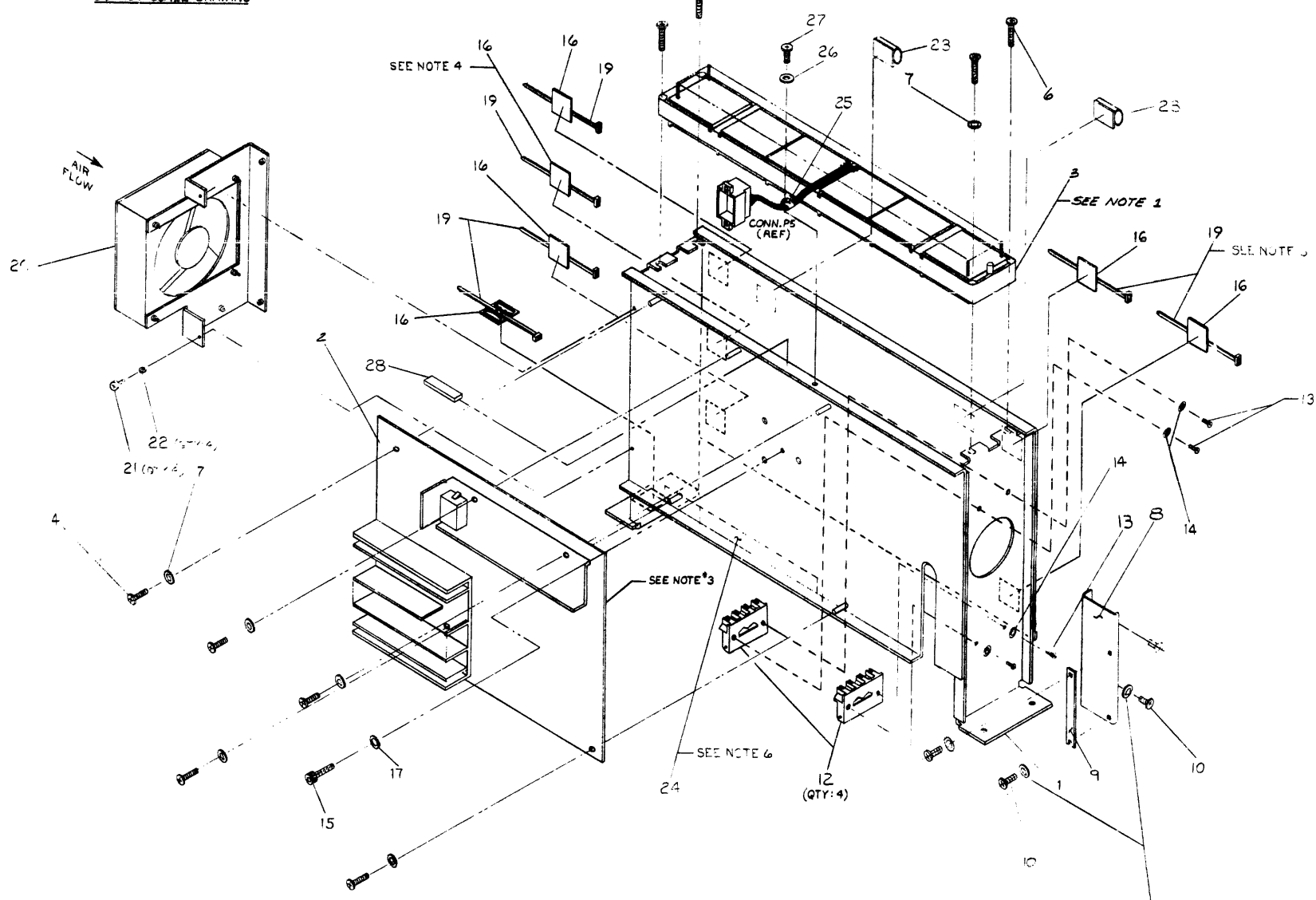

NOTES:

1. ITEM 3 TO BE MOUNTED UNDER FLANGES.
2. WHEN INSERTING MODULES INTO LOGIC ASSEMBLY CARD GUIDES (ITEM 12) WILL BE ADJUSTED BY SLIDING RIGHT OR LEFT SO AS TO PROPERLY ALIGN P.C. CARDS.
3. BEFORE ASSEMBLING ITEMS 1 AND 2, COAT MATING SURFACE OF DIODE HEAT SINK WITH THERMAL COMPOUND.
4. PLACE ADHESIVE BACK MOUNT DIRECTLY IN MIDDLE OF ENVELOPE, FLUSH WITH TOP RIDGE.
5. DELETE THE TWO MOUNTS OF THE DRIVES.
6. INSTALL ITEM 12 ACCORDING TO THE POSITION OF THE PARTS SURFACE LAYS IN FRONT PANEL.

QTY	DESCRIPTION	PARTS LIST	PART NO.	ITEM NO.
1	SCREW PAN HD 6-32 X 1/2 LG		9006021	10
1	WASHER, FLAT #4		9006052	26
1	CLAMP, CABLE 3/4 IN		9007013	25
1	WASHER, LOCK #4		9006086	13
1	SCREW PAN HD 4-40 X 3/4 LG		9006012	21
1	BRACKET, FAN ASSEMBLY		9006021	20
6	TIE WRAP		9007032	19
A/R	THERMAL COMPOUND		9008269	18
1	WASHER, SPLIT LOCK #8		9006090	17
6	MOUNT, ADHESIVE BACK		9008164	16
1	SCREW SOCKET HE 8-32 X 1/4		9009464	15
1	ELECTROSTATIC SHIELD		9006021	14
8	WASHER, INT TOOTH LOCK #4		9006032	14
6	SCREW PAN HD PH 2-18 X 3/16 LG		9006010	11
4	GUIDE, CABLE & EXTRA TIE		9006011	12
1	SCREW PAN HD PH 2-18 X 3/16 LG		9006021	10
1	PLATE, PRECISURE		9006011	11
1	BRACKET, CABLE CLAMP		9006011	11
13	WASHER #6 INT LOCK		9006033	7
4	SCREW PAN HD PH 2-18 X 3/16 LG		9006012	6
5	WASHER #6 INT LOCK		9006033	5
5	SCREW PAN HD PH 2-18 X 3/16 LG		9006021	4
1	LOGIC HARNESS ASSEMBLY (TU16)		9006011	3
1	P.C. BOARD ASSEMBLY (TU16)		9006011	3
1	LOGIC CHASSIS		9006011	1

REV	DATE	BY	CHKD	DESCRIPTION
1	10/15/64	W. SMITH	W. SMITH	INITIAL RELEASE
2	11/15/64	W. SMITH	W. SMITH	REVISION
3	12/15/64	W. SMITH	W. SMITH	REVISION
4	1/15/65	W. SMITH	W. SMITH	REVISION
5	2/15/65	W. SMITH	W. SMITH	REVISION
6	3/15/65	W. SMITH	W. SMITH	REVISION
7	4/15/65	W. SMITH	W. SMITH	REVISION
8	5/15/65	W. SMITH	W. SMITH	REVISION
9	6/15/65	W. SMITH	W. SMITH	REVISION
10	7/15/65	W. SMITH	W. SMITH	REVISION
11	8/15/65	W. SMITH	W. SMITH	REVISION
12	9/15/65	W. SMITH	W. SMITH	REVISION
13	10/15/65	W. SMITH	W. SMITH	REVISION
14	11/15/65	W. SMITH	W. SMITH	REVISION
15	12/15/65	W. SMITH	W. SMITH	REVISION

UNLESS OTHERWISE SPECIFIED, DIMENSIONS IN INCHES.

DATE: 10/15/64

BY: W. SMITH

CHKD: W. SMITH

SCALE: 1/8" = 1"

SHEET: 1 OF 1

SEE PARTS LIST

LOGIC ASSEMBLY (TU16)

E-AD-7009635-0-0

REVISIONS:

REV	DATE	DESCRIPTION
1	10/15/64	INITIAL RELEASE
2	11/15/64	REVISION
3	12/15/64	REVISION
4	1/15/65	REVISION
5	2/15/65	REVISION
6	3/15/65	REVISION
7	4/15/65	REVISION
8	5/15/65	REVISION
9	6/15/65	REVISION
10	7/15/65	REVISION
11	8/15/65	REVISION
12	9/15/65	REVISION
13	10/15/65	REVISION
14	11/15/65	REVISION
15	12/15/65	REVISION

This drawing and specifications, herein, are the property of Digital Equipment Corporation and shall not be reproduced or copied or used in whole or in part as the basis for the manufacture or sale of items without written permission.

**COPYRIGHT © 1974,
DIGITAL EQUIP. CORP.**

SIZE CODE NUMBER REV. 2
K WL TUI6-Ø-WL

B

B

↓

↑

A

A

REVISIONS		REV.
CHK	CHANGE NO.	
288	TUI6-00010	A
	<i>W. Dwyer 5-5-75</i>	
	J. HESS	
	<i>J. R. 9/25 5-7-75</i>	
288	TUI6-00013	B
	<i>W. Dwyer 7-25-75</i>	
	J. HESS	
	<i>John R. 9/25 7-10-75</i>	
288	TUI6-00021	C
	<i>P. Brown 25 JUNE 76</i>	
	H. DRAB	
	<i>Drab 6 Jul 76</i>	
288	TUI6-00022	D
	<i>Drab 2 Aug 76</i>	
	H. DRAB	
	<i>Drab 2 Aug 76</i>	
AK	TUI6-00027	E
K.T.	TUI6-00030	F
	<i>D. Chinnon 3 MAR. 77</i>	
	H. DRAB	
	<i>H. Drab 3-9-77</i>	

DEC FORM NO
DRB 109

FIRST USED ON OPTION MODEL	QTY.	DESCRIPTION	PART NO.	ITEM NO.
TUI6				
PARTS LIST				
DRN. <i>D. Drab</i>		DATE <i>2/20/76</i>	 digital EQUIPMENT CORPORATION <small>MAYNARD, MASSACHUSETTS</small>	
CHK'D. <i>D. Drab</i>		DATE <i>2/24/76</i>		
ENG. <i>J. R. Hess</i>		DATE <i>2-20-76</i>		
PROV. ENG. <i>J. R. Hess</i>		DATE <i>2-20-76</i>		
PROG. <i>D. Drab</i>		DATE <i>5-31-76</i>		
TITLE			<h1>WIRE LIST</h1> <h2>(TUI6)</h2>	
NEXT HIGHER ASSEMBLY				
D-AD-7009605-0-0				
SCALE <i>1/1</i>	SIZE CODE	NUMBER	REV.	
SHEET	K WL	TUI6-Ø-WL	F	
	DIST.			

4

3

↑

2

1

U16.E UN NAME	*RF280.V34(63)-1 A/P PIN NAME	23-AUG-76 ORDER PIN	BAY - ORDER	Q	DRAW	RV PG Y	X Z	REMARKS	28-Oct-76	8135 NC LENGTH FLAG	PAGE 4 EXCEPTIONS	RUN NUMBER
YESB (SB) L	C03K1		1-01 *				1			3-6/8		42
YESB (SB) L	D03V1		1-02 *				2			1-6/8		42
YESB (SB) L	F01D1		1-03 *									42
YESB (SB) L			1							5-4/8	1400000000	42
ID (SB) 00 L	D01V2		1-01 *				1			1-4/8		43
ID (SB) 00 L	D03V2		1-02 *									43
ID (SB) 00 L			1							1-4/8	1400000000	43
ID (SB) 01 L	D01U2		1-01 *				1			1-4/8		44
ID (SB) 01 L	D03U2		1-02 *									44
ID (SB) 01 L			1							1-4/8	1400000000	44
ID (SB) 02 L	D01S2		1-01 *				1			1-4/8		45
ID (SB) 02 L	D03S2		1-02 *									45
ID (SB) 02 L			1							1-4/8	1400000000	45
ID (SB) 03 L	D01R2		1-01 *				1			1-4/8		46
ID (SB) 03 L	D03R2		1-02 *									46
ID (SB) 03 L			1							1-4/8	1400000000	46
ID (SB) 04 L	D01P2		1-01 *				1			1-4/8		47
ID (SB) 04 L	D03P2		1-02 *									47
ID (SB) 04 L			1							1-4/8	1400000000	47
ID (SB) 05 L	C01H2		1-01 *				1			1-4/8		48
ID (SB) 05 L	C03H2		1-02 *									48
ID (SB) 05 L			1							1-4/8	1400000000	48
ID (SB) 06 L	C01F2		1-01 *				1			1-4/8		49
ID (SB) 06 L	C03F2		1-02 *									49
ID (SB) 06 L			1							1-4/8	1400000000	49
ID (SB) 07 L	C01E2		1-01 *				1			1-4/8		50
ID (SB) 07 L	C03E2		1-02 *									50
ID (SB) 07 L			1							1-4/8	1400000000	50
ID (SB) P L	C01D2		1-01 *				1			1-2/8		51
ID (SB) P L	C03A1		1-02 *									51
ID (SB) P L			1							1-2/8	1400000000	51
D 00 L	A04F1		1-01 *				1			5-7/8		52
D 00 L	C03D1		1-02 *									52
D 00 L			1							5-7/8	1400000000	52
D 01 L	D03U1		1-01 *				1			1-7/8		53
D 01 L	F04E1		1-02 *									53
D 01 L			1							1-7/8	1400000000	53
D 02 L	A04B1		1-01 *				1			6-5/8		54
D 02 L	C03E1		1-02 *									54
D 02 L			1							6-5/8	1400000000	54

U16.E UN NAME	*RF280.V34(63)-1 A/P PIN NAME	23-AUG-76 ORDER PIN	BAY - ORDER	Q	DRAW	RV PG Y	X Z	REMARKS	28-Oct-76	8135 NC LENGTH FLAG	PAGE 5 EXCEPTIONS	RUN NUMBER
D 03 L	D03M1		1-01 *				1			6-7/8		55
D 03 L	F04K1		1-02 *									55
D 03 L			1							6-7/8	1400000000	55
D 04 L	A04F1		1-01 *				1			3-3/8		56
D 04 L	C03H1		1-02 *									56
D 04 L			1							3-3/8	1400000000	56
D 05 L	C03M1		1-01 *				1			1		57
D 05 L	C04P1		1-02 *									57
D 05 L			1							1-0/8	1400000000	57
D 06 L	C03M1		1-01 *				1			1		58
D 06 L	C04R1		1-02 *									58
D 06 L			1							1-0/8	1400000000	58
D 07 H	C03S1		1-01 *				1			4-1/8		59
D 07 H	L04V1		1-02 *									59
D 07 H			1							4-1/8	1400000000	59
D P L	F04K1		1-01 *				1			3-3/8		60
D P L	C03K1		1-02 *									60
D P L			1							3-3/8	1400000000	60
EC (SB) L	C01H2		1-01 *				1			5-7/8		61
EC (SB) L	D03K2		1-02 *									61
EC (SB) L			1							5-7/8	1400000000	61
ECORD PULSE L	F03D1		1-01 *				1			0-5/8		62
ECORD PULSE L	D03L2		1-02 *				2			1		62
ECORD PULSE L	D02L2		1-03 *									62
ECORD PULSE L			1							7-5/8	1400000000	62
EV (SB) L	A02E1		1-01 *				1			4-5/8		63
EV (SB) L	C01V2		1-02 *									63
EV (SB) L			1							4-5/8	1400000000	63
SDO (SB) I	C01K2		1-01 *				1			1-4/8		64
SDO (SB) I	C03K2		1-02 *									64
SDO (SB) I			1							1-4/8	1400000000	64
UNNING H	D02R2										1-PIN MOD	65
WVD (SB) I	A02D2		1-01 *				1			4-5/8		66
WVD (SB) I	C01P2		1-02 *									66
WVD (SB) I			1							4-5/8	1400000000	66
WS (SB) I	A02M1		1-01 *				1			11-1/8		67
WS (SB) I	F01M2		1-02 *									67
WS (SB) I			1							11-1/8	1400000000	67
DWN (SB) I	A02M2		1-01 *				1			11-7/8		68
DWN (SB) I	F01S2		1-02 *									68
DWN (SB) I			1							11-7/8	1400000000	68

THIS DRAWING AND SPECIFICATIONS HEREIN ARE THE PROPERTY OF DIGITAL EQUIPMENT CORPORATION AND SHALL NOT BE REPRODUCED OR COPIED OR USED IN WHOLE OR IN PART AS THE BASIS FOR THE MANUFACTURE OR SALE OF ITEMS WITHOUT WRITTEN PERMISSION. COPYRIGHT © 1974, DIGITAL EQUIPMENT CORPORATION

NOTES:

- USE CABLE SLOTS AS FOLLOWS

	END-OF-BUS	MIDDLE-OF-BUS
A,B	M9001YB	M9001
C,D	M8913YA	M8913
E,F	M9001YC	M9001-YA
- M8912 CAN BE USED AS A TEST FUNCTION GENERATOR IN SLOT 3 A/B. IT DRIVES SERIAL NO AND DRIVE TYPE LINES IN SLOT 3 E/F. THE TU16 CAN NOT OPERATE ON-LINE WITH M8912 IN SLOT 3 A/B.
- ELECTROSTATIC SHIELD IS POSITIONED BETWEEN THE G056 MODULE AND THE M8911/M8912 MODULES.
- G066 REPLACES G056. G066 BOARD AND G066 READ CABLE MUST BE ORDERED TOGETHER. CABLE ISN'T ATTACHED TO BOARD.

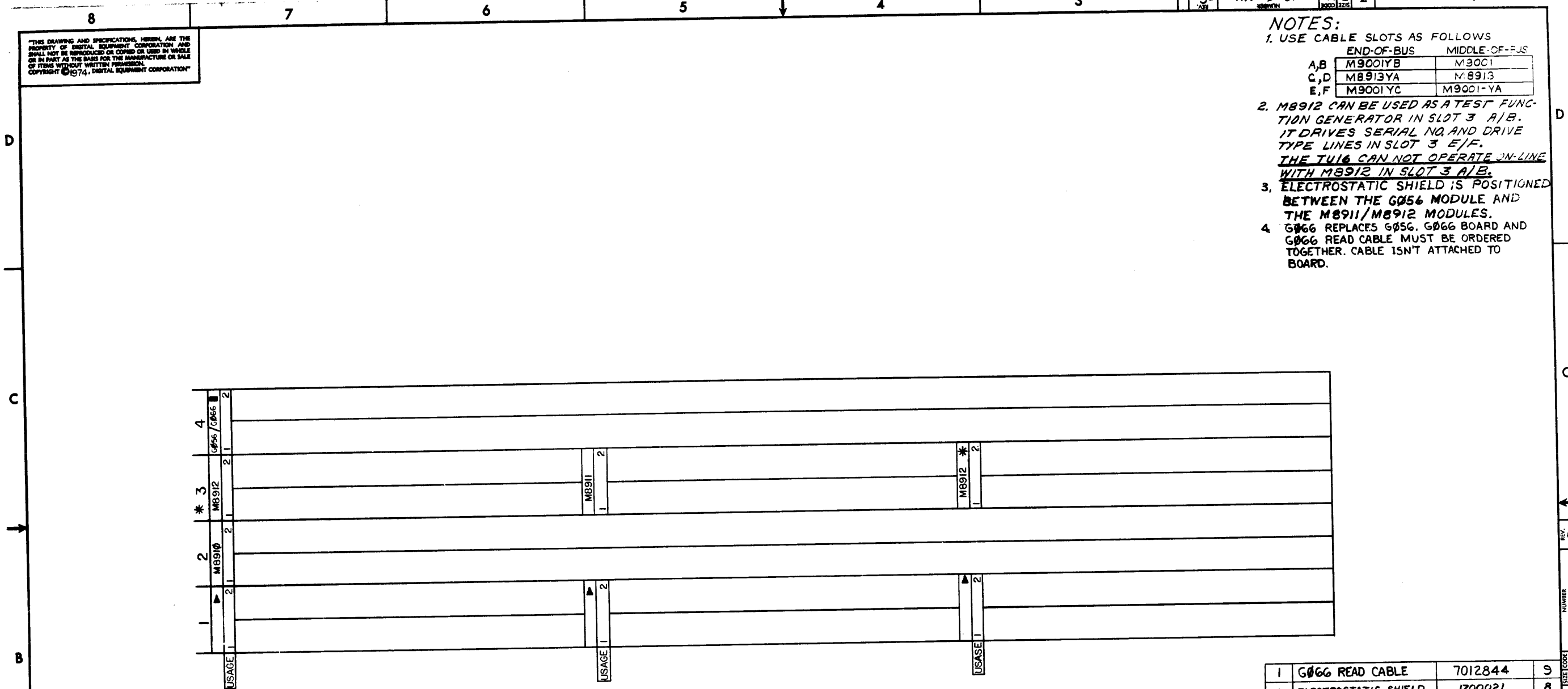

QTY.	DESCRIPTION	PART NO.	ITEM NO.
1	G066 READ CABLE	7012844	9
1	ELECTROSTATIC SHIELD	1700021	8
A/R	GEN PURPOSE CARD (ESP)	M9001-YA	7
1	CLK & TEST LOGIC	M8911	6
A/R	DATA DRIVER	M8913	5
1	READ AMP (RAI)	G056/G066	4
2	SLAVE TEST FUNCT GEN	M8912	3
1	LOGIC & WRITE BOARD	M8910	2
A/R	GEN PURPOSE CARD (A/B)	M9001	1

REV.	CHG	NO.	REV.
A	0000	0000	0000
B	0007	0007	0007
C	0003	0003	0003
D	0007	0007	0007
E	0007	0007	0007

REVISIONS:
 J. HESS
 J. HESS
 J. HESS
 J. HESS
 H. DRAB
 29 APR 77

FIRST USED ON OPTION/MODEL		TU16										
DIMENSIONAL TOLERANCE		PARTS LIST										
DIMENSIONS ARE MILLIMETERS UNLESS OTHERWISE SPECIFIED		<table border="1"> <tr> <td>DRN</td> <td>DATE</td> <td rowspan="4"> </td> </tr> <tr> <td>CHKD</td> <td>DATE</td> </tr> <tr> <td>ENG</td> <td>DATE</td> </tr> <tr> <td>PRD</td> <td>DATE</td> </tr> </table>		DRN	DATE		CHKD	DATE	ENG	DATE	PRD	DATE
DRN	DATE											
CHKD	DATE											
ENG	DATE											
PRD	DATE											
MILLIMETERS	INCHES	ANGLES	TITLE									
±0.10	±0.006	±0°30'	MODULE UTILIZATION									
±0.08	±0.002											
±0.2	±0.1											
THIRD ANGLE PROJECTION	REMOVE BURRS AND BREAK EDGES	CORNER SURFACE QUALITY	SIZE CODE									
			DUA-TU16-0-0									
MATERIAL			NUMBER									
			D MU TU16-0-MU									
FINISH			REV.									
			C									
SHEET	OF	DIST.										

"THE DRAWING AND SPECIFICATIONS HEREIN ARE THE PROPERTY OF DIGITAL EQUIPMENT CORPORATION AND SHALL NOT BE REPRODUCED OR COPIED OR USED IN WHOLE OR IN PART AS THE BASIS FOR THE MANUFACTURE OR SALE OF ITEMS WITHOUT WRITTEN PERMISSION. COPYRIGHT © 1974, DIGITAL EQUIPMENT CORPORATION"

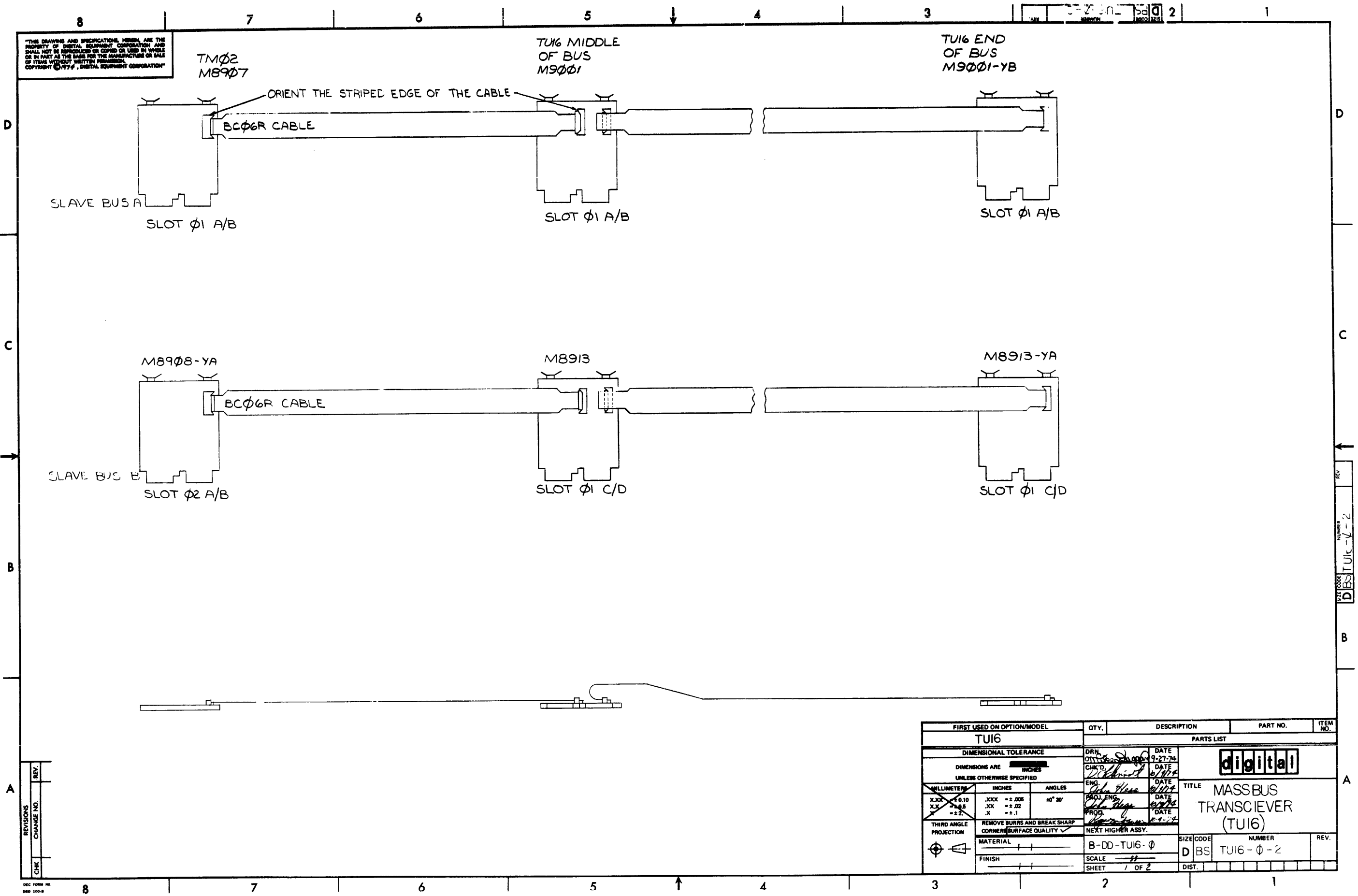

REV.	
CHANGE NO.	
CHK	

FIRST USED ON OPTION/MODEL TUI6	QTY.	DESCRIPTION	PART NO.	ITEM NO.
PARTS LIST				
DIMENSIONAL TOLERANCE		DRN. DATE	9-27-74	
DIMENSIONS ARE INCHES		CHK'D. DATE	10/1/74	
UNLESS OTHERWISE SPECIFIED		ENG. DATE	10/1/74	
MILLIMETERS	INCHES	ANGLES	TITLE	
X.XX ± 0.10	.XX ± .005	10° 30'	digital	
X.X ± 0.5	.XX ± .02		TITLE MASSBUS	
X ± .2	.X ± .1		TRANSCIEVER	
			(TUI6)	
THIRD ANGLE PROJECTION	REMOVE BURRS AND BREAK SHARP CORNERS SURFACE QUALITY	NEXT HIGHER ASSY.	SIZE CODE	NUMBER
			D BS	TUI6-φ-2
MATERIAL	FINISH	SCALE	DIST.	REV.
		SCALE 1/2		
		SHEET 1 OF 2		

REV. NUMBER
D BS TUI6-φ-2

"THIS DRAWING AND SPECIFICATIONS, HEREIN, ARE THE PROPERTY OF DIGITAL EQUIPMENT CORPORATION AND SHALL NOT BE REPRODUCED OR COPIED OR USED IN WHOLE OR IN PART AS THE BASIS FOR THE MANUFACTURE OR SALE OF ITEMS WITHOUT WRITTEN PERMISSION. COPYRIGHT © 1974, DIGITAL EQUIPMENT CORPORATION"

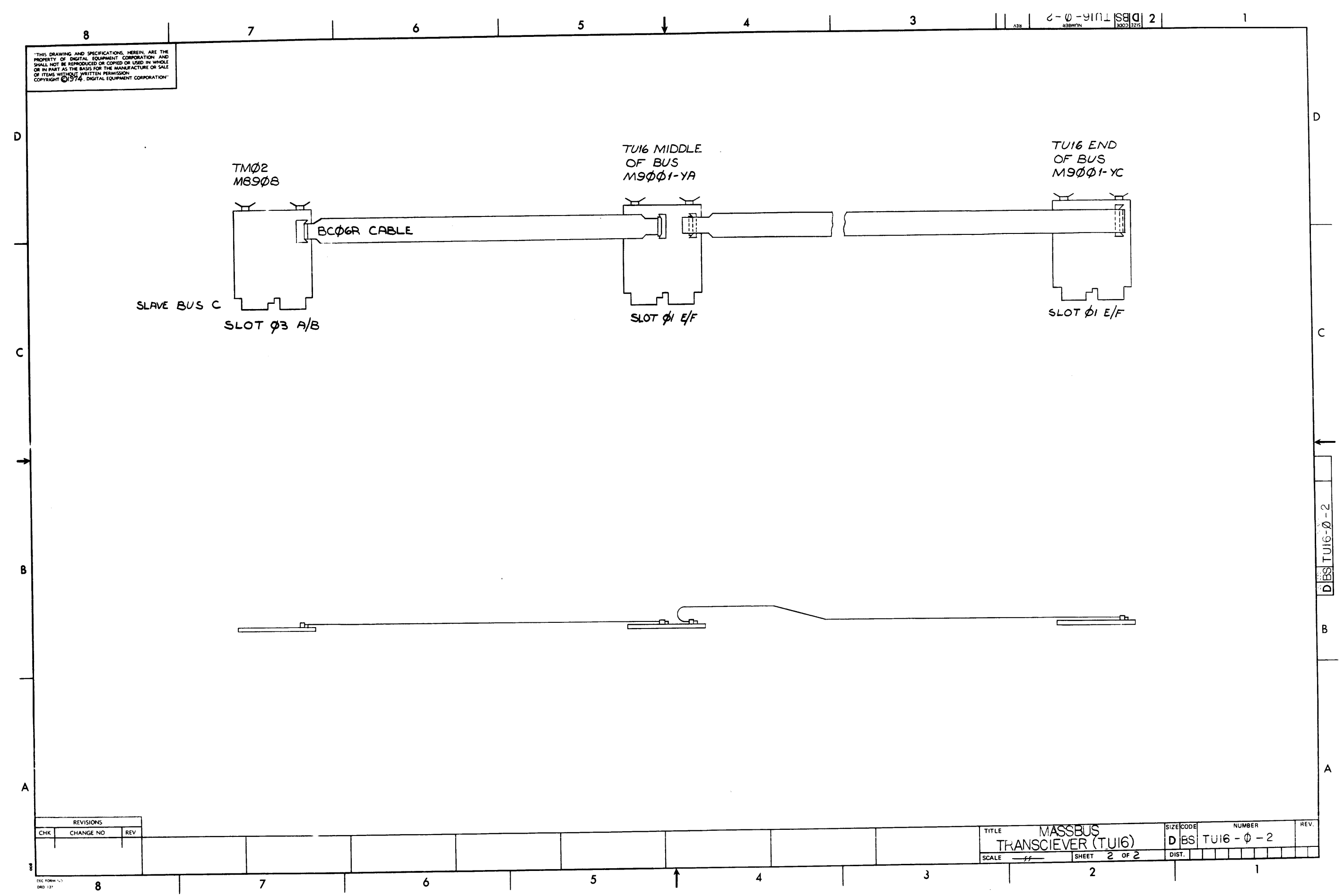

REVISIONS		
CHK	CHANGE NO	REV

TITLE	MASSBUS TRANSCIEVER (TUI6)	SIZE CODE	D BS	NUMBER	TUI6 - Ø - 2	REV.	
SCALE	ff	SHEET	2 OF 2	DIST.			

THIS DRAWING AND SPECIFICATIONS SHALL BE THE PROPERTY OF THE UNITED STATES GOVERNMENT. IT IS TO BE REPRODUCED AND TRANSMITTED IN ANY FORM AND BY ANY MEANS, ELECTRONIC OR MECHANICAL, INCLUDING PHOTOCOPYING, RECORDING, OR BY ANY INFORMATION STORAGE AND RETRIEVAL SYSTEM, WITHOUT PERMISSION IN WRITING FROM THE ASSISTANT SECRETARY OF DEFENSE (ASST. SEC. DEF.), MILITARY PERSONNEL OPERATIONS.

LEGEND	
NUMBER	VARIATION
7009634-1	9 TRACK 60~
7009634-2	9 TRACK 30~

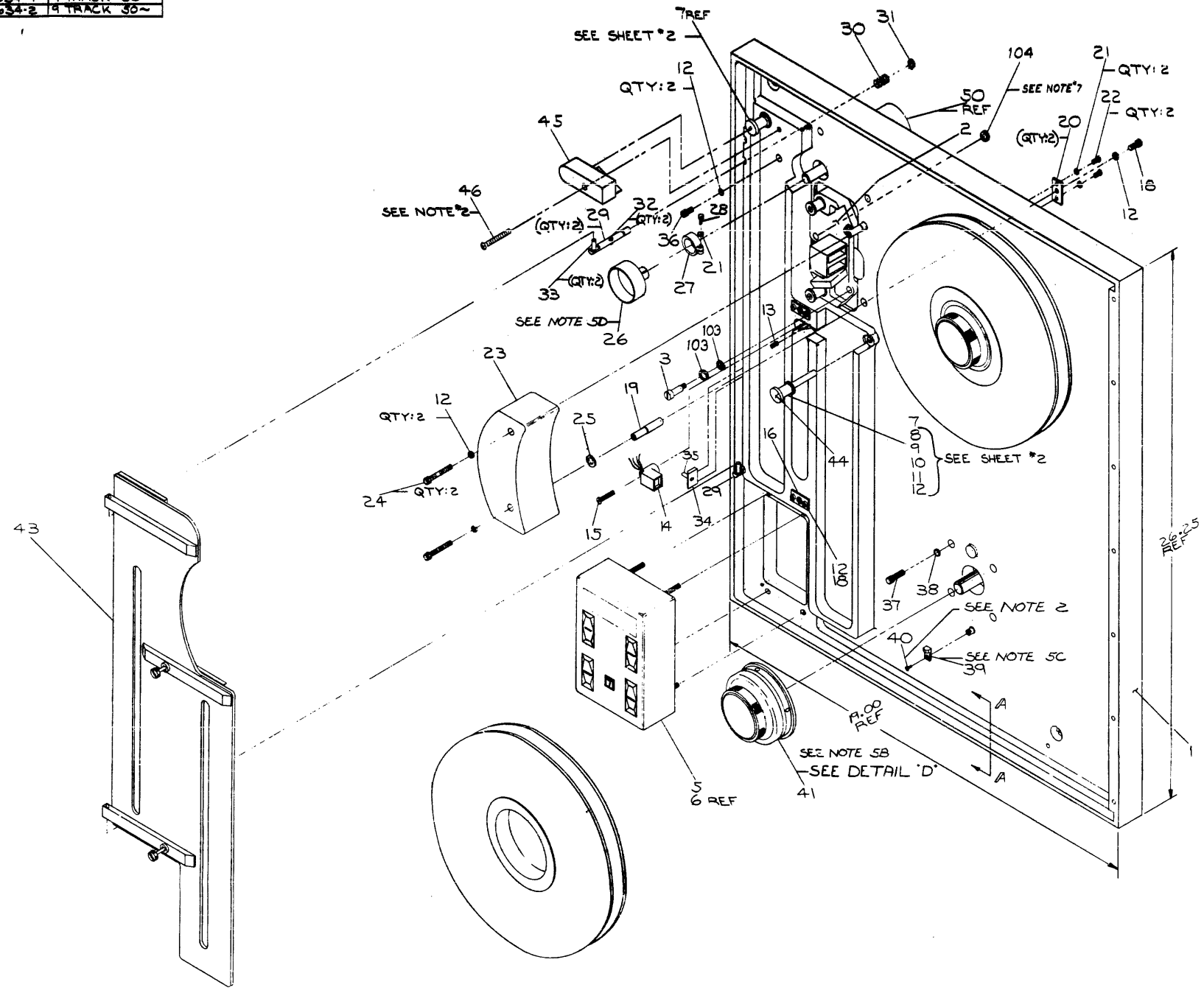

- NOTES:**
- FOR HARNESS CONNECTIONS, WIRING REFER TO SHEET #5.
 - THESE ITEMS TO BE COATLINED AND LOCKTITE AT ASSY.
 - THESE ITEMS TO HAVE THREAD COATED WITH TEFLON PLUMBERS TAPE.
 - THESE ITEMS TO BE CEMENTED IN PLACE AT ASSY USING HYBOND ADHESIVE.
 - GAGES REQUIRED:
 - A. ROLLER GUIDE GAGE #905463
 - B. HUB GAGE #905461
 - C. READ WRITE REL. GAGE #905499
 - D. CAPSTAN GAGE #905676
 - REELS (ITEMS 1 & 2) ARE SUPPLIED AT UNIT ASSY.
 - PRECISION SPACERS (3 REQ) THICKNESS PER SPEC. A-SP-TU16-0-4
 - INSTALL FOAM FILTER, MEDIUM.
 - INSTALL PLUG FILTER.
 - INSTALL FOAM FILTER, SMALL.
 - INSTALL FOAM FILTER, LARGE.
 - USE UNTAPPED HOLE APPROXIMATELY 3-1/4 IN. FROM SURFACE MARKED Z.
 - INSTALL HEAD PLUG FILTER.
 - PUT EXT. STAR WASHER ON BOTH SIDES OF GROUND STRAP.

1	2	3	4	5	6	7	8	9	10	11	12	13	14	15	16	17	18	19	20	21	22	23	24	25	26	27	28	29	30	31	32	33	34	35	36	37	38	39	40	41	42	43	44	45	46	47	48	49	50	51	52	53	54	55	56	57	58	59	60	61	62	63	64	65	66	67	68	69	70	71	72	73	74	75	76	77	78	79	80	81	82	83	84	85	86	87	88	89	90	91	92	93	94	95	96	97	98	99	100
---	---	---	---	---	---	---	---	---	----	----	----	----	----	----	----	----	----	----	----	----	----	----	----	----	----	----	----	----	----	----	----	----	----	----	----	----	----	----	----	----	----	----	----	----	----	----	----	----	----	----	----	----	----	----	----	----	----	----	----	----	----	----	----	----	----	----	----	----	----	----	----	----	----	----	----	----	----	----	----	----	----	----	----	----	----	----	----	----	----	----	----	----	----	----	----	----	----	----	-----

FIRST USED ON OPTION MODEL		QTY.	DESCRIPTION	PART NO.	ITEM NO.
TU16					
DIMENSIONAL TOLERANCE		PARTS LIST			
DIMENSIONS ARE IN INCHES UNLESS OTHERWISE SPECIFIED		digital			
MILLIMETER		TITLE			
X.XX ± .005		TAPE TRANSPORT ASSY			
X.X ± .002		SIZE CODE			
X ± .001		NUMBER			
FINISH		SCALE			
PRODUCTION		SHEET			
MATERIAL		D: UA-TU6-0-0			
SEE PARTS LIST		E AD 7009634-0-C			
FINISH		SCALE			
PRODUCTION		SHEET			

7009634-0-C

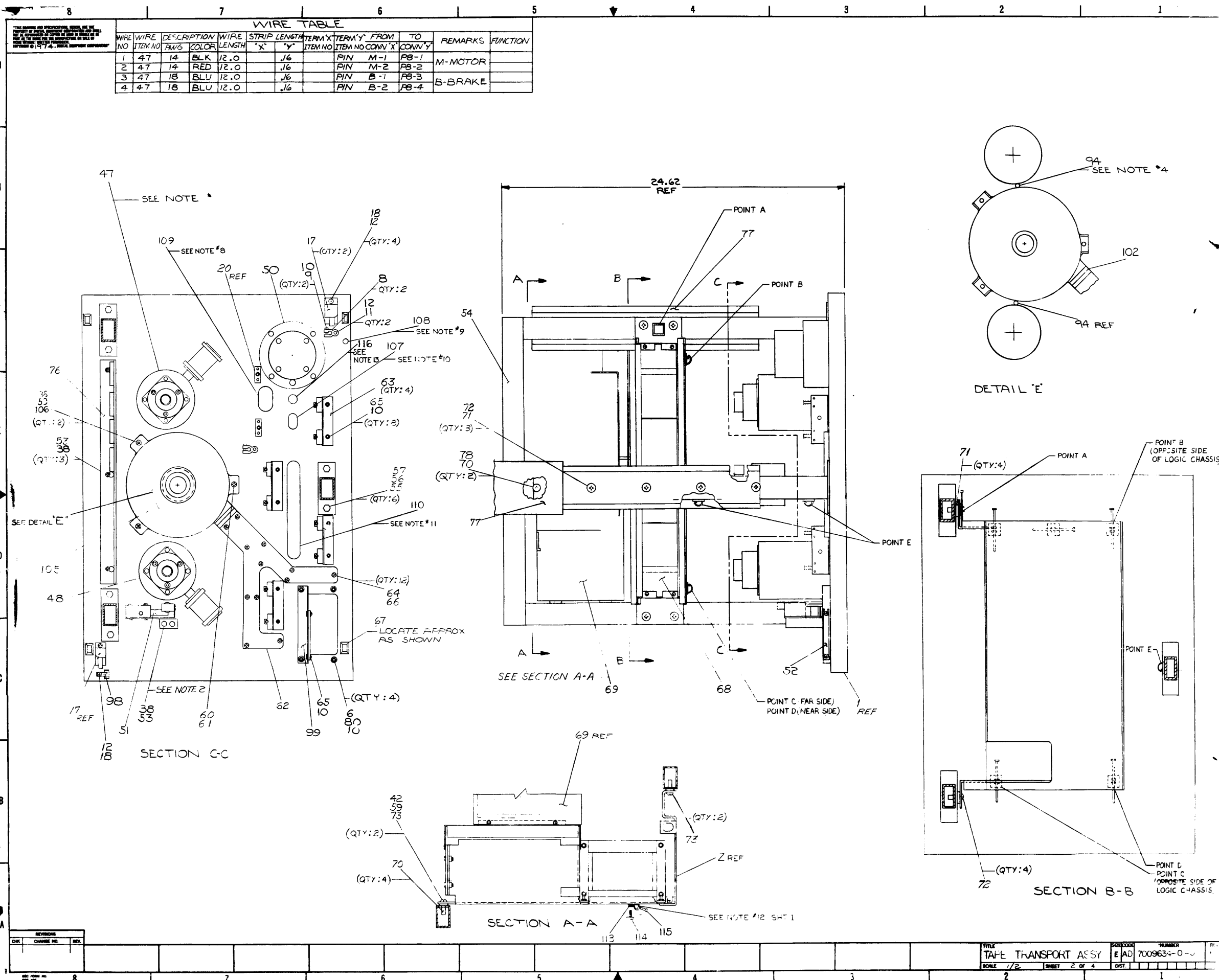

WIRE TABLE

WIRE NO	ITEM NO	DESCRIPTION	WIRE COLOR	WIRE LENGTH	STRIP LENGTH	TERMINAL 'X'	TERMINAL 'Y'	FROM	TO	REMARKS	FUNCTION
1	47	14	BLK	12.0	.16	PIN	M-1	P8-1	M-MOTOR		
2	47	14	RED	12.0	.16	PIN	M-2	P8-2	M-MOTOR		
3	47	18	BLU	12.0	.16	PIN	B-1	P8-3	B-BRAKE		
4	47	18	BLU	12.0	.16	PIN	B-2	P8-4	B-BRAKE		

REV	DESCRIPTION

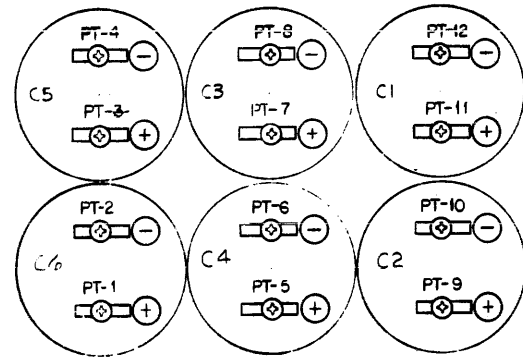

TOP VIEW F-F
SHOWN WITH CAPACITOR
GUARD REMOVED

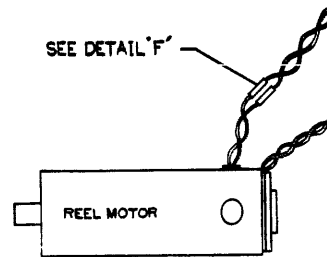

DETAIL 'F'
COVER WITH SHRINK TUBING
2-1/4 IN. LG. + SHRINK OVER
TUBE.

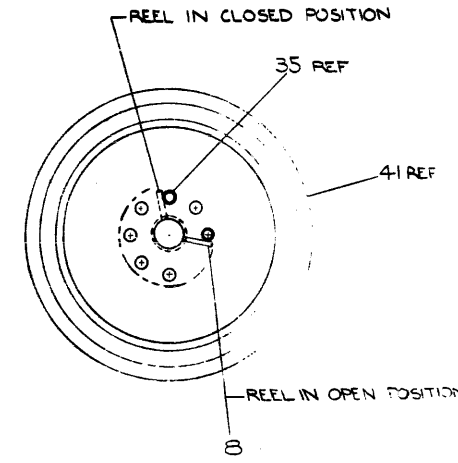

DETAIL 'D'

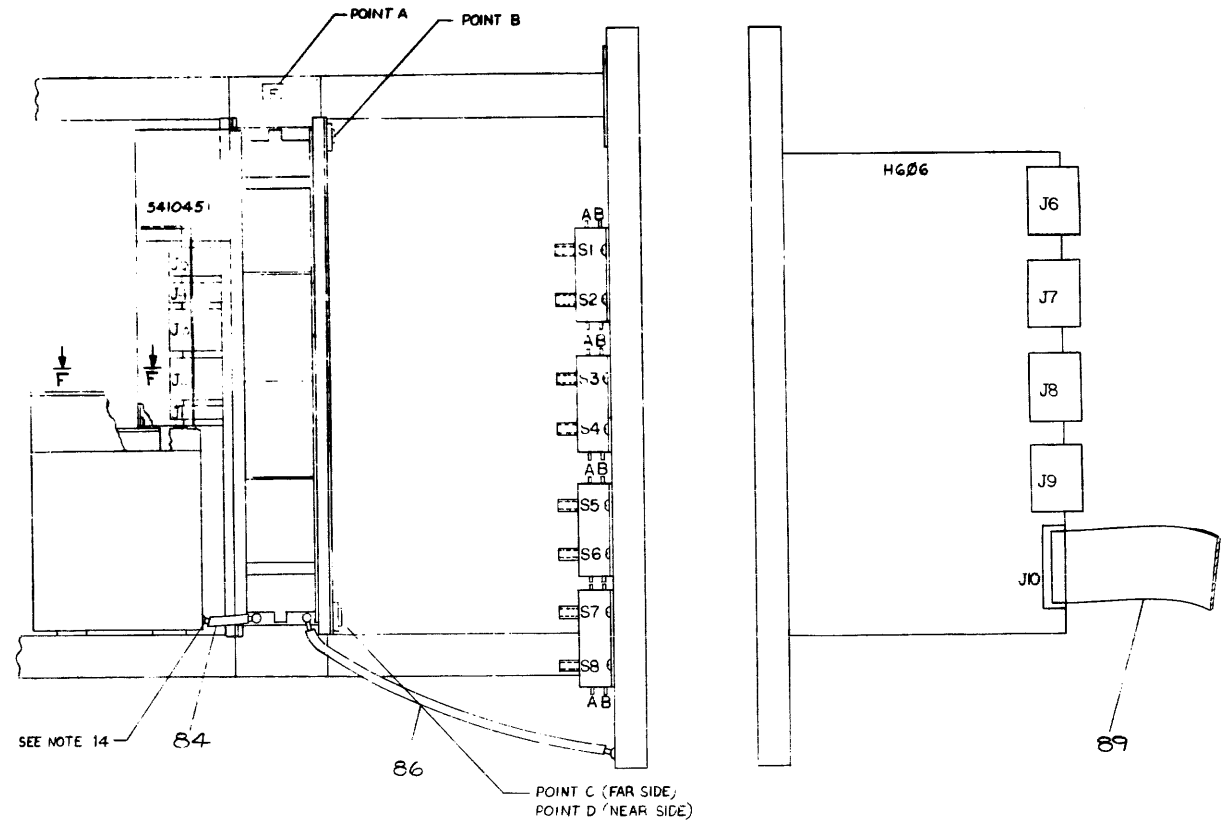
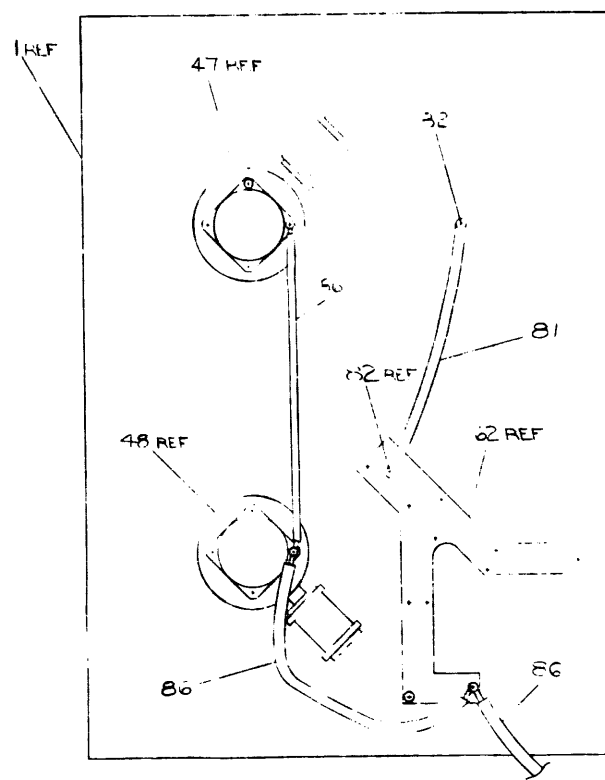

SEE NOTE 14

POINT C (FAR SIDE)
POINT D (NEAR SIDE)

REV	REVISIONS

TITLE	NUMBER	REV
TAPE TRANSPORT ASSY	7009634-0-C	1

147 7009634-0-0

THIS DRAWING AND SPECIFICATIONS HEREON ARE THE PROPERTY OF DIGITAL EQUIPMENT CORPORATION AND SHALL NOT BE REPRODUCED OR COPIED IN WHOLE OR IN PART AS THE BASIS FOR THE MANUFACTURE OR SALE OF ITEMS WITHOUT WRITTEN PERMISSION. COPYRIGHT © 1975, DIGITAL EQUIPMENT CORPORATION

ITEM NO	DESCRIPTION	FROM		TO		TIE DOWN POINT (SEE NOTE B)	REMARKS
		AWG	COLOR	CONNECTION	WITH		
22	WHT/YEL			VAC SW HARN - TB-1		VAC SW S1-A	B
18	BLK			- TB-2		S1-B	
22	WHT/GRY			- TB-3		S2-A	D
18	BLK			- TB-4		S2-B	
22	WHT/YEL			- PT-18		LOGIC C02U1	B
22	GRN			- PT-19		LOGIC C02U2	B
22	WHT/YEL			- TB-5		VAC SW S3-A	B
18	BLK			- TB-6		S3-B	
22	WHT/BLU			- TB-7		S4-A	D
18	BLK			- TB-8		S4-B	
22	WHT/BRN			- TB-9		S5-A	D
18	BLK			- TB-10		S5-B	
22	GRN			- TB-11		S6-A	
22	GRN			- TB-12		S6-B	
22	WHT/ORN			- TB-13		S7-A	D
18	BLK			- TB-14		S7-B	
22	GRN			- TB-15		S8-A	
18	BLK			- TB-16		S8-B	
16	BLK			- E-17		ITEM 62 DEC PLATE - GND	10S
				- P13		R/W INTERLOCK - J13	C
				VAC SW HARN - P4		HG06 J9	C
14	BLU			CAP. HARN - TB-1		CAPACITOR BANK PT-11	
	BLK			TB-2		PT-12	
	WHT			TB-3		PT-8	
	BLK			TB-4		PT-7	
	BLK			TB-5		PT-4	
	BRN			TB-6		PT-3	
	BLK			TB-7		PT-2	
	RED			TB-8		PT-1	
	BLK			TB-9		PT-6	
	VIO			TB-10		PT-5	
	BLK			TB-11		PT-10	
14	YEL			TB-12		PT-9	
				CAP. HARN - P3		54-12242 J3	
5				CONT. BOX CABLE		M8910 J1	
68				LOGIC ASSY - P5		54-12240 J5	
69				TRANSFORMER - P2		54-12240 J2	
89				BC05 L		HG06 J10	
				BC05 L		M8910 J2	
92				SERVO BD HARN - P4		54-12242 J4	
				SERVO BD HARN - P7		HG06 J7	
	RED			EOT/BOT ASSEMBLY		LOGIC	E
	ORN			EOT/BOT ASSEMBLY		LOGIC	E
	YEL			EOT/BOT ASSEMBLY		LOGIC	E
	BRN			EOT/BOT ASSEMBLY		LOGIC	E
				G056 CABLE - G056		R/W HEAD ASSEMBLY	A,B
				WRITE CABLE		M8910 J3	A
				WRITE CABLE		R/W HEAD ASSEMBLY	B

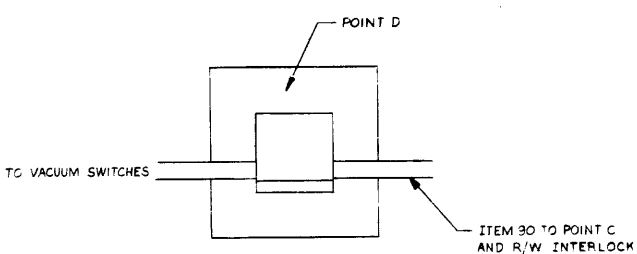
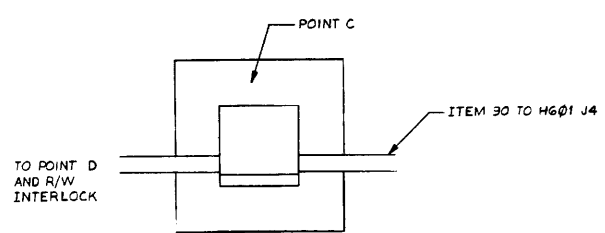
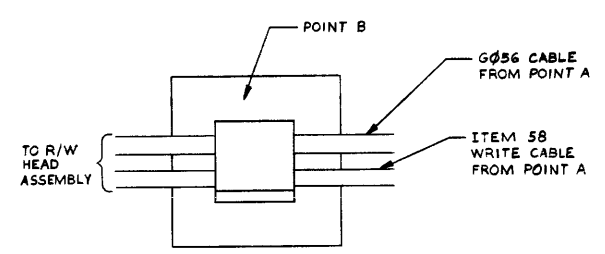
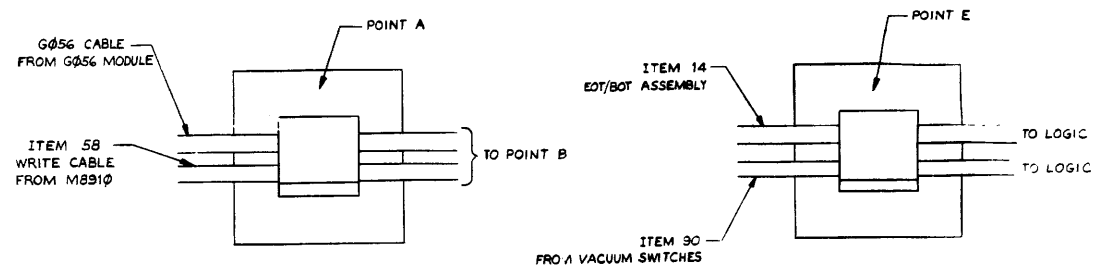

REVISIONS		
CHK	CHANGE NO.	REV.

"THIS DRAWING AND SPECIFICATIONS HEREIN ARE THE PROPERTY OF DIGITAL EQUIPMENT CORPORATION AND SHALL NOT BE REPRODUCED OR COPIED OR USED IN WHOLE OR IN PART AS THE BASIS FOR THE MANUFACTURE OR SALE OF ITEMS WITHOUT WRITTEN PERMISSION. COPYRIGHT © 1976, DIGITAL EQUIPMENT CORPORATION"

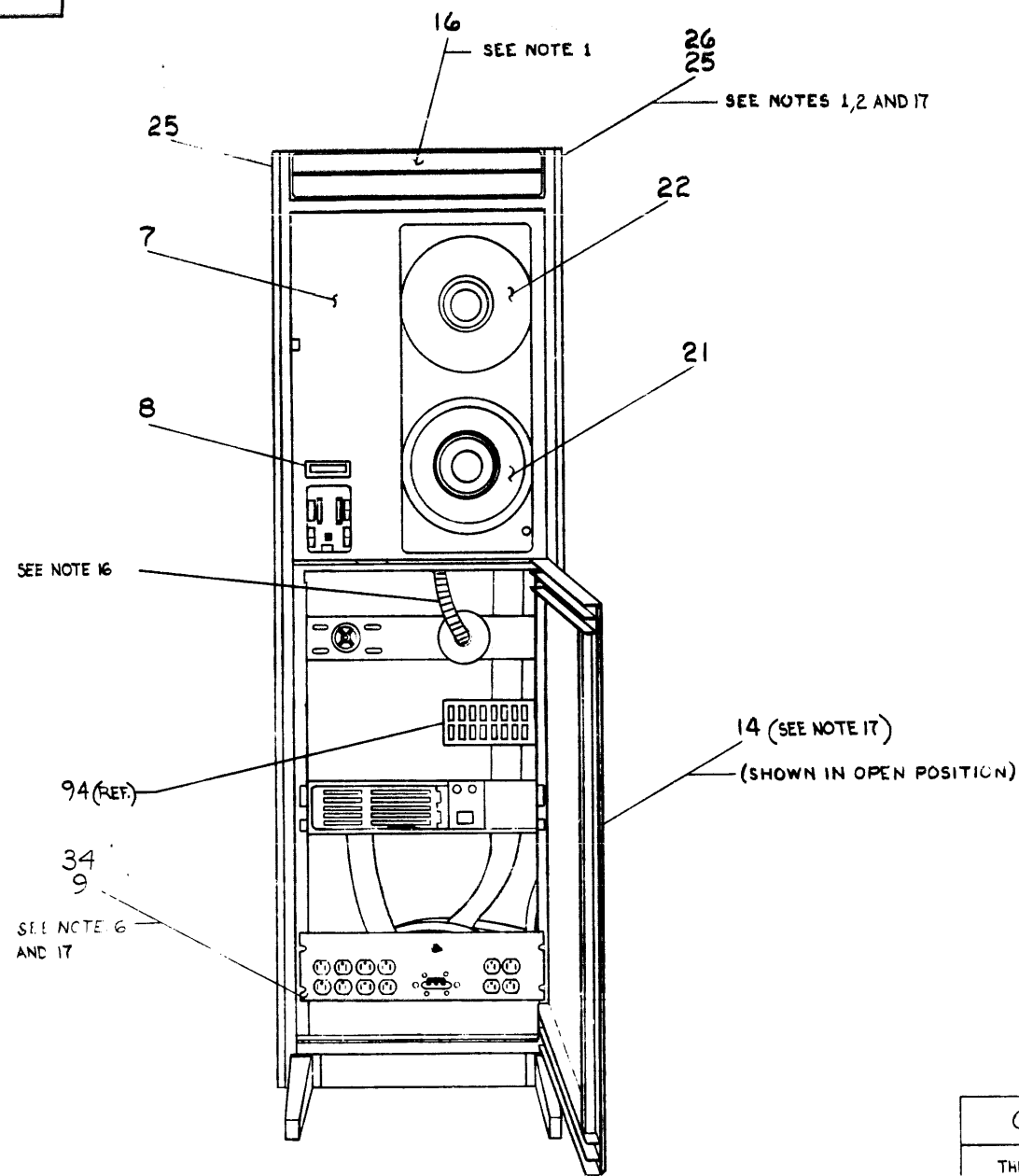

FRONT VIEW

CAUTION
THIS SHEET IS FOR THE TU16 IN THE H950 SERIES CAB

NUMBER	VARIATION	
	DESCRIPTION	VOLTAGE
TU16-EE	MAG TAPE SLAVE UNIT 45 IPS 9 TRACK PE/NRZI	115V, 60HZ
TU16-EF	MAG TAPE SLAVE UNIT 45 IPS 9 TRACK PE/NRZI	230V, 60HZ
TU16-EH	MAG TAPE SLAVE UNIT 45 IPS 9 TRACK PE/NRZI	115V, 60HZ
TU16-EJ	MAG TAPE SLAVE UNIT 45 IPS 9 TRACK PE/NRZI	230V, 50HZ
TU16-EA	TU16-EE & TM02-FA	115V, 60HZ
TU16-EB	TU16-EF & TM02-FB	230V, 60HZ
TU16-EC	TU16-EH & TM02-FA	115V, 50HZ
TU16-ED	TU16-EJ & TM02-FB	230V, 60HZ
TU16-EK	TU16-EE & TM02-FC	115V, 60HZ
TU16-EL	TU16-EF & TM02-FD	230V, 60HZ
TU16-EM	TU16-EH & TM02-FC	115V, 50HZ
TU16-EN	TU16-EJ & TM02-FD	230V, 50HZ
TU16-AA THROUGH-AJ	TU16 IN H9500 SERIES CAB (CORP. CAB)	SEE SHEETS 5, 3, 6

NOTES:

- THE CORRECT DEC PART NUMBER VARIATION FOR ITEMS *16 & 25 SHOULD BE DETERMINED BY THE SYSTEM THAT THE TU16 IS TO BE INCLUDED WITH.
- THE QUANTITY REQUIRED FOR THE H952-A END PANEL ASSY (ITEM *25) AND THE H952-GA FILLER STRIP ASSY (ITEM *26-NOT SHOWN) IS DETERMINED BY WHETHER THE TU16 IS INCLUDED IN A SYSTEM OR WHETHER IT STANDS ALONE.
- INFORMATION FOR CONNECTING THE CABLES (ITEM *17) TO TAPE TRANSPORT (ITEM *6, *35) REFER TO DNG NO. D-MU-TU16-0-MU.
- PHANTOM LINES REPRESENT TRANSPORT ASSY IN CLOSED POSITION TO SHOW LOCATION OF SHIPPING BRACKETS (ITEM *38).
- TO CONVERT FROM 120 TO 240-VAC OPERATION, CUT MALE END FROM TU16'S POWER CORD, AND CONNECT END OF CORD TO 240 VAC MALE CONNECTOR, ITEM *43 (NOT SHOWN).
- POWER CORD ROUTING: 861-CABLE CLAMP (ITEM *42-NOT SHOWN) THROUGH MAN NUT, SCREW, AND WASHER MOUNT ON RIGHT SIDE REAR HOLE *10 ROUTE CORD THROUGH CLAMP AND OUT BOTTOM OF CABINET. TU16-ROUTE CORD THRU CABLE CLAMP (ITEM 54 NOT SHOWN) LOCATED IN HOLE *67 ON LEFT FRONT SIDE OF CABINET OUTSIDE OF CHASSIS SLIDE AND INTO PLUG ON 861. USE TWO FLAT WASHERS ((ONE) PER CLAMP).
- ITEMS 57 AND 56 ARE USED AS A POSITIVE STOP TO PREVENT PULLING. THE TRANSPORT OUT OF THE CABINET THEY MUST BE INSTALLED WHEN TRANSPORT ASSY IS MOUNTED TO CAB.
- USE BLACK TUBING T. CODE - 36 IN. GROUND STRAP. USE 2 TIE WRAPS (ITEM *52) TO SECURE TUBING TO STRAP.
- USE ONE TIE WRAP TO BIND EXTRA ITEM *51 TO ITEM *45.

- INSERT 5 ITEM *49'S (NOT SHOWN) IN LEFT SIDE, FRONT HOLES NUMBERS 68, 76, 90, 100, AND 106. USE 5 TIE WRAPS (ITEM *52, NOT SHOWN) TO SECURE HARNESS TO CAB. ROUTE CAB FAN HARNESS THRU 861 POWER CONTROL, FAN BOX AND INTO SWITCHED PLUG ON 861 BOX.
- FASTEN TWO ITEM *50'S TO UNDER SIDE OF CAB ROOF AND CAPTIVATE POWER WIRES FROM FAN.
- GROUND STRAP JUMPER FROM TM02 LOGIC BOX TO BE CONNECTED TO POWER SUPPLY TRANS-CAP ASSY.
- FASTEN (ITEM *50) WHERE SHOWN AND SECURE VACUUM MOTOR HARNESS (ITEM *66) USING TIE WRAP (ITEM *52) SECURE HARNESS TO VACUUM HOSE USING TIE WRAPS (ITEM *67) AND CONNECT TO J1 ON POWER BOARD.
- FASTEN (ITEM *50) TO FRONT OF LOGIC ASSY. CHASSIS AND SECURE VACUUM SYSTEM HOSE. HOSE SHOULD NOT COME IN CONTACT WITH COMPONENTS ON REAR OF DECK PLATE.
- USE ONLY ON REAR CHASSIS TRACKS QTY. 4 PER TRACK.
- WITH TRANSPORT FULLY IN CAB LOOSEN CLAMP AT VACUUM ASSY, TWIST HOSE UNTIL HOSE FORMS A SERVICE LOOP ABOVE OR IN PARALLEL WITH VACUUM SYSTEM.
- THIS ITEM MUST BE CONNECTED TO A MAIN VERTICAL UPRIGHT GROUND STAND OFF.

REV.	CHANGE NO.	REV.
1	TU16-00014	D
2	TU16-00015	E
3	TU16-00016	F
4	TU16-00017	G
5	TU16-00018	H
6	TU16-00019	I
7	TU16-00020	J
8	TU16-00021	K
9	TU16-00022	L
10	TU16-00023	M
11	TU16-00024	N
12	TU16-00025	O
13	TU16-00026	P
14	TU16-00027	Q
15	TU16-00028	R
16	TU16-00029	S
17	TU16-00030	T
18	TU16-00031	U
19	TU16-00032	V
20	TU16-00033	W
21	TU16-00034	X
22	TU16-00035	Y
23	TU16-00036	Z
24	TU16-00037	AA
25	TU16-00038	AB
26	TU16-00039	AC
27	TU16-00040	AD
28	TU16-00041	AE
29	TU16-00042	AF
30	TU16-00043	AG
31	TU16-00044	AH
32	TU16-00045	AI
33	TU16-00046	AJ

THIRD ANGLE PROJECTION	REMOVE BURRS AND BREAK SHARP CORNERS	DO NOT SCALE DWG	MATERIAL	FINISH
DRN. V. DUGGAN 8-21-74	CHK'D D. SCHMIDT 9-24-74	ENG. J. BARDONE 9-24-74	PROJ. ENG. BARDONE 9-24-74	PROD. R. GOGUEN 10-2-74
UNLESS OTHERWISE SPECIFIED DIMENSIONS ARE IN INCHES		QUANTITY & VARIATION		
ANGLES 90° 30°	CLASS OF ACCURACY (CHECK ONE)	NOMINAL DIMENSION RANGE INCHES		
SURFACE QUALITY	MEDIUM	0.001	0.002	0.003
MICROMETERS		PREFERRED	0.012	0.015
TITLE		FIRST USED ON		
MAG TAPE DRIVE (TU16)		TU16		
SIZE		CODE		
D		UA		
NUMBER		REV.		
TU15-0-0		M		

"THIS DRAWING AND SPECIFICATIONS HEREIN ARE THE PROPERTY OF DIGITAL EQUIPMENT CORPORATION AND SHALL NOT BE REPRODUCED OR COPIED OR USED IN WHOLE OR IN PART AS THE BASIS FOR THE MANUFACTURE OR SALE OF ITEMS WITHOUT WRITTEN PERMISSION. COPYRIGHT © 1975, DIGITAL EQUIPMENT CORPORATION"

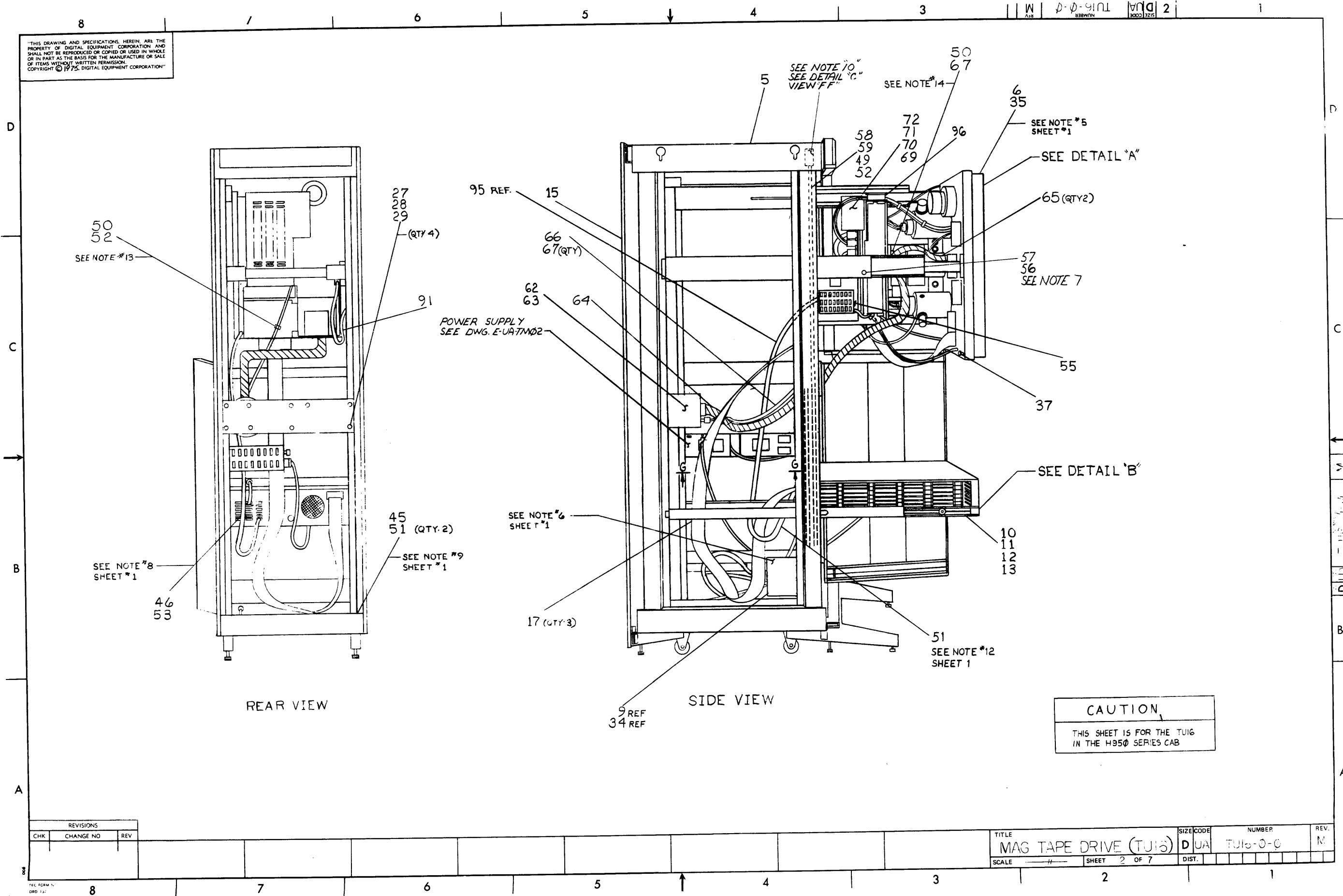

50
52
SEE NOTE #13

SEE NOTE #8
SHEET #1

46
53

45
51 (QTY. 2)

SEE NOTE #9
SHEET #1

27
28
29 (QTY 4)

POWER SUPPLY
SEE DWG. E-UA7M02

SEE NOTE #6
SHEET #1

17 (QTY. 3)

95 REF. 15

66
67 (QTY)

62
63

64

9 REF
34 REF

SEE NOTE #10
SEE DETAIL "C"
VIEW "F"

SEE NOTE #14

58
59
49
52

72
71
70
69

50
67

65
35

SEE NOTE #5
SHEET #1

SEE DETAIL "A"

65 (QTY 2)

57
56
SEE NOTE 7

55

37

SEE DETAIL "B"

10
11
12
13

51
SEE NOTE #12
SHEET 1

CAUTION
THIS SHEET IS FOR THE TU13
IN THE H950 SERIES CAB

REVISIONS		
CHK	CHANGE NO	REV

TITLE	SIZE CODE	NUMBER	REV.
MAG TAPE DRIVE (TU13)	D UA	TU13-0-0	M
SCALE	SHEET	OF	DIST.
	2	7	

"THIS DRAWING AND SPECIFICATIONS, HEREIN, ARE THE PROPERTY OF DIGITAL EQUIPMENT CORPORATION AND SHALL NOT BE REPRODUCED OR COPIED OR USED IN WHOLE OR IN PART AS THE BASIS FOR THE MANUFACTURE OR SALE OF ITEMS WITHOUT WRITTEN PERMISSION. COPYRIGHT © 1974 DIGITAL EQUIPMENT CORPORATION"

CABLE CHART						
ITEM NO	DESCRIPTION	FROM	TO	REMARKS		
54	---	B6 COVER BOX	PLUG	---		
58	---	---	T1-B PT-2	---		
---	---	---	T1-D PT-1	---		
5	---	FAN-1	T1-A ITEM 36	---		
---	---	FAN-2	T1-C ITEM 36	---		
18	---	READ BOARD	HEAD-READ SIDE	---		
20	---	WRITE BOARD	HEAD-WRITE SIDE	SEE DETAIL 'D'		

LOCATION OF "TINNERMAN NUTS" (ITEM #27)	
LOCATE ALL NUTS BY COUNTING HOLES UP FROM BOTTOM OF CABINET UPRIGHT	
FRONT HOLE NUMBERS	REAR HOLE NUMBERS
RIGHT SIDE: 81, 32*, 33*, 103, 104, 105, 106	RIGHT SIDE: 32*, 33*, 53, 60
LEFT SIDE: 81, 32*, 33*, 84, 85, 86, 87	LEFT SIDE: 32*, 33*, 53, 60
LEFT SIDE HOLE NUMBERS FRONT:	RIGHT SIDE HOLE NUMBERS FRONT:
FRONT: 67	FRONT:
REAR: 84, 85, 86, 87	REAR: 7, 103, 104, 105, 106

NOTE:
 * NUMBERS WITH ASTERISKS USED ONLY WHEN TM02 IS USED.

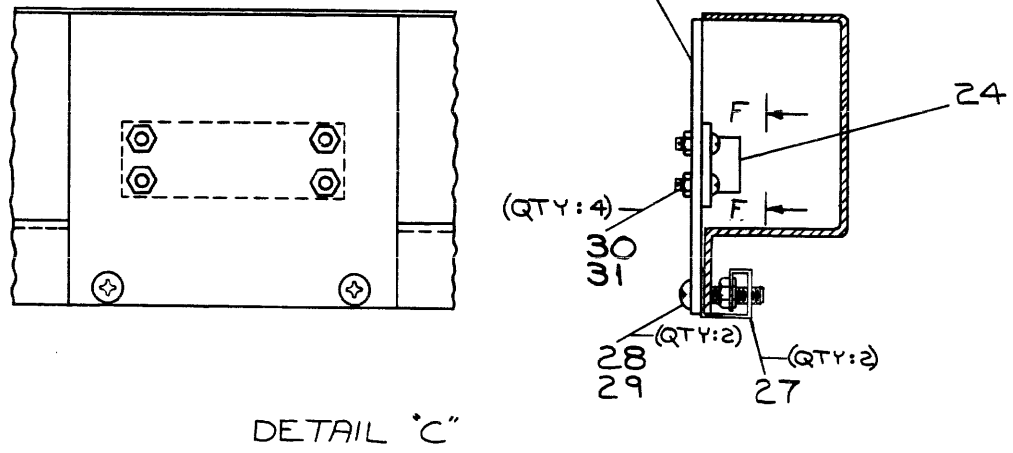
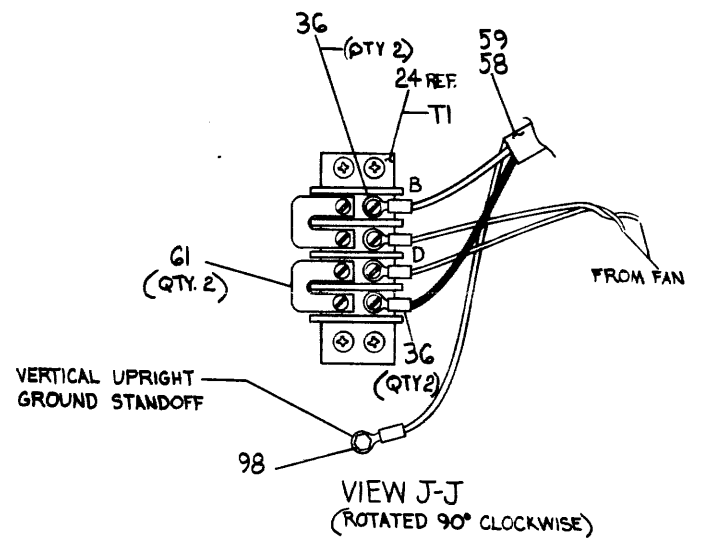
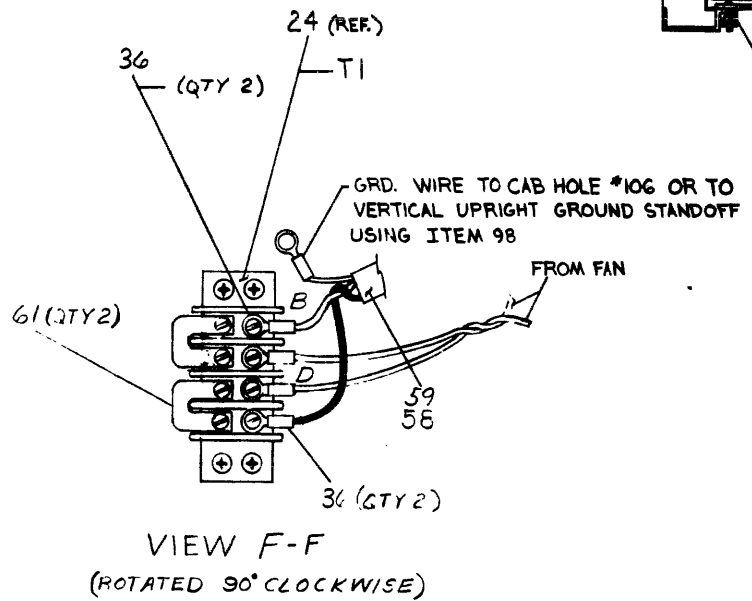
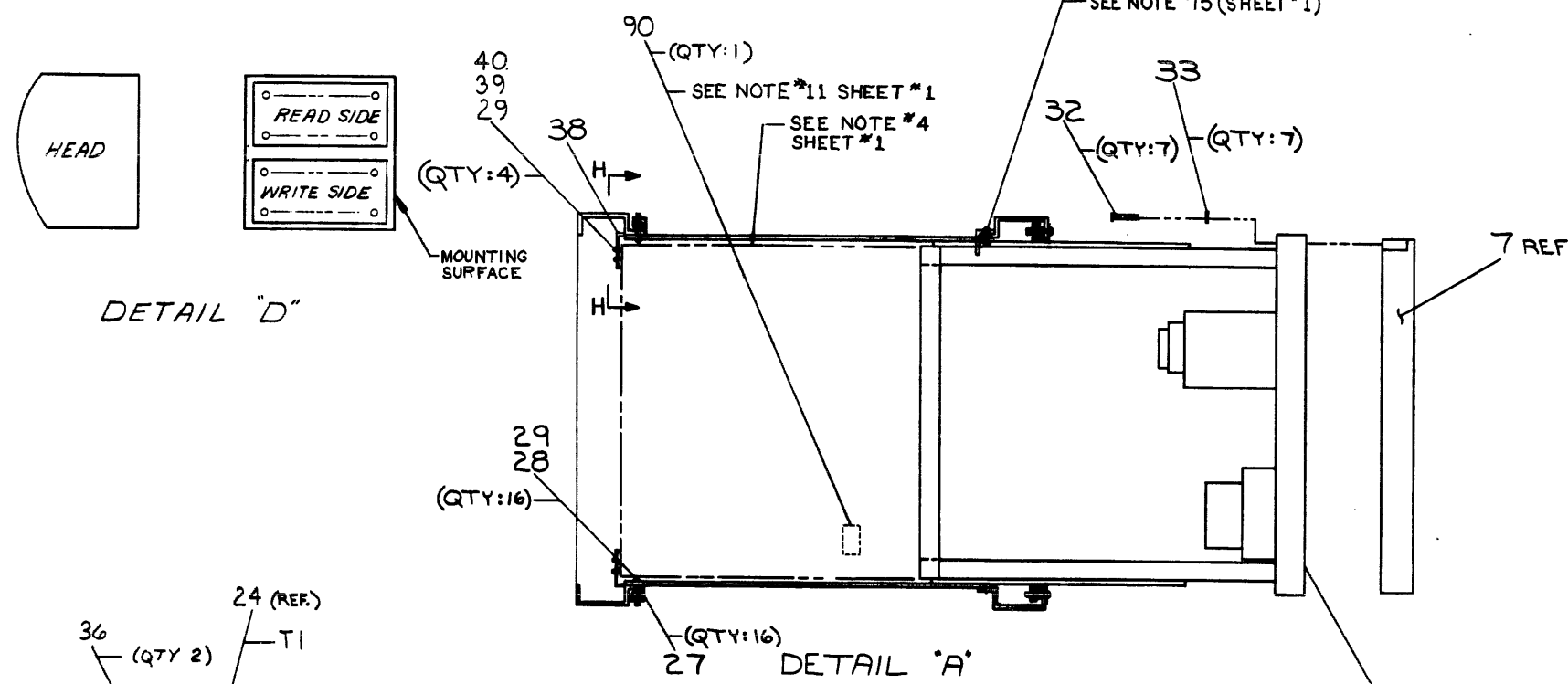

CAUTION
 THIS SHEET IS FOR THE TUIG IN THE H950 SERIES CAB

REVISIONS		
CHK	CHANGE NO.	REV.

"THIS DRAWING AND SPECIFICATIONS, HEREIN, ARE THE PROPERTY OF DIGITAL EQUIPMENT CORPORATION AND SHALL NOT BE REPRODUCED OR COPIED OR USED IN WHOLE OR IN PART AS THE BASIS FOR THE MANUFACTURE OR SALE OF ITEMS WITHOUT WRITTEN PERMISSION. COPYRIGHT © 1974, DIGITAL EQUIPMENT CORPORATION"

DUA TUI6-0-0 2

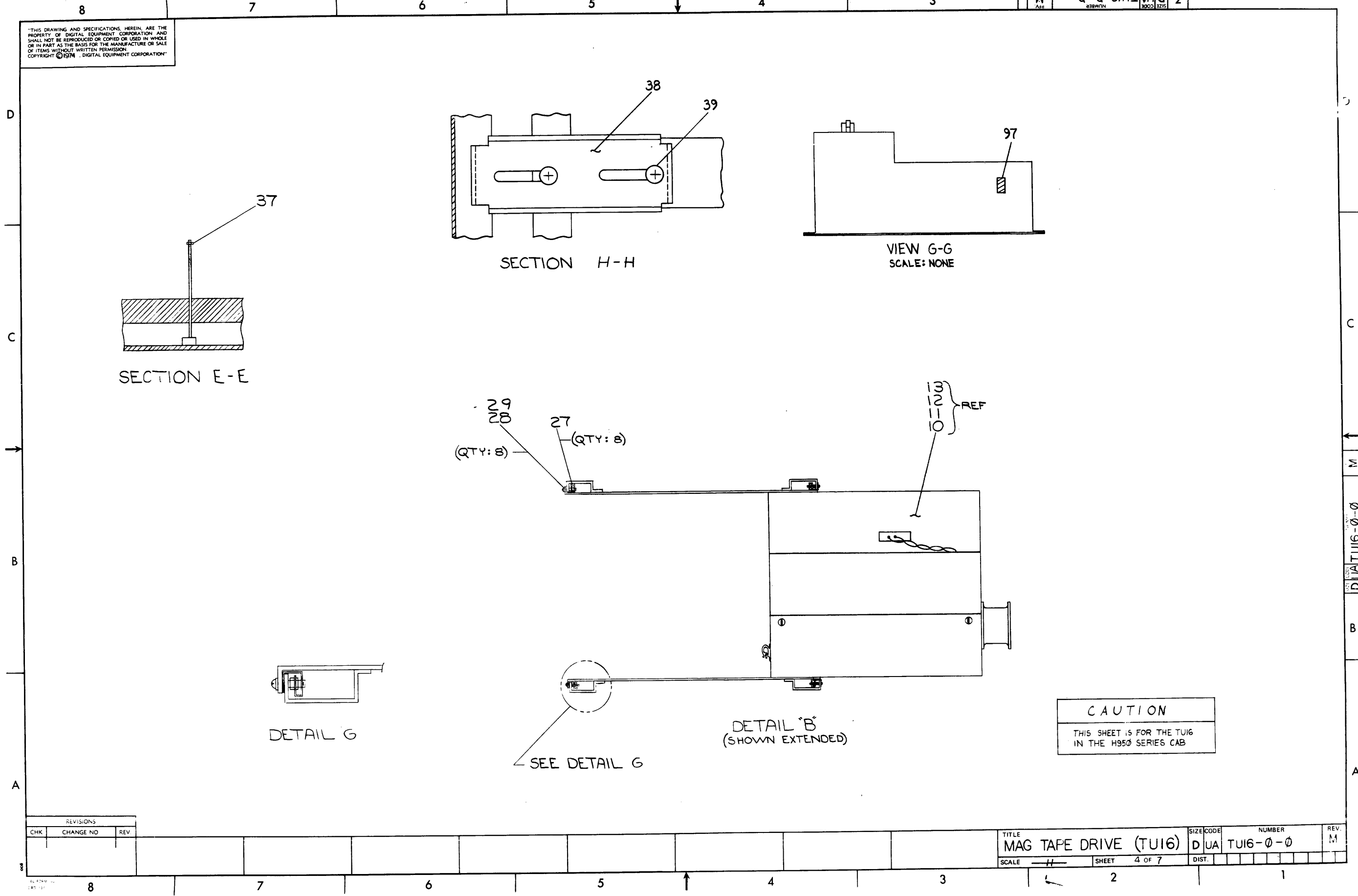

REVISIONS		
CHK	CHANGE NO	REV

TITLE	SIZE CODE	NUMBER	REV
MAG TAPE DRIVE (TUI6)	DUA	TUI6-0-0	M
SCALE	SHEET	DIST.	
1:1	4 OF 7		

THIS DRAWING AND SPECIFICATIONS HEREIN ARE THE PROPERTY OF DIGITAL EQUIPMENT CORPORATION AND SHALL NOT BE REPRODUCED OR COPIED OR USED IN WHOLE OR IN PART AS THE BASIS FOR THE MANUFACTURE OR SALE OF ITEMS WITHOUT WRITTEN PERMISSION. COPYRIGHT © 1970, DIGITAL EQUIPMENT CORPORATION.

W 0-0-91111110 2 1

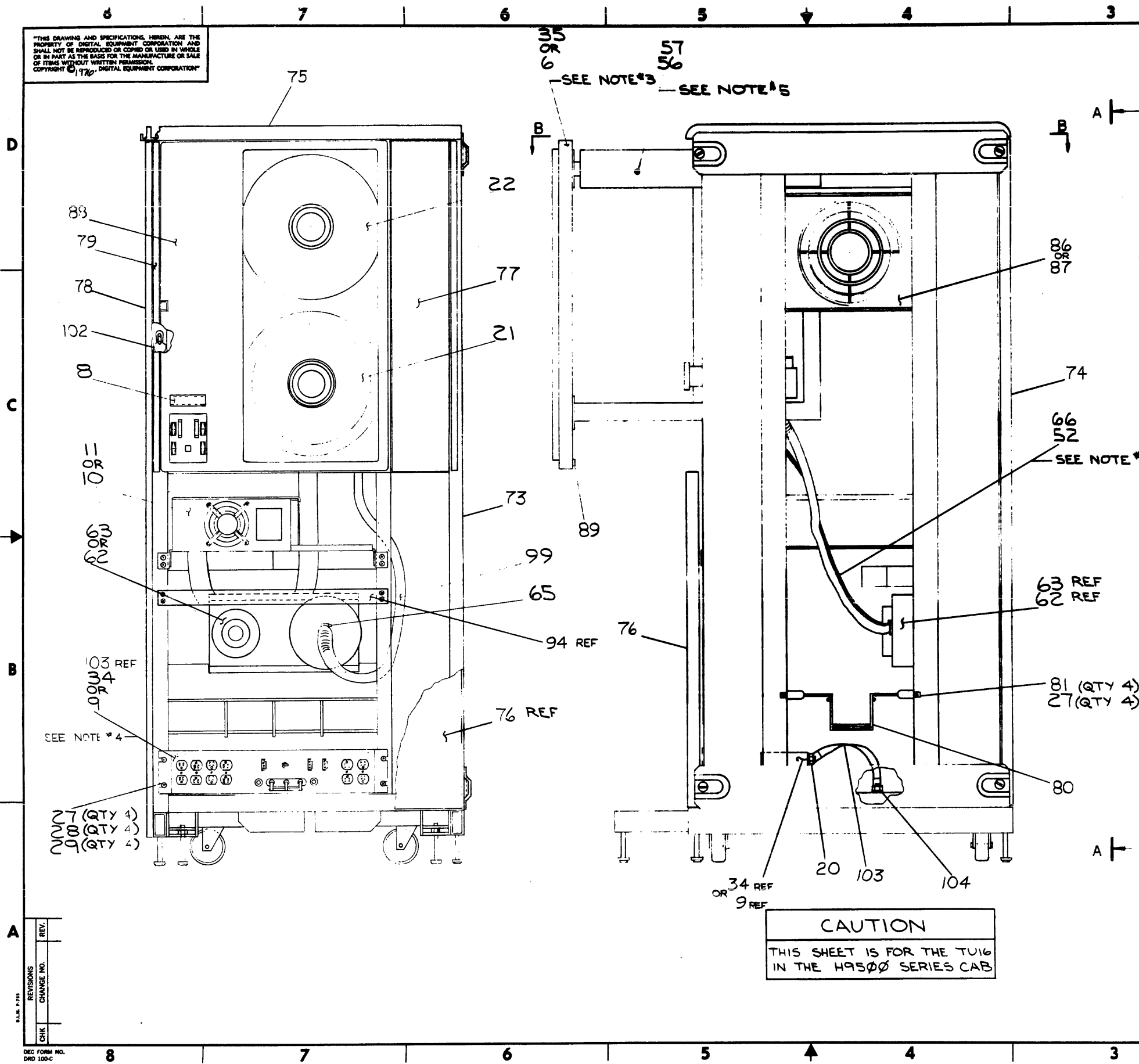

- NOTES:
- FOR INFORMATION ON CONNECTING THE "BC&GR I/O CABLE"(ITEM#17) TO THE TAPE TRANSPORT ASSY (ITEMS#6, #35) REFER TO D-MU-TU16-0-MU.
 - PHANTOM LINES REPRESENT "TAPE TRANSPORT ASSY (ITEMS#6, #35) IN CLOSED POSITION TO SHOW LOCATION OF "SHIPPING BRACKETS"(ITEM #38)
 - TO CONVERT FROM 120 TO 240 VAC OPERATION, CUT MALE END FROM TU16'S POWER CORD, THEN CONNECT THE CORD TO "240 VAC MALE CONN." (ITEM#43, NOT SHOWN).
 - POWER CORD ROUTING FOR:
861 POWER CONTROL - "CABLE CLAMP"(ITEM #42 NOT SHOWN), "TINNERMAN NUT"(ITEM #27) "PHL TRUSS HD SCREW"(ITEM #28) AND "KEP NUT"(ITEM #29) TO MOUNT ON RIGHT SIDE REAR HOLE #10, ROUT CORD THRU CABLE CLAMP AND OUT THE BOTTOM OF CABINET.
TU16 - ROUTE CORD THRU "CABLE CLAMP"(ITEM#54, NOT SHOWN) SECURED WITH THE ABOVE HARDWARE, LOCATE ON THE LEFT SIDE FRONT HOLE #67, OUTSIDE OF CHASSIS SLIDE AND INTO PLUG ON 861.
 - "HEX HD SCREW"(ITEM#56) AND "KEP NUT"(ITEM#52) ARE USED AS A POSITIVE STOP TO PREVENT PULLING THE "TAPE TRANSPORT ASSY (ITEMS#6, #35) OUT OF THE CAB AND MUST BE INSTALLED WHEN THE "TAPE TRANSPORT" IS MOUNTED TO CAB.
 - USE "BLK EXTRUDED TUBING"(ITEM#53) TO COVER "38 IN GROUND STRAP"(ITEM#46) AND USE 2 "CABLE TIES"(ITEM#52, NOT SHOWN) TO SECURE TUBING TO STRAP.
 - GROUND STRAP JUMPER FROM TM02 LOGIC BOX TO BE CONNECTED TO GROUND LUG AT BOTTOM OF BASE CAB.
 - SECURE "VACUUM MOTOR HARNESS"(ITEM#66) TO "HOSE"(ITEM#99) AND CONNECT HARNESS TO J1 ON THE POWER BOARD.
 - INSTALL "TINNERMAN NUT"(ITEM#27) INTO HOLES #76 & #77 ON THE RIGHT FRONT SIDE OF CAB AND MOUNT "STOP BRACKET"(ITEM#63) AS SHOWN.
 - REMOVE HEX HD. CAP SCREW IN FRAME ASSY. (ITEM #73) TO ASSEMBLE COUNTERWEIGHT LEAD, (ITEM #100) + BRK'T COUNTERWEIGHT (ITEM #101) TO FRAME ASSY.

CAUTION
THIS SHEET IS FOR THE TU16
IN THE H9500 SERIES CAB

QUANTITY & VARIATION	DESCRIPTION	DWG./PART NO.	ITEM NO.
	UNLESS OTHERWISE SPECIFIED DIMENSIONS ARE IN INCHES		
	ANGLES 30° 30'	CLASS OF ACCURACY (CHECK ONE)	NOMINAL DIMENSION RANGE INCHES
			OPEN 0 TO 0.2
			OVER 0.2 TO 1.2
			OVER 1.2 TO 4.0
			OVER 4.0 TO 12.0
			OVER 12.0 TO 40.0
			OVER 40.0 TO 80.0
	SURFACE QUALITY IN		
	MEDIUM	±.004	±.008
		±.012	±.016
		±.024	±.04
		±.08	±.16
	MICROINCHES	PREFERRED	±.012
			±.016
			±.025
			±.04
			±.063
			±.1
THIRD ANGLE PROJECTION	DRM. M. DL'GGAN 8-21-74	FIRST USED ON	TU16
REMOVE BURRS AND BREAK SHARP CORNERS	CHK'D. D. SCHMIDT 9-24-74	TITLE	MAG TAPE DRIVE (TU16)
DO NOT SCALE DWG	ENG. J. BAIRDONE 9-24-74	SCALE	NONE
MATERIAL	PRQJ. ENG. BARDONE 9-24-74	SIZE CODE	B-DD-TU16-0
FINISH	PROD. R. GOGUEN 10-2-74	SCALE	NONE
	NEXT HIGHER ASSY.	NUMBER	TU16-0-0
		REV.	M
		DIST.	

REVISIONS
CHANGE NO.
REV.

DEC FORM NO. DRD 100-C

"THIS DRAWING AND SPECIFICATIONS HEREIN ARE THE PROPERTY OF DIGITAL EQUIPMENT CORPORATION AND SHALL NOT BE REPRODUCED OR COPIED OR USED IN WHOLE OR IN PART AS THE BASIS FOR THE MANUFACTURE OR SALE OF THINGS WITHOUT WRITTEN PERMISSION. COPYRIGHT © 1972 DIGITAL EQUIPMENT CORPORATION"

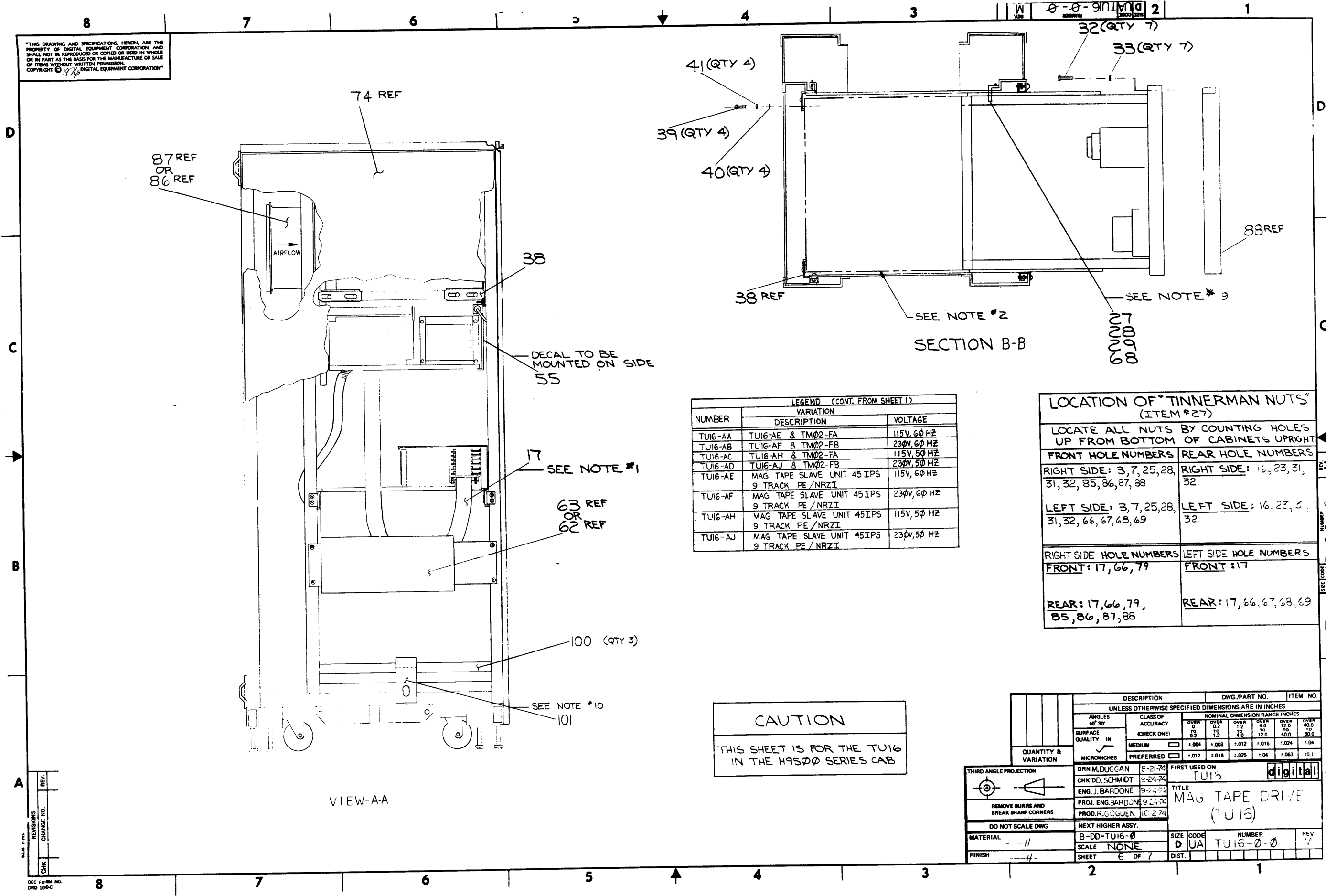

DECAL TO BE MOUNTED ON SIDE 55

SEE NOTE #1

SEE NOTE #10

41 (QTY 4)

39 (QTY 4)

40 (QTY 4)

38 REF

27
28
29
68

SEE NOTE #2

SECTION B-B

SEE NOTE #3

LEGEND (CONT. FROM SHEET 1)		
NUMBER	VARIATION	VOLTAGE
TU16-AA	TU16-AE & TM02-FA	115V, 60 HZ
TU16-AB	TU16-AF & TM02-FB	230V, 60 HZ
TU16-AC	TU16-AH & TM02-FA	115V, 50 HZ
TU16-AD	TU16-AJ & TM02-FB	230V, 50 HZ
TU16-AE	MAG TAPE SLAVE UNIT 45 IPS 9 TRACK PE/NRZI	115V, 60 HZ
TU16-AF	MAG TAPE SLAVE UNIT 45 IPS 9 TRACK PE/NRZI	230V, 60 HZ
TU16-AH	MAG TAPE SLAVE UNIT 45 IPS 9 TRACK PE/NRZI	115V, 50 HZ
TU16-AJ	MAG TAPE SLAVE UNIT 45 IPS 9 TRACK PE/NRZI	230V, 50 HZ

LOCATION OF *TINNERMAN NUTS* (ITEM #27)	
LOCATE ALL NUTS BY COUNTING HOLES UP FROM BOTTOM OF CABINETS UPRIGHT	
FRONT HOLE NUMBERS	REAR HOLE NUMBERS
RIGHT SIDE: 3, 7, 25, 28, 31, 32, 85, 86, 87, 88	RIGHT SIDE: 16, 23, 31, 32
LEFT SIDE: 3, 7, 25, 28, 31, 32, 66, 67, 68, 69	LEFT SIDE: 16, 23, 31, 32
RIGHT SIDE HOLE NUMBERS	LEFT SIDE HOLE NUMBERS
FRONT: 17, 66, 79	FRONT: 17
REAR: 17, 66, 79, 85, 86, 87, 88	REAR: 17, 66, 67, 68, 69

CAUTION
THIS SHEET IS FOR THE TU16 IN THE H9500 SERIES CAB

QUANTITY & VARIATION	DESCRIPTION	DWG. PART NO.	ITEM NO.					
				UNLESS OTHERWISE SPECIFIED DIMENSIONS ARE IN INCHES				
THIRD ANGLE PROJECTION	ANGLES	CLASS OF ACCURACY	NOMINAL DIMENSION RANGE INCHES					
	SURFACE QUALITY	(CHECK ONE)	OVER 0 TO 0.2	OVER 0.2 TO 1.2	OVER 1.2 TO 4.0	OVER 4.0 TO 12.0	OVER 12.0 TO 40.0	OVER 40.0 TO 80.0
REMOVE BURRS AND BREAK SHARP CORNERS	MEDIUM	<input type="checkbox"/>	±.004	±.008	±.012	±.016	±.024	±.04
DO NOT SCALE DWG	PREFERRED	<input checked="" type="checkbox"/>	±.012	±.016	±.025	±.04	±.063	±0.1
MATERIAL	DRN. M. DUCCAN	6-21-74	FIRST USED ON	TU16				
FINISH	CHK'D. D. SCHMIDT	9-24-74	TITLE	MAG TAPE DRIVE (TU16)				
	ENG. J. BARDONE	9-24-74						
	PROJ. ENG. BARDONE	9-24-74						
	PROD. R. GOGUEN	10-2-74						
	NEXT HIGHER ASSY.							
	SCALE	NONE	SIZE	CODE	NUMBER	REV		
	SHEET	6 OF 7	D	UA	TU16-0-0	M		

REV.	CHANGE NO.

DEC FORM NO. DRG 100-C

