

DICK BAILEY

digital

MAINTENANCE CARD

RL 01

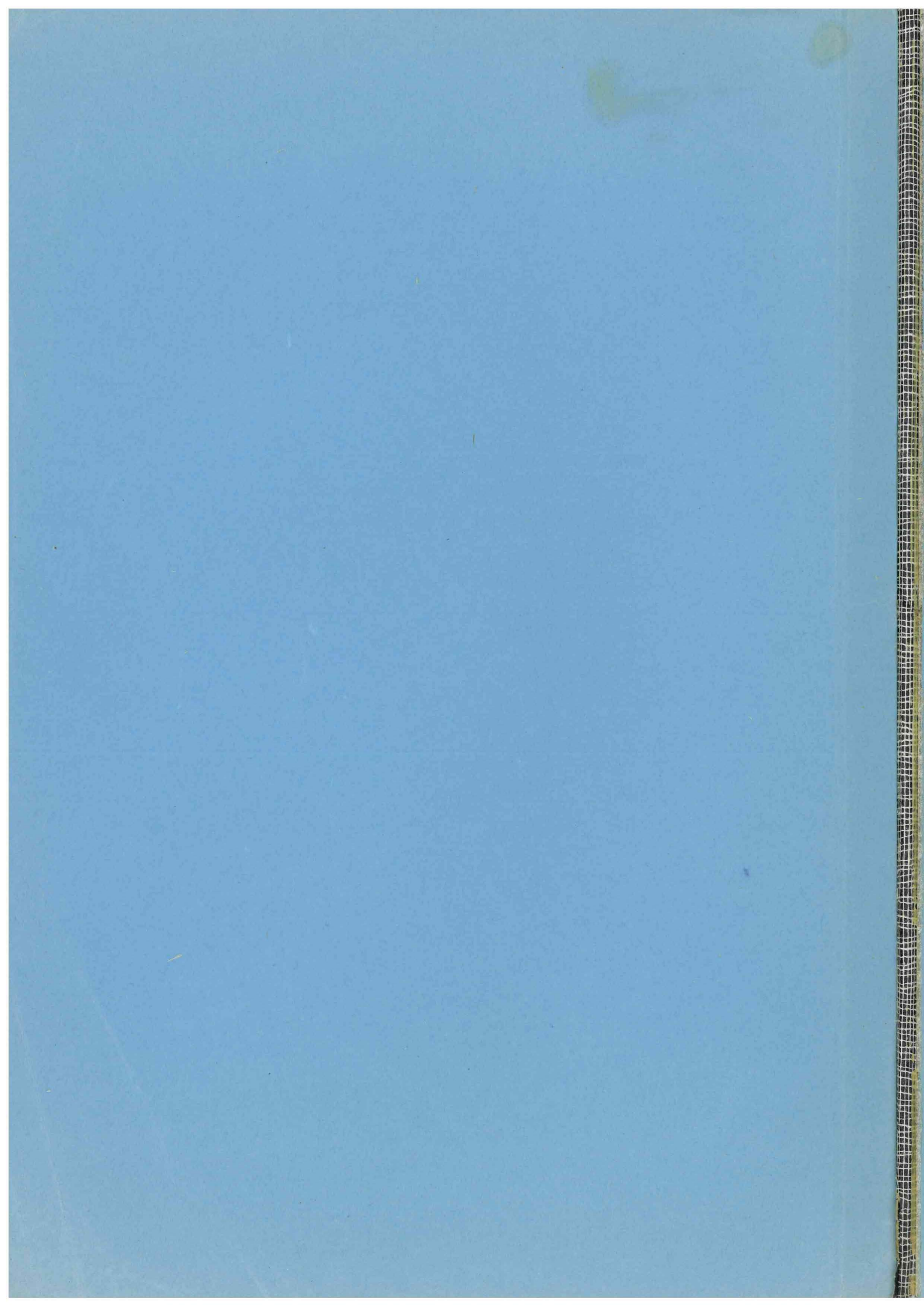

digital

EK-RL01-PG-PRE

RL DISK SUBSYSTEM
MAINTENANCE HANDBOOK

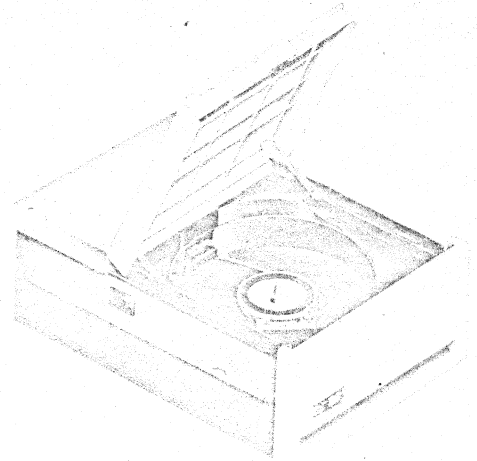

1st Edition, December 1977
2nd Printing (Rev), January 1978
3rd Printing (Rev), February 1978
4th Printing (Rev), March 1978
5th Printing (Rev), August 1978

Copyright© 1977, 1978 by Digital Equipment Corporation

The material in this manual is for informational purposes and is subject to change without notice.

Digital Equipment Corporation assumes no responsibility for any errors which may appear in this manual.

Printed in U.S.A.

DEC	DECtape	PDP
DECCOMM	DECUS	RSTS
DECsystem-10	DIGITAL	TYPESET-8
DECSYSTEM-20	MASSBUS	TYPESET-11
	VAX	UNIBUS

Maintenance Handbook

Table of Contents

Revision/copyright page	i
Table of Contents	ii
Table of Contents	iii
I. General Information	
Specifications chart	1
Sector format block diagram	2
Module usage block diagram	3
Functional description of modules	4
Illustration of operator control panel	5
Description of logic signals that cause front panel lamps to light	6
II. How to access drive modules	
Drive Logic Module, A.C. servo, D.C. servo and R/W	7
A.C. servo module cabling illustration	9
R/W module shown ready for servicing ..	10
Drive Logic Module cabling illustration ..	11
D.C. Servo Module cabling illustration ..	12
III. RL11/RLVII Register Summary	
Control and Status	13
Bus Address	14
Disk Address (seek mode)	14
Disk Address (R/W and Get Status modes) ..	15
Multiple Purpose (Get status mode)	16
Multiple Purpose (Read Header and Word Count modes)	17
IV. Programming an RL01 — RL11/RLVII Subsystem	
Programming Information	18
Sample Programming Steps	19
Example Oscillating Seek Routine	21
Example R/W program	22

V. Block Diagrams	
RL01 Servo Data Format	23
Servo Data Signal Generation	24
M7762 RL11 Basic Block	25
RL Drive Block	26
VI. Servicing Section	
A. Miscellaneous	
RL01 Toggle Boot Loader	27
Field Replaceable Unit List	27
PM Schedule	29
Servicing Tips	29
Observation of Drive Errors With O'scope	32
B. Drive Checks and Adjustments	
Grounding	33
Voltage	33
Sector Transducer Output	33
Sector Pulse Timing Check	34
Read Signal Amplitude Check	34
Positioner Radial Alignment	37
Illustration of Drive Logic Module Test Points	39
Head Alignment	41
Spindle Runout Check	45
Position Signal Gain Check	47
Tachometer A.C. Noise Pick-up Check	48
Velocity Profile Check	49
Servo Drive Motor Current Check	50
Access Time Check	51
VII. RL01-RL11/RLVII Diagnostic Summary	
General	53
RLA	53
RLB	55
RLC	57
Description of Head Alignment Routine	58
RLD	59
RLE	60
RLF	61

SPECIFICATIONS

- Capacity of one RL01K cart = 5MBYTES
- 2 surfaces, 0 (upper) and 1 (lower)
- 256 tracks/surface
- 40 sectors/track
- 128 16-bit words/sector
- Max. bit density = 3725 BPI
- Track-to-track spacing = .008"
- Data encoding method = M.F.M. (PRE-COMPENSATED)
- Bit cell width (time) = 244NSEC
- VCO rate = 8.2M~
- Data transfer rate = 3.9 μ SEC/word
- Spindle motor speed = 2400 R.P.M.
- Seek time: Max = 100MSEC
Min = 15MSEC
- Positioner = D.C. motor and capstan
- Positioner control = track-following
Servo system incorporating
Servo-in-data concept
- Headers are factory formatted with servo data. No
in-field formatting
- Load heads time = 40SEC (approx.)
- Stop time = 30SEC (approx.)
- Weight of drive = 75 lb. (34KG.)
- Drive power req. = 95-128VAC @ 47-63~ Connector
or 180-256VAC @ 47-63~ on back to
change
- Media required = DEC RL01K
- Cartridges must be used at room temp. only Seeks large
with temp
rise?
- Drives/controller = 4
- Max. cable length = 100'
- RL11 controller = M7762 (small periph. controller-
type module)
- RLV11 controller = M8013 & M8014

- Priority level of interrupts = 5
- Interrupt vector = 160 *not 330.*

SECTOR FORMAT

Servo in this period.

Sector pulse gap i.e. 2400 μ sec

Servo pulse period

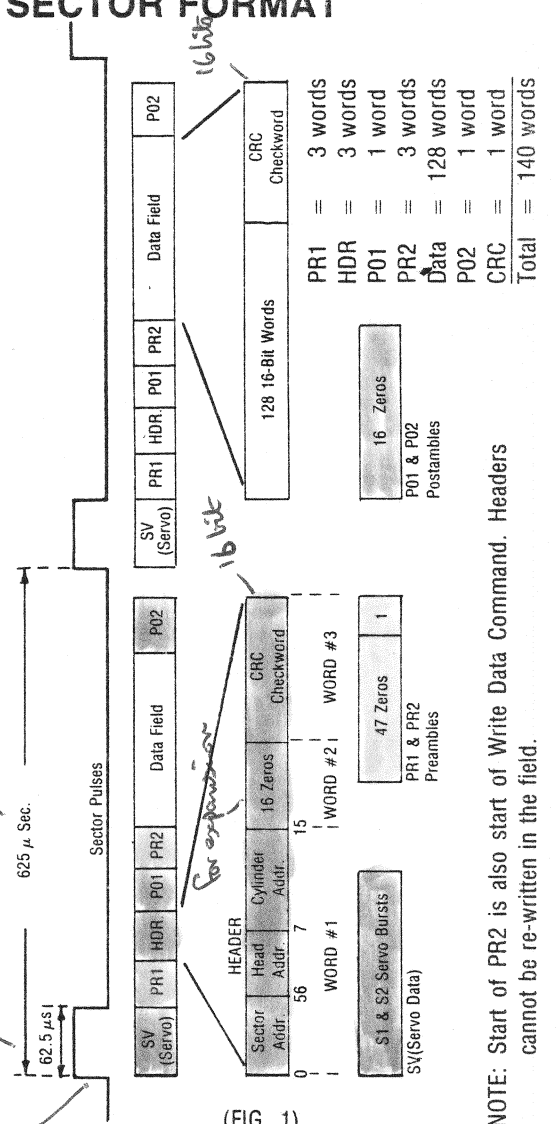

(FIG. 1)

NOTE: Start of PR2 is also start of Write Data Command. Headers cannot be re-written in the field.

RL01 MODULE FUNCTIONS

Counts pulses to 400000

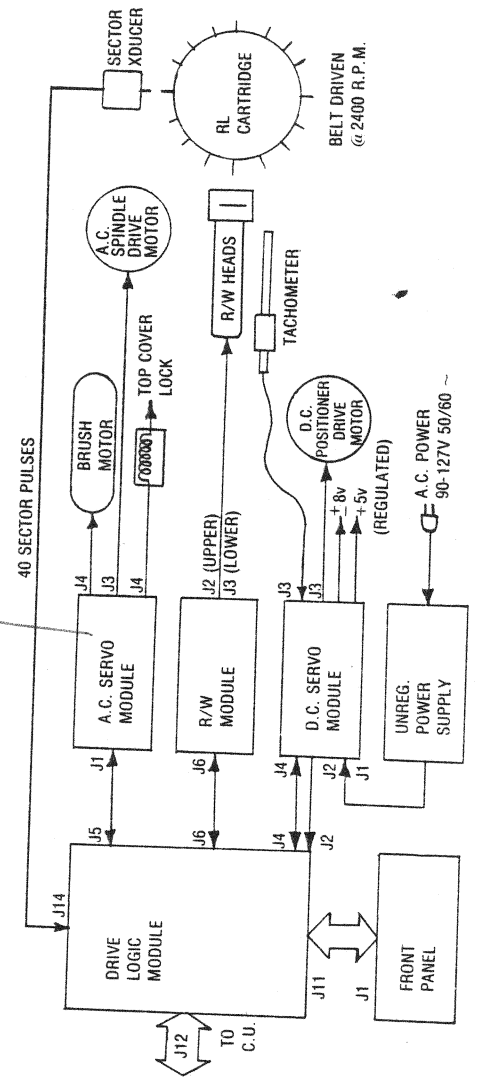

(FIG. 2)

MODULE FUNCTIONS

- A. Drive Logic Module (located inside rear field service access cover)
1. Major state control (power-up and head load sequencing)
Drawing number 5412175 Page DL1
 2. Control & status register Page DL2
 3. Seek control & track count ckts. Page DL3
 4. Disk motor speed control Page DL4
 5. Error detection Page DL5
 6. Controller interface logic Page DL6
 7. Servo data interpretation Page DL7
 8. Sector pulse generation Page DL8
- B. D.C. Servo Module (located at right rear corner of drive, directly over power supply)
1. D.C. voltage regulation
Drawing number 5411850 Page 1 of 2
 2. Final drive to positioner D.C. motor (servo power amp) Page 1 of 2
- C. A.C. Servo Module (located at left rear corner of drive, behind spindle drive motor)
- Drawing number 5411848
1. Brush motor control
 2. Spindle drive motor control
 3. Top cover locking solenoid control
- D. R/W Module (located directly over positioner)
1. Data preamplifier (both customer and servo data)
Drawing number 5411844 Page 1 of 2
 2. Head selection (0 up, 1 down) Page 1 of 2
 3. Write current drivers Page 1 of 2
 4. Error detection circuits (for writing) Page 1 of 2

FRONT PANEL LIGHTS

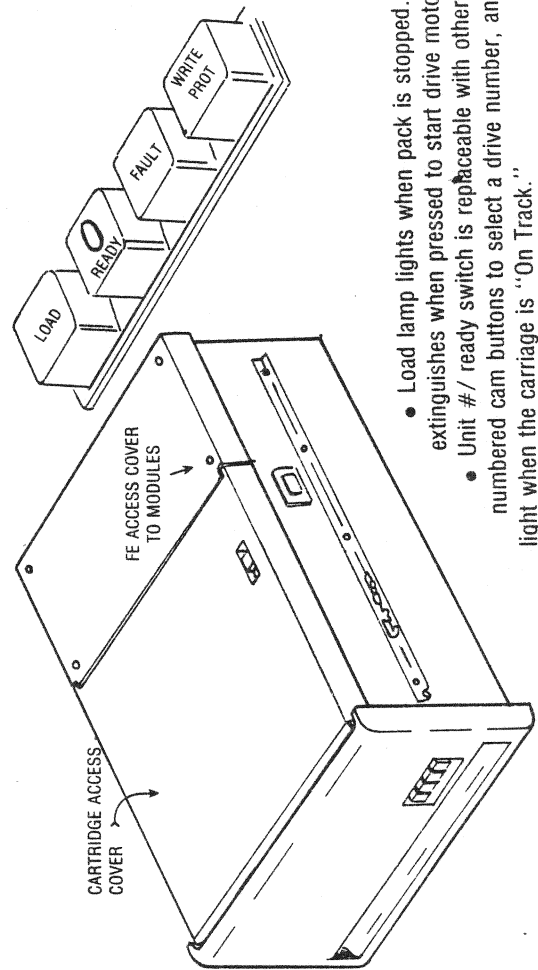

- Load lamp lights when pack is stopped. It extinguishes when pressed to start drive motor.
- Unit # / ready switch is replaceable with other numbered cam buttons to select a drive number, and will light when the carriage is "On Track."

(FIG. 3)

WRITE PROTECT lamp lights when depressed inhibiting write operations.

NOTE: Write protection will only occur if *not* presently engaged in a write operation.

FAULT Lamp lights with one or more of the following errors asserted:

WRITE Gate — WRITE Gate was asserted while drive was WRITE PROTECTED, or "READY TO READ/WRITE" was not asserted, or drive is in the midst of sector pulse time, or the drive has another error asserted.

SEEK TIME OUT — The timer on "Ready to Read/Write (on track) indicated that the Seek operation took too long, or, "Ready to Read/Write" was lost while in "lock-on" (position) mode of operation.

SPIN — Disk failed to come up to speed within 39 sec. or, disk is overspeeding.

DRIVE SELECT ERROR — More than one drive has the same unit number.

CURRENT IN HEADS — Write current was detected flowing without WRITE Gate being asserted.

CLOCK — System clock (from controller) was detected missing.

WRITE DATA — WRITE Gate is asserted, but no write data transition occurred before time-out.

THE FAULT lamp can only be cleared by powering the drive down by way of the circuit breaker at the rear of the drive OR by issuing a software "GET STATUS" command (code of 2. C.S.R.) with bits 0, 1, and 3 set in the D.A.R. (Bit 3 will reset the error latches).

The exception is the CLOCK Error. It is not latched and will go away only when a CORRECT CLOCK is received from the controller.

NOTE: See servicing tips section for scope test points of these errors on page 32.

RL MODULES: THEIR PLACEMENT AND ACCESSIBILITY

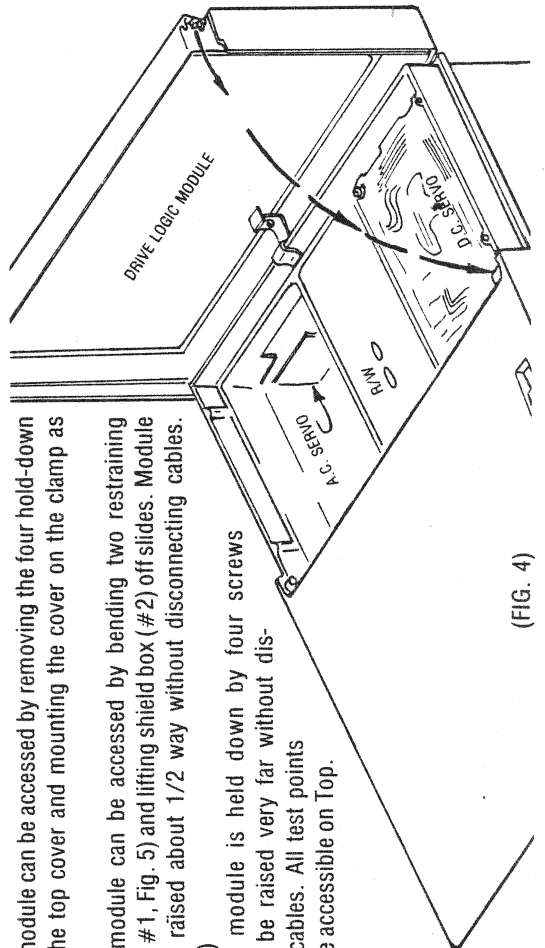

(FIG. 4)

1. Drive logic module can be accessed by removing the four hold-down screws on the top cover and mounting the cover on the clamp as shown.
2. A.C. servo module can be accessed by bending two restraining clamps (See #1, Fig. 5) and lifting shield box (#2) off slides. Module can now be raised about 1/2 way without disconnecting cables. (See Fig. 6.)
3. D.C. servo module is held down by four screws and cannot be raised very far without disconnecting cables. All test points however, are accessible on Top.

4. R/W module requires some extra caution when gaining accessibility. Lift the module out of the casting and seat on the two extensions of the casting. (See #1, Fig. 7) two test points are accessible through cut-outs in the cover. If the module needs to be removed from the shield casing, the four plastic tabs must be very carefully pulled aside to lift the cover out of the way. (See #2, Fig. 7)

AC SERVO MODULE SHIELD COVER AND SLIDES

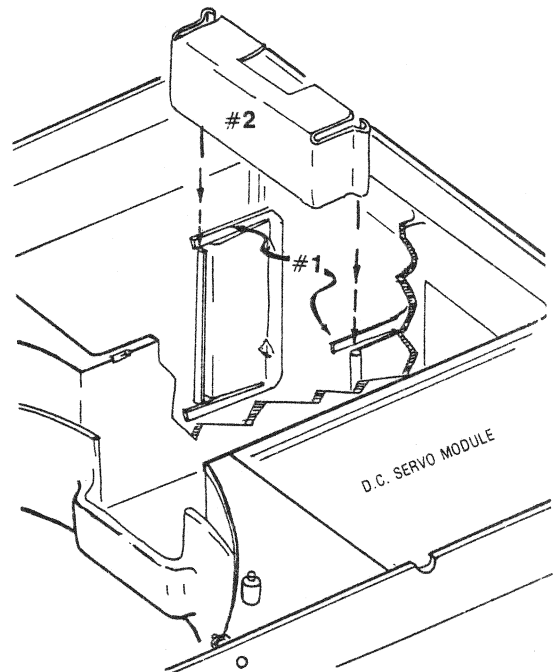

(FIG. 5)

AC SERVO MODULE CABLES

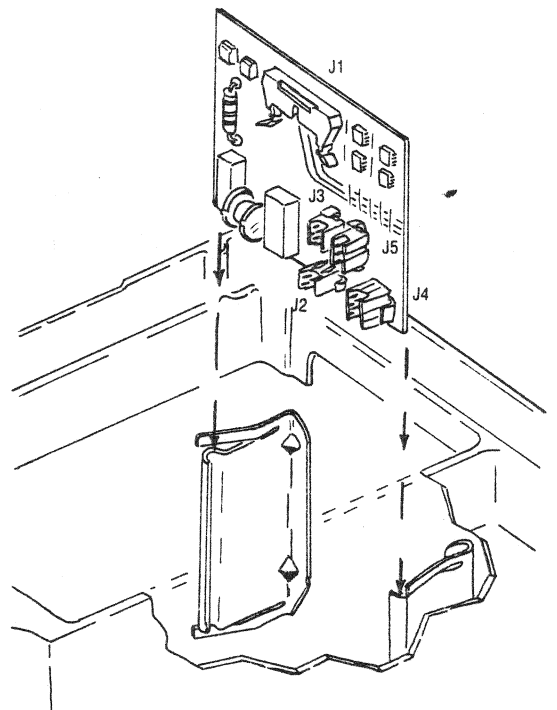

- J1 — From Drive logic module
- J2 — Motor start capacitor
- J3 — Spindle drive motor
- J4 — Brush motor
- J5 — AC power from power supply

(FIG. 6)

ILLUSTRATION SHOWING R/W MODULE & SUPPORT DOWELS ON CASTING

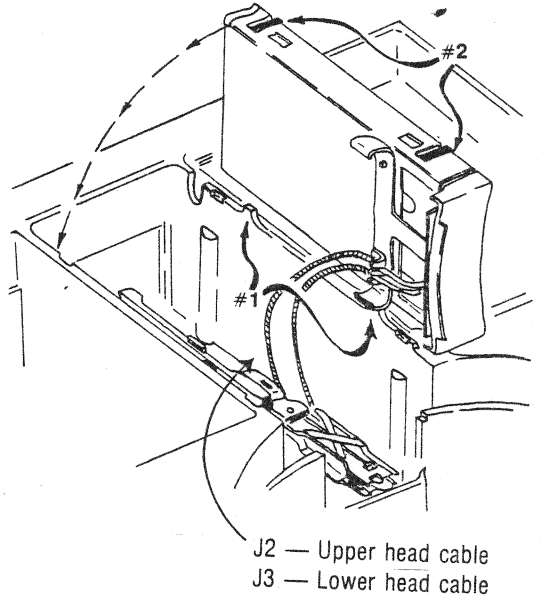

NOTE: Head Cables must be secured into retaining clip as illustrated to ensure unrestricted carriage movement.

(FIG. 7)

DRIVE LOGIC MODULE CABLES

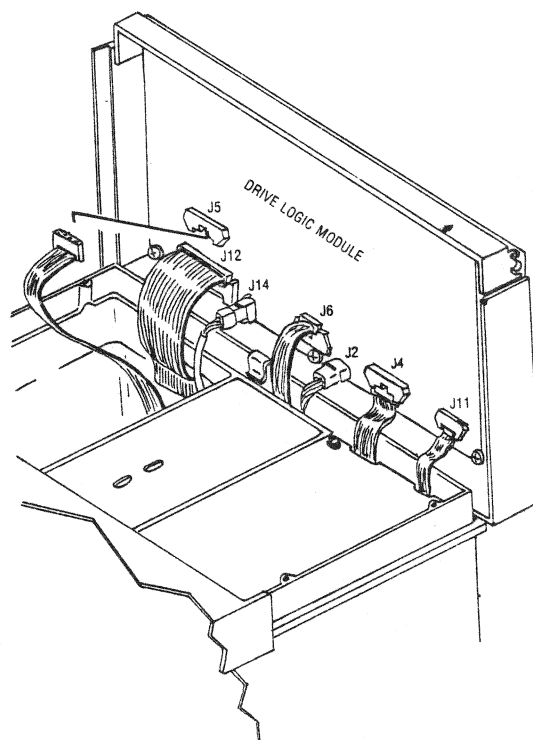

- J5 — From AC Servo
- J12 — From controller
- J14 — From sector xducer
- J6 — From R/W module
- J2 — Power from D.C. servo
- J4 — From D.C. servo
- J11 — From front panel switches

(FIG. 8)

DC SERVO CABLES

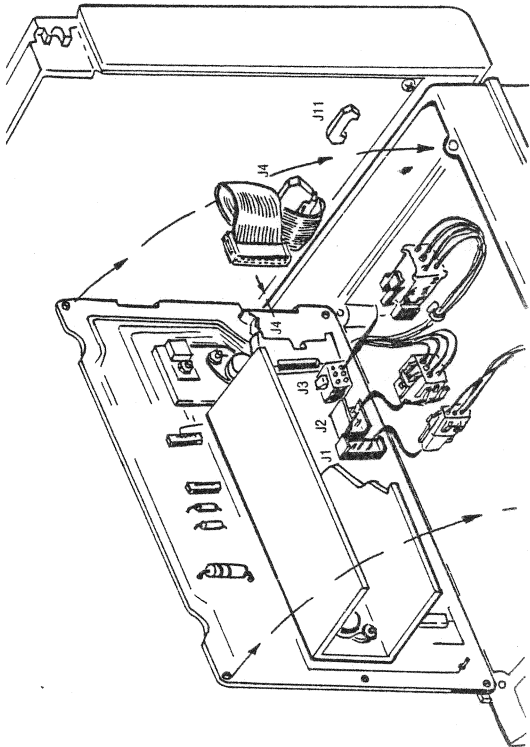

- J1 — From power supply
- J2 — Power to drive logic module
- J3 — Signals from baseplate
- J4 — To drive logic module

(FIG. 9)

RLII/RLVII REGISTER SUMMARY

The RL01 subsystem has four (4) base register addresses for software accessing. Two (2) of these are multiple purpose in nature so as to allow the accessing of eight (8) registers with the four (4) addresses.

I. Control and Status 774400

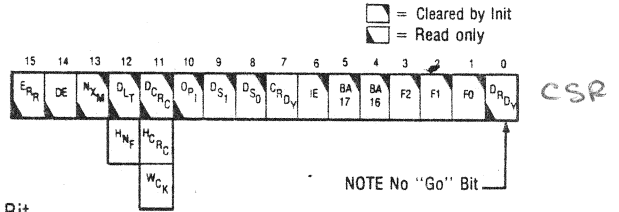

Bit

0 = Drive Ready

1 } = Function Code → No-Op 0 **RESET**
 2 } Write Check 1

Extended Get Drive Status 2

4 } = Bus Addr. Seek 3

5 } = Bits for 18 Bit Read Header 4

Memory Addr. Write Data 5 } **NO IMPLE**

6 = Interrupt Enable Read Data 6 } **SEEK**

7 = Controller Ready Read Data

(Writing a Zero Without header

into this position Compare 7

when bit is asserted

is the new "GO"

command.)

8 } = Drive Select Code in Binary 0-3

9 } Error Code → **OPERATION INCOMPLETE** 12 11 10

10 } OPI Error 0 0 1

11 } Read Data CRC ERR 0 1 0

Write check ERR 0 1 0

Header CRC ERR 0 1 1

Data Late ERR 1 0 0

Header not found 1 0 1

- 13 = Non-existent memory (20 μ sec ssyn time-out occurred)
- 14 = Drive error (use the "get status" command to find which error occurred.)
- 15 = composite error (one or more of bits 10 thru 14 are set in this register.)

NOTE: Unibus Init clears bits 1-6 and 8-13 while setting bit 7

Clear bit 7 to commence operations

II. Bus. address register 774402

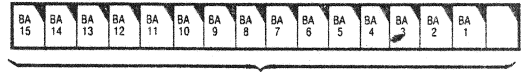

BAR

0 = must be a zero
 1 } Loaded with the 1st memory location
 ↓ the N.P.R.'s are to take place from
 15 } *2 extension bits in CSR*

III. Disk address register 774404

3 purpose register:

- A. Seeks — Sends cyl. difference to drive.
- B. Reading or writing data — holds current disk address value for comparing headers.
- C. Get status — Part of software command to get RL01 to send status.

A. Seeks

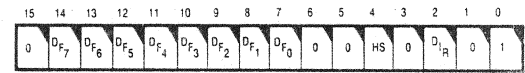

DAR

Loaded with difference

- 0 = Must be a one (RL01 uses it to tell when the seek command is shifted to the drive. [marker])
- 1 = Must be a zero to tell the drive that this information pertains to seeks.
- 2 = Direction of seek. (1 = FWD)
- 3 = Must be a zero.

S/W must monitor where we are.

- 4 = Head select bit (1 = lower head [#1])
- 5 } Reserved for future use.
- 6 }
- 7 }
- 14 } Cylinder address difference
- 15 = Must be a zero

B. Reading or Writing Data

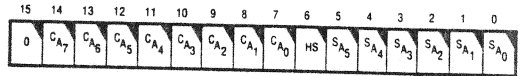

- 0 } Sector Address
- 5 }
- 6 = Head Select Bit (1 = lower head)
- 7 } Cylinder address
- 14 }
- 15 = Must be a zero

C. Get Status Commands

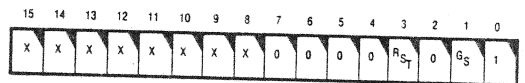

- 0 = Must be a one (RL01 uses it to tell when the get status comm. is shifted to the drive. [Marker Bit])
- 1 = Get status bit. (Must be a one to command the RL01 to get its status and send it to the M.P. register.)
- 2 = Must be a zero.
- 3 = Reset bit. (1 = a command to the RL01 to clear the drive's errors before sending the status to the M.P. register.)
- 4 } Must be zeros
- 7 }
- 8 } Ignored
- 15 }

*3 Don't reset error when getting serial status word.
138 Do reset.*

A Holds Status word
 after DAR & CSR used
 for a get status command

- IV. M.P. (Multiple purpose register) 774406
 3 purpose register that can contain 5 different words of information dependent upon the function being performed.
- A. Results of Get Status Command
 - B. 3 words of the header during a read header command.
 - C. Word count during a Data transfer command.

A. Get Status

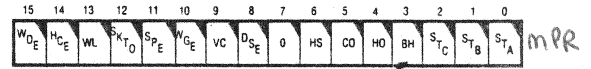

Bit				
0	} Status Code →	Load Disk	= 0	0 0
1		Spin Up	= 0	0 1
2		Brushes Home	= 0	1 0
3		Brush cycle	= 0	1 0
		Load Heads	= 0	1 1
4		Seeking	= 1	0 0
		(course servo)		
5		Lock on	= 1	0 1
		(fine servo)		
		Unload heads	= 1	1 0
		Spin down	= 1	1 1
		Dynamic braking mode)		
6		Head Select Code (1 = Lower head)		
7		Must be a zero		
8		Drive select error (multiple drives sensed with same unit number)		
9		Volume check (1 = drive was turned off and then back on again [out to the load state] resulting in a drive error. The software uses this bit to determine if a pack change was made. The get status command with the reset bit asserted (03) will clear the condition.		

Write protected during SERVO pulse time.

- 10 = Write gate error — Write gate was asserted during one or more of the following times:
 - Drive is *not* "ready to read/write"
 - Drive is write protected
 - Drive is in the midst of sector pulse time
 - Drive has another error asserted.
- 11 = Spin error (pack failed to get "up to speed" within 39 sec. or disk is overspeeding).
- 12 = Seek time-out error (the timer on "ready to read/write" timed out indicating the seek took too long, or "ready to read/write" is lost while in "lock-on" or position mode.
- 13 = Drive is write locked.
- 14 = Head current error. (write current was sensed without write gate being asserted)
- 15 = Write data error (a write data pulse did not arrive within the time frame established after receipt of write gate)

B. Read Header Command Results

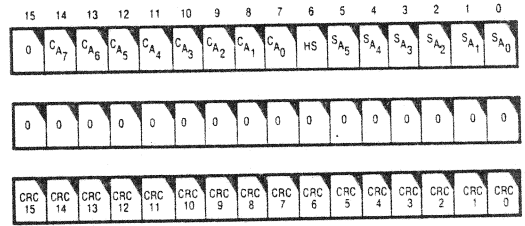

These 3 consecutive words read from the disk surface during a read header command, are stored in the controller's silo and are accessible by executing consecutive move instructions from address 774406.

C. Word Count Results

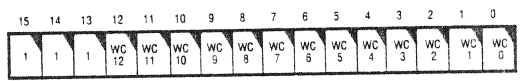

3 words of header info. { 1st TK / SECTOR, 2nd 0's, 3rd CRC's

- 0 }
 ↓ } Two's complement of the total number of words
 12 } desired to be transferred.
 13 }
 ↓ } Must be ones to have the word count in the
 15 } correct range.

NOTE: This disk does *not* do spiral read/write operations. One track's worth of data ($5,120_{10}$ words) is maximum amount allowable with one programming session. Word count would equal $166,000_{10}$. (2 's complement of $12,000_{10}$)

PROGRAMMING INFORMATION

1. Since only 4 drives is allowable per controller, a second set of Unibus addresses is needed for a possible second controller with up to 4 more drives.
2. The RL11/RL01 Disk Subsystem does *not* do any implied SEEKS. The SEEK must be programmed independently of the READ or WRITE operation.
3. SEEK Difference calculation is done by the software. The Read header command is used to first get the current location of the heads over the disk.
4. The subsystem does *not* spiral READ or WRITE. Only one track at a time (max.) can be programmed. $40 \text{ sectors} \times 128 \text{ words} = 5120_{10} = 12000_8 = 166,000$ (2 's comp.).
5. The RL11 does not have a "GO" bit in the usual sense. Bit 0 of the C.S.R. is now the Drive Ready bit. A "GO" command is now accomplished by writing a zero into the asserted bit 7 position of the C.S.R. (controller ready).
6. The volume check bit of the drive status (bit 09) is for software use only. If the top cover is opened,

or if the run/load switch is pushed to "load," a drive error will occur when the drive is put back to the RUN state. An interrupt will then occur to the software. *COMMANDS CAN STILL BE GIVEN THE DRIVE.* This kind of drive error does not light the fault lamp.

SAMPLE PROGRAMMING STEPS

In order to have the drive READ or WRITE at a specific address, the following programming steps may have to be utilized.

1. Status condition of the drive may be sampled by loading the D.A.R. and then the C.S.R. with the GET Status command.
2. Upon receipt of CONTROLLER READY, the M.P.R. can then be examined for the error and status condition of the desired drive.
3. The current position of the heads can then be found by issuing a READ Header command to the C.S.R. The drive will then READ the first header it sees and send it to the M.P.R.
4. Upon receipt of CONTROLLER READY, one, two, or three successive MOVE commands from the M.P.R. can be issued to allow the software to "READ" the current header.
5. The software can now calculate the track difference between the current address as determined by the READ Header command and the desired track.
6. Issue this newly calculated track difference along with the desired head and sector addresses to the D.A.R.
7. Issue a SEEK command to the C.S.R.
8. Upon receipt of DRIVE READY, the software can now load the word count in the M.P.R.

Load D.A.R. with 3_2 or 13_2
then load CSR with get
status command. i.e. Set
bits 8 & 9 for drive.

Load DAR with Tr. diff -
then issue Seek
command to CSR

9. Load the B.A.R. with the core address desired.
10. Load the D.A.R. with the desired track address, sector address, and head number so that the hardware can do a header compare.
11. Load the C.S.R. with the data transfer command keeping bit 7 a 0 to act as a "GO" bit.

The controller then will initiate a header compare operation unless the function code is 7. (READ data without header compare).

1. Successive headers will be read until a successful compare is made or the 200 msec. operation timer issues an error.
2. When header is found, start the data transfer command.

**PROGRAM TO PERFORM OSCILLATING SEEKS
OR TO SELECT HEAD 0 OR 1 FOR ALIGNMENT
CHECKS**

*Diagnostic alignment
Senses WR PROT
& switches heads
in this way.*

LOCATION	CONTENTS	COMMENT
000160	000600	VECTOR ADDRESS
000600	000002	RTI
001000	012706	500 → R6
001002	000500	
001004	005037	CLR PSW
001006	177776	
001010	013737**	SWR = TRK
001012	177570**	Displacement
001014	174404	
001016	012737	SEEK;
001020	*	SELECT DRIVE
001022	174400	
001024	000001	WAIT
001026	042737	CHANGE DIRECTION
001030	000004	
001032	174404	
001034	012737	SEEK;
001036	*	SELECT DRIVE
001040	174400	
001042	000001	WAIT
001044	000755	BR
001046	000000	

NOTES: Load 1 into SWR for head 0 } Used for alignment
Load 21 into SWR for head 1 } and amplitude checks
Load 077605 into SWR for 255 cyl seek
Load 205 into SWR for 1 cyl seek
Load 25205 into SWR for 85 cyl seek

*Drive 0 000106
Drive 1 000506
Drive 2 001106
Drive 3 001506

**For CPUs without SWR
001010 012737
001012 Place value that would
normally be in SWR.

**PROGRAM TO WRITE DATA FROM LOCATIONS
1000 TO 1200 AND READ BACK TO
LOCATIONS 2000 TO 2200**

ADDRESS	CODE	MNEMONIC
17776	000005	Reset
20000	032737	Bit
20002	000201	Controller & Drive Ready?
20004	774400	C.S. Register
20006	001774	BEQ-4 Wait
20010	012737	MOV
20012	001000	1st Memory Address of NPR
20014	774402	B.A. Register
20016	012737	MOV
20020	177600	Word Count
20022	774406	W.C. (M.P.) Register
20024	012737	MOV
20026	000000	
20030	774404	D.A. Register
20032	012737	MOV
20034	000012	Write data Command
20036	774400	C.S. Reg.
20040	032737	Bit
20042	000201	Controller & Drive Ready?
20044	774400	C.S. Register
20046	001774	BEQ-4 Wait
20050	012737	MOV
20052	002000	1st Memory address of NPR
20054	774402	B.A. Reg.
20056	012737	MOV
20060	177600	Word Count
20062	774406	W.C. (M.P.) Register
20064	012737	MOV
20066	000000	
20070	774404	D.A. Reg.
20072	012737	MOV
20074	000014	Read Data Command
20076	774400	C.S. Reg.
20100	032737	Bit
20102	000201	Controller & Drive Ready?
20104	774400	C.S. Reg.
20106	001774	BEQ-4 Wait
20110	000000	HALT

NOTES: Toggle data pattern desired into locations
1000 to 1200 before starting.

RL01 SERVO DATA FORMAT

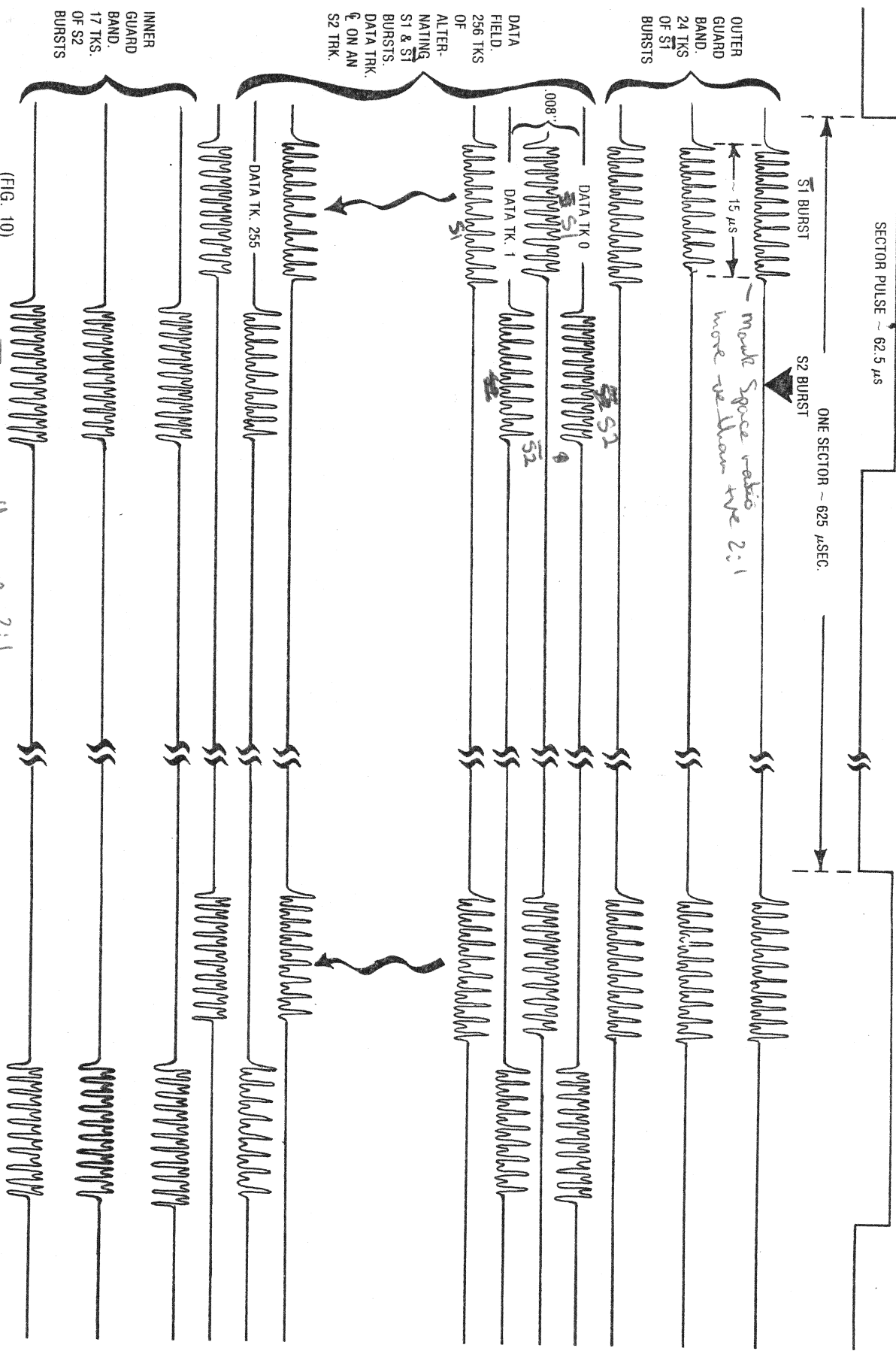

(FIG. 10)

S2 more or less the 2:1

SERVO DATA SIGNAL GENERATION

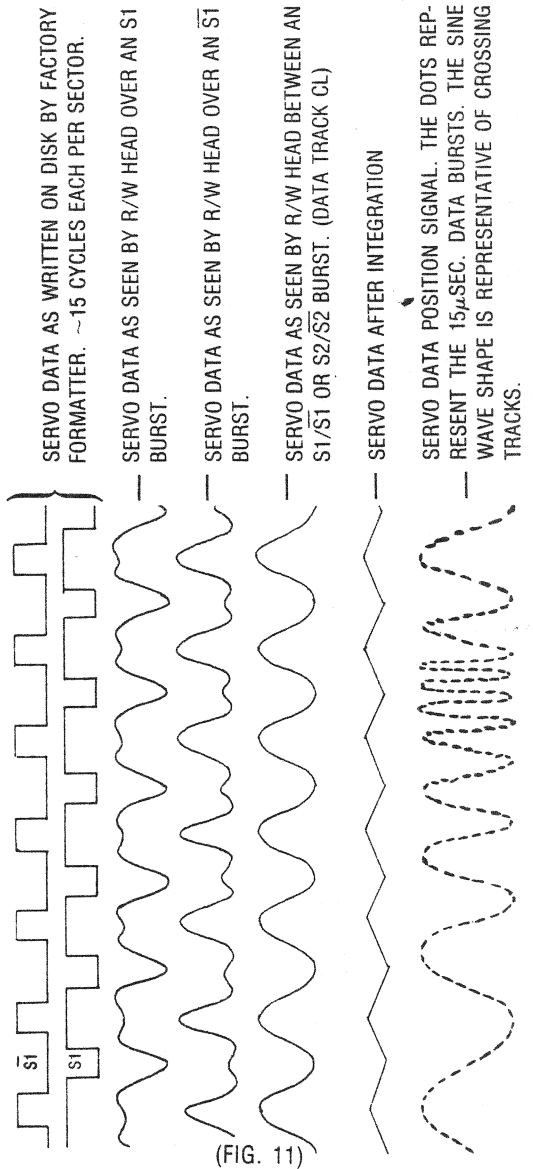

(FIG. 11)

M7762 RLLI BASIC BLOCK DIAGRAM

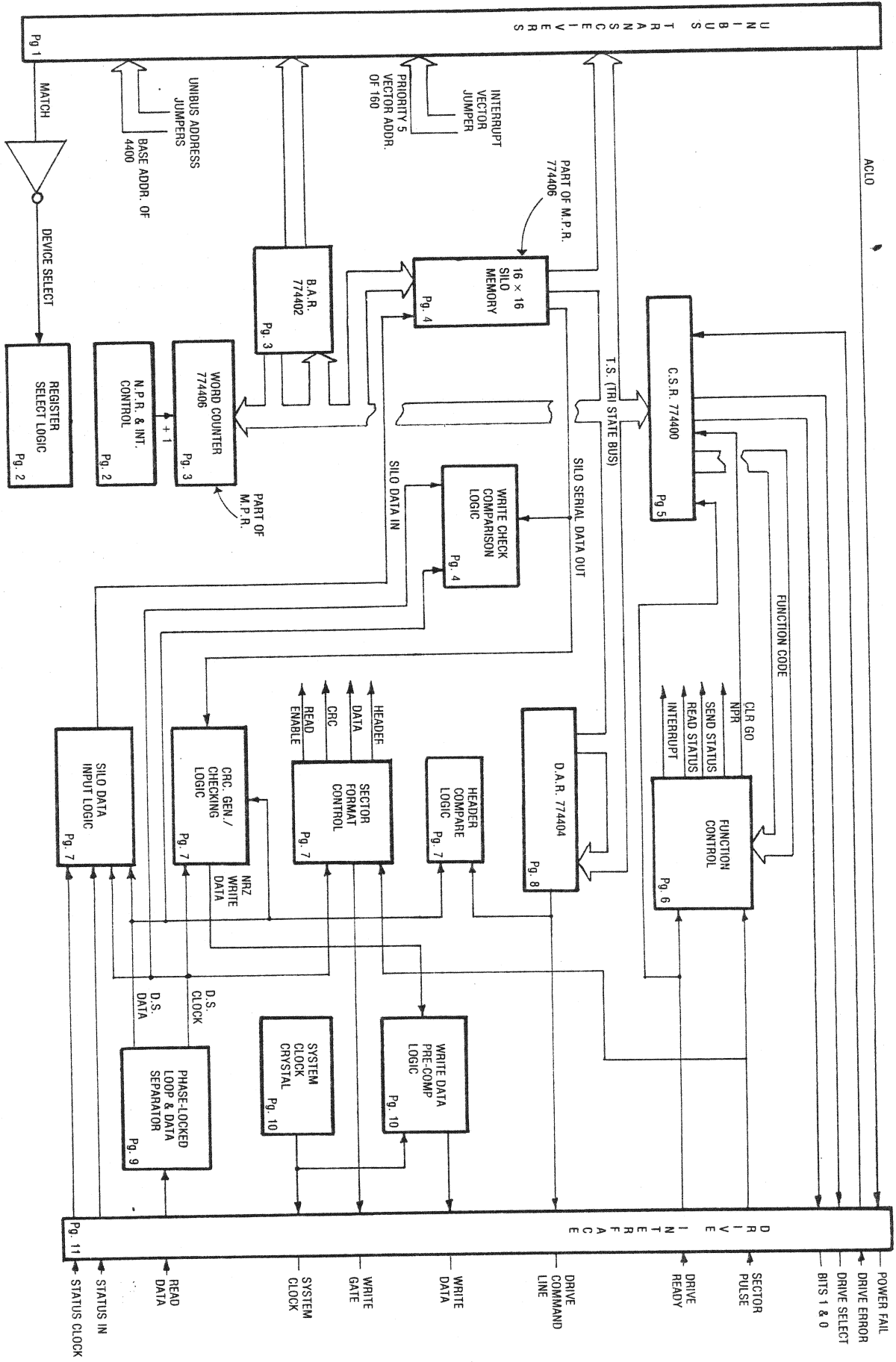

(FIG. 12)

RLV11/RL11 BOOTSTRAP LOADER

LOCATION	CONTENTS	COMMENTS
10000	012737	Load Read
10002	14	Data to CSR
10004	174400	
10006	000001	Wait

Start program at 10000 and run for a minute. Then load address 000000 and start boot.

NOTE: To boot other than drive 0, location 10002 should contain the drive number in the upper byte.

RL8A BOOTSTRAP LOADER

LOCATION	CONTENTS	COMMENT
7000	6600	RLDC
7001	1204	TAD READ CMD
7002	6604	RLCB
7003	5203	JUMP SELF
7004	*	READ FUNCTION

*0006 for Truncated Mode
1006 for Byte Mode

Allow program to run 1 second.
Load address 0000 and start.

Field Replaceable Unit (FRU) List and DEC Part Numbers

1. MODULES
 - A. R/W — 54-11844
 - B. Front Panel — 54-11846
 - C. AC Servo — 54-11848
 - D. DC Servo — 54-11850
 - E. Drive Logic Module — 54-12175

II. CABLES

- A. I/O cable — 70-12122
- B. BCO6R-10
- C. Front panel to drive logic module — 70-12107
- D. I/O to drive logic module — 70-14262
- E. DC Servo to drive logic module — 70-12139-F
- F. R/W to drive logic module — 70-12139-F
- G. AC Servo to drive logic module — 70-14262
- H. Power harness to drive logic module — 70-12140
- I. Brush drive harness — 70-12126
- J. Power panel harness — 70-12108
- K. Line cord — 70-12109
- L. Muffin fan cable — 70-12110
- M. I/O cable terminator — 70-12293-00

III. R/W HEADS

- A. "A" up — 7417178
- B. "A" down — 7417178-01

IV. FILTERS

- A. foam (coarse) — 7415297
- B. absolute — 12-13097-03

V. BRUSH ASSEMBLY

- A. drive assembly — 70-12112
- B. upper brush holder — 75-15226-01A
- C. lower brush holder — 75-15225-01A

VI. MECHANICAL ASSEMBLIES

- A. drive belt — 12-13369
- B. drive motor assembly — 70-12114
- C. spindle assembly — 70-12120
- D. ground brush — 74-15294
- E. sector transducer — 70-12137
- F. positioner assembly — 70-12117
- G. power panel assembly — 70-12130
- H. muffin fan — 12-09403-1
- I. voltage conversion terminal block 74-16852-01A

VII. COVERS

- A. cartridge access — 70-12115
- B. module access — 70-12119
- C. cover locking solenoid access — 70-12128
- D. spindle grounding brush access — 74-17450

PREVENTATIVE MAINTENANCE SCHEDULE

Annual (or 3000 hours)

1. Inspect and clean heads
2. Inspect and clean spindle area
3. Replace pre-filter
4. Replace absolute filter
5. Replace spindle grounding cone
6. Inspect drive belt
7. Inspect disk brushes for wear
8. Check power supply voltages
9. Check head amplitude
10. Check head alignment
11. Check carriage alignment
12. Run the following diagnostic:
DZRLE Performance exer.

SERVICING TIPS

I. MANUALLY MOVE CARRIAGE

Take apart the in-line connector (shown in the illustration, Figure 14) after the heads are loaded and flying. Do *not* manually load the heads over

the pack. Let the logic initially move the carriage at the *proper* speed over the loading ramp.

II. TOP COVER

Servicing should be done with the cartridge access cover in place. Should you find it necessary to remove it and service the drive with a pack in place, the following should apply:

1. Place a weight of approximately 2 to 5 pounds on top of the cartridge dust cover. This is to *ensure* the rotating air mass coupled with the inherent vibration from the spindle does not cause the pack to unseat itself from the spindle hub.
2. To enable the heads to load it will be necessary to place an I.C. clip on E33 of the drive logic module and jumper pin 3 to pin 7 of the I.C. clip. This will defeat the top cover interlock.

III. OPENING TOP COVER WITH POWER OFF

1. Remove two Phillip's head screws securing an access cover on right side of drive. See Figure 15.
2. Pull down on solenoid plunger to release the hold on the cover.

CAUTION: Ensure this cover is replaced before powering up drive. Contamination of the clean air system could occur if not adhered to.

IV. R/W HEAD PLUGS

These plugs are not labeled on this machine. Looking at the R/W module, the designated J3 is the connector for the lower head (head #1) while J2 is the connector for the upper head.

V. TO MANUALLY SELECT HEAD 1

Swap J2 & J3 connectors on the R/W module. This will enable you to observe the signals being read by head 1.

VI. HEAD ALIGNMENT

To avoid the hassle of repeatedly swapping the

J2 & J3 connectors to observe the head alignment signals, a routine has been designed into diagnostic "C" (drive test part 1) to utilize the WRITE PROTECT switch to select the desired R/W head.

To enable the routine to work, two jumpers must be added to the drive logic module to force a "drive ready" condition:

1. E17 pin 6 (seek time-out error) to ground
2. TP8 (position signal) to ground

R/W MODULE AND SERVO IN-LINE CONNECTOR

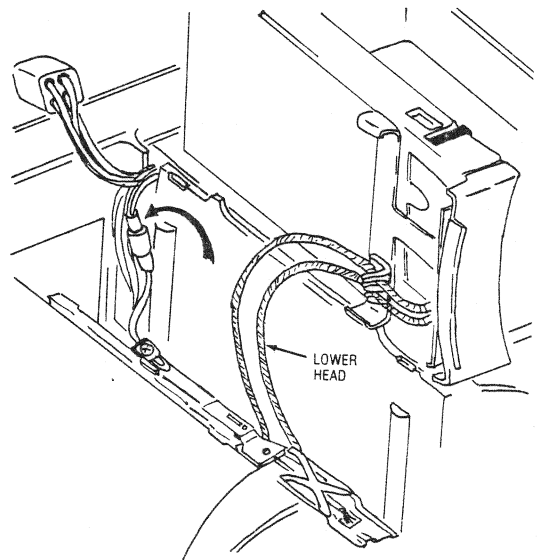

(FIG. 14)

TOP COVER LOCKING SOLENOID ACCESS

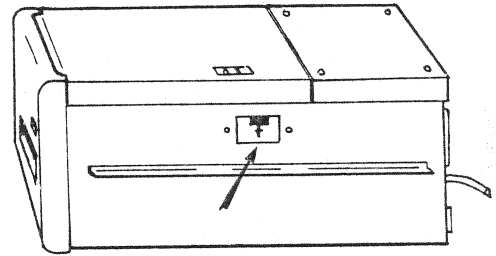

(FIG. 15)

OBSERVATION OF DRIVE ERRORS USING AN O'SCOPE ON THE D.L.M.

1. Drive select error	(L)	E21-1
2. Write Data error	(H)	E15-4
3. Clock error	(H)	E15-3
4. Current in heads	(H)	E15-5
5. Spin Error	(H)	E10-5
a Spin-up error	(L)	E20-4
b 593 μ s LT and sec det	(L)	E20-2 E20-3
6. Seek time-out error	(H)	E10-4
7. Write Gate error	(L)	E12-11
Write Gate	(L)	E65-9 and
one of the following:		
a. Ready to read/write	(H)	E15-1
b. Write lock	(H)	E24-5
c. Drive error	(H)	E24-4
d. 625 μ s lt/sec time	(H)	E15-13
8. Volume Check	(H)	E24-1

NOTES:

- Errors 1, 2, 4, 5, 6, 7 & 8 appear in M.P. register as a result of get status command.
- Errors 2, 3, 4, 5a generate an error state command which causes the heads to unload.

RL01 DRIVE

CHECKS & ADJUSTMENTS

I. GROUNDING CHECKS

- A. Spindle cone to ground screw on sector transducer should be $< 50\Omega$
- B. Green wire representing drive motor ground to ground should be $< .2\Omega$

II. VOLTAGE CHECKS

Using a D.V.M. on the test points of the D.C. servo module:

- A. TP8 for +4.9 to 5.2V
- B. +8VTP for +7.7 to 8.3V
- C. -8VTP for -7.7 to 8.3V
- D. -V UNREG TP for -14 to -18V
- E. +VUNREG TP for +14 to +18V

If any voltages do not meet spec., the transformer bridge rectifier, and filtering Cap's are located directly under the D.C. servo module. There are *No* voltage adjustments.

III. RAW SECTOR TRANSDUCER OUTPUT CHECK

- A. With pack installed and heads loaded, observe E8 on pin 8 of the drive logic module for the following:

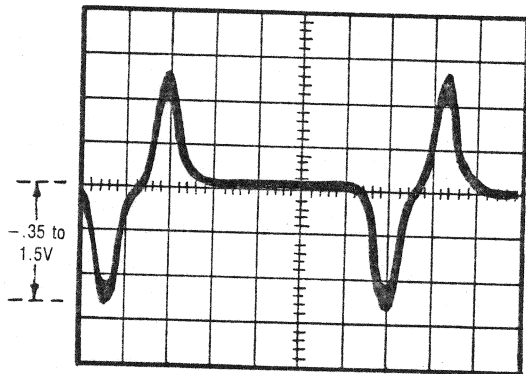

(FIG. 16)

NOTE: The waveform *must* be negative-going first. If it is positive — going first, it is an indication that the sector transducer is wired backwards. This will also result in a jittery second pulse (Fig. 16) this jitter will cause the servo to track erratically.

IV. SECTOR PULSE TIMING CHECK

Observe E-7 pin 9 on the drive logic module for the following:

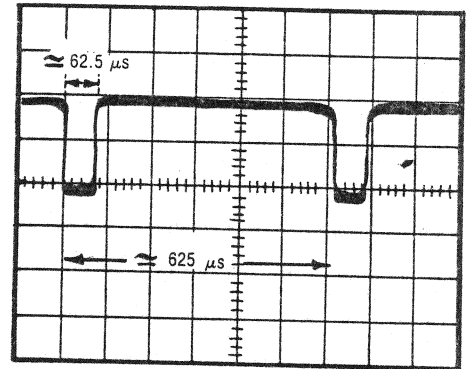

V/CM: 2V
TIME: 100μSEC

(FIG. 17)

Correct disk speed ranges from 594 μ sec. to 639 μ seconds with 624 being the desired norm. The sector pulses should be stable at some time period within that range.

If not within spec. check the A-C Servo module for fault.

V. READ SIGNAL AMPLITUDE CHECK

A. Required tools:

1. Oscilloscope with three probes
2. DIP Clips and jumpers
3. Diagnostic DZRLC for the head alignment routine.

Note: This check will have you comparing the amplitudes of both R/W heads to the Engineering Specification. The

head that shows out of tolerance is to be replaced and the procedure repeated until both heads show within tolerance. This is then followed up with a head alignment.

B. Check

1. Remove both top cover assemblies (reference Figure 4, step 1).
 2. Place R/W module up and out of the way of the carriage assembly.
 3. Defeat top cover interlock (see SERVICING TIPS, 11).
 4. Install cartridge.
 5. Depress "load" switch.
 6. After heads load onto pack disable servo drive to carriage by disconnecting the positioner harness inline connector (see Figure 14).
 7. Set up Oscilloscope as follows:
 - a. Channel 1 probe should be on TP1/2 of the R/W module (servo data).
 - b. Channel 2 probe should be on E11 pin 7 of Drive Logic Module (position signal).
 - c. External sync probe should be on TP9 of Drive Logic Module (sector time).
 8. Observe a waveform similar to that on Figure 18.
 9. Install (2) jumpers on Drive Logic Module:
 - a. E17 pin 6 (Seek time out error) to E17 pin 7 (ground).
 - b. TP8 (DL7-position signal) to ground (TP1 thru 6 are ground points).
- Note: These jumpers enable the diagnostic routine to work by disabling the Seek time-out error.
10. Load DZRLC and call up head alignment routine.
 11. Move the positioner forward until the

S1 servo burst loses amplitude and finally disappears. This will be the inner guard band area of the disk.

12. Pull the positioner back slowly until the S1 servo burst returns. This will be the last data cylinder on the disk.
13. Carefully move the positioner until it is on the track centerline. This is done by observing the Channel 2 signal which is the integrated position signal. It will be at a ground reference when on track (see Figure 18).

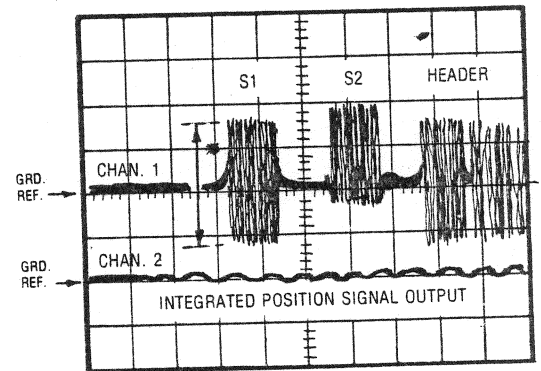

(FIG. 18)

14. Measure and record the amplitude of the S1 burst for both heads while on this track centerline. (shown as the * in Fig. 18). Ensure that the positioner does not move from the track centerline.
15. The lower of the two amplitudes should be no less than 432 mV.
16. Reposition carriage to track 0 using the same procedure as defined for 255. This time the S2 burst will disappear.

17. Measure and record the amplitude of both heads.
18. Maximum amplitude of S1 burst on track 0 should be no greater than 2.38 V.
19. Replace head(s) that do not meet specification, then proceed with the next two alignments.

VI. Positioner Radial Alignment

A. Tools Required:

1. O'Scope with two probes
2. Two flat blade screwdrivers
3. One phillip's head driver
4. One DIP clip, one pin-to-pin jumper and one test lead or,
- 4a. Two pin-to-pin jumpers and two DIP clips.
5. Diagnostic DZRLC for the head alignment routine.

This adjustment ensures that the pre-recorded servo data as read by the R/W heads are properly positioned in relation to the sector pulses from the cartridge hub. It also enables the technician to observe how "straight" the carriage motion is over the length of travel as well as check for R/W head skew.

B. Positioner Alignment Check

1. Install (2) Jumpers on the Drive Logic Module:
 - a. E17 pin 6 (seek time-out error) to E17 pin 7 (ground)
 - b. TP8 (position signal) to ground (TP1 thru TP6 are ground TP's)
2. Install cartridge
3. Depress "load" switch
4. Wait for heads to load onto pack.
5. Disable servo drive to the carriage by disconnecting the positioner harness in-line connector. (See Fig. 14)
6. Select the lower head (#1) by loading

DZRLC diagnostic and calling up the head alignment routine. This enables head #1's read signal to be used as the reference for this adjustment. When installed, this head rests up against a dowel locating pin serving as the only adjustment for head #1.

7. Set up O'Scope as follows:
 - a. Chan "A" probe should be on TP9 of drive logic module (Fig. 20)
 - b. Chan "A" ground should be on any signal ground (TP1-6) of drive logic module.
 - c. Chan "B" probe should be on TP1 of R/W module.
 - d. Chan "B" ground should be on the test point ground of R/W module.
8. Observe the following waveform:

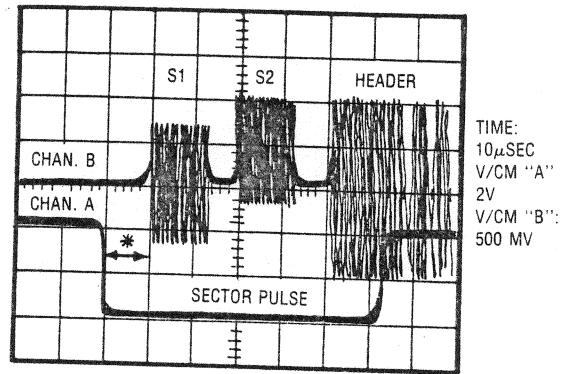

(FIG. 19)

9. Observe that the place on Fig. 19 noted with an * is $15 \pm 5\mu\text{sec}$ when the positioner is at cyl. 0.
10. If specification cannot be met, continue on to the adjustment procedure. If adjustment is within spec. go to step 11.

16.5µs

DRIVE LOGIC MODULE TEST POINTS

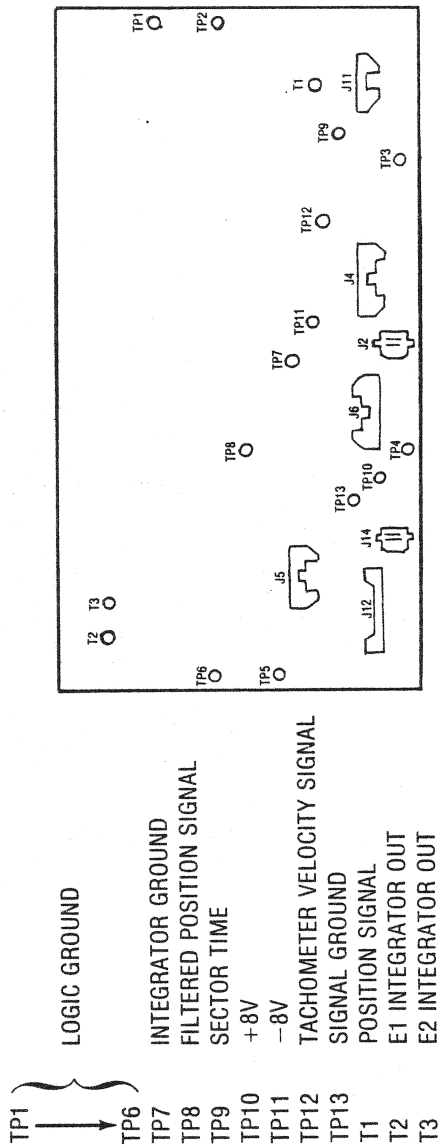

(FIG. 20)

NOTE: T1-T3 are formatter wiring pads.

11. Manually move carriage to track 255 (last data track).
12. Observe that the place on Fig. 19 noted with an * is $15 \pm 5\mu\text{sec}$.
13. If specification cannot be met, continue on to the adjustment procedure. If adjustment is within spec. go to VIII. (Spindle runout check.)

C. Positioner Adjustment

1. Using Fig. 21 as a guide, locate the six largest phillip's screws on the positioner baseplate. (They are noted in the illustration by Ø)
2. Loosen (do not remove) the six screws holding down the positioner.
3. Take the two flat-blade screwdrivers and insert them into the adjusting slots shown in the illustration.
4. Move the positioner assembly against the right-hand side of the drive (toward the R/W module in the illustration.)

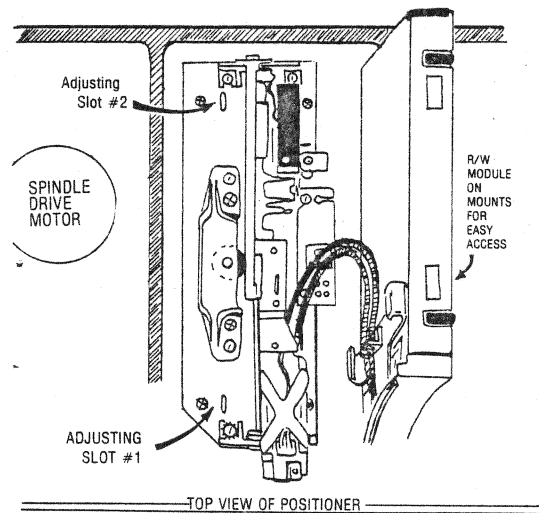

(FIG. 21)

5. Manually move carriage to its center of travel.
6. Using the two flat-blade screwdrivers in the adjusting slots, slide the positioner baseplate until the 15 ± 5 μ sec spec. between the fall of the sector pulse and the rise of the S1 servo burst can be met. (Fig. 19)

NOTE: Equal pressure must be exerted on the screwdrivers when sliding the positioner to ensure that the baseplate is kept straight.

7. Tighten the six retaining screws in small increments.
8. Check the engineering spec. at track 0 and at 255. (Steps 9 thru 13 of positioner alignment *check*.)
9. Select the upper head.
10. Check to see if the upper head also meets the engineering spec. just obtained, and if not adjust the positioner such that both heads meet spec.

NOTE: If both heads cannot be made to meet specification on this check, then head skew is present. Head 0 should be replaced first to see if it was the cause of the skew, and if not, then head one. If this was done, then the R/W heads must be checked for a balance of their respective read signal amplitudes. (V of this section) following that a head alignment must be performed (VII of this section) and finally the radial alignment.

VII. HEAD ALIGNMENT

A. Required Tools:

1. Oscilloscope with 3 probes
2. head screw torque wrench
3. 3/32" allen wrench
4. flat blade screwdriver
5. DIP clips and jumpers

6. diagnostic DZRLC
- Note: No alignment cartridge is needed for this procedure because the servo data and customer data is being read by the same R/W heads. All that needs to be done is to ensure that the two heads are in line with each other. This will cut down the servo tracking time when switching heads. The lower head (#1) was aligned when installed by seating it against its locating pin on the carriage frame.

B. Alignment Check

1. Remove both top cover assemblies (reference Figure 4, step 1).
2. Place R/W module up and out of the way of the carriage assembly (see Figure 7).
3. Defeat the top cover interlock (see SERVICING TIPS #11).
4. Install cartridge
5. Depress LOAD switch
6. After heads load onto pack disable drive to carriage by disconnecting the positioner harness in-line connector (see Figure 14).
7. Set up Oscilloscope as follows:
 - a. Channel A probe should be on TP1 of the R/W module (servo data).
 - b. Channel B probe should be on E11 pin 7 of the Drive Logic Module (position signal).
 - c. External sync probe should be on TP9 of Drive Logic Module (sector time).
8. Observe a waveform similar to that on Figure 18.
9. Install (2) jumpers on Drive Logic Module:
 - a. E17 pin 6 (Seek time out error DL5) to E17 pin 7 (ground).

b. TP8 (DL7 position signal) to ground (TP1 thru TP6 are grounds)

Note: These jumpers enable the diagnostic routine to work by disabling seek time out error.

10. Load DZRLC and call up head alignment routine.

11. Select the lower head (#1) by depressing the write protect switch on front of the drive. For more information see the diagnostic section of this handbook.

Note: Using the diagnostic routine is the preferred method for head alignment. If it *must* be done off-line, then the only method of selecting R/W heads is to swap head plugs. This is *not* the recommended procedure because the head plugs and/or pins on the R/W module may be damaged.

12. Manually move the carriage slowly in reverse until the S2 servo burst amplitude decreases. (Reference Figure 22). Stop when the S2 signal reaches ground potential.

Note: When S2 signal has completely disappeared head 1 is in the outer guard band. E.G., $S1 = S2$ peak to peak amplitude signifies head on track (reference Figure 18.)

$S1 > S2$ peak to peak amplitude signifies head approaching outer guard band (reference Figure 22).

$S1 < S2$ peak to peak amplitude signifies head approaching inner guard band.

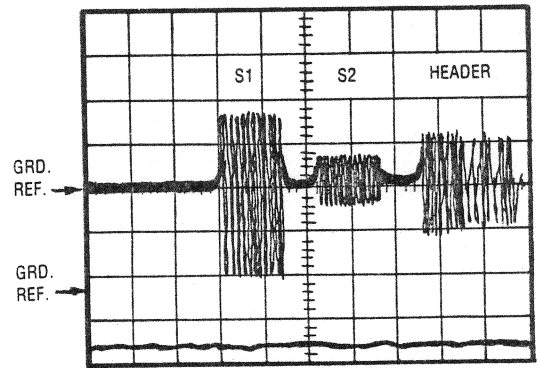

TIME: 10 μ SEC.
V/CM: 500 MV

(FIG. 22)

13. Without disturbing carriage, carefully remove hand.

14. Select head 0 by resetting the WRITE protect switch if using the on-line diagnostic or swapping the head plugs back to their original position.

15. Observe that the S2 servo burst on head 0 (upper) is less than the amplitude of S1. This ensures that head 0 is also on outer guard band side of track 0.

Note: If S2 is equal to or more than S1, head 0 is one track or more displaced towards the spindle. This head must be aligned: Go to step 1 of alignment. If S2 is less than S1: Go to step 16.

16. Select head 1.

17. While observing the integrated position signal output (reference Figure 18) slowly move the positioner forward until the position signal is exactly on ground. (This represents the data track centerline for cylinder 0).

Note: The carriage is now at the head alignment reference.

18. Without disturbing the carriage, carefully remove hand.
19. Select head 0 and note whether the position signal is more than .5 volt displaced from the ground reference.

Note: If less than .5 volt is observed, no alignment is necessary. If positioner radial alignment is not to be performed, restore drive to normal. If more than .5 volt is observed, head 0 must be aligned. Proceed to next step.

C. Alignment of Heads

1. Using the 3/32" allen wrench, loosen head 0 retaining screw and slide the head to the rear against its stop.
2. Re-establish the carriage reference by repeating steps 16 thru 18.
3. Select Head 0.
Caution: In performing steps 4 & 5 ensure that the carriage does not move.

Note: While performing the next adjustment observe that the position signal moves toward ground.

4. Insert flat bladed screw driver between the tailstack of head 0 and rear stop.
5. While holding carriage, slide head 0 forward until position signal reaches ground.
6. Tighten head retaining screw to recommended torque.
7. Verify alignment by repeating steps 16 thru 19.

VIII. SPINDLE RUNOUT CHECK

Excessive runout in the spindle assembly or cartridge can cause severe tracking problems for the positioning system. This check will confirm:

- 1 Runout exists or does not exist
- 2 Runout is in the cartridge

3 Runout is in the spindle

A. Tools Required:

1. O'Scope with probe & ground
2. Several test cartridges

B. Runout Check

1. Insert cartridge into drive
2. Depress "Load" switch
3. Wait for heads to load onto pack
4. Disable servo drive to carriage by disconnecting the positioner harness in-line connector. (See Fig. 14)
5. Set up O'Scope:
 - a. Chan 1 probe should be on E11 pin 7 of drive logic module
 - b. Chan 1 ground should be on TP7 of drive logic module. (Integrator ground)
6. Observe the following waveform:

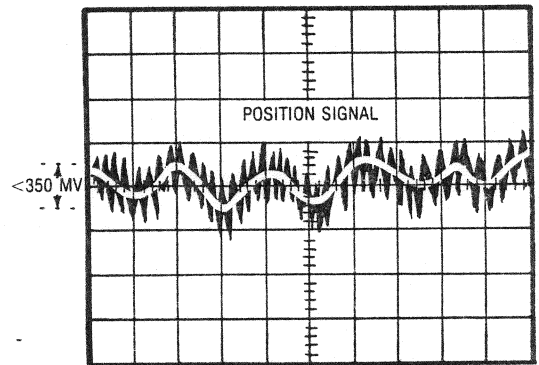

TIME: 5MSEC/CM
V/CM: 200 MV

(FIG. 23)

7. The waveform representing runout should be measured symmetrically about the ground reference.
8. The amplitude of the runout should be no greater than 350 mv.

NOTE: If an ideal waveform could be pre-

- sented, the display could be a near-straight line of dots.
9. If specification cannot be met, runout exists and another cartridge may be needed to determine if the runout exists in the cartridge or the spindle.
 10. To confirm a seating problem, re-seat the cartridge and repeat runout check, if now within spec. the problem is found, if still out, go on to step 11.
 11. Spindle & cartridge are still suspect, so install a second cartridge and repeat check. If runout is within spec. 1st cartridge is bad. If the runout check fails once more assume spindle bearings are bad and replace spindle assembly.

IX. POSITION SIGNAL GAIN CHECK

Insufficient amplitude in the position signal could result in the carriage not being able to hold itself on track resulting in read errors and possible seek errors. Too high an amplitude could result in a jitter which in turn emits a vibrating type noise from the carriage and seek time-out errors.

A. Tools Required:

1. O'Scope with probe & ground

B. Gain Check

1. Install cartridge
2. Depress "Load" switch
3. Wait for heads to load onto pack
4. Disable servo drive to carriage by disconnecting the positioner harness in-line connector. (See Fig. 14)
5. Set up O'Scope:
 - a. Chan "A" probe should be on E11 pin 7 of drive logic module.
 - b. Chan "A" ground should be on TP7 of drive logic module. (Integrator ground).
6. Observe the following waveform while moving the carriage back and forth:

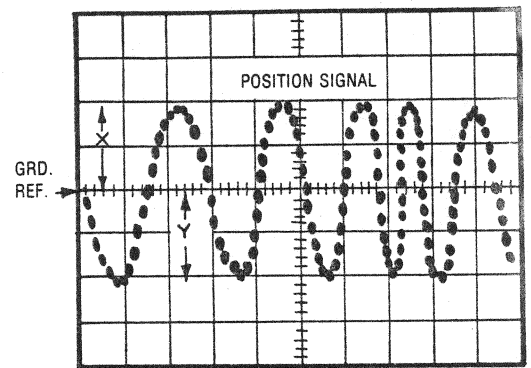

TIME: 5MS/CM
V/CM: 1 VOLT

(FIG. 24)

7. Measure the peak deviation of the position signal amplitude about the ground reference in both directions (x and y). These amplitudes should not exceed the limits of 1.5 to 2.2 V each.

NOTES:

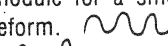
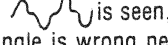
1. If this is out of tolerance, the head load operation would most likely fault
2. Check the servo data waveforms at TP1 of R/W module for a smooth sinusoidal waveform.  If something like  is seen, the head azimuth angle is wrong necessitating the replacement of the R/W head.
3. If head azimuth indicates OK then check the ± 8 VDC voltages for being out of tolerance.

X. TACHOMETER A.C. NOISE PICK-UP CHECK

- A. Load heads to track 0, then disconnect the in-line servo plug disabling positioner drive. (Fig. 14)
- B. Each drive's summing amplifier output at this point will look slightly different, but observe a waveform similar to the following:

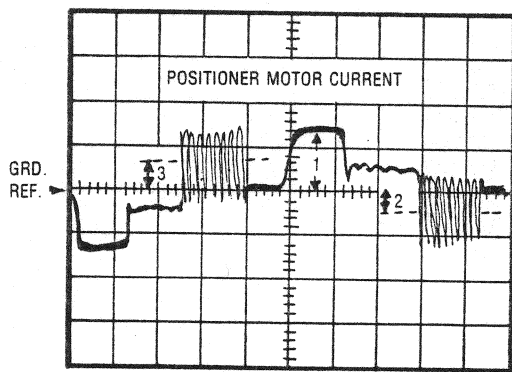

TIME: 20 MS/CM
V/CM: 500 MV

(FIG. 27)

Chan. "A" probe should be on TP3 of D.C. servo module.

External Trigger: E38 Pin 12 of Drive Logic Module (Sign FWD.)

XIII. ACCESS TIME CHECK

- A. Load Heads
- B. Using diagnostics or a hand-written program issue a one-track seek.
- C. Observe the following waveform:

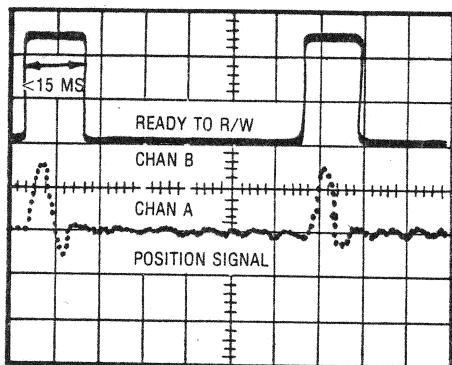

TIME: 10 MS/CM
V/CM "A": 1V
V/CM "B": 2V

(FIG. 28)

Chan "A" probe should be on E11-Pin 7 of Drive Logic Module.
Chan "A" ground should be on TP7 of Drive Logic Module.
Chan "B" probe should be on E25 Pin 5 of Drive Logic Module.
Chan "B" ground should be on TP13 of Drive Logic Module.

- D. Measure the time it takes for the "Ready to read/write" low signal to go low after the seek has been issued.
- E. It should be ≤ 15 MSEC.
- F. Initiate a 0-85 TRK seek observing the same signals noting that "Ready to read/write becomes asserted within 55 milli-sec.

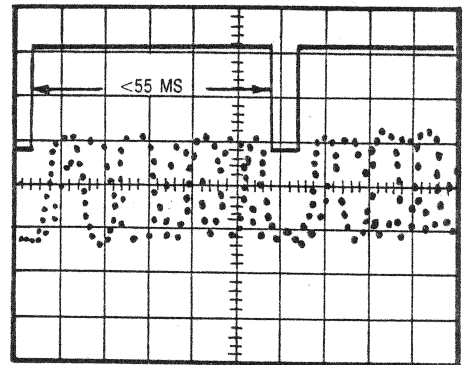

(FIG. 29)

- G. Issue a 0-255 TRK seek and now note that "Ready to read/write" becomes asserted within 100 MS.
- H. If specifications are not met, the drive logic module could be at fault, or the positioner itself is binding due to excessive friction. (See Step XII)

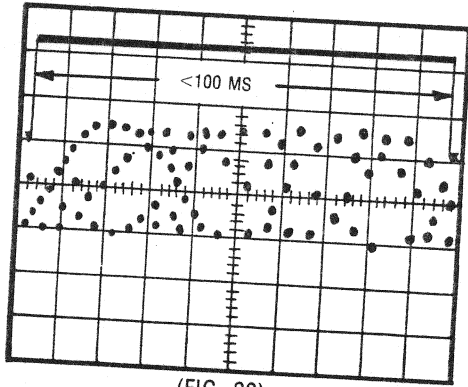

(FIG. 30)

RL01/RL11 DIAGNOSTIC SUMMARY

I. Diagnostics for the RL subsystem contain the following identification codes:

- DZRLA or, DVRLA for the controller Test #1
- DZRLB or, DVRLB for the controller Test #2
- DZRLC for the drive Test #1
- DZRLD for the drive Test #2
- DZRLE for the performance exerciser
- DZRLF for the drive compatibility test

II. Test Abstracts

A. RLA

1. Tests interface logic (with drive cabled)
2. Checks register set/clear accuracy
3. Exercises the following commands:
 - a. No-op
 - b. Get status
 - c. Read headers
 - d. seek

4. Requires 16 K minimum core Size to run, 24 K if running under an XXDP media
5. Standard loading procedures apply:
 - a. Starts @ 200
 - b. answer questions
 - c. receive a prompt at end of questions (DS A>)
 - d. enter a reply (STA <CR>)
 - e. answer more questions
 - f. Receive end of pass messages (or errors) in ~45 seconds.
 - g. to stop test enter a control 'C'

NOTE:

No progress reports issued with this diagnostic.

6. Test titles and numbers

1. RLCS addressability
2. RLBA addressability
3. RLDA addressability
4. RLMP addressability
5. R/W of RLCS
6. R/W of RLBA
7. R/W of RLDA
8. BIS of RLCS
9. BIC of RLCS
10. BIS of RLBA
11. BIC of RLBA
12. BIS of RLDA
13. BIC of RLDA
14. Bus reset of RLCS
15. Bus reset of RLBA
16. Bus reset of RLDA
17. Test uniqueness of RLCS
18. Test uniqueness of RLBA
19. Test uniqueness of RLDA
20. Test uniqueness of RLMP
21. No-op function
22. Test that no-op does nothing
23. Interrupt test
24. Test priority BR level
25. Get status function
26. Get status function interrupt

27. Get status function generates OPI
28. OPI causes interrupts
29. Read header function
30. Read header function interrupt
31. Repeated read headers yields same information
32. Check of header CRC
33. Check that header addresses are consecutive
34. Seek function
35. Check drive ready on seek
36. Seek function interrupt
37. Check difference word transmission
38. Verify head select 0 via read header command
39. Verify head select 1 via read header command
40. Verify head select 0 via Get Status
41. Verify head select 1 via Get Status
42. Test timing at which difference word gets transmitted
43. CRC check
44. Verify get status when DRDY is low

B. RLB

1. Tests controller (with drive cabled)
2. Checks the following commands:
 - a. write data
 - b. read data
 - c. write check
 - d. read data w/o header compare
3. Run "RLA" first
4. Requires 16K minimum core size to run, 24K if running under an XXDP media.
5. Standard loading procedures apply:
 - a. Starts @200
 - b. answer questions
 - c. receive a prompt at end of questions (DS A>)

- d. enter a reply (STA <CR>)
- e. answer more questions
- f. Receive end of pass messages (or errors) in ~ 90 seconds
- g. to stop test enter a control "C"

NOTE:

This program does not give any performance reports.

6. Test Titles and Numbers

1. Write NPR integrity
2. Write function
3. Write function interrupt
4. Proper increment of RLBA on write
5. Proper increment of RLDA on write
6. Force header not found with write
7. Force interrupt with HNF
8. Check OPI Time with HNF
9. Multiple sector transfer on write
10. Check direction of write NPR
11. Check full increment of RLBA
12. BA bit 16 increment
13. BA bit 17 increment
14. Read NPR integrity
15. Read function
16. Read function interrupt
17. Check direction of read NPR
18. Proper increment of RLBA on read
19. Proper increment of RLDA on read
20. Force header not found with read
21. Force interrupt with HNF
22. Check header compare logic
23. Multiple sector transfer on read
24. Force HNF at end of track
25. Force non-existent memory error
26. Force NXM under interrupt
27. Check read/write loop

28. Check of silo lines
29. Check throughput of silo with 128 unique data patterns.
30. Check zero fill on write
31. Check sector bits on header compare
32. Write check NPR integrity
33. Write check function
34. Write check function interrupt
35. Proper increment of RLBA on write check.
36. Proper increment of RLDA on write check
37. Multiple sector write check
38. Force DCK with write check
39. Check DCK with write check interrupt
40. Check zero fill on write with write check
41. Test write check command with different data patterns (Part 1)
42. Test write check command with different data patterns (Part 2)
43. Read without header compare
44. Read without header compare interrupt
45. Check read w/o HDR comp. reading capability
46. Check RLBA increment with read w/o HDR. comp. command
47. Check that RLDA does increment

C. RLC

1. Tests Disk Drive
 - a. basic drive logic
 - b. get status command with reset bit on
 - c. get status command
 - d. seek commands with no cylinder difference
 - e. read header command
 - f. has head alignment support

routine

- 1 on first pass only
- 2 when requested
2. run diagnostics "A" "B" first
3. requires 16K minimum core size to run, 24K if running under an XXDP media
4. standard loading procedures apply:
 - a. start @200
 - b. answer questions
 - c. receive a prompt at end of questions (DS A>)
 - d. enter a reply (STA <CR>)
 - e. answer more questions
 - f. receive end of pass messages (or errors) in ~ 3 minutes when doing manual intervention tests, or ~ 3 seconds otherwise.
 - g. to stop tests enter a control "C"
4. Test titles and numbers

TEST 1	Basic interface (Part 1)
TEST 2	Basic interface (Part 2)
TEST 3	Head Loading
TEST 4	Head unloading
TEST 5	Drive Select
TEST 6	Drive select test
TEST 7	Initial State
TEST 8	Initial Reset State
TEST 9	Drive Ready
TEST 10	Seek sign switch
TEST 11	Head alignment support
TEST 12	Head switching
TEST 13	Read Header (Part 1)
TEST 14	Read Header (Part 2)

Test 11 — Head Alignment Support Routine

This test is executed when the program is started at address 200, head alignment support is requested, and in the first pass only. It is bypassed in the second or subsequent passes.

Test 11 selects the drive under test and loops on a get status with reset. The write lock bit is monitored. When write lock is reset, head zero is selected. When write lock is set, head 1 is selected. This will permit the heads to be aligned in keeping with the present head alignment procedure without returning to the console.

Typing a carriage return on the console will terminate this test on the drive under test. Before terminating, the test will check that write lock is reset. If not, the operator will be requested to reset write lock.

Write Protect = Head one

Write Protect = Head zero

Carriage return terminates routine

D. RLD

1. Tests Drive
 - a. Interface and drive logic
 - b. seek tests
 - c. data transfers
2. Run tests "A," "B," & "C" first
3. Requires 16K minimum core size to run, 24K if running under an XXDP media
4. Standard loading procedures apply:
 - a. start at 200
 - b. answer the questions
 - c. receive a prompt at end of questions (DS A>)
 - d. enter a reply (STA <CR>)
 - e. answer more questions
 - f. receive end of pass messages (or errors) in ~ 8 minutes
 - g. to stop test enter a control "C"
5. Test titles and numbers

TEST 1 *Difference of 1 seek (Part 1)
 TEST 2 *Difference of 1 seek (Part 2)
 TEST 3 *Outer guard band detection
 TEST 4 *Incremental Forward seek head 0
 TEST 5 *Incremental Reverse seek head 0
 TEST 6 *Incremental Forward seek head 1
 TEST 7 *Inner Guard band detection

TEST 8 *Incremental Reverse seek head 1
 TEST 9 *Seek Tests
 TEST 10 *Forward oscillating seek
 TEST 11 *Reverse oscillating seek
 TEST 12 *Seek timing
 TEST 13 *Basic read data (bad sector file)
 TEST 14 *Write/read data (Part 1)
 TEST 15 *Spindle timing test
 TEST 16 *Write/read data (Part 2)
 TEST 17 *Write lock error and data protection
 TEST 18 *Adjacent cylinder interference
 TEST 19 *Overwrite

E. RLE

1. Randomly exercises up to 2 controllers with four drives each
 - a. writes data
 - b. programs random seek lengths
 - c. programs get status functions
 - d. reads headers
 - e. reads data
2. Run tests "A," "B," "C" and "D" first
3. Requires 16K minimum core size to run, 24K if running under an XXDP media
4. Standard loading procedures apply:
 - a. start @200
 - b. answer questions
 - c. receive a prompt at end of questions (DS A>)
 - d. enter a reply (STA <CR>)
 - e. answer more questions
 - f. receive end of pass messages (or errors)
 - g. to stop test enter a control "C"

NOTE:

Performance reports are given automatically or at operator request.

F. RLF

1. Checks compatibility between 2 to 4 drives using the same disk cartridge. The program will ask the operator to sequence the pack between the drives.
2. Run all other tests first to verify the logic.
3. Requires 16K minimum core to run
4. Standard loading procedures apply:
 - a. Start @200
 - b. Answer questions
 - c. Receive a prompt at end of questions (DS-A>)
 - d. Enter a reply (STA <CR>)
 - e. answer more questions
 - f. Receive end of pass messages or errors
 - g. to stop test enter a control "C"
 - h. To restart test repeat steps "a" thru "c" and substitute "RES" for "STA" in step "d." This will bypass step "e."

III. Notes on Diagnostic Supervisor

A. Hardcore Questions

1. The statement, "TYPE TWO CHARACTERS FOUR SECONDS APART," will be asked when no clock is on the system. The system will then subdivide the spacing for use as a clock.
2. The prompt "DS-A>" is requesting one of eleven superior "commands," which are:
 - STA - STArt diagnostic and then produce questions for generation of the diagnostic parameter tables ("P" tables).
 - RES - REStart diagnostic at the point following the hardware questions. The "P" tables set up by the STA command will be used.

- CON - CONTINUE the diagnostic at the beginning of the subroutine that was being executed when the diagnostic was halted by an error or control "C."
- PRO - PROceed testing with the diagnostic at the starting address of the subroutine following the one that caused the error report.
- DIS - DISplay the hardware "P" tables for all the drives under test.
- DRO - DROp the desired units from being tested. "UNITS," in this case, refers to the "P" table units, not necessarily the device unit numbers. The DIS command will give the operator the drive unit number.
- ADD - ADD units back into the testing sequence after they had been dropped by the DRO command.
- PRI - PRInt any performance or statistical tables accumulated by the diagnostic.
- FLA - FLAgs command - The current setting of all the flags set up under the STA command are printed out for inspection.
- ZFL - Zero FLAgs command - All current flags set by the STA command are cleared by this command.
- CCI - Create Core Image command - This command enables a BIC file to be created on these diagnostics to be run under the XXDP media. (See listing for directions.)

3. Program Parameter Changes - Type in any combination of the following parameters to affect the indicated commands.

With the STA command:

- a. DS-A > STA/TESTS: (Insert test numbers desired from the test lists in Paragraph II above; e.g., 1:2 means tests 1 and 2, or 1-5:8-10 means tests 1 through 5 and 8 through 10.)
- b. DS-A > STA/TESTS:6/PASS: (Insert the number of passes the diagnostic should take before halting.)
- c. DS-A > STA/TESTS:6/PASS:2/FLAGS: (Insert any of these mnemonic(s) representing a program flag(s)):
 - HOE - Halt On Error
 - LOE - Loop On Error
 - IER - Inhibit Error Report
 - IBE - Inhibit Basic Error reporting.
 - IXE - Inhibit eXtended Error reporting
 - PRI - PRInt messages on line printer
 - PNT - PriNT test numbers as they are being executed
 - BOE - Bell On Error
 - UAM - Bypass manual intervention tests
 - ISR - Inhibit Statistical Reports
 - IDR - Inhibit DRopping of Units
- d. DS-A > STA/TESTS : 6/PASS : 2/FLAGS : IER : PNT : BOE : IDR/EOP: (Insert a number equaling the pass intervals at which the end of pass message will be printed; e.g., every other pass, every third pass, etc.)

EXAMPLE:

Utilizing all the possible parameter changes, the STA command would look like this:

```
DS-A > STA/TESTS : 6/PASS : 2/  
FLAGS : IER : PNT : BOE : IDR/EOP : 3
```

With the RES command: Use TESTS, PASS, FLAGS, and/or UNITS to be tested; e.g., DS-A > RES/TESTS : 6/UNITS : 1 (this will run only test 6 on the device specified in "P" table 1)

With the other commands:

CON command: use PASS or FLAGS only

PRO command: use FLAGS only

DRO command: use UNITS only

DIS command: use UNITS only

ADD command: use UNITS only

PRI command: no variations

FLA command: no variations

ZFL command: no variations

CCI command: use TESTS, PASS, or FLAGS

B. Console Controls

1. Control "C" causes testing to cease and a return to the start (DS-A >).
2. Control "Z" causes default values to be taken in any of the three operator dialogues.
3. Control "O" causes a suppression of typeouts for the remainder of the diagnostic or until another control "O" is typed.

C. Hardware Questions

1. Supervisor's "P" (parameter) tables are built here, one for every unit to be tested.

2. "UNITS" pertains to the "P" table number, not the device unit number. If there is doubt as to which unit number has been assigned to which drive, the DIS command (see above) will supply the necessary information.

D. Software Question

CHANGE SW(L)? asks if any of the software parameters are to be changed. A "Y" will cause various questions to be asked. For more detail, refer to the individual program document.

