

digital

digital

digital

digital

digital

digital

digital

CS11-M  
MANUAL COMMUNICATIONS LINE  
SWITCH OPTIONS

OPTION DESCRIPTION  
CSS-MO-F-3.2-12

digital

**Computer Special Systems**

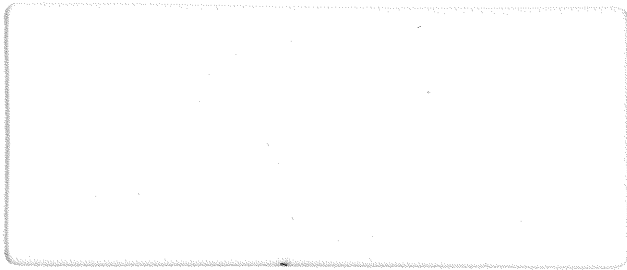

**NOTEBOOK SECTION**

3.2-12

**OPTION NUMBER**

-

**DRAWING SET NUMBER**

CS11-M

**PROGRAM NUMBER**

N/A

**DOCUMENT NUMBER**

CSS-MO-F-3.2-12

**REVISION**

C

**DATE**

JANUARY 1982

CS11-M  
MANUAL COMMUNICATIONS LINE  
SWITCH OPTIONS

OPTION DESCRIPTION  
CSS-MO-F-3.2-12

**digital**

**Computer Special Systems**

NASHUA

1st Printing October 1975  
2nd Printing (Rev) November 1976  
3rd Printing (Rev) March 1977  
4th Printing (Rev) September 1980  
5th Printing March 1981  
6th Printing January 1982

Copyright 1975, 1976<sup>©</sup>, 1977, 1980, 1981, 1982 by Digital Equipment Corporation

The material in this manual is for informational purposes and is subject to change without notice.

Digital Equipment Corporation assumes no responsibility for any errors which may appear in this manual.

Printed in U.S.A.

The following are trademarks of Digital Equipment Corporation, Maynard, Massachusetts:

DIGITAL	DECsystem-10	MASSBUS
DEC	DECSYSTEM-20	OMNIBUS
PDP	DIBOL	OS/8
DECUS	EDUSYSTEM	RSTS
UNIBUS	VAX	RSX
	VMS	IAS

## TABLE OF CONTENTS

1	INTRODUCTION . . . . .	1-1
1.1	General . . . . .	1-1
1.2	Operation . . . . .	1-2
2	INSTALLATION . . . . .	2-1
2.1	Site Considerations . . . . .	2-1
2.2	Cables . . . . .	2-2
2.2.1	CS11-MA/MB Switch Options . . . . .	2-2
2.2.2	CS11-MC/MD Switch Options . . . . .	2-3
2.2.3	CS11-MH/MJ Switch Options . . . . .	2-3
2.2.4	CS11-ME/MF Switch Options . . . . .	2-4
2.3	Checkout and Acceptance Procedures . . . . .	2-4
2.3.1	Checkout and Acceptance Procedure for CS11-MA/MB . . . . .	2-4
2.3.2	Checkout and Acceptance Procedure for CS11-MC/MD . . . . .	2-5
2.3.3	Checkout and Acceptance Procedure for CS11-MH/MJ . . . . .	2-5
2.3.4	Checkout and Acceptance Procedure for CS11-ME/MF . . . . .	2-6
2.4	Initial Operation . . . . .	2-6
2.4.1	Field Installation . . . . .	2-7
2.4.2	In-house Installation . . . . .	2-7
2.5	Related Literature . . . . .	2-7
3	OPERATION AND PROGRAMMING . . . . .	3-1
3.1	Controls and Indicators . . . . .	3-1
3.2	Programming . . . . .	3-1
4	THEORY OF OPERATION . . . . .	4-1
4.1	General . . . . .	4-1
4.2	CS11-MA/MB Building Module . . . . .	4-1
4.3	CS11-MC/MD Building Module . . . . .	4-2
4.4	CS11-MH/MJ Building Module . . . . .	4-3
4.5	CS11-ME/MF Building Module . . . . .	4-3
5	MAINTENANCE . . . . .	5-1
5.1	General . . . . .	5-1
5.2	Maintenance Techniques . . . . .	5-1
A	SHIPPING/ACCESSORIES LIST . . . . .	A-1
A.1	Equipment Furnished . . . . .	A-1
 Figures		
1-1	CS11 Switch Implemented in a Multiprocessor Configuration . . . . .	1-1
2-1	CS11 Switches, Dimensions, and Mounting Information . . . . .	2-1
2-2	CS11-MA/MB Cable Connections . . . . .	2-2
2-3	CS11-MC/MD Cable Connections . . . . .	2-3
2-4	CS11-MH/MJ Cable Connections . . . . .	2-3
2-5	CS11-ME/MF Cable Connections . . . . .	2-4
4-1	CS11-MA/MB Terminal Panel . . . . .	4-2
4-2	Rear View CS11-MC/MD . . . . .	4-2
4-3	CS11-MH/MJ Terminal Panel . . . . .	4-3
4-4	Rear View CS11-ME/MF . . . . .	4-4



## 1.2 OPERATION

The CS11 manually operated switches are constructed from basic building block modules which are rack mounted in a standard 19 inch x 5 1/4 inch mounting panel. Unused space in the mounting panel is filled with blank panels.

The four wire 20 mA current loop switches have screw-type terminal blocks on the rear panel, while the EIA standard RS-232-C switches are equipped with 25 pin interface connectors. The BELL TYPE 303 switch is equipped with 12 pin coaxial connectors. The units are supplied with the appropriate additional cables to connect to user specified devices.

### Manual Switch Options

- CS11-MA            Four-wire 20 mA current loop manual Fall-Back switch in four-channel sections. May also be used in EIA standard applications where only the four data lines are used. The CS11-MA consists of the first four-channel section mounted in a inch x 5 1/4 inch rack mounting panel. Three cables are provided per channel; two 18 foot cables terminated in male Mate-N-Lok connectors that attach to the communication interfaces and a 2 foot cable terminated in a female Mate-N-Lok connector that attaches to the device cable.
- CS11-MB            Four channel expansion module for the CS11-MA. Up to four CS11-MB expansion modules may be added to give a maximum of 20 channels in each CS11-MA. Cables are provided as above.
- CS11-MC            EIA standard RS-232-C manual Fall-Back switch in single channel sections. The CS11-MC consists of the first switch section in a 19 inch x 5 1/4 inch racking mounting panel. The CS11-MC is supplied with one 25 foot EIA standard cable to complete the connection to the device or modem.
- CS11-MD            Single EIA standard RS-232-C channel expansion module for the CS11-MC. Up to nine CS11-MD expansion modules may be added to give a maximum of 10 channels in each CS11-MC switch. The cable is supplied as above.
- CS11-ME            Wideband, Fall-Back switch in single-channel sections used for switching signals of wideband data sets such as BELL TYPE 303. The CS11-ME consists of the first switch section in a 19 inch x 5 1/4 inch rack mounting panel. The CS11-ME is supplied

CHAPTER 1  
INTRODUCTION

1.1 GENERAL

The CS11 family of switch options provides facilities for switching communication lines from one set of communication interfaces to another. These switch options are particularly useful in multiprocessor configurations (Figure 1-1) where one computer backs up another.

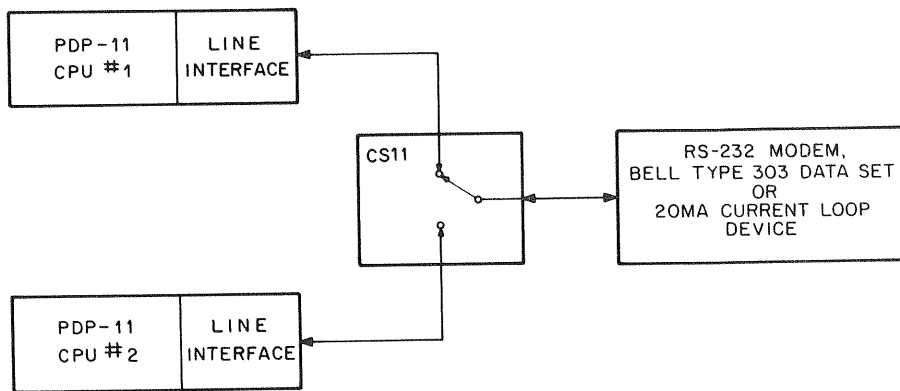

CS-1692

Figure 1-1 CS11 Switch Implemented in a Multiprocessor Configuration

The CS11 switches are offered for EIA standard RS-232-C, BELL TYPE 303, and four-wire 20 mA current-loop lines. These switches are compatible with either synchronous or asynchronous data lines and devices operating up to 460.8 KB/S.

An important CS11 feature is the use of special switches with bifurcated, gold-plated contacts which have been specifically designed for telephone and data line applications where maximum reliability and minimum signal degradation are important.

with one 20 foot wideband cable for connection to the modem.

- CS11-MF            Single wideband channel expansion module for the CS11-ME. Up to four CS11-MF expansion modules may be added, to give a maximum of 5 channels in each CS11-ME. The 20 foot cable is supplied as above.
- CS11-MH            Four-wire manual Fall-Back switch in four-channel sections. The CS11-MH consists of the first four-channel section mounted in a 19 inch x 5 1/4 inch rack mounting panel. Three cables are provided per channel to connect to DC14 type interfaces; two 5 foot cables terminated in male Mate-N-Lok connectors and a 10 foot cable terminated in a female Mate-N-Lok connector.
- CS11-MJ            Four channel expansion module for CS11-MH. Up to four CS11-MJ's may be added per CS11-MH. Cables are provided as above.
- CS11-MK            Sixteen Channel four wire 20 mA Fall-Back Switch. Consist of one CS11-MA and three CS11-MB's, including cables as described above.
- CS11-ML            Eight Channel EIA Standard RS-232-C manual Fall-Back Switch. The CS11-ML is comprised of one CS11-MC and seven CS11-MD's, including cables as detailed above.

NOTE

When specifying the above options, care must be taken to ensure that the interfaces to be used will have the proper cable termination (e.g., the DJ11-AC option is terminated on a distribution panel and BC04R-12 cables are necessary for connection to the CS11-MC/MD switch options).



CHAPTER 2  
INSTALLATION

2.1 SITE CONSIDERATIONS

The CS11 manually operated switches are installed in a standard 19 inch x 5 1/4 inch rack mounting panel (Figure 2-1). This panel(s) is mounted on the front of an H960 cabinet. The rack mounting panel which is included with either a CS11-MA, CS11-MC, CS11-ME, or CS11-MH, option contains 10 unit slots. A CS11-MA, CS11-MB, CS11-ME, CS11-MF, CS11-MH or CS11-MJ switch option requires two unit slots each. A CS11-MC or CS11-MD switch option requires one unit slot each. A CS11-MA, CS11-MC, CS11-ME, or CS11-MH, option must be provided for each 10 unit slots or additional fraction thereof required.

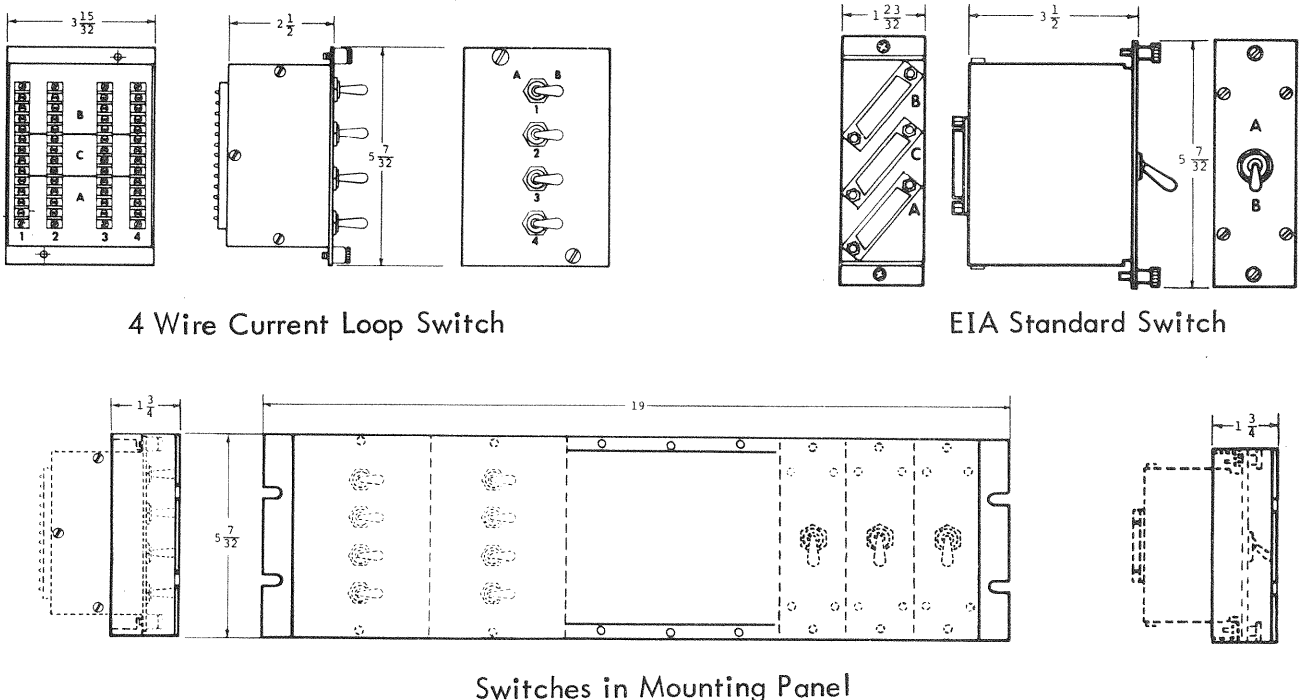

Figure 2-1 CS11 Switches, Dimensions, and Mounting Information

Environmental requirements for the CS11 switch options are the same as those specified for the PDP-11 computer system in the PDP-11 maintenance literature.

## 2.2 CABLES

The CS11 manual switch options are designed to connect either of two PDP-11 line interfaces to one communications terminal. The cable description for the 20 mA current loop line options (CS11-MA/MB), EIA, RS-232-C options (CS11-MC/MD) Bell Type 303 options (CS11-ME/MF) and DC14 switch (CS11-MH/MJ), are described separately in the following paragraphs.

### 2.2.1 CS11-MA/MB Switch Options

The CS11-MA/MB switch options for the 20 mA current loop lines are provided with three cables as shown in Figure 2-2. The 18 foot cable, terminated in a male Mate-N-Lok connector (DIGITAL P/N 12-09340-01), allows this option to connect to a PDP-11 line interface. The interface can be mounted in the same or adjacent cabinet and must be terminated in a female Mate-N-Lok connector (DIGITAL P/N 12-09340-00). The two foot cable allows the option to be connected to any communications terminal which is terminated in a male Mate-N-Lok connector. Therefore, with both female and male connectors available to the user, any interfaces and terminals with Mate-N-Lok connectors may be incorporated into a CS11 manual switch configuration by redirecting the existing cables. No additional or alternate cables are required.

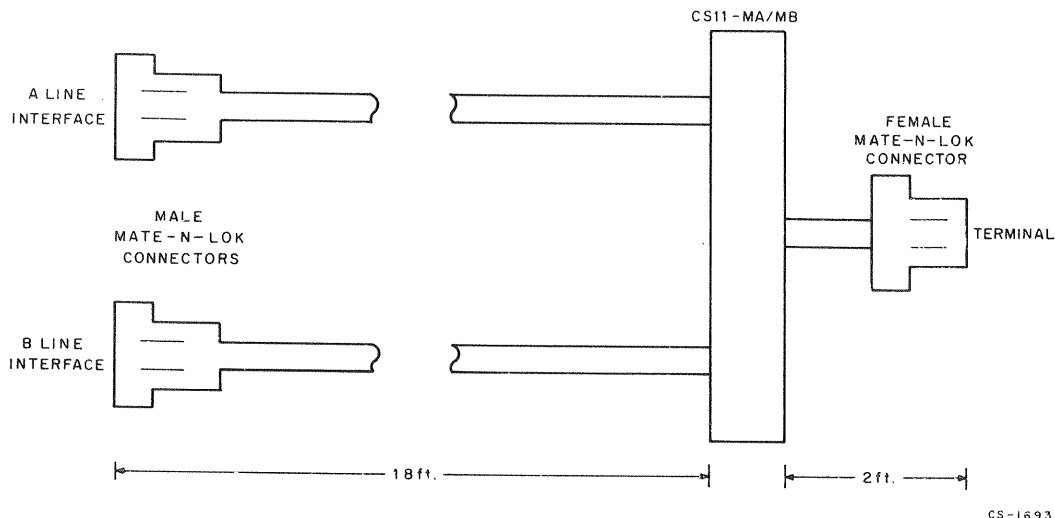

Figure 2-2 CS11-MA/MB Cable Connections

### 2.2.2 CS11-MC/MD Switch Options

The CS11-MC/MD switch options for the EIA standard RS-232-C interface lines are provided with two 25-pin (female) connectors. The CS11-MC/MD female connectors mate with the EIA standard male connector DB-25S (DIGITAL P/N 12-05886) which is provided at the end of a EIA cable associated with a PDP-11 line interface. Each CS11-MC/MD option is equipped with a 25 foot cable which provides the interconnection to the modem. Figure 2-3 illustrates the cable arrangement of the CS11-MC/MD options.

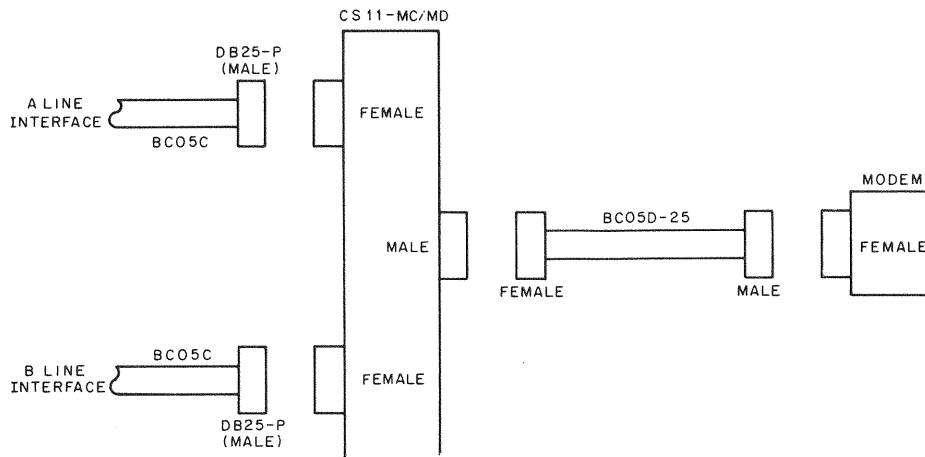

Figure 2-3 CS11-MC/MD Cable Connections

### 2.2.3 CS11-MH/MJ Switch Options

The CS11-MH/MJ switch options for BC14L type lines are provided with three cables shown in Figure 2-4. Two cables, terminated in male six pin connectors (mates with DIGITAL P/N 12-09350-06), allow the switch to be connected to DC14-CE channel interfaces. One cable, terminated in a female six pin connector (mates with DIGITAL P/N 12-09351-06), connects the switch with a DC14 controller interface through a BC14L cable. Four controller interfaces may be switched per CS11-MJ/MH.

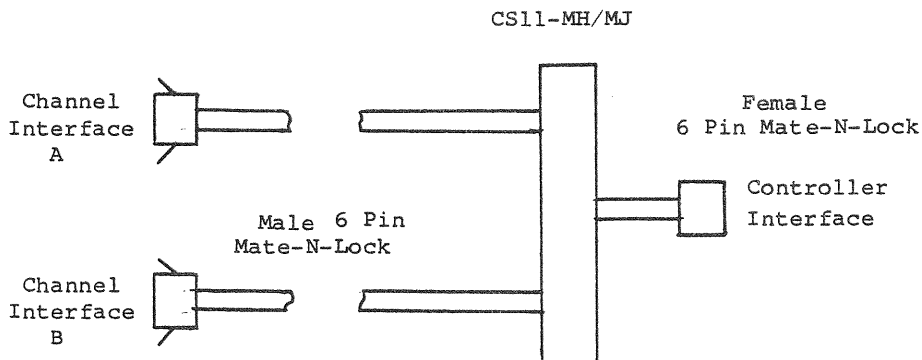

Figure 2-4 CS11-MH/MJ Cable Connections

### 2.2.4 CS11-ME/MF Switch Options

The CS11-ME/MF switch options for Bell Type 303 lines are provided with three 12-pin (female) coaxial connectors. These connectors mate with a plug, Burndy P/N MD 12 MXP-17TC. Each CS11-ME/MF option is equipped with a 20 foot cable which provides the interconnection to the modem.

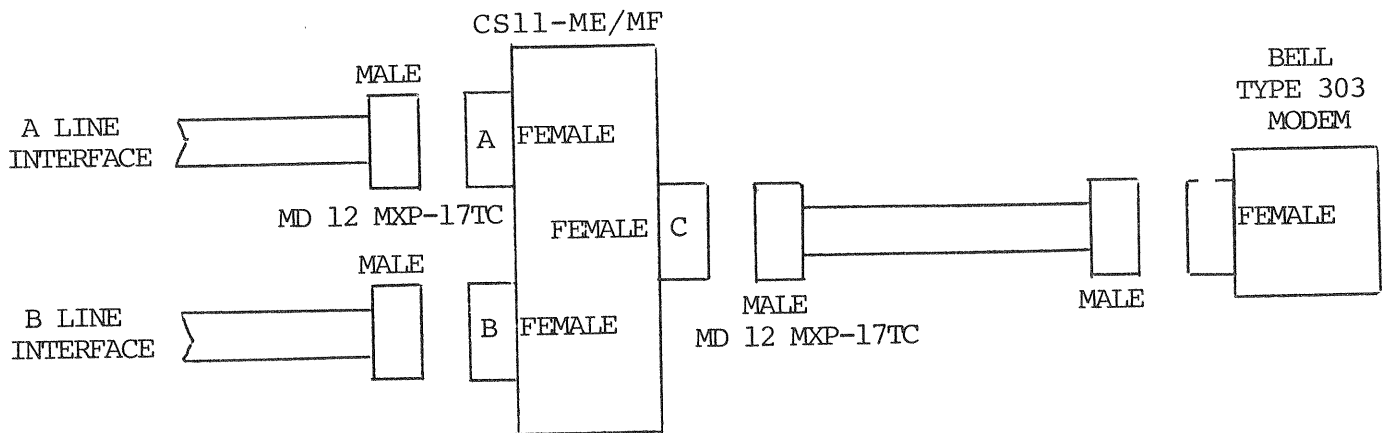

Figure 2-5 CS11-ME/MF Cable Connections

## 2.3 CHECKOUT AND ACCEPTANCE PROCEDURES

The following checkout and acceptance procedures are performed in-house prior to shipment of the CS11 manual switches.

### 2.3.1 Checkout And Acceptance Procedure For CS11-MA/MB

Using either the CS11-MA/MB test fixture or an Ohm meter, check for the following conditions:

- a. With the line switch in position A;

Verify that continuity exists from pins 2, 3, 5, and 7 of the line interface A connector, to pins 2, 3, 5, and 7 of the terminal connector respectively. Verify that continuity does not exist from pins 2, 3, 5, and 7 of the line interface B connector, to pins 2, 3, 5, and 7 of the terminal connector respectively.

- b. With the line switch in position B;

Verify that continuity does not exist from pins 2, 3, 5, and 7 of the line interface A connector, to pins 2, 3, 5, and 7 of the terminal connector respectively. Verify that continuity does exist from pins 2, 3, 5, and 7 of the line interface B connector, to pins 2, 3, 5, and 7 of the terminal connector.

Repeat this procedure for each line.

### 2.3.2 Checkout And Acceptance Procedure For CS11-MC/MD

Using either the CS11-MC/MD test fixture or an Ohm meter, check for the following conditions:

- a. With the line switch in position A;

Verify that continuity exists from pins 1-25 of the line interface A connector, to pins 1-25 of the modem connector respectively. Verify that continuity does not exist from pins 1-25 of the line interface B connector, to pins 1-25 of the modem connector respectively.

- b. With the line switch in position B;

Verify that continuity does not exist from pins 1-25 of the line interface A connector, to pins 1-25 of the modem connector respectively. Verify that continuity does exist from pins 1-25 of the line interface B connector, to pins 1-25 of the modem connector respectively.

### 2.3.3 Checkout And Acceptance Procedure For CS11-MH/MJ

Using either the CS11-MH/MJ test fixture or an Ohm meter, check the following conditions:

- a. With the line switch in position A;

Verify that continuity exists from pins 1, 3, 4, and 6 of channel interface A connector, to pins 1, 3, 4, and 6 of the controller interface connector. Verify that continuity does not exist from pins 1, 3, 4, and 6 of channel interface B, to pins 1, 3, 4, and 6 of the controller interface connector.

- b. With the line switch in position B;

Verify that continuity exists from pins 1, 3, 4, and 6 of channel interface B connector, to pins 1, 3, 4, and 6 of the controller interface connector. Verify that continuity does not exist from pins 1, 3, 4, and 6 of channel interface A connector, to pins 1, 3, 4, and 6 of the controller interface connector.

Repeat this procedure for each line.

#### 2.3.4 Check-out And Acceptance Procedure For CS11-ME/MF

Using an ohm meter, check for the following conditions:

- a. With the line switch in position A;

Verify that continuity exists between pins A-M (inner and outer conductors) of the line interface A connector, to pins A-M of the modem C connector, respectively. Verify that continuity does not exist from pins A-M of the line interface B connector to pin A-M of the modem C connector, respectively.

- b. With the line switch in position B;

Verify that continuity exists from pins A-M (inner and outer conductors) of the line interface B connector to pins A-M of the modem C connector, respectively. Verify that continuity does not exist from pins A-M of the line interface A connector to pins A-M of the modem C connector, respectively.

#### 2.4 INITIAL OPERATION

The following procedures should be performed at the time of installation.

### 2.4.1 Field Installation

When the CS11 manual switches are installed at the customer's site, perform the following:

- a. Repeat the checkout and acceptance procedure.
- b. Perform the checkout and acceptance procedure for the communication devices to be installed on the CS11 switch options.
- c. Install the CS11 manual switch options.
- d. Repeat the checkout and acceptance procedure for the communication devices installed on the CS11 manual switch options making certain to position the CS11 switch on the line interface under test.

### 2.4.2 In-house Installation

When the CS11 manual switches are installed on in-house systems, the initial turn-on procedure for each device connected to the CS11 manual switch should be performed. The operator must make certain to position the CS11 switch on the line interface under test.

## 2.5 RELATED LITERATURE

Title	Document Number
PDP-11 Processor Handbook	
PDP-11 Peripherals Handbook	EB-17560-20



## CHAPTER 3

### OPERATION AND PROGRAMMING

#### 3.1 CONTROLS AND INDICATORS

One manual switch is associated with each communication line controlled by the CS11 options. The switches are contained on a mounting panel located on the front of an H960 cabinet. Each CS11-MA/MB and CS11-MH/MJ option contains four switches, providing the facility to switch four communication lines. The CS11-MC/MD, CS11-ME/MF options contain one switch and control one line. The positions on all switches are marked A and B, indicating which line interface is connected to the terminal device.

#### 3.2 PROGRAMMING

No programming procedures are associated with the CS11 manual switch options. The operator must inform the operating software of any change in the switch settings.



## CHAPTER 4

### THEORY OF OPERATION

#### 4.1 GENERAL

The CS11 manually operated switches consist of basic building block modules. The basic module used for the CS11-MA/MB and CS11-MH/MJ options consists of four 4-pole double throw switches. The module used for the CS11-MC/MD options consist of one 25-pole double throw switch. The module used for the CS11-ME/MF options consist of one 24-pole double throw switch.

Each switch contact is configured to connect one logic signal of the terminal device to either line interface A or line interface B. Sufficient switch contacts are ganged (four for the CS11-MA/MB and CS11-MH/MJ, 25 for the CS11-MC/MD) to allow all logic signals for one communication line to be controlled from the single switch arm.

#### 4.2 CS11-MA/MB BUILDING MODULE

The CS11-MA/MB building module consists of four, 4-pole switches. Each switch unit controls one 4-wire, 20 mA current loop circuit. The back panel of the CS11-MA/MB module contains 48 screw terminals as shown in Figure 4-1. One end of the CS11-MA/MB cables connect to the screw terminals; the other end terminates in a Mate-N-Lok connector. Each vertical row of screw terminals provide the connections necessary for one communication line. The four terminals in area A connect to the line interface A cable, the four terminals in area B connect to the line interface B cable, and the four terminals in area C connect to the communication terminal cable. The four screw terminals of each area from top to bottom are connected to pins 2, 3, 5, and 7 respectively of their associated Mate-N-Lok connectors.

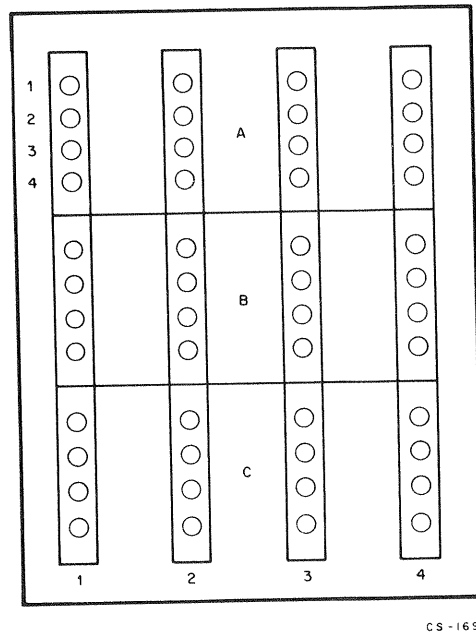

CS-1691

Figure 4-1 CS11-MA/MB Terminal Panel

#### 4.3 CS11-MC/MD BUILDING MODULE

The CS11-MC/MD building module consists of one 25-pole double throw switch which switches each pin of the EIA RS-232 male output connector to either the A or B female input connector. The female connectors A and B of the building module join with the standard EIA line interface connector. The CS11-MC/MD (Figure 4-2) is supplied with a BC05D-25 cable which allows the building module (male connector C) to connect to a modem.

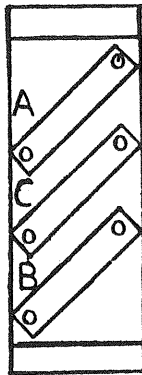

Figure 4-2 Rear view CS11-MC/MD

#### 4.4 CS11-MH/MJ BUILDING MODULE

The CS11-MH/MJ (Figure 4-3) building module consists of four, 4-pole switches, physically identical to the CS11-MA/MB. Cables supplied with the CS11-MH/MJ connect to the CS11-MH/MJ screw terminals on one end. Six pin Mate-N-Lok connectors terminate the opposite end.

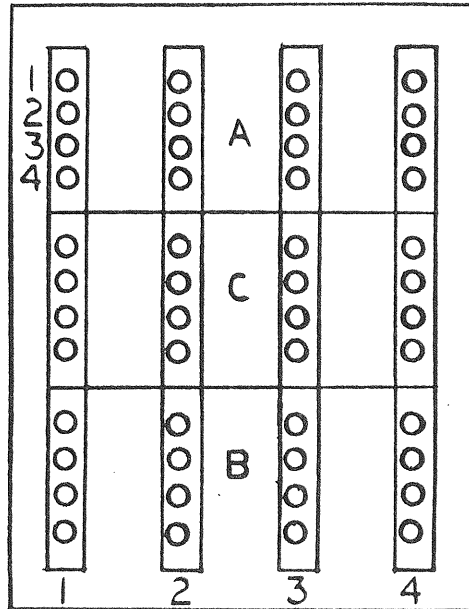

Figure 4-3 CS11-MH/MJ Terminal Panel

#### 4.5 CS11-ME/MF BUILDING MODULE

The CS11-ME/MF Building Module consists of one 24-pole double throw switch which switches each pin of the female output modem connector C to either the A or B line interface input connectors. The CS11-ME/MF (Figure 4-4) is supplied with a 20 foot cable which allows the Building Module to connect to a modem.

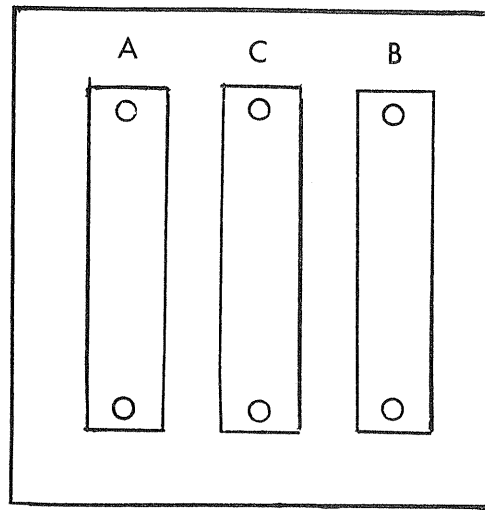

Figure 4-4 Rear View CS11-ME/MF

## CHAPTER 5

### MAINTENANCE

#### 5.1 GENERAL

No special tools or test equipment are required for maintaining the CS11 manual switch options. Margin tests are not performed on this device. Maintenance tests performed on the line interface units and the terminal devices through the CS11 switches verify the switch operation.

#### 5.2 MAINTENANCE TECHNIQUES

If a problem develops on a communication line associated with a CS11 manual switch, check to see if the switch has the proper line interface selected and that all cables are properly installed. If the CS11 option is still suspect after making these visual checks, the switch may be removed from the communication line. The cable from the line interface under test and the cable from the communication terminal can be removed from the switch and connected directly together. If the communication device then works properly, the problem is due to the CS11 option. Performing the checkout and acceptance procedure should isolate the problem area.









4

4



4

4



**digital**

**Computer Special Systems**