

VAX 7000 Systems

High-performance, powerful I/O, and great expansion for enterprise solutions

When performance is optimum to your business, consider the new VAX 7000 Model 700 SMP systems. High performance, powerful I/O, and great expansion for enterprise solutions—from 314 to over 1,000 TPS of performance.

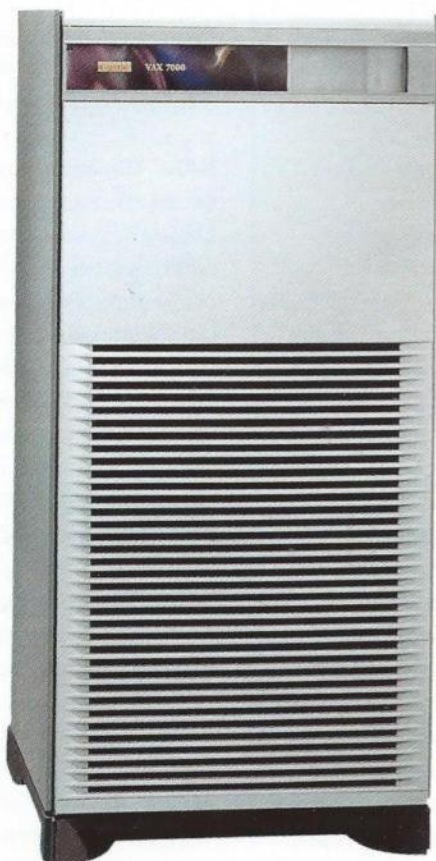

VAX 7000 systems are high-performance, OpenVMS based systems designed for the rigorous demands of enterprise computing. You can depend on them for business-critical applications that previously required a mainframe, applications such as transaction processing, order entry, general ledger, and securities trading. If a production system is needed to run your business, your application can be downsized on a VAX 7000 Model 700 system for high performance at low cost.

These high-reliability systems will grow as your needs grow. The modular platform enables you to improve performance in virtually all dimensions—symmetric multiprocessing, larger memory, more I/O bandwidth, greater disk capacity, and OpenVMS Cluster systems, all while building upon your current investments. And Digital's track record of reliability, service, and support ensures that your system will provide continued satisfaction.

The best path to the future
Digital's VAX 7000 systems not only enable you to solve today's pressing data center challenges, they prepare you to solve tomorrow's challenges too. With a simple swap of the processor board, today's VAX systems can become the VAX or Alpha AXP data center system you need tomorrow. Your investments in training, software, and peripheral hardware, including memory, I/O controllers, disk, and terminals, are protected.

Highlights

- **Best path to the future with easy Alpha AXP upgrades**

- **Standards-based application powerhouse**

- **Exceptional price and performance**

- **Total data protection**

- **Advanced software functionality**

- **New family packaging**

Standards-based application powerhouses

The VAX 7000 system is optimally suited for all commercial applications and all major industries. The Model 700 systems support massive databases, VLDB (Very Large Database), and high-volume transactions. These systems offer superior price/performance benefits to organizations that are:

- Processing high-volume transactions or large-scale commercial batch jobs

- Exploring downsizing and other ways to reduce mainframe costs

- In need of network support for distributed operations

- Easy migration to Alpha AXP technology in the future

The VAX 7000 Model 700 system can support hundreds of PCs or workstations running a wide range of applications. Because Digital's client/server computing is built on standards-based Network Application Support (NAS) software, these VAX servers support OpenVMS, ULTRIX, UNIX®, MS-DOS®, OS/2® and Macintosh® clients, and both windowing and ASCII terminals.

The cost of running your applications on these data center systems is less than one-tenth the cost of running them on yesterday's mainframe systems—with no loss of performance or responsiveness. And Digital can make it easy for you to move your mainframe applications onto an OpenVMS system: we have the tools, services, and expertise to help downsize your computing environment.

With these powerhouses, rest assured your most crucial transactions will execute quickly and with full integrity.

Exceptional price and performance

The VAX 7000 system gets its fast processing power from a design that takes VAX instructions, translates them into RISC operations, and then executes them in a very high performance, four-stage RISC pipeline. Each powerful CPU runs at 137.5 MHz—a level of performance that can transform the way your business runs. The ability to configure a symmetric multiprocessing VAX system with as many as six CPUs offers yet another dimension of performance.

Fast processors are only one part of these powerful solutions.

To balance the processor performance, these systems have been designed to support very high volume I/O. A high-speed system interconnect links memory and processors, allowing a sustained system bandwidth of 640 MB/sec. For peripheral devices, these VAX systems support as many as four 100 MB XMI I/O channels—for an aggregate bandwidth of 400 MB. And since many of Digital's XMI based I/O controllers are powered by RISC chips, high system throughput is bolstered at every point.

Measured in terms of full-system transaction processing benchmarks, today's VAX data center systems meet or beat the most competitive price/performance figures in the industry.

For example, the VAX 7000 Model 710 system provides an estimated 314 TPS of performance, while the VAX 7000 Model 760 achieves 1,004 TPS.

Total data protection

These VAX systems are designed for the high reliability your business-critical applications require. The CPU technology is based on Digital's proven CMOS technology, and full error protection is provided on the system bus, all memory modules, and the write-back cache. They provide power conditioning to protect against high-voltage transients.

Systems can be configured with an optional N+1 redundant power system (up to three power regulators), ensuring that even the most heavily configured system has sufficient redundant power to keep

operating in the event of a power regulator failure. System level UPS (Uninterruptible Power System) and PCS (Power Conditioning System) capability is also available on the VAX 7000 system to protect against downtime in the event of a power outage.

Advanced software functionality

Digital's OpenVMS operating system is based on standards—standards for software development, networking and communications, system management, data management, and user interaction. With standards, OpenVMS brings superior functionality to an open system. OpenVMS standards include IEEE, POSIX, X/Open™ BASE Branding (XPG4), and Motif®. In addition, Digital supports the Open Software Foundation's (OSF®) Distributed Computing Environment (DCE).

NAS: Digital's commitment to multivendor integration

Digital's commitment to NAS and standards-based open computing means applications can be integrated and shared over your network and across a broad range of industry-standard, heterogeneous systems. NAS 400 offers one of the most highly acclaimed transaction processing capabilities in the industry, an enhanced business-critical environment, application and desktop integration, and access to functions such as disk shadowing, journaling, and transaction processing. NAS 400 on an OpenVMS Cluster provides the highest level of data center support.

Industry leadership I/O support

VAX 7000 Model 700 systems now support the VAX BI and VME bus adapter. This provides access to thousands of third-party devices as well as selected VAX BI devices. This I/O device support enhances the openness of the VAX 7000 Model 700 systems.

The VAX 7000 is the most expandable I/O server in the industry including support of up to:

- 8-FDDI interfaces
- 8-VME bus adapters
- 16-Ethernet
- 10-CI Cluster interconnect

Most expandable enterprise system in its class

VAX 7000 systems provide outstanding growth capability. Support for up to six CPUs and up to seven memory arrays enables you to configure large systems to suit a wide variety of needs.

These systems support up to 3.5 GB of memory—and expand up to 14 GB as you upgrade to an Alpha AXP system. You can configure up to 42 GB of storage and 2.6 GB of tape capacity in the VAX 7000 system cabinet to form a complete, compact system. Outside the cabinet you can store up to 500 GB additional DSSI storage and more than 10 terabytes of storage in a CI-bytes environment.

High Performance I/O Device Support

	Function	XMI Device	# per SMI	# per System	Performance per XMI Device
Network Adapters	NI	DEMNA	4	16	10 Mbits/sec
	FDDI	DEMFA	4	8	10 MB/sec
Storage Adapters	CI	CIXCD	4	10	8 MB/sec
	SI	KDM70	3	12	4 MB/sec
	DSSI	KFMSA	5	12	5.5 MB/sec
Bus Adapters	VME Bus	DWMVA	8	8	1-10 MB/sec
	VAXBI Bus	DWMBA	2	6	10 MB/sec

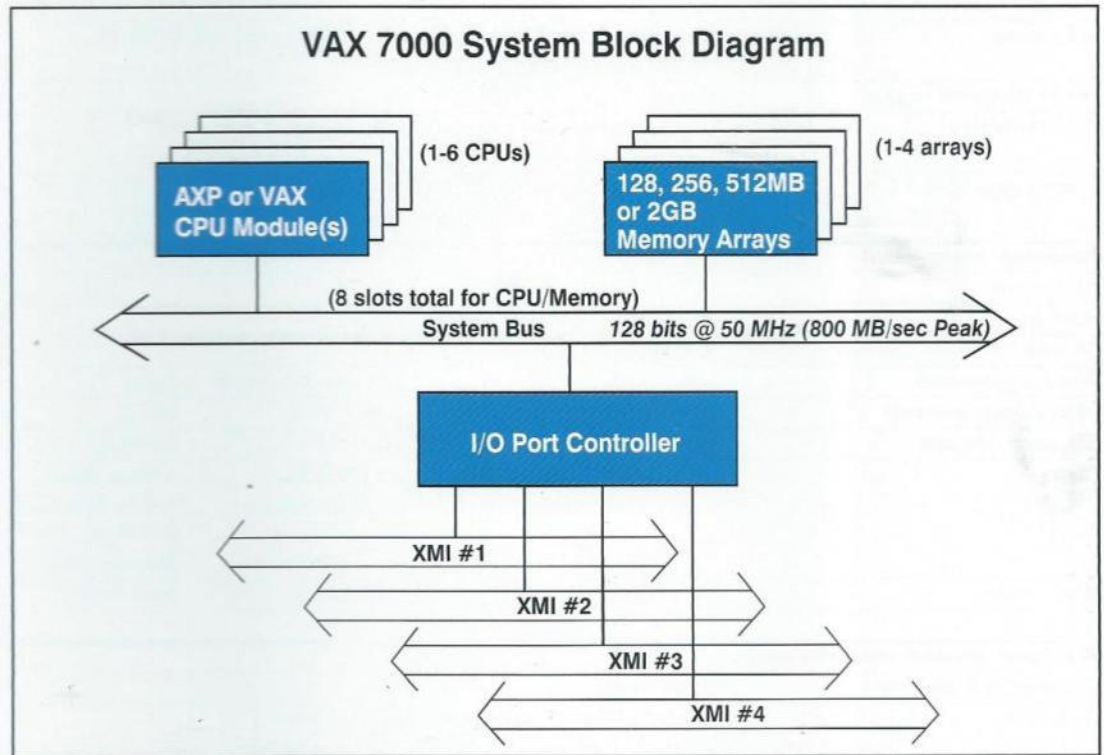

A variety of configurations

VAX 7000 systems combine outstanding growth capability with optimum configuration flexibility. VAX 7000 ADVANTAGE-SERVER based systems offer package-priced, balanced configurations complete with memory, I/O controllers, disks, tape, and

Network Application Support (NAS) 200 software. They also give you the flexibility to add components as needed, including user licenses, additional memory, and disks.

VAX 7000 Specifications

Model	710	720	730	740	750	760
Performance (TPS)	314	-	-	-	-	1,004
Number of processors	1	2	3	4	5	6
CPU clock speed	137.5 MHz/processor					
Cache size	10 KB on chip/processor; 4 MB on board/processor					
In-cabinet CPU upgrade	Systems can be upgraded to symmetric multiprocessing VAX CPUs and to current or future generation Alpha AXP CPUs					
High-speed system interconnect	640 MB					
Max. memory capacity	3.5 GB					
Max. disk capacity (in-cab/total)	42 GB/Over 10 TB					
Max. I/O bandwidth	400 MB/s					
I/O support	XMI (4); CI (10); DSSI (24); SDI/STI (12); Ethernet (16); FDDI (8); VAXBI (6); VME (8)					
OpenVMS cluster support	Ethernet, DSSI, CI, FDDI					
High availability	Disk Shadowing, N+1 Redundant Power System, Integrated Uninterruptible Power System (UPS),					
Features supported	Battery Backup, Built-in Power Conditioning					

Operating environment

Temperature	15°C-28°C (59°F-82°F)			
Humidity	10%-90%			
Altitude	2,400 m (8,000 ft)			
Power requirements	U.S./Canada	Europe/Asia/Pacific	Japan	
Input voltage (nominal)	120/208 V	380/415 V	202 V	
Frequency tolerance	50-60 Hz	50-60 Hz	50-60 Hz	
Phases	3 Phase Star, 4 Wire N-Gnd	3 Phase Star, 4 Wire N-Gnd	3 Phase Delta, 4 Wire Mid-Gnd or 3 Wire Junction-Gnd	
Surge current	50 A Peak	50 A Peak	50 A Peak	

VAX 7000 physical characteristics

Maximum heat dissipation	17,700 Btu/h
Dimensions	Height: 170 cm (67 in), Width: 80 cm (31.5 in) Depth: 87.5 cm (34.4 in), Weight: 448 kg (1000 lb)

Exceptional service and support

Digital supports the VAX 7000 systems with a full range of system management, network management, training, administration, recovery, and support services to meet your individual needs.

Call us

For further information on the VAX 7000 series of complete business computing solutions or specific service information, please contact your local Digital Sales Representative or Authorized Business Partner.

Digital believes the information in this publication is accurate as of its publication date; such information is subject to change without notice. Digital is not responsible for any errors in the information given in this publication. Digital conducts its business in a manner that conserves the environment.

The following are trademarks of Digital Equipment Corporation: Alpha AXP, AXP, CI, the DIGITAL logo, DSSI, OpenVMS, ULTRIX, VAX, VAXBI, and XMI.
Third-party Trademarks:
OS/2 is a registered trademark of International Business Machines Corporation. Macintosh is a registered trademark of Apple Computer, Inc. UNIX is a registered trademark of UNIX System Laboratories, Inc. MS-DOS is a registered trademark of Microsoft Corporation. Motif and OSF are registered trademarks of Open Software Foundation, Inc. X/Open is a trademark of X/Open Company Limited.