

ESE20 Solid State Disk

High-Performance I/O Subsystem for Maximum System Utilization

digital



The Electronic Storage Element (ESE20) is the premier member of a new class of storage systems—Digital's Solid State Disk family—designed to boost the performance of standalone and VAXcluster Systems performing I/O-intensive computing applications.

The ESE20 is 120 Megabytes of solid state memory configured as a nonvolatile, DSA-compliant disk device. It places the power of state-of-the-art DRAM technology at your command as a high-performance I/O subsystem capable of servicing hundreds of I/O requests per second—many times that of a magnetic disk—while offering all the advantages of conventional storage.

In such applications as transaction processing, large population timesharing, and I/O-intensive scientific analysis, the ESE20 is capable of providing dramatic improvements in elapsed time, system throughput, response time, batch run completion time, and maximum user count.

If full utilization of your VAX System CPU power is limited by the I/O speed of your storage subsystems, then adding the ESE20 to your storage hierarchy can reduce and eliminate I/O bottlenecks. The ESE20 is the perfect complement to large-capacity magnetic disks for storage of frequently accessed shared files such as system disk, index, and control files.

The ESE20's Standard Disk Interface allows you to put it into immediate use in your VAX System computing environment without operating system or software modification. And its Data Retention System provides maximum protection of your critical data.

Combining DRAM speed with the primary benefits of magnetic storage devices—flexibility and nonvolatility—the ESE20 is the ideal choice for VAXcluster Systems and standalone computing environments requiring high-performance I/O.

Highlights

- I/O performance in excess of 300 requests per second, over 10 times greater than the average number of request-per-second service by a magnetic disk
- A random-access storage device that uses 1-Mbit DRAM technology
- 120 Megabytes of storage in each ESE20 unit; multiple ESE20s can be linked to support bound volumes for files greater than 120 MB under VMS
- DSA-compliance ensures quick and easy installation in computing environments without software or application modification
- Built-in Data Retention System provides safe, reliable nonvolatile data storage
- Shadowing, dual-port connectivity, VAXsimPLUS fault monitoring provide superior system availability for critical applications
- Dual-level error detection and correction—Hamming ECC code at the board level, and Reed-Solomon ECC at the controller level—provide superior data integrity
- Familiar RA disk drive control panel permits easy operation; RUN/LOAD switch allows manual save-and-restore capability for easy service and maintenance
- Packaged in a 60-inch-high storage array cabinet. Each cabinet can hold one or two ESE20s, each with its own Data Retention System.

Closing the I/O Performance Gap

In recent years, improvements in CPU compute speeds have generally outpaced increases in the speeds of I/O subsystems.

Now you can put DRAM technology to work for you to close the performance gap between the VLSI CPU power of your Digital processors and the I/O speeds of your traditional magnetic disk drives.

Digital's ESE20 solid state disk is a high-performance I/O subsystem that combines the almost instantaneous access speed of main memory with all of the traditional advantages of magnetic disks.

Packaged as a standalone DSA-compliant device, Digital's solid state disk uses standard disk interconnects and access methods. This means you can easily install the ESE20 within your existing storage hierarchy without software or operating system modification. Programmer and system managers do not have to change the way they view and manage storage. Adding the ESE20 will not disrupt daily operations.

The ESE20's internal Data Retention System provides safe, reliable nonvolatile protection of your data. In applications where data is difficult or impossible to regenerate, nonvolatility is an essential requirement.

Eliminating I/O Bottlenecks

To determine whether a solid state disk will improve your system performance, you must evaluate the I/O intensity of your computing environment.

"Hot File" I/O Bottlenecks

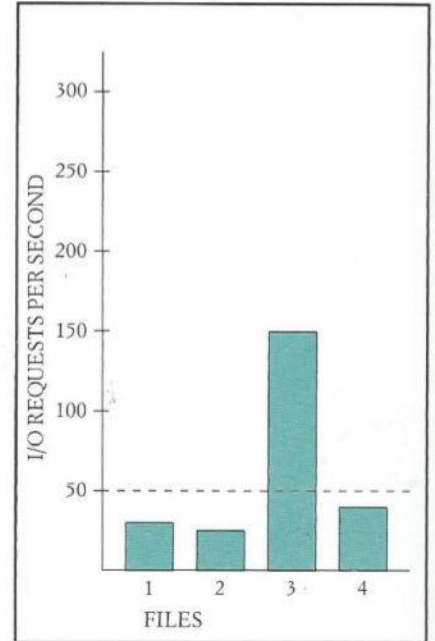

In some environments, I/O bottlenecks are caused by constant access to relatively small amounts of data, such as control, journal, and index files, known as "hot files."

Digital offers a variety of system analysis tools—the VAX Performance Advisor (VPA version 2.0), the System Performance Monitor (SPM), and the VMS MONITOR—to help you identify and characterize I/O bottlenecks.

In general, if your standalone or VAXcluster system is experiencing CPU utilization of less than 70 percent, I/O queues larger than 2, and I/O request rates greater than 30 per second, the ESE20 solid state disk may be the key to dramatically improving system performance.

ESE20 Internal View

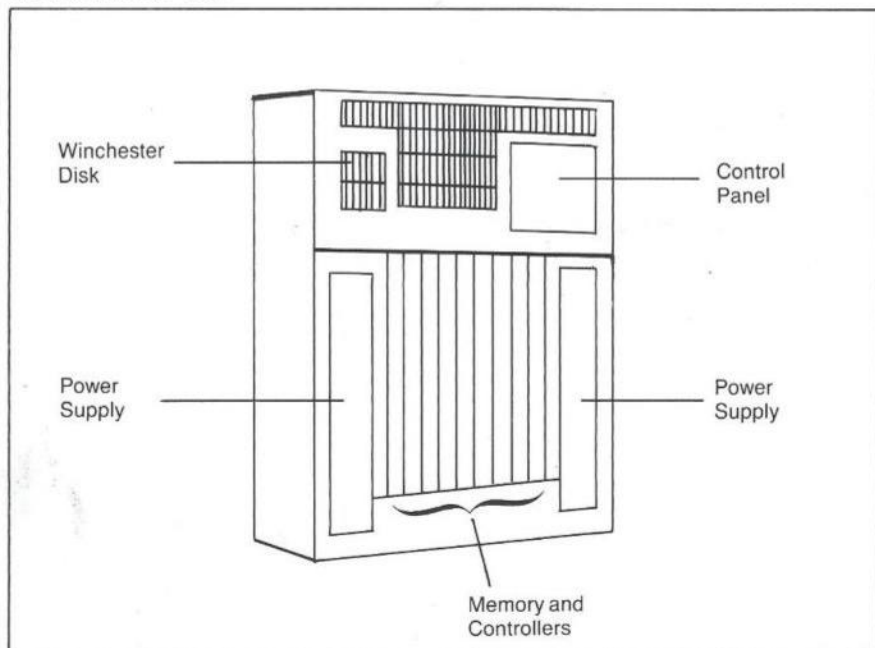

Timesharing Advantages—Add More Users without System Degradation

The ESE20 can be added to your VMS or ULTRIX operating system computing environment without operating system or software modification. In many cases, hardware solutions are often easier and less expensive than software solutions.

The ESE20 can be used as a VMS system disk, to store heavily accessed files such as JBCSYSQUE.DAT, RIGHTSLIST.DAT, and SYSUAF.DAT. You can also store DBMS index and journal files on solid state disk to produce significant network performance improvement.

Storing the master index files of an Electronic Messaging System on an ESE20 enabled a telecommunications system to expand its user base from

125 to 400—based on predictive modeling—without response time degradation. This constitutes a user population increase of over 200 percent.

In a Computer Integrated Manufacturing application, RMS indexed data files were moved to solid state disk. This produced a significant performance boost, providing alternative benefits of either a 43 percent improvement in job completion time, or the ability to add 47 percent more users to the system.

Improve Engineering Productivity in Scientific Applications

Benchmarks of synchronous I/O scientific applications such as PATRAN™ Finite Element Analysis indicate that elapsed runtimes can be reduced up to 80 percent by moving data and output files to solid state disk. Benchmarks running five different FEA applications produced an average performance boost of 44 percent.

Similar results were obtained on a quantum chemistry application running on a standalone processor. Substituting ESE20s for magnetic disks to store user files produced an average 31 percent improvement in job completion time according to a Gaussian 82 Chemical Analysis benchmark.

Safe, Dependable Nonvolatile Storage

Unlike alternative solid state disks, the ESE20 provides nonvolatile data storage. In the event of a power failure, its Data Retention System and standby power system provide complete data security.

The ESE20 senses any interruption of power, automatically switches over to its standby power system, and transfers the contents of its memory arrays onto an internal Winchester disk. The backup process takes approximately 12 minutes.

When AC power is restored, the ESE20 is online in 135 seconds. Data is returned to the solid state disk in approximately 12 minutes without operator intervention. The ESE20 is online during the restoration period, servicing I/O requests at a reduced rate. Data is restored and retrieved from the solid state disk in the order it is requested by the disk controller.

The standby power system provides AC power for the ESE20 device for approximately 12 minutes after loss of AC power. This prevents loss of ESE20 data while it is unloaded onto the Data Retention System. One standby power system can support two ESE20 devices. It can perform two data retention cycles in a 16-hour period, after which a 12-hour recharge period is necessary.

During normal operation, the Data Retention System performs diagnostics and monitors itself. If a failure is detected, the host is informed, and you may manually choose to write-protect the ESE20.

Switches on the ESE20 operator's control panel allow you to take the system off-line for service or maintenance without loss of data. Dual ports allow flexible connectivity and operating convenience.

Optimum Data Integrity

Dual-level Error Correction Code provides maximum reliability and data integrity on the ESE20. Hamming Code in the memory boards detects double-bit errors and corrects single-bit errors in each storage word. Reed-Solomon block Error Correction Code generated by HSC, KDA, or KDB controllers detects and corrects errors that are uncorrected by the Hamming Code.

This two-level ECC scheme provides three times the data integrity of Hamming Code alone. This translates to over a hundred thousand hours of operation (11 years) between uncorrectable errors.

VAXcluster System Configuration

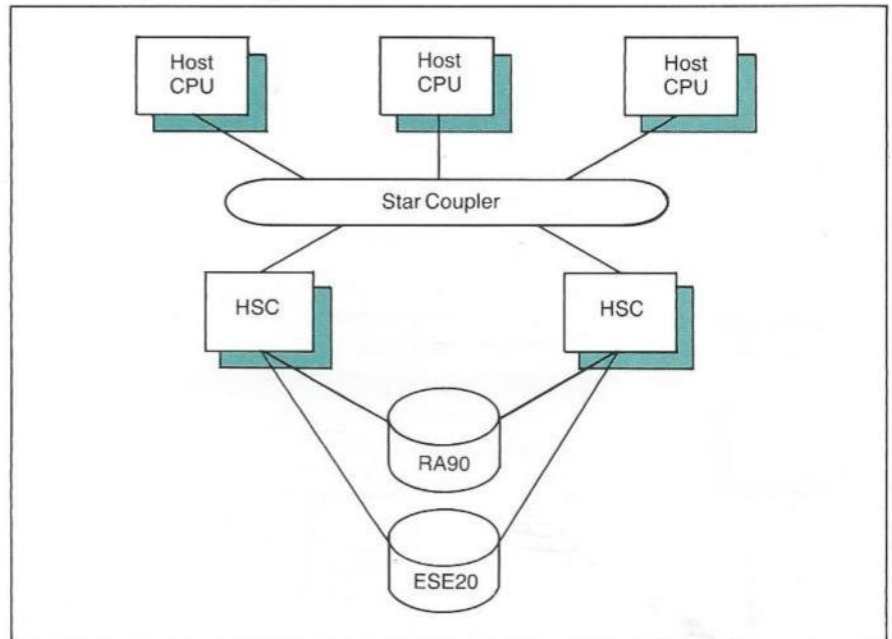

Device error logging reports error types, locations, and times in addition to other system status information. When an error occurs, the ESE20 device informs the host, so you can take appropriate action promptly.

Overall I/O subsystem protection and data availability are further assured by VAXsimPLUS support for ESE20. VAXsimPLUS is a knowledge-base VMS layered product capable of predicting failure in a storage subsystem. By constantly monitoring storage devices, VAXsimPLUS tracks errors, indicating need for service before failure.

All the Pieces Fit

The ESE20 complements large capacity magnetic disk devices by providing a smaller but much faster storage alternative for frequently used files.

The ESE20 subsystem is DSA-compatible, ready to configure within your existing storage hierarchy without disrupting your operations. The ESE20 is supported by HSC (v3.9 microcode) and KDA/KDB DSA controllers, ready to be directly connected to a standalone system or integrated within a VAXcluster System.

The standby power system provides AC power for the ESE20 device for approximately 12 minutes after loss of AC power. This prevents loss of ESE20 data while it is unloaded onto the Data Retention System. One standby power system can support two ESE20 devices. It can perform two data retention cycles in a 16-hour period, after which a 12-hour recharge period is necessary.

During normal operation, the Data Retention System performs diagnostics and monitors itself. If a failure is detected, the host is informed, and you may manually choose to write-protect the ESE20.

Switches on the ESE20 operator's control panel allow you to take the system off-line for service or maintenance without loss of data. Dual ports allow flexible connectivity and operating convenience.

Optimum Data Integrity

Dual-level Error Correction Code provides maximum reliability and data integrity on the ESE20. Hamming Code in the memory boards detects double-bit errors and corrects single-bit errors in each storage word. Reed-Solomon block Error Correction Code generated by HSC, KDA, or KDB controllers detects and corrects errors that are uncorrected by the Hamming Code.

This two-level ECC scheme provides three times the data integrity of Hamming Code alone. This translates to over a hundred thousand hours of operation (11 years) between uncorrectable errors.

VAXcluster System Configuration

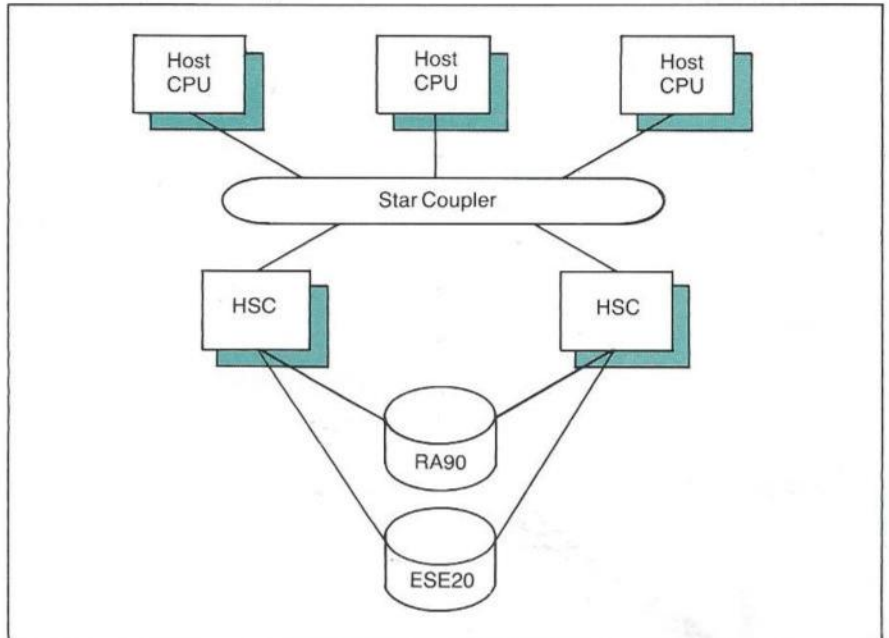

Device error logging reports error types, locations, and times in addition to other system status information. When an error occurs, the ESE20 device informs the host, so you can take appropriate action promptly.

Overall I/O subsystem protection and data availability are further assured by VAXsimPLUS support for ESE20. VAXsimPLUS is a knowledge-base VMS layered product capable of predicting failure in a storage subsystem. By constantly monitoring storage devices, VAXsimPLUS tracks errors, indicating need for service before failure.

All the Pieces Fit

The ESE20 complements large capacity magnetic disk devices by providing a smaller but much faster storage alternative for frequently used files.

The ESE20 subsystem is DSA-compatible, ready to configure within your existing storage hierarchy without disrupting your operations. The ESE20 is supported by HSC (v3.9 microcode) and KDA/KDB DSA controllers, ready to be directly connected to a standalone system or integrated within a VAXcluster System.

Standalone System Configuration

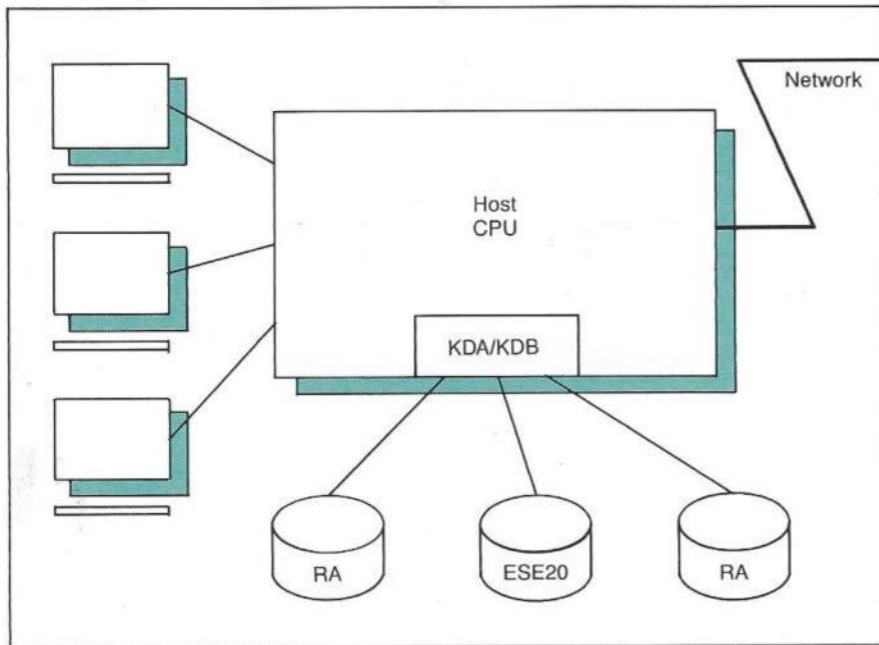

Unlike solid state disks that require inefficient protocol adapters, you can attach the ESE20 to Digital controllers using Digital's native-mode SDI interface. That's why Digital solid state disks offer up to double the price/performance of other hardware alternatives.

Maximizing Your Computing Investment

Now you can achieve superior VAXcluster and standalone system performance with Digital solid state disk technology.

And Digital's system analysis products—the VAX Performance Advisor, the System Performance Monitor, and the VMS Monitor—let you clearly measure the improvement.

The ESE20's DSA-compliance provides maximum investment security. As a member of Digital's storage family, the ESE20 provides you with valuable flexibility in planning and managing your computing resources as they change and evolve.

Solid state disk technology provides a very flexible solution that can be effective in a variety of environments. It is especially well suited to the VAXcluster System environment because it efficiently supports sharing among multiple hosts. But it is also beneficial in standalone computing environments in which I/O throughput hampers full CPU utilization.

Unlike various software alternatives, the ESE20 solid state disk provides increased I/O performance without requiring sequestering of portions of

valuable main memory from active use for special treatment by the CPU. Nor does it cost you CPU cycles. It is the optimum solution to I/O bottlenecks.

Digital's premier ESE20 solid state disk offers you an unprecedented opportunity to take advantage of the unused power in your standalone VAX or VAXcluster system.

One-Year Warranty

Your ESE20 is covered by a one-year warranty that includes parts and labor. It is backed by one of the most respected and prestigious field service organizations in the industry. Digital offers a variety of flexible service programs, a range of software support and consulting services, and education services to help your organization get maximum value from this high-quality product.

When you invest in advanced new computer technology, you want to do so with a company you can trust; a company that can commit resources to provide support for your product for as long as you own it.

For More Information

For more information about how Digital's solid state disk ESE20 fits in your organization's storage strategy, contact your local Digital Sales Representative today.

Specifications

Performance

Peak transfer rate	2.5 MB/second
Spiral transfer rate	1.8 MB/second
Average latency	528 microseconds
Seek time	<1 millisecond
Unit start-up	135 seconds

Data Organization

Formatted capacity	245,760 sectors 120 MB data, 8 MB overhead
Drive geometry	480 cylinders 128 tracks per cylinder 4 sectors per track

Operating Environment

Temperature range	15°–32° C (59°–90° F)
Relative humidity	20% to 80%
Max wet bulb	25° C (77° F)
Min dew point	2° C (36° F)
Max altitude	8,000 ft above sea level
Max acoustic noise	45 dBA

Power Requirements

Standards	UL listed; CSA certified; FCC Class A verified
Voltage	120/208 V AC at 60 Hz; 3-phase WYE 220/240 V AC at 50 Hz

Max heat dissipation:

Single ESE20-AA; ESE20-AB	500 W
Double ESE20-BA; ESE20-BB	875 W
Power plug	NEMA L21-30P

Physical Dimensions

Height	152.4 cm (60 in)
Width	72.7 cm (29 in)
Depth	91.4 cm (36 in)
Shipping weight <i>(Two ESE20s in cabinet)</i>	335.7 kg (746 lb)
Installed weight <i>(Two ESE20s in cabinet)</i>	266 kg (585 lb)

Specifications (continued)**Software Prerequisites**

VMS	V5.1 and Higher
ULTRIX	V3.1 and Higher

Hardware Prerequisites

HSC40/50/70	V3.9 and Higher
KDA50	
KDB50	
SDI cables	

DSA Features

SDI ports	2
-----------	---

Digital believes the information in this publication is accurate as of its publication date; such information is subject to change without notice. Digital is not responsible for any inadvertent errors.

The following are trademarks of Digital Equipment Corporation: ALL-IN-1, DBMS, DSA, ESE20, HSC, KDA, KDB, SDI, System Performance Monitor, ULTRIX, VAX, VAX Performance Advisor, VAXcluster System, VAXsimPLUS, VMS, and VMS MONITOR.

Third-party trademarks: PATRAN is a registered trademark of the PDA Engineering Corporation.

Gaussian 82 is distributed by Gaussian, Inc.