

Digital Clusters for Windows NT

Providing the confidence to bring mission-critical applications to your client/server LANs.

With Digital Clusters for Windows NT™, you get a low-cost, scalable, high-availability solution that protects your existing computing investments. Digital provides comprehensive worldwide support to get you started and keep your clusters running.

Highlights

- Very high levels of availability using low-cost, industry-standard components
- A comprehensive clustering solution, not just storage availability or parallel batch job facilities
- Scalability that protects computing investments and builds a cluster incrementally on a customer's existing client/server LAN
- Multiple NT™ Servers — either Intel® or Alpha platforms — in the same cluster, supporting multiple client types
- Comprehensive, worldwide service and support

More than a decade ago, Digital Equipment Corporation pioneered VAXclusters, a major high availability and scalability technology that allowed companies throughout the world to bet their business on a distributed environment. Clusters from Digital became the cornerstone of the world's most dependable computing environment, ensuring that applications and data were always available. Growth in the computing environment was incremental, so customers could add systems and components to existing environments and thus avoid capacity-oriented, forced software migrations.

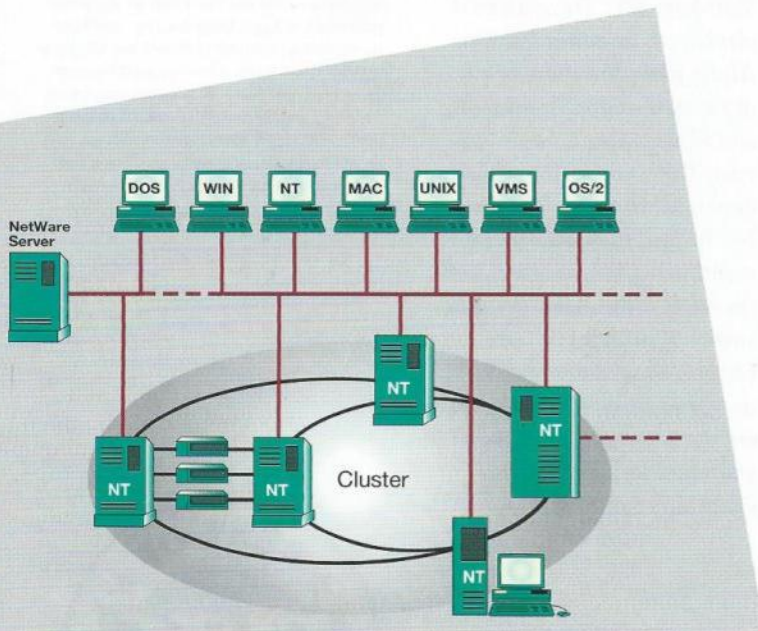

Clusters for Windows NT Technology Demonstration

Viewing a Windows NT Cluster

Clusters are a group of systems accessed and addressed as if they are a single system. You will see how this works and see the advantages of having clusters tightly integrated with Windows NT. You can see how "clustered shares" are accessed through the familiar File Manager utility that you may already know from Windows or Windows NT. You can also see how these shares or directories are accessed without having to know where the directories reside in the cluster. You don't have to learn something new in order to use clusters.

What it shows: Single-system addressability, high degree of integration with Windows NT.

High availability and transparent failover with clusters

You are running an application that is performing reads and writes to files located on a server. Then disaster strikes... the server goes down, but no matter. You don't incur costly downtime, because the service fails over to another server in the cluster, and the application quickly resumes. Digital's cluster technology puts you back to work immediately. And your applications can be familiar office applications you use today, without modification.

What it shows: High-availability, transparent recovery, single-system addressability, ability to utilize clusters with unmodified, out-of-the-box applications.

Today, as more and more customers are implementing mission-critical applications on client/server LANs, the availability and scalability issues are reappearing in the new computing environment. In developing Clusters for Windows NT, Digital is committed to solving these availability and scalability problems in the client/server LAN environment, as we did in the minicomputer environment a decade ago.

At Digital, we have the experience, the expertise, the worldwide service and support, and we have committed our finest technical resources to this vital, new technology. Clusters for Windows NT represents a technology that will allow you to implement your mission-critical, "bet-your-business" applications with confidence on a client/server LAN. With Digital's Clusters for Windows NT, downtime and nonproductive time are reduced to a minimum. And as your business and business needs grow, your LAN servers can grow incrementally, no longer with expensive replacements of existing equipment and software but with incremental, cost-effective additions of systems and components.

What is a cluster, and how can it help my business problems?

A cluster is a group of systems that is addressed and managed as a single system but provides high levels of availability through redundant CPUs, storage, and data paths. Clusters are also highly scalable, meaning that CPU, I/O, and storage can be added incrementally to grow capacity efficiently. A cluster differs from a fault-tolerant system, in that all the components of a cluster are working at all times; there is no idle standby, used only in the event of an outage.

Clusters for Windows NT provide a client/server arrangement where the goal is that you can use essentially any client you have today. These could be the Windows® family, DOS, Macintosh®, UNIX®, OpenVMS, a NetWare® LAN, and of course Windows NT. The clustered servers can be either Intel or Alpha platforms, or a mixture of the two, and are managed and addressed as a single system. Thus, you will be able to deploy Clusters for Windows NT in your existing environment, using the standard, off-the-shelf commodity systems and components you have today. You will be able to add incrementally to your existing environment as you grow, with your data and applications available at all times.

What is Digital doing now, and what will we be doing tomorrow, with Clusters for Windows NT?

Digital has developed and is featuring a technology demonstration of Clusters for Windows NT that shows several things:

- High availability of cluster systems and components
- Seamless integration of clusters with Windows NT
- Single-system addressability
- Compatibility with existing, out-of-the-box applications

Digital believes the information in this publication is accurate as of its publication date; such information is subject to change without notice. Digital is not responsible for any inadvertent errors.

Digital conducts its business in a manner that conserves the environment and protects the safety and health of its employees, customers, and the community.

Digital, the DIGITAL logo, OpenVMS, VAXcluster, and VMS are trademarks of Digital Equipment Corporation.

Intel is a registered trademark of Intel Corporation. Mac and Macintosh are registered trademarks of Apple Computer, Inc. NetWare is a registered trademark of Novell, Inc. OS/2 is a registered trademark of International Business Machines Corporation. Windows is a registered trademark and NT and Windows NT are trademarks of Microsoft Corporation. UNIX is a registered trademark in the United States and other countries, licensed exclusively through X/Open Company, Ltd.

