

VT50/VT52 Pocket Service Guide

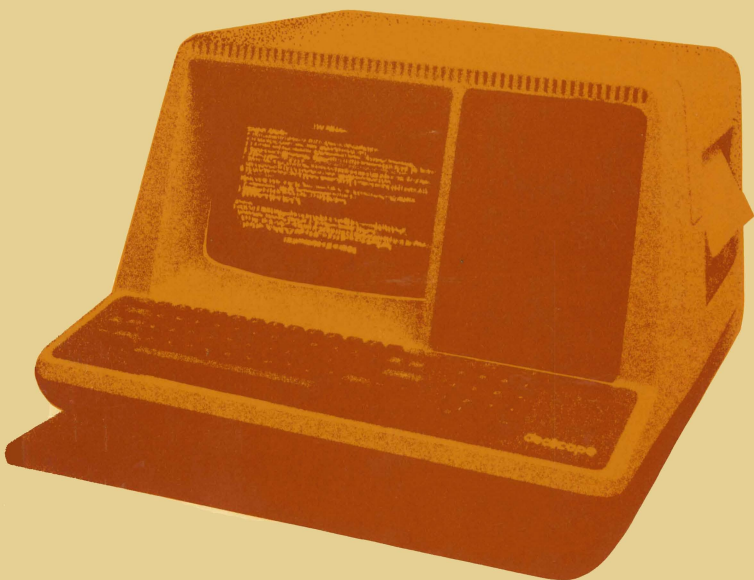

EK-VT502-PG-001

VT50/VT52
Pocket Service Guide

1st Edition, January 1979

Copyright © 1979 by Digital Equipment Corporation

The material in this manual is for informational purposes and is subject to change without notice.

Digital Equipment Corporation assumes no responsibility for any errors which may appear in this manual.

Printed in U.S.A.

The following are trademarks of Digital Equipment Corporation, Maynard, Massachusetts:

DEC	DECtape	PDP
DECCOMM	DECUS	RSTS
DECsystem-10	DIGITAL	TYPESET-8
DECSYSTEM-20	MASSBUS	TYPESET-11
UNIBUS		

CONTENTS

1 INTRODUCTION

1.1 Purpose.....	1
1.2 Reference Documentation.....	1

2 TROUBLESHOOTING

2.1 Troubleshooting Philosophy.....	2
-------------------------------------	---

3 REMOVAL AND REPLACEMENT

3.1 Removing and Replacing the EIA or 20 mA Adapter Card.....	15
3.2 Removing and Replacing the Power Supply/ Monitor Assembly Heat Sink Panel.....	16
3.3 Removing and Replacing the Base Assembly.....	17
3.4 Removing and Replacing the Character Generator.....	18
3.5 Removing and Replacing the Printer Interface Option.....	19
3.6 Removing and Replacing the RUT and DP Modules.....	20
3.7 Removing and Replacing the Anti-Static Ground Shield.....	21
3.8 Removing and Replacing the Keyboard.....	22
3.9 Removing and Replacing the Power Supply/Monitor Assembly.....	23
3.10 Removing and Replacing the CRT Assembly.....	26
3.11 Removing and Replacing the CRT Yoke.....	27
3.12 Removing and Replacing the Electrolytic Copier Option.....	28
3.13 Removing and Replacing the Transformer Assembly.....	29

4 ALIGNMENT AND ADJUSTMENTS

- 4.1 CRT Yoke Alignment
- 4.2 Display Adjustments

5 ACCEPTANCE TEST PROCEDURES

- 5.1 General..... 33
- 5.2 Terminal Tests 33
- 5.3 Copier Option Tests..... 36
- 5.4 Printer Interface Option Tests 36

6 INSTALLATION AND OPERATION

- 6.1 Installation..... 37
- 6.2 Operation..... 37

7 PMK04 OPERATION

APPENDIX A CARE AND HANDLING OF CATHODE RAY TUBES

APPENDIX B REPLACEABLE MODULES AND ASSEMBLIES PARTS LIST

FIGURES

- 2-1 Troubleshooting Procedures Index 3
- 2-2 ROM Chip Locations
- 2-3 Jumper W7 Location.....
- 3-1 Removal and Replacement Guide..... 14
- 3-2 Removing and Replacing the EIA or 20 mA Adapter Card..... 15
- 3-3 Removing and Replacing the Power Supply/Monitor Assembly Heat Sink Panel..... 16
- 3-4 Removing and Replacing the Base Assembly..... 18
- 3-5 Removing and Replacing the Character Generator and Optional Printer Interface Module..... 19
- 3-6 Removing and Replacing the RUT and DP Modules 20
- 3-7 Removing and Replacing the Keyboard 22

3-8	Removing and Replacing the Power Supply/Monitor Assembly	23
9	Discharging the CRT and Power Supply Capacitors	24
3-10	Power Supply/Monitor Assembly Capacitor Connections	25
3-11	Installing the Power Supply/Monitor Board Assembly	26
3-12	Removing and Replacing the CRT Assembly.....	27
3-13	Removing and Replacing the Electrolytic Copier Option	28
3-14	Copier Power and Signal Connectors.....	29
3-15	Transformer Assembly Wiring Diagram	30
4-1	Yoke Alignment	31
4-2	Display Adjustments	32
6-1	Function and Baud Rate Switch Settings.....	38
6-2	Power ON/OFF Switch and Intensity Control Locations	38
B-1	VT52 Replaceable Modules and Assemblies/Parts List	46
C-1	Physical/Functional Block Diagram.....	47

TABLES

2-1	Power on Troubleshooting Procedure.....	4
2-2	Character Display Troubleshooting Procedure.....	7
2-3	Display Troubleshooting Procedure	9
2-4	Copier Option Troubleshooting Procedure	11
2-5	Printer Interface Option Troubleshooting Procedure.....	12
2-6	Printer Interface Option Baud Rate Selection.....	13
7-2	7-Bit ASCII Code	40

1 INTRODUCTION

1.1 PURPOSE

The purpose of this Pocket Service Guide is to provide Field Service engineers and technicians with a convenient source of “memory jogger” reference information for the VT50 and VT52 terminals. This information supplements detailed operation and maintenance information contained in the reference documentation listed in Paragraph 1.2.

1.2 REFERENCE DOCUMENTATION

Document	Document No.
VT52 DECscope Maintenance Manual	EK-VT52-MM-001
DECscope User's Manual	EK-VT5X-OP-001
PMK04 Operating and Service Manual	EK-PMK04-05-001

2 TROUBLESHOOTING

2.1 TROUBLESHOOTING PHILOSOPHY

NOTE

Before attempting to troubleshoot the terminal ensure that there actually is a malfunction by checking that the unit is properly set up for operation with a host computer (Chapter 6).

Figure 2-1 is an index to the troubleshooting procedures contained in Tables 2-1 through 2-5. Step-by-step turn-on and operating instructions are followed by normal display indications. If these indications are absent or incorrect, refer to the corresponding tables for troubleshooting information.

Possible equipment malfunctions are categorized by abnormal symptoms. Corresponding causes are listed in order of probability. Corrective actions are limited mainly to the adjustments and/or substitutions of major replaceable subassemblies suspected to be defective.

If after performing the off-line tests described in this chapter the terminal functions properly but still does not operate correctly when connected to a host computer, verify that portion of the terminal not checked by off-line tests and the interface cabling with the PMK04 tester (Chapter 6).

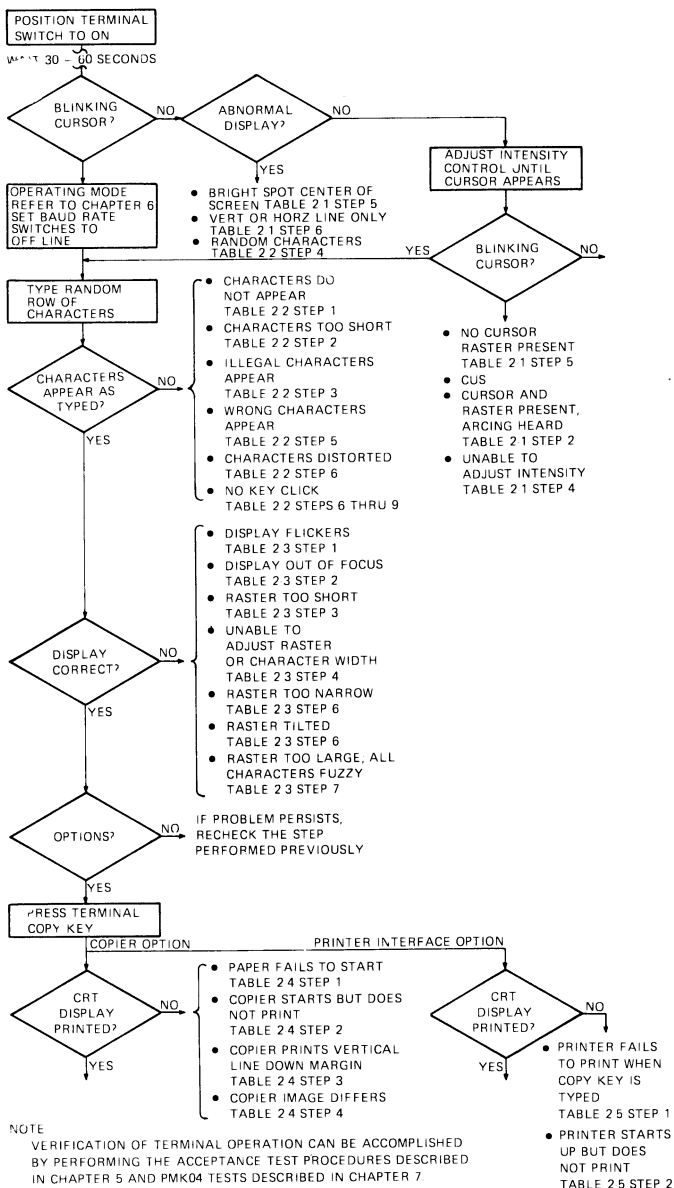

NOTE
 VERIFICATION OF TERMINAL OPERATION CAN BE ACCOMPLISHED BY PERFORMING THE ACCEPTANCE TEST PROCEDURES DESCRIBED IN CHAPTER 5 AND PMK04 TESTS DESCRIBED IN CHAPTER 7.

Figure 2-1 Troubleshooting Procedures Index

4 TROUBLESHOOTING

Table 2-1 Power On Troubleshooting Procedure

Symptom	Possible Cause	Corrective Action
1. No cursor	Unit not plugged into power source	Plug unit into appropriate source of prime power.
	Intensity control turned down	Adjust intensity control (Paragraph 6.2).
2. No cursor; no raster	Blown fuse or tripped circuit breaker	Replace fuse or reset circuit breaker.
	No prime power at power receptacle	Restore source of prime power.

WARNING

There are high voltages present in the power supply and CRT. Ensure that the terminal power line is unplugged and the CRT and capacitors are discharged (Figure 3-9) before handling the power supply or CRT components. Ensure that ground connection is made before discharging these points.

Defective power supply/monitor assembly	Replace power supply/monitor assembly (Paragraph 3.9).
Defective high voltage diode assembly	Replace high voltage diode assembly (Figure 3-8).
Anode cap disconnected	Connect anode cap at power supply (Paragraph 3.2 and Figure 3-8).
Anode clip disconnected	Connect anode clip at CRT bell (Paragraph 3.6 and Figure 3-12).
Defective ON/OFF switch	Replace transformer assembly (Paragraph 3.13).

Table 2-1 Power On Troubleshooting Procedure (Cont)

Symptom	Possible Cause	Corrective Action
	Defective RUT module	Replace RUT module (Paragraph 3.6).
	Defective DP module	Replace DP module (Paragraph 3.6).
WARNING		
Use caution when handling the CRT to avoid shattering the tube. The CRT is a vacuum device which can implode when broken. Refer to Appendix A for care and handling of CRTs before proceeding further.		
	Defective CRT	Replace CRT (Paragraph 3.18).
	Defective circuit breaker	Replace transformer assembly (Paragraph 3.13).
	Defective line filter	Replace transformer (Paragraph 3.13).
	Defective power transformer	Replace transformer assembly (Paragraph 3.13).
	Loose connector	Reseat connectors.
3. No cursor; no raster	Defective keyboard connector	Replace keyboard (Paragraph 3.8).
	Defective keyboard	Replace keyboard (Paragraph 3.8).
	Loose ROMs on RUT module	Reseat ROMs in sockets.
	Defective RUT module	Replace RUT module (Paragraph 3.6).
	Defective DP module	Replace DP module (Paragraph 3.6).

6 TROUBLESHOOTING

Table 2-1 Power On Troubleshooting Procedure (Cont)

Symptom	Possible Cause	Corrective Action
4. Unable to adjust CRT intensity	Defective power supply/monitor board	Replace power supply/monitor board (Paragraph 3.9).
	Defective CRT	Replace CRT (Paragraph 3.18).
5. Bright dot in center of screen	Defective power supply/monitor board	Replace power supply/monitor board (Paragraph 3.9).
	Defective yoke	Replace yoke (Paragraph 3.11).
CAUTION Minimize the time the bright spot is allowed to remain on the CRT to prevent damage to the screen's phosphorescent coating.		
6. Horizontal or vertical line only displayed	Defective power supply/monitor board	Replace power supply/monitor board (Paragraph 3.9).
	Defective yoke	Replace yoke (Paragraph 3.11).
7. Cursor and raster present; arcing heard	Anode cap loose	Replace high voltage diode assembly (Figure 3-8).
	Anode clip loose	Replace high voltage diode assembly (Figure 3-8).

Table 2-2 Character Display Troubleshooting Procedure

Symptom	Possible Cause	Corrective Action
1. Cursor and raster present; cannot display characters	Baud rate or function switch set incorrectly	Set switches to off-line position (Chapter 6).
	Character generator card loose	Reinsert character generator (Paragraph 3.4).
	Defective character generator	Replace character generator (Paragraph 3.4).
	Loose ROMs	Reseat ROMs in sockets.
	Defective RUT module	Replace RUT module (Paragraph 3.6).
	Defective DP module	Replace DP module (Paragraph 3.6).
	Defective keyboard	Replace keyboard (Paragraph 3.8).
2. Characters too short	Vertical size out of adjustment	Adjust vertical size control (Paragraph 4.2.1).
	Vertical linearity out of adjustment	Adjust vertical linearity control (Paragraph 4.2.3).
	Defective power supply/monitor board	Replace power supply/monitor board (Paragraph 3.9).
3. Illegal characters generated	Defective character generator card	Replace character generator card (Paragraph 3.4).
	Defective RUT module	Replace RUT module (Paragraph 3.6).

8 TROUBLESHOOTING

Table 2-2 Character Display Troubleshooting Procedure (Cont)

Symptom	Possible Cause	Corrective Action
4. Random characters fill screen when first turned on	RUT/character ROM/PROM chips are incompatible	Ensure that ROM/PROM chip is A23002B4 series (Figure 2-2).
	Defective character generator card	Replace character generator card (Paragraph 3.4).
	Defective DP module	Replace DP module (Paragraph 3.6).
	Defective RUT module	Replace RUT module (Paragraph 3.6).
5. Wrong character displayed when typed	Defective keyboard	Replace keyboard (Paragraph 3.8).
6. No key clicks; characters legal but distorted	Defective character generator card	Replace character generator card (Paragraph 3.4).
7. No key clicks; cursor present	Defective RUT module	Replace defective RUT module (Paragraph 3.6).
8. No key clicks or cursor; raster present	Defective DP module	Replace defective DP module (Paragraph 3.6).
	Defective keyboard	Replace defective keyboard (Paragraph 3.8).
9. No key clicks; characters	Defective RUT module	Replace defective RUT module (Paragraph 3.6).
	Defective interface card	Replace defective interface card (Paragraph 3.5).

Table 2-3 Display Troubleshooting Procedure

Symptom	Possible Cause	Corrective Action
1. Display flickers	W7 jumper on RUT module	Remove W7 jumper on 60 Hz units or insert W7 jumper on 50 Hz units (Figure 2-3).
2. Display out of focus	Yoke misadjusted	Adjust yoke (Paragraph 4.1).
	Defective power supply/monitor board	Replace power supply/monitor board (Paragraph 3.9).
	Defective CRT	Replace CRT (Paragraph 3.18).
3. Entire raster too short	Vertical size/linearity out of adjustment	Adjust vertical size/linearity control (Paragraphs 4.2.1 or 4.2.3).
4. Unable to adjust raster or character width	Defective power supply/monitor board	Replace power supply/monitor board (Paragraph 3.9).
5. Entire raster too narrow	Horizontal size out of adjustment	Adjust vertical size (Paragraph 4.2.1).
6. Entire raster tilted	Incorrect yoke position	Adjust yoke (Paragraph 4.1).
7. Raster too large; all characters enlarged and fuzzy	Incorrect yoke position	Adjust yoke (Paragraph 4.1).

10 TROUBLESHOOTING

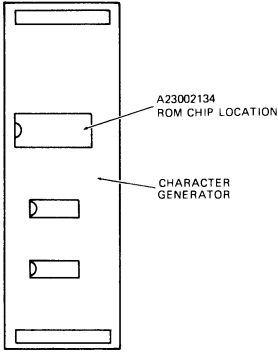

MA 0270

Figure 2-2 ROM Chip Locations

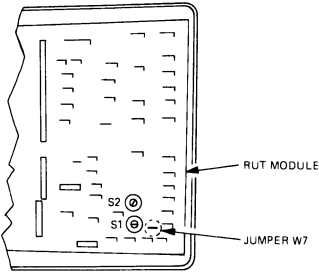

MA 0270

Figure 2-3 Jumper W7 Location

Table 2-4 Copier Option Troubleshooting Procedure

Symptom	Possible Cause	Corrective Action
1. Copier fails to start when COPY key is typed	Paper empty	Install paper.
	Defective copier	Replace copier (Paragraph 3.12).
	Defective DP module	Replace defective DP module (Paragraph 3.6).
	Defective RUT module	Replace defective RUT module (Paragraph 3.6).
	Defective keyboard	Replace defective keyboard (Paragraph 3.8).
2. Copier starts but does not print	Defective power transformer	Replace defective transformer (Paragraph 3.14).
	Dry paper	Check paper moisture content. Replace paper and dampen wick if necessary.
	Copier fuse blown	Replace fuse (one half amp) on copier logic board.
	Defective copier	Replace copier (Paragraph 3.12).
	Defective DP module	Replace defective DP module (Paragraph 3.6).
3. Copier prints vertical line along margin	Defective RUT module	Replace defective RUT (Paragraph 3.6).
	Dry paper	Dampen felt wick. Clean helix wire. Replace paper.
4. Copier image differs from screen image	Defective copier	Replace copier.

12 TROUBLESHOOTING

Table 2-5 Printer Interface Option Troubleshooting Procedure

Symptom	Possible Cause	Corrective Action
1. Printer fails to print when COPY key is typed	Out of paper	Replace paper supply.
	Defective printer	Troubleshoot printer as directed in applicable printer maintenance manual.
	Defective printer interface card	Replace printer interface card (Paragraph 3.5).
	Defective DP module	Replace defective DP module (Paragraph 3.6).
	Defective RUT module	Replace defective RUT module (Paragraph 3.6).
2. Printer starts but does not print	Defective keyboard	Replace defective keyboard (Paragraph 3.8).
	Printer interface baud rate switches set incorrectly	Set printer interface card baud rate switch to correspond to printer requirements. Refer to Table 2-6 for switch settings and corresponding baud rates.
	Defective printer	Troubleshoot printer as described in applicable printer maintenance manual.

Table 2-6 Printer Interface Option Baud Rate Selection

Position	Function/Baud Rate
A	Parallel
B	Serial - 150 Baud
C	Serial - 300 Baud
D	Serial - 600 Baud
E	Serial - 1200 Baud
F	Serial - 2400 Baud
G	Serial - 4800 Baud
H	Serial - 9600 Baud

3 REMOVAL AND REPLACEMENT

This chapter describes the removal and replacement of VT50/VT52 terminal assemblies, modules, and field replaceable components. Figure 3-1 shows the order in which each terminal unit must be removed and provides a convenient reference to the applicable paragraphs.

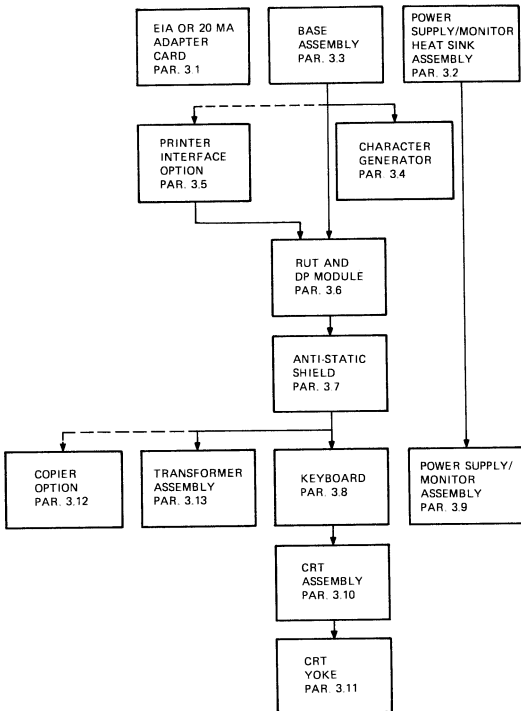

MA 2800

Figure 3-1 Removal and Replacement Guide

WARNING

Before attempting to remove or replace any of the VT50/VT52 assemblies ensure that the power plug is disconnected from the power receptacle and the interface cable is disconnected from the host processor.

3.1 REMOVING AND REPLACING THE EIA OR 20 mA ADAPTER CARD (Figure 3-2)

VT50 terminals are not equipped with a 20 mA adapter card. The interface cable is connected directly to a terminal strip on the RUT module.

NOTE

If the terminal base assembly has a small screened cover, perform the following procedure to remove the EIA or 20 mA adapter card. If the screened cover is permanently attached to the base assembly the entire base must be removed (Paragraph 3.3) before the EIA or 20 mA adapter card can be removed.

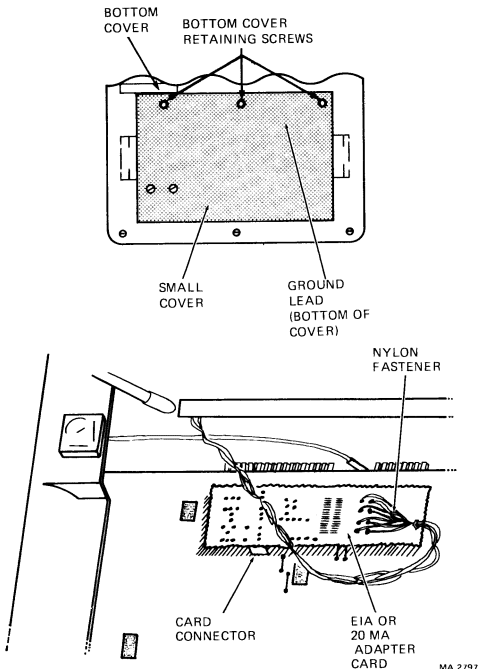

Figure 3-2 Removing and Replacing the EIA or 20 mA Adapter Card

16 REMOVAL AND REPLACEMENT

1. Turn the terminal upside down.
2. Remove the three 1/4 inch machine screws securing the small screened cover to the base assembly and remove the cover.
3. Remove any ground leads or cable restraining leads which may be attached to the cover.
4. Remove the two 1/4 inch self-tapping screws securing the EIA or 20 mA adapter card cable clamp and remove the clamp.
5. Press the tab on the nylon fastener securing the EIA or 20 mA adapter card to the DP module and lift the card free from the connector.
6. Reverse steps 1 through 5 to replace the EIA or 20 mA adapter card.

3.2 REMOVING AND REPLACING THE POWER SUPPLY/MONITOR ASSEMBLY HEAT SINK PANEL (Figure 3-3)

NOTE

If the terminal is the latest VT52 configuration remove the EIA or 20 mA adapter card as described in Paragraph 3.1. If the VT52 is an older configuration the base assembly must be removed in order to remove and replace the EIA or 20 mA adapter card.

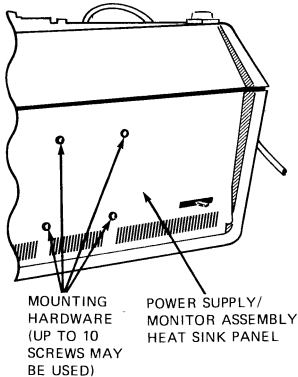

MA 2801

Figure 3-3 Removing and Replacing the Power Supply/Monitor Assembly Heat Sink Panel

1. Turn the terminal right side up.
2. Remove the 1/4 inch machine screws that secure the power supply/monitor assembly heat sink panel to the terminal case. The type and number of screws securing the panel will vary (from 4 to 10) depending on the terminal configuration.
3. If the terminal is equipped with anti-static ground straps that connect the power supply/monitor assembly heat sink panel to the terminal base, remove the three 3/8 inch nuts securing the straps and remove the ground straps.
4. Remove any other ground (green) leads attached to the panel.
5. Reverse steps 1 through 4 to replace the power supply/monitor assembly heat sink panel.

3.3 REMOVING AND REPLACING THE BASE ASSEMBLY (Figure 3-4)

1. If the terminal is equipped with ground straps remove the power supply/monitor assembly heat sink panel (Paragraph 3.2).
2. Turn the terminal upside down.
3. Using a slotted T-wrench (or 1/4 inch nut driver if a T-wrench is not available) turn the base locking screws counterclockwise until they are aligned with the slots in the terminal case.
4. If the terminal has a line cord clamp remove the two 1/4 inch self-tapping screws that secure the clamp; then remove the clamp.
5. Remove the EIA or 20 ma adapter card interface cable clamp (or cable clamp retaining screw depending on the terminal configuration) that secures the cable to the base.
6. Slowly lift the base assembly feeding the line cord and EIA or 20 mA adapter card interface cable through the slots in the base to keep the cords from binding.
7. If the terminal is equipped with anti-static ground straps, remove the 3/8 inch nut that secures the ground strap furthest from the power supply/monitor assembly to the terminal case and remove the ground strap. Be certain to replace and secure the nut as soon as the ground strap is removed.

18 REMOVAL AND REPLACEMENT

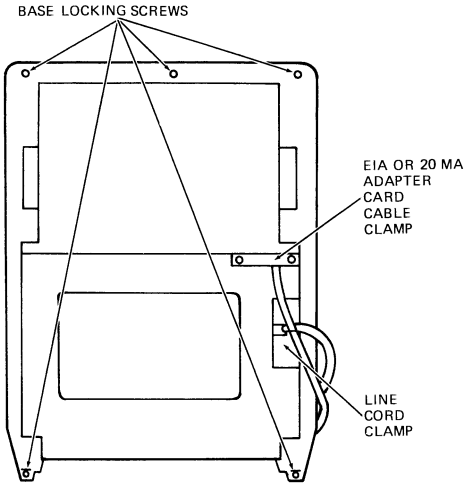

MA 2803

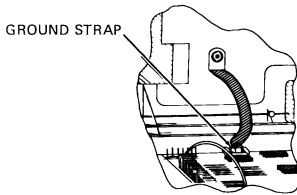

MA 2804

Figure 3-4 Removing and Replacing the Base Assembly

8. Set the base assembly aside.
9. Reverse steps 1 through 8 to replace the base and power supply/monitor heat sink assembly. Remove any excess line cord or interface cabling inside the terminal before securing the base.

3.4 REMOVING AND REPLACING THE CHARACTER GENERATOR (Figure 3-5)

VT50 terminals are not equipped with a character generator card.

1. Remove the base assembly (Paragraph 3.3).

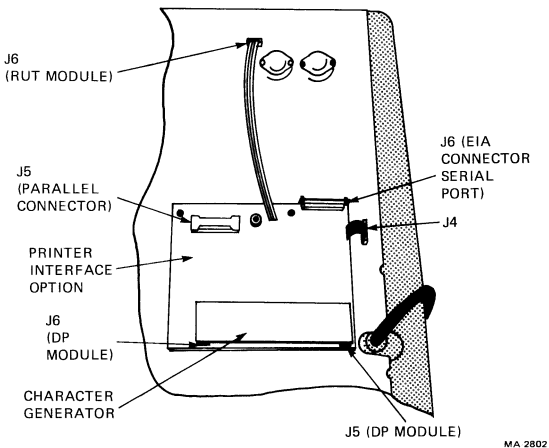

Figure 3-5 Removing and Replacing the Character Generator and Optional Printer Interface Module

2. Disconnect the character generator from the DP module (or printer interface option if applicable).
3. Reverse steps 1 and 2 to replace the character generator. Ensure that the arrow (rear) on the character generator is pointing to the rear of the terminal case.

3.5 REMOVING AND REPLACING THE PRINTER INTERFACE OPTION (FIGURE 3-5)

1. Remove the base assembly (Paragraph 3.3).
2. Remove the character generator (Paragraph 3.4).
3. Remove the EIA or parallel printer interface cable from J5 or J6 on the printer interface card.
4. Disconnect both printer interface cables P1 and P2 from J5 and J6 on the DP module.
5. Remove the two 5/16 inch machine screws that secure the printer interface module to the DP module standoffs.
6. Unplug the printer interface module from the DP module.

20 REMOVAL AND REPLACEMENT

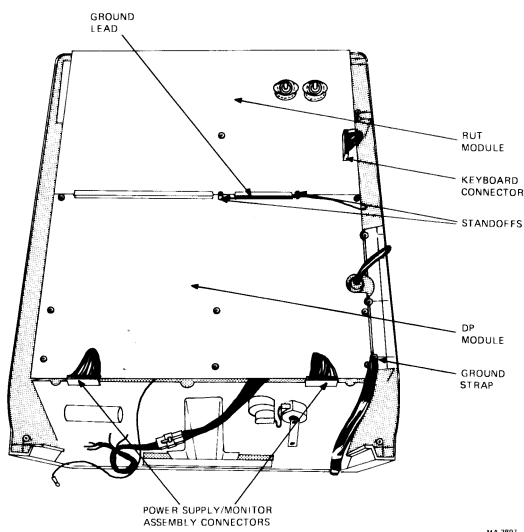

Figure 3-6 Removing and Replacing the RUT and DP Modules

NOTE

Ensure that the interface mode switch is set properly (serial or parallel depending on the type of output required by the printer) and the baud rate switches are set to match the printer baud rate before installing the printer interface card.

7. Reverse steps 1 through 6 to replace the printer interface module.

3.6 REMOVING AND REPLACING THE RUT AND DP MODULES (Figure 3-6)

NOTE

The RUT and DP modules cannot be removed from the terminal separately. Both modules must be removed as a single unit.

1. Remove the base assembly (Paragraph 3.3).
2. Disconnect any ground (green) leads which may be connected to the RUT or DP modules.
3. Disconnect the keyboard and power supply/monitor assembly connectors.

4. If the terminal is equipped with anti-static ground straps, remove the 11/32 nut that secures the ground strap nearest the power supply/monitor assembly (Figure 3-6) and remove the ground strap. *Replace this nut before proceeding to the next step.*
5. Remove the standoffs and hardware (8-32 nuts, wing nuts, or 1/4 self-tapping screws depending on terminal configuration) that secure the RUT and DP modules to the terminal case.

NOTE

The RUT and DP modules are fitted snugly and some pressure might be required to free them. If the modules resist do not exert excessive pressure until you ensure that all hardware securing the modules to the terminal case has been removed.

6. If the terminal has power supply/monitor board assembly support brackets securing the top of the assembly to the terminal cover, remove them.
7. Carefully lift the DP and RUT modules free from the terminal.
8. Separate the RUT and DP modules by grasping both boards firmly and applying outward pressure, first to one side and then the other, to work the boards free.

CAUTION

When replacing the RUT and DP modules align the connector pins exactly. Misalignment of these pins can cause serious damage to the terminal when powered up.

9. Reverse steps 1 through 8 to replace the RUT and DP modules in the terminal.

3.7 REMOVING AND REPLACING THE ANTI-STATIC GROUND SHIELD

1. Remove the base assembly (Paragraph 3.3).
2. Remove the RUT and DP modules (Paragraph 3.6).
3. Remove the nylon washers from the shield. Note that the large nylon washers are on the terminal standoff mounting studs.
4. Lift the shield free from the terminal case.

NOTE

When replacing the anti-static shield ensure that all of the nylon washers are replaced with the larger washers under the two standoffs.

5. Reverse steps 1 through 4 to replace the ground shield in the terminal. Ensure that the holes in the shield are aligned with the RUT and DP module mounting hardware and that all ground leads are accessible after the shield is in place.

3.8 REMOVING AND REPLACING THE KEYBOARD (Figure 3-7)

1. Remove the base assembly (Paragraph 3.3).
2. Remove the RUT and DP modules (Paragraph 3.6).
3. Remove the anti-static ground shield if applicable (Paragraph 3.7).
4. Remove all 1/4 inch self-tapping screws that secure the keyboard assembly to the terminal case.
5. Lift the keyboard free from the terminal.

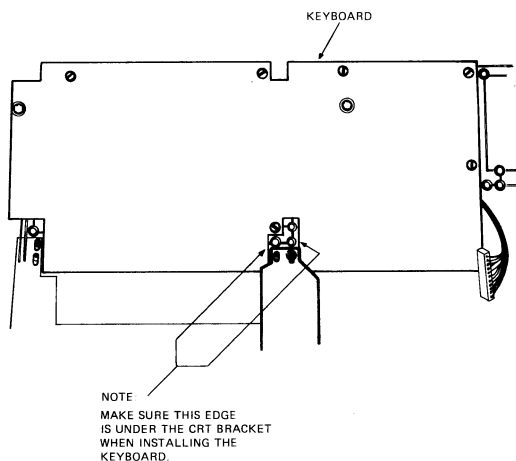

Figure 3-7 Removing and Replacing the Keyboard

CAUTION

Ensure that the keyboard assembly is under the CRT bracket before inserting the mounting hardware. Do not overtighten the mounting hardware; this could crack the board.

- Reverse steps 1 through 5 to replace the keyboard in the terminal. Ensure that the large washers with the insulators under them are replaced in their original position to prevent shorting out the etch.

3.9 REMOVING AND REPLACING THE POWER SUPPLY/MONITOR ASSEMBLY (Figure 3-8)

- Remove the base assembly (Paragraph 3.3).
- Remove the power supply/monitor heat sink assembly (Paragraph 3.2).
- Remove the RUT and DP modules (Paragraph 3.6).
- Remove the anti-static ground shield (Paragraph 3.7).

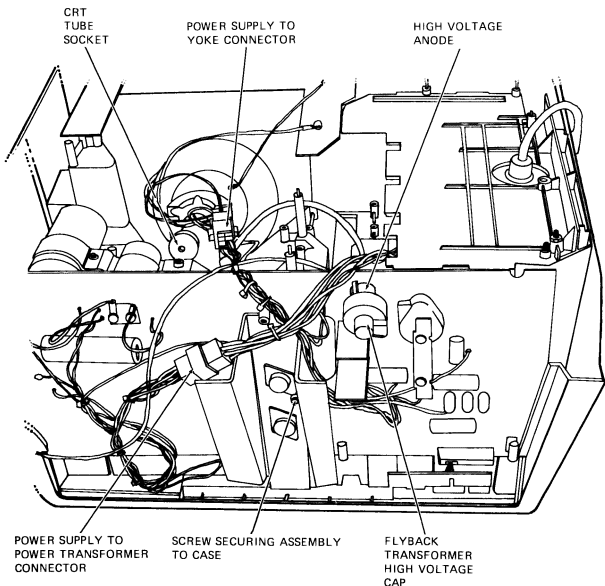

MA 2205

Figure 3-8 Removing and Replacing the Power Supply/Monitor Assembly

WARNING

When performing step 5 do not touch anything on the power supply/monitor assembly but the flyback transformer high voltage cap.

5. Remove the flyback transformer high voltage cap from the CRT high voltage anode.

WARNING

Ensure that the terminal is unplugged before shorting components to the ground. Before proceeding connect a ground wire between any external ground high voltage anode and the capacitor terminals (Figure 3-9) to discharge the CRT and capacitors.

6. Press the tabs on the high voltage anode and push the anode through the assembly to free it.
7. Disconnect the connectors that lead from the power supply/monitor assembly to the transformer assembly.

There are no connectors leading from the power supply to the transformer on some VT50 terminals. Wiring is soldered directly to the power supply monitor assembly.

8. Disconnect the connector that leads from the power assembly to the yoke and tube socket.

There are no connectors between the power supply/monitor and the yoke on some VT50 terminals. Wiring from the yoke is soldered directly to the power supply/monitor assembly.

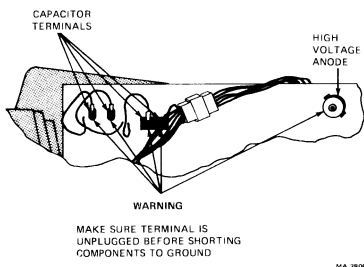

Figure 3-9 Discharging the CRT and Power Supply Capacitors

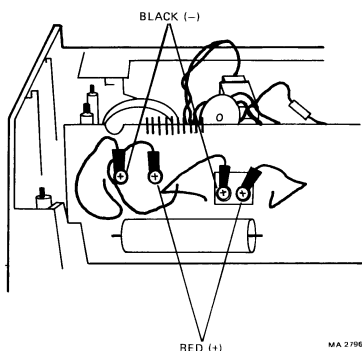

Figure 3-10 Power Supply/Monitor Assembly Capacitor Connections

9. Remove the CRT tube socket.
10. Remove the 1/4 inch self-tapping screw that secures the power supply/monitor assembly to the terminal (Figure 3-8).

On some VT50 terminals the power supply/monitor assembly is secured by four nylon fasteners.

11. Remove the leads from the capacitors (Figure 3-10).
12. Remove the power supply/monitor assembly.
13. Remove the 1/4 inch self-tapping screw that secures the two capacitors to the terminal case and remove the capacitors.

On VT50 terminals the capacitors are secured by nylon straps rather than a metal bracket.

NOTE

When replacing the power supply/monitor assembly ensure that the assembly is properly seated in the terminal (Figure 3-11). When capacitors are installed ensure that terminals extend approximately 1/4 inch beyond the power supply/monitor assembly.

14. Reverse steps 1 through 13 to replace the power supply/monitor assembly.

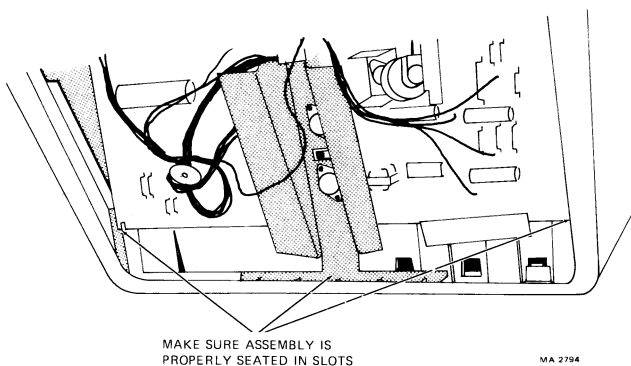

Figure 3-11 Installing the Power Supply/Monitor Board Assembly

3.10 REMOVING AND REPLACING THE CRT ASSEMBLY (Figure 3-12)

1. Remove the base and power supply/monitor heat sink assembly (Paragraph 3.3).
2. Remove the RUT and DP modules (Paragraph 3.6).
3. Remove the anti-static ground shield if applicable (Paragraph 3.7).
4. Remove the keyboard (Paragraph 3.8).
5. Remove the 1/4 inch self-tapping screws that secure the CRT assembly to the terminal case. (The number of screws securing the CRT assembly varies depending on the terminal configuration.)
6. Remove the high voltage lead from the guide if applicable and disconnect the high voltage anode from the power supply/monitor board assembly.
7. Disconnect the CRT tube socket from the power supply/monitor board assembly.
8. Disconnect the yoke from the power supply/monitor board assembly connector.

WARNING

Use extreme care when removing the CRT from the terminal case. Do not carry or support the weight of the tube by its neck. Do not strike or scratch the tube. Avoid placing the tube on a table or bench where it may possibly be knocked off.

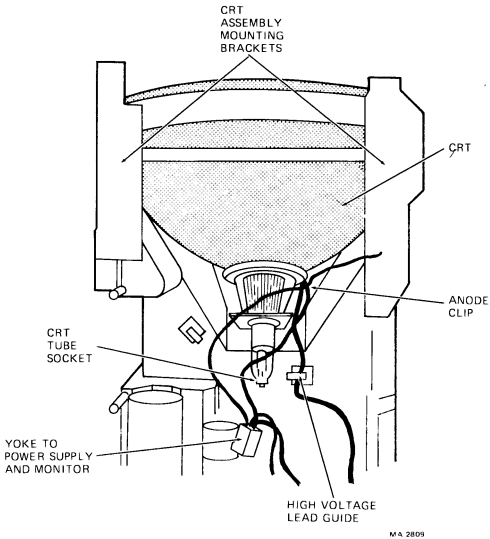

Figure 3-12 Removing and Replacing the CRT Assembly

9. Grasp the CRT mounting brackets and lift the CRT straight up from the terminal case and set it aside.

NOTE

Ensure that cushioning material and the CRT ground straps are in place before replacing the CRT in the terminal.

10. Exercise the same care used to remove the CRT and reverse steps 1 through 9 to replace the CRT in the terminal.

3.11 REMOVING AND REPLACING THE CRT YOKE

1. Remove the base assembly (Paragraph 3.3).
2. Remove the RUT and DP modules (Paragraph 3.6).
3. Remove the anti-static ground shield (Paragraph 3.7).
4. Remove the CRT assembly (Paragraph 3.10).
5. Loosen the screw that secures the yoke assembly to the neck of the CRT. (Do not remove it.)

28 REMOVAL AND REPLACEMENT

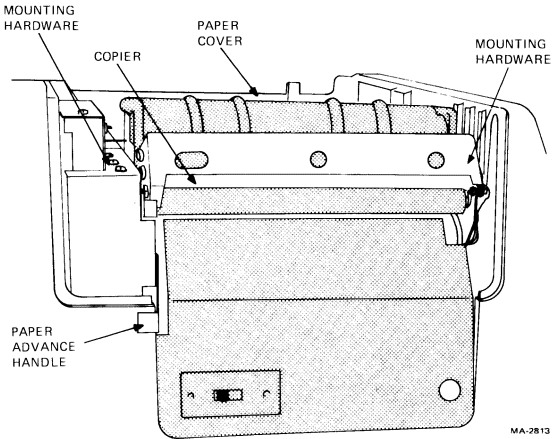

Figure 3-13 Removing and Replacing the Electrolytic Copier Option

WARNING

Use only moderate pressure when removing the yoke from the CRT to avoid breaking the neck of the tube.

6. Slide the yoke from the tube.

NOTE

When replacing the yoke position it as close as possible to its original position.

7. Exercise the same care used to remove the yoke, and reverse steps 1 through 6 to replace the CRT yoke.

3.12 REMOVING AND REPLACING THE ELECTROLYTIC COPIER OPTION

1. Remove the small cover on top of the terminal by pressing the cover tab and lifting the copier cover free.
2. Remove the copier paper cover (Figure 3-13).
3. Remove the five 11/32 inch screws that secure the copier assembly to the terminal case.
4. Remove the copier to the extent necessary to gain access to the copier connectors.
5. Remove the multi-pin copier connector card from the DP module (Figure 3-14).

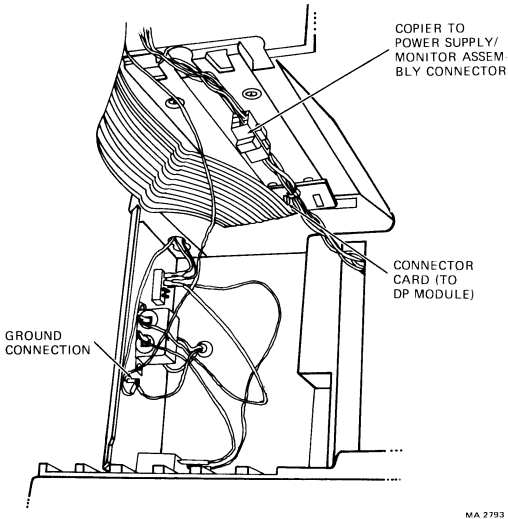

Figure 3-14 Copier Power and Signal Connectors

6. Disconnect the cable that leads to the transformer and remove the copier from the terminal.
7. Remove the 3/8 inch nut that secures the ground lead from the copier to the transformer assembly and remove the ground lead.

NOTE

When installing the copier in the terminal ensure that the paper advance handle on the copier is as shown in Figure 3-13.

8. Reverse steps 1 through 8 to replace the electrolytic copier.

3.13 REMOVING AND REPLACING THE TRANSFORMER ASSEMBLY

1. Remove the base and power supply/monitor heat sink assembly (Paragraph 3.3).
2. Remove the small cover on the top of the terminal by pressing the cover tab and lifting the copier cover free.

30 REMOVAL AND REPLACEMENT

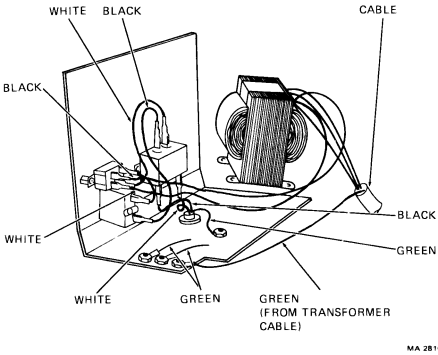

Figure 3-15 Transformer Assembly Wiring Diagram

3. If the terminal is equipped with an electrolytic copier remove the copier (Paragraph 3.12). If the terminal is not equipped with a copier remove the copier well bracket.

Some VT50 terminals may have one large single cover rather than two separate covers.

4. Tip the terminal case on its back.
5. Support the transformer assembly to prevent it from falling when the mounting hardware is removed; then remove the two 11/32 inch nuts that secure the transformer assembly to the terminal case and remove the assembly from the case.

NOTE

Ensure that the edge of the transformer assembly is under the retaining tabs when inserting the assembly into the terminal case.

6. Reverse steps 1 through 5 to replace the transformer assembly. Figure 3-15 shows the interconnecting wiring between the transformer assembly components.

4 ALIGNMENT AND ADJUSTMENTS

4.1 CRT YOKE ALIGNMENT (Figure 4-1)

NOTE

The VT50 has only one large cover which must be removed to gain access to the CRT yoke.

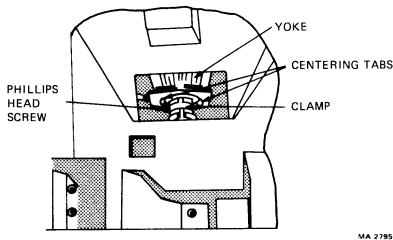
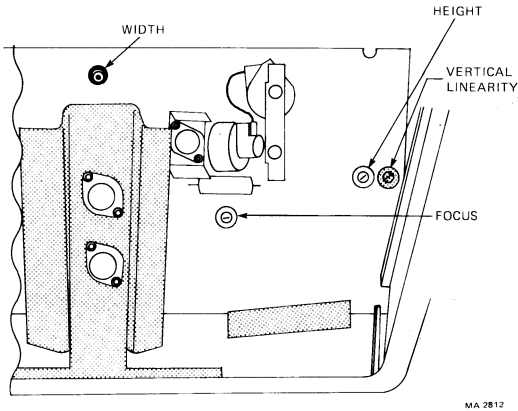

Figure 4-1 Yoke Alignment

1. Remove both covers on top of the terminal.
2. Loosen the Phillips head screw securing the yoke to the neck of the CRT. If the screw is inserted so that the head is not accessible (upside down) remove the RUT and DP modules, and if applicable the ground shield (Paragraphs 3.6 and 3.7). Remove the Phillips head screw and insert it from the opposite direction so that the screw head will be accessible when the terminal is assembled. Reassemble the terminal leaving the top covers off.
3. Set the terminal for local operation as described in Chapter 5 and type a full screen of characters.
4. Rotate the yoke until the display is straight.
5. Tighten the Phillips head screw until the yoke is snug.
6. Adjust the yoke tabs as necessary to center the display.
7. Replace the top covers.



MA 2812

Figure 4-2 Display Adjustments

4.2 DISPLAY ADJUSTMENTS (Figure 4-2)

All display adjustments are located on the power supply/monitor board assembly. Remove the power supply/monitor heat sink assembly (Paragraph 3.2). Set the unit to the off-line mode of operation (Chapter 5) and fill the screen with characters before making any adjustments. Refer to Figure 4-2 for locations of the adjusting coil and potentiometers.

4.2.1 Height

Adjust the vertical size potentiometer to obtain a display height of 4.5 inches (114 mm). This measurement is from the upper edge of the top character line to the lower edge of the bottom character line.

4.2.2 Width

Using a nonconductive hexagonal-tipped alignment tool, adjust the iron slug in coil T3 until the width of the display measures 8.6 inches (218 mm).

4.2.3 Vertical Linearity

Adjust the vertical linearity potentiometer until the characters displayed on the top line are the same size as the characters displayed on the bottom line.

4.2.4 Focus

Adjust the focus potentiometer until characters in all sections of the screen are sharp and clear.

5 ACCEPTANCE TEST PROCEDURES

5.1 GENERAL

Verify that the terminal is operating satisfactorily by performing the following acceptance test procedures.

NOTE

Type the exact character or symbol specified. For example, if the “=” or “o” is to be typed ensure that the CAPS LOCK key (or its equivalent, depending on the terminal configuration) is not locked which would produce a “+” or capital “o”.

5.2 TERMINAL TESTS

5.2.1 Off-Line

1. Set the baud rate switches on the bottom of the terminal for off-line operation (S1 to position 1 and S2 to position G) as described in Chapter 6.
2. Plug the terminal line cord into an appropriate ac power source and turn the terminal on.

NOTE

Allow 30 to 60 seconds for the terminal to warm up. A flashing cursor should then appear on the screen. If it does not appear or if an abnormal display occurs (such as a horizontal line or a bright dot in the center of the screen) refer to Table 2-1.

3. Type a random row of characters. Then adjust the intensity control at the rear of the terminal for the desired CRT brightness. (If the intensity control cannot be adjusted or if the characters do not appear on the screen refer to Tables 2-1 or 2-2.)
4. Press and lock the CAPS LOCK key. (On some terminals this key is referred to as the SHIFT LOCK key; on others it is the blank key above the SHIFT key.)

NOTE

If during performance of the following steps the correct indications cannot be observed on the screen refer to the appropriate troubleshooting table referenced in Figure 2-1.

5. Hold the CTRL key down and type the letter *G*; the buzzer should sound.
6. Type *ESC* and the letter *Z*. Check that the terminal identifies itself with the correct character for each terminal variation:
 - VT52 - *K*
 - VT52 with copier - *L*
 - VT52 with printer - *M*
 - VT50 - *A*
7. Type a few characters on each line.
8. Type a full row of random characters on the last line. *Do not press the RETURN or LINE FEED keys.*
9. Hold the CTRL key down and type the letter *M*; the cursor should move to the extreme left margin.
10. Type *ESC* and the letter *K*; all characters on the bottom line should be erased.
11. Type *ESC* and the letter *H*; the cursor should return to the home position (upper-left corner of the screen).
12. Type *ESC* and the letter *J*; all characters on the screen should be erased.
13. Type *ESC* and the letter *C*; the cursor should move to the right. Continue typing *ESC* and *C* until the cursor is in the center of the screen.
14. Hold the CTRL key down and type the letter *J*; the cursor should move down one line.
15. Type *ESC* and the letter *A*; the cursor should move up one line.
16. Hold the CTRL key down and type the letter *H*; the cursor should move one position to the left.
17. Hold the CTRL key down and type the letter *I*; the cursor should move to the next tab stop.
18. Press LINE FEED several times.

NOTE

Do not perform steps 19 through 23 when performing acceptance tests on VT50 terminals.

19. Type *ESC* and the letter *I*; the cursor should move up one line. This performs a downward scroll if the cursor is on the top line.
20. Type *ESC* and the letter *B*; the cursor should move down one line.
21. Type *ESC* and the letter *D*; the cursor should move left one position.
22. Type *ESC* and the = symbol. The terminal should now be in alternate keypad mode. Numbers typed on the auxiliary keypad should respond with the following characters:

Key	Character Displayed
0	p
1	q
2	r
3	s
4	t
5	u
6	v
7	w
8	x
9	y
enter	M

23. Type *ESC* and the > symbol; the terminal should exit alternate keypad mode. Numbers typed on the keypad should now be displayed as numbers on the CRT.
24. Type LINE FEED until the cursor is on the bottom line.
25. Type *ESC* and the [symbol; the terminal should now be in hold screen mode.
26. Type LINE FEED.
27. Type *VT52*; the characters should *not* appear on the screen.
28. Type *SCROLL*; the characters *VT52* should now appear on the screen.
29. Type *ESC* and the \ symbol; the terminal should now exit hold screen mode.
30. Type LINE FEED; the message should scroll up.
31. Type *ESC* and the letter *H*; the cursor should move to the first character position in the first line.

NOTE

Do not perform steps 32 through 34 if you are verifying the operation of a VT50 terminal.

32. Type *ESC* and the letter *Y*. Type the numeral 7 and the letter *o*; the cursor should move to the last character position on the last line.
33. Type *ESC* and the letter *Y*. Type the numeral 7 and press the space bar; the cursor should move to the first character position on the last line.
34. Type *ESC* and the letter *Y*; press the space bar the type the letter *O*. The cursor should move back to the last character position on the first line.
35. Type *ESC* and the letter *Y* and press the space bar twice; the cursor should move back to the first character position on the first line.

5.2.2 On-Line Tests

If you have access to a PDP-11 or PDP-8 system, connect the terminal to a processor and run the following diagnostics at least once.

PDP-11 - MAINDEC-11-DZVTC-C
PDP-8 - MAINDEC-08-DHVTC-D

5.3 COPIER OPTION TESTS

Set up the terminal for off-line operation (Chapter 7). Type a few lines of random characters and press the COPY key. All information displayed on the screen should be reproduced on the copier.

5.4 PRINTER INTERFACE OPTION TESTS

Verify the printer interface operation in the same manner as the copier (Paragraph 5.3).

6 INSTALLATION AND OPERATION

6.1 INSTALLATION

To install the VT50/VT52 terminal, perform the following procedure:

1. Unpack the terminal and options (printer interface card or electrolytic copier) to be installed in the terminal.
2. Install the option (if applicable) as directed by the installation instructions provided with each option.

NOTE

If the printer interface option is installed in the terminal ensure that the baud rate switch settings on the board correspond to the printer requirements before reassembling the terminal (Table 2-6).

3. Place the terminal on a desk or suitably sized table or workbench near a convenient source of prime power. Prime power requirements are stated on the outside of each terminal.

CAUTION

Do not plug in the line cord yet.

4. Connect the terminal interface cable to the host processor and the printer interface cable, if applicable, to the printer.
5. Tip the terminal up to gain access to the baud rate switches on the bottom of the base assembly.
6. Use a screwdriver or small coin to set S1 to position 1 and S2 to position G. Figure 6-1 shows the functions and baud rates which can be selected with S1 and S2.
7. Plug the line cord into the prime power outlet.

6.2 OPERATION (Figure 6-2)

To operate the VT50/VT52 terminal in off-line mode perform the following:

1. Set the power ON/OFF switch to ON.

38 INSTALLATION AND OPERATION

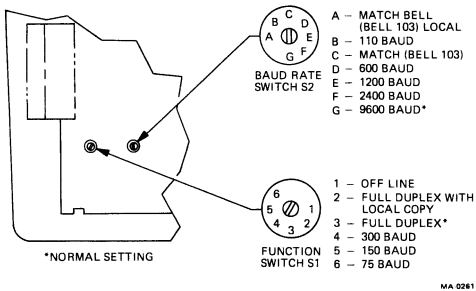

Figure 6-1 Function and Baud Rate Switch Settings

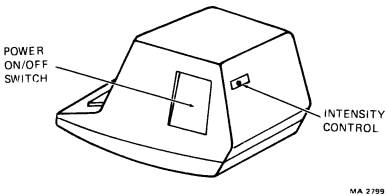

Figure 6-2 Power ON/OFF Switch and Intensity Control Locations

2. After approximately 30 seconds observe that the blinking cursor appears in the upper-left corner of the screen.

NOTE

If the cursor does not appear within one minute after setting the power switch to ON, adjust the intensity control to obtain the cursor. If the cursor still cannot be obtained, refer to the appropriate troubleshooting procedure in Chapter 2.

3. Type a random row of characters and adjust the intensity control to obtain the best character definition and viewing comfort.

The terminal is now operational. To place the unit on-line refer to the *DECscope Users Manual* and to the user documentation supplied with the terminal's host processor.

Ensure that the customer has received a copy of the *DECscope User's Manual* and that he is aware of the importance of reading it thoroughly before operating the terminal.

7 PMK04 OPERATION

To set up and test the VT50/VT52 terminal using the PMK04, perform the following procedure:

1. Set the VT50/VT52 power switch to OFF.
2. Disconnect the terminal interface cable from the host processor.
3. Plug in the PMK04 tester.
4. Set the PMK04 TRANSMIT/RECEIVE baud rate switches (Table 7-1) to match the setting of the terminal baud rate switches. Figure 6-1 shows the baud rate switch settings. Table 7-1 shows the RECEIVE/TRANSMIT switch settings for the PMK04.

Table 7-1 RECEIVE/TRANSMIT Switch Settings

4	2	2	Baud Rate
down	down	down	110
down	down	up	150
down	up	down	300
down	up	up	600
up	down	down	1200
up	down	up	2400
up	up	down	4800
up	up	up	9600

NOTE

The PMK04 has split speed capability. It can transmit data at one baud rate and receive data at another. When using split speed, ensure that the transmit/receive rates of the tester are compatible with the receive/transmit rates of the terminal.

5. Set the PMK04 TRANSMIT switch to OFF.
6. Set the DATA REGISTER switches to select the character to be transmitted to the terminal being tested. Table 7-2 contains a list of the switch positions and corresponding ASCII characters selected. (No switch settings are required if operating the PMK04 in increment mode.)

Table 7-2 7-Bit ASCII Code

Octal Code	Char	Octal Code	Char
000	NUL	040	SP
001	SOH	041	!
002	STX	042	“
003	ETX	043	#
004	EOT	044	\$
005	ENQ	045	%
006	ACK	046	&
007	BEL	047	'
010	BS	050	(
011	HT	051)
012	LF	052	*
013	VT	053	+
014	>FF	054	,
015	CR	055	-
016	SO	056	.
017	SI	057	/
020	DLE	060	0
021	DC1	061	1
022	DC2	062	2
023	DC3	063	3
024	DC4	064	4
025	NAK	065	5
026	SYN	066	6
027	ETB	067	7
030	CAN	070	8
031	EM	071	9
032	SUB	072	:
033	ESC	073	;
034	FS	074	<
035	GS	075	=
036	RS	076	>
037	US	077	?

Table 7-2 7-Bit ASCII Code (Cont)

Octal Code	Char	Octal Code	Char
100	@	140	\
101	A	141	a
102	B	142	b
103	C	143	c
104	D	144	d
105	E	145	e
106	F	146	f
107	G	147	g
110	H	150	h
111	I	151	i
112	J	152	j
113	K	153	k
114	L	154	l
115	M	155	m
116	N	156	n
117	O	157	o
120	P	160	p
121	Q	161	q
122	R	162	r
123	S	163	s
124	T	164	t
125	U	165	u
126	V	166	v
127	W	167	w
130	X	170	x
131	Y	171	y
132	Z	172	z
133	[173	-
134	\	174	
135]	175	}
136	^	176	~
137	-	177	DEL

42 PMK04 OPERATION

7. Set the CHARACTER function switch (INCREMENT/DATA REGISTER) to the desired mode of transmission.

NOTE

When placed in the DATA REGISTER position the characters selected in the DATA REGISTER switches will be transmitted to the terminal respectively (if in continuous mode). When placed in the increment mode, the PMK04 internal logic will transmit the character selected in the data register first and then increment and send the next 7-bit ASCII character. This procedure will continue until stopped by the operator. In either case, each new line will begin with the character selected by the DATA REGISTER switches.

8. Set the COLUMN COUNT switches for the desired column count of the terminal being tested.
9. Set the CHARACTER RATE switch to MAXIMUM or MINIMUM character transmission as desired.

NOTE

When set to MAXIMUM, characters are transmitted continually at the selected baud rate. When set to MINIMUM, characters are transmitted at 10 characters per second regardless of the selected baud rate.

10. Set the character function switch to select the ASCII character to be transmitted (64 or 96).

NOTE

The character set selected on the PMK04 does not have to match the character set of the terminal being exercised.

11. Set the MODE switch to either ECHO or FDX mode.

NOTE

In the ECHO position, any character transmitted from the terminal under test to the PMK04 will be displayed on the RECEIVED/ECHOED CHARACTERS LEDs and then retransmitted to the terminal. In the FDX position, the PMK04 character generation circuits are enabled. Characters are generated and transmitted to the terminal under test and at the same time are displayed on the RECEIVED/ECHOED CHARACTERS LEDs.

12. Set the FILL CHARACTER switch to 0.
13. Set the PARITY switch to ON or OFF and select either EVEN or ODD parity.

NOTE

Setting the parity switch to ON and selecting EVEN or ODD parity causes the tester to transmit the correct parity to the terminal. The tester will also monitor the parity of the received data and illuminate the PARITY ERROR MONITOR indicator if an error is detected.

14. Set the LINE switch to NORM.
15. Set the OUTPUT switch to TERM.
16. Connect the terminal's interface cable to the proper input terminal on the PMK04 front panel.
17. Set the terminal function switch to off-line (Chapter 6).
18. Set the terminal power switch to ON.
19. Set the tester PWR switch to ON.
20. Set the TRANSMIT function switch to either SINGLE or CONTINUOUS to start data transmission.

NOTE

When OFF no character will be transmitted. When set to the CONTINUOUS position a steady stream of characters will be transmitted from either the switch register or the incrementing register at the speed and baud rate selected. When the switch is moved to the spring-loaded SINGLE CHARACTER position, one character is transmitted from either the switch register or the incrementing register at the baud rate selected. Repeated SINGLE CHARACTER operation of this switch will send one character for each switch operation.

APPENDIX A

CARE AND HANDLING OF CATHODE RAY TUBES (CRTS)

When servicing or replacing CRTs or CRT assemblies in VT50 or VT52 terminals observe the following procedures.

Service Areas

CRTs should not be replaced at a customer site unless the site is equipped with a service shop. The CRT assembly can be replaced at the site but *only DEC service personnel should be in the area during CRT replacement.*

Protective Gear

Servicemen replacing a CRT must wear gloves and safety glasses with side guards.

Discharging CRT Voltage

Before servicing a CRT or its associated circuitry, discharge the tube by touching the anode with a wire firmly connected to chassis ground.

Handling Precautions

Observe the following handling precautions at all times.

1. Never handle the CRT by the neck; lift from the sides adjacent to the face.
2. Do not strike the neck of the CRT.
3. Do not rest the tube on its back.
4. Do not allow the tube to become scratched.
5. Never allow a soldering iron to come in contact with the tube.

Storage

Store the tube in a closed shipping container when it is not mounted in the terminal.

Disposal

In lieu of any regional disposal procedure, perform the following:

1. Place the CRT to be scrapped (not to be returned for repair) in the container in which the replacement CRT arrived.
2. Seal the container. Use a hammer to drive a screwdriver, rod, chisel, or similar tool through the cardboard and into the face of the tube.

The safe implosion of the tube prevents liability and safety problems which arise when untrained people handle the tube.

APPENDIX B

REPLACEABLE MODULES AND ASSEMBLIES/PARTS LIST

Figure B-1 shows the interrelationship of the field replaceable modules and lists all corresponding part numbers.

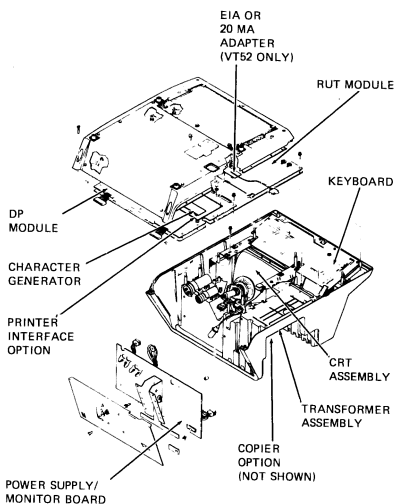

MA 2811

REPLACEABLE MODULES *

MODULE	P/N VT52	VT50
CHARACTER GENERATOR	54-11815-00	54-11815-00
RUT MODULE	54-11743-00	54-1096-01
DP MODULE	54-11745-00	54-1090-01
KEYBOARD	54-11170-00	54-10893-0-1(A) 54-11170-0-1 (HJ)
POWER SUPPLY/ MONITOR ASSY.	54-10886-00	54-10886-01
CRT ASSY.	70-10859-00	70-10859-00
CRT YOKE	70-11187-00	
TRANSFORMER ASSY. (115V)	70-10861-03	70-10861-01
TRANSFORMER ASSY. (220V)	70-10861-04	70-10861-00
PRINTER INTERFACE OPTION		
EIA CARD	BN52A-7F	54-11448-00
20 MA ADAPTER CARD	BN52B-7F	NA
COPIER	70-10068-XX	70-10068-XX

NOTE: NOT ALL DASH VARIATIONS COVERING
TERMINAL DEVIATIONS ARE LISTED.

Figure B-1 VT52 Replaceable Modules and Assemblies/Parts List

APPENDIX C PHYSICAL/FUNCTIONAL BLOCK DIAGRAM

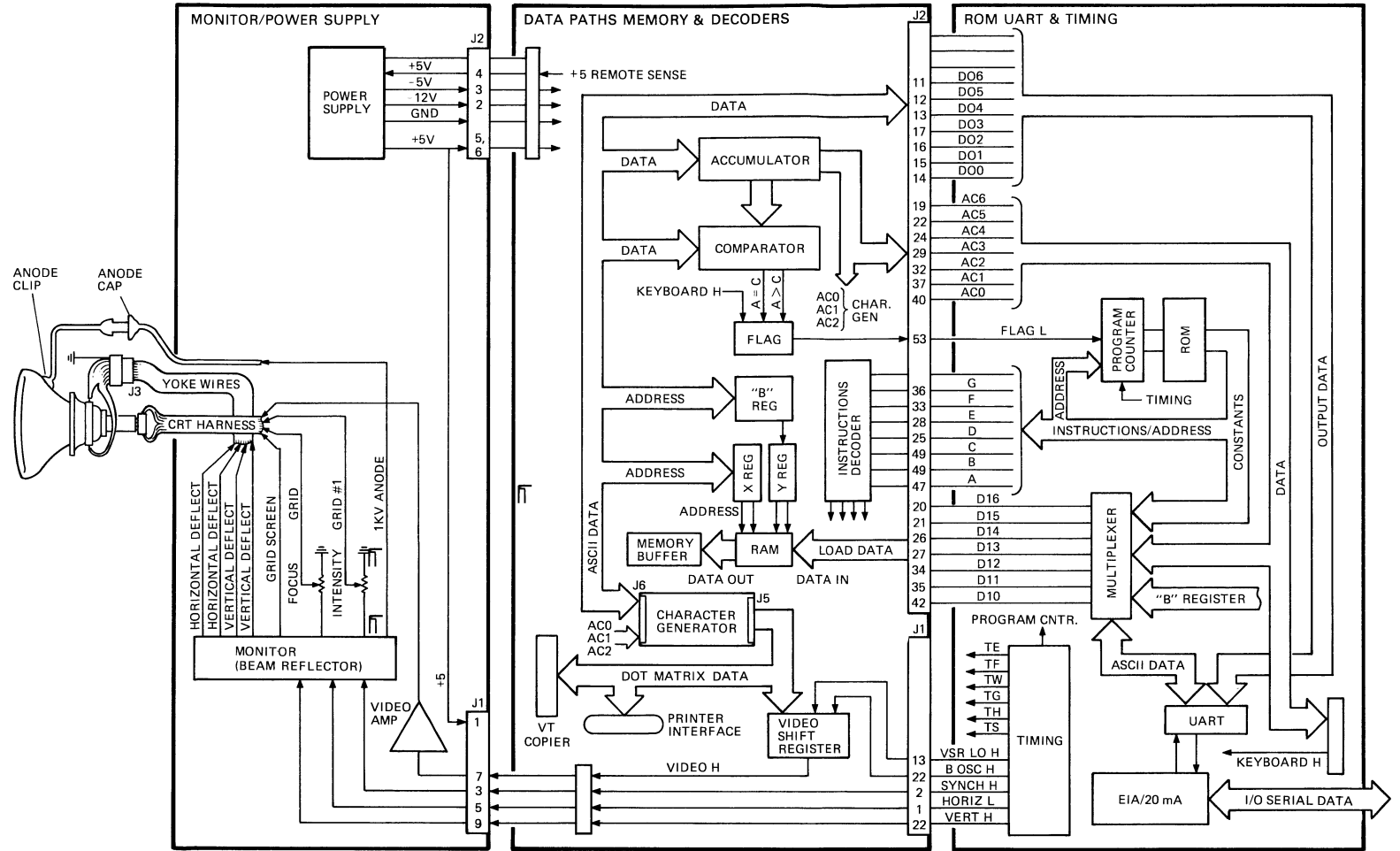

MA-1554

Physical/Functional Block Diagram



EDUCATIONAL SERVICES

digital