

VT340+ Model G Service Guide

Order Number EK-VT34R-SV-001

**digital equipment corporation
maynard, massachusetts**

First Edition, April 1990

The information in this document is subject to change without notice and should not be construed as a commitment by Digital Equipment Corporation. Digital Equipment Corporation assumes no responsibility for any errors that may appear in this document.

The software described in this document is furnished under a license and may be used or copied only in accordance with the terms of such license.

No responsibility is assumed for the use or reliability of software on equipment that is not supplied by Digital Equipment Corporation or its affiliated companies.

Restricted Rights: Use, duplication, or disclosure by the U. S. Government is subject to restrictions as set forth in subparagraph (c) (1) (ii) of the Rights in Technical Data and Computer Software clause at DFARS 252.227-7013.

Copyright © Digital Equipment Corporation 1990

All Rights Reserved.
Printed in U.S.A.

The following are trademarks of Digital Equipment Corporation:

DEC	DIBOL	UNIBUS
DEC/CMS	EduSystem	VAX
DEC/MMS	IAS	VAXcluster
DECnet	MASSBUS	VMS
DECsystem-10	PDP	VT
DECSYSTEM-20	PDT	
DECUS	RSTS	
DECwriter	RSX	

This document was prepared and published by Educational Services Development and Publishing, Digital Equipment Corporation.

Contents

About This Guide

vii

1 Product Description

1.1	Video Monitor Variations	1-1
1.2	Monitor Description	1-3
1.3	Tools and Equipment	1-5
1.4	Recommended Spares List	1-5
1.5	Data Input Devices	1-6

2 Testing and Troubleshooting

2.1	Using Self-Tests	2-1
2.2	Power-Up Self-Test	2-1
2.3	If the Test Finds an Error	2-2
2.4	Diagnostic Set-Up Screen	2-3
2.4.1	Diagnostic Set-Up Screen Format	2-3
2.4.2	How to Change a Current Setting of a Test	2-4
2.4.3	How to Run a Self-Test	2-4
2.5	Diagnostic Self-Tests	2-4
2.5.1	Loopback Tests	2-5
2.5.2	Power-Up Test	2-8
2.5.3	Screen Tests	-8
2.6	Printer Problems	2-8
2.7	Self-Test Error Messages and Codes	2-10
2.7.1	NVR Error—1 Code	2-11
2.8	Troubleshooting General Problems	2-12

3 Removing and Replacing FRUs

3.1	Rear Panel	3-1
3.2	Rear Enclosure/Base Assembly	3-2
3.3	Terminal Control Module	3-5
3.4	Discharging the CRT	3-7
3.5	Video Amp Module	3-10
3.6	Power Supply/Monitor Module and Arc Protection Module ..	3-13
3.6.1	Input Voltage Selection	3-22
3.6.2	Service Switch	3-23
3.7	AC Inlet/Switch Assembly	3-24
3.8	Control/Bracket Assembly (Brightness and Contrast)	3-26
3.9	CRT/Bezel/Chassis Assembly	3-28
3.10	CRT Disposal	3-29
3.11	Keyboard	3-34
3.12	Mouse or Tablet (Options)	3-38

4 Aligning the Video Terminal

4.1	General	4-1
4.2	Video Terminal Adjustments	4-1
4.2.1	Before You Start	4-4
4.2.2	Setting Cutoff	4-5
4.2.3	Radiance Meter	4-9
4.2.4	Displaying Screen Tests	4-11
4.2.5	Color Gain	4-12
4.2.6	Display Size	4-15
4.2.6.1	Horizontal Centering	4-16
4.2.6.2	Horizontal Phase	4-17
4.2.6.3	Rectangularity	4-18
4.2.6.4	Vertical Centering	4-19
4.2.6.5	Horizontal Width and Vertical Height	4-20
4.2.7	Character Quality	4-22
4.2.7.1	Linearity	4-24
4.2.7.2	Focus	4-25
4.2.8	Viewer Preference	4-27

5 Using Set-Up

5.1	What is Set-Up	5-1
5.1.1	Dual Sessions	5-1
5.2	Entering and Leaving Set-Up	5-1
5.3	Selecting A Set-Up Screen	5-2
5.4	Selecting Set-Up Features	5-3
5.5	Saving Set-Up Values	5-3
5.6	Recalling Set-Up Values	5-4

A Related Documentation

B Troubleshooting The Session Support Utility

B.1	Checking Software and Set-Up	B-1
B.2	Problems with Enabling SSU Software	B-2
B.3	DECserver LAT Problems	B-4

C FRU Exploded View Diagrams

D Cables

E Physical/Functional Diagram

Figures

1-1	VT340+ Rear Panel—Model Variations	1-2
1-2	VT340+ Block Diagram	1-4
2-1	Successful Power-Up Self-Test Display	2-2
2-2	Diagnostic Set-Up Screen	2-3
2-3	VT340+ Ports and Loopback Connectors	2-6
4-1	Video Adjustment Controls (1 of 2)	4-2
4-2	Video Adjustment Controls (2 of 2)	4-3
5-1	Set-Up Directory	5-2
C-1	VT340+ FRUs (External View)	C-2
C-2	VT340+ FRUs (Internal View)	C-3

D-1	VT340+ Cable Connections	D-3
E-1	Connection Diagram	E-2

Tables

2-1	VT340+ Display Error Messages	2-10
2-2	VT340+ Troubleshooting Chart	2-12
4-1	Adjustment Controls	4-4
D-1	Interface Cables and Adapters	D-1
E-1	VT340+ Signals and Pin Assignments	E-3

About This Guide

This guide describes how to service your VT340+ model G color video terminal.

Organization

The guide has five chapters and five appendices. They cover the following topics:

- Troubleshooting the field replaceable units (FRUs)
- Removing and replacing FRUs
- Aligning the video monitor
- Using set-up features
- Related documentation
- Troubleshooting the Session Support Utility
- Exploded view and part numbers of unit
- Cables
- Physical/functional diagram

Intended Audience

This guide is for Digital Customer Services Engineers.

Conventions

This document uses the following conventions:

Convention	Meaning
Warning	Provides information to prevent personal injury.
Caution	Provides information to prevent damage to the equipment.
Note	Provides general information.
PN	Part number.

Product Description

This chapter gives a general description of the VT340+ terminal, and also lists the tools and spare parts you may need when servicing the unit.

1.1 Video Monitor Variations

This guide describes VT340+ model G, which is a modified version of the VT340+ model A. The following table identifies the original and modified versions of the VT340+ color video terminal.

Original	Modified	Voltage	Location
VT340-A2	VT340-G2	120 V	Northern Hemisphere
VT340-A3	VT340-G3	240 V	Northern Hemisphere
VT340-A4	VT340-G4	120 V	Southern Hemisphere
VT340-A5	VT340-G5	240 V	Southern Hemisphere

You can identify the model by looking at the label on the rear of the terminal (Figure 1-1).

The new VT340-G differs from the VT340-A in two ways:

- The VT340-G does not use the plug-in ROM cartridge because the operating software is stored on ROM chips. The ROM chips are on the terminal control module.
- The VT340-G contains a simpler logic design with all control and bitmap logic located on one terminal control module.

1-2 Product Description

For information on the VT340-A, refer to the *VT340+ Pocket Service Guide* (EK-VT340-PS-002).

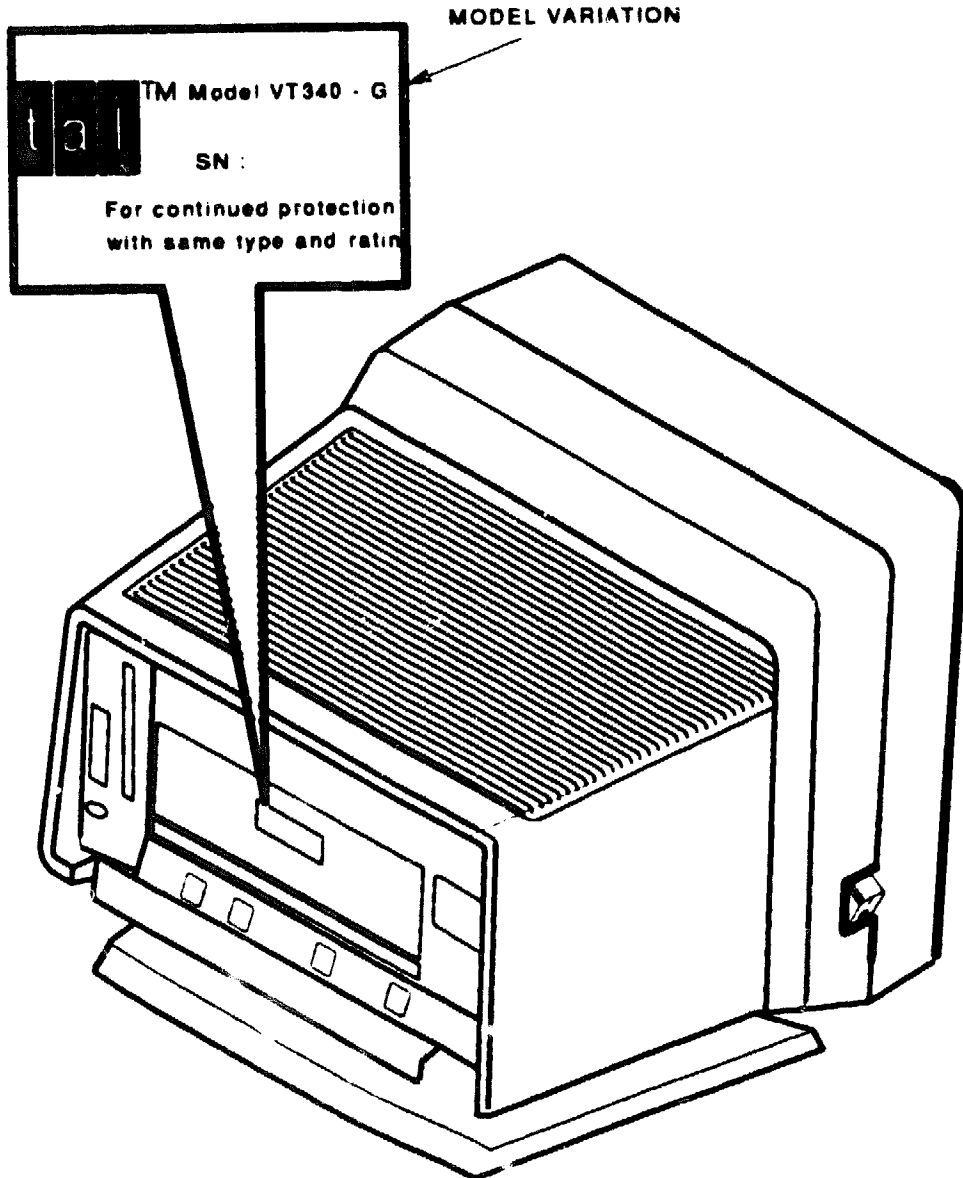

MA-X0000-00

Figure 1-1 VT340+ Rear Panel—Model Variations

1.2 Monitor Description

The VT340+ model G is a text and graphics color video terminal that is compatible with the VT241 terminals. The VT340+ supports different versions of the Digital LK201 corporate keyboard for different languages.

NOTE

Throughout this manual, "VT340+" will be used to describe the VT340+ model G terminal.

The VT340+ uses a four-plane bitmap to display 16 colors at a time, from a palette of 4096 possible colors. The monitor has a 332 mm (13 inch) antiglare flat screen that can display 24 rows of text in 80 or 132 columns. The 25th display line is a status line. The monitor supports multiple sessions. When connected to a host system, the monitor can display information you send to the host system and information the host system sends to you.

The power supply receives AC input and generates five regulated output DC voltages (+5V, +12V, -12V, +72V, +93V). The power supply operates in a flyback switch mode at 31.5 KHz which is synchronized to the horizontal scanning frequency of the terminal.

The AC input can be configured with the help of a voltage select jumper on the power supply board. The jumper allows you to select 110V and 220V (factory setting) as the AC input voltage. The terminal can operate within two voltage ranges: 100 to 120 Vac (88 to 132 Vac), 60 Hz; and 220 to 240 Vac (176 to 264 Vac), 50 Hz. A 4 amp, 250V, 3AG4 normal-blow type fuse, mounted on the power supply, provides the overload protection. The +5V and +12V outputs are also protected by a special overload circuit.

The monitor built-in tilt-swivel assembly lets the user adjust the screen for viewing comfort.

Figure 1-2 is a simplified block diagram of a VT340+. The major parts are the CRT/bezel/chassis assembly, the terminal control module, the video amp module, the power supply/monitor (PS/M) module with the arc protection module.

1-4 Product Description

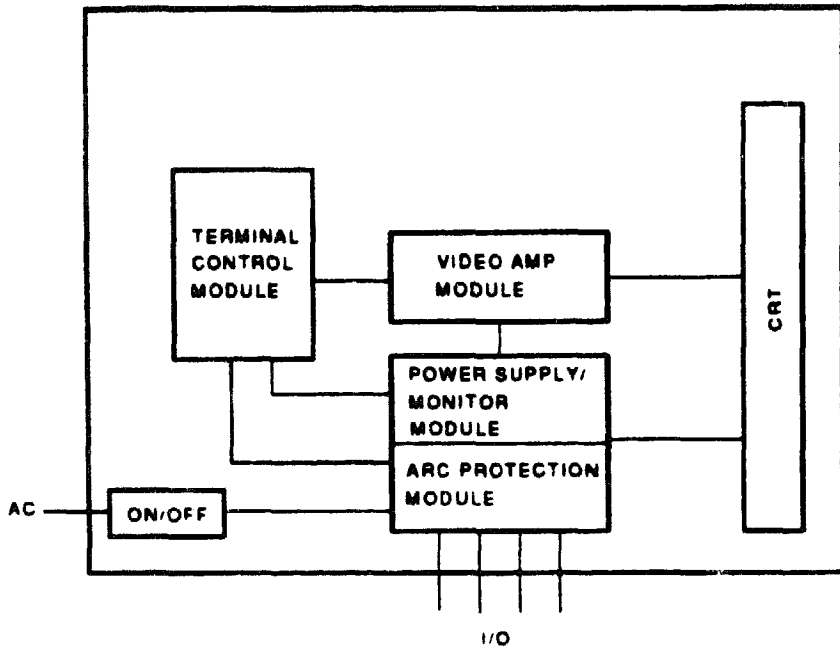

MA 2087 88

Figure 1-2 VT340+ Block Diagram

The following table describes the VT340+ interface connectors shown in Figure 1-1.

Connector	Connects the VT340+ to...
Comm1 RS232 (25-pin)	A primary host computer, directly or indirectly through a terminal server or modem).
Comm1 DEC-423 (6-pin)	A primary host computer, directly or indirectly (through a terminal server).
Comm2 DEC-423 (6-pin)	A primary host computer, directly or indirectly (through a terminal server).
Printer DEC-423 (6-pin)	A printer.
Keyboard (7-pin micro-DIN)	A keyboard.
Mouse/tablet (7-pin micro-DIN)	A mouse or graphics tablet.

The VT340+ operates on full-duplex, asynchronous communication lines.

1.3 Tools and Equipment

You need the following tools and equipment to service the VT340+ video terminal:

Tools and Equipment	Part Number
Phillips screwdriver, No. 2	29-13510-00
Anode discharge tool	29-24717-00
Video alignment tool	29-24746-00
Tuning wand	29-26128-00
Metric measuring tape	29-25342-00
Loopback connectors:	
Host EIA (25-pin)	12-15936-00
Modular jack (6-pin)	12-25083-01
Micro-DIN (7-pin)	12-25628-01
Color video service kit (without power pack)	A2-S0099-01
Color kit power packs:	
90 to 110 Vac, 50 Hz (Japan)	29-25448-00
104 to 126 Vac, 60 Hz (U.S. and Canada)	29-25449-00
198 to 242 Vac, 50 Hz (Europe and Australia)	29-25450-00

1.4 Recommended Spares List

The following table lists the part numbers for the recommended spares for the VT340+.

Spares	Part Number
Power supply/monitor module	54-20126-01
Terminal control module	54-20128-01
Video amp module	54-20130-01
Control/bracket assembly	70-22618-02

Specs	Part Number
Inlet/switch assembly	70-26546-01
Bezel/CRT/chassis assembly (Northern hemisphere)	70-26554-01
Bezel/CRT/chassis assembly (Southern hemisphere)	70-26554-02
Rear cover/base assembly	70-26567-01
Monitor/PS and protection module	70-26568-01
Rear dress panel	74-33422-01

1.5 Data Input Devices

The following data input devices can be used with a VT340+.

Device	Part Number
LK201 country keyboard	LK201-xx
Mouse	VSXXX-AA
Graphics tablet	VSXXX-AB

The symbol *xx* identifies the model. Figure C-1 lists the country models.

Testing and Troubleshooting

This chapter describes how to run a power-up self-test that is built into the VT340+ video terminal. The chapter also lists error codes and describes how to troubleshoot general problems that occur with the terminal.

2.1 Using Self-Tests

The VT340+ has seven self-tests to help you isolate failures to field replaceable units (FRUs) in the terminal. All these tests are run from the terminal Diagnostic Set-Up screen (Section 2.4). The power-up self-test runs each time you turn the terminal on.

If a test finds a faulty FRU, then adjust or replace that FRU. Then repeat the test to ensure the terminal operates correctly. Appendix C shows each FRU.

2.2 Power-Up Self-Test

This test runs automatically each time you turn the terminal on. The test checks the terminal internal memory, keyboard, and video circuitry. The test also ensures that the communication ports, printer port, and locator device port are operating correctly.

A successful power-up self-test will result in the following (Figure 2-1):

- The keyboard LED indicators are off.
- The keyboard makes the bell tone sound.
- A "VT340+ OK" message appears on a screen together with the firmware revision level and a set-up screen copyright message. This message disappears when:
 - The terminal receives any character except XON, XOFF, or NULL
 - You press any key on the keyboard

2-2 Testing and Troubleshooting

- You leave the terminal on but inactive for 30 minutes

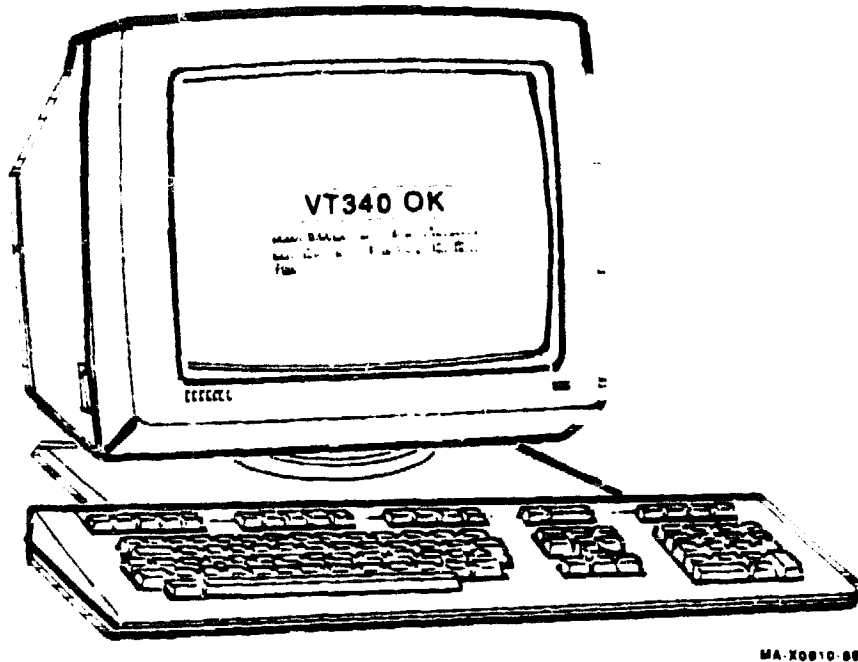

Figure 2-1 Successful Power-Up Self-Test Display

2.3 If the Test Finds an Error

If the test finds an error, do the following:

1. Look at the screen. The terminal will display one or more error messages. Each error message starts on a new line at the left margin of the display. Section 2.7 describes the error messages.
2. If the screen display is faulty, check the LED indicators on the keyboard. They also display the error code.
3. If other problems occur, see Section 2.8. It lists some common operating problems, their probable causes, and suggested solutions.

2.4 Diagnostic Set-Up Screen

Use the Diagnostic Set-Up screen (Figure 2-2) to run one or more of the seven self-tests on the terminal. Section 2.5 describes each test.

You can run the five loopback tests and the power-up self-test in any combination. Each test runs until it is complete, or until the terminal detects an error. You must run the screen tests separately from the loopback tests and power-up test.

NOTE

If you are unfamiliar with the terminal set-up screens, refer to Chapter 5.

DIAGNOSTIC SET-UP		VT340 Version V3 0
Feature	Current Setting	
COMM1 External Loopback (25)	disabled	
Comm1 External Loopback (6)	disabled	
Comm2 External Loopback (6)	disabled	
Printer External Loopback	disabled	
Locator External Loopback	disabled	
Power-Up Test	disabled	
Run Tests	Repeat Tests	
Run Screen Tests		
Use up/down arrow keys to select feature. right/left arrow keys to change current setting To return to the Set-Up Directory, press SELECT key Copyright © 1989, Digital Equipment Corporation-All Rights Reserved		
1 1 (01 01)	Overstrike Mode	Printer None

MA-30881-89

Figure 2-2 Diagnostic Set-Up Screen

2.4.1 Diagnostic Set-Up Screen Format

The top half of the Diagnostic Set-Up screen has two columns; the Feature column and Current Setting column. The following table describes both columns.

Column	Description
Feature	Lists the individual loopback tests and the power-up test.
Current Setting	Shows you if a test is enabled or disabled. You must enable a test before you can run it. Initially, all tests are disabled.

2.4.2 How to Change a Current Setting of a Test

Use the ↑ and ↓ keys to move the cursor to the selected test in the feature column. Use the ← and → keys or **Enter** to change the current setting (enabled or disabled) of the test.

2.4.3 How to Run a Self-Test

You can run one or more of the terminal's seven self-tests and as many times as you like. Before you run a loopback test, you must connect a loopback connector to the selected port (Section 2.5.1). To run the screen tests, see Chapter 4. To run a self-test, do the following:

1. Press the **Set-Up** key. The Set-Up Directory appears on the screen.
2. Use the arrow keys to move the cursor to **Diagnostic Set-Up**. Press the **Enter** key to display the Diagnostic Set-Up screen.
3. Use the arrow keys to enable each test you want to run.
4. Use the arrow keys to move the cursor to **Run Test** or **Repeat Tests**.

Run Test performs an enabled test one time.

Repeat Tests performs an enabled test continuously.

5. Press the **Enter** key to start the self-tests.

NOTE

The continuous test run ends when an error occurs or when you turn the power off. The keyboard does not make a bell tone sound during a continuously running test.

2.5 Diagnostic Self-Tests

You can select seven different self-tests from the Diagnostic Set-Up screen. The first five tests are loopback tests that check the three communication ports of the terminal, the printer port, and the locator device port.

The sixth test is the power-up self-test. The last test is a set of screen patterns that are used to adjust the video display (Chapter 4).

2.5.1 Loopback Tests

All five loopback tests work the same way. You plug a loopback connector into the port you want to test. The loopback connects the port transmit and receive data lines.

When you run the test, the terminal sends a predefined set of characters on its transmit line and receives them on its receive line. If the characters do not match when compared by the terminal, an error message appears on the screen.

You must use a loopback connector or the test will fail. The following table lists the loopback connectors and their part numbers.

Loopback Connector	Part Number
Host EIA port (25-pin)	12-15336-00
Modular jack (6-pin)	12-25083-01
Micro-DIN (7-pin)	12-25628-01

Figure 2-3 shows the five VT340+ ports and the three loopback connectors. Note that the VT340+ has two *Comm1* connectors.

2-6 Testing and Troubleshooting

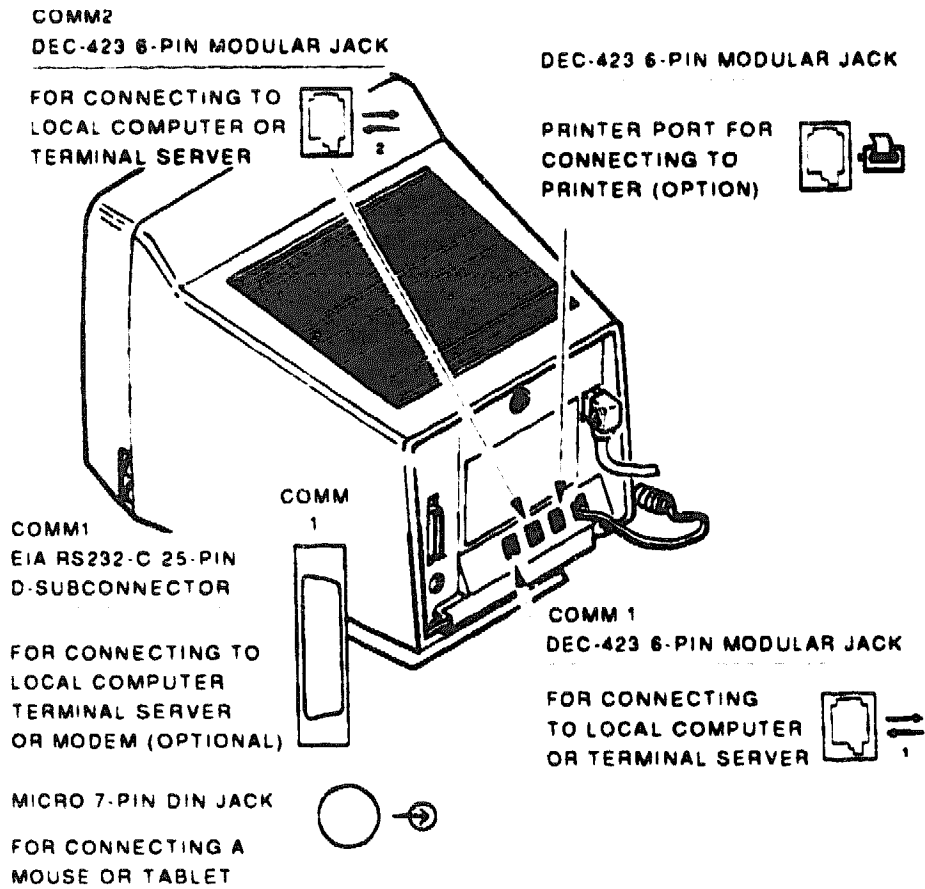

LOOPBACK CONNECTORS

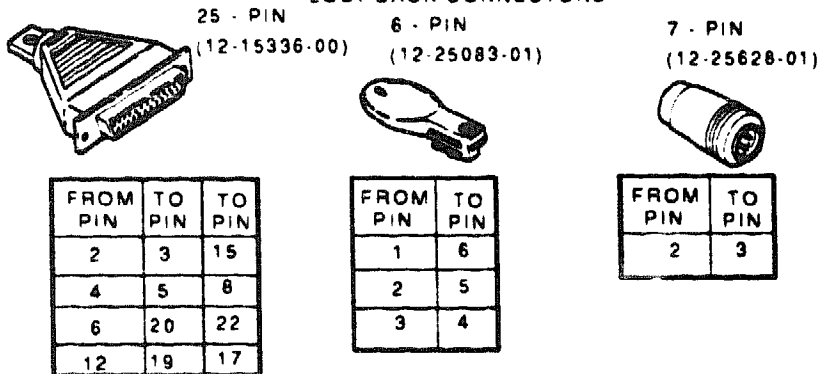

MA-X0611 62

Figure 2-3 VT340+ Ports and Loopback Connectors

How to Run a Loopback Test

To run a loopback test:

1. Turn the terminal off.
2. Disconnect the cable from the port you are testing.
3. Connect the appropriate loopback connector to the port.

Test	Loopback Connector
Comm1 (25-pin)	12-15336-00
Comm1 (6-pin)	12-25083-01
Comm2 (6-pin)	12-25083-01
Printer (6-pin)	12-25083-01
Locator (7-pin)	12-25628-01

4. Turn the terminal on.
5. Use the Diagnostic Set-Up screen to run the test.

A successful test will result in the following:

- The keyboard LED indicators are off.
- The keyboard makes a bell tone sound.
- A "VT340+ OK" message appears on the screen.

If the Test Finds an Error

If the test finds an error, your screen may display one of the following error messages. See Section 2.7 for more details.

For a Comm1 25-pin test, the following error message could appear:

```
VT340+ Comm1 Port Data Error - - 2
VT340+ Comm1 Port Control Error - - 3
```

There is no loopback test for the keyboard. However, if the keyboard is faulty, the following error message could appear:

```
Keyboard Error - - 4
```

For a Comm1 6-pin test, the following error message could appear:

```
VT340+ Comm1 DEC-423 Data Error - - 5
```

For a Comm2 6-pin test, the following error message could appear:

VT340+ Comm2 DEC-423 Data Error - - 6

For a Printer 6-pin test, the following error message could appear:

VT340+ Printer Port Error - - 7

For a Locator 7-pin test, the following error message could appear:

VT340+ Locator Port Error - - 8

2.5.2 Power-Up Test

This test is the same as the power-up self-test described in Section 2.3. If you use **Repeat Tests** to run this test, the test runs continuously until an error occurs or until you turn the power off.

2.5.3 Screen Tests

These tests are a series of calibration and alignment displays. You use these patterns to adjust the display height, width, and linearity. You do not need a loopback connector for these tests. See Chapter 4 for the procedures used for these tests.

2.6 Printer Problems

If a printer connected to a VT340+ does not print, use the following steps to isolate the problem to the printer or terminal.

1. Run the power-up self-test (Section 2.3). If the terminal passes the test, go to step 2.
2. Run the printer external loopback test (Section 2.5.1). If the terminal passes this test, go to step 3.

NOTE

If the terminal passes the above tests and it runs correctly, the problem is probably not in the VT340+ terminal.

3. Test the printer. Refer to its pocket service guide for correct procedures. If the printer operates correctly, go to step 4.

4. Check the following set-up features to ensure your terminal and printer are compatible. If you are unfamiliar with the terminal set-up screens, see Chapter 5.
 - Check the **Printer Assignment** feature in the **Global Set-Up** screen. Make sure the printer is assigned to the session you are in, otherwise it will not print from your session.
 - Check the printer status on the status line in set-up. The following table lists the printer status and their meaning.

Printer Status	Meaning
Ready	The printer is available to print.
Not Ready	The printer port is not available to print.
None	The printer is turned off or not connected to the printer port.
Auto Print	When you or a host computer end a data line with a carriage return, the terminal automatically sends the line to print.
Controller	Information from the host goes directly to the printer.
Busy	The printer port is performing another operation (such as Local Print).
Not assigned	The printer port is not assigned to the active session.

- Check the following features in the **Printer Set-Up** screen. The settings for the printer and terminal must match.
 - Print speed (75 to 19.2K baud)
 - Character format (8- or 7-bit; even, odd, or no parity)
 - Stop bits (1 or 2)
 - Flow control (XON/XOFF, DSR/DTR)
5. Make sure you are using the correct cable between the printer and terminal (Appendix D). Make sure the connections are secure at both ends of the cable.
 6. Put the terminal in the local state by using the **On Line/Local** feature in the **Global Set-Up** screen. Then exit the **Set-Up** screen and type some characters on the screen.

7. Press the **Local Print** (F2) key. The data on your screen should print out if the printer is operating correctly. If the data does not print, go back to step 3.

2.7 Self-Test Error Messages and Codes

If the screen displays an error message, see Table 2-1. It lists the FRU you must replace to correct the problem.

If the VT340+ fails the power-up self-test, see Table 2-2.

If there is a problem with the screen display, check the keyboard LED indicators. The LED indicators always display the error code for the test currently running. This test must run successfully before your terminal clears the LED error code.

If the LEDs flash the same pattern repeatedly, or flash an alternating pattern, or do not turn on at all, replace the terminal control module (Section 3.3). Refer to (Table 2-2) for troubleshooting procedures.

Table 2-1 VT340+ Display Error Messages

Error Message	Solution
VT340+ NVR Error—1	Recover from nonvolatile memory (NVR) (Section 2.7.1). Replace the terminal control module (Section 3.3).
VT340+ Comm1 Port Data Error—2	Replace the terminal control module (Section 3.3).
VT340+ Comm1 Port Control Error—3	Replace the terminal control module (Section 3.3).
VT340+ Keyboard Error—4	See if the keyboard is plugged in. Turn the VT340+ power off, then turn the power on again. If the error continues, replace the keyboard (Section 3.11). If the error still continues, replace the PS/M module (Section 3.6). If the error still continues, replace the terminal control module (Section 3.3).
VT340+ Comm1 DEC-423 Data Error—5	Replace the PS/M module (Section 3.6). If the error continues, replace the terminal control module (Section 3.3).
VT340+ Comm2 DEC-423 Data Error—6	Replace the PS/M module (Section 3.6). If the error continues, replace the terminal control module (Section 3.3).

Table 2-1 (Cont.) VT340+ Display Error Messages

Error Message	Solution
VT340+ Printer Port Error—7	Replace PS/M module (Section 3.6). If the error continues, replace the terminal control module (Section 3.3).
VT340+ Locator Port Error—8	See if the mouse/tablet is plugged in. Turn the VT340+ power off, then turn the power on again. If the error continues, replace the mouse/tablet (Section 3.12). If the error still continues, replace the terminal control module (Section 3.3).

2.7.1 NVR Error—1 Code

If a "VT340+ NVR Error—1" message appears when you turn the terminal on, there is a problem with the terminal NVR that stores the factory-default set-up settings. You can save the factory-default settings in NVR as follows. This procedure applies to single or double sessions.

1. Press the **Set-Up** key. The Set-Up Directory appears.
2. Move the cursor to **Recall Factory Default Settings** and press the **Enter** key.
3. Move the cursor to **Global Set-Up** and press the **Enter** key. The Global Set-Up screen appears.
4. Check if the **Terminal Comm Ports** setting is **S1=Comm1, S2=Comm2**. If it is correct, then press the **Select** key to return to the Set-Up Directory. If the setting is not correct, then change it to **S1=Comm1, S2=Comm2**. Finally, press the **Select** key to return to the Set-Up Directory screen.
5. Move the cursor to **Save Current Settings** and press the **Enter** key. A Done message appears at the bottom of the screen.
6. Move the cursor to **User-Defined Key Set-Up** and press the **Enter** key. The User-Defined Key Set-Up screen appears.
7. Move the cursor to **Save User-Defined Keys** and press the **Enter** key. A Done message appears at the bottom of the screen.
8. Press the **Select** key to return to the Set-Up Directory screen.
9. Move the cursor to **Color Set-Up** and press the **Enter** key. The Color Set-Up screen appears.

10. Move the cursor to **Save Color Map** and press the **Enter** key. A **Done** message appears at the bottom of the screen.
11. Press the **Set-Up** key to exit set-up.
12. Press the **Switch Session** key to enter the other session.
13. Press the **Set-Up** key to display the Set-Up Directory again.
14. Move the cursor to **Recall Factory Default Settings** and press the **Enter** key. A **Done** message appears at the bottom of the screen.
15. Move the cursor to **Save Current Settings** and press the **Enter** key. A **Done** message appears at the bottom of the screen.
16. Press the **Set-Up** key to exit set-up.
17. Turn the terminal power off, then turn the power on again. If the "VT340+ NVR Error—1" message still appears on the screen, the terminal has a hardware failure. Refer to Table 2-1 to determine the corrective action.

2.8 Troubleshooting General Problems

Table 2-2 lists some common operating problems, their probable causes, and suggested solutions.

Table 2-2 VT340+ Troubleshooting Chart

Symptom	Probable Cause	Solution
There is no "VT340+ OK" message, power indicator off, no bell tone.	VT340+ is not plugged in, or no power at power outlet	Plug in VT340+, or try another wall power outlet.
	AC power cord	Check for an open line or shorts.
	Power switch assembly	Check the connections on the PS/M module (Section 3.6).
	PS/M module	Replace the PS/M module (Section 3.6).
Keyboard LEDs are blinking.	Terminal control module	Replace the terminal control module (Section 3.3).
Keyboard LEDs stay on.	Terminal control module	Replace the terminal control module (Section 3.3).

Table 2-2 (Cont.) VT340+ Troubleshooting Chart

Symptom	Probable Cause	Solution
Compressed raster, there is no video.	Video cable connections	Check the connections from the PS/M module to the CRT yoke.
Raster, there is no video.	Video amp module	Check module connectors and reconnect if necessary. Check the CRT socket connection. Replace the PS/M module (Section 3.6).
CRT filaments are not lit.	CRT/bezel/chassis assembly	Check the CRT socket connection. Replace the CRT/bezel/chassis assembly (Section 3.9).
The "VT340+ OK" display is present, power indicator off.	LED assembly	Check the connection to the power supply/monitor module. Replace the CRT/bezel/chassis assembly (Section 3.9). Replace the PS/M module (Section 3.6).
Screen display is distorted.	Monitor is out of alignment Monitor circuit Terminal control module CRT/bezel assembly	Perform the alignment procedure (Chapter 4). Replace the PS/M module (Section 3.6). Replace the terminal control module (Section 3.3). Replace the CRT/bezel assembly (Section 3.9).
There is no bell tone.	Bell is disabled Keyboard speaker is faulty	Set Warning Bell to "high" or "low" in the Keyboard Set-Up. Replace the keyboard (Section 3.11).

Table 2-2 (Cont.) VT340+ Troubleshooting Chart

Symptom	Probable Cause	Solution
Different characters appear on the screen than were typed in the local mode.	Alternate character set selected	Use the Recall Saved Settings in the Set-Up directory.
	Keyboard	Replace the keyboard (Section 3.11).
	Terminal control module	Replace the terminal control module (Section 3.3).
Different characters appear on screen than were typed while on-line with the host (terminal works in local).	Transmit and receive speeds are set wrong	Set speeds to match the host (Communications Set-Up).
	Bits per character or parity setting is wrong	Set Character Format to match the host (Communications Set-Up).
	Stop Bits setting is wrong	Set Stop Bits to match the host (Communications Set-Up).
Screen display does not scroll. Hold Session indicator is on.	Screen display is locked	Press the Hold Session (F1) key to release.
Terminal appears to be locked, does not respond to the data from the host.	Wrong session selected	Press the Switch Session key.
	LAT is disconnected	Press the Set-Up key. Move the cursor to Enable Sessions and press the Enter key. Press the Set-Up key to exit set-up. Turn the power off (0), then turn the power on (1) again. Login to the terminal and establish dual sessions.
	Incorrect communications setting	Clear the settings by using the Clear Communications field in the Set-Up directory.

Table 2-2 (Cont.) VT340+ Troubleshooting Chart

Symptom	Probable Cause	Solution
Screen goes blank after a successful power-up, then is inactive for one-half hour. Power indicator is on.	CRT Saver feature in the Global Set-up is enabled	Press any key to reactivate the screen.
Messages are incomplete.	XON/XOFF is not selected	Set Transmit Flow Control to XON/XOFF (Communications Set-Up).
	Comm port connections	Check cables at the comm ports.
	Terminal control module	Replace the terminal control module (Section 3.3).
Terminal does not respond to an escape sequence.	Incorrect Terminal Mode selected	Check the setting of the Terminal Mode feature in the General Set-Up.

3

Removing and Replacing FRUs

This chapter shows you how to remove and replace the VT340-G field replaceable units (FRUs). Appendix C contains exploded view drawings that show the location, part name, and part number of each FRU.

CAUTION

Use a static protection kit (PN 29-11762-00) when handling any internal components.

NOTE

Refer to Section 3.10 when you need to remove and dispose of a defective CRT.

3.1 Rear Panel

To remove the rear panel:

1. Turn the terminal's power switch off (0).
2. Grasp the top of the rear panel and pull it towards you.
3. If there is a cable connected to the 25-pin Comm1 port, slide the panel down the cable and away from the terminal.

Otherwise, lower the panel and remove it. Set the panel aside.

To install the panel, reverse steps 1 through 3.

3-2 Removing and Replacing FRUs

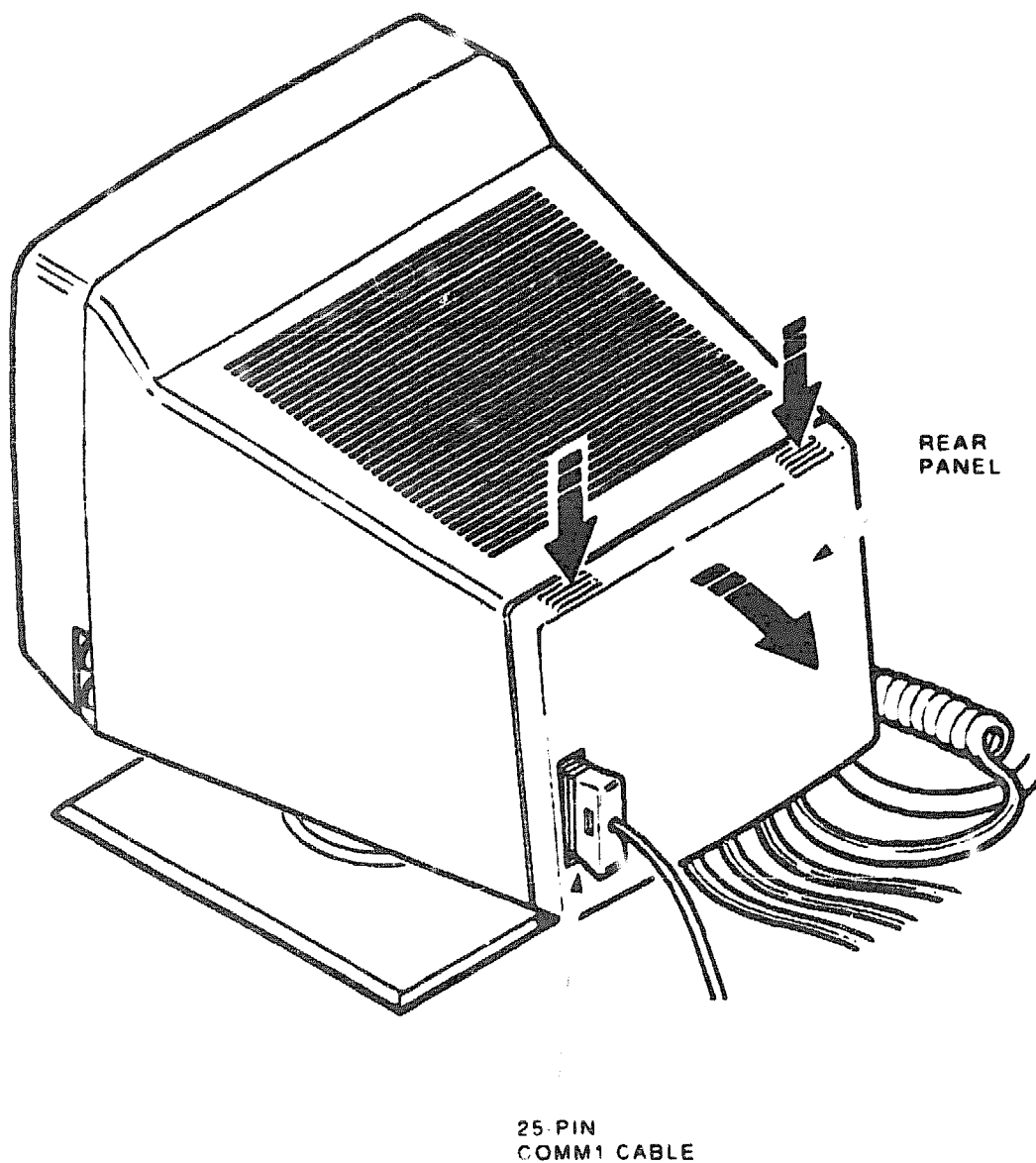

MA-10887-89

3.2 Rear Enclosure/Base Assembly

To remove the rear cover/base assembly:

1. Remove the rear panel (Section 3.1).
2. Turn the terminal power switch off (0).
3. Unplug the power cord from the wall outlet, then from the terminal.

4. Disconnect the keyboard cable from the terminal.
5. Disconnect all other cables from the rear of the terminal including the:
 - host port cable(s)
 - printer cable
 - locstor device cable

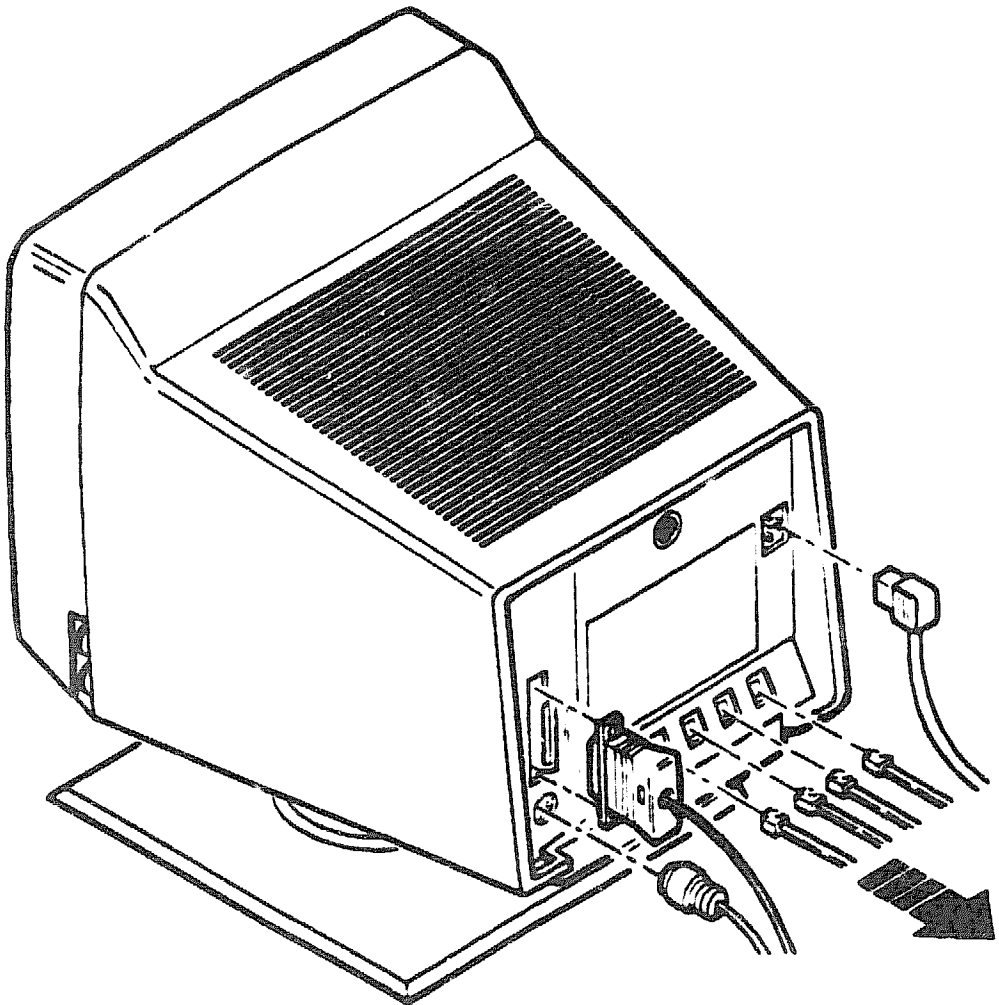

MA X0888 89

6. Place a piece of paper on a flat working surface. Carefully place the terminal face down on the paper. The paper will prevent scratches on the monitor bezel.

3-4 Removing and Replacing FRUs

NOTE

You must clean the face of the CRT after you service the terminal.

7. Use a 5/16 inch nutdriver to loosen the captive screw on the rear panel. The screw holds the rear enclosure/base assembly to the chassis.

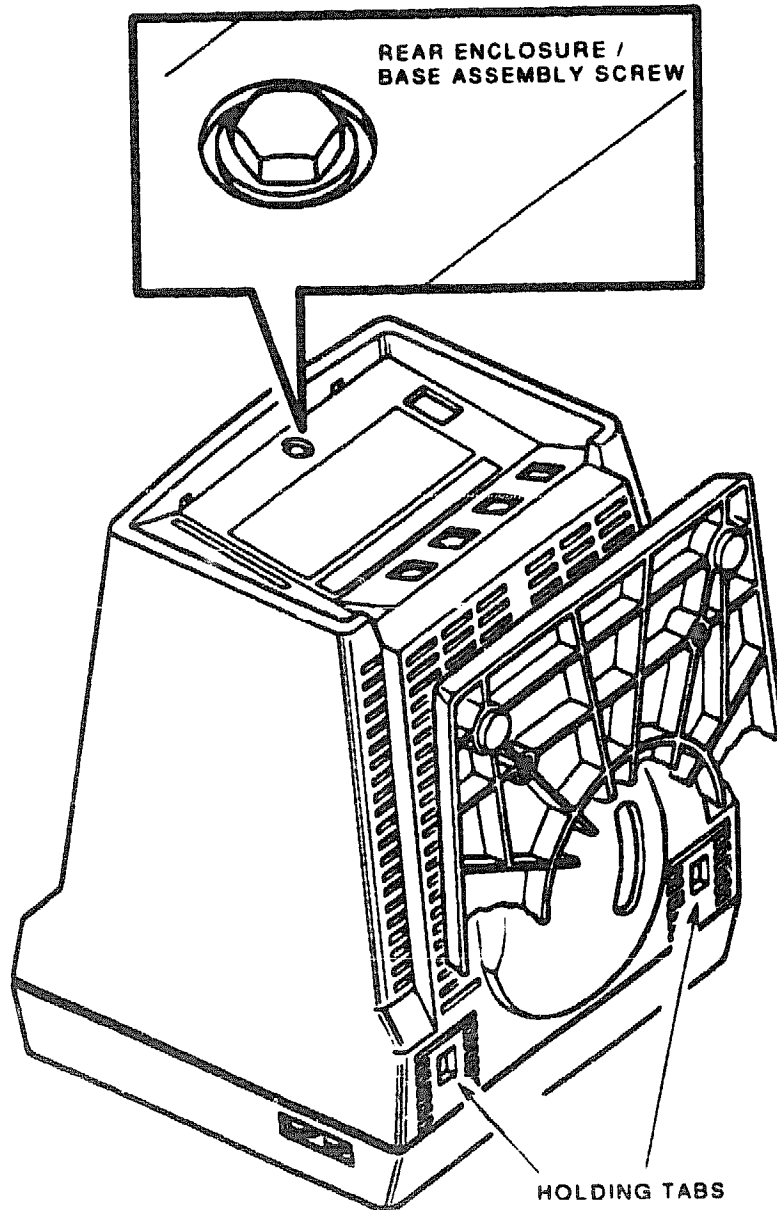

MA-X0889-89

WARNING

The next step exposes you to the CRT anode, which stores a high voltage. Use caution while the rear enclosure is off the terminal.

8. Remove the rear enclosure/base assembly by pressing the two holding tabs in and sliding the cover straight up.

To install the rear enclosure/base assembly, reverse steps 1 through 8.

CAUTION

When you install the rear enclosure/base assembly, carefully align the holding tabs and screw hole.

3.3 Terminal Control Module

To remove the terminal control module:

NOTE

If you have to discharge the CRT before removing the terminal control module, refer to Section 3.4.

1. Remove the rear panel (Section 3.1).
2. Remove the rear enclosure/base assembly (Section 3.2).

CAUTION

Use a static protection kit (PN 29-11762-00) when handling any internal components.

3. Disconnect the 40-pin ribbon cable from connector J3 on the terminal control module.
4. Pull down the metal box that protects the 16-pin ribbon cable and disconnect the cable from the terminal control module connector J4.
5. Loosen the two phillips screws that hold the terminal control module to the chassis.
6. Press the bottom of the module to loosen it, and slide the module up, then carefully pull it toward you.

3-6 Removing and Replacing FRUs

To install the terminal control module, reverse steps 1 through 6.

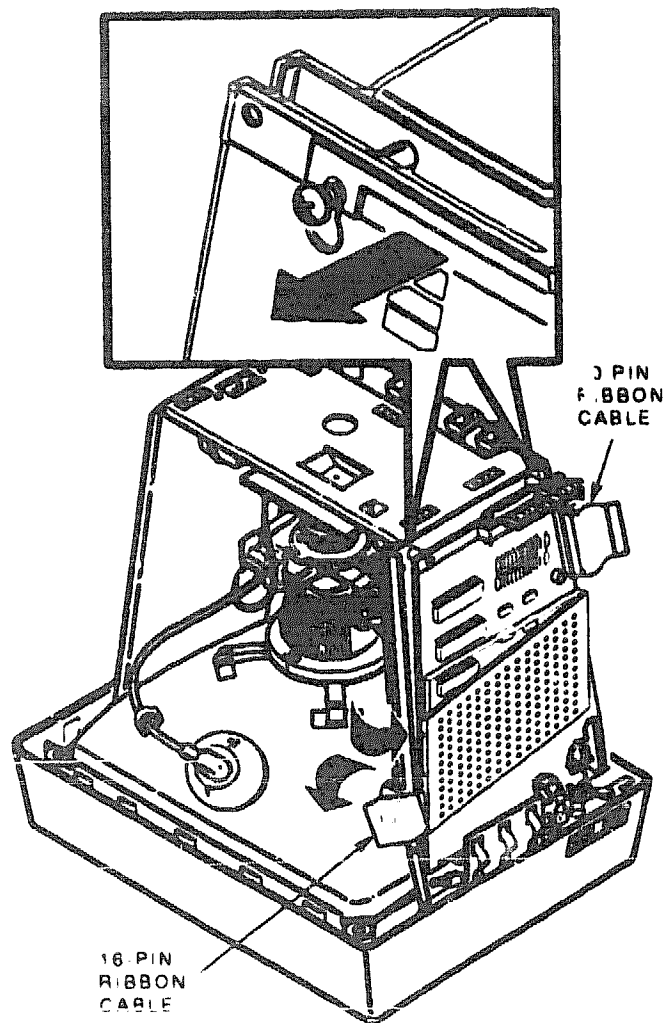

MA X1308 89

3.4 Discharging the CRT

To discharge the CRT:

WARNING

The following steps expose you to the CRT anode, which may store a high voltage. Be extremely careful.

1. Remove the rear panel (Section 3.1).
2. Remove the rear enclosure/base assembly (Section 3.2).
3. Attach the clip end of the anode discharge tool (PN 29-24717-00) to the metal chassis.
4. Push the probe end under the soft plastic anode connector cap, until you feel the probe touching the anode connector.

CAUTION

Do not scratch the glass of the CRT when discharging the anode.

5. Hold the probe against the anode connector for at least 3 seconds, then remove the probe.

3-8 Removing and Replacing FRUs

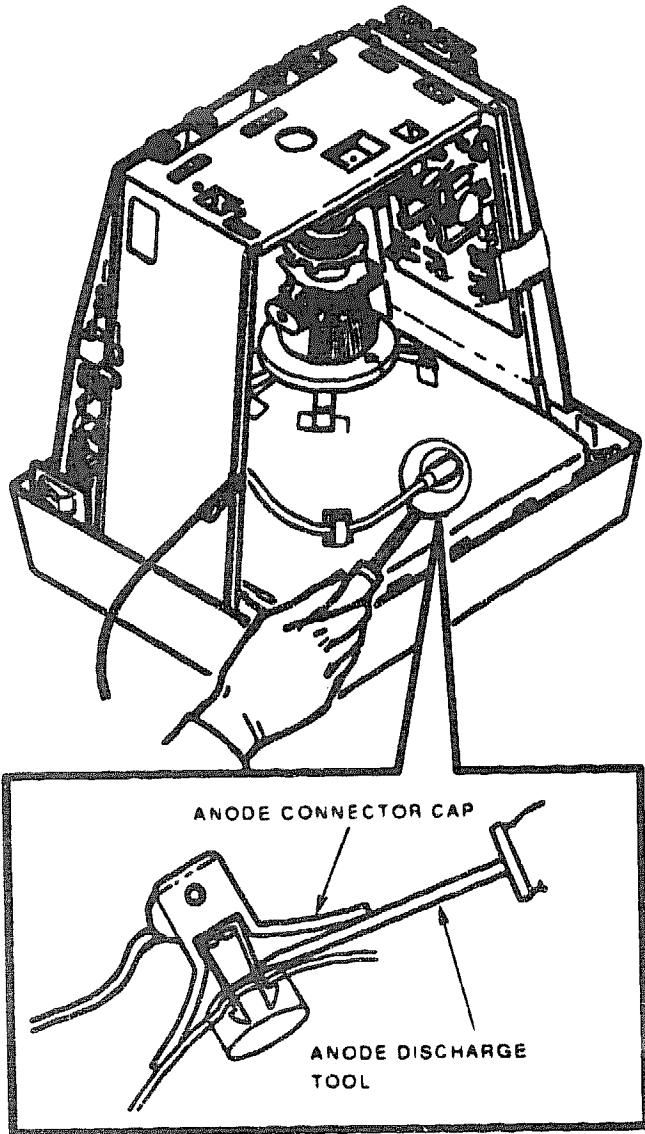

MA-X0070-89

NOTE

If you are removing the video amp module, you do not have to perform this step.

6. Remove the CRT anode connector from the CRT, as shown.

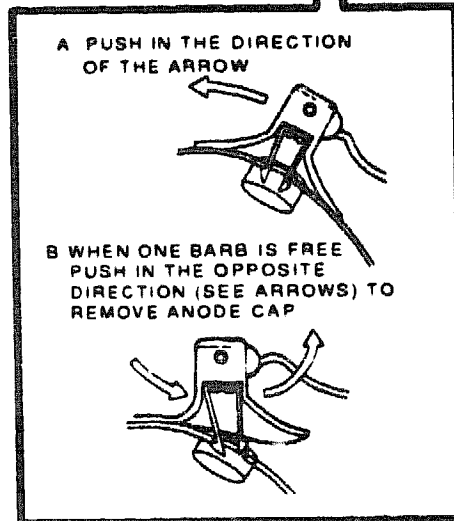
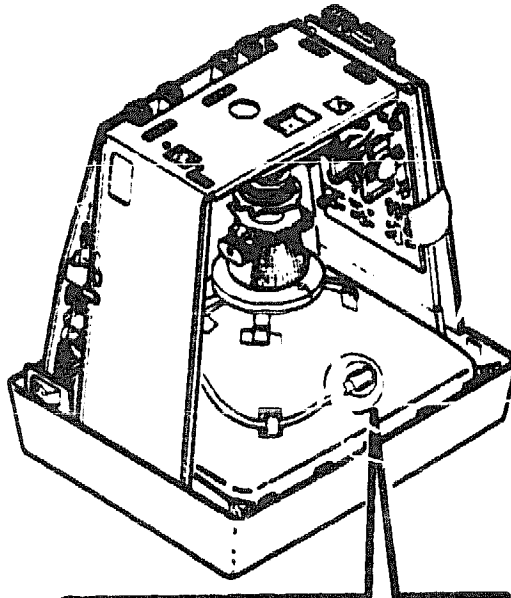

3.5 Video Amp Module

To remove the video amp module:

1. Remove the rear panel (Section 3.1).
2. Remove the rear enclosure/base assembly (Section 3.2).

WARNING

You must discharge the CRT before removing the video amp module. However, you do not have to remove the anode connector.

3. Discharge the CRT (Section 3.4), but do not remove the anode connector.
4. Pull down the metal box that protects the 16-pin ribbon cable and disconnect the cable from terminal control module connector J4.
5. Disconnect the 6-wire cable from the video amp module connector J304 (keyed).
6. Disconnect the 6-wire cable from the arc protection module connector J704 (keyed).

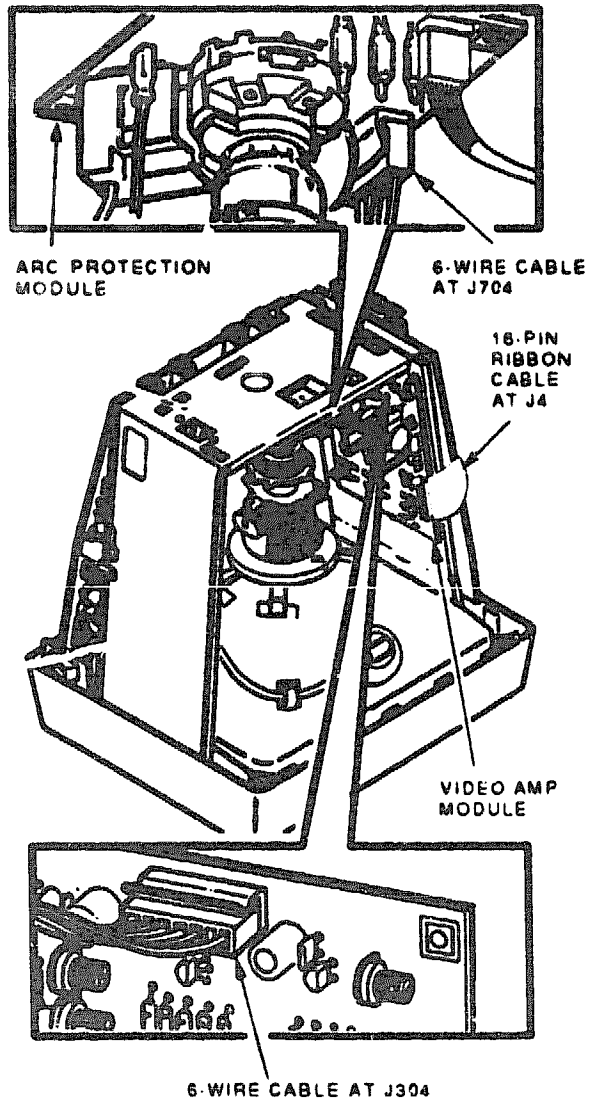

3-12 Removing and Replacing FRUs

7. Remove the video amp module by squeezing the module's two standoffs with the needlenose pliers.

To install the video amp module, reverse steps 1 through 7. The video amp module has two notches on the side. Place these notches on the legs of the chassis and snap the module into the standoffs.

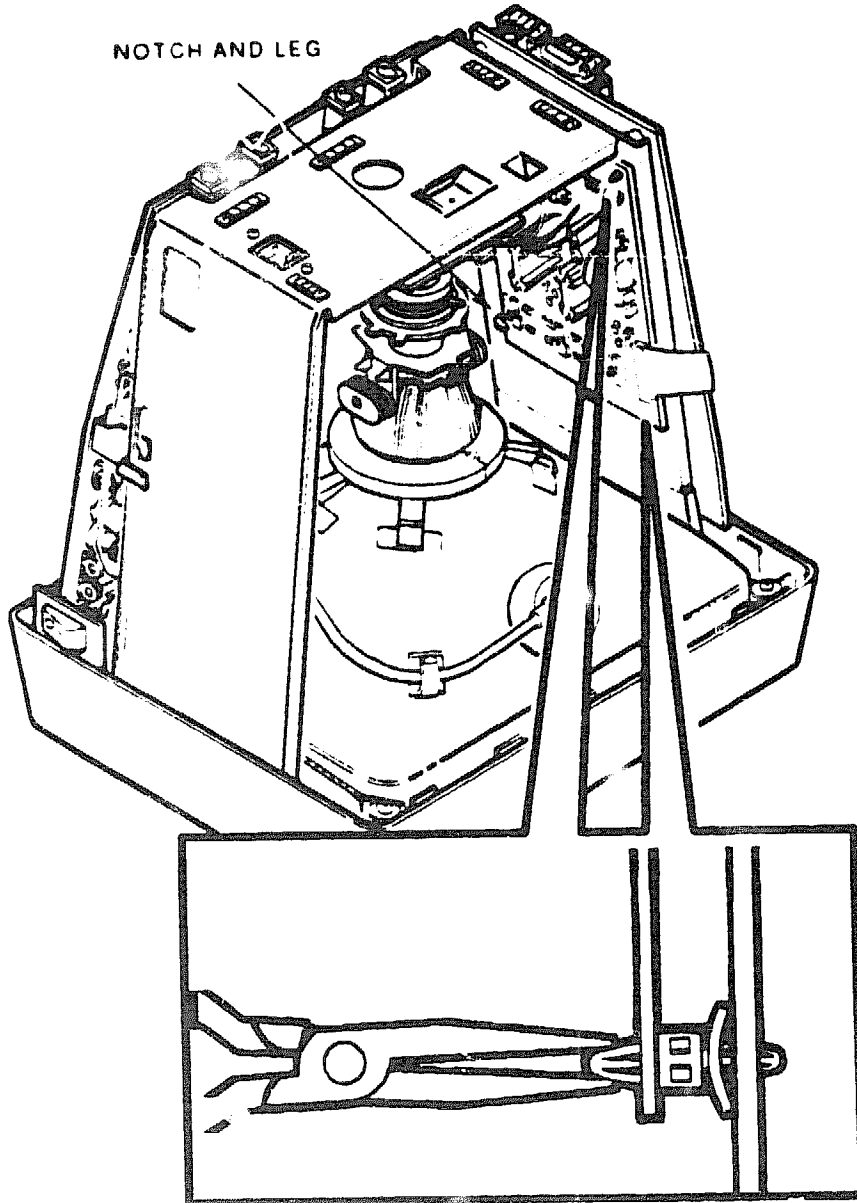

3.6 Power Supply/Monitor Module and Arc Protection Module

To remove the power supply/monitor (PS/M) module and arc protection module:

1. Remove the rear panel (Section 3.1).
2. Remove the rear enclosure/base assembly (Section 3.2).

WARNING

You must discharge the CRT (Section 3.4) before removing the PS/M module and arc protection module. Keep the CRT anode connector detached from the CRT.

3. Disconnect the 40-pin ribbon cable from the terminal control module connector J3.
4. Remove the wires from the two cable tie wraps inside the chassis.
5. Loosen the two phillips screws that hold the PS/M module to the chassis.
6. Gently slide the PS/M module up and off the screws to expose the cables.

3-14 Removing and Replacing FRUs

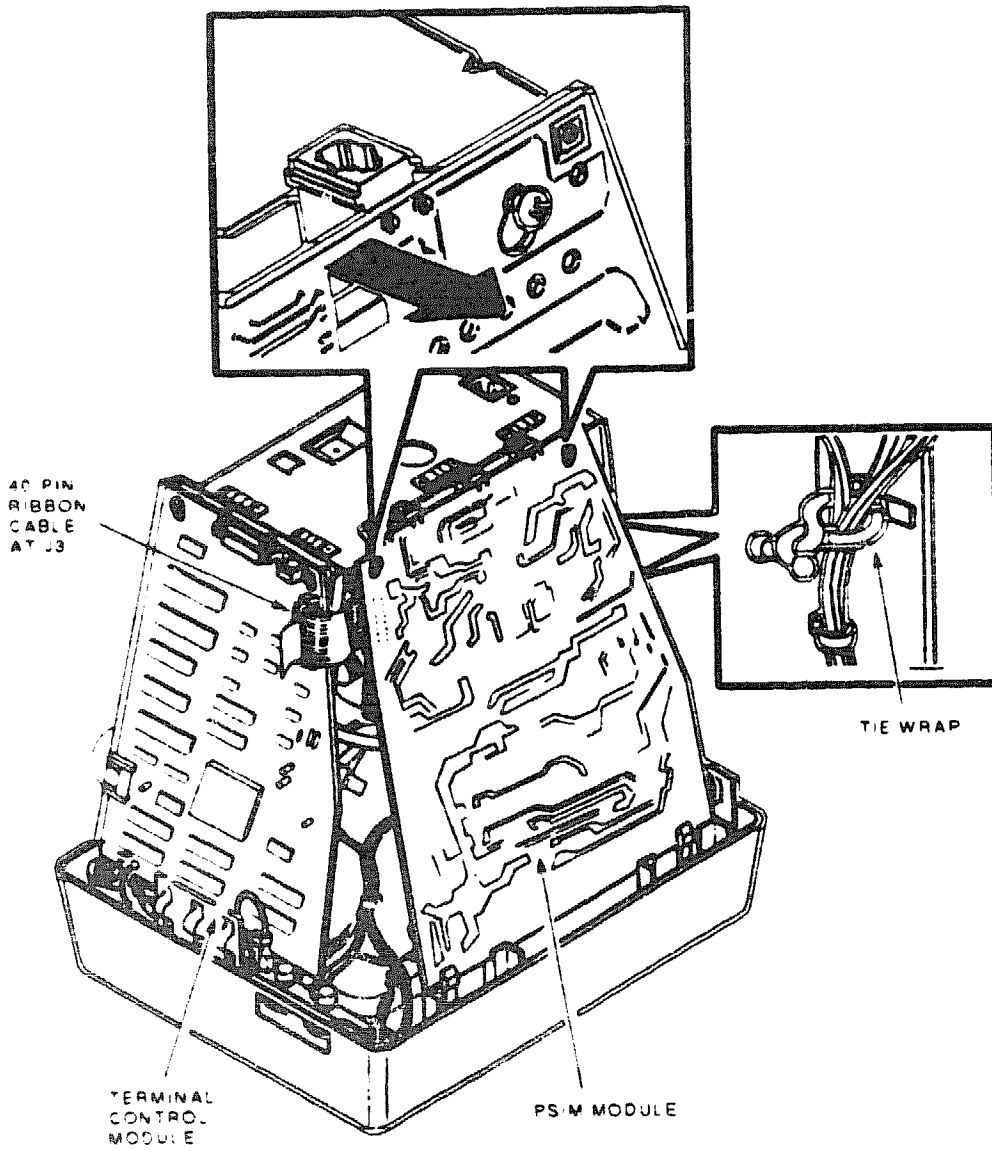

MA 10072 89

7. Disconnect the following cables/connectors on the PS/M module:

- 2-wire (LED) cable to connector J901 (locked)
- 5-wire (control/bracket) cable to connector J601 (locked)

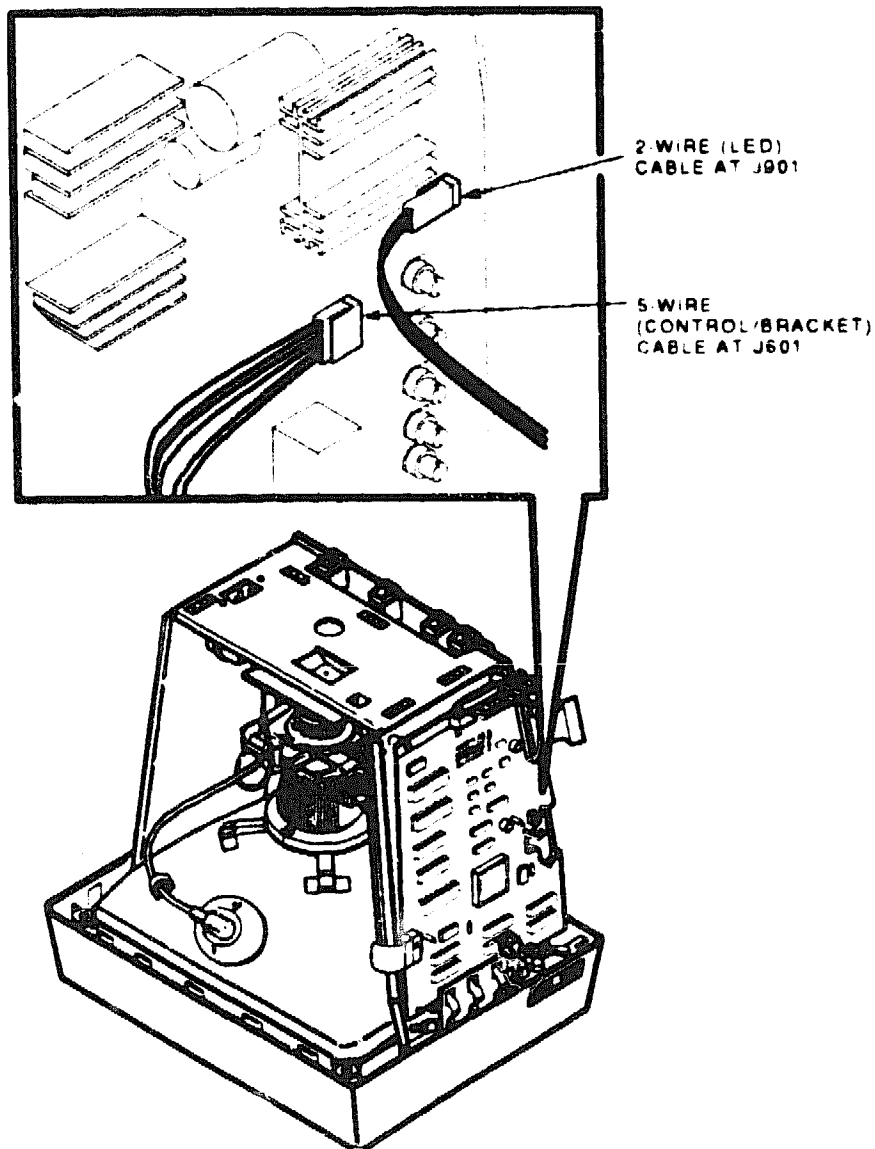

3-16 Removing and Replacing FRUs

- 2-wire (power switch) cable to connector J801 (locked)
- 2-wire (degauss) cable to connector J711 (keyed)
- 4-wire (yoke) cable to connector J600

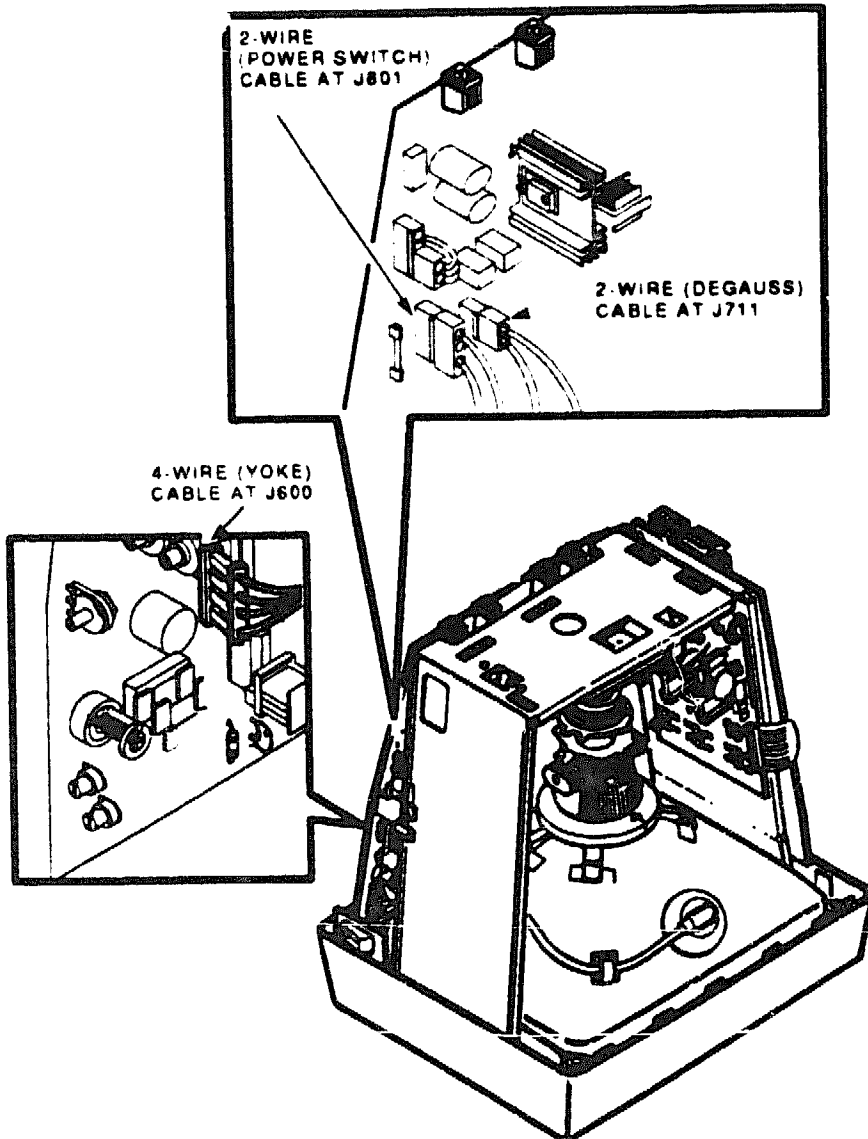

8. Disconnect the following cables from the PS/M module:

- 4-wire cable to connector J702 on the arc protection module (on the back of the CRT)
- 6-wire cable to connector J304 on the video amp module

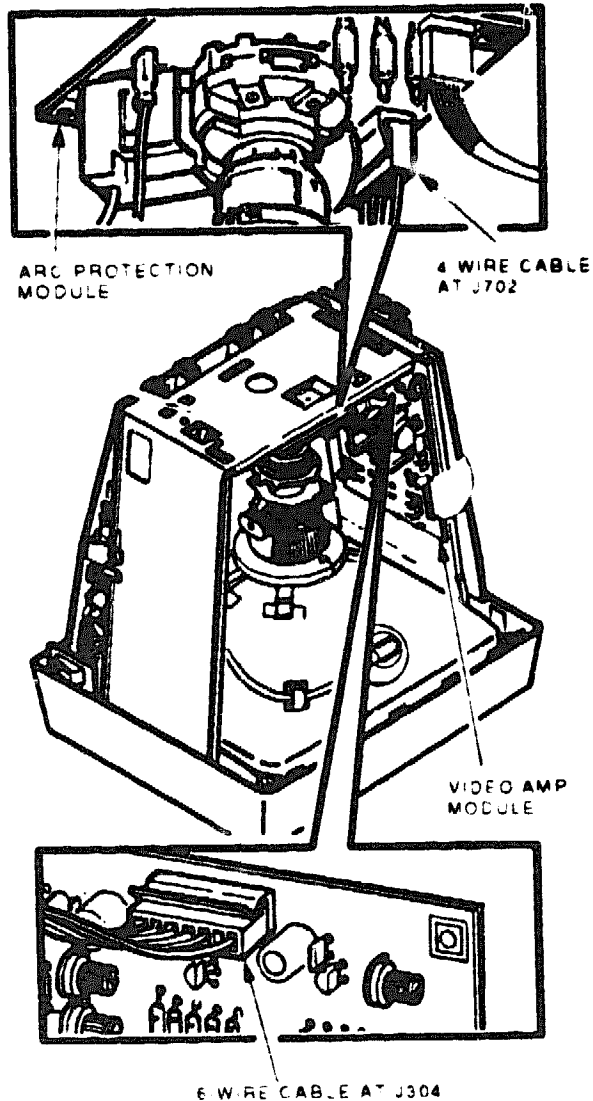

3-18 Removing and Replacing FRUs

9. Disconnect the 6-wire (video amp) cable to connector J704 (keyed) on the arc protection module.
10. Disconnect the following ground wires:
 - From the grounding braid to connector J701 on the arc protection module
 - From the arc protection module (P703) to the chassis

GROUND WIRE AT P703

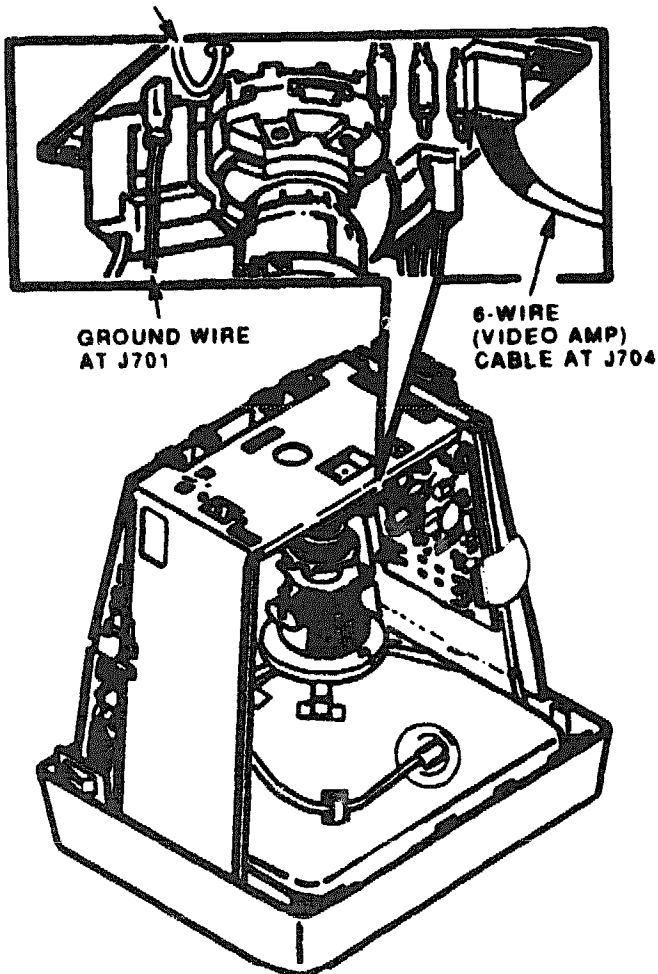

GROUND WIRE
AT J701

6-WIRE
(VIDEO AMP)
CABLE AT J704

11. Carefully lift the arc protection module socket off the neck of the CRT by using a gentle side-to-side motion. The arc protection module is still connected to the PSM module by a soldered wire.

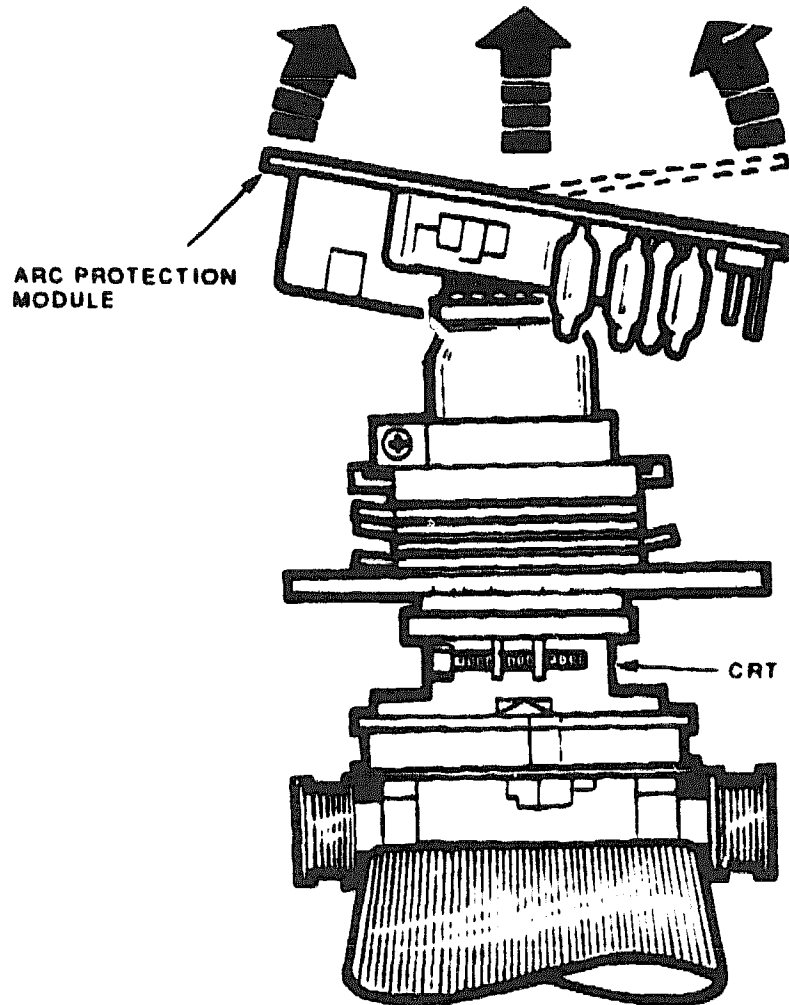

3-20 Removing and Replacing FRUs

12. Remove the PS/M module and arc protection module from the chassis.

To install the PS/M module and arc protection module:

- a. Refer to (Section 3.6.1) and (Section 3.6.2).
- b. Refer to the following list for modules, cables, and tie wraps.
- c. Reverse steps 1 through 11.

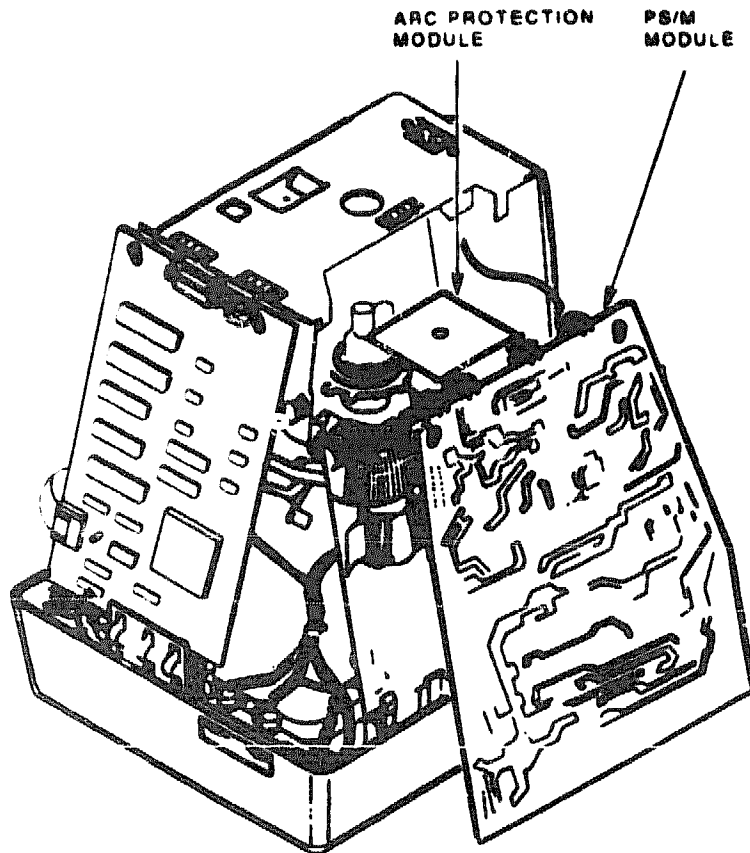

MA 20076 00

The following is a list of modules, cables, and tie wraps that must be connected to properly install the arc protection module and the PS/M module.

- PS/M module to the chassis.
- Arc protection module to the CRT neck.
- Ground wire from the arc protection module (P703) to the chassis.
- Ground wire from the grounding braid to the arc protection module connector J701.
- 6-wire cable from the video amp module to the arc protection module connector J704.
- 6-wire cable from the PS/M module to connector J304 on the video amp module.
- 4-wire cable from the PS/M module to connector J702 on the arc protection module.
- 4-wire (yoke) cable to connector J600 on the PS/M module.
- 2-wire (degauss) cable to connector J711 on the PS/M module.
- 2-wire (power switch) cable to connector J801 on the PS/M module.
- 5-wire (control/bracket) cable to connector J601 on the PS/M module.
- 2-wire (LED) cable to connector J901 on the PS/M module.
- Two tie wraps holding wires inside the chassis.
- 40-pin ribbon cable from the terminal control module connector J3.
- Anode connector to the CRT.

CAUTION

When you install the arc protection module on the CRT, make sure the socket aligns with the CRT pins. Press the socket firmly on the CRT, but take care not to bend the CRT pins.

3.6.1 Input Voltage Selection

Make sure you connect the plug-selectable jumper on the PS/M module to match the input voltage selected (110 V or 220 V). The jumper is factory-set for 220 V at connector J804. The 110 V jumper is at connector J803.

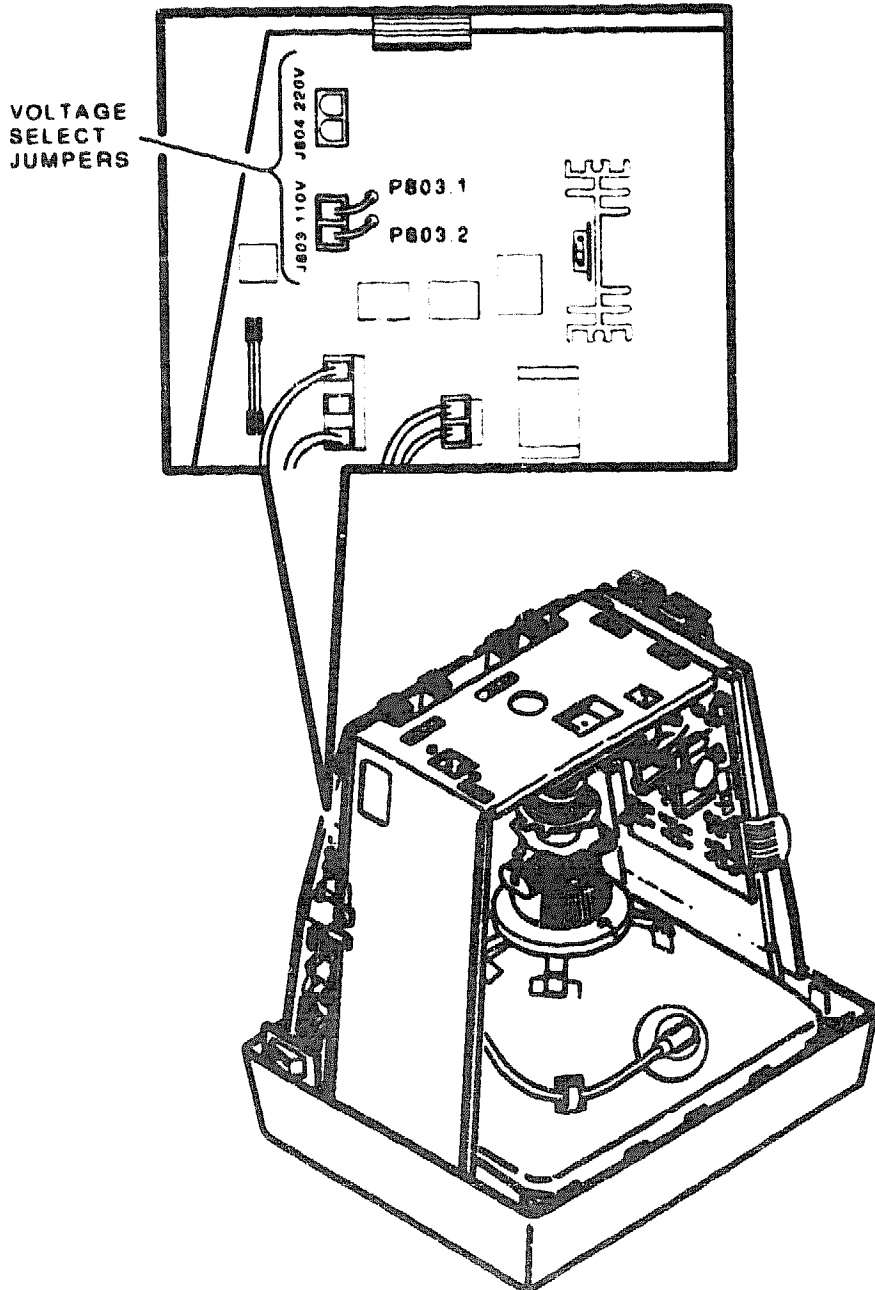

3.6.2 Service Switch

Make sure the service switch at S700 on the PS/M module is towards the (front) bezel. This setting puts the terminal in the operating state.

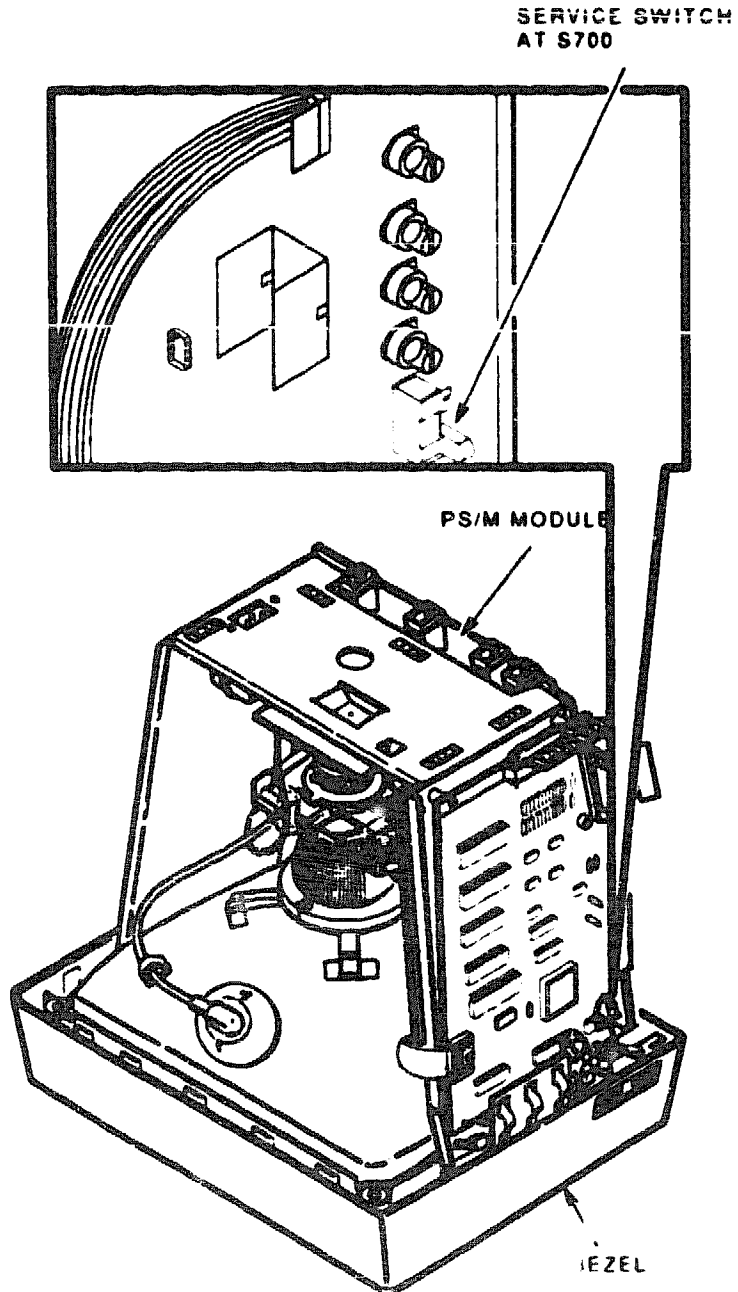

3.7 AC Inlet/Switch Assembly

First remove the following FRUs:

- Rear panel (Section 3.1)
- Rear enclosure/base assembly (Section 3.2)

To remove the AC inlet/switch assembly:

1. Remove the AC inlet/switch wires from the tie wraps inside the chassis.
2. Disconnect the 2-wire (power switch) cable from the PSM module connector J801.
3. Pull the switch up and out of the holder. Bring the switch inside the chassis.
4. Use the 3/8 inch nutdriver to remove the nut that holds the ground wire from the AC inlet filter to the chassis.
5. Hold the AC inlet filter while removing the two phillips screws on the rear chassis. Remove the filter and the switch.

NOTE

Do not discard the filter cover. It is not a FRU.

To install the AC inlet/switch assembly, reverse steps 1 through 5.

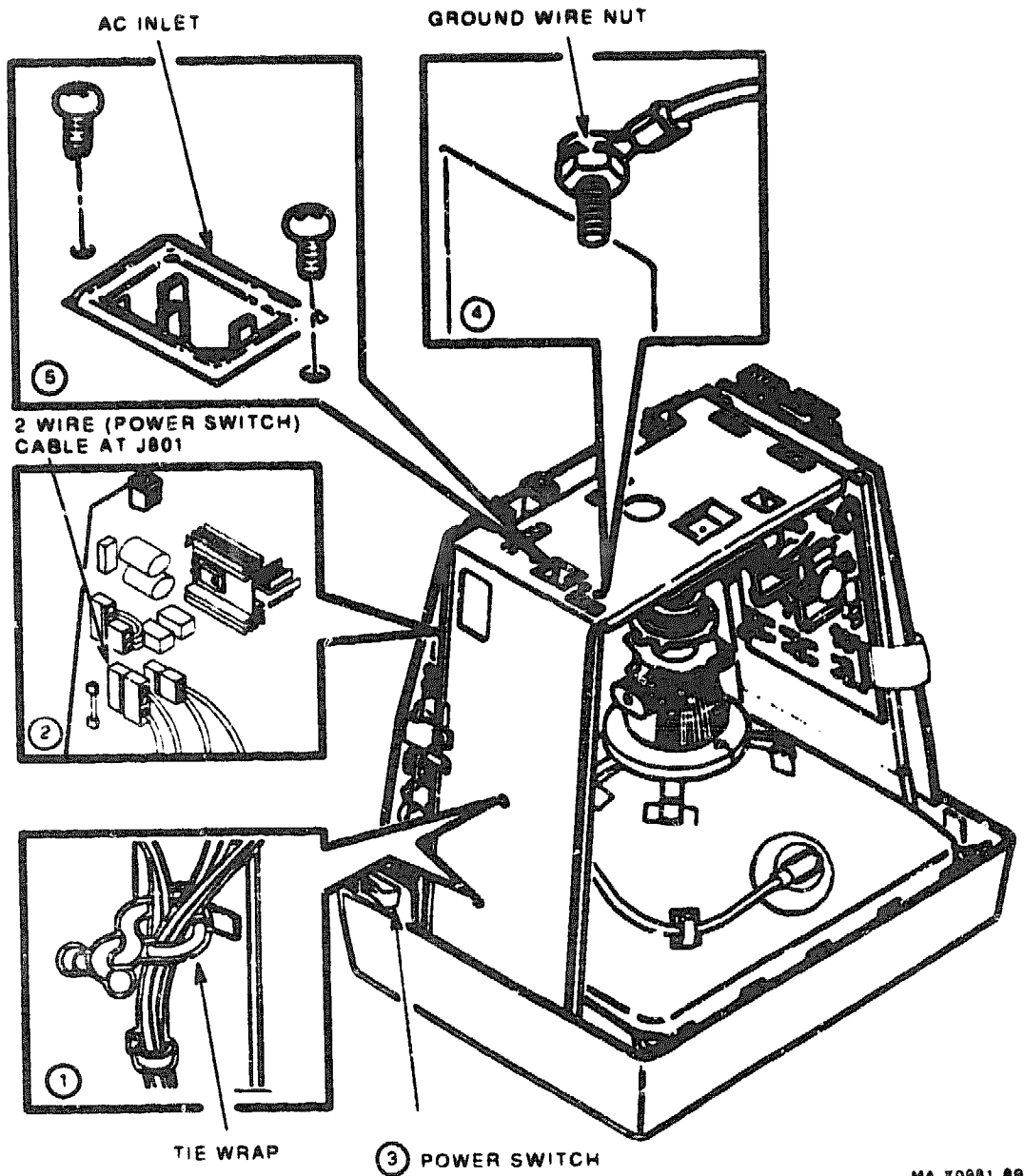

3.8 Control/Bracket Assembly (Brightness and Contrast)

To remove the control/bracket assembly:

1. Remove the rear panel (Section 3.1).
2. Remove the rear enclosure/base assembly (Section 3.2).
3. Disconnect the 6-wire (control/bracket) cable from the PS/M module connector J601 (locked).
4. Loosen the phillips screw that holds the control/bracket assembly to the chassis.
5. Lift the control/bracket assembly off the chassis.

To install the control/bracket assembly, reverse steps 1 through 5.

NOTE

When installing the control/bracket assembly, make sure the controls do not bind against the bezel.

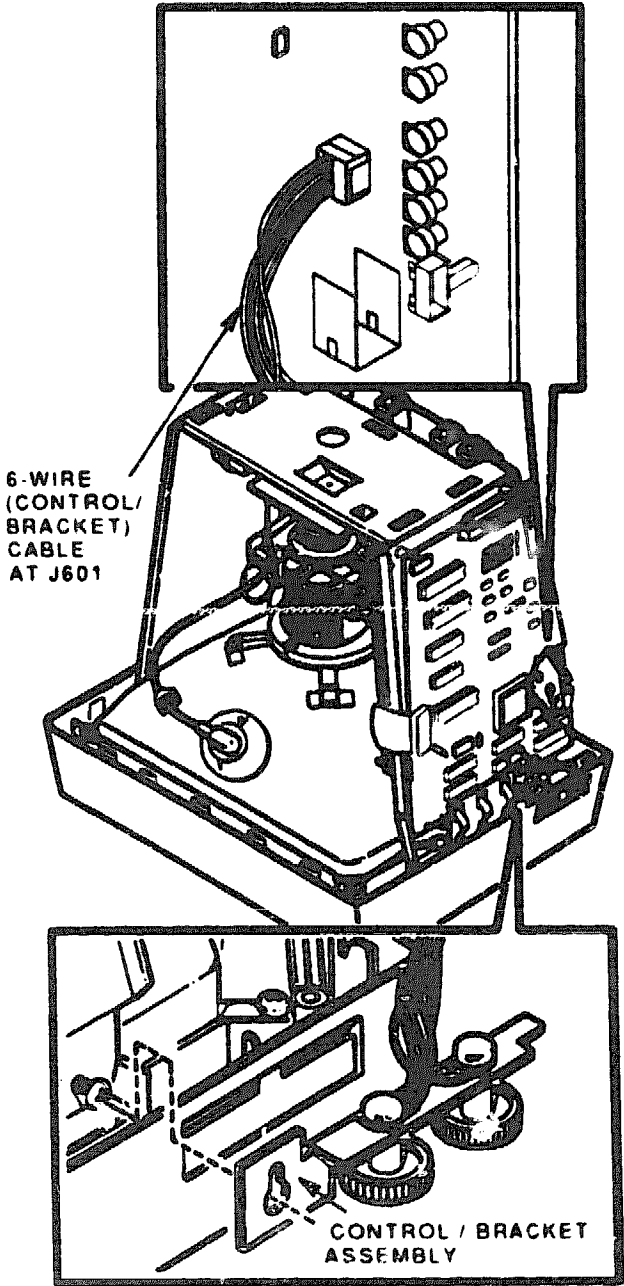

3.9 CRT/Bezel/Chassis Assembly

The CRT/bezel/chassis assembly is one FRU. The LED is part of this assembly. Do not try to remove or repair any part of this assembly in the field. To replace the assembly:

WARNING

You must discharge the CRT (Section 3.4) before removing any of the following FRUs.

1. Remove and save the rear panel (Section 3.1).
2. Remove and save the rear enclosure/base assembly (Section 3.2).
3. Remove and save the terminal control module (Section 3.3).
4. Remove and save the video amp module (Section 3.5).
5. Remove and save the PS/M module and arc protection module (Section 3.6).
6. Remove and save the AC inlet/switch assembly (Section 3.7).
7. Remove and save the control/bracket assembly (Section 3.8).
8. Now you can remove the CRT/bezel/chassis assembly.

To install the CRT/bezel/chassis assembly, perform steps 1 through 8 in the reverse order. To prepare the assembly for installation, place a piece of paper on a flat working surface. Carefully place the new monitor facedown on the paper. The paper prevents scratches to the monitor bezel.

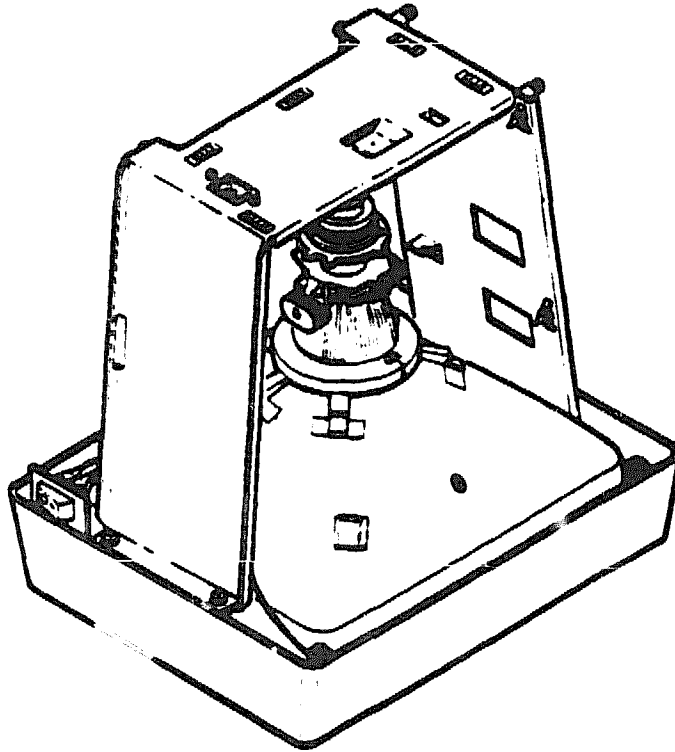

MA 10085 25

3.10 CRT Disposal

This section describes how to safely dispose of the terminal cathode ray tube (CRT).

WARNING

These steps should only be performed by trained Digital Customer Services Engineers only. This procedure is not intended for use by OEM and self-maintenance customers.

NOTE

This procedure supersedes all other tech tips about replacing and disposing of CRTs.

CRTs are glass vacuum tubes. Because air pressure outside the tube is greater than air pressure inside the tube, there is always the possibility of accidental implosion.

WARNING

You must handle CRTs very carefully to avoid accidental implosion and shattering glass.

To prevent personal injury from CRT implosion, use the following guidelines and disposal procedure to remove and dispose of a CRT. These guidelines and procedure are Digital field policy for all CRTs more than 3 inches in diameter.

Location

Work in areas where risks and exposure are limited to trained Digital personnel. Only Digital personnel should be in the area during CRT removal and replacement.

Protective Gear

Any person replacing a CRT must wear at least safety goggles (PN 29-16141-00) and the approved gloves (PN 29-16146-00).

WARNING

To avoid injury to the eyes or hands, always wear goggles and gloves when you work with a CRT.

Handling a CRT

- Never handle the CRT by the neck. Always use two hands and hold the CRT by the sides near its face.
- Keep the CRT away from your body during handling.
- Do not let the neck strike anything.
- Do not rest the CRT on its neck.
- Do not let the CRT touch any tools, such as screwdrivers and soldering irons.

Stocking and Storage

All CRTs must be kept in a closed container or mounted in the device cabinetry.

CRT Disposal

Use the following procedure to safely dispose of CRTs. Always perform this procedure at a Digital facility.

WARNING

Do not dispose of any CRT until it is rendered inoperative and safe to dispose.

Never perform the following disposal procedure at the customer site. Return the defective CRT to the local Digital facility for disposal.

At the Digital facility, you will need:

- An area clear of nonessential personnel
- A second person in the area in case of an emergency
- Safety goggles (PN 29-16141-00)
- Gloves (PN 29-14146-00)
- Pliers (PN 29-10311-00)

WARNING

Be careful when performing this procedure. For your safety, you must use the specified gloves and goggles.

Never handle pieces of phosphor-coated glass without wearing protective gloves.

1. Remove and save the rear panel (Section 3.1).
2. Remove and save the rear enclosure/base assembly (Section 3.2).
3. Remove and save the terminal control module (Section 3.3).
4. Remove and save the video amp module (Section 3.5).
5. Remove and save the PS/M module and arc protection module (Section 3.6).
6. Remove and save the AC inlet/switch assembly (Section 3.7).
7. Remove and save the control/bracket assembly (Section 3.8).
8. Remove the power switch assembly (Section 3.7).
9. Remove the four phillips screws that secure the chassis to the CRT/bezel.

3-32 Removing and Replacing FRUs

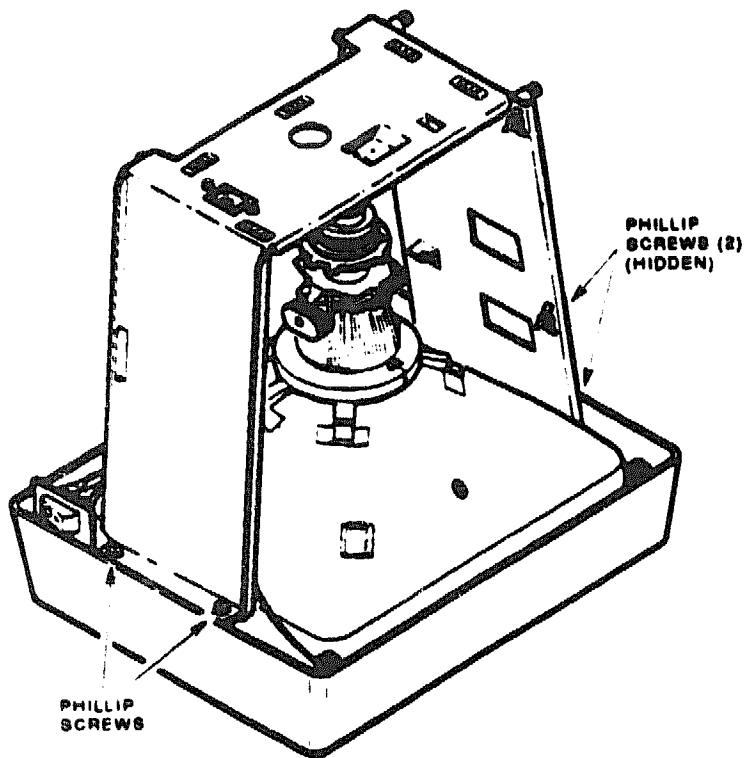

MA-21986-00

10. Remove the chassis.
11. Discard the chassis.
12. Place the old CRT and the original packing material in the container from which you removed the new CRT.
13. Seal up the container so that only the very tip of the CRT neck is exposed.
14. Using the specified pliers, slowly crush, but do not snap, the evacuation point. Do not move or disturb the CRT until the hissing sound of inrushing air has stopped.

NOTE

The evacuation point is a protrusion that extends from the circular area defined by the CRT neck pins. The glass

protrusion is sometimes encased in a protective plastic cap, and more force is required to crush it.

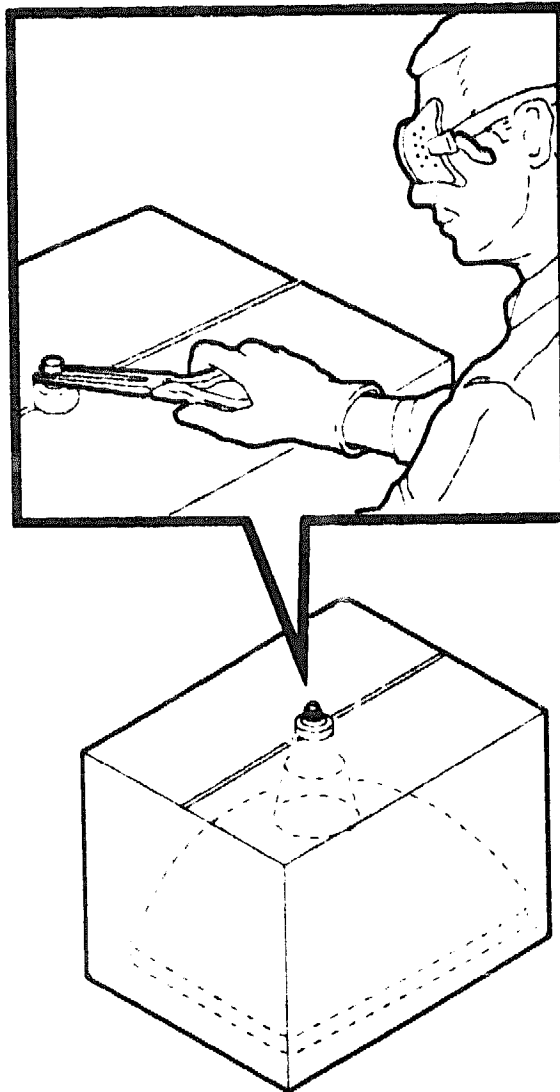

MA-X0007-00

15. Seal the carton with packing tape and dispose of it in the Digital site's trash compactor or receptacle.

NOTE

This safe "gassing" of the CRT is necessary to prevent liability and safety problems that may arise from accidental CRT implosion.

3.11 Keyboard

If the keyboard is faulty, replace the complete keyboard. To replace the keyboard:

1. Turn the terminal power switch off (0).
2. Disconnect the keyboard cable from the rear of the terminal.
3. Remove the old keyboard. If you have a US keyboard, go to step 5.

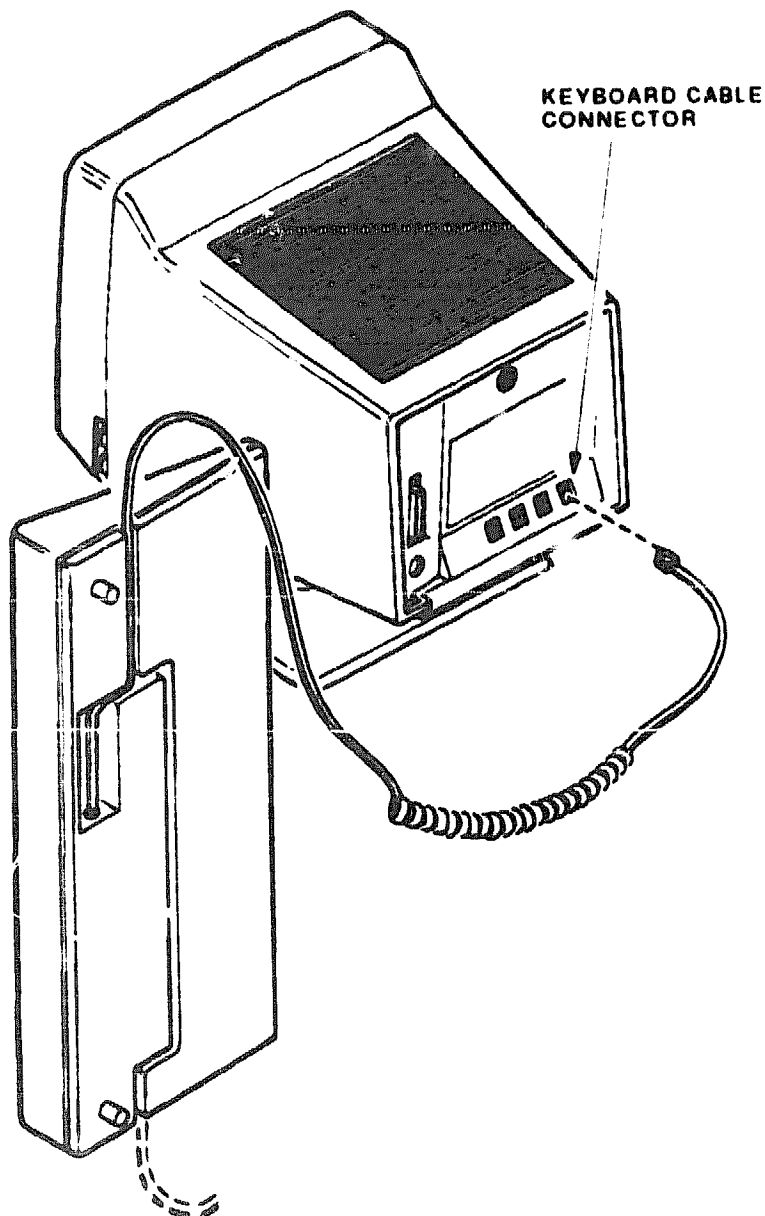

4. For non-U.S./U.K. keyboards only, do as follows:

Install the legend strip

To install the legend strip:

- a. Remove the legend strip from the old keyboard.
- b. Slide the legend strip under the tabs, so it fits over the legend strip already on the new keyboard.

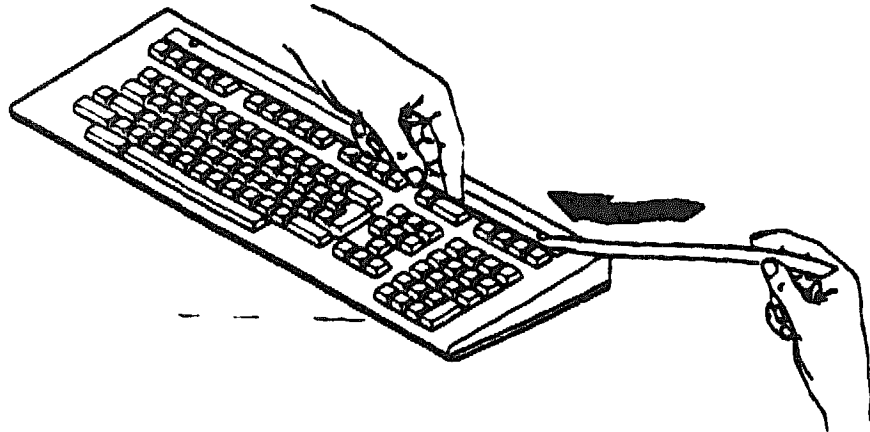

MA X0905 00

Install the local editing template.

To install the local editing template, place the template for the local editing keys around the editing and numeric keypads on the new keyboard.

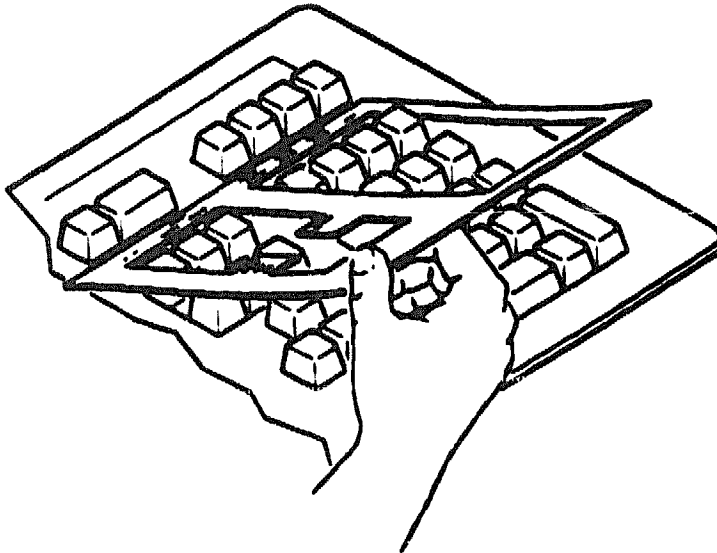

MA-X0896-80

5. Install the keyboard standoffs on the new keyboard.

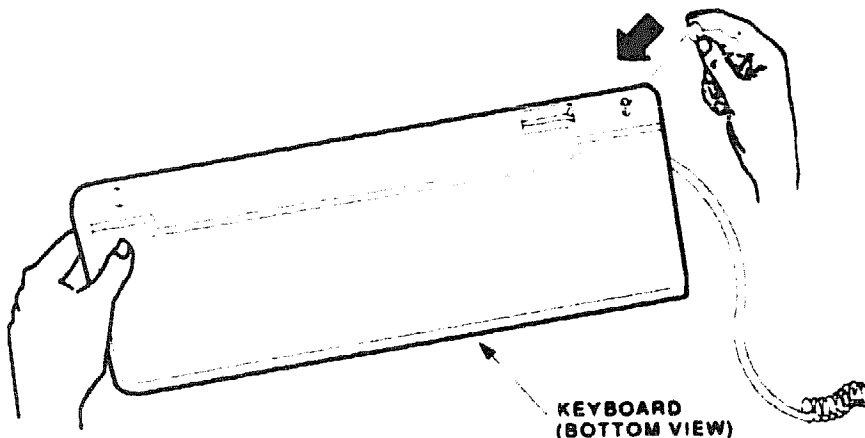

MA-X0807-80

6. Connect the new keyboard to the terminal as follows:

- a. Insert the long straight end of the keyboard cable into the connector on the bottom of the keyboard.

- b. Press the cable into the long or short groove.
Use the long groove if routing to the left. Use the short groove if routing to the right.
- c. Insert the other end of the cable into the keyboard connector on the rear of the terminal.

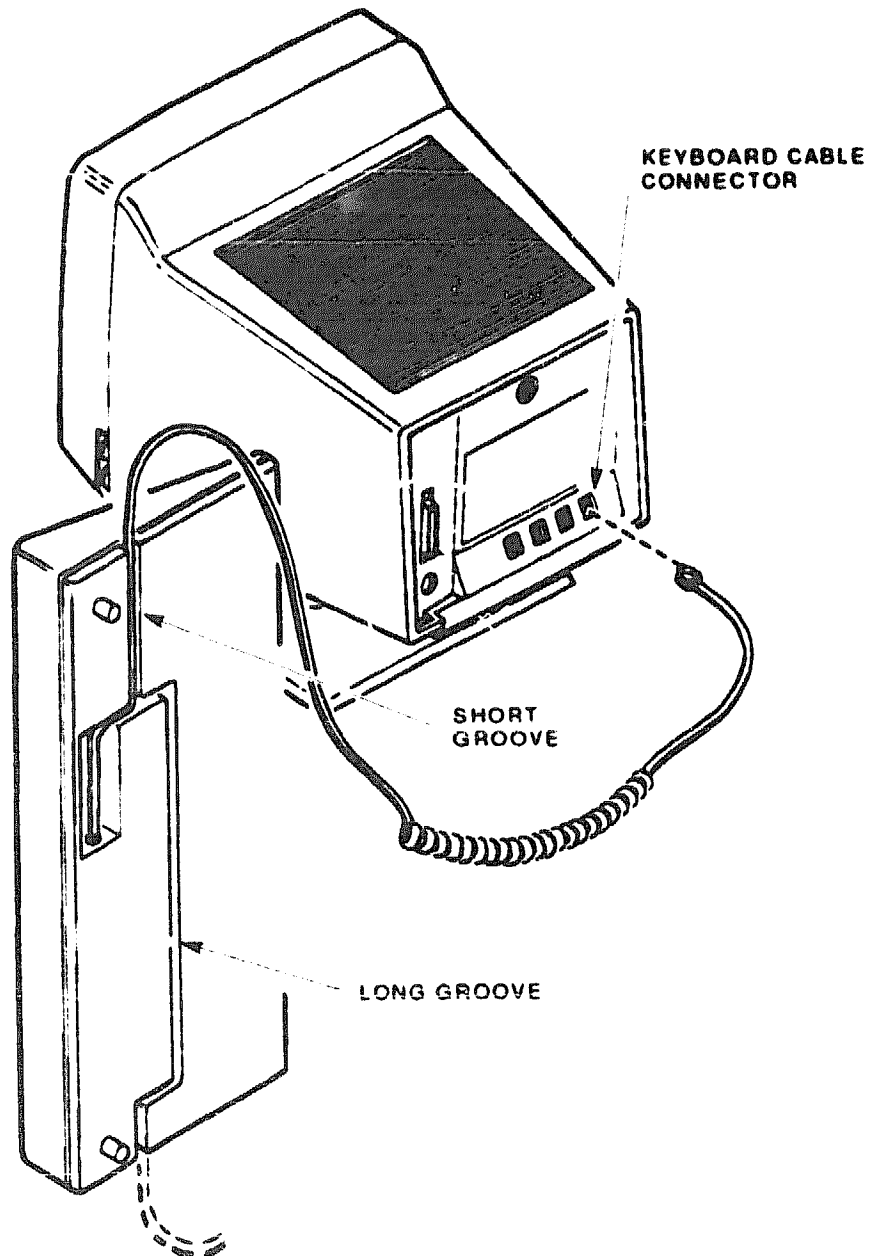

3.12 Mouse or Tablet (Options)

The VSXXX-AA mouse and VSXXX-AB graphics tablet are single FRUs (whole option swap). The cable for the mouse or tablet connects to the 7-pin locator device connector on the rear of the terminal.

To disconnect a mouse or tablet:

1. Remove the terminal rear panel (Section 3.1).
2. Disconnect the mouse or tablet cable from the terminal.

To install a new mouse or tablet:

1. Feed the cable through the opening in the rear panel.
2. Connect the cable to the 7-pin connector and install the rear panel.

NOTE

The cable for the mouse or tablet has a keying plug. Make sure you align the keying plug to the slot on the 7-pin connector.

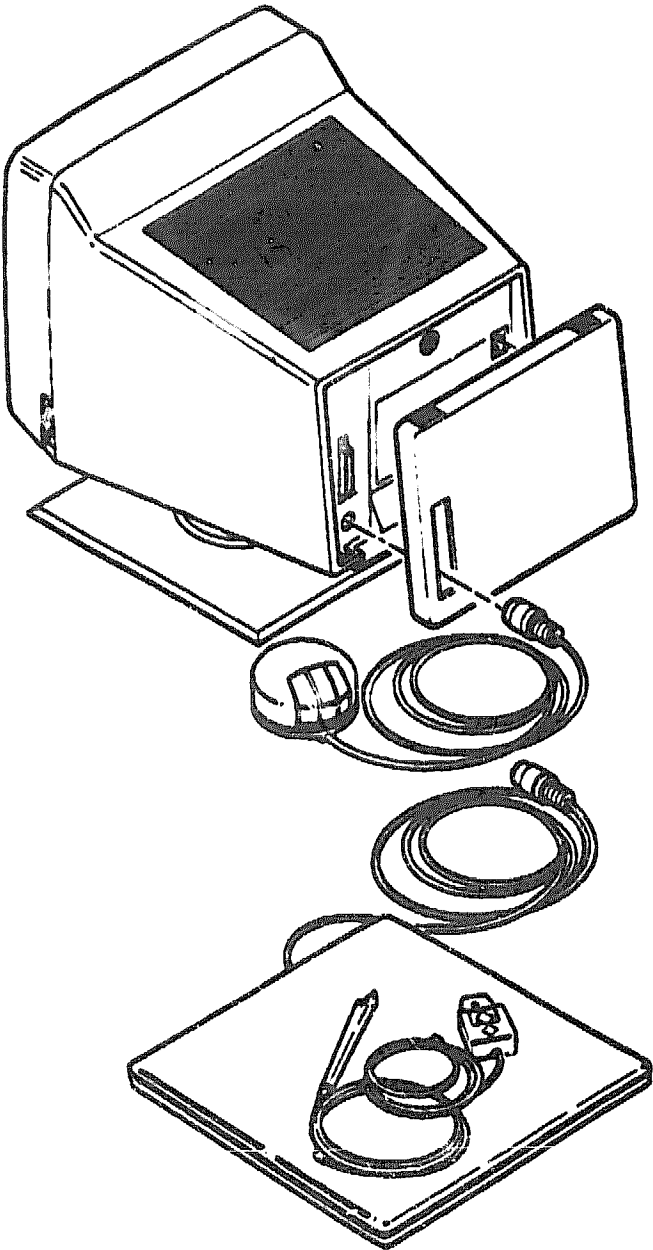

Aligning the Video Terminal

This chapter explains how to align the VT340+ Model G terminal.

4.1 General

When you need to do an adjustment, check all adjustments in the order shown, because many adjustments affect each other. You do not have to perform every adjustment each time you align the terminal. If a setting is already correct, you can skip that adjustment and go to the next one.

You must use the screen adjustment test patterns to make all adjustments. Use Section 4.2.1 to set up the terminal for adjustments.

Use a metric measuring tape (PN 29-25342-00) to measure the dimensions of the screen display. To avoid scratching the screen with the metal clip on the tape, start the measurement at 10 cm (100 mm). Make sure all adjustments are made under these conditions.

4.2 Video Terminal Adjustments

Figures 4-1 and 4-2 show the location of the controls used to make most adjustments. Table 4-1 lists the controls and their locations. The individual procedures describe the function of each control.

NOTE

Let the terminal warm up for at least 5 minutes before performing any adjustments on the power supply/monitor (PS/M) module.

Let the terminal warm up for at least 20 minutes before performing any adjustments (color bias and drive controls) on the video amp module.

4-2 Aligning the Video Terminal

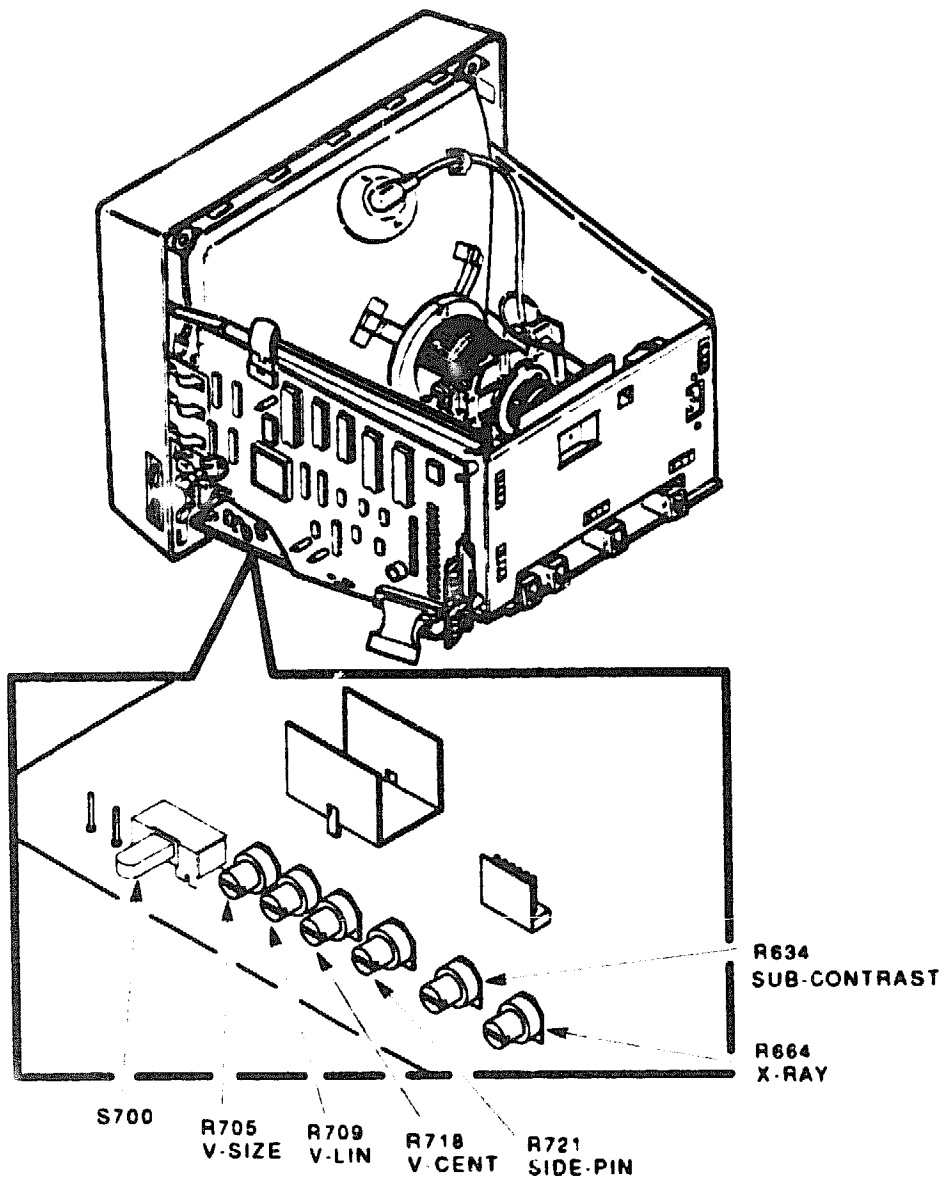
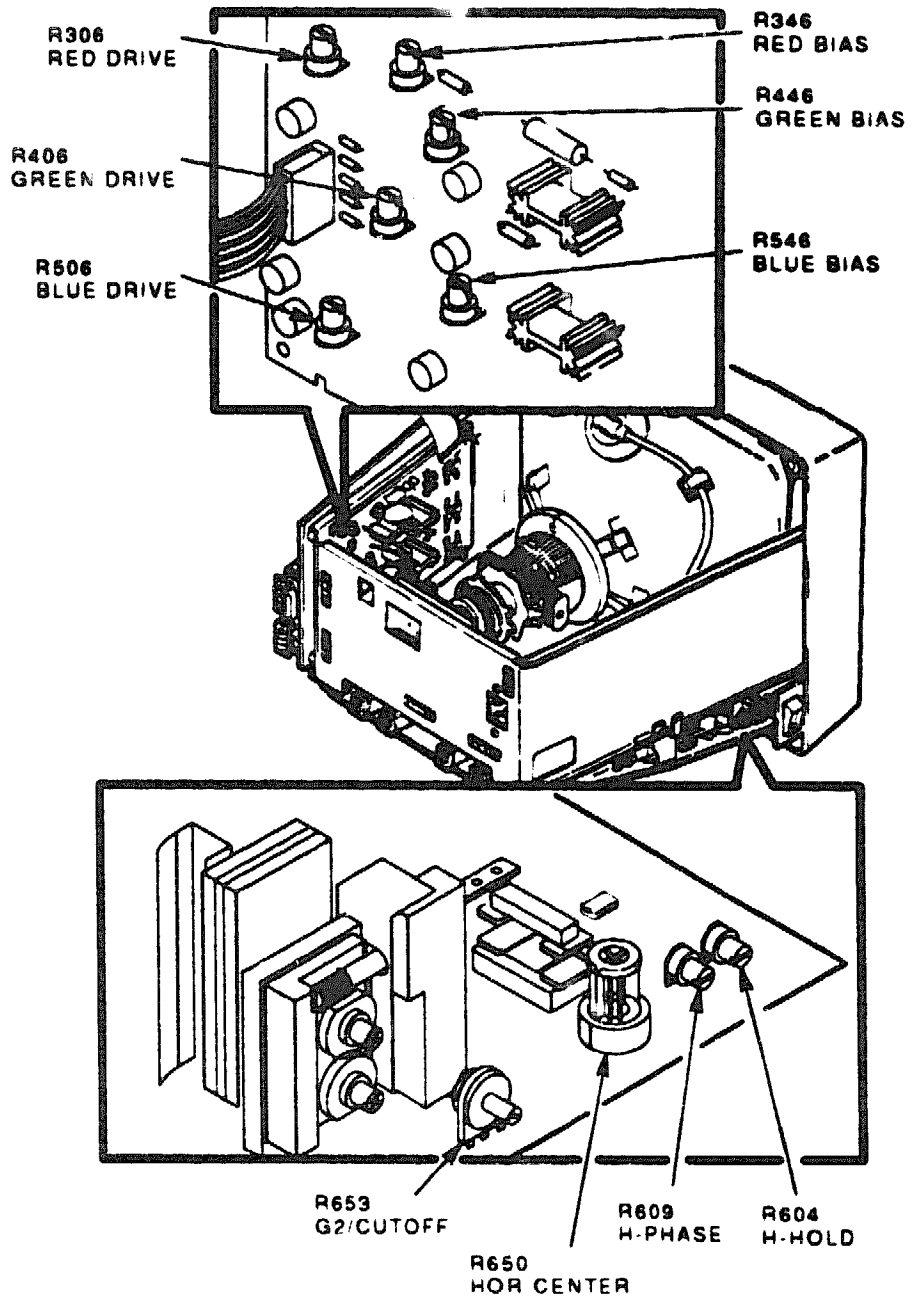

Figure 4-1 Video Adjustment Controls (1 of 2)



MA X0987 89

Figure 4-2 Video Adjustment Controls (2 of 2)

4-4 Aligning the Video Terminal

Table 4-1 lists the adjustment controls and their locations.

Table 4-1 Adjustment Controls

PS/M Module (From Bezel to Rear of Chassis)			
Left Side		Right Side	
L602	H-WIDTH (Horizontal Width)	S700	Service switch
R604	H-HOLD (Horizontal Hold)	R705	V-SIZE (Vertical size)
R609	H-PHASE (Horizontal Phase)	R709	V-LIN (Vertical linearity)
R650	HOR CENTER (Horizontal Center)	R718	V-CENT (Vertical centering)
R653	G2/Cutoff (screen)	R721	SIDE-PIN (Rectangularity)
		R634	SUB-CONTRAST
		R664	HV-PROT (HV Protector)

Video Amp Module (At Rear of Chassis)			
R306	Red drive	R346	Red bias
R406	Green drive	R446	Green bias
R506	Blue drive	R546	Blue bias

NOTE

Do not adjust the R664 (HV-PROT) control unless the P/M module has been repaired. The R664 control was fixed at the factory.

4.2.1 Before You Start

Before you perform the adjustment:

1. Remove the rear panel (Section 3.1).
2. Remove the rear enclosure/base assembly (Section 3.2).
3. Place the terminal on a nonconductive surface.
4. Reconnect the keyboard cable and power cord.
5. Turn the power switch on (1). Wait for the "VT340+ OK" message to appear on the screen.

6. Let the terminal warm up for at least 20 minutes before you start the adjustment procedures.

4.2.2 Setting Cutoff

Cutoff is the point of operation in a CRT tube where current does not flow. To set the cutoff:

1. Set the brightness control and the contrast control to maximum.
2. Turn the R653(G2) control on the PS/M module counterclockwise until it stops (minimum setting).
3. Turn the R346 (R-Bias), R446 (G-Bias), and R546 (B-Bias) controls to their midrange positions.
4. If the CRT is in good condition, set the R406 (G-Drive) control on the video amp module to midrange. If the CRT is degraded, set the R406 control completely counterclockwise to get more luminance.

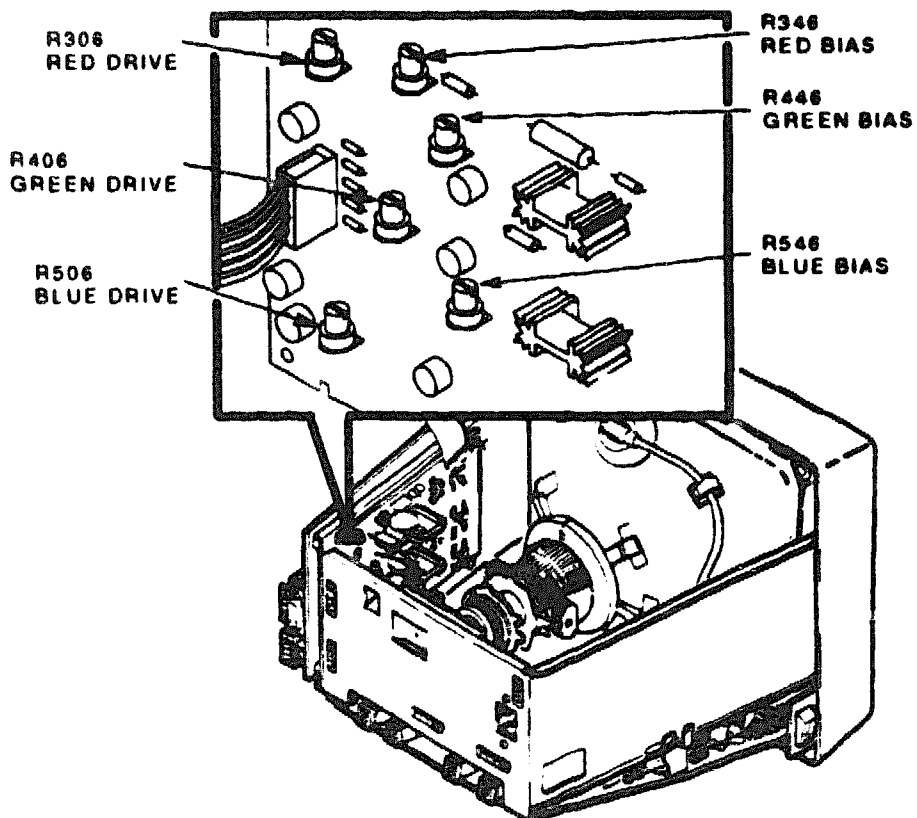

4-6 Aligning the Video Terminal

5. Set the service switch at S700 on the PS/M module to the rear of the chassis.

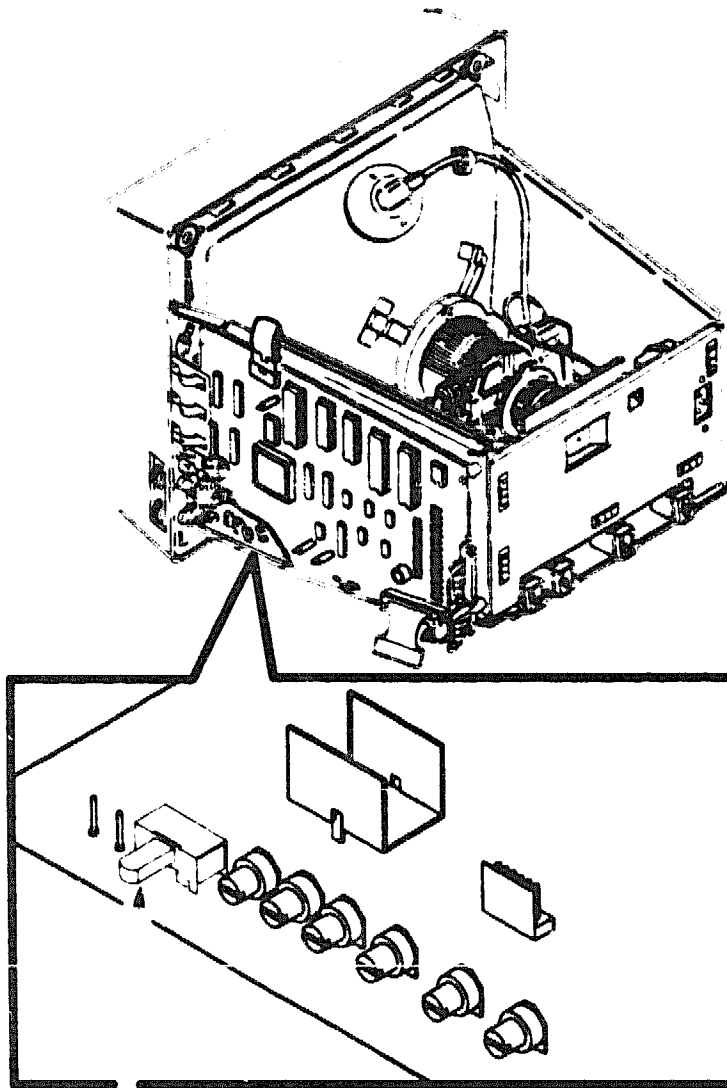

S700

MA-X0116-90

6. Slowly turn the R653 (G2) control clockwise, until you see a horizontal line on the screen. Note the line color (red, green, or blue), then make the line dim, then go to the next step.

CAUTION

Whenever the horizontal line appears, make it dim. Failure to do so may burn the phosphor on the CRT.

7. Slowly turn the R653 (G2) control counterclockwise *until the line just disappears*. Do not turn the control too far.

The cutoff point for the colored line that was on the screen is now set. Do not adjust the cutoff (bias) control for that color during the rest of this procedure.

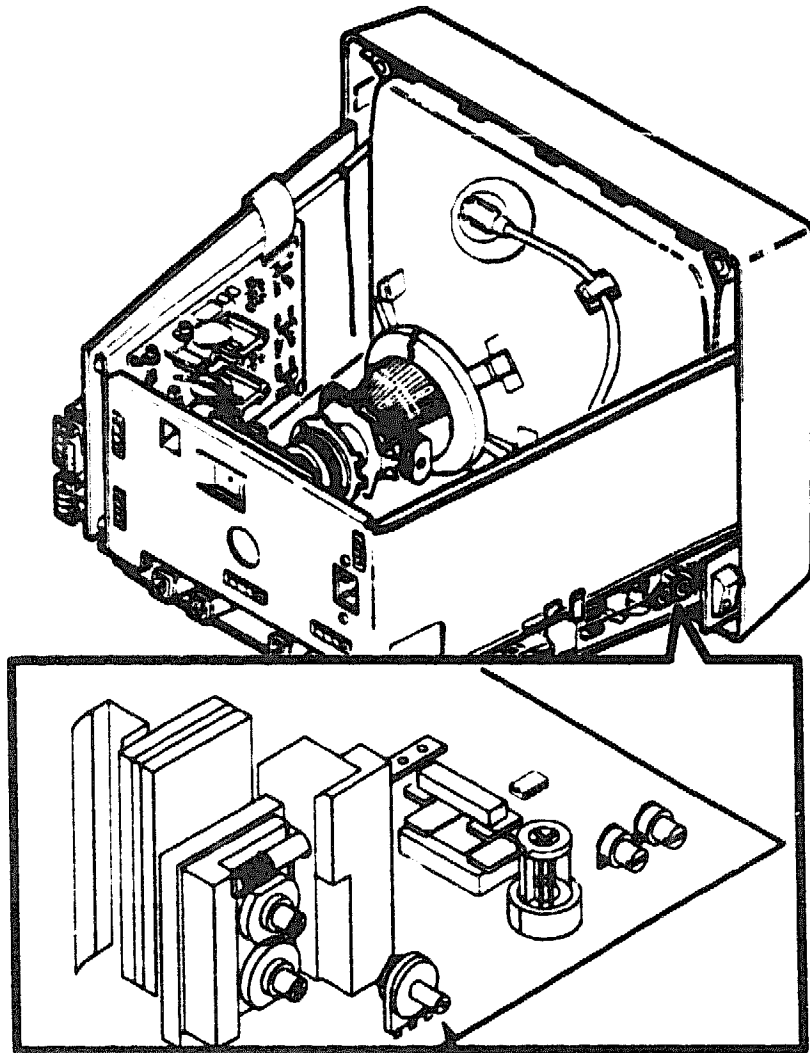

R653
G2/CUTOFF

NOTE

When you set the bias controls for the other two colors, make sure the horizontal line just disappears. It is important to set all three bias controls so that the three colors disappear at the same point (intensity).

8. Turn the bias control for one of the two other colors, until you see a line of that color on the screen. Then turn the control back, until the line just disappears.

Red Bias - R346 Green Bias - R446 Blue Bias - R546

9. Repeat the previous step for the third color.
10. Slowly turn the R653(G2) control until the line just appears. If the line is not white, turn one of the last two bias controls you adjusted until the line becomes white.

NOTE

Do not turn the bias control for the color you adjusted.

11. Set the service switch at S700 on the PS/M module to the (front) bezel.
12. You need a radiance meter for the next step. Refer to Section 4.2.3 to prepare the meter.
13. Place the occluder in the arc on the screen and adjust the R653(G2) control until the raster (white lines) luminance is approximately 0.005 (0.5 foot lamberts).
14. Turn the brightness control until the raster just appears. Then turn the control back, until the raster just disappears.

NOTE

Any data now displayed on the screen will be white.

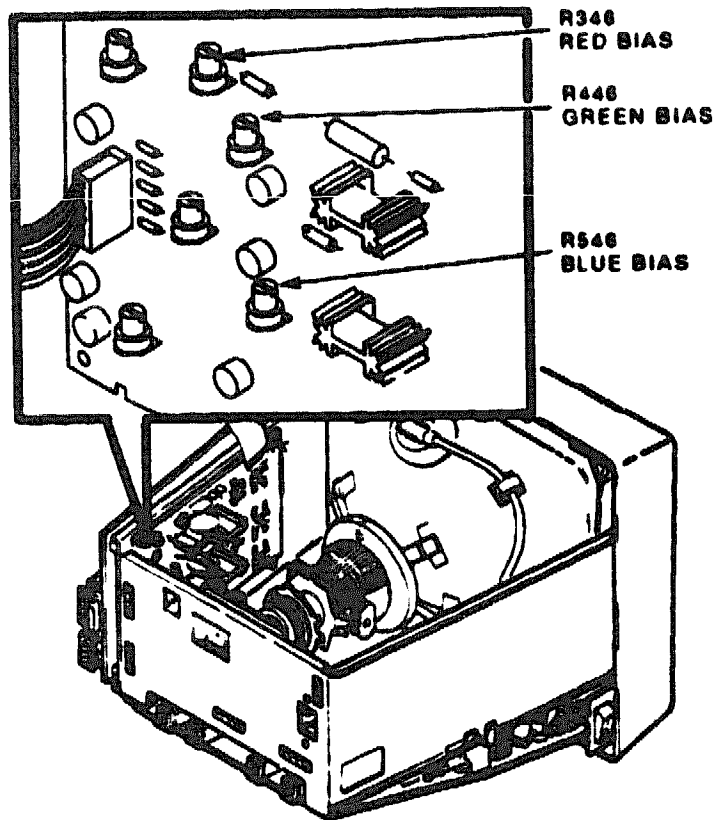

MA X0118-90

4.2.3 Radiance Meter

You need the radiance meter supplied with the color video service kit (PN A2-S0099-01). The kit comes with a manual that contains important information on using the meter. You should read this manual before using the meter.

4-10 Aligning the Video Terminal

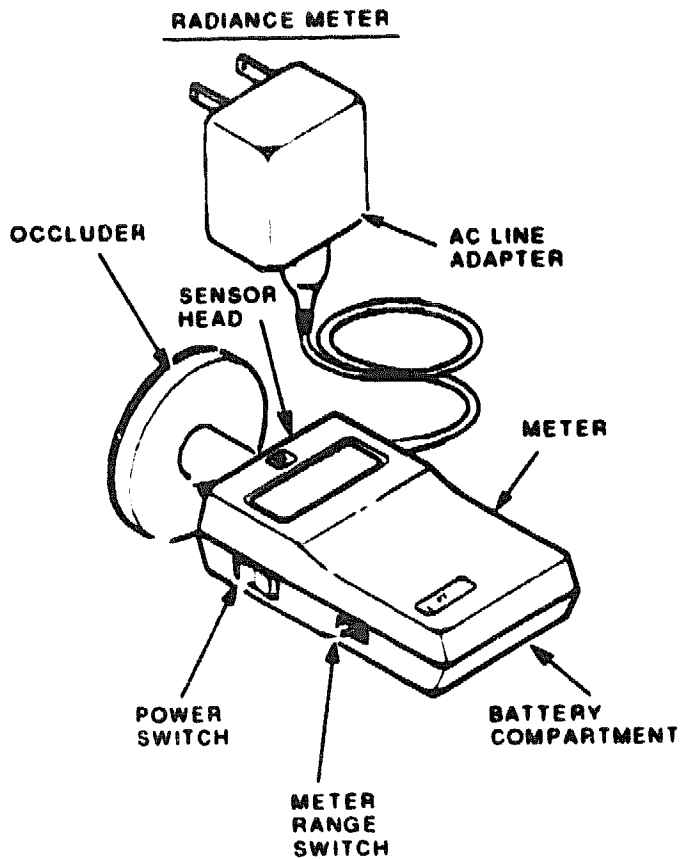

MA X0991 89

Prepare the meter for use by removing the cap and attaching the occluder assembly.

CAUTION

Do not touch the filter while the cap is removed. Do not tighten the occluder too far.

The meter's power switch has three positions. Set the power switch to the down position.

- | | |
|--------|-------------------------------|
| Down | Power on, without a backlight |
| Center | Power off |
| Up | Power on, with a backlight |

Use the meter range switch to select the accuracy of the meter's decimal readout. Set the switch to the second position from top of the meter (1.999).

Place the occluder firmly against the center of the screen. Take a china pencil and draw an arc on the screen around the occluder.

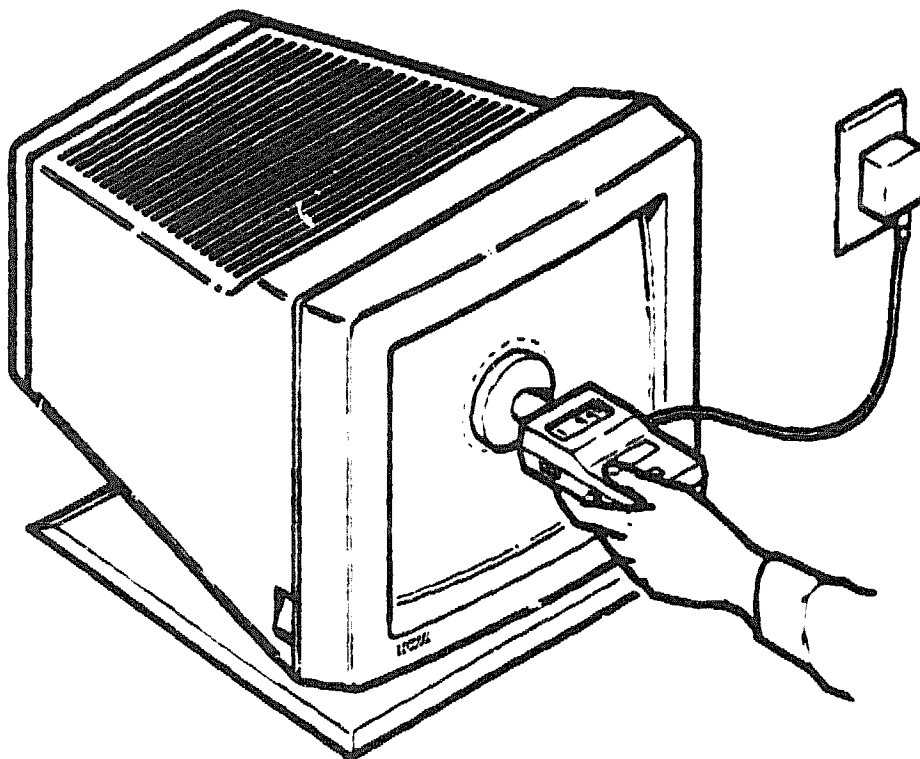

MA-X0902-89

NOTE

You must take all meter readings with the occluder centered in the arc you drew on the screen.

4.2.4 Displaying Screen Tests

To display the test patterns, use the Diagnostic Set-Up screen (Section 2.4).

1. Press the **Set-Up** key to enter set-up. The Set-Up Directory appears on the screen.
2. Use the arrow keys to select the **Diagnostics Set-Up** field. Press the **Enter** key to display the Diagnostic Set-Up screen.
3. Use the arrow keys to select **Run Screen Tests**.

4. Press the **Enter** key to run the screen tests. The terminal displays a series of test patterns repeatedly.
 - To keep a test pattern on the screen, press the **Hold Session** key when the pattern appears.
 - To select a pattern at random, press one of the following keys on the numeric keypad and the **Hold Screen** key. If you want to use this method to display screen test patterns, do not press the **Hold Screen** key until you want to display the series of test patterns repeatedly.

9 = red screen	2 = red crosshatch
PF1 = green screen	5 = purple crosshatch
PF2 = blue screen	6 = blue crosshatch
0 = white screen	7 = green crosshatch
	8 = blue crosshatch
PF3 = red scale	1 = screen of Es
PF4 = green scale	3 = color bars
. = blue scale	4 = screen of dots in squares
. = white scale	Enter = Diagnostic Set-Up screen
. = gray scale	

4.2.5 Color Gain

- 1 Run the screen test (Section 4.2.4).
2. Select the green screen by pressing the **PF1** key or stop the screen test with the **Hold Session** key when the green screen appears.
3. Make sure the contrast control is set to maximum and the brightness control is set so the raster just disappears.

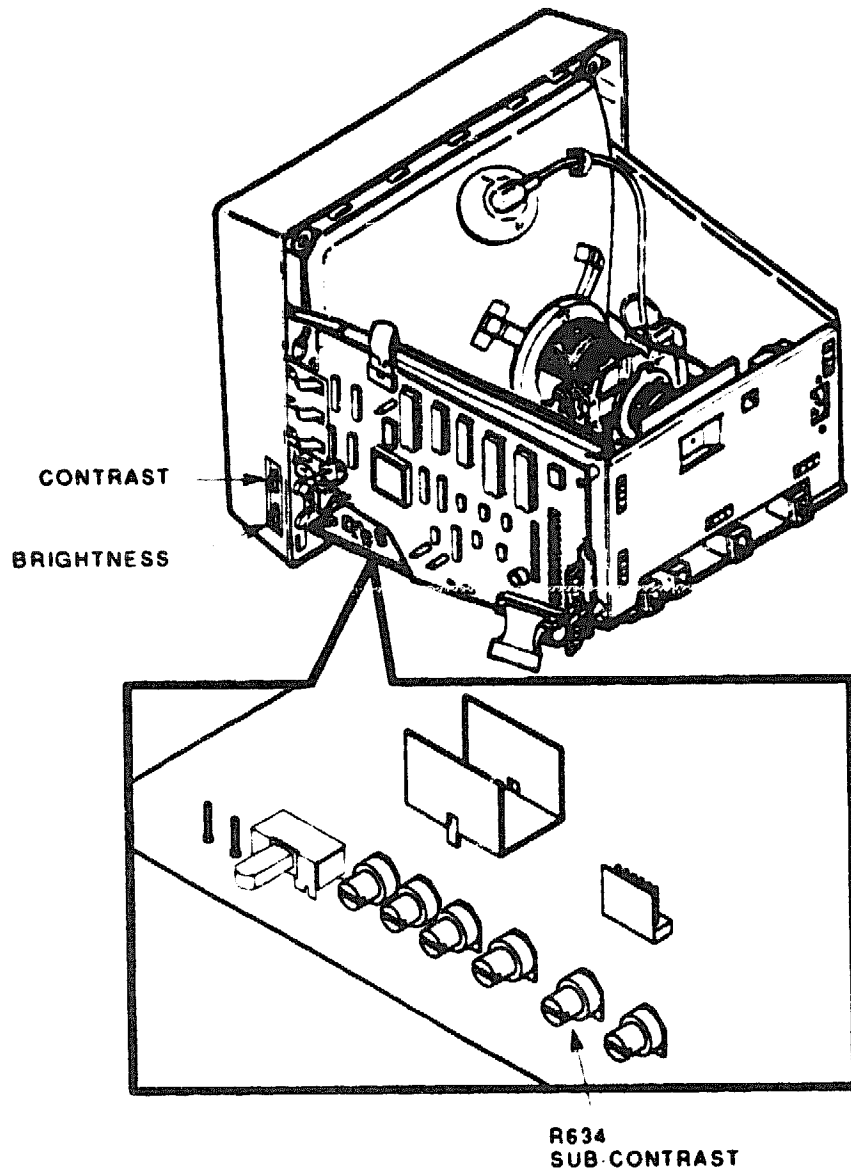

MA 20119 00

4. Place the occluder in the arc on the screen and adjust the R634 (SUB-CONTRAST) control on the PSM module until the meter reads 0.080.
5. Select the red screen by pressing the key or stop the screen test with the key when the red screen appears.

4-14 Aligning the Video Terminal

6. Place the occluder in the arc on the screen and adjust the R306 (R-Drive) control on the video amp module until the meter reads 0.056.
7. Select the blue screen by pressing the **PF2** key or stop the screen test with the **Hold Session** key when the blue screen appears.
8. Place the occluder in the arc on the screen and adjust the R506 (B-Drive) control on the video amp module until the meter reads 0.070.
9. Select the white screen by pressing the **Q** key or stop the screen test with the **Hold Session** key when the white screen appears.
10. Adjust the contrast control to minimum.
11. Adjust the R634(SUB-CONTRAST) control until the meter reads 0.003 (0.3 foot lamberts).

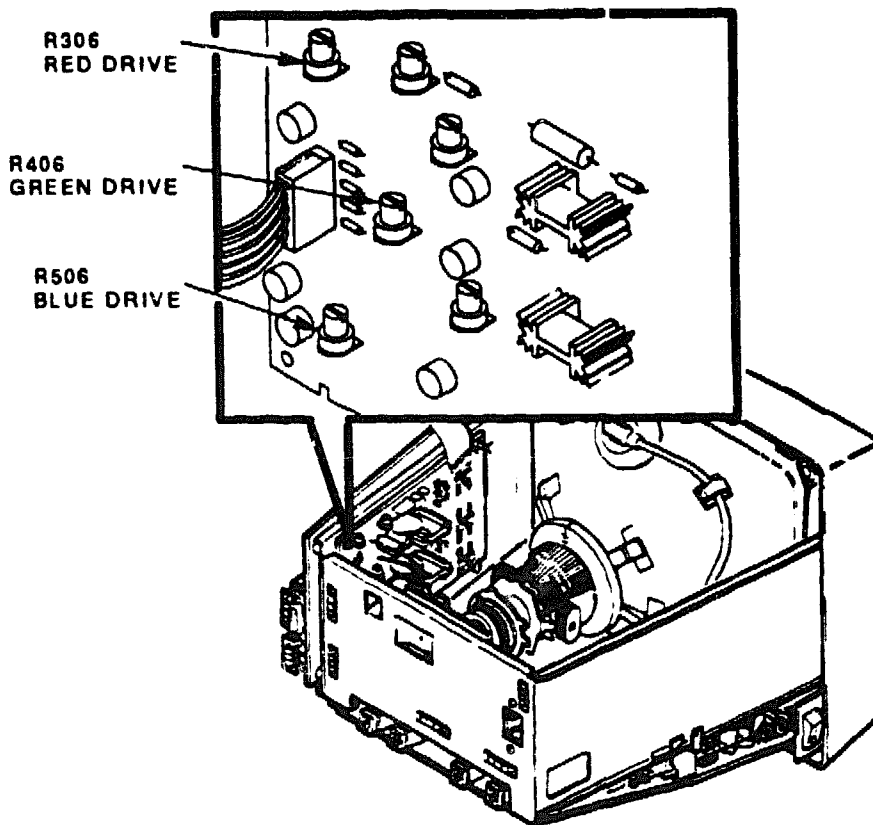

4.2.6 Display Size

This section describes how to check and adjust horizontal centering, horizontal phase, rectangularity, vertical centering, horizontal width, and vertical height. To perform these adjustments:

1. Run the screen test (Section 4.2.4).
2. Select the screen of Es by pressing the **1** key or stop the screen test with the **Hold Session** key when the screen of Es appears.

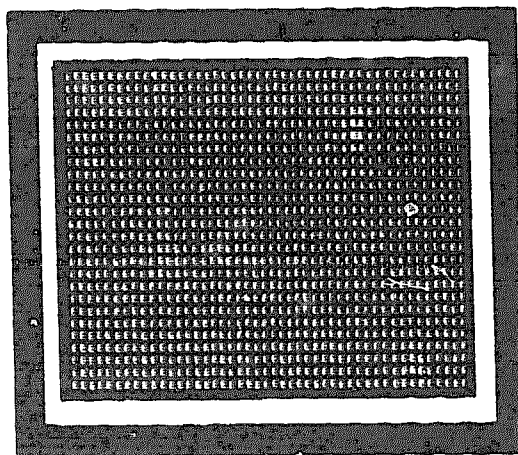
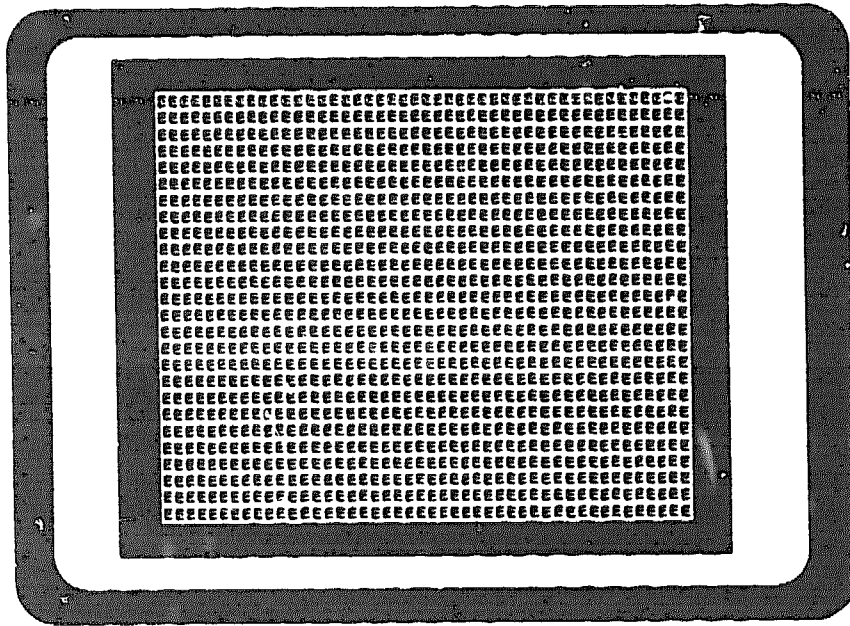

4.2.6.1 Horizontal Centering

To check and adjust the horizontal centering:

1. Set the brightness control to maximum and the contrast control to minimum.
2. Check the screen of Es to see if the raster is centered.
3. If necessary, adjust the R650 (HOR CENTER) control to center the raster.

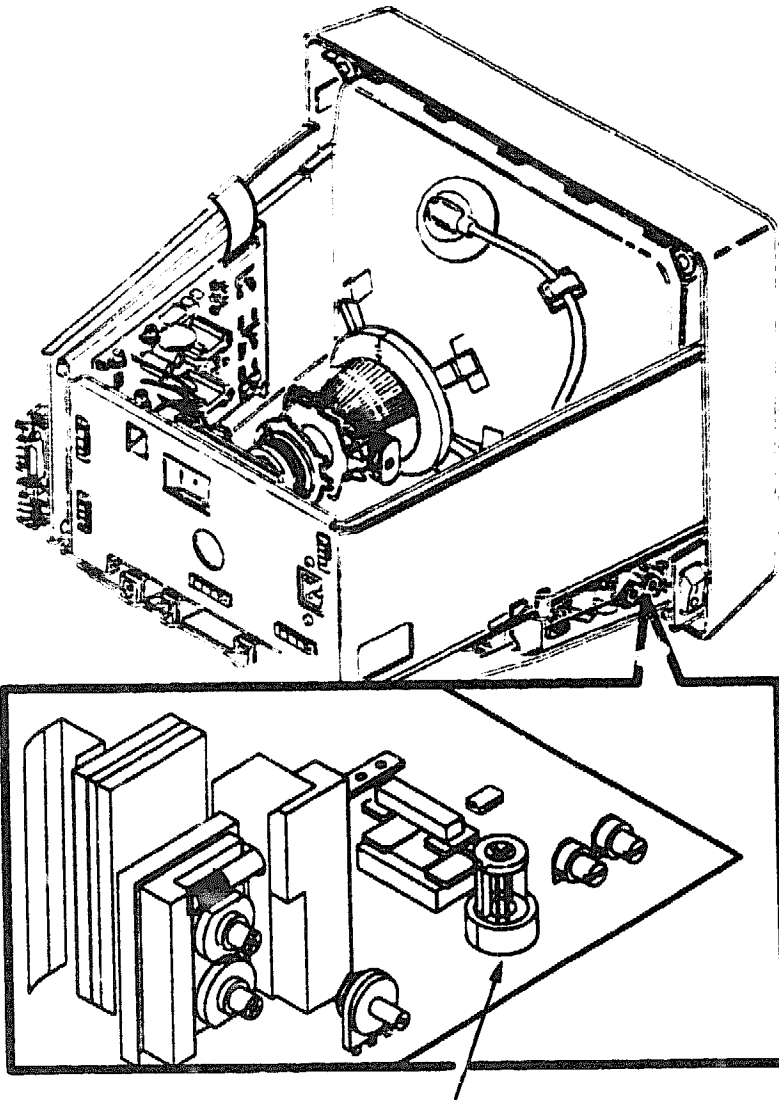

R650
HOR CENTER

MA-X0126-00

4.2.6.2 Horizontal Phase

To check and adjust the horizontal phase:

1. Adjust the brightness control until the raster appears around the screen of Es with a white border.
2. Adjust the R609 (H-PHASE) control until the display appears centered in the raster.

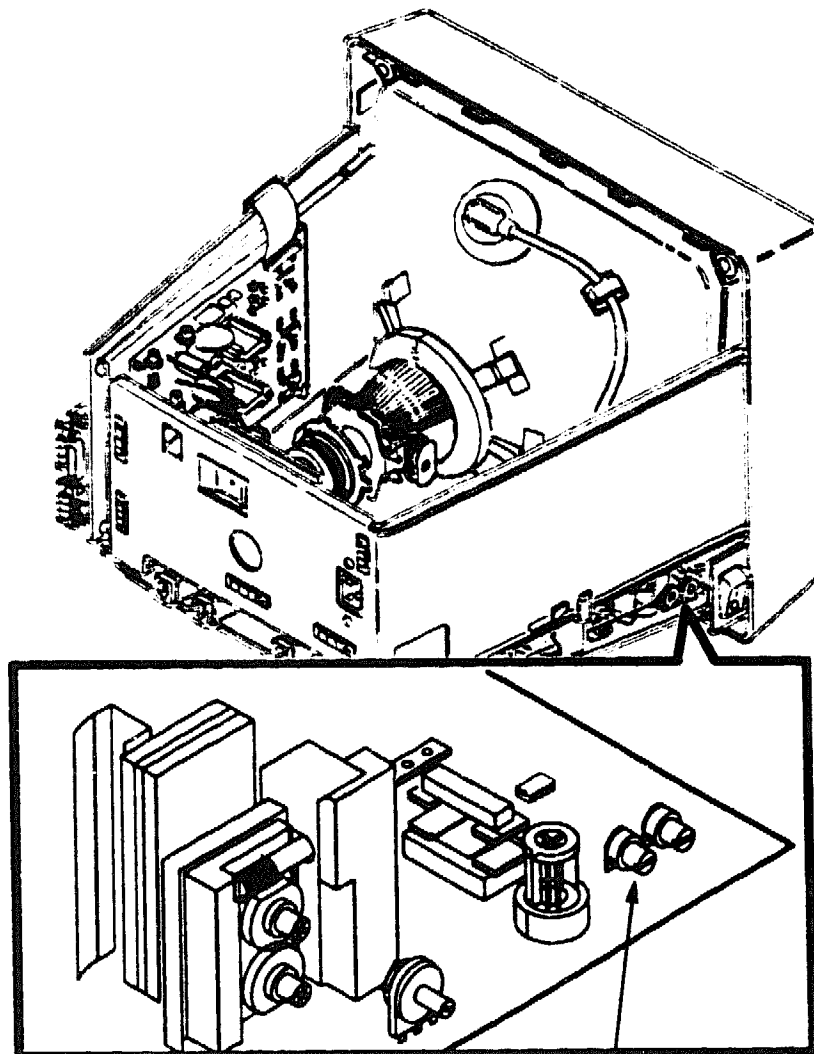

R609
H-PHASE

4.2.6.3 Rectangularity

This procedure ensures that the sides of the video display are straight, not curved. The curved line effect is known as *pin-cushioning* (when the lines curve in) or *barreling* (when the lines curve out).

1. Make sure the sides of the screen of Es are straight.
2. Adjust the R721 (SIDE-PIN) control until the sides appear straight.

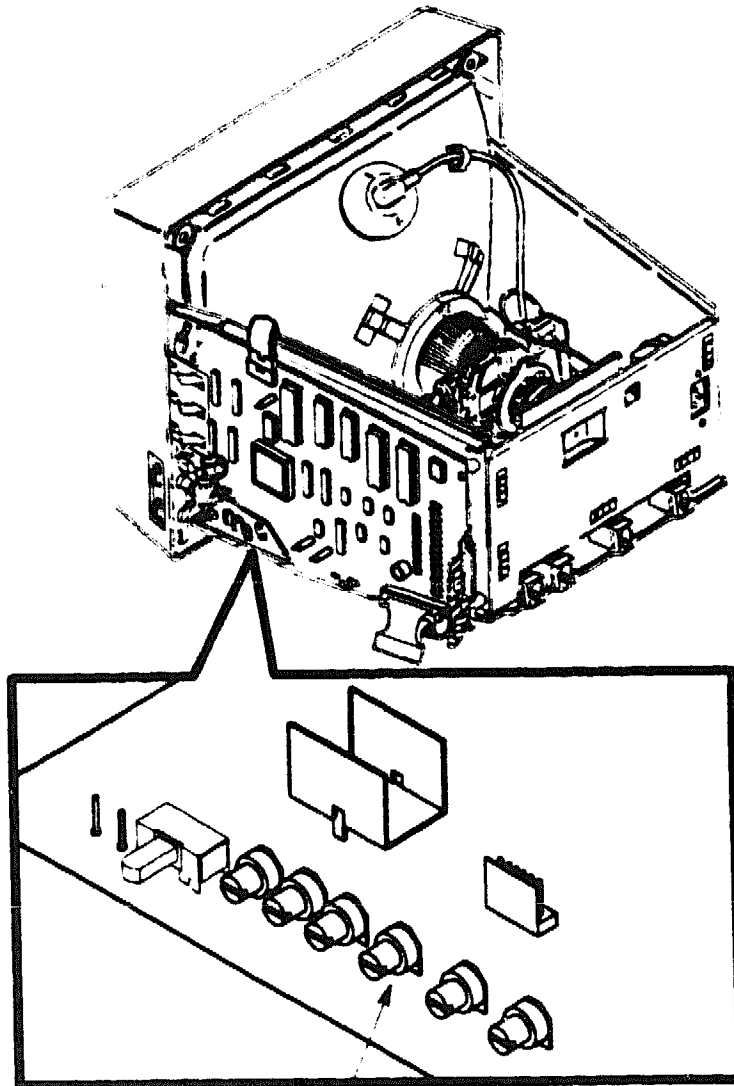

R721
SIDE-PIN

4.2.6.4 Vertical Centering

To check and adjust the vertical centering:

1. Make sure the screen of Es appear vertically centered on the screen.
2. If necessary, adjust the R718 (V-CENT) control until the Es appear centered.

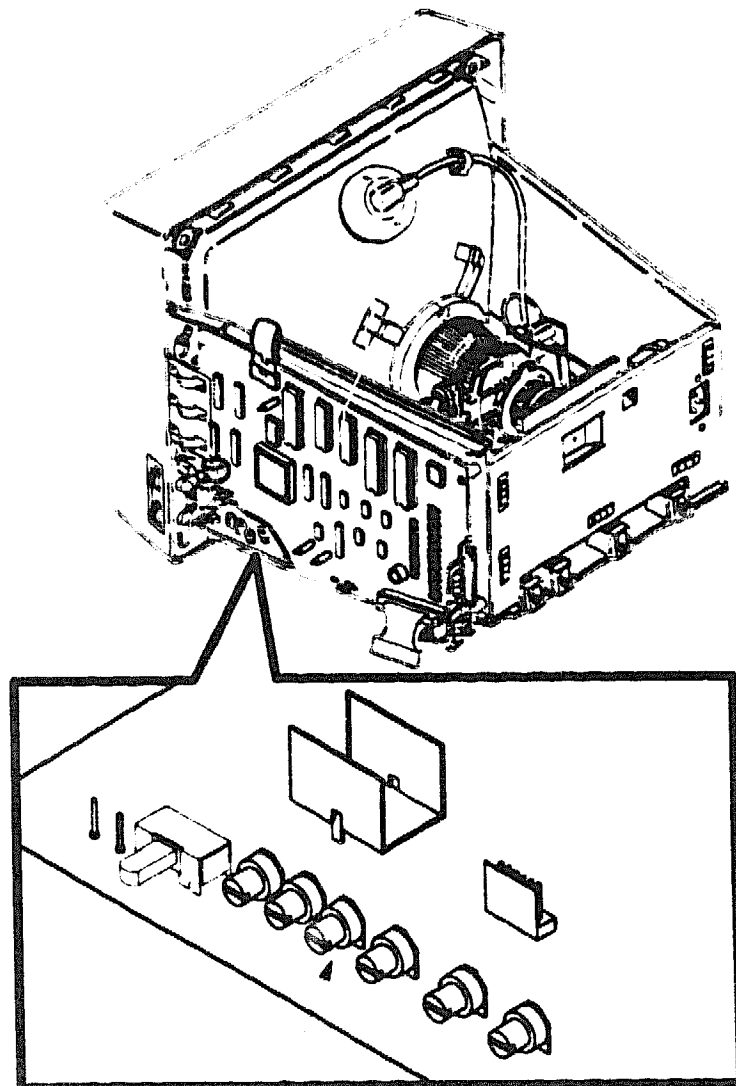

R718
V-CENT

4.2.6.5 Horizontal Width and Vertical Height

To check and adjust the horizontal width and vertical height:

NOTES

In the following steps, use a metric measuring tape (PN 29-25342-00) to measure the dimensions of the screen display. To avoid scratching the screen with the tape's metal clip, start the measurements at 10 cm (100 mm).

In the following figure, the screen of Es is removed for clarity.

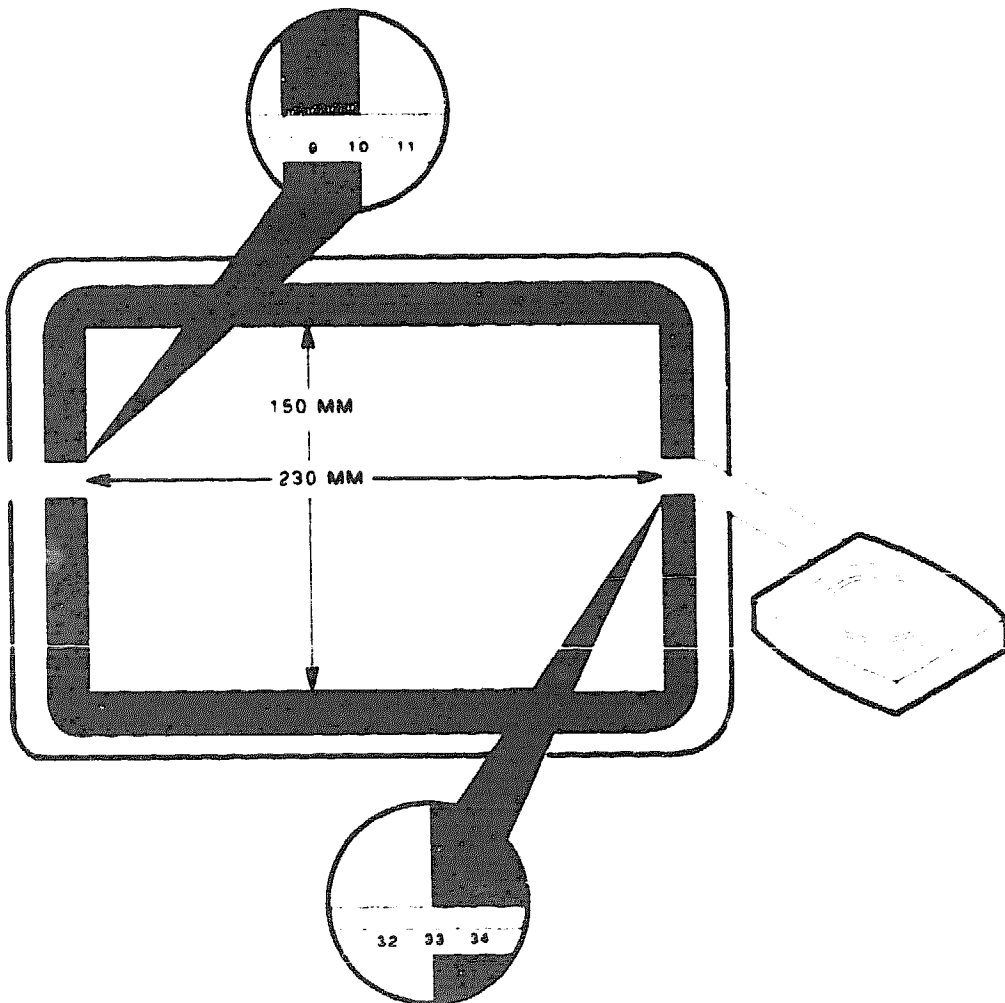

1. Measure and check the outside edges of the screen of Es for a horizontal width of about 240 mm (± 2.0 mm).
2. If necessary, adjust the display width to 240 mm by using the R650 (HOR CENTER) control.

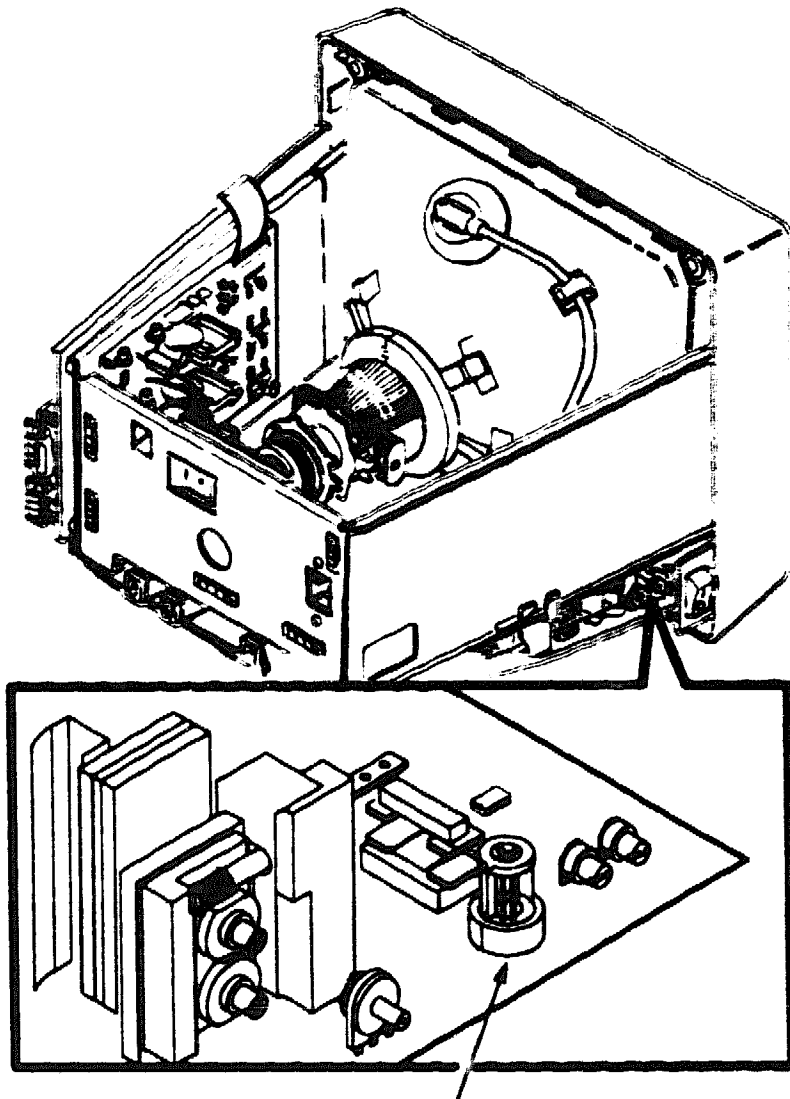

R650
HOR CENTER

MA-X0126 90

3. Check the screen of Es for a vertical height of about 156 mm (± 2.0 mm).

4-22 Aligning the Video Terminal

4. If necessary, adjust the R705 (V-SIZE) control until the display height is 156 mm.

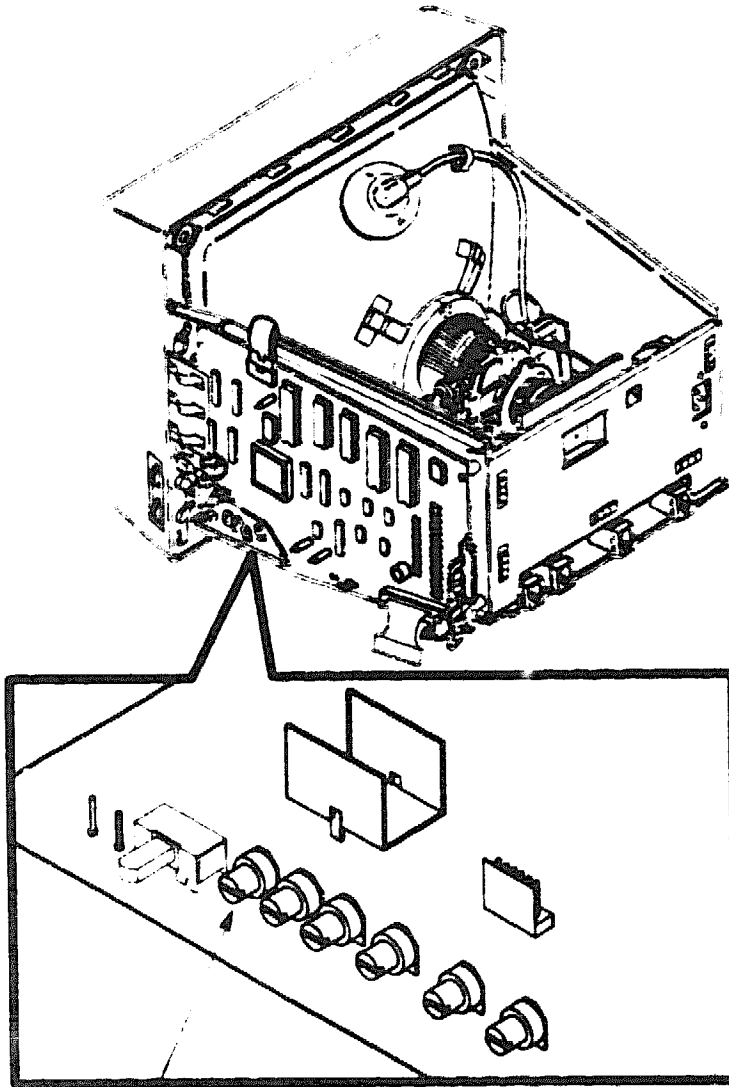

R705
V SIZE

MA X0121 90

4.2.7 Character Quality

This section covers linearity and focus adjustments. To make these adjustments:

1. Run the screen test (Section 4.2.4).

2. Select the crosshatch screen by pressing the **7** key or stop the screen test with the **Hold Session** key when one of the crosshatch screens appears.

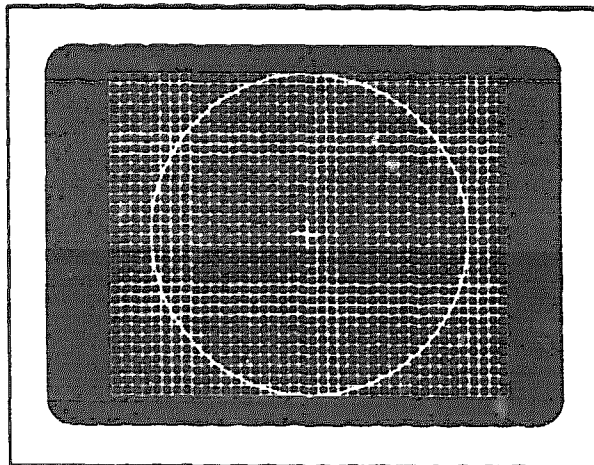
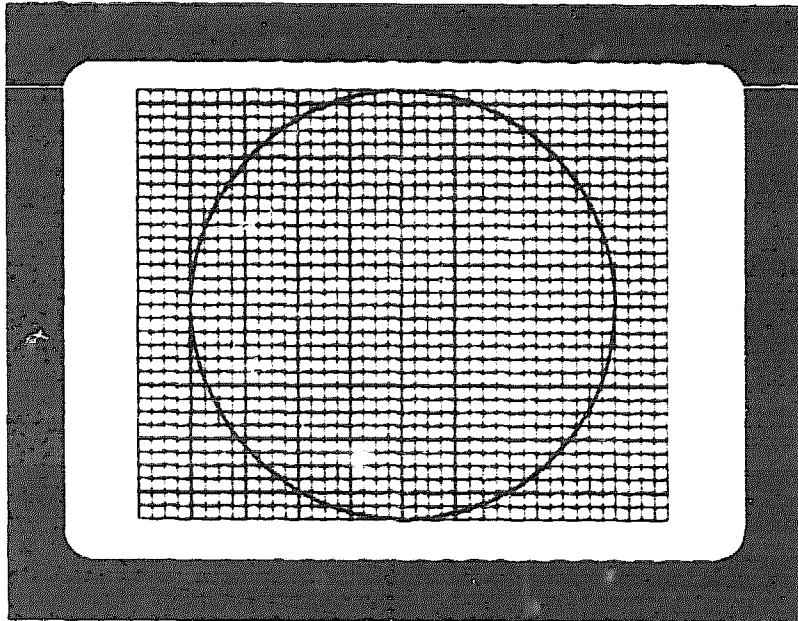

4.2.7.1 Linearity

To check and adjust the linearity:

1. Measure and check the height of the four corner blocks in the test display. Each block must be the same size. Also, check if the circle appears round.
2. If necessary, adjust the R709 (V-LINE) control until the block is the same height in all four corners.
3. If you adjust the linearity, you *must* adjust the vertical height (Section 4.2.6.5).

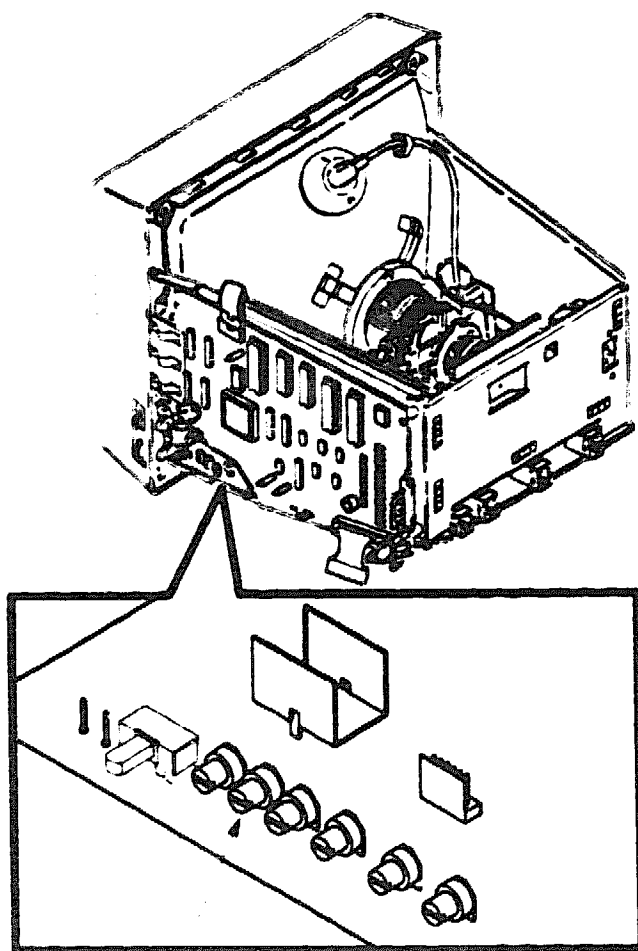

R709
V-LIN

4.2.7.2 Focus

To check and adjust the focus:

1. Select a point on the grid pattern four blocks from the right edge and three blocks down from the top.

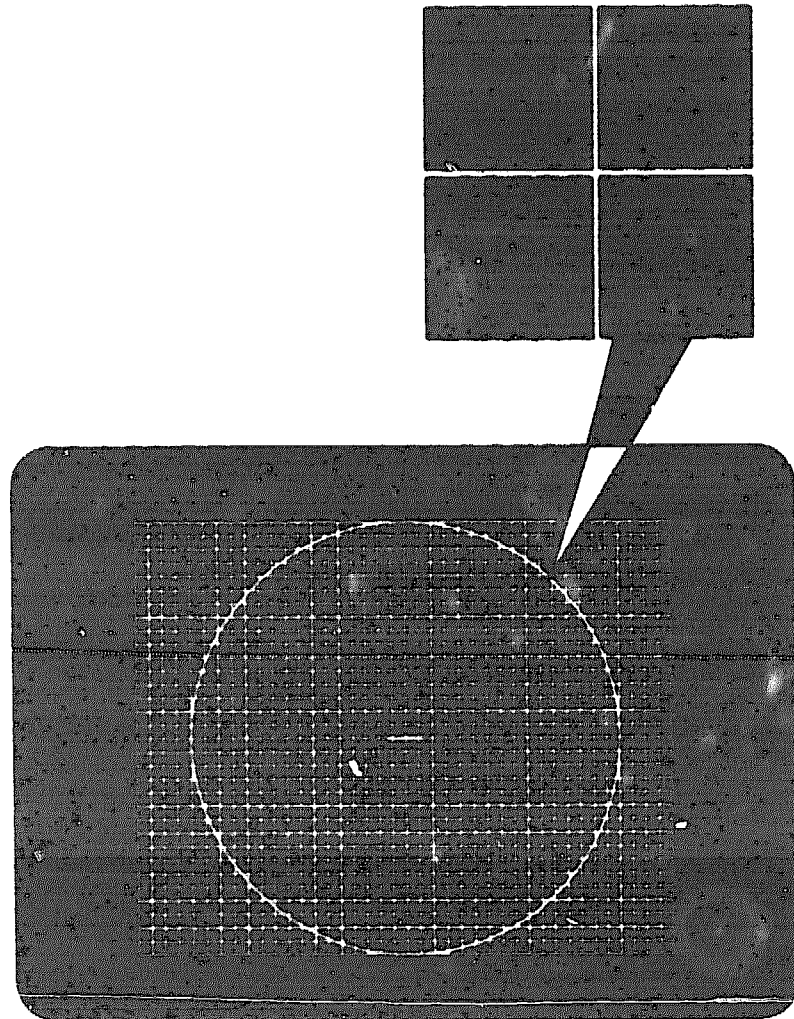

MA-X0917-89

2. Examine the intersecting lines for sharpness.

NOTE

Make sure the screen is clean. A dirty screen can appear to affect the focus. In some cases, the operator may want to set the focus setting to suit personal preferences.

4-26 Aligning the Video Terminal

3. If necessary, adjust the FOCUS control on the flyback transformer so the intersecting lines are sharp.

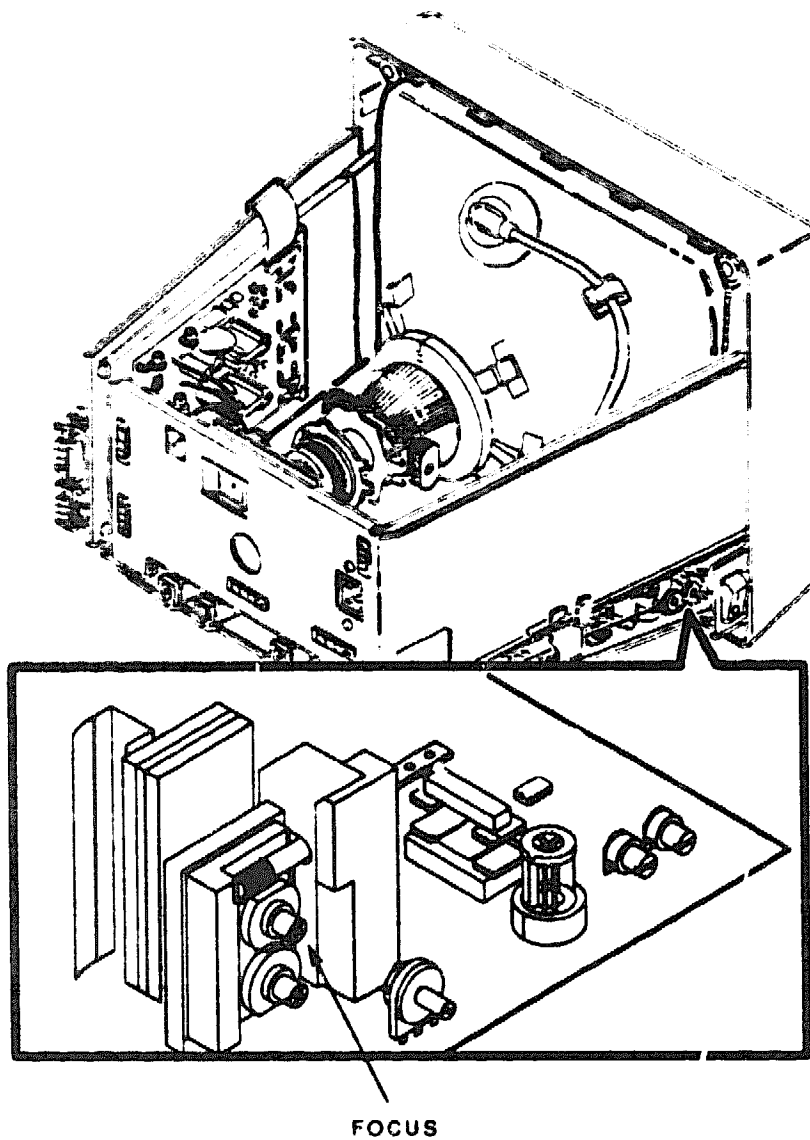

WA X0123-80

4.2.8 Viewer Preference

This procedure lets you set the terminal's brightness and contrast for viewing preference. To make these adjustments:

1. Run the screen test (Section 4.2.4).
2. Select the gray scale by pressing the key or stop the screen test with the key when the gray scale appears.

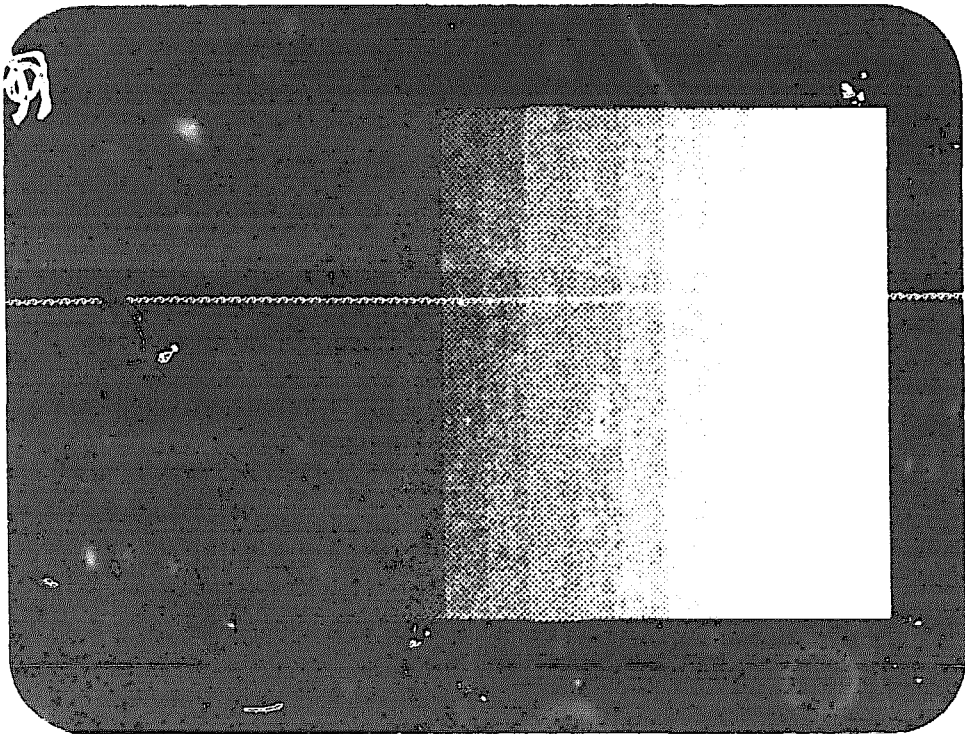

MA X0884 89

3. Adjust the brightness and contrast controls to the preferred viewing level.

4. Select the screen of Es by pressing the **1** key or continue the screen test by pressing the **Hold Session** key and stop the screen test with the **Hold Session** key when the screen of Es appears.

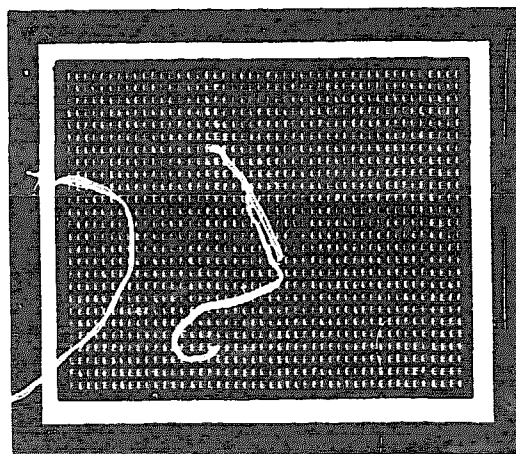
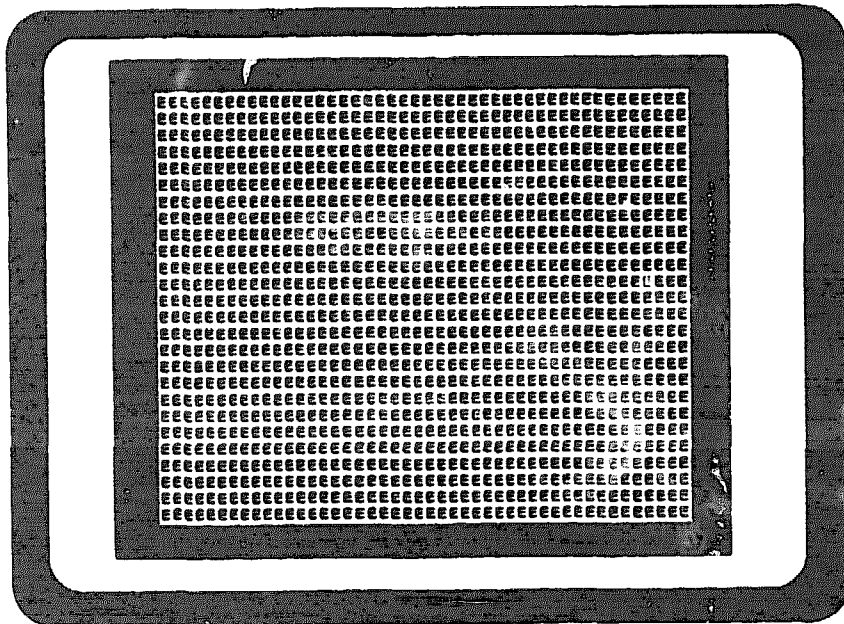

MA 10030 88

5. Check the horizontal width and vertical height (Section 4.2.6.5) of the display. Adjust if necessary.

5

Using Set-Up

This chapter gives a brief summary on how to use a Set-Up utility to change the settings of operating features from the keyboard. Chapter 5 of *Installing and Using the VT330/VT340+ Terminal*, EK-VT3XX-UG describes the Set-Up utility in detail.

5.1 What is Set-Up

The Set-Up utility is a series of display screens. Each screen lists a group of related features, such as communications or diagnostics. Each Set-Up screen has basic directions at the bottom for selecting and changing feature settings. You can move from screen to screen in the Set-Up utility.

5.1.1 Dual Sessions

The VT340+ can run two sessions simultaneously with the host system. Each session has its own settings. If the terminal is set for dual sessions, the Set-Up screens display the settings for the active session. Chapters 3 and 8 of *Installing and Using the VT330/VT340+ Video Terminals*, EK-VT3XX-UG describe how to set up and use dual sessions.

5.2 Entering and Leaving Set-Up

You enter set-up by pressing the **Set-Up** key on the top row of the keyboard. The Set-Up directory screen appears (Figure 5-1). The top half of the directory screen lists all the VT340+ Set-Up screens. The bottom half of the directory screen lists some functions you can perform directly from the Set-Up directory.

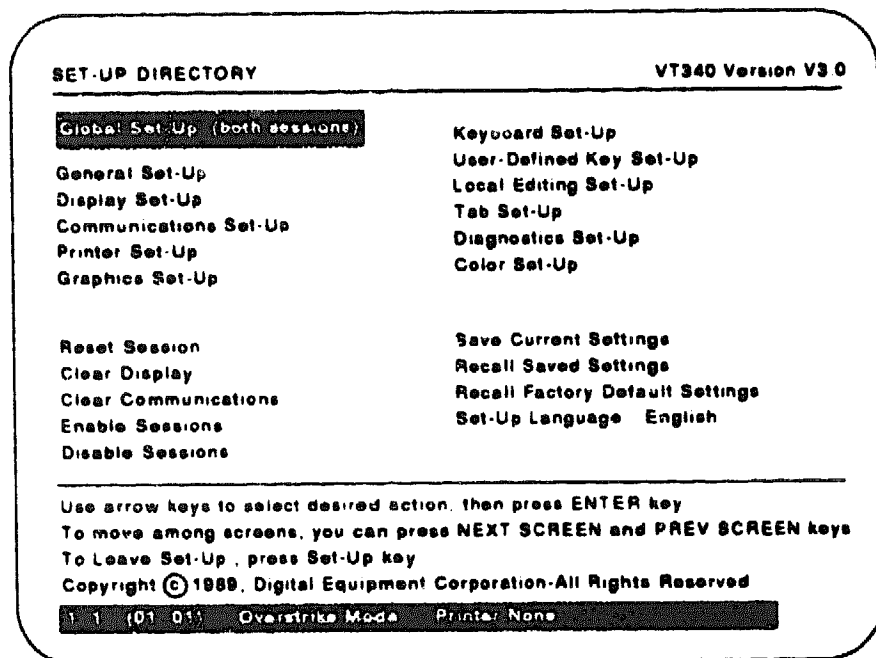

MA X0870 00

Figure 5-1 Set-Up Directory

5.3 Selecting A Set-Up Screen

To select any Set-Up screen from the Set-Up Directory screen:

1. Press the **[Set-Up]** key. The Set-Up Directory appears.
2. Use the arrow keys to move the cursor to the name of the screen you want display.
3. Press the **[Enter]** key.

You can also use the **[Next Screen]** key to move from one Set-Up screen to the next. You can use the **[Prev Screen]** key to back up to a previous screen. The screens appear in the order listed in the Set-Up Directory. You can press the **[Next Screen]** key and the **[Prev Screen]** key when viewing any set-up screen.

4. To return to the Set-Up directory, press the **Set-Up** key.

5.4 Selecting Set-Up Features

You can use the arrow keys to move the cursor to any field on a Set-Up screen. There are two basic types of fields:

- Action fields** When you move to an action field and press the **Enter** key, the terminal performs that action. The Set-Up Directory, User-Defined Key, and Tab screens have action fields.
- Features** Features have more than one setting. You use the arrow keys or the **Enter** key to change the current setting of a feature. When you exit set-up, the terminal uses the new setting you selected.

Do not change any settings unless necessary.

5.5 Saving Set-Up Values

You may want to save the current settings in set-up before you run tests. Check with the user. When you save settings, you can recall them later. You can save all set-up settings as follows. If the terminal is set for dual sessions, this procedure only applies to the active session. To save set-up values:

1. Press the **Set-Up** key. The Set-Up Directory screen appears.
2. Use the arrow keys to move to the **Save Current Settings** field.
3. Press the **Enter** key to save the current settings.

5.6 Recalling Set-Up Values

You can reset the terminal to recall the previous set-up values. There are two types of set-up values you can recall. Check with the user to see which settings were in use.

- Factory-default settings
- Saved settings (previously selected by the user)

You can recall set-up values as follows. If the terminal is set for dual sessions, this procedure applies only to the active session. To recall set-up values:

1. Press the **Set-Up** key. The Set-Up Directory screen appears.
2. Use the arrow keys to select the **Recall Factory Default Settings** or **Recall Saved Settings** field.
3. Press the **Enter** key to recall the selected set-up values.

A

Related Documentation

In addition to this guide, you can order the following VT330/VT340+ documents from Digital:

Documentation	Part Number
Installing and Using The VT330/VT340+ Video Terminals*	EK-VT3XX-UG
VT330/VT340+ Programmer Reference Manual (Two volumes)	
Vol. 1: Text Programming	EK-VT3XX-TP
Vol. 2: Graphics Programming	EK-VT3XX-GP
VT330/VT340+ Programmer Pocket Guide	EK-VT3XX-HR
VT340+ Pocket Service Guide	EK-VT340-PS
VT330+ Video Terminal IPB	EK-VT330-IP
VT340+ Video Terminal IPB	EK-VT340-IP
VT330+ Field Maintenance Print Set	MP-02411-01
VT340+ Field Maintenance Print Set	MP-02412-01
Installing and Using The Session Support Utility	AA-JB84B-TE

*Includes Technical Change Notices (EK-VT3XX-CN)

B

Troubleshooting The Session Support Utility

The VT340+ can run the dual sessions over a single communication line if Digital SSU software is installed on the host system. If you have problems running dual sessions with SSU software, check the software versions and the Set-Up features, as follows:

B.1 Checking Software and Set-Up

To check the software and Set-Up features:

1. Check the software versions running on the system and the terminal as follows:
 - The host system must have VMS Version 4.4 or later; and SSU Version 1.0 or later. See "Restrictions" at the end of the appendix.
 - The VT340+ must have the firmware Version 1.1 or later. You can check the firmware version listed on the top of any Set-Up screen.
2. Make sure the following set-up features are set correctly:

In Global Set-Up:

- **Dual Terminal** should be "enabled".
- **Terminal Comm Ports** should be set to "Sessions Comm1" or "Sessions Comm2", depending on the comm port you are using.

In Display Set-Up:

- **Vertical Coupling** should be "enabled".

B-2 Troubleshooting The Session Support Utility

The rest of this appendix lists symptoms and solutions for SSU problems. Many of the symptoms shown are DCL error messages. To make your error messages appear in the same format as those shown here, type the following command at the DCL \$ prompt:

```
$ set message/nofacility/severity/noid/text
```

B.2 Problems with Enabling SSU Software

When SSU software is installed correctly, you can enable it by typing the following at the \$ prompt:

```
$ ssu enable
```

This section lists some error messages that may appear on the terminal when you try to enable SSU software and their solutions.

Message

```
$ ssu enable
%E, failure to enable multiple sessions on <dev:>
%E, specified device is not associated with a virtual terminal.
```

Solution

- This error is often caused by using the DCL command SET HOST to log into the host system. When you use SET HOST, the system identifies the terminal as an RTxx: device. SSU does not work on RTxx: devices. You must log directly onto the system.
- Use the DCL command SHOW TERMINAL to see if your system has virtual terminals enabled. The first line of the response should show "Terminal":_VTAnnn". If not, this is an SSU problem that needs to be resolved on the host system. Have the system manager do an SSU INSERT on the physical line. See *Installing and Using the Session Support Utility*.

Message

```
$ ssu enable
%E, error opening device TDA:
%W, no such device available
```

Solution

- Make sure (1) SSU was installed without any errors, and (2) the system start-up procedure executes the file called SSU_STARTUP.COM. See *Installing and Using the Session Support Utility*.
- Make sure TDDRIVER is loaded on your VMS system, by typing the following DCL command:

```
$ SHOW DEVICE _TDA
```

You should get a list of terminal devices in the left column including at least TDA0: . If the message "No such device available" appears, TDDRIVER is not loaded correctly. This is an SSU problem that needs to be resolved on the host system. See *Installing and Using the Session Support Utility*.

- Make sure the system TDDRIVER and SSU software have the same version number and that the version is Version 1.0 or later. You can check the version numbers with the following DCL commands:

```
$ ANALYZE/IMAGE
$ SYSSYSTEM:TDDRIVER.EXE

$ ANALYZE/IMAGE
$ SYSSYSTEM:SSU.EXE
```

Look for the line saying "Image file identification:SSU V1.0".

Message

```
$ ssu enable
*W, unrecognized command verb - check validity and spelling
```

Solution

- Make sure all SSU installation instructions were performed correctly, in particular the ones that include the definition of the SSU command in the common user start-up file. See *Installing and Using the Session Support Utility*.

Message

```
$ ssu enable
|@AJ|@AJ|@AJ|@AJ|@AJ|@AJ
```

Solution

- Make sure the set-up features at the beginning of this appendix are set correctly as follows:

In Global Set-Up:

- **Dual Terminal** should be "enabled".
- **Terminal Comm Ports** should be set to "Sessions Comm1" or "Sessions Comm2", depending on the comm port you are using.

In Display Set-Up:

- **Vertical Coupling** should be "enabled".

B.3 DECserver LAT Problems

This section lists DECserver LAT problems and their suggested solutions.

Symptom

Your session(s) were running fine, but now the terminal is not responding. You think that you are still logged into the system.

Solution

- Select **Disable Sessions** in the Set-Up Directory.
- At the **Local>** prompt, reconnect to your VMS system and log in. If system parameters allow disconnected jobs, you may now be able to reconnect to your old job.

Symptom

When you try to enable sessions or open a session, the terminal warning bell sounds or you get thrown back to the **Local>** prompt.

Solution

Make sure you do not set your terminal server "forward" or "local" characters to **Ctrl** or **Ctrl-T**. To be safe, enter the following commands for your terminal server before logging into VMS:

```
Local> set local none  
Local> set forward none
```

Restrictions

- **DECserver 200 lines**

For systems running VAX/VMS Version 4.4 or 4.5: If the LAT+ driver shipped with the DECserver 200 lines is installed, you cannot use SSU on the DECserver 200 lines.

NOTE

The normal LAT driver shipped with VAX/VMS Version 4.4 or 4.5 will work with SSU.

For systems running VAX/VMS Version 4.6 or later and its associated LAT driver with DECserver 200 lines: You can use SSU on DECserver 200 lines.

- **SSU is not supported on the OPA0: device, because of internal differences between this device and all terminal devices on VAX/VMS.**

C

FRU Exploded View Diagrams

Figures C-1 and C-2 show the VT340+ FRUs and their part numbers.

C-2 FRU Exploded View Diagrams

LK201-NA	US/UK
LK201-AC	FRENCH/CANADIAN
LK201-AB	BELGIUM
LK201-ED	DANISH
LK201-NX	FINNISH
LK201-NG	AUSTRIAN/GERMAN
LK201-NH	HOLLAND
LK201-AI	ITALIAN
LK201-AK	SWISS/FRENCH
LK201-AL	SWISS/GERMAN
LK201-NM	SWEDEN
LK201-EN	NORWAY
LK201-AP	FRANCE
LK201-AS	SPANISH
LK201-AV	PORTUGAL
LK201-PA	US/UK WPS (GOLD)

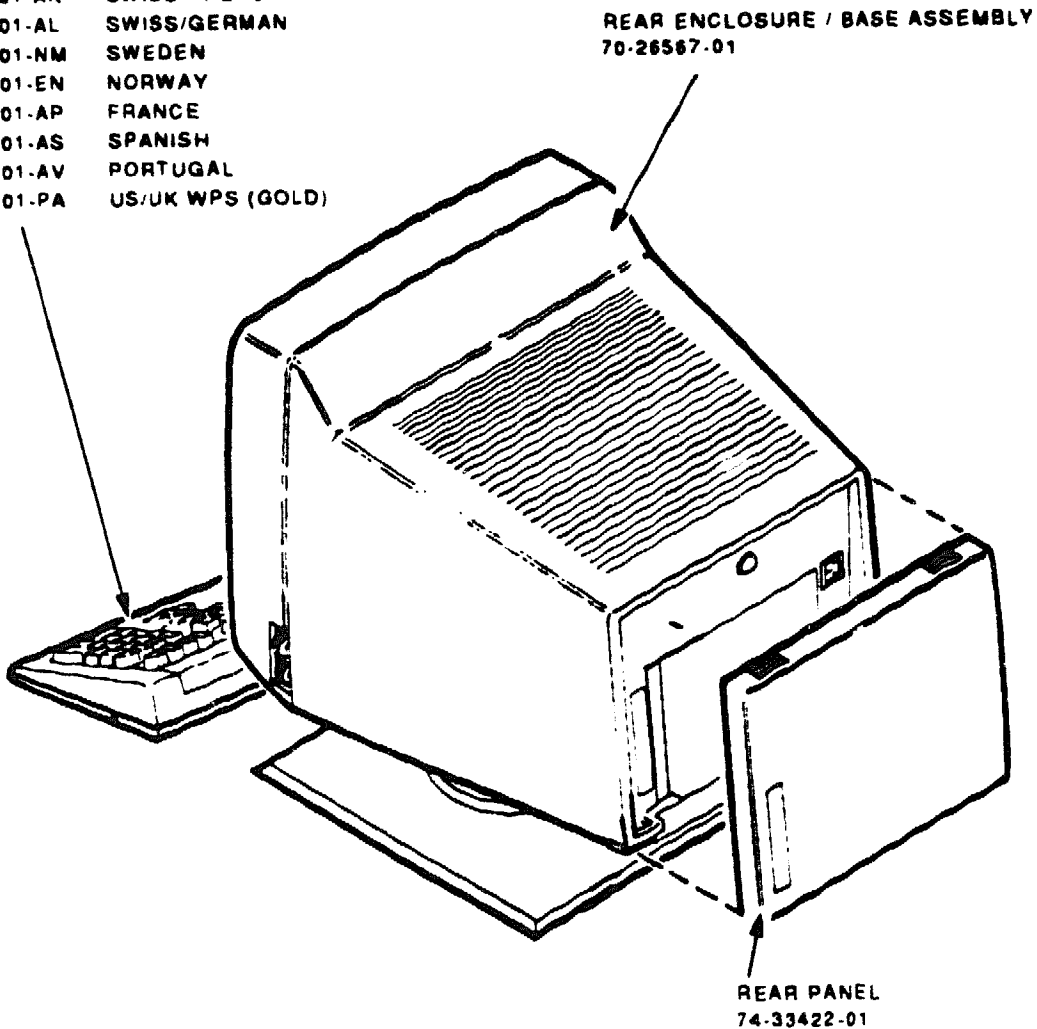

MA X0908-00

Figure C-1 VT340+ FRUs (External View)

CRT/BEZEL/CHASSIS ASSEMBLY
 (NORTHERN HEMISPHERE) 70-26554-01
 (SOUTHERN HEMISPHERE) 70-26554-02

VIDEO AMP
 MODULE
 54-20130-01

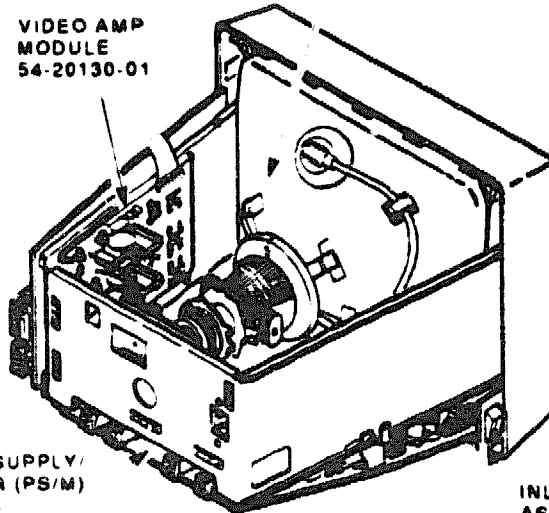

POWER SUPPLY/
 MONITOR (PS/M)
 AND ARC
 PROTECTION
 MODULE
 54-20126-01

INLET/SWITCH
 ASSEMBLY
 70-26548-01

TERMINAL
 CONTROL
 MODULE
 54-20128-01

PS/M AND
 ARC PROTECTION
 ASSEMBLY
 54-20126-01

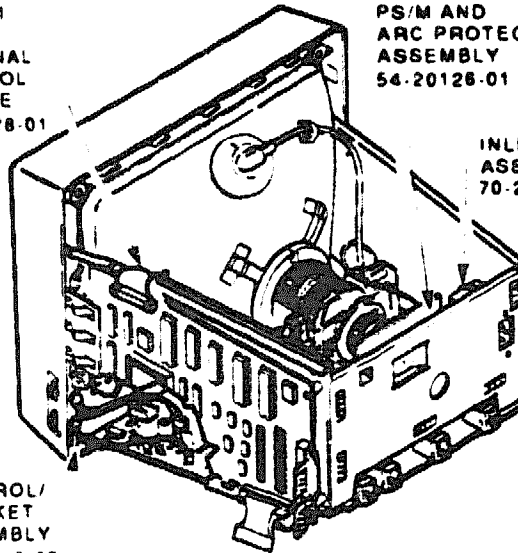

INLET/SWITCH
 ASSEMBLY
 70-26548-01

CONTROL/
 BRACKET
 ASSEMBLY
 70-22618-02

MA 20699-89

Figure C-2 VT340+ FRUs (Internal View)

D

Cables

Table D-1 lists the interface cables, adapters, and their part numbers. Figure D-1 shows the possible cable connections for the VT340+ terminal.

Table D-1 Interface Cables and Adapters

Part Number	Length	Connector
Printer Cables and Adapter (VT420 to printer)		
BC16E-10	10 ft (3 m)	6-pin M*DEC-423 to
BC16E-25	25 ft (7.6 m)	6-pin M*DEC-423
H8751-A adapter	-	6-pin F*DEC-423 to 25-pin F*RS-232
H8751-C or -F adapter	-	25-pin F*RS-232 to 6-pin M*DEC-423
Extension Cables		
BC22E-10	10 ft (3 m)	25-pin F*RS-232 to
BC22E-25	25 ft (7.6 m)	25-pin M*RS-232
Null Modem Cables		
BC22D-xx	-	25-pin F*RS-232 to 25-pin F*RS-232
Communication Cables		
BC16E-10	10 ft (3 m)	6-pin M*DEC-423 to
BC16E-25	25 ft (7.6 m)	6-pin M*DEC-423

*M=male. F=female.

Table D-1 (Cont.) Interface Cables and Adapters

Part Number	Length	Connector
AC Power Cables	Country	
BN20V-2E	Australia, New Zealand	
BN20S-2E	Austria, Belgium, Finland, France, Germany, Netherlands, Norway, Portugal, Spain, Sweden	
BN20P-2E	Canada	
BN20U-2E	Denmark	
BN20R-2E	Ireland, United Kingdom	
BN19U-2E	Israel	
BN20W-2E	Italy	
BN20T-2E	Switzerland	

M = male. F = female.

xx = length in feet (10, 25, 50, 100, 200, 250)

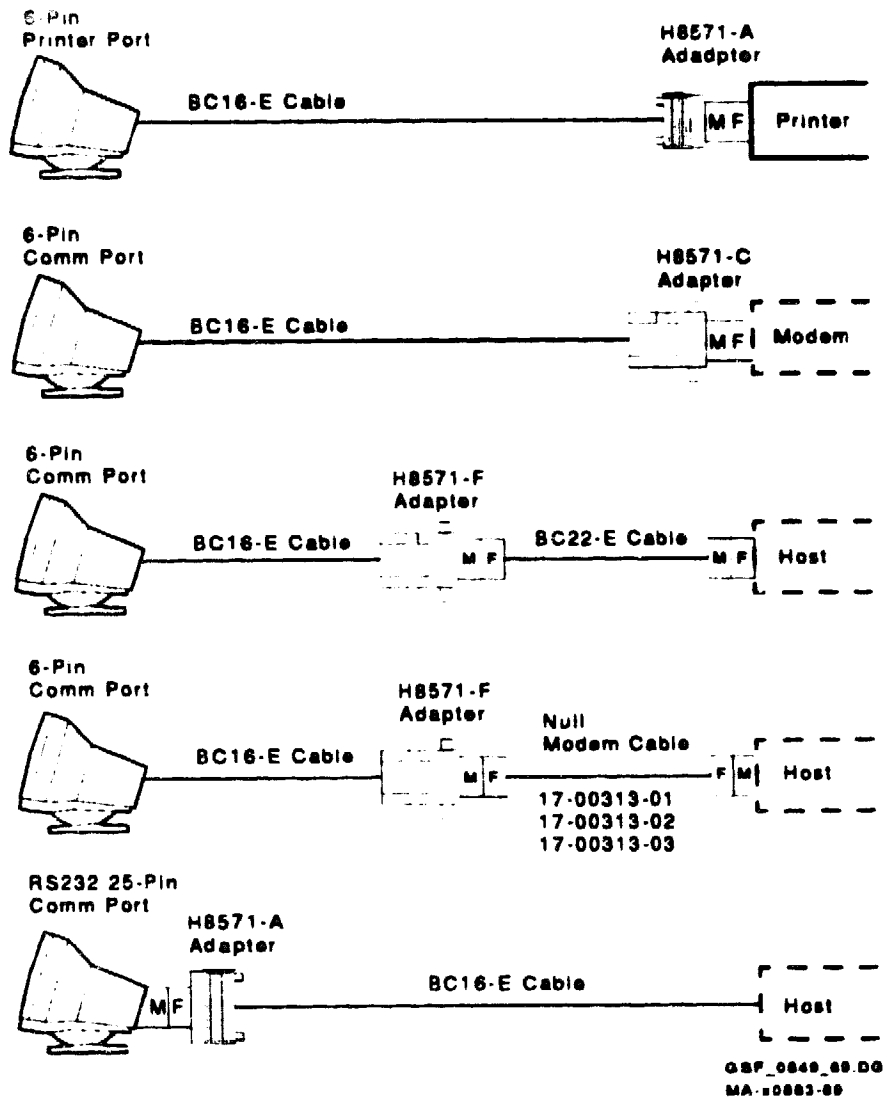

Figure D-1 VT340+ Cable Connections

Physical/Functional Diagram

Figure E-1 is a physical/functional diagram showing how the VT340+ components work together. Table E-1 lists the pin assignments for connectors on the PS/monitor and arc protection assembly, the video amp module, and the terminal control module.

NOTE

All voltage readings are based on a line voltage of 115 Vac. Your readings may differ, depending on your line voltage.

E-2 Physical/Functional Diagram

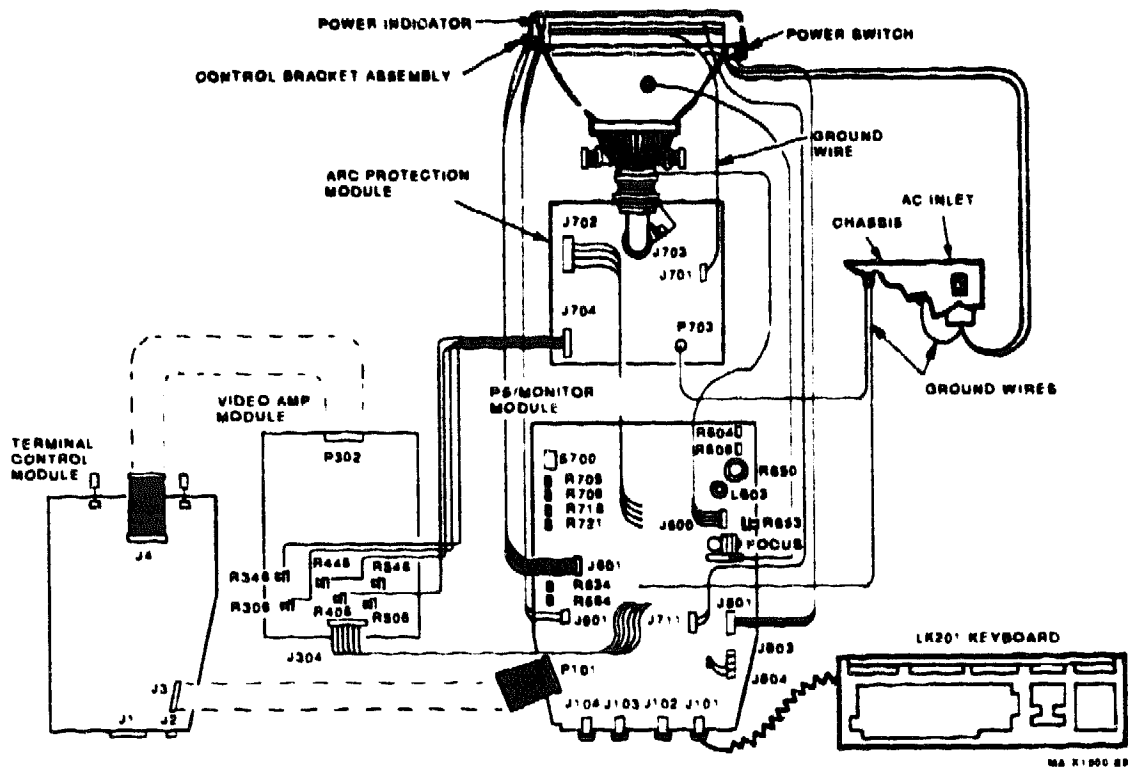

Figure E-1 Connection Diagram

Table E-1 VT340+ Signals and Pin Assignments

Pin	Function	Description
Power Supply/Monitor Module		
J104 Comm1 Port Connector		
1	DTR	Data terminal ready
2	TXD	Transmitted data
3	GND	Transmit ground
4	CMM	Receive ground
5	RXD	Received data
6	DSR	Data set ready
J103 Comm2 Port Connector		
1	DTR	Data terminal ready
2	TXD	Transmitted data
3	GND	Transmit ground
4	CMM	Receive ground
5	RXD	Received data
6	DSR	Data set ready
J102 Printer Port Connector		
1	DTR	Data terminal ready
2	TXD	Transmitted data
3	GND	Transmit ground
4	CMM	Receive ground
5	RXD	Received data
6	DSR	Data set ready

Table E-1 (Cont.) VT340+ Signals and Pin Assignments

Pin	Function	Description
J101 Keyboard Port Connector		
1	TXD	Transmitted data
2	GND	Ground
3	+12 VF	Voltage fused
4	RXD	Received data
J600 CRT Yoke		
1	Hor yoke	Horizontal yoke
2	Hor yoke	Horizontal yoke
3	Vert yoke	Vertical yoke
4	Vert yoke	Vertical yoke
J601 Control Bracket		
1	Brightness	
2	Brightness	
3	Brightness	
4	Contrast	
5	Contrast	
6	Contrast	
J901 DC Power OK Connector		
1	LED	LED output
2	GND	

Table E-1 (Cont.) VT340+ Signals and Pin Assignments

Pin	Function	Description
P801 Power Switch		
1	Line	Line-side switch
2	NC	Not connected
3	Neutral	Neutral-side switch
J711 Degaussing Coil Connector		
1	Neutral	
2	Line	
P702 CRT Connector		
1	GND	Ground
2	G1	Grid 1
3	Heater	
4	G2	Grid 2

Table E-1 (Cont.) VT340+ Signals and Pin Assignments

Pin	Function	Description
Terminal Control Module		
J4 Video Output Connector (To Arc Protection Module)		
1	BO3	Blue video data line
2	BO2	Blue video data line
3	BO1	Blue video data line
4	BO0	Blue video data line
5	BO4	Blue video data line
6	GND	
7	GO3	Green video data line
8	GO2	Green video data line
9	GO1	Green video data line
10	GO0	Green video data line
11	GO4	Green video data line
12	RO4	Red video data line
13	RO3	Red video data line
14	RO2	Red video data line
15	RO1	Red video data line
16	RO0	Red video data line

Table E-1 (Cont.) VT340+ Signals and Pin Assignments

Pin	Function	Description
J3 Interface Connector		
1	BVSYNC	Vertical sync
2	-12 V	
3	BHSYNC	Horizontal sync
4	+12 VF	Voltage fused
5	NC	Not connected
6	+5 V	
7	KBRXD	Keyboard received data

E-8 Physical/Functional Diagram

Table E-1 (Cont.) VT340+ Signals and Pin Assignments

Pin	Function	Description
J3 Interface Connector		
8	+5 V	
9	KBTXD	Keyboard transmitted data
10	+5 V	
11	PTRDSR	Printer port, data set ready
12	+5 V	
13	PTRRXD	Printer port, received data
14	+5 V	
15	PTRCOM	Printer port, receive ground
16	+5 V	
17	PTRTXD	Printer port, transmitted data
18	+5 V	
19	PTRDTR	Printer port, data terminal ready
20	GND	
21	H2DSR	Host port 2, data set ready
22	GND	
23	H2RXD	Host port 2, received data
24	GND	
25	H2COM	Host port 2, receive ground
26	GND	

Table E-1 (Cont.) VT340+ Signals and Pin Assignments

Pin	Function	Description
J3 Interface Connector		
27	H2TXD	Host port 2, transmitted data
28	GND	
29	H2DTR	Host port 2, data terminal ready
30	GND	
31	H1423DSR	Host port 1, DEC-423, data set ready
32	GND	
33	H1423RXD	Host port 1, DEC-423, received data
34	CPU-R	
35	H1423COM	Host port 1, DEC-423, receive ground
36	NC	Not connected
37	H1423TXD	Host port 1, DEC-423, transmitted data
38	GND	
39	H1423DTR	Host port 1, DEC-423, data terminal ready
40	GND	
J2 Mouse Connector		
1	GND	Ground
2	RXD	Received data
3	TXD	Transmitted data
4	-12 V	
5	+5 V	
6	+12 VF	Voltage fused
7	Not used	
8	SHIELD	Ground

Table E-1 (Cont.) VT340+ Signals and Pin Assignments

Pin	Function	Description
J1 EIA 25-Pin Comm1 Connector		
1	GND	Protective ground (open)
2	H1232TXD	Host port 1, RS-232, transmitted data
3	H1232RXD	Host port 1, RS-232, received data
4	H1RTS	Host port 1, ready to send
5	H1CTS	Host port 1, clear to send
6	H1232DSR	Host port 1, RS-232, data set ready
7	SIGNAL GND	
8	H1CD	Host port 1, carrier detect
9	Not used	
10	Not used	
11	Not used	
12	SPDIND	Speed indicator
13	Not used	
14	Not used	
15	Not used	
16	Not used	
17	Not used	
18	Not used	
19	Not used	
20	H1232DTR	Host port 1, RS-232, data terminal ready
21	Not used	
22	Not used	
23	SPDSEL	Speed select
24	Not used	
25	Not used	

Table E-1 (Cont.) VT340+ Signals and Pin Assignments

Pin	Function	Description
J304 DC Power Connector (To Arc Protection Module)		
1	GND	
2	-12 E	
3	ACL	Auto-contrast level
4	+12 V	
5	+72 V	
6	Not used	
7	+120 V	
Arc Protection Module		
J302 Video Input Connector		
1	VIDEO 0	
2	VIDEO 2	
3	GND	
4	VIDEO 1	
J704 Video Input Connector		
1	BLUE OUTPUT	Video
2	GND	
3	GND	
4	GREEN	Video
5	GND	
6	RED	Video