

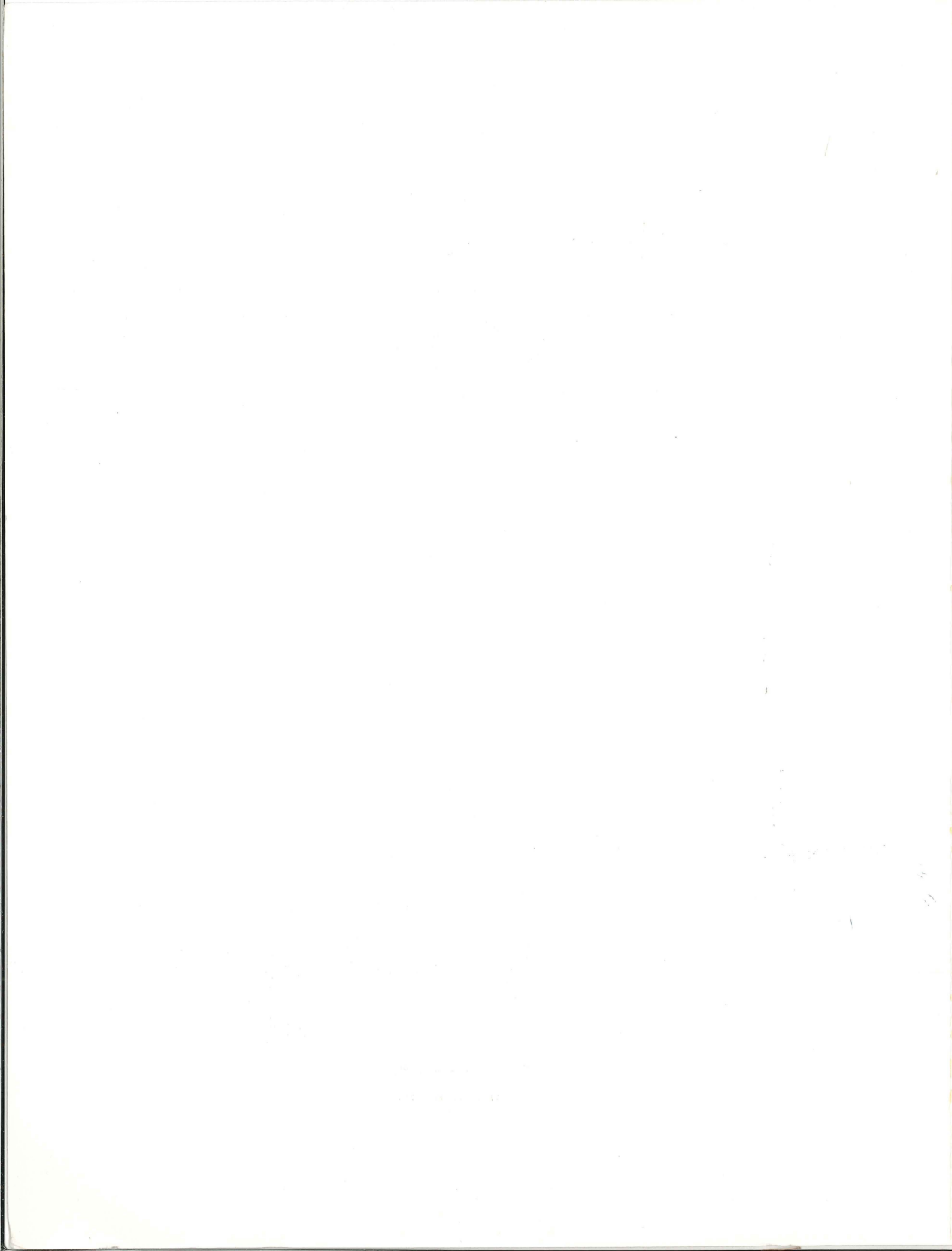

VT225 COLOUR TEXT TERMINAL

Users Manual

digital



EK-VT225-UG-001

VT225
COLOUR TEXT TERMINAL
USER'S GUIDE

Digital Equipment Corporation
(Australia) Pty. Limited

First Edition — September, 1987

The information in this document is subject to change without notice and should not be construed as a commitment by Digital Equipment Corporation or Digital Equipment Corporation (Australia) Pty. Limited. Digital Equipment Corporation and Digital Equipment Corporation (Australia) Pty. Limited assume no responsibility for any errors that may appear in this document.

Copyright ©1987 by Digital Equipment Corporation (Australia) Pty. Limited.

All Rights Reserved.
Printed in Australia.

The postpaid READER'S COMMENTS form on the last page of this document requests the user's critical evaluation to assist in preparing future documentation.

The following are trademarks of Digital Equipment Corporation:

DEC	DIBOL	UNIBUS
DEC/CMS	EduSystem	VAX
DEC/MMS	IAS	VAXcluster
DECnet	MASSBUS	VMS
DECsystem-10	PDP	VT
DECSYSTEM-20	PDT	
DECUS	RSTS	
DECwriter	RSX	

CONTENTS

CHAPTER 1 INTRODUCTION TO THE TERMINAL

GENERAL	1-1
PHYSICAL DESCRIPTION	1-1
Monitor/System Unit	1-2
Keyboard	1-2
FUNCTIONAL DESCRIPTION	1-2

CHAPTER 2 USING THE VT225

GENERAL	2-1
TERMINAL	2-1
Monitor	2-1
Using the VT225 for the First Time.....	2-1
Connecting the VT225 to your Host using EIA-232-D	2-5
Connecting the VT225 to your Host using DEC423	2-5
Colours	2-5
KEYBOARD	2-6
MAIN KEYPAD	2-6
Tab	2-6
Ctrl	2-7
Lock	2-7
Shift	2-7
Return	2-8
Delete	2-8
Compose Character	2-8
EDITING KEYPAD	2-8
AUXILIARY KEYPAD	2-9
TOP-ROW FUNCTION KEYS	2-10
Hold Screen	2-10
Print Screen	2-10
Set-Up	2-10
Data/Talk	2-10
Break	2-12
F11 (ESC)	2-12
F12 (BS)	2-12
F13 (LF)	2-12
F17 (BACK TAB)	2-12
F18 (ERASE FIELD)	2-12
F19 (HOME/CLEAR)	2-13
Function Key Summary	2-13
Shift-Find	2-13

VISUAL INDICATORS	2-14
Hold Screen Indicator	2-14
Lock Indicator	2-14
Compose/Edit Indicator	2-15
Wait Indicator	2-15
AUDIBLE INDICATORS	2-15
Keyclick	2-15
Bell	2-15
CHAPTER 3 OPERATING PROCEDURES	
GENERAL	3-1
OPERATING STATES	3-1
Set-Up	3-1
Local	3-1
On-Line Interactive	3-1
On-Line Edit	3-2
OPERATING MODES	3-2
VT200 Mode, 7-Bit Controls	3-2
VT200 Mode, 8-Bit Controls	3-2
National Replacement Character Sets	3-3
Multinational	3-3
National	3-3
VT100 Mode	3-3
VT52 Mode	3-3
CRT SAVER FEATURE	3-4
COLOUR ON THE VT225.....	3-4
THE VT225 STATUS LINE.....	3-4
PRINTING	3-5
Normal Mode	3-6
Auto Print Mode	3-6
Printer Controller Mode	3-6
Printer Port Mode	3-6
Applications Port Mode	3-7
Controller Mode	3-7
COMPOSING CHARACTERS	3-7
Using a Three-Stroke Compose Sequence	3-9
Using a Two-Stroke Sequence	3-22
Aborting or Restarting a Compose Sequence ..	3-23
LOCAL EDITING	3-23
General	3-23
Editing Keys - Display Movement	3-24
Editing Keys - Cursor Movement	3-25
Editing Keys - Display Modification	3-26

CHAPTER 4 TERMINAL SET-UP

GENERAL	4-1
USING SET-UP	4-1
SET-UP SCREENS	4-1
Screen Title	4-3
Terminal Identifier	4-3
Firmware Version Number	4-3
Set-up Status Line.....	4-3
Fields	4-5
Set-Up Controls and Cursor	4-6
EXAMPLE SET-UP PROCEDURE	4-7
SET-UP SCREEN SUMMARIES	4-8
SET-UP DIRECTORY SCREEN	4-10
DISPLAY SET-UP SCREEN	4-15
GENERAL SET-UP SCREEN	4-19
COMMUNICATIONS SET-UP SCREEN	4-24
PRINTER SET-UP SCREEN	4-29
KEYBOARD SET-UP SCREEN	4-33
TAB SET-UP SCREEN	4-38
EDIT SET-UP SCREEN	4-40
COLOUR SET-UP SCREEN.....	4-45
CREATING A PERSONAL COLOUR PALETTE	4-47

CHAPTER 5 COMMUNICATIONS

GENERAL	5-1
HOST AND PRINTER PORT INTERFACES	5-1
MODEMS	5-6
CABLES	5-6
PRINTERS	5-6
CHARACTER FORMAT	5-6
TERMINAL/HOST DATA FLOW CONTROL	5-8
Conditions That Transmit XON	5-9
Conditions That Transmit XOFF	5-9
Buffer Overflow Prevention	5-9
Use of Fill Characters	5-11
Connect/Disconnect	5-11
TRANSMISSION IN EDIT MODE	5-12
Block Size	5-12
Data Compression	5-13
Transmission Example	5-14
Transmission in Edit Mode	5-15
TERMINAL/PRINTER DATA FLOW CONTROL	5-15

CHAPTER 6 PROBLEM SOLVING

GENERAL	6-1
COMMON OPERATING PROBLEMS	6-1
POWER-UP SELF TEST	6-2
PERFORMING THE POWER-UP SELF TEST	6-3
DIGITAL SERVICE	6-4

APPENDIX A SPECIFICATIONS	A-1
---------------------------------	-----

APPENDIX B OPTIONS, DOCUMENTATION AND SUPPLIES	B-1
---	-----

APPENDIX C KEYBOARDS	C-1
----------------------------	-----

TABLES

2-1	Terminal Controls, Indicators and Connectors..	2-3
2-2	Monitor Controls and Tilt Leg Release Button..	2-4
3-1	Valid Compose Sequences	3-5
3-2	Valid Compose Sequences: National Mode	3-9
4-1	Status Line Messages	4-4
4-2	Set-Up Controls and Cursor Functions	4-6
4-2A	Set-Up Display Summary	4-9
4-3	Set-Up Directory Screen	4-10
4-4	Display Set-Up Screen	4-15
4-5	General Set-Up Screen	4-19
4-6	Communications Set-Up Screen	4-24
4-7	Printer Set-Up Screen	4-29
4-8	Keyboard Set-Up Screen	4-33
4-9	Tab Set-Up Screen	4-39
4-10	Edit Set-Up Screen	4-41
4-11	Colour Set-Up Screen.....	4-45
5-1	Comm Port EIA-232-D Interface Signals	5-2
5-2	Printer Port EIA Interface Signals	5-5
6-1	Common Operating Problems	6-1
6-2	Screen Error Messages	6-4

FIGURES

1-1	VT225 Video Terminal	1-1
2-1	Terminal Controls, Indicators and Connectors ..	2-2
2-2	Monitor Controls	2-4
2-3	Keyboard (North American)	2-6
2-4	Main Keypad	2-7
2-5	Editing Keypad	2-9
2-6	Auxiliary Keypad	2-9
2-7	Top Row of Function Keys and Visual Indicators	2-11
4-1	Set-Up Screens	4-2
4-2	Sample Set-Up Screen	4-2
4-3	Set-Up Directory	4-10
4-4	Display Set-Up	4-15
4-5	General Set-Up	4-19
4-6	Communications Set-Up	4-24
4-7	Printer Set-Up	4-29
4-8	Keyboard Set-Up	4-33
4-9	Tab Set-Up	4-38
4-10	Edit Set-Up	4-40
4-11	Colour Set-Up Screen	4-46
5-1	Cables	5-7
5-2	Character Format	5-8
6-1	Successful Power-Up Screen Message	6-3

KEYBOARDS

C-1	NORTH AMERICAN	C-2
C-2	UNITED KINGDOM	C-3
C-3	BELGIUM (FLEMISH)	C-4
C-4	CANADA (FRENCH)	C-5
C-5	DENMARK	C-6
C-6	FINLAND	C-7
C-7	FRANCE/BELGIUM	C-8
C-8	GERMANY/AUSTRIA	C-9
C-9	HOLLAND	C-10
C-10	ITALY	C-11
C-11	NORWAY	C-12
C-12	SPAIN	C-13
C-13	SWEDEN	C-14
C-14	SWITZERLAND (FRENCH)	C-15
C-15	SWITZERLAND (GERMAN)	C-16

PREFACE

This manual provides the information you need to operate and maintain your VT225. The manual is organized into six chapters, and three appendices. These major divisions are described below:

- CHAPTER 1 AN INTRODUCTION TO THE TERMINAL, introduces you to the VT225. It provides an overview of what the terminal is, what it does, and briefly how it works.
- CHAPTER 2 HOW TO USE YOUR VT225, describes the terminal controls, indicators and connectors and shows their locations.
- CHAPTER 3 SPECIFIC OPERATING PROCEDURES, provides information on specific terminal functions and operating procedures.
- CHAPTER 4 TERMINAL SET-UP, describes each SET-UP feature in detail and how to select those features to define the terminal operating characteristics.
- CHAPTER 5 COMMUNICATION, describes how the VT225 communicates with a host computer and how it interfaces with an auxiliary device such as a printer.
- CHAPTER 6 PROBLEM SOLVING, describes the self-test used to locate terminal hardware problems. This chapter also contains simple troubleshooting information to correct common operating problems.
- APPENDIX A SPECIFICATIONS, provides all VT225 specifications.
- APPENDIX B OPTIONS, DOCUMENTATION & SUPPLIES, describes the options, related documentation and supplies mentioned in this manual and how to order them.
- APPENDIX C KEYBOARDS, shows illustrations of all national keyboards for the VT200 Series.

GENERAL

This Chapter introduces you to the VT225 Colour Text Terminal. It provides an overview of what the VT225 terminal is, what it does, and briefly how it works.

PHYSICAL DESCRIPTION

The two main components of the VT225 are the monitor/system unit, and the keyboard (Figure 1-1).

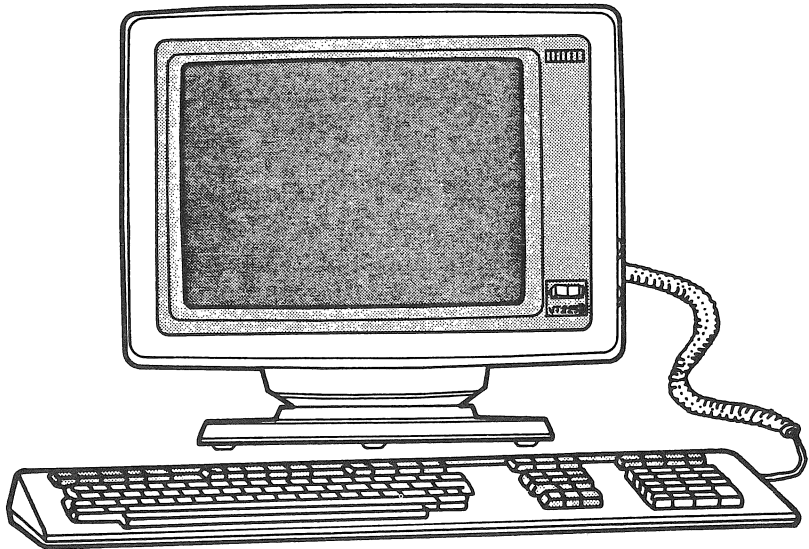

SN-0005-87

Figure 1-1 VT225 Colour Text Terminal

Monitor/System Unit

The monitor/system unit (referred to as "terminal" for the sake of brevity from this point on) consists of a colour cathode-ray tube (CRT), a terminal controller module video and deflection modules and a power supply.

Keyboard

The keyboard is a low profile typewriter-like keyboard that connects to the terminal by a single coiled cable.

FUNCTIONAL DESCRIPTION

The VT225 is a general purpose colour video terminal. It has:

- o high resolution colour text display
- o eight user selectable colour palettes
- o user definable colour palette (8 colours chosen from 64)
- o reverse video character attribute
- o underline character attribute
- o bold character attribute
- o blink character attribute
- o double-height/double width line attribute
- o fifteen characters sets of 94 characters each
- o down-line loadable character set
- o user-definable function keys
- o ANSI compatible control functions
- o VT52 and VT100 modes
- o all the features of a VT220
- o all the features of a VT220-Z or VT22Z
- o multi-page memory (up to 4 pages of 24 lines each)
- o block transmission
- o local editing
- o protected and unprotected fields
- o bidirectional serial printer port
- o 25th line, terminal status or host writable
- o non volatile storage of set up parameters, user definable keys, and colours
- o CRT saver
- o 50 or 60 Hz screen refresh rate

The VT225 sends characters typed on the keyboard to the host computer, and displays on the screen characters received from the host computer. The host computer can also use standard ANSI control sequences to control many aspects of terminal operations.

The VT225 allows the user to set many different parameters, using the SET-UP screens described in Chapter Four, the setting of some of these parameters will need to be decided in conjunction with the system manager, others can be selected by the user.

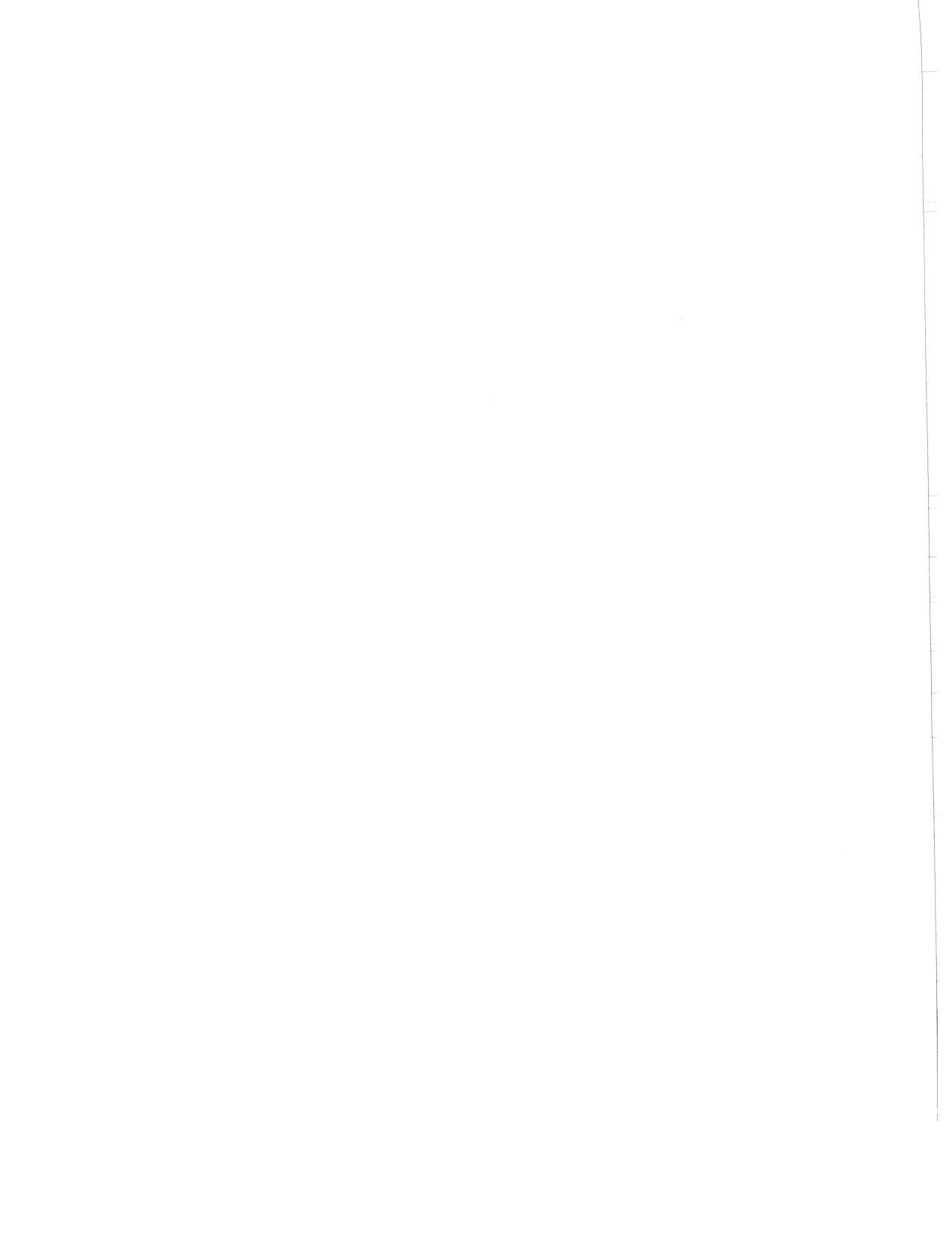

GENERAL

This Chapter provides information about using the terminal's controls, indicators, and connectors. It also includes information on the various keypads and special function keys of the keyboard.

Sufficient information is provided so that the VT225 can be used for the first time.

Terminal

The terminal controls, indicators, and connectors are shown in Figures 2-1 and 2-2 and described in Tables 2-1 and 2-2.

Monitor

The monitor controls are shown in Figure 2-2 and described in Table 2-2.

Using The VT225 For The First Time

After unpacking the VT225, check for shipping damage, then connect the VT225 to the mains, and turn on using the switch on the front panel.

NOTE: Check that the mains voltage is correct for your terminal. The rated mains voltage is shown on the label at the rear of the Terminal.

The VT225 will perform its internal tests and display the message:

VT225	V1.0	OK
-------	------	----

Press the "SET-UP" key (third key from top left).

The display should change to "Set-Up Directory". This is described in more detail in Chapter 4. Note whether the field underneath "Display" reads "On Line".

Press "Enter" (extreme bottom key on right), the display changes to "Display Set-Up". Note whether the lower left field reads "ANSI Colour".

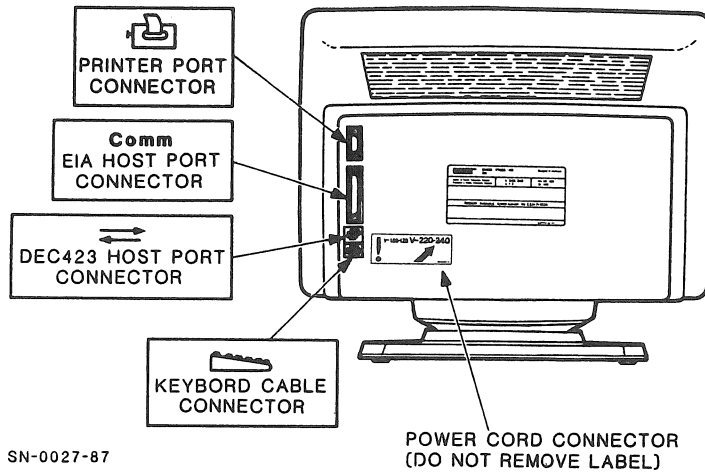

SN-0027-87

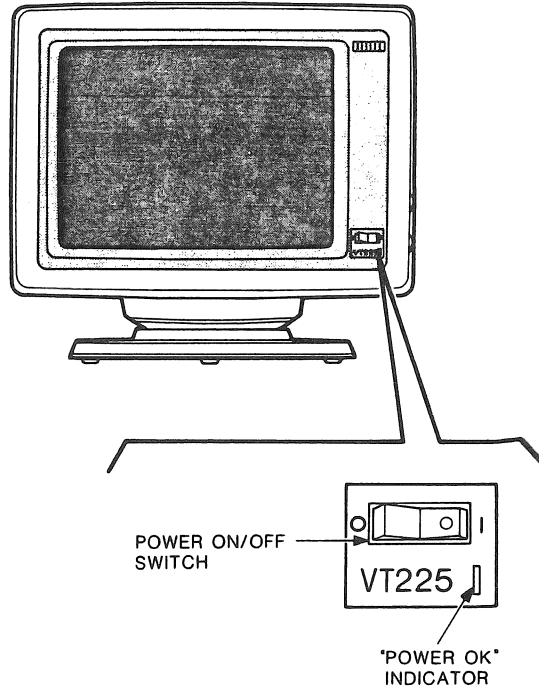

SN-0004-87

Figure 2-1 Terminal Controls, Indicators and Connectors

Table 2-1 Terminal Controls, Indicators and Connectors

Control/Indicator/Connector	Description
Power Switch	Turns the terminal on or off. Pressing 1 turns power ON; pressing 0 turns power OFF.
Power OK Indicator	Lights to indicate power is applied to the terminal.
Cursor	The cursor indicates where the next alphanumeric character will appear. The cursor can be selected in Set-Up to be displayed as an underline cursor or block cursor, blinking or non-blinking.
EIA-232-D Host Port Connector	Used to connect the terminal to a host computer either directly or via a modem.
DEC423 Host Port Connector	Used to connect the terminal to a nearby host computer via DEC423 local direct connection.
Printer Port Connector	Used to connect a printer to the terminal.
Keyboard Connector	Used to connect the keyboard cable to the terminal.
AC Input Connector	Used to connect the power cord from the terminal to the wall outlet.

Press "Enter" again and observe that in the "General Set-Up" VT220 mode, 7 bit controls are displayed. If not, refer to Chapter 4 to change this field.

Press "Enter" again and observe that the transmit and receive speeds are 4800 baud and the "EIA-232-D port, data leads only" is displayed. See Chapter 4 to change fields if necessary.

Press "SET-UP" again to exit.

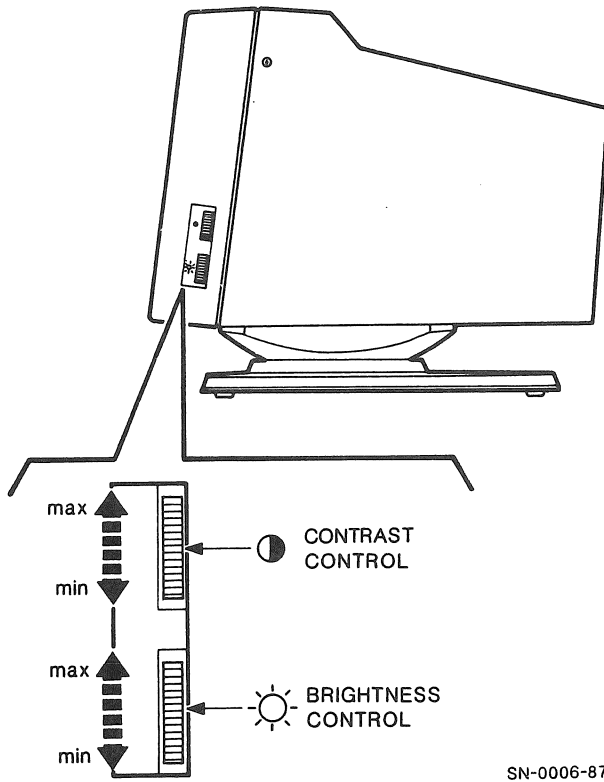

SN-0006-87

Figure 2-2 Monitor Controls

Table 2-2 Monitor Controls

Control	Description
Contrast Control	Adjusts the degree of contrast on the monitor screen.
Brightness Control	Adjusts the degree of brightness on the monitor screen.

Connecting The VT225 To Your Host Using EIA-232-D

Connect to your host by plugging the cable into the EIA-232-D point on the rear of the terminal. If your communication speed is 4800 baud, the terminal will work as a normal terminal.

If your communication speed is not 4800 baud, modify by pressing "SET-UP" then "Enter" three times to get to the "Communication Set-Up" display.

Using the right arrow key --> move the highlighted box to Transmit = 4800. Cycle through the available speeds with the "Enter" key. When the correct one is displayed press "SET-UP" to exit and to use your terminal normally.

Connecting the VT225 to your host using DEC423

Connect to your host by plugging the DEC423 cable into the DEC423 host port at the rear of the terminal.

Press "Set-Up" then "Enter" three times to reach the "Communication Set-Up" display. Using the down arrow to the move the highlighted box to "EIA-232-D Port" and use the "Enter" key to cycle through the options to "DEC423 port, data leads only". Press "Set-Up" to exit.

If your communication speed is not 4800 baud, modify by pressing "SET-UP" then "Enter" three times to get to the "Communication Set-Up" display.

Using the right arrow key --> move the highlighted box to Transmit = 4800. Cycle through the available speeds with the "Enter" key. When the correct one is displayed press "SET-UP" to exit and to use your terminal normally.

Colours

Colours on the VT225 are grouped into palettes. There are eight palettes, including an ANSI standard palette, and a user definable palette. The Set-up procedures can be used to change palettes (See Chapter 4 for more details).

To look at the different palettes press "Set-Up" and "Enter" to enable the "Display Set-Up". Move the highlighted block down to "ANSI Colour", and change the field using the "Enter" key. Press "Set-up" to exit.

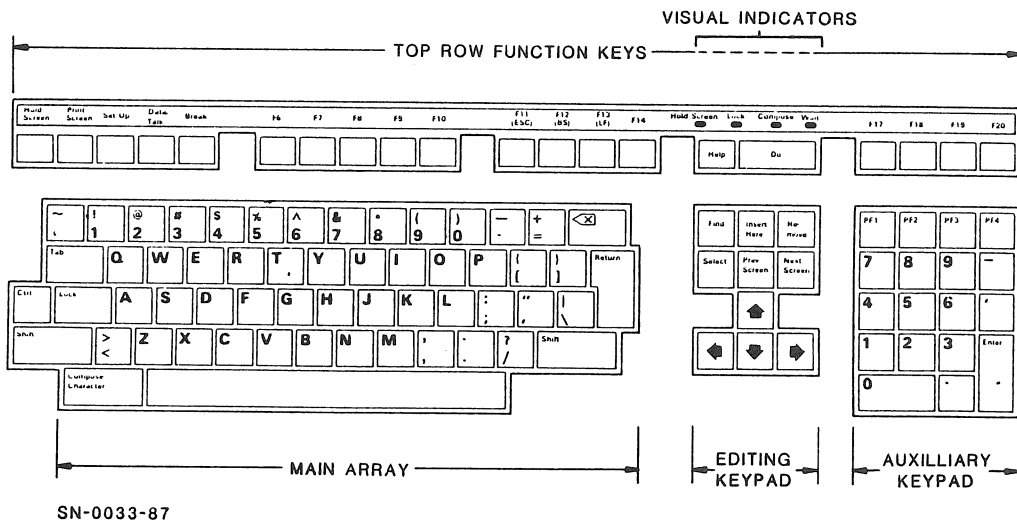

Figure 2-3 Keyboard (North American)

KEYBOARD

The keyboard shown in Figure 2-3 consists of the following:

- o Main Keypad
- o Editing Keypad
- o Auxiliary Keypad
- o Top-Row Function Keys
- o Four Visual Indicators
- o Two Audible Indicators

MAIN KEYPAD

The main keypad (Figure 2-4) operates like a standard typewriter keyboard.

Special function keys on the main keyboard are:

- Tab
 - In the On-Line state pressing the Tab key transmits a horizontal tab, which normally moves the cursor to the next tab stop.
 - In the On-Line-Edit state, pressing the Tab key will move the cursor to the next unprotected tab position or the next unprotected field, whichever occurs first.

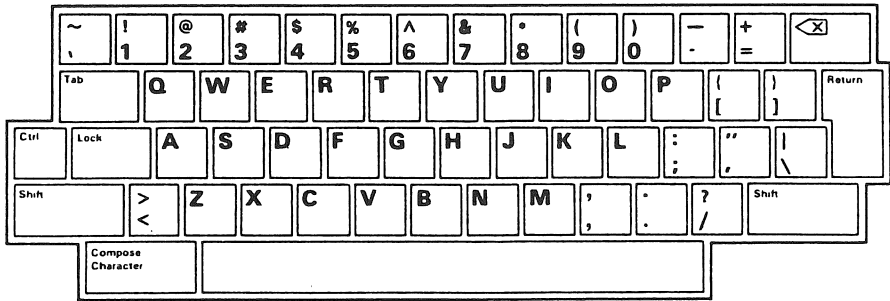

MA 1018-82

Figure 2-4 Main Keypad

Ctrl

Holding down the Ctrl key and pressing another key transmits a control code to the system. A control code tells the system to perform a predefined operation.

Throughout this manual, a keyboard control function using the Ctrl key is shown as:

Ctrl-(other key)

For example, Ctrl-z means to press and hold the Ctrl key while pressing the z key.

Lock

When pressed, the Lock key makes the alphabetic keys generate upper-case characters. When the Lock key is pressed again, the alphabetic keys generate lower-case characters.

Shift

Holding down the Shift key and pressing another key generates uppercase characters, or the top symbol on two character keys.

In some cases, the Shift key is used in combination with another key to generate a predefined control function. Throughout this manual, a keyboard control function using the Shift key is shown as:

Shift-(other key)

For example, Shift-Find means to press and hold the Shift key while pressing the Find key.

Return

Pressing the Return key generates either a carriage return or a carriage return and linefeed (selected in General Set-Up). In some cases, Return moves the cursor to the next line when editing text. In others, Return is a signal to the system that a particular operation is finished.

<X] (Delete)

Pressing the <X](Delete) key generates a DEL character. Normally <X](Delete) erases one character to the left of the cursor. Typing Shift-<X](Delete) generates a CAN (Cancel) character.

Compose Character

The Compose Character key is used to create characters that do not exist as standard keys on your keyboard. Use of this key is described in the "Composing Characters" section in Chapter 3.

EDITING KEYPAD

The editing keypad (Figure 2-5) is normally used to control the cursor and edit data that you have already entered when in the On-Line-Edit state.

In a typical editing operation, the four arrow keys move the cursor in the direction indicated by the arrow. The six editing keys have functions corresponding to their legends. Refer to Section 3 of this manual for specific information.

The Shift-Find key is used to change the type of display on the 25th line of the display.

AUXILIARY KEYPAD

The auxiliary keypad (Figure 2-6) is used to enter numeric data as you would with a standard calculator. The PF1, PF2, PF3 and PF4 keys however, can have functions assigned to them by the application software in use. Refer to your application software manual for specific information.

When the VT225 is in the immediate mode, typing Shift-PF1 will switch the terminal between interactive and edit modes immediately. When the VT225 is in the deferred mode, typing Shift-PF1 will send an escape sequence to the host computer requesting changes between interactive and edit operations.

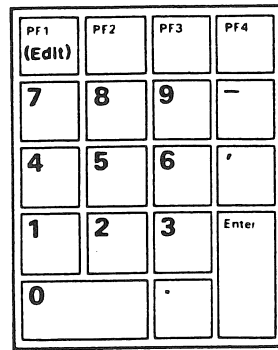
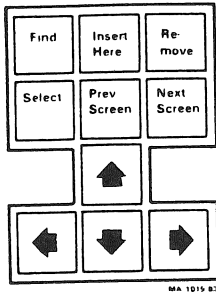

Figure 2-5 Editing Keypad

Figure 2-6 Auxiliary Keypad

TOP-ROW FUNCTION KEYS

Most of the top-row function keys (Figure 2-7) have functions assigned to them by the application software in use. Your application software manual should describe the function of these keys. The following paragraphs describe the predefined top-row keys.

Hold Screen

Pressing the Hold Screen key freezes the screen display and stops any new characters from being displayed. Pressing the Hold Screen key again returns the terminal to normal operation.

Print Screen

Pressing the Print Screen key sends the text on the screen to the printer.

Typing Ctrl-Print Screen sets or resets Auto Print Mode (see Chapter 3, Auto Print Mode).

Set-Up

Pressing the Set-Up key causes the terminal to enter or exit the Set-Up state (see Chapter 4).

Data/Talk

The Data/Talk key is functional only if modem controls have been enabled (see Chapter 4).

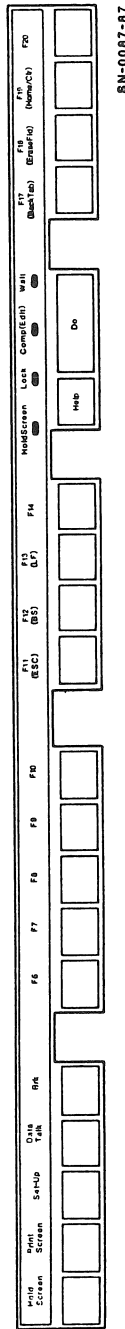

SN-0087-87

Figure 2-7 Top Row of Function Keys and Visual Indicators

Break

The Break key is used alone or with other keys to perform an operation.

- o Pressing the Break key alone transmits a break if break is enabled in Set-Up (see Chapter 4, Keyboard Set-Up Screen).
- o Shift-Break initiates a disconnect (see Chapter 5).
- o Ctrl-Break sends the answerback message to the host computer (see Chapter 4, Keyboard Set-Up Screen).

F11 (ESC)

Although F11 is normally a function key used by application programmes, in VT100 and VT52 modes, it generates an ESC character.

F12 (BS)

Although F12 is normally a function key used by application programmes, in VT100 and VT52 modes, it generates a BS character.

F13 (LF)

Although F13 is normally a function key used by application programmes, in VT100 and VT52 modes, it generates an LF character.

F17 (BACK TAB)

When the VT225 is set to the Interactive state, F17 is a function key used by the application programme.

When the VT225 is set to the On-Line-Edit state, F17 performs the back tab or back field function.

F18 (ERASE FIELD)

When the VT225 is set to the Interactive state, F18 is a function key used by the application programme.

When the VT225 is set to the On-Line-Edit state, F18 performs the Erase Field function.

F19 (HOME/CLEAR)

When the VT225 is set to the Interactive state, F19 is a function key used by the application programme. When the VT225 is set to the On-Line-Edit state, F19 performs the following functions:

- o Pressing F19 alone will move the cursor to the home position.
- o Shift-F19 will clear all unprotected fields on the VT225 screen.

Function Key Summary

The following keys are function keys used by application programmes. For any particular application, each key takes on a meaning as defined by that particular application programme. The meaning of a key may or may not correspond to the legend of the key. The table below includes typical uses for each key. Actual use is dependent on the application.

Shift-Find

The Shift-Find Key changes the information displayed on the 25th line of the terminal. Successive keystrokes will switch the line between:

- o Blank, No status display.
- o The Indicator Status Line.
- o The Host Writable Status Line.

Legend	Typical Use
F6	Defined by the application
F7	Defined by the application
F8	Defined by the application
F9	Defined by the application
F10	Defined by the application
F11 (ESC)	Defined by the application
F12 (BS)	Defined by the application
F13 (LF)	Defined by the application
F14	Defined by the application
Help	Defined by the application
Do (EDIT FUNCTION)	Defined by the application
F17 (BACK TAB)	Defined by the application
F18 (ERASE FIELD)	Defined by the application
F19 (HOME/CLEAR)	Defined by the application
F20	Defined by the application
(<-) (PAGE SCROLL)	Cursor positioning
(->) (PAGE SCROLL)	Cursor positioning
(↑) (LINE SCROLL)	Cursor positioning
(↓) (LINE SCROLL)	Cursor positioning
Find	Editing functions
Shift - Find	25th STATUS Line Control
Insert Here	Editing functions
Remove	Editing functions
Select	Editing functions
Prev Screen	Editing functions (SCROLL TO PREV PAGE)
Next Screen	Editing functions (SCROLL TO NEXT PAGE)
PF1 (EDIT)	Defined by the application
PF2	Defined by the application
PF3	Defined by the application
PF4	Defined by the application

VISUAL INDICATORS

The keyboard has four visual indicators showing the present status or operation in progress.

Hold Screen Indicator

The Hold Screen indicator is on when the video monitor screen is frozen (see Hold Screen).

Lock Indicator

The Lock indicator comes on to indicate that the terminal will generate uppercase characters only (see Lock).

Compose/Edit Indicator

The Compose/Edit indicator, indicates multiple states:

- o OFF - On-line - Interactive state
- o ON - On-line - Edit state
- o BLINKING - Compose sequence (see Chapter 3)

Wait Indicator

The Wait indicator is on when the keyboard is prevented ("locked") from transmitting information. This "locked" condition can be corrected by invoking the "Clear Comm" or "Reset Terminal" feature from the Set-Up Directory Screen (Chapter 4). See the Programmer's Manual for the reasons that cause keyboard lock to occur.

AUDIBLE INDICATORS

The keyboard generates two sounds selectable in the Set-Up state; Keyclick and Bell (Margin Bell and Warning Bell).

Keyclick

The keyclick sound is generated each time you press a key with the following exceptions.

- o You press Shift or Ctrl. These keys do not generate a keyclick because they do not generate a character. They modify characters generated by other keys.
- o When the Wait indicator is on; characters from the keyboard are lost.
- o The Keyclick Set-Up feature is off.

Bell

The bell tone sounds in each of the following cases.

- o As part of the power-up self test.
- o The terminal receives a bell character from the computer (BEL).
- o When a compose error is made.
- o When the right margin is approached (if enabled).

GENERAL

This Chapter provides information that enables you to become familiar with some specific terminal functions and operating procedures. However, the main reference source for a terminal operator, is the documentation describing the application software being used.

OPERATING STATES

The VT225 uses five operational states which are selectable by the operator. These states are:

- o Set-Up
- o Local
- o On-Line Interactive
- o On-Line Edit Mode
- o Off-Line

Set-Up

Set-Up is selected from the keyboard by pressing the Set-Up key. The Set-Up state is used to configure or examine terminal operating features. Chapter 4 describes these Set-Up features in detail.

Local

The Local state is selected while in Set-Up, and is used to effectively place the host computer on "hold". Data received from the host computer is stored and then directed to the terminal monitor after the terminal is returned to the on-line state. In Local, data entered at the keyboard is sent to the monitor and not to the host computer.

On-Line Interactive

The On-Line Interactive state is selected while in Set-Up, and is used to let the terminal communicate with a host computer. When the terminal is on-line, data entered at the keyboard is transmitted to the host computer. Data received from the host computer is displayed on the monitor. A local-echo feature (also selectable in Set-Up) routes data entered at the keyboard to the monitor as well as to the host computer.

On-Line Edit

The On-Line Edit state is selected while in Set-Up, and is used to let the terminal communicate with a host computer. When the terminal is on-line in this state, data entered at the keyboard is displayed directly on the monitor and transmitted to the host in block form, upon operator or host computer request. Prior to transmission the data displayed on the screen can be edited using the keyboard edit keypad. Data received from the host computer is displayed on the monitor.

When the terminal communications port is set to modem mode, the off-line state can be entered by pressing the Data/Talk Key. This disables communication with host computer. The terminal exits from the offline state after "togglng" the Data/Talk key, and establishing a connection.

OPERATING MODES

The VT225 has the following operating modes. Each is selectable while in Set-Up.

- o VT200 Mode, 7-Bit Controls
- o VT200 Mode, 8-Bit Controls
- o VT100 Mode
- o VT52 Mode

VT200 Mode, 7-Bit Controls

This mode executes standard ANSI functions and provides use of the full range of VT225 capabilities. It should be used when the VT225 is used with application programmes that expect 7-bit control characters and the ASCII component of the DEC multinational characters (European).

NOTE: In general, most VT100 application programmes will run in VT200 Mode, 7-Bit Controls.

VT200 Mode, 8-Bit Controls

This mode executes standard ANSI functions and provides use of the full range of VT225 capabilities. It should be used when the VT225 is used with application programmes that expect 8-bit control characters and the full DEC multinational characters (European).

National Replacement Character Sets

In addition to the 8-bit multinational character set, the VT225 terminal has a group of eleven 7-bit character sets. These character sets are national replacement character sets (NRC sets). You can select the multinational character set and the NRC sets in set-up by selecting a character set mode.

The VT225 has two basic character set modes, multinational and national.

Multinational mode supports the DEC multinational character set (DEC MCS). The DEC MCS is an 8-bit character set that contains most characters used in the major European languages. The ASCII character set is included in the DEC MCS.

National mode supports the national replacement character sets (NRC sets). The NRC sets are a group of eleven 7-bit character sets. The national character set available depends on the keyboard selected in set-up. Only one national character set is available for use at any one time. National mode restricts compatibility to a 7-bit environment where the use of the DEC MCS is disabled.

The keyboard maps in Appendix C of this manual show all the keys available on each national keyboard.

VT100 Mode

VT100 Mode executes standard ANSI functions. This mode should be used when the VT225 is used with application programmes that require strict compatibility with DIGITAL's VT100 terminal.

VT52 Mode

VT52 Mode is a text mode that executes DIGITAL private functions (not ANSI). It should be used for compatibility with existing application programmes designed for DIGITAL's VT52 terminal.

CRT SAVER FEATURE

If during normal operation there is no keyboard activity or input from a host computer for 30 minutes, the monitor screen goes blank (no data is lost). Activity from the keyboard or input from the host computer activates the monitor again. The recommended method for reactivating the screen is to press the "Ctrl" key.

COLOUR ON THE VT225

The VT225 is capable of displaying 64 different colours.

The colours are grouped into Palettes. There are Eight palettes available:-

- ANSI Colour - Colours following the ANSI control sequence standard.
- User Definable - Colours selected by the terminal user.
- VT241 Colour - Emulation of a Digital VT241 terminal in colour mode.
- VT241 Colour & Monochrome - Emulation of a Digital VT241 terminal in Colour and monochrome mode.
- 3279 Base Colour - Emulation of the colours used in a 3279 terminal
- Green Monochrome - Emulation of the VT220 terminals.
- Amber Monochrome - with different display
- White Monochrome - colours.

The user chooses a palette in setup mode from the Display Set-up Screen.

The Colour Set-up screen is used to change the colours if the user definable palette is selected, see Chapter 4.

THE VT225 STATUS LINE

The 25th line of the VT225 display is available for a Status line.

The user can select what is displayed on the 25th line by pressing the SHIFT and FIND keys together. The choices available are:

THE VT225 STATUS LINE CONT'D

No Status Lines - Status line is blank.

Indicator Status Line - The Status line displays information about the VT225 terminal.

Host Writable Status Line - The Status line shows information written by the Host Computer.

The VT225 Programmers Reference Manual describes how the host can switch the 25th Status line display.

PRINTING

The VT225 has a built-in serial printer interface that supports the following optional printers.

- | | |
|-------------|---------|
| o LA34/38 | o LA50 |
| o LA35/LA36 | o LQP02 |
| o LA12 | o LN03 |
| o LA100 | o LA75 |
| o LA120 | o LA210 |

The VT225 printing functions operate in one of four modes selected in Set-Up.

MODE	SET-UP SCREEN
Normal Mode	Printer Set-Up
Auto Print Mode	Printer Set-Up
Printer Controller Mode	Printer Set-Up
Local Controller Mode	Set-Up Directory and Printer Set-Up

These modes allow the terminal to perform several print operations selected from the keyboard and/or the computer.

The printer port can also be set up as an auxillary port.

This allows a host computer to communicate bidirectionally with the device connected to the printer port.

Normal Mode

Normal Print mode (default), allows all keyboard printing functions (such as Print Screen) to be invoked from the keyboard.

Auto Print Mode

When the VT225 is set to On-Line interactive state the Auto Print mode prints the current display line when the cursor moves to the next line. The cursor moves to the next line when the terminal receives a linefeed, form feed, vertical tab code or during auto wrap. When invoked, Auto Print mode is indicated on the indicator status line and in Set-Up. All keyboard printing functions (such as Print Screen) are allowed in Auto Print mode.

To invoke the Auto Print mode from the keyboard, type Ctrl-Print Screen. To exit the Auto Print mode, type Ctrl-Print Screen again.

When the VT225 is set to On-Line-Edit state, Auto Print mode is disabled.

Printer Controller Mode

In Printer Controller mode, the host computer has direct control of the printer. Characters received from the host computer go directly to the printer, and are not displayed on the screen (see Chapter 5, Printer Port Operating Modes). When invoked, Printer Controller mode is indicated on the indicator status line and in Set-Up. This mode cannot be invoked from the keyboard (except by entering Set-Up).

Printer Controller mode does not allow the use of local printing functions. For example, "Print Screen" does not work.

Printer Port Mode

The Printer Port Mode of the VT225 is identically to the Printer Port on the VT220 and VT22Z. Characters can be sent to the printer for printing. The VT225 accepts XON and XOFF from the printer for flow control, but discards all other characters received from the printer.

Applications Port Mode

In Applications Port Mode the printer port becomes bi-directional. Characters from the printer (other than XON and XOFF) are sent to the Host Computer, as if they had been entered from the keyboard.

Characters from the keyboard are interspaced with characters from the printer, except that ANSI control Sequences from the printer will not be split unless they are more than 200 characters long.

Controller Mode

Local Controller mode is a special mode that is derived by invoking two separate and distinct Set-Up features.

1. Local - invoked in Set-Up Directory.
2. Printer Controller Mode - invoked in Printer Set-Up.

When these two Set-Up features are selected, the terminal is said to be in Local Controller mode. Local controller mode is used to allow keyboard output to the printer. This may be useful in setting up certain printers for operation, without involving the host computer.

COMPOSING CHARACTERS

You can use "compose sequences" to create characters that do not exist as standard keys on your keyboard. There are two types of compose sequences: three-stroke sequences and two-stroke sequences.

Three-stroke sequences can be used on all keyboards. They are performed by first pressing the Compose Character key then pressing two standard keys whose characters form a valid sequence.

Two-stroke sequences can be used on all keyboards except the North American keyboard. Two-stroke sequences do not use the Compose Character key. Although faster to use than the three-stroke sequence, two-stroke sequences are limited to sequences starting with the following non-spacing diacritical marks: grave accent, acute accent, circumflex accent, tilde mark, diaeresis mark (umlaut) and ring mark. Instead of using the Compose Character key, as in a three-stroke sequence, you use a "non-spacing diacritical" mark to initiate the two-stroke sequence. You then enter a standard character that, together with that diacritical mark, results in a valid compose sequence.

Diacritical marks are available on all but the North American keyboard. The diacritical marks vary among the keyboards according to the relative usage of characters with diacritical marks. Also, only one of several characters shown on a keycap may be a diacritical mark, meaning some keyboards have keys that contain both a standard character and a diacritical mark.

As with standard keys, you select the character you want with the Shift and Lock keys.

If a diacritical mark is used within a three-stroke sequence, the diacritical mark is treated as if it were its equivalent character, defined as follows:

Diacritical Mark	Equivalent Character
Diaeresis (umlaut) mark	Double quote "
Acute accent	Apostrophe '
Grave accent	Single quote `
Circumflex accent	Circumflex character ^
Tilde mark	Tilde character ~
Ring mark	Asterisk * or degree °

All valid compose sequences are listed in Table 3-1 and 3-2. Because of keyboard differences, characters listed in Column 1 may be created in one or more ways:

- o With a standard key (if available on that keyboard)
- o With a three-stroke compose sequence (always)
- o With a two-stroke compose sequence (if the diacritical mark is available on the keyboard)

Using a Three-Stroke Compose Sequence

Following this procedure to use a three-stroke compose sequence.

1. Locate in Column 1 of Table 3-1 the character you want to create.
2. Press the Compose Character key (the Compose indicator starts blinking indicating the terminal is in "compose" mode).
3. Type the two characters from Column 2 for the character you want to create.

For example, to create e with acute accent, press Compose Character, and then type e and apostrophe; or press Compose Character, and then type apostrophe and e.

When a valid sequence is completed, the Compose indicator turns off, and the resultant character is sent to the application. If you use an invalid sequence, the sequence is aborted and the bell sounds (if Bell is enabled in Keyboard Set-Up).

NOTE: Function keys will abort a compose sequence without sounding the bell.

Table 3-1 Valid Compose Sequences

In three-stroke sequences, the order in which required characters are entered does not matter unless otherwise stated. All two-stroke sequences are order sensitive.

(1) Resultant Character	Characters Required in Sequence	
	(2) Three-Stroke Sequence	(3) Two-Stroke Sequence
" (quotation mark)	" (sp)	" (sp)
# (number sign)	++	
~ (apostrophe)	' (sp)	' (sp)
@ (commercial at)	a a or A A	
[(opening bracket)	((
\ (backslash)	// or /<	
] (closing bracket))	
^ (circumflex)	^ (sp)	^ (sp)
' (single quote)	' (sp)	' (sp)
{ (opening brace)	(-	
(vertical line)	/^	
} (closing brace))-	
~ (tilde)	~ (sp)	~ (sp)
! (inverted !)	!!	
¢ (cent sign)	c/ or C/ or c or C	
£ (pound sign)	l- or L- or l= or L=	
¥ (yen sign)	y- or Y- or y= or Y=	
§ (section sign)	so or SO or S! or s! or s0 or S0	
¤ (currency sign)	xo or XO or xo Or X0	

Table 3-1 Valid Compose Sequences (Cont)

		<u>Characters Required in Sequence</u>	
(1) Resultant Character		(2) Three-Stroke Sequence	(3) Two-Stroke Sequence
©	(copyright sign)	co or CO or c0 or C0	
ª	(feminine ordinal indicator)	a_ or A_	
«	(angle quotation mark left)	<<	
°	(degree sign)	0^ or (sp)* or (sp) o	o (sp)
±	(plus/minus sign)	+-	
²	(superscript 2)	2^	
³	(superscript 3)	3^	
μ	(micro sign)	/u or /U (order sensitive)	
¶	(paragraph sign)	p! or P!	
.	(middle dot)	.^	
¹	(superscript 1)	1^	
º	(masculine ordinal indicator)	o_ or O_	
»	(angle quotation mark right)	>>	
¼	(fraction one-quarter)	1 4 (order sensitive)	
½	(fraction one-half)	1 2 (order sensitive)	
¿	(inverted ?)	??	
À	(A grave)	A^	˘A
Á	(A acute)	A'	'A
Â	(A circumflex)	A^	ˆA
Ã	(A tilde)	A~	˜A
Ä	(A umlaut)	A" or A**	¨A

Table 3-2 Valid Compose Sequences: National Mode (Cont)

(1) Composite Character	Characters Required in Sequence	
	(2) Three-Stroke Sequence	(3) Two-Stroke Sequence
<u>French/Belgian Keyboard</u>		
£ (pound sign)	-L or -l or =L or =l	
§ (section)	!s or !S or os or oS or Os or OS or 0s or 0S	
è (e grave)	`e	
ù (u grave)	'u.	
<u>Spanish Keyboard</u>		
£ (pound sign)	-L or -l or =L or =l	
§ (section)	!s or !S or os or oS or Os or OS or 0s or 0S	
¡ (inverted !)	! !	
¿ (inverted ?)	? ?	
° (degree sign)	^ o	

Table 3-1 Valid Compose Sequences (Cont)

		<u>Characters Required in Sequence</u>	
(1) Resultant Character		(2) Three-Stroke Sequence	(3) Two-Stroke Sequence
Ü	(U umlaut)	U" or U"	..U
ÿ	(Y umlaut)	Y" or Y"	..Y
ß	(German small sharp s)	ss	
à	(a grave)	a`	`a
á	(a acute)	a'	'a
â	(a circumflex)	a^	^a
ã	(a tilde)	a~	~a
ä	(a umlaut)	a" or a"	..a
å	(a ring)	a* or a ^o (degree sign)	o a
æ	(a e ligature)	a e (order sensitive)	
ç	(c cedilla)	c , (comma)	
è	(e grave)	e`	`e
é	(e acute)	e'	'e
ê	(e circumflex)	e^	^e
ë	(e umlaut)	e" or e"	..e
ì	(i grave)	i`	`i
í	(i acute)	i'	'i
î	(i circumflex)	i^	^i
ï	(i umlaut)	i" or i"	..i
ñ	(n tilde)	n~	~n
ò	(o grave)	o`	`o
ó	(o acute)	o'	'o

Table 3-1 Valid Compose Sequences (Cont)

(1) Resultant Character	Characters Required in Sequence	
	(2) Three-Stroke Sequence	(3) Two-Stroke Sequence
ô (o circumflex)	o^	^o
õ (o tilde)	o~	~o
ö (o umlaut)	o" or O^^	^^o
œ (o e ligature)	o e (order sensitive)	
ø (o slash)	o/	
ù (u grave)	u`	`u
ú (u acute)	u'	'u
û (u circumflex)	u^	^u
ü (u umlaut)	u" or u^^	^^u
ÿ (y umlaut)	y" or y^^	^^y

Compose Sequences for National Mode

The NRC character sets expand the range of valid two- and three-stroke compose sequences. The following table lists all the compose sequences available in national mode.

NOTE: The validity of each compose sequence depends on the terminal's present character set mode (multinational or national). In national mode, the validity of each compose sequence depends on the national keyboard in use.

Table 3-2 Valid Compose Sequences: National Mode

In three-stroke sequences, you can enter required characters in any order unless the table says "order sensitive". You must enter all two-stroke sequences in the order shown.

(1) Composite Character	Characters Required in Sequence	
	(2) Three-Stroke Sequence	(3) Two-Stroke Sequence
<u>British Keyboard</u>		
£ (pound sign)	l- or L- or l= or L=	
/ (backslash)	/<	
<u>Flemish Keyboard</u>		
£ (pound sign)	-L or -l or =L or =l	
§ (section)	!s or !S or os or oS or Os or OS or øS or øS	
ù (u grave)	~u	
è (e grave)	~e	

Table 3-2 Valid Compose Sequences: National Mode (Cont)

(1) Composite Character	<u>Characters Required in Sequence</u>	
	(2) Three-Stroke Sequence	(3) Two-Stroke Sequence
<u>French Canadian Keyboard</u>		
à (a grave)	`a	`a
â (a circumflex)	^a	^a
ç (c cedilla)	'c	
ê (e circumflex)	^e	^e
è (e grave)	`e	`e
î (i circumflex)	^i	^i
ô (o circumflex)	^o	^o
ù (u grave)	`u	`u
û (u circumflex)	^u	^u
<u>Danish Keyboard</u>		
# (number sign)	++	
Ä (A umlaut)	``A	``A
Å (A ring)	*A	
Ø (O slash)	O/	
Ü (U umlaut)	``U	``U
ä (a umlaut)	``a	``a
å (a ring)	*a	
ø (o slash)	o/	
ü (u umlaut)	``u	``u

Table 3-2 Valid Compose Sequences: National Mode (Cont)

(1) Composite Character	Characters Required in Sequence	
	(2) Three-Stroke Sequence	(3) Two-Stroke Sequence
<u>Finnish Keyboard</u>		
# (number sign)	++	
@ (commercial at)	aa or AA or aA	
Å (A ring)	*A	
Ü (U umlaut)	"U	
é (e acute)	'e	
å (a ring)	*a	
ü (u umlaut)	"u	
<u>German Keyboard</u>		
Ä (A umlaut)	..A	
Ü (U umlaut)	..U	
ä (a umlaut)	..a	
ü (u umlaut)	..u	

Table 3-2 Valid Compose Sequences: National Mode (Cont)

(1) Composite Character	Characters Required in Sequence	
	(2) Three-Stroke Sequence	(3) Two-Stroke Sequence
<u>Dutch Keyboard</u>		
£ (pound sign)	-L or -l or =L or =l	
3/4 (three quarters)	3 4 (order sensitive)	
ÿ (i j sign)	i j (order sensitive)	
½ (one half)	1 2 (order sensitive)	
Florin	f- (order sensitive)	
<u>Italian Keyboard</u>		
£ (pound sign)	-L or -l or =L or =l	
§ (section)	!s or !S or os or oS or Os or OS or 0s or 0S	
à (a grave)	`a	
ç (c cedilla)	,c	
é (e acute)	'e	

Table 3-2 Valid Compose Sequences: National Mode (Cont)

(1) Composite Character	Characters Required in Sequence	
	(2) Three-Stroke Sequence	(3) Two-Stroke Sequence
<u>Swiss (French) Keyboard</u>		
ä (a umlaut)	``a	
ç (c cedilla)	,c	
ê (e circumflex)	^e	^e
î (i circumflex)	^i	^i
ô (o circumflex)	^o	^o
ö (o umlaut)	``o	
û (u circumflex)	^u	^u
ü (u umlaut)	``u	
ù (u grave)	`u	`u
<u>Swiss (German) Keyboard</u>		
à (a grave)	`a	`a
ç (c cedilla)	,c	
ê (e circumflex)	^e	^e
é (e acute)	'e	
è (e grave)	`e	`e
î (i circumflex)	^i	^i
ô (o circumflex)	^o	^o
û (u circumflex)	^u	^u
ù (u grave)	`u	`u

Table 3-2 Valid Compose Sequences: National Mode (Cont)

(1) Composite Character	<u>Characters Required in Sequence</u>	
	(2) Three-Stroke Sequence	(3) Two-Stroke Sequence
<u>Swedish Keyboard</u>		
# (number sign)	++	
Å (A ring)	*A	
É (E acute)	'E	
Ü (U umlaut)	"U	
å (a ring)	*a	
é (e acute)	'e	
ü (u umlaut)	"u	
<u>Norwegian Keyboard</u>		
# (number sign)	++	
Å (A ring)	*A	
Ä (A umlaut)	``A	``A
Æ (A E dipthong)	A E (order sensitive)	
Ü (U umlaut)	``U	``U
ä (a umlaut)	``a	``a
æ (a e dipthong)	a e (order sensitive)	
å (a ring)	*a	
ü (u umlaut)	``u	``u

Table 3-1 Valid Compose Sequences (Cont)

		<u>Characters Required in Sequence</u>	
(1) Resultant Character		(2) Three-Stroke Sequence	(3) Two-Stroke Sequence
À	(A ring)	A* or Ao (degree sign)	A
Æ	(A E ligature)	AE (order sensitive)	
Ç	(C cedilla)	C,	
È	(E grave)	E`	~E
É	(E acute)	E'	'E
Ê	(E circumflex)	E^	^E
Ë	(E umlaut)	E" or E''	''E
Ì	(I grave)	I`	~I
Í	(I acute)	I'	'I
Î	(I circumflex)	I^	^I
Ï	(I umlaut)	I" or I''	''I
Ñ	(N tilde)	N~	~N
Ò	(O grave)	O`	~O
Ó	(O acute)	O'	'O
Ô	(O circumflex)	O^	^O
Õ	(O tilde)	O~	~O
Ö	(O umlaut)	O" or O''	''O
Œ	(O E ligature)	O E (order sensitive)	
Ø	(O Slash)	O/	
Ù	(U grave)	U`	~U
Ú	(U acute)	U'	'U
Û	(U circumflex)	U^	^U

Using a Two-Stroke Sequence

Follow this procedure to use a two-stroke compose sequence.

NOTE: Two-stroke compose sequences are possible on all keyboards except the North American keyboard.

1. Locate in Column 1 of Table 3-1 the character you want to create and verify from Column 3 that the character can be created.
2. Press the key with the diacritical mark shown in Column 3 (the Compose indicator blinks to indicate the terminal is in "compose" mode).
3. Type the second character shown in Column 3.

For example, to create e with a grave accent on a Danish keyboard, press the key that has the grave accent and then type e.

When a valid sequence is completed, the Compose indicator turns off, and the resultant character is sent to the application. If you use an invalid sequence, the sequence is aborted and the bell sounds (if Bell is enabled in Keyboard Set-Up).

NOTE: Function keys will abort a compose sequence without sounding the bell.

Aborting or Restarting a Compose Sequence

If you enter compose mode inadvertently either by pressing the Compose Character key or a diacritical mark key, press the <X] (Delete) key to immediately terminate the compose sequence and exit compose mode. No character is sent to the application.

If you press the Compose Character key during a compose sequence, a new three-stroke sequence is started from that point. The previous sequence is aborted with no affect on the application.

LOCAL EDITING - GENERAL

The on-line local editing mode of the VT225 allows the operator to enter and modify data without host involvement. This capability is further enhanced by the multipage operation of the VT225.

The terminal is placed into edit mode by pressing SHIFT/GOLD or SHIFT/PF1. This key combination is also used to exit edit mode. When in edit mode the keyboard COMP (EDIT) LED is illuminated.

Editing Keys - Display Movement

The keys that can be used in edit mode to move the display up or down and their actions are described below.

Key	Action
SHIFT/UP Arrow	The display scrolls up one line
SHIFT/DOWN Arrow	The display scrolls down one line
SHIFT/LEFT Arrow	The display switches to the previous page *
SHIFT/RIGHT Arrow	The display switches to the next page *
PREV PAGE	The display switches to the previous page *
NEXT PAGE	The display switches to the next page *
CNTRL/LEFT Arrow	The display switches to the first page
CNTRL/RIGHT Arrow	The display switches to the last page

Note: * If a completely new page cannot be displayed, the audible bell is rung.

Editing Keys - Cursor Movement

The keys that can be used in edit mode to move the cursor position are as follows.

Key	Action
Up Arrow	Cursor moves up one line until the top margin
Down Arrow	Cursor moves down one line until the bottom margin
Left Arrow	Cursor moves to the left one position until the left margin
Right Arrow	Cursor moves to the right one position until the right margin
Tab	Cursor moves to the right and down-wards until one of the following: <ul style="list-style-type: none">o an unprotected tab positiono the start of an unprotected fieldo the bottom right margin
Back Tab	Cursor moves to the left and upwards until one of the following: <ul style="list-style-type: none">o an unprotected tab positiono the start of an unprotected fieldo the top left margin
Home	Cursor moves to the top left hand margin of the display

Editing Keys - Display Modification

Typing any visible character in edit mode will cause that character to be stored at the cursor position, provided that the position is unprotected. If it is protected, the bell will ring and the cursor will move to the next unprotected position on the display and the character will be stored at that position. If none exists, the bell will ring with the cursor at the bottom right margin.

The following function keys will also modify the display.

Key	Action
Delete	The character to the left of the cursor is deleted.
Erase Field	Starting from the cursor position, the current unprotected field is erased. If the cursor is on a protected position, this key has no effect on the display.
Select	Marks the start of a REMOVE operation. The area between this position and subsequent cursor position will be shown in reverse video. The bell will ring when the cursor is subsequently moved over a protected character, indicating an invalid select. The last character of a select may be protected but will not be removed. Note: The Select-Remove operation is disabled when DECPRO, protection by reverse video, is used.
Shift/Select	Cancels the effect of a SELECT without modifying the display.
Remove	The characters (except the last one) highlighted by reverse video will be deleted and the display moved to the left and upwards.
Note:	The last position covered by the reverse video is not deleted, irrespective of the position of the select marker.

Key	Action
Clear (Shift/Home)	All the unprotected characters on the visible display are deleted. The cursor moves to the first unprotected position.
Insert Here	Puts the terminal into insert mode. Characters typed will not replace characters in unprotected fields but will push them to the right. Characters moved into the right margin or a protected field will be lost.
Shift/INSERT HERE	Puts the terminal into replace mode. Characters typed will replace the previous unprotected characters.

Note: In insert mode, new lines can be inserted by the Return key, except when the cursor is on the bottom line of the display. Lines pushed down in this mode will be scrolled out to display memory until either the end of memory or a line with a protected field is reached.

GENERAL

This Chapter describes VT225 Set-Up, and how to use it to examine or change terminal operating features such as Colour, transmit/receive speeds, type of cursor, and so on.

The VT225 stores many of its operating features in an NVR (Non Volatile RAM) memory, that retains these features even when power is shut off. In addition to storing operator selected features, the terminal also retains the factory default settings which can be recalled in Set-Up.

All available Set-Up features can be changed from the keyboard, while some can be changed by the host computer as described in the VT225 Programmer's Reference Manual (see Appendix B).

USING SET-UP

Set-Up is based on selectable displays called "Set-Up Screens". Any Set-Up screen can be selected from the Set-Up Directory Screen which is displayed when you enter Set-Up (Figure 4-1). Each Set-Up screen displays the information particular to that Set-Up function and allows you to change or retain those features. Only one Set-Up screen can be displayed at a time. You can enter the Set-Up Directory Screen from any Set-Up screen.

SET-UP SCREENS

Each Set-Up screen occupies the monitor display (current screen data is temporarily invisible). No incoming data is lost if the host supports XOFF and that feature is enabled (see Communication Set-Up). Each screen contains the following information (example, Figure 4-2).

- o Screen title
- o Terminal identifier
- o Firmware version number
- o Status line
- o Fields (Action, Parameter, Text Parameter)

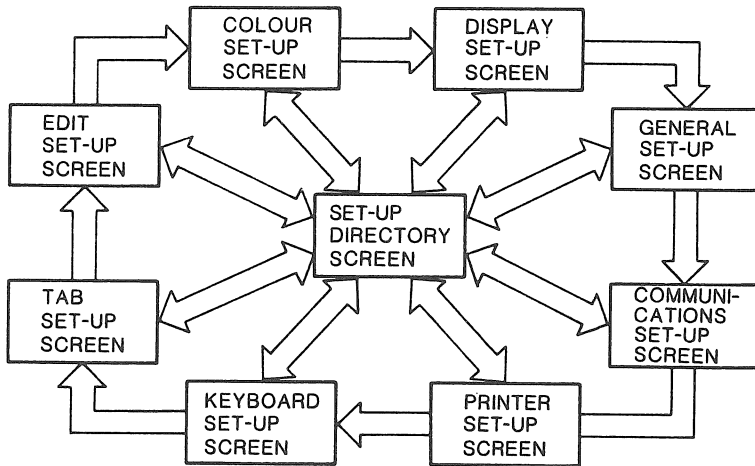

SN-0008-87

Figure 4-1 Set-Up Screens

Display Set-Up VT225-V1.0

To Next Set-Up To Directory 80 Columns Interpret Controls

No Auto Wrap Smooth Scroll Foreground Text, Background Screen

Cursor Block Cursor Style, Blinking 60 Hz

ANSI Colour No Status Line

Replace Mode Printer: None

SN-0012-87

Figure 4-2 Sample Set-Up Screen

Screen Title

The Screen title identifies the current Set-Up screen. There are nine Set-Up screens.

1. Set-Up Directory
2. Display Set-Up
3. General Set-Up
4. Communications Set-Up
5. Printer Set-Up
6. Keyboard Set-Up
7. Tab Set-Up
8. Edit Set-Up
9. Colour Set-Up

Terminal Identifier

The terminal identifier identifies the type of terminal being used; in this case a VT225.

Firmware Version Number

The firmware version number identifies the level of firmware the terminal is using.

Set-up Status Line

The indicator status line is always shown at the bottom of each Set-Up screen. It shows you the current status of the modem (if modem control is selected), the printer, and the terminal insert/replace mode. The status line is a reporting line only, you cannot interact with it via the keyboard. Table 4-1 describes the status line messages.

Table 4-1 Set-up Status Line Messages

Report	Values	Meaning
Insert/ Replace:	Insert	The terminal is in Insert mode. All new display characters, during normal text operation, move old characters to the right; old characters moved past the right margin are lost.
	Replace	The terminal is in Replace mode. All new display characters, during normal text operation, replace old characters at the cursor position. Replace is the normal mode of operation.
Printer:	Ready	The printer is ready.
	Not Ready	The printer is not ready.
	None	No printer available.
	Auto	The terminal is in Auto Print mode.
	Controller	The terminal is in Printer Controller mode.
Modem:	Talk	The terminal is in offline mode and requesting the modem to stay in TALK mode.
	No DSR	The modem is not ready.
	DSR	The modem is ready to send or receive, but no carrier has been detected by the modem.
	DSR, Connected	The modem is connected to a remote modem and ready to communicate.

Fields

The fields on each screen are blocks of text describing current operating characteristics. There are three types of fields:

1. Action Field

An action field always reads the same since it has only one value. When an action field is selected, and the Enter key is pressed, the action is performed.

For example, each screen has an action field that reads "To Directory". Invoking this field replaces the current screen with the Set-Up Directory Screen when you press the Enter key.

2. Parameter Field

A parameter field contains self-describing text that has two or more values. When a parameter field is selected, pressing the Enter key results in replacing the current value of the field with the next value.

For example, if the Keyclick parameter field is selected, it may have the current value of "Keyclick". Pressing the Enter key results in the field changing to "No Keyclick".

3. Text Parameter Field

In text parameter fields direct entry of text is accomplished by typing the value from the keyboard. Use the following procedure when selecting a text parameter field.

1. Use the arrow keys to position the field cursor on the text parameter field (see Set-Up Controls and Cursor).
2. Press the Enter key. The terminal prompts you for text entry on the Set-up "status line" at the bottom of the screen, temporarily overwriting the Set-up Status line.
3. Type the text you want entered as the new value. The value is echoed back next to the prompt.
4. Press the Enter key to enter the new value.

If you make a mistake, press the <X>(Delete) key to erase the last character entered. If you want to abort the entry without change to the original value, press an Arrow key to change the field selection (see Set-Up Controls and Cursor).

Set-Up Controls and Cursor

The VT225 uses a "field cursor" while in Set-Up. The field cursor is displayed as a highlighted field that can be moved from field to field using the keyboard arrow keys.

The controls used to enter and exit Set-Up, move the field cursor, and change operating characteristics are described in Table 4-2.

Table 4-2 Set-Up Controls and Cursor Functions

Control Key	Function
Set-Up	Alternately pressing the Set-Up key places the terminal in Set-Up, or returns it to the operating state (On-Line or Local).
Arrow Keys	Pressing the arrow keys moves the field cursor in the direction of the arrow.
Enter	The Enter key is used to activate the function at the field cursor position. If an action field is selected, pressing Enter causes the described action to be performed. If a parameter field is selected, pressing Enter changes the value of the field. The Enter key can be used to "toggle" through the range of field values. The value displayed at any given time is the current value invoked.

EXAMPLE SET-UP PROCEDURE

This section provides an example procedure for changing the terminal operating characteristics using Set-Up.

Suppose that the terminal is currently set to display its text in 80 columns, and the keyboard keys "click" each time the keys are pressed.

Suppose further, that you want to change these two operating characteristics so the terminal will display 132 columns, and the keyboard keys will not "click" each time they are pressed.

Use the following procedure to change these two operating characteristics in Set-Up.

1. Press the Set-Up key. The terminal enters Set-Up and displays the Set-Up Directory Screen (see Figure 4-3).
2. Note that the cursor is on the field that reads "Display".
3. Press the Enter key. The terminal replaces the Directory Set-Up screen with the Display Set-Up screen (see Figure 4-4).
4. Use the arrow keys to position the field cursor on the field that reads "80 columns".
5. Press the Enter key. The field changes from "80 columns" to "132 columns" indicating that the feature changed.

NOTE: Although many parameter changes are immediate (such as the "column" feature), some changes do not take effect until Set-Up is exited.

6. Use the arrow keys to position the field cursor on the field that reads "Directory" (we want to change another characteristic).
7. Press the Enter key. The terminal replaces the Display Set-Up screen with the Directory Set-Up screen.

8. Use the arrow keys to position the field cursor on the field that reads "Keyboard".
9. Press the Enter key. The terminal replaces the Directory Set-Up screen with the Keyboard Set-Up screen (Figure 4-8).
10. Use the arrow keys to position the field cursor on the field that reads "Keyclick".
11. Press the Enter key. The field changes from "Keyclick" to "No Keyclick" indicating that the feature changed.
12. Press the Set-Up key to exit Set-Up and return to the operating mode (On-Line or Local).

SET-UP SCREEN SUMMARIES

The following sections describe the Set-Up Screens and their associated features. As you select the various set-up features you are going to use, be sure to check off the box beside the parameter value selected for that feature. This gives you a record of the values selected in case the settings are inadvertently changed or lost. If repairs to the terminal are necessary, the technician will need this information to reset the set-up feature values.

Table 4-2A summarizes the Set-Up Screens. It lists the features available on each screen.

Table 4-2A Set-Up Display Summary

<u>Set-Up Directory</u>	<u>Display Set-Up</u>	<u>General Set-Up</u>
<u>Display Set-Up</u>	<u>To Next Set-Up</u>	<u>To Next Set-Up</u>
General Set-Up	To Directory	To Directory
Communications Set-Up	80/132 Columns	Terminal Mode
Printer Set-Up	Control Representation	Terminal ID
Keyboard Set-Up	Mode	UDK Lock
Tab Set-Up	Auto Wrap	UDK Shift
Edit Set-Up	Smooth/Jump Scroll	User Features Lock
Colour Set-Up	Light/Dark Screen	Character Set Mode
On-Line/Local	Cursor	Keypad Mode
Clear Display	Cursor Style	Cursor Key Mode
Clear Communications	50/60 Hz Frame rate	New Line Mode
Reset Terminal	Colour Palette	
Recall Saved Parameters	Status Line Mode	
Save Parameters		
Set-Up Language		
Keyboard Language		
Default		
Exit Set-Up		
<u>Communications Set-Up</u>	<u>Printer Set-Up</u>	<u>Keyboard Set-Up</u>
<u>To Next Set-Up</u>	<u>To Next Set-Up</u>	<u>To Next Set-Up</u>
To Directory	To Directory	To Directory
Transmit Speed	Transmit/Receive Speed	Typewriter/D.P.
Receive Speed	Port Mode	Caps/Shift-Lock
XOFF	Print Mode	Auto Repeat
Data-Bits/Parity	Data-Bits/Parity	Keyclick
Stop Bits	Stop Bits	Margin Bell
Local Echo	Print Page/Region	Warning Bell
Host Port Selection	Printed Data Type	Break
Disconnect	Print Terminator	Auto Answerback
Transmit Rate Limit		Answerback Text
		Conceal Answerback
<u>Tab Set-Up</u>	<u>Edit Set-Up</u>	<u>Colour Set-Up</u>
<u>To Next Set-Up</u>	<u>To Next Set-Up</u>	<u>To Next Set-Up</u>
To Directory	To Directory	To Directory
Clear All Tabs	Interactive	Default Colours
Set 8 Column Tabs	Edit Key =	Change Colour
Tab Fields and Ruler	Erase All	Colour Components
	Full Page Transmit	
	Immediate Transmit	
	Transmit All	
	Space Compression	
	EOL Terminator	

SET-UP DIRECTORY SCREEN

The Set-Up Directory screen (Figure 4-3) is displayed immediately upon entering Set-Up. This screen lets you access any other Set-Up Screen and it also contains fields you can use to select terminal operating characteristics.

All fields on this screen are described in Table 4-3.

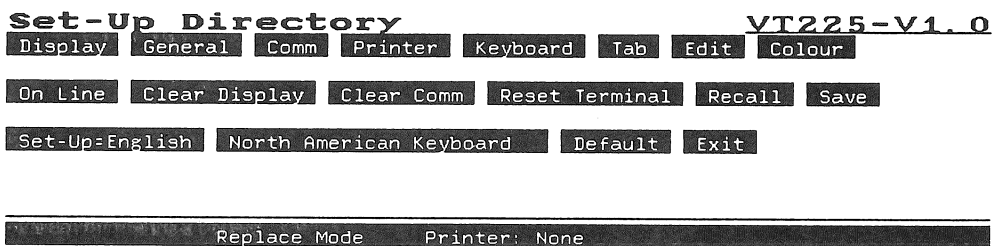

SN-0013-87

Figure 4-3 Set-Up Directory

Table 4-3 Set-Up Directory Screen

Field	Function
Display	Replaces the Set-up Directory screen with the Display Set-up screen.
Action field	
Value: Display	
General	Replaces the Set-up Directory screen with the General Set-up screen.
Action field	
Value: General	

Table 4-3 Set-Up Directory Screen (Cont)

Field	Function
Comm Action field Value: Comm	Replaces the Set-up Directory screen with the Communications Set-up screen.
Printer Action field Value: Printer	Replaces the Set-up Directory screen with the Printer Set-up screen.
Keyboard Action field Value: Keyboard	Replaces the Set-up Directory screen with the Keyboard Set-up screen.
Tab Action field Value: Tab	Replaces the Set-up Directory screen with the Tab Set-up screen.
Edit Action field Value: Colour	Replaces the Set-up Directory screen with the Edit Set-up screen.
Colour Action field Value: Colour	Replaces the Set-Up Directory screen with the Colour Set-Up screen.

Table 4-3 Set-Up Directory Screen (Cont)

Field	Function
On-Line or Local Parameter field	On-Line lets the terminal communicate with the host computer. Local effectively puts the host computer on "hold". Data entered at the keyboard is sent directly to the monitor screen only.
Values:	
	<input type="checkbox"/> On-Line (default) <input type="checkbox"/> Local
Clear Display Action field Value: Clear Display	Clears the monitor screen when Set-up is exited.
Clear Comm Action field Value: Clear Comm	Clears the following communications items: Aborts any print operation in progress. Aborts any escape sequence, control sequence or DCS processing. Clears the keyboard buffers. Clears the receive buffer. Clears the transmit buffer. Takes the terminal out of printer controller mode. Sends XON to the host port. Resets XOFF received flags on both ports (host and printer).

Table 4-3 Set-Up Directory Screen (Cont)

Field	Function
Reset Terminal	Resets many terminal operating features to a "known state" (default) used by most application programmes.
Action field	
Value: Reset Terminal	The Screen, Communication and User-Defined Keys are not affected.
Recall	Replaces all existing Set-Up characteristics with "saved" values. The monitor screen is cleared.
Action field	
Value: Recall	NOTE: Recall causes a disconnect to occur.
Save	Saves all Set-Up features in all Set-up screens.
Action field	
Value: Save	
Set-up= _____	Allows you to choose the language in which you want Set-up screens displayed.
Parameter field	
Values:	
	<input type="checkbox"/> Set-up = English
	<input type="checkbox"/> Mode de fonct. = Francais
	<input type="checkbox"/> Auswahlbild = Deutch

Table 4-3 Set-Up Directory Screen (Cont)

Field	Function
Keyboard	This field lets you select correct terminal operation for the national keyboard you are using.
Parameter field	
Values:	
	<input type="checkbox"/> North American
	<input type="checkbox"/> British
	<input type="checkbox"/> Flemish
	<input type="checkbox"/> Canadian (French)
	<input type="checkbox"/> Danish
	<input type="checkbox"/> Finnish
	<input type="checkbox"/> German
	<input type="checkbox"/> Dutch
	<input type="checkbox"/> Italian
	<input type="checkbox"/> Swiss (French)
	<input type="checkbox"/> Swiss (German)
	<input type="checkbox"/> Swedish
	<input type="checkbox"/> Norwegian
	<input type="checkbox"/> French/Belgian
	<input type="checkbox"/> Spanish
Default	Replaces all current Set-up features with factory default settings. The monitor screen is cleared and the cursor is returned to the upper-left corner of the screen.
Action field	
Value: Default	
	NOTE: Default causes a disconnect to occur.
Exit	Exits Set-Up and returns the terminal to On-Line or Local.
Action field	
Value: Exit	

DISPLAY SET-UP SCREEN

The Display Set-up screen (Figure 4-4) lets you define monitor display characteristics.

All fields on this screen are described in Table 4-4.

```
Display Set-Up VT225-V1.0  
To Next Set-Up To Directory 80 Columns Interpret Controls  
No Auto Wrap Smooth Scroll Foreground Text, Background Screen  
Cursor Block Cursor Style, Blinking 60 Hz  
ANSI Colour No Status Line  
-----  
Replace Mode Printer: None
```

SN-0012-87

Figure 4-4 Display Set-Up

Table 4-4 Display Set-Up Screen

Field	Function
To Next Set-Up Action field Value: To Next Set-up	Replaces the Display Set-up Screen with the General Set-up field.
To Directory Action field Value: To Directory	Replaces the Display Set-up Screen with the Set-up Directory screen.

Table 4-4 Display Set-Up Screen (Cont)

Field	Function
<p>_____ Columns</p> <p>Parameter field</p> <p>Values:</p> <p> <input type="checkbox"/> 80 Columns (default)</p> <p> <input type="checkbox"/> 132 Columns</p>	<p>Selects an 80 or 132 column display for text. A change to this field takes affect immediately and clears the display, and the DRCS character set.</p>
<p>_____ Controls</p> <p>Parameter field</p> <p>Values:</p> <p> <input type="checkbox"/> Interpret Controls (default)</p> <p> <input type="checkbox"/> Display Controls</p>	<p>Interpret Controls causes control codes received from the host computer to be interpreted but not displayed.</p> <p>Display Controls causes the terminal to display the control codes received from the host computer as characters, but not to act on them.</p>
<p>Auto Wrap</p> <p>Parameter field</p> <p>Values:</p> <p> <input type="checkbox"/> Auto Wrap</p> <p> <input type="checkbox"/> No Auto Wrap (default)</p>	<p>Auto Wrap causes a received character after the right margin to be automatically displayed in the first character position of the next line.</p> <p>No Auto Wrap causes received characters after the right margin to be overwritten into the last character position of the current line.</p>
<p>_____ Scroll</p> <p>Parameter field</p> <p>Values:</p> <p> <input type="checkbox"/> Smooth Scroll (default)</p> <p> <input type="checkbox"/> Jump Scroll</p>	<p>Smooth Scroll limits the speed at which new lines appear on the screen, causing a smooth steady scroll.</p> <p>Jump Scroll displays new lines as fast as they are received, causing a "jump" scroll.</p>

Table 4-4 Display Set-Up Screen (Cont)

Field	Function
<p>_____Text, _____Screen</p> <p>Parameter field</p> <p>Values:</p> <p><input type="checkbox"/> Foreground Text, Background Screen (default)</p> <p><input type="checkbox"/> Background Text, Foreground Screen</p>	<p>Selects a normal screen display (usually light text on a usually dark background) or reverse video screen display (dark text on a light background).</p> <p>If the user defined palette is selected the appearance of the screen will depend upon the settings of the foreground and background colours.</p>
<p>Text Cursor</p> <p>Parameter field</p> <p>Values:</p> <p><input type="checkbox"/> Cursor (default)</p> <p><input type="checkbox"/> No Cursor</p>	<p>Selects whether or not the text cursor is displayed.</p>
<p>_____Cursor Style</p> <p>Parameter field</p> <p>Values:</p> <p><input type="checkbox"/> Block Cursor, Blinking (default)</p> <p><input type="checkbox"/> Underline Cursor Style, Steady</p> <p><input type="checkbox"/> Underline Cursor Style, Blinking</p> <p><input type="checkbox"/> Block Cursor Style, Steady</p>	<p>Selects the text cursor style (block or underline) displayed, and selects if the cursor should blink or remain steady.</p>

_____ Hz

Selects the screen refresh rate.
60 Hz is recommended. In countries
using 50 Hz mains frequency, where there
is a high magnetic field the use of 50
Hz refresh may produce a more stable
display.

Parameter field

50 Hz

60 Hz (Default)

Colour Palette

Selects the combinations of colours used
on the screen.

Parameter field

Values: ANSI Colour (Default)

User Definable Palette

VT240 Colour

VT240 Colour and Monochrome

3279 Base Colour

Green Monochrome

Amber Monochrome

White Monochrome

Status Line

Selects the information displayed on the
25th line of the screen.

Parameter field

Values: No Status Line (Default)
Line is blank

Indicator Status Line
Displays cursor position,
printer and modem status

Host Writable Status Line
Written from the host computer

GENERAL SET-UP SCREEN

The General Set-up screen (Figure 4-5) lets you define a group of commonly used general operating features.

All fields on this screen are described in Table 4-5.

```
General Set-Up VT225-V1.0
To Next Set-Up To Directory VT200 Mode, 7 Bit Controls
User Defined Keys Unlocked User Defined Keys Shifted
User Features Unlocked Multinational
Numeric Keypad Normal Cursor Keys No New Line
Replace Mode Printer: None
```

SN-0014-87

Figure 4-5 General Set-Up

Table 4-5 General Set-Up Screen

Field	Function
To Next Set-Up Action field Value: To Next Set-up	Replaces the General Set-up screen with the Communications Set-up screen.
To Directory Action field Value: To Directory	Replaces the General Set-up screen with the Set-up Directory screen.

Table 4-5 General Set-Up Screen (Cont)

Field	Function
<p>Mode _____ Parameter field</p>	<p>Selects the basic text operating mode.</p>
<p>Values:</p>	
<p><input type="checkbox"/> VT200 Mode,7-Bit Controls(default)</p>	<p>VT200 Mode 7 Bit Controls sets the terminal to operate with a full range of capabilities using 8-bit graphic characters and 7-bit controls. This is the recommended mode for most applications.</p>
<p><input type="checkbox"/> VT200 Mode,8-Bit Controls</p>	<p>VT200 Mode 8 Bit Controls sets the terminal to operate with a full range of capabilities in an 8-bit environment with 8-bit controls. Many applications designed for the VT100 will run in this mode.</p>
<p><input type="checkbox"/> VT52 Mode</p>	<p>VT52 Mode sets the terminal for use with application programmes designed for a VT52 terminal.</p>
<p><input type="checkbox"/> VT100 Mode</p>	<p>VT100 Mode sets the terminal for use with application programmes designed for a VT100 terminal requiring strict VT100 compatibility. In general, VT200 Mode, 7 Bit Controls is the preferred mode to use.</p>
<p>VT100 _____ Parameter field</p>	<p>Selects the device attributes sent to the host computer.</p>
<p>Values:</p>	
<p><input type="checkbox"/> VT220 ID (default)</p>	<p>Causes the terminal to send the device attributes of a VT220 terminal to the host computer.</p>
<p><input type="checkbox"/> VT100 ID</p>	<p>Causes the terminal to send the device attributes of a VT100 terminal to the host computer.</p>

Table 4-5 General Set-Up Screen (Cont)

Field	Function
<input type="checkbox"/> VT101 ID	Causes the terminal to send the device attributes of a VT101 terminal to the host computer.
<input type="checkbox"/> VT102 ID	Causes the terminal to send the device attributes of a VT102 terminal to the host computer.
User Defined Keys _____ Parameter field	Selects whether or not the host can alter User Defined Key definitions.
Values:	
<input type="checkbox"/> User Defined Keys Locked	User defined keys locked prevents UDKs from being loaded.
<input type="checkbox"/> User Defined Keys Unlocked (default)	User defined keys unlocked allows UDKs to be loaded.
User Defined Keys _____ Parameter field	Selects if the UDK are Shift F6 through Shift F20 or F6 through F20.
Values:	
<input type="checkbox"/> Users Defined Keys Shifted (Default)	
<input type="checkbox"/> Users Defined Keys Unshifted	
User Features _____ Parameter field	Selects whether or not the host can change user-preference features you have set.
Values:	
<input type="checkbox"/> User Features Unlocked (default)	The following user preference features are affected by this feature:
<input type="checkbox"/> User Features Locked	<ul style="list-style-type: none"> - Auto Repeat - Smooth/Jump Scroll - Light/Dark Screen - Tab Stops - Keyboard Lock

Table 4-5 General Set-Up Screen (Cont)

Field	Function
	NOTE: Some software applications expect to control these user features. If this applies to your particular software, the value of the field should be set to "User Features Unlocked" to ensure predictable behaviour.
Character Set Mode	Selects either the national or multinational character set mode.
Parameter field	NOTE: If the North American keyboard has been selected, only multinational mode is available for use. National mode is disabled.
Values:	
<input type="checkbox"/> Multinational (default)	Enables the terminal to generate 8-bit multinational characters, including 7-bit ASCII characters.
<input type="checkbox"/> National	Causes the terminal to use one of eleven 7-bit national replacement character sets. The NRC set depends on the keyboard field selected in the Set-Up Directory screen.
____ Keypad	Selects whether the keypad transmits ASCII character codes or escape sequences.
Parameter field	
Values:	
<input type="checkbox"/> Numeric Keypad (default)	Numeric keypad causes the auxiliary keypad to transmit ASCII character codes corresponding to the numeric characters on the keys.
<input type="checkbox"/> Application Keypad	Application keypad causes the auxiliary keypad to transmit escape sequences used by an application programme.
____ Cursor Keys	Selects whether the cursor keys transmit ANSI cursor control sequences or application control functions.
Parameter field	

Table 4-5 General Set-Up Screen (Cont)

Field	Function
Values:	
<input type="checkbox"/> Normal Cursor Keys (default)	Normal Cursor Keys transmit ANSI cursor control sequences (up, down, left and right).
<input type="checkbox"/> Application Cursor Keys	Application cursor keys transmit application programme control functions.
<u> </u> New Line Parameter field	Selects whether the keyboard Return key generates a carriage return only or a carriage return and a line feed.
Values:	
<input type="checkbox"/> No New Line (default)	No new line causes the Return key to generate a carriage return only.
<input type="checkbox"/> New Line	New line causes the Return key to generate a carriage return and a line feed.
	NOTE: When the terminal is in Numeric Keypad mode, this feature affects the Enter key in the same way it does the Return key.

COMMUNICATIONS SET-UP SCREEN

The Communications Set-Up screen (Figure 4-6) lets you define the terminal-host communication environment.

All fields on this screen are described in Table 4-6.

```
Communications Set-Up                               VT225-V1.0
To Next Set-Up  To Directory  Transmit=4800  Receive=Transmit
XOFF at 64     8 Bits, No Parity          1 Stop Bit  No Local Echo
RS232 Port, Data Leads Only  Disconnect, 2 s Delay  Limited Transmit
Replace Mode  Printer: None
```

SN-0015-87

Figure 4-6 Communications Set-Up

Table 4-6 Communications Set-Up Screen

Field	Function
To Next Set-Up Action field Value: To Next Set-up	Replaces the Communications Set-up screen with the Printer Set-up screen.
To Directory Action field Value: To Directory	Replaces the Communications Set-up screen with the Set-Up Directory screen.

Table 4-6 Communications Set-Up Screen (Cont)

Field	Function
Transmit= _____ Parameter field Values: <input type="checkbox"/> Transmit= 75 <input type="checkbox"/> Transmit= 110 <input type="checkbox"/> Transmit= 150 <input type="checkbox"/> Transmit= 300 <input type="checkbox"/> Transmit= 600 <input type="checkbox"/> Transmit= 1200 <input type="checkbox"/> Transmit= 2400 <input type="checkbox"/> Transmit= 4800 (default) <input type="checkbox"/> Transmit= 9600 <input type="checkbox"/> Transmit=19200	Selects the rate at which the terminal sends data to the host computer. The terminal transmit speed must be set to match the computer receive speed. The terminal however, can transmit at one speed and receive at another. NOTE: This feature does not set the format for the printer port.
Receive= _____ Parameter field Values: <input type="checkbox"/> Receive= 75 <input type="checkbox"/> Receive= 110 <input type="checkbox"/> Receive= 150 <input type="checkbox"/> Receive= 300 <input type="checkbox"/> Receive= 600 <input type="checkbox"/> Receive= 1200 <input type="checkbox"/> Receive= 2400 <input type="checkbox"/> Receive= 4800 <input type="checkbox"/> Receive= 9600 <input type="checkbox"/> Receive= 19200 <input type="checkbox"/> Receive=Transmit	Selects the rate at which the terminal receives data from the host computer. The terminal receive speed must be set to match the computer transmit speed. The terminal however, can receive at one speed and transmit at another. The default for this feature is "Receive=Transmit".
_____XOFF_____ Parameter field Values: <input type="checkbox"/> XOFF at 64 (default) <input type="checkbox"/> XOFF at 128 <input type="checkbox"/> No XOFF	Selects the XOFF point or disables the automatic XON/XOFF flow control (see Chapter 5, Data Flow Control). For most applications you should set XOFF at 64 or 128.

Table 4-6 Communications Set-Up Screen (Cont)

Field	Function
<p><u> </u> Bits, <u> </u> Parity <u> </u></p> <p>Parameter field</p> <p>Values:</p> <ul style="list-style-type: none"> <input type="checkbox"/> 8 Bits, No Parity (default) <input type="checkbox"/> 8 Bits, Even Parity <input type="checkbox"/> 8 Bits, Odd Parity <input type="checkbox"/> 7 Bits, No Parity <input type="checkbox"/> 7 Bits, Even Parity <input type="checkbox"/> 7 Bits, Odd Parity <input type="checkbox"/> 7 Bits, Mark Parity <input type="checkbox"/> 7 Bits, Space Parity <input type="checkbox"/> 7 Bits, Even Parity No Check <input type="checkbox"/> 7 Bits, Odd Parity, No Check <input type="checkbox"/> 8 Bits, Even Parity No Check <input type="checkbox"/> 8 Bits, Odd Parity No Check 	<p>Selects the character format used for communication with the host computer (see Chapter 5, Character Format).</p> <p>NOTE: This feature does not set the format for the printer port.</p>
<p><u> </u> Stop Bit <u> </u></p> <p>Parameter field</p> <p>Values:</p> <ul style="list-style-type: none"> <input type="checkbox"/> 1 Stop Bit (default) <input type="checkbox"/> 2 Stop Bits 	<p>Sets the number (1 or 2) of stop bits used by the host port (see Chapter 5, Character Format).</p> <p>NOTE: This feature does not set the format for the printer port.</p>
<p>Local Echo</p> <p>Parameter field</p> <p>Values:</p> <ul style="list-style-type: none"> <input type="checkbox"/> Local Echo <input type="checkbox"/> No Local Echo (default) 	<p>Enables or disables the local echo feature.</p> <p>Local Echo directs data from the keyboard to monitor screen as well as the host computer.</p> <p>No Local Echo directs data from the keyboard to the host computer only; which may or may not send the data back to the terminal screen.</p>

Table 4-6 Communications Set-Up Screen (Cont)

Field	Function
____ Port ____	Selects the type of port used for communication with the host computer (see Chapter 5, Host and Printer Port Interfaces).
Parameter field	
Values:	
[] DEC423 Port Data leads only	Select the DEC423 port if the terminal connects to the host computer via the DEC423 port.
[] DEC423 Port, Modem Control	Select the DEC423 Port, using Modem control.
[] EIA232 Port, Data Leads Only (default)	Select EIA232 Port, Data Leads Only if the terminal connects to the host computer via the COMM port.
[] EIA232 Port, Modem Control	Select EIA232 Port, Modem Control if the terminal connects to the host via the COMM port and an external modem requiring EIA modem control is used.
	<p>Note: The terminal keeps two distinct sets of host parameters, one for the EIA232 port and the other for the DEC423 port.</p>
	<p>These parameters are swapped whenever this field is switched between EIA232 and DEC423.</p>
	<p>Transmit Speed Receive Speed Number of Bits per Character Parity Stop Bits</p>

Table 4-6 Communications Set-Up Screen (Cont)

Field	Function
Disconnect, ___ Delay Parameter field	When modem control is used, the disconnect delay feature determines the time allowed before the terminal disconnects from the communications line when the received line signal detection (RLSD) is lost.
Values: <input type="checkbox"/> Disconnect, 2s Delay (default) <input type="checkbox"/> Disconnect, 60ms Delay	The 60ms delay is provided for use in the United Kingdom. All other countries should use the 2s delay.
_____ Transmit Parameter field	Limited transmit limits the terminal transmit speed to 150-180 characters per second, regardless of the baud rate. This places a minimal interrupt burden on the host operating system.
Values: <input type="checkbox"/> Limited Transmit (default) <input type="checkbox"/> Unlimited Transmit	

PRINTER SET-UP SCREEN

The Printer Set-up screen (Figure 4-7) lets you define printer operation with the VT225.

All fields on this screen are described in Table 4-7.

```
Printer Set-Up VT225-V1.0
To Next Set-Up To Directory Speed=4800 Printer Port
Normal Print Mode 8 Bits, No Parity 1 Stop Bit
Print Full Page Print National Only No Terminator

-----
Replace Mode Printer: Ready
```

SN-0016-87

Figure 4-7 Printer Set-Up

Table 4-7 Printer Set-Up Screen

Field	Function
To Next Set-Up Action field Value: To Next Set-up	Replaces the Printer Set-up screen with the Keyboard Set-up screen.
To Directory Action field Value: To Directory	Replaces the Printer Set-up screen with the Set-up Directory screen.

Table 4-7 Printer Set-Up Screen (Cont)

Field	Function
Speed=_____	Selects the rate at which the terminal sends data to a hardcopy printer.
Parameter field	
Values:	
<input type="checkbox"/> Speed= 75	
<input type="checkbox"/> Speed= 110	
<input type="checkbox"/> Speed= 150	
<input type="checkbox"/> Speed= 300	
<input type="checkbox"/> Speed= 600	
<input type="checkbox"/> Speed= 1200	
<input type="checkbox"/> Speed= 2400	
<input type="checkbox"/> Speed= 4800 (default)	
<input type="checkbox"/> Speed= 9600	
<input type="checkbox"/> Speed=19200	
_____Port	Selects the usage of the Printer Port.
Parameter field	
Values:	
<input type="checkbox"/> Printer Port	Port only allows output, all input except for XON and XOFF is discarded.
<input type="checkbox"/> Auxiliary Port	Port allows full two way communications, with the host.
_____Mode	Selects the operating mode for the printer.
Parameter field	
Values:	
<input type="checkbox"/> Normal Print Mode (default)	Normal Print Mode enables print functions to be invoked from the keyboard.
<input type="checkbox"/> Auto Print Mode	Auto Print Mode causes the current line of text to be printed on receipt of linefeed, form feed, or vertical tab codes from the host.

Table 4-7 Printer Set-Up Screen (Cont)

Field	Function
<input type="checkbox"/> Controller Mode	Controller Mode causes the printer port to treat the printer as a terminal while the VT225 monitors traffic. The host computer transfers data to the printer without the data being displayed on the terminal screen.
____ Bits, ____ Parity Parameter field	Selects the character format used by the printer port (see Chapter 5, Character Format).
Values:	
<input type="checkbox"/> 7 Bits, No Parity	
<input type="checkbox"/> 7 Bits, Mark Parity	
<input type="checkbox"/> 7 Bits, Space Parity	
<input type="checkbox"/> 7 Bits, Even Parity	
<input type="checkbox"/> 7 Bits, Odd Parity	
<input type="checkbox"/> 8 Bits, No Parity (default)	
<input type="checkbox"/> 8 Bits, Even Parity	
<input type="checkbox"/> 8 Bits, Odd Parity	
____ Stop Bit ____	Sets the number of stop bits (1 or 2) to match those used by the printer.
Values:	
1 Stop Bit (default)	
2 Stop Bits	
Print ____ Parameter field	Selects how much of the screen (the full screen or just the scrolling region) is to be printed during a print page operation.
Values:	
<input type="checkbox"/> Print Full Page (default)	
<input type="checkbox"/> Print Scroll Region	

Table 4-7 Printer Set-Up Screen (Cont)

Field	Function
Printed Data Type Parameter	Selects the type of characters (from the terminal's character sets) to be sent to the printer.
Values:	
<input type="checkbox"/> Print National Only (default)	Use with a printer that supports ASCII (multinational mode) or the current national set (national mode). (Examples: LA34, LA36, LA120, non-Digital printers).
<input type="checkbox"/> Print National and Line Drawing	Use with a printer that supports ASCII and the line drawing sets (multinational mode), or the current national set and the line drawing set (national mode). (Example: LA100).
<input type="checkbox"/> Print Multi-national	Use with a printer that supports the multinational and line drawing sets. (Example: LA50).
Print Terminator Parameter field	Selects whether or not a terminator (form feed) is sent at the end of a print page operation.
Values:	
<input type="checkbox"/> Terminator = FF	
<input type="checkbox"/> No Terminator (default)	

KEYBOARD SET-UP SCREEN

The Keyboard Set-up screen (Figure 4-8) lets you define operating features associated with the keyboard.

All fields on this screen are described in Table 4-8.

```
Keyboard Set-Up                               VT225-V1.0
To Next Set-Up  To Directory  Typewriter Keys  Caps Lock
Auto Repeat    Keyclick     Margin Bell  Warning Bell  Break
Auto Answerback  Answerback=  Not Concealed
Replace Mode    Printer: None
```

SN-0017-87

Figure 4-8 Keyboard Set-Up

Table 4-8 Keyboard Set-Up Screen

Field	Function
To Next Set-Up Action field Value: To Next Set-Up	Replaces the Keyboard Set-Up screen with the Tab Set-up screen.
To Directory Action field Value: To Directory	Replaces the Keyboard Set-Up screen with the Set-Up Directory screen.

Table 4-8 Keyboard Set-Up Screen (Cont)

Field	Function
_____ Keys Parameter field	Sets the terminal keyboard map for the type of keyboard you are using.
Values:	
[] Typewriter Keys (default)	If your keyboard is North American, select Typewriter Keys. For all other keyboards, select either Typewriter or Data Processing Keys. Selecting Typewriter keys causes the terminal to generate the characters shown on the left half of the keycaps; selecting Data Processing Keys generates the characters shown on the right half of the keycaps. For example: The French Canadian keyboard uses a key that has a C cedilla (on the left side), and a "[]" (on the right side). Selecting Typewriter Keys makes the key respond as upper and lower case C cedilla.
[] Data Processing Keys	Selecting Data Processing Keys make the key respond as "[]".
_____ Lock Parameter field	Selects the function of the keyboard Lock key. Pressing the Lock key lights the Lock indicator on the keyboard. To clear the Lock function simply press the Lock key again (the Lock indicator turns off).
Values:	
[] Caps Lock (default)	When Caps Lock is selected the alphabetic keys generate uppercase characters only.
[] Shift Lock	When Shift Lock is selected, the alphabetic keys generate uppercase characters and the numeric/symbol keys generate the top characters only. Shift Lock can also be cleared by pressing the Shift key.

Table 4-8 Keyboard Set-Up Screen (Cont)

Field	Function
Auto Repeat	Selects whether or not keystrokes are automatically repeated when you hold down a key.
Parameter field	
Values:	
<input type="checkbox"/> Auto Repeat (default)	Auto Repeat continues to generate the character until the key is released.
<input type="checkbox"/> No Auto Repeat	No Auto Repeat requires a separate keystroke for each character generated.
Keyclick	Selects whether or not the keyboard generates a "click" sound each time a key is pressed.
Parameter field	
Values:	
<input type="checkbox"/> Keyclick (default)	
<input type="checkbox"/> No Keyclick	
Margin Bell	Selects whether or not the terminal generates a bell tone when the text cursor approaches the right margin.
Parameter field	
Values:	
<input type="checkbox"/> Margin Bell (default)	
<input type="checkbox"/> No Margin Bell	
Warning Bell	Selects whether or not the terminal generates a bell tone for operating errors, and receipt of Ctrl-G.
Parameter field	
Values:	
<input type="checkbox"/> Warning Bell (default)	
<input type="checkbox"/> No Warning Bell	

Table 4-8 Keyboard Set-Up Screen (Cont)

Field	Function
Break Parameter field	Enables or disables the Break key function (see Chapter 3, Break).
Values: <input type="checkbox"/> Break (default)	Terminal disconnect (Shift-Break) is not affected by this feature (see Chapter 5, Connect/Disconnect).
<input type="checkbox"/> No Break	
Auto Answerback Parameter field	Selects whether or not the answerback message is automatically sent to the host computer after a communication line connection.
Values: <input type="checkbox"/> Auto Answerback (default)	
<input type="checkbox"/> No Auto Answerback	
Answerback= Text Parameter field	Allows an answerback message entry.
Value: Text Entry	The answerback message is a message which is sent on receipt of ENQ or by typing Ctrl-Break. In the case of ENQ, the message you enter is sent to the host without affecting screen data or requiring further operator action.
	When selected, the Set-Up status line displays the prompt "Enter Answerback = " (temporarily overwriting the status line). You can enter any character that the keyboard generates up to a 30 character limit.
	Your message can be "concealed" using the Concealed feature in this Set-up Screen.

Table 4-8 Keyboard Set-Up Screen (Cont)

Field	Function
Concealed	Selects whether or not your answerback message entry is displayed on the screen.
Parameter field	
Value:	
<input type="checkbox"/> Concealed	When Concealed is selected, your answerback message is not displayed on the screen so it will not be revealed. This feature cannot be reset to Not Concealed except by entering a new answerback message.
<input type="checkbox"/> Not Concealed (default)	Not Concealed allows the terminal to display the answerback message as entered.

TAB SET-UP SCREEN

The Tab Set-Up Screen (Figure 4-9) lets you set the terminal tab stop settings.

All fields on this screen are described in Table 4-9.

The tab stop fields are single-character width fields strung together. Beneath the tab stop fields the screen displays a ruler to reference when setting tabs.

The tab fields and ruler can be either 80 or 132 columns wide depending on the number of columns set (see Columns, in the Display Set-Up screen).

Each tab stop field can show a "T" (tab stop setting) or can be blank (no tab stop setting).

The field cursor is controlled using the arrow keys, or the tab key. Pressing the Enter key after you select a field places a "T" in a blank field or removes an existing "T" from that field.

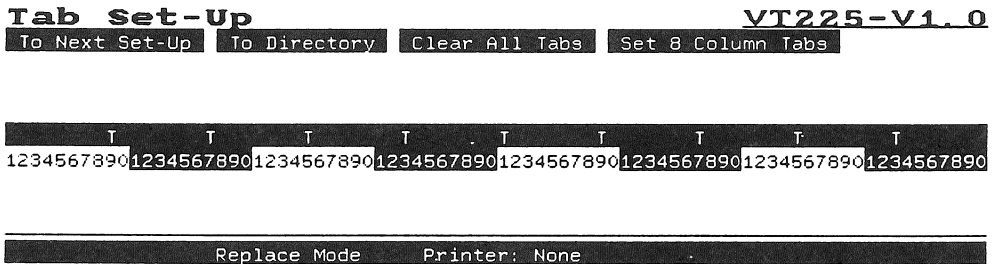

SN-0018-87

Figure 4-9 Tab Set-Up

Table 4-9 Tab Set-Up Screen

Field	Function
To Next Set-Up	Replaces the Tab Set-Up screen with the Edit Set-Up screen.
Action field	
Value: To Next Set-Up	
To Directory	Replaces the Tab Set-Up screen with the Set-Up Directory screen.
Action field	
Value: To Directory	
Clear All Tabs	Clears all tabs previously set.
Action field	
Value: Clear All Tabs	
Set 8 Column Tabs	Automatically sets tabs every 8 columns starting with column 9.
Action field	
Value: Set 8 Column Tabs	

EDIT SET-UP SCREEN

The Edit Set-Up Screen (Figure 4-10) allows the VT225 State to be changed between On-Line-Interactive and On-Line-Edit.

When set to the On-Line-Edit state, this screen allows various Edit state parameters to be modified.

All fields on this screen are described in Table 4-10.

```
Edit Set-Up VT225-V1.0  
To Next Set-Up To Directory Interactive Edit Key=immediate  
Erase All Full Page Transmit Immediate Transmit  
Transmit All No sp compress Eol terminator=CR/CRLF  

---

Replace Mode Printer: None
```

SN-0019-87

Figure 4-10 Edit Set-Up

Table 4-10 Edit Set-Up Screen

Field	Function
To Next Set-Up	Replaces the Edit Set-Up screen with the Colour Set-Up screen.
Action field	
Value: To Next Set-Up	
To Directory	Replaces the Edit Set-Up screen with the Set-Up Directory screen.
Action field	
Value: To Directory	
_____ Mode	Determines if the terminal operates as an editing or interactive terminal.
Values:	
<input type="checkbox"/> Edit Mode	The terminal holds typed characters for local editing. Characters are transmitted to the computer in blocks.
<input type="checkbox"/> Interactive Mode (default)	The terminal transmits typed characters to the computer immediately.
Edit Key=_____	Determines how the EDIT key operates.
Values:	
<input type="checkbox"/> Edit Key = Immediate (default)	SHIFT and EDIT selects either interactive or editing operation immediately.
<input type="checkbox"/> Edit Key = Deferred	SHIFT and EDIT transmits a sequence of characters to the computer. When the computer echoes these characters back to the terminal, the terminal changes between interactive and editing operation.

Table 4-10 Edit Set-Up Screen (Cont)

Field	Function
Erase _____	Determines which characters on the screen the computer can edit.
Values:	
<input type="checkbox"/> Erase All (default)	The computer can edit all characters displayed on the screen.
<input type="checkbox"/> Erase Unprotected	The computer can edit unprotected characters only.
_____ Transmit	Determines the size of the block of characters that the terminal transmits to the computer in edit mode.
Values:	
<input type="checkbox"/> Line Transmit (default)	Causes one line of characters to be transmitted each time RETURN or ENTER is pressed.
<input type="checkbox"/> Partial page Transmit	The characters between a partial page marker and the cursor are transmitted. If a partial page marker is not present, the top margin is used. The marker (which is not displayed) is automatically positioned at the last character transmitted. Characters transmission is started by pressing ENTER.
<input type="checkbox"/> Full page Transmit	All the characters within the margins are transmitted.
_____ Transmit	Determines how the ENTER key operates.
Values:	
<input type="checkbox"/> Immediate Transmit (default)	The terminal transmits characters when the ENTER key is pressed.
<input type="checkbox"/> Deferred Transmit	The terminal transmits a character sequence to request a block character transmission. When the computer is ready to receive the characters, it transmits a sequence of characters to begin transmission.

Table 4-10 Edit Set-Up Screen (Cont)

Field	Function
Transmit _____	This feature determines what characters (protected, unprotected, modified) are transmitted to the computer. When the terminal is operating as an editing terminal, characters on the screen are either protected or unprotected. Only unprotected characters may be edited (modified) from the keyboard.
Values:	
<input type="checkbox"/> Transmit All (default)	All characters on the screen are transmitted.
<input type="checkbox"/> Transmit Modified	Only (unprotected) characters that have been modified since the last transmit are transmitted.
<input type="checkbox"/> Transmit Unprotected	Only unprotected characters are transmitted.
_____ Compress	Determines if unused character positions on the screen are transmitted as space characters or as a single control character that represents the remaining spaces of a field.
Values:	
<input type="checkbox"/> Space Compress	The remaining spaces of a field are not transmitted. A field, when transmitted, ends with the RS (record separator) control character.
<input type="checkbox"/> No Space Compress (default)	Unused character positions on the screen are transmitted as space characters.

Table 4-10 Edit Set-Up Screen (Cont)

Field	Function
<u> EOL Terminator </u>	Determines whether or not the terminal transmits an end of line character during a block transmission. Also determines the end of line character to be used.
Values:	
<input type="checkbox"/> EOL Terminator = CR/LF (default)	The character(s) transmitted by RETURN (as determined by the linefeed/new line feature) indicates the end of a line during block transmission.
<input type="checkbox"/> EOL Terminator = RS	The RS (record separator) is the end of line character.
<input type="checkbox"/> No EOL Terminator	No end of line character is transmitted.

COLOUR SET-UP SCREEN

The Colour Set-Up Screen (Figure 4-11) allows the VT225 User Defined Palette to be displayed and altered.

The Change Colour field shows which colour is selected for making changes. Colours are changed by using the arrow keys to move the red highlighted [] marker to a different position. The left and right arrow keys change the colour intensity, and the up and down arrow keys control the colour selected. All fields are described in Table 4-11.

Colour Set-Up

VT225-V1.0

To change a colour, position cursor on the Change Colour field, select the colour number using Enter, then Down Arrow, adjust the mix of Red, Green, and Blue using the arrow keys.

<-----Foreground-----> <-----Background----->
0 1 2 3 4 5 6 7 0 1 2 3 4 5 6 7



To Next Set-Up To Directory Default Colours Change Colour F1

	0	1	2	3
Red				[]
Green			[]	
Blue			[]	

Replace Mode Printer: None

SN-0020-87

Figure 4.11 Colour Set-Up Screen

Care should be taken to make sure that Foreground/Background combinations are sufficiently different for the characters to be readable.

In the default settings of the User Defined Palette Colour 0 is black on black (invisible).

Table 4.11 Colour Set-Up Screen

Field	Function
To Next Set-Up	Replaces the Colour Set-Up Screen with the Display Set-Up Screen.
Action Field Value: To Next Set-Up	
To Directory	Replaces the Colour Set-Up Screen with the Set-Up Directory screen.
Action Field Value: To Directory	
Default Colours	Sets all colours in the User defined palette to their default colours
Action Field Value: Default Colours	
Change Colour	Selects the colour to be changed by the user.
Parameter Field Value: F0 to F7 and B0 to B7	F0 to F7 are the eight foreground colours and B0 to B7 are the background colours.

CREATING A PERSONAL COLOUR PALETTE

Users can change the colours using the Set-up Colour menu.

Try the following:

Press the Set-Up key, and select the Display screen. Move to the Select Colour Palette field and select User Definable Palette.

Return to the Set-up Directory screen using the To Directory field, and select the Colour Display.

Select the colours as follows using the Change Colour field and Red[] Green[] Blue[] fields:

Field	Colour Values	Colour
F2	Red[3] green[3] blue[3]	White Default Foreground
B2	Red[0] green[0] blue[1]	Dark Blue Default Background
F3	Red[3] green[0] blue[0]	Red Bold Foreground
B3	Red[3] green[3] blue[3]	White Bold Background

Press Set-Up to exit to normal operation.

Your colour setup may be saved in non-volatile memory from the Set-Up Directory menu.

GENERAL

This chapter describes the VT225 communications environment with a host computer and a hard-copy printer.

The terminal operates on full-duplex asynchronous lines only, and has ten possible transmit/receive speeds. The transmit/receive speeds are selected in Set-Up for both the terminal (Communications Set-Up Screen) and the printer (Printer Set-Up Screen).

The VT225 is compatible with the following national and international communications standards:

- o EIA Standard EIA-232-D/RS423-A
- o CCITT V.24
- o CCITT V.26 (V.10)
- o CCITT X.20 (V.21)

The terminal can be connected directly to a local host computer via cable. The terminal can also be connected indirectly to a remote host computer through public-switched or dedicated telephone lines using a modem or acoustic coupler.

HOST AND PRINTER PORT INTERFACES

The VT225 has three asynchronous serial ports; two for communication with a host computer, and another for communication with a hard-copy printer.

There are two physical host port connectors:

- o A 25-pin Subminiature D Type (EIA-232-D/RS423-A compatible) connector used to connect the terminal to a local or remote host computer.
- o A 6-pin Digital Equipment Corporate Modified Modular Jack (DEC423 local direct connect).

The printer port has one connector:

- o A 9-pin Subminiature D Type (EIA-232-D/RS423-A Compatible) connector used to connect the terminal to a local hard-copy printer.

The interface signals for the three connectors are listed and described in Tables 5-1 through 5-3.

NOTE: Connector pins not listed in Tables 5-1 and 5-2 are not connected.

Table 5-1 Comm Port EIA-232-D Interface Signals

Pin	Signal	Mnemonic	EIA/CCITT/DIN	Description
2	Transmit Data	TXD	BA/103/D1	From VT225: Transmits serial characters. Held in mark state when no characters are transmitted. In modem control modes, transmits data only when RTS,CTS,DSR, and DTR are on.
3	Received Data	RXD	BB/104/D2	To VT225: Receives serial characters. In modem control modes, ignores characters if RLSD is off.
4	Request to Send	RTS	CA/105/S2	From VT225: When on, places the modem in transmit mode.
5	Clear to Send	CTS	CB/106/M2	To VT225: When on, tells the terminal that the modem is ready to transmit.

Table 5-1 (Cont.) Comm Port EIA Interface Signals

Pin	Signal	Mnemonic	EIA/CCITT/DIN	Description
6	Data Set Ready	DSR	CC/107/M1	To VT225: When on, tells the terminal that the modem is in the data mode and is ready to exchange RTS,CTS, and RLSD.
7	Signal Ground	SGND	AB/102/E2	Common ground reference potential for all connector signals except protective ground.
8	Receive Line Signal Detect (carrier detect)	RLSD	CF/109/M5	To VT225: When on, tells the terminal that the signal received on the communication line is of sufficient quality to insure proper demodulation of received data. When off, indicates no signal received or signal unsuitable for demodulation.
12	Speed Indicator	SPDI	CI/112/M4	To VT225: When on, enables modem to control terminal transmit and receive speeds. Causes terminal transmit and receive speeds to be 1200 bits per second regardless of Set-Up selection.

Table 5-1 Comm Port EIA Interface Signals (Cont)

Pin	Signal	Mnemonic	EIA/CCITT/DIN	Description
20	Data Terminal Ready	DTR	CD/108.2/S1.2	From VT225: When on, tells the modem that the terminal is ready to transmit or receive.
23	Speed Select	SPDS	CH/111/S4	From VT225: When on, tells the modem that receive speed selection in Set-Up is greater than 600 bits per second.

Table 5-2 Printer Port EIA Interface Signals

Pin	Signal	Mnemonic	EIA/CCITT/DIN	Description
2	Transmitted Data	TXD	BA/103/D1	From VT225: Transmits serial characters. Held in mark state when no characters are transmitted.
3	Receive Data	RXD	BB/104/D2	To VT225: Receives serial characters.
4	Request to Send	RTS	CA/105/S2	From VT225: On when the terminal is on.
5	Data Terminal Ready	DTR	CD/108.2/S1.2	From VT225: On when the terminal is on.
6	Data Set Ready	DSR	CC/107/M1	To VT225: Receives DTR on this line. If DSR is present at power-up, the printer controls print operations. If DSR is not present at power-up, the terminal checks for DSR before each character print operation.
7	Signal Ground	SGND	AB/102/E2	Common ground reference for all voltages on interface.

MODEMS

The VT225 can operate with all modems conforming to the national and international standards and recommendations listed at the beginning of this chapter. The modem at the terminal end must, however, be compatible with the modem at the host computer end.

CABLES

The EIA-232-D and DEC423 cables that can be used to connect the terminal to a host computer and hard-copy printer are identified in Figure 5-1.

PRINTERS

The terminal can be connected to a local asynchronous serial printer using a null-modem cable. See PRINTING in chapter 3.

CHARACTER FORMAT

The terminal transmits and receives characters serially formatted. The character format, selectable in Set-Up, is shown in Figure 5-2.

NOTE: Detailed information on character format is available in ANSI Standard X3.15.

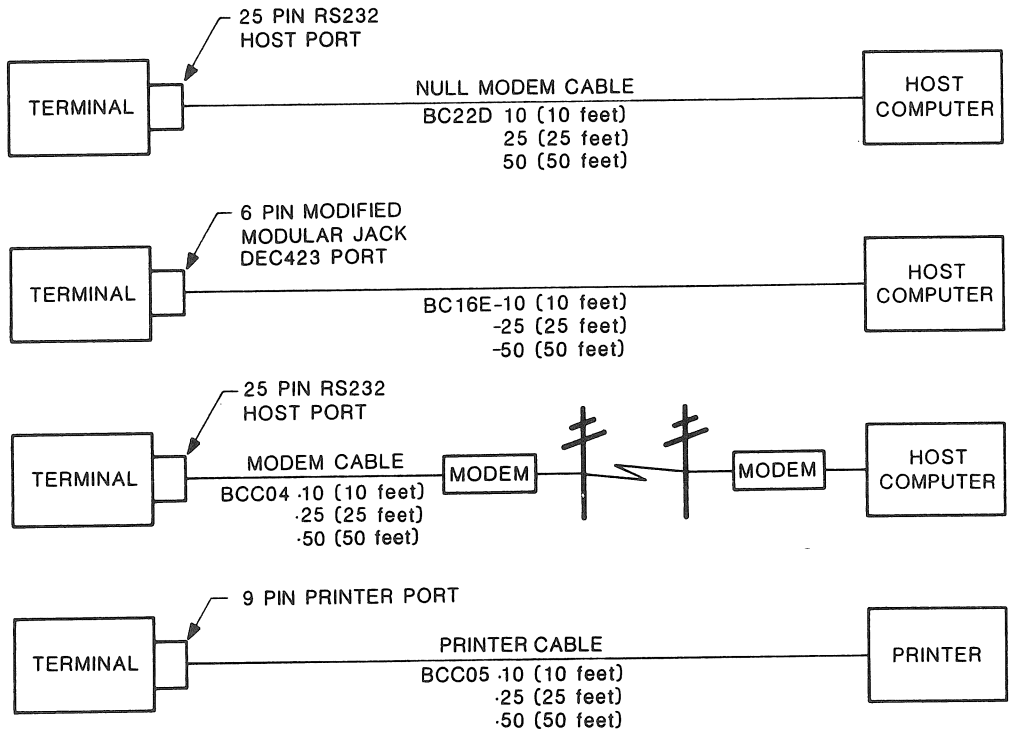

SN-0007-87

Figure 5-1 Cables

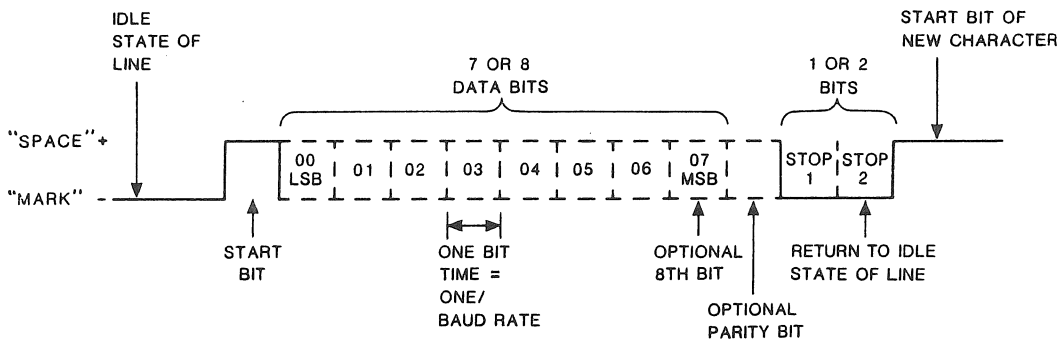

SN-0089-87

Figure 5-2 Character Format

TERMINAL/HOST DATA FLOW CONTROL

The terminal stores incoming characters in a character input buffer and processes the characters on a first-in/first-out basis. The size of the input buffer is 254 characters. When the input buffer fills to 64 or 128 characters (selected in Set-Up), the terminal transmits an XOFF character (if XOFF is enabled in Set-Up) to stop the host computer from sending more characters.

If the computer fails to respond to the XOFF character, the terminal sends a second XOFF character when the input buffer fills to 220 characters. The terminal sends a third XOFF character when the buffer is full.

When the input buffer contents falls below 32 characters, the terminal transmits an XON character to signal the host computer to start sending characters again.

NOTE: If XOFF is disabled in Set-Up, the input buffer filling condition does not send XOFF to the host computer and the keyboard Hold Screen key is disabled. With XOFF disabled, there is no way to ensure that data will not be lost.

If XON/XOFF is enabled, the terminal recognizes received XON and XOFF. Receipt of XOFF stops the terminal from transmitting (except XON/XOFF characters). If the keyboard data buffer overflows, the keyboard "locks" and the Wait indicator lights. Transmission resumes upon receipt of XON.

Conditions That Transmit XON

When the XOFF/XON feature is enabled in Set-Up, the following conditions transmit XON.

- o The number of characters in the input buffer reaches the XON point (32 characters) and the last flow control character sent was XOFF.
- o The Clear Comm function is performed.
- o The Recall function is performed.
- o The self-test is completed.
- o The Hold Screen key is pressed to "release" the screen when the input buffer is at or below the XON point.

Conditions That Transmit XOFF

When the XOFF/XON feature is enabled in Set-Up, the following conditions transmit XOFF.

- o The number of characters in the input buffer reaches the first XOFF point (64 or 128 characters, selected in Set-Up) for the first time since the last XON was sent.
- o The number of characters in the input buffer reaches the second XOFF point (220 characters) for the first time since the last XON was sent.
- o A character is received when the input buffer is full (254 characters).

Buffer Overflow Prevention

If the host computer does not respond to the XOFF from the terminal, the input buffer continues to fill with characters. If the buffer is filled and characters are still coming, the buffer "overflows" and characters are lost. In place of lost characters, the terminal displays reverse question mark characters (¿).

The following formulas can be used to determine how fast the host computer must respond to the first XOFF character to prevent loss of characters due to buffer overflow. Overflow is calculated first, then host response time.

NOTE: These formulas assume that the transmit rate limit feature in Set-Up is set to Unlimited.

1. Overflow

$$OVFL = (MXBF - XOFF) - [3 \times (RCDR/XMDR)] - (RCDR/600)$$

Where:

OVFL = the number of characters to overflow

MXBF = the receive buffer size (254 characters)

XOFF = the first XOFF point (64 or 128)

RCDR = the received data rate (receive speed)

XMDR = the transmitted data rate (transmit speed)

2. Host Response Time

$$HRST = OVFL \times [(DATA + STOP + PRTY + 1)/RCDR]$$

Where:

HRST = the host computer response time (in seconds)

OVFL = the number of characters to overflow

DATA = the number of data bits per character

STOP = the number of stop bits per character

PRTY = the number of parity bits per character

Example - The VT225 transmits and receives 8-bit characters with no parity at 4800 bps. There is 1 stop bit. XOFF is sent when the buffer has 64 characters in it.

$$\begin{aligned}\text{OVFL} &= (254 - 64) - [3 \times (4800/4800)] - (4800/600) \\ &= 179 \text{ characters}\end{aligned}$$

$$\begin{aligned}\text{HRST} &= 179 \times [(8 \text{ bits} + 1 \text{ bit} + 0 \text{ bits} + 1)/4800] \\ &= 0.37 \text{ seconds}\end{aligned}$$

Therefore, the host computer must stop transmitting in 0.37 seconds or the terminal input buffer will overflow.

Use of Fill Characters

Software that does not support receipt of XON/XOFF characters from the terminal can use all the terminal features by using fill characters. In some applications, the terminal can be used without XON/XOFF support or the use of fill characters, if the bit rate is limited to 9600 and the software does not send the ESC (escape code), use slow scrolling, split screen, or the printer port.

Connect/Disconnect

When a connection is made to the host computer via a modem, the terminal performs the following operations to ensure it is ready to send and receive.

- o Unlocks the keyboard (if it was locked)
- o Clears any transmit in progress
- o Clears the keyboard buffer and all message buffers
- o Clears the input buffer
- o Clears XOFF sent and XOFF received

A communications line disconnect is caused by the following conditions.

- o Performing a Shift-Break operation
- o Invoking Recall or Default values in Set-Up
- o Loss of DSR
- o Loss of RLSD for user-defined time in Set-Up
- o No RLSD within 30 seconds after DSR
- o Receipt of a self-test command from the host computer
- o Switching from EIA-232-D port to the DEC423 port, or from the DEC423 port to the EIA-232-D port
- o Pressing the Data/Talk key

The usual way to disconnect the terminal from the communications line at the end of communications is to press Shift-Break. The host computer's response to the disconnect signal depends on the computer and the software being used.

TRANSMISSION IN EDIT MODE

In edit mode, all characters you enter from the keyboard are not transmitted to the computer, but are displayed for editing. On request, the characters are then transmitted to the computer as a block of characters. Once you initiate a transmission, the keyboard WAIT indicator turns on and the keyboard locks until transmission is complete.

NOTE: You can clear the keyboard locked condition by invoking "Clear Comm" or "Reset Terminal" using SET-UP. This action also clears transmit requests and aborts any transmissions in progress.

Character block transmission begins when the keyboard or computer requests it. The keyboard requests transmission by using ENTER (or RETURN in line transmit mode DECLTM). Transmit execution mode (DECTEM) selects how characters are transmitted. Transmission may be either immediate or deferred.

When transmit execution mode is set, ENTER causes immediate character transmission. When transmit execution mode is reset, ENTER causes transmission of the set transmit state (STS) sequence (ESC S, 1/11 5/3). This sequence notifies the computer that the terminal is ready to transmit. Transmission is deferred and the terminal does not resume transmission until it receives the transmit (DECXMIT) sequence from the computer. The computer can request transmission at any time by using the transmit (DECXMIT) sequence.

NOTE: Character block transmission is aborted when any one of the following Set-Up functions is invoked: Clear Comm, Reset Terminal, Recall and Default.

Block Size

A transmitted character block can be one of three sizes. The block sizes are line, partial page, or full page. Line transmit mode (DECLTM) and transmit termination mode (TTM) determine the character block size.

When line transmit mode (DECLTM) is set, the terminal transmits the line with the cursor. When line transmit mode (DECLTM) is reset, the terminal transmits the full page or partial page as determined by the transfer termination mode (TTM) selection.

When transmit termination mode (TTM) is reset, the terminal transmits the scrolling region from the top of the screen or last partial page marker to the current cursor position (partial page). The partial page marker is an internal page marker which is not displayed. If there is no partial page marker, or the cursor is before the marker, the starting point is the beginning of the scrolling region.

When transmit termination mode (TTM) is set, the terminal transmits the full scrolling region (full page).

Data Compression

Three modes change how many characters of the current display are transmitted. These modes are space compression/field delimiter mode (DECSCFDM), guarded area transmit mode (GATM) and modified area transmit mode (DECMATM).

If guarded area transmit mode is set and space compression/field delimited mode is reset, the terminal transmits all characters in the scrolling region as they are displayed on the screen. The terminal transmits the space character (2/0) if no other character is displayed in a character position.

If space compression/field delimiter mode (DECSCFDM) is set, the terminal does not transmit any trailing spaces in a field. All transmitted fields are ended by a single record separator character (RS, 1/14) except the last field on a line. This last field is ended by a carriage return (CR, 0/13), carriage return and linefeed (CR LF, 0/13 1/10), or record separator (RS, octal 036), depending on the settings of end-of-line character and line feed/new line modes.

If guarded area transmit mode (GATM) is set to all, the terminal transmits protected fields in full. If this mode is reset, a single record separator character (RS, 1/14) is transmitted in place of each protected field.

If modified area transmit mode (DECMATM) is set, then only those fields that have been modified by the operator are sent in full. The fields that have not been changed are replaced by single record separator character (RS, 1/14).

You can use an end of block character (transmit termination character, DECTTC) to indicate the end of a transmitted block. The choices are no character (function disabled), form feed (FF, 0/12), end of text (ETX, 0/3), end of transmission (EOT, 0/4), carriage return (CR, 0/13), or device code 3 (DC3, 1/3).

Transmission Example

Assume the screen line consists of:

"Part No:132576 Description:Video Module"

Assuming that the end-of-block character is set to none and line transmit mode is set and that the end-of-line character is set to record separator, the terminal will transmit the following sequences with different mode settings.

(Note: In 3279 base colour mode palettes protected characters are displayed in different colours from normal characters)

- o Guarded area transmit = all, space compression/field de-limiting = off

Transmit string is

"Part No:132576 Description:Video Module <RS>"

- o Guarded area transmit = unprotected, space compression/field de-limiting = off

Transmit string is

"<RS>132576 <RS>Video Module <RS>"

- o Guarded area transmit = all, space compression/field de-limiting = on

Transmit string is

"Part No:<RS>132576<RS>Description:<RS>Video Module<RS>"

- o Guarded area transmit = unprotected, space compression/field de-limiting = on

Transmit string is

"<RS>132576<RS><RS>Video Module<RS>"

Note: <RS> = denotes a single RS (1/14) character.

Transmission in Edit Mode

When in edit mode with non-immediate shift-edit key selected, pressing the keys:-

PF1, PF2, PF3, PF4, HELP, DO, Shift/HELP, Shift/DO

will send the associated sequences through to the host. This provides a total of eight break through keys, giving six pre-defined sequences and two user definable sequences, for immediate communication with the host.

With immediate shift-edit key selected, pressing any of the above keys will not cause the associated sequence to be send to the host (break through feature disabled).

TERMINAL/PRINTER DATA FLOW CONTROL

The VT225 recognizes XON and XOFF from the printer port for flow control. Upon receipt of XOFF from the printer, the terminal stops sending data until it receives an XON or a Clear Comm Set-up Operation is performed.

Note On Printer Installation

Use of an 8-bit setting for the printer port line implies the use of 8-bit C1 control characters. Use of a 7-bit setting implies the use of the 7-bit ESC [form of C1 control characters.

NOTE: Older printers may not recognize the 8-bit form of C1 control characters. With these printers, the printer line must be set to 7-bits for correct operation.

GENERAL

This chapter describes what to do if there is a problem with the VT225. It provides a problem check list, and describes the Power-Up Self Test.

COMMON OPERATING PROBLEMS

Table 6-1 is a list of common operating problems and their possible solutions. Check this list before calling for service.

Table 6-1 Common Operating Problems

Problem	Possible Solution
The terminal does not power up when the power switch is set to 1 (ON).	Make sure the terminal power cord is plugged into the wall outlet. Check that there is power at the wall outlet by plugging in a lamp to see if it lights.
The printer does not print.	Make sure the printer is plugged in and its power switch is in the on '1' position. Check for tight cable connection between the printer and terminal. Make sure all communication features such as baud rate, parity etc. match.
The terminal display does not resume scrolling. The Hold Screen indicator is on.	Press the Hold Screen key to resume scrolling.
The terminal seems to be "locked" and does not respond to data sent from the host.	Clear the terminal using the Clear Comm field in the Directory Set-Up screen (Chapter 4).

Table 6-1 Common Operating Problems (Cont)

Problem	Possible Solution
The screen is blank. Power OK indicator is on.	The CRT saver feature may be invoked. Press any key to reactivate screen data. Be sure the brightness and contrast controls are properly adjusted.
No bell tone when the terminal is turned on. Keyboard visual indicators are not on.	Make sure the keyboard is connected to the terminal.

POWER-UP SELF TEST

The Power-Up Self Test is performed automatically each time you power up the terminal. During this test cycle, the power-up self test has full control of the terminal. The terminal cannot respond to commands other than those used for the test itself. When the test cycle ends, control is transferred back to the terminal.

In the self test mode, the monitor screen and the keyboard indicators (Hold Screen, Lock, Compose, and Wait) provide information about the terminal operating status. The monitor screen displays a text message, and the keyboard indicators provide a coded message for service personnel.

PERFORMING THE POWER-UP SELF TEST

Start the power-up self test by pressing the terminal power switch to 1 (ON).

During the self test the following should occur.

- o All keyboard indicators turn on and off.
- o The bell tone sounds.

A successful power-up self test ends with all keyboard indicators off and the screen displaying the message shown in Figure 6-1. The message is removed when a character is received from the host computer, or if you press any key.

Any error found by the test is displayed on the screen (if possible). Refer to Table 6-2 for an interpretation of the error messages displayed on the screen.



VT225 Y0.2 OK

Firmware and Set-Up Screens Copyright © 1983,85,86
Digital Equipment Corporation

SN-0090-87

Figure 6-1 Successful Power-Up Screen Message

Table 6-2 Screen Error Messages

Screen Error Message	Problem
VT225 NVR Error - 1	Terminal controller board. The non volatile memory (Set-Up storage) is not operational.
VT225 EIA Port Data Error - 2	Terminal controller board. The host port is not operational.
VT225 Keyboard Error - 4	Keyboard. Terminal is operational to receive input from the host computer only. Make sure the keyboard is plugged in to the terminal.
VT225 Printer Port Error - 6	Printer Port. Terminal is operational but cannot perform printing functions.

DIGITAL SERVICE

If the self test indicates a problem, call your local DIGITAL Field Service office for assistance. Before calling be sure to note the exact nature of the problem, when it occurred and any error messages or codes indicated.

GENERAL

This appendix lists the specifications of the VT225 terminal.

VT225 SPECIFICATIONS

Physical

Terminal	Height:	343 mm (13.5 in)
	Width:	396 mm (15.6 in)
	Depth:	417 mm (16.4 in)
	Weight:	13.5kg (30 lb)

Keyboard	Height:	5.1 cm (2.0 in)
	Width:	53.3 cm (21.0 in)
	Depth:	17.1 cm (6.75 in)
	Weight:	2.0 Kg (4.5 lbs)

Environmental

Operating	Temperature:	10 to 40 C (50 to 104 F)
	Relative Humidity:	10% to 90%
	Maximum Wet Bulb:	28 C (82 F)
	Minimum Dew Point:	2 C (36 F)
	Maximum Altitude:	2.4Km (8000 ft)

Storage	Temperature:	-40 to 66 C (-40 to 151 F)
	Relative Humidity:	0% to 95%
	Maximum Altitude:	9.1Km (30000 ft)

Electrical

Line Voltage (Version Dependant)	90-128 VAC (100-120 VAC RMS nominal) single phase, 3 wire
	190-256 VAC (220-240 VAC RMS nominal) single phase, 3 wire
Line Frequency	47-63 Hz
Line Current	2.2 amps RMS @ 120 VAC RMS 1.2 amps RMS @ 240 VAC RMS
Input Power	125 watts maximum
Power Cord	Detachable, 3 conductor, grounded
Power Cord Receptacle	EIA specified CEE22-6A

Display

CRT	330 mm (13.0 in) diagonal measure
Active Display Size	Horizontal: 242.0 mm (9.5 in) Vertical: 148 mm (5.8 in)
Resolution	80 Column mode: 800 (horizontal) x 350 (vertical) pixels 132 Column mode: 792 (horizontal) x 350 (vertical) pixels
Format	25 lines of 80 or 132 characters
Character	80 column mode: 7 x 9 dot matrix with 3 descenders 132 column mode: 5 x 9 dot matrix with 3 descenders
Character Size	80 column mode: 3.81 x 2.1 mm 132 column mode: 3.81 x 1.5 mm
Character Sets	ASCII, UK National, DEC Special Graphic, and DEC Supplemental Character Sets (each 94 characters)
Video Attributes	Reverse video, underline, bold, and blinking - selectable individually or in any combination

Cursor Type Blinking block character, blinking underline, steady block character, or steady underline.

Keyboard

General 105 key detachable unit with a 1.8 m (6.0 ft) coiled cord with a 4-pin telephone-type modular connector. Word processing and data processing versions available in 15 languages.

Keypad Sculptured key array. Matte texture finish keys. Home row key height 30 mm (1.18 in) above desk top.

Key Size 12.7 mm (0.5 in) square

Key Spacing 19 mm (0.75 in) centre-to-centre (single width keys)

Numeric Keypad 18 keys

Function Keys 36 keys, firmware and software driven.

Visual Indicators 4 LED Indicators: Hold, Lock, Wait and Compose.

Audible Signals

 Keyclick: Audible feedback for each keystroke.

 Bell: Sounds when BEL character received, when 8 characters from right margin and for Compose errors.

 Multiple Bell: Sounds on error in Set-Up Save or Recall operation.

GENERAL

This appendix describes the options, documentation and supplies mentioned in this manual offered by DIGITAL for the VT225. Part numbers and ordering information are included.

Cables

Refer to Chapter 5 for information on available modem and printer cables.

RELATED DOCUMENTATION

In addition to this User's Guide, the VT225 has the following documents that you can order from DIGITAL.

Part Number	Description
EK-VT225-PR	VT225 Programmer's Reference Manual - Describes VT225 character processing, character codes and control sequences needed to generate terminal control programmes.
EK-VT225-IN	VT225 Installation Guide - Describes the installation procedure for the VT225. This document is shipped with the terminal.
MP-02309-01	VT225 Field Maintenance Print Set.

Specifications

ANSI specifications are available from:

Sales Department
American National Standards Institute
1430 Broadway
New York, NY 10018

EIA specifications are available from:

Engineering Department
Electronic Industries Association
2001 Eye Street, NW
Washington, DC 20006

International standards are available from:

CCITT
UN Book Store
United Nations Building
New York, NY 10017

GENERAL

Illustrations of all national keyboards for the VT220 are shown in this appendix in the following order.

North American
United Kingdom
Belgium (Flemish)
Canada (French)
Denmark
Finland
France/Belgium
Germany/Austria
Holland
Italy
Norway
Spain
Sweden
Switzerland (French)
Switzerland (German)

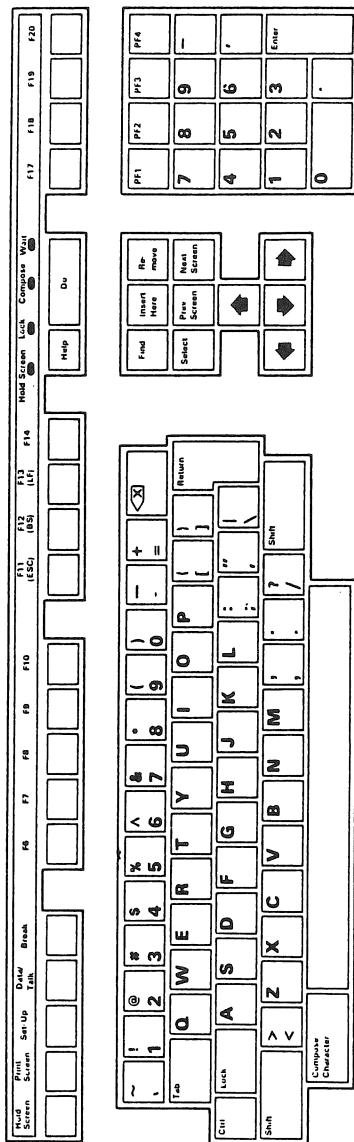

Figure C-1 North American

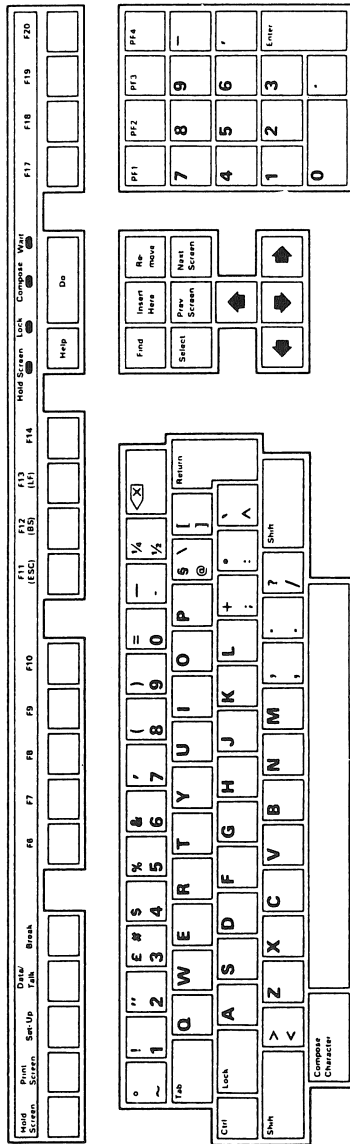

Figure C-2 United Kingdom

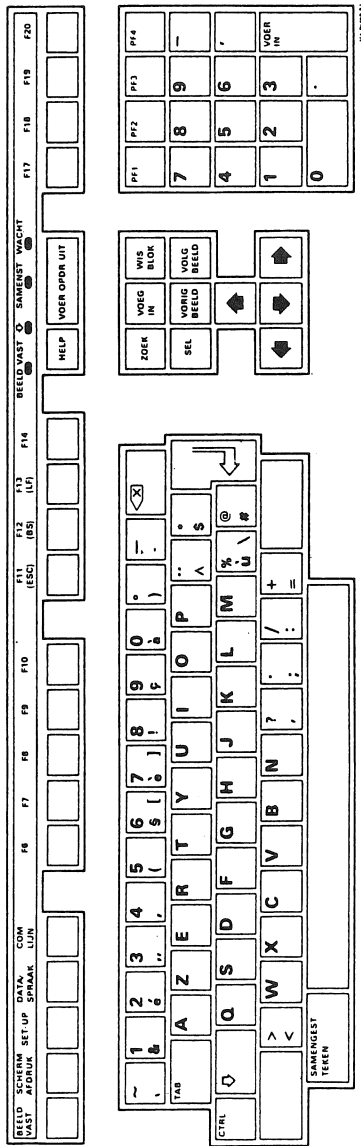

Figure C-3 Belgium (Flemish)

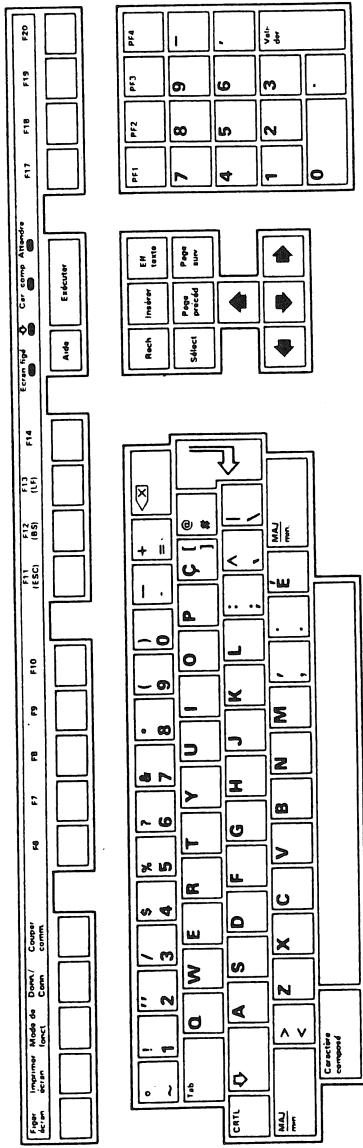

Figure C-4 Canada (French)

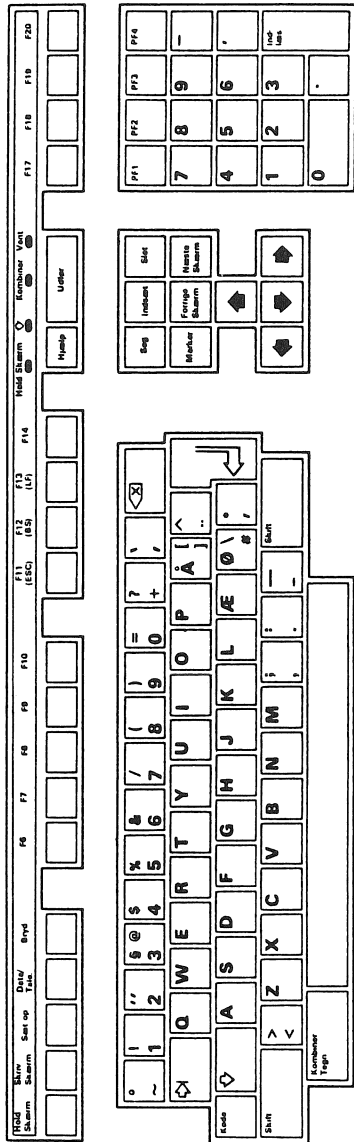

Figure C-5 Denmark

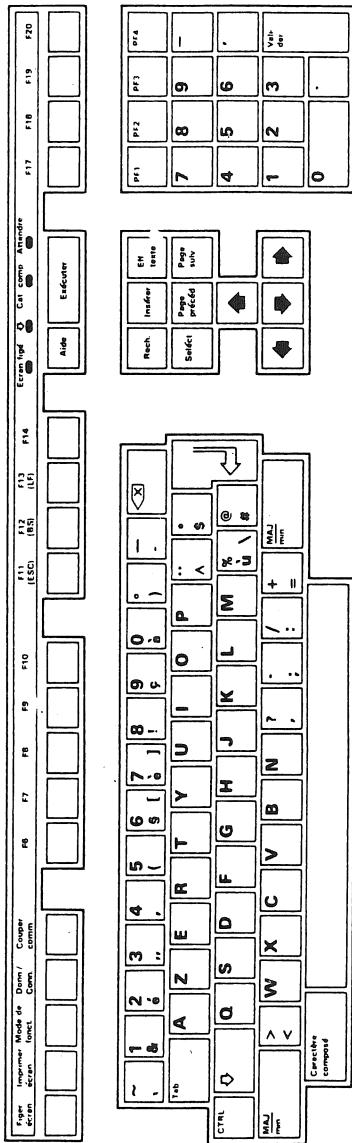

Figure C-7 France/Belgium

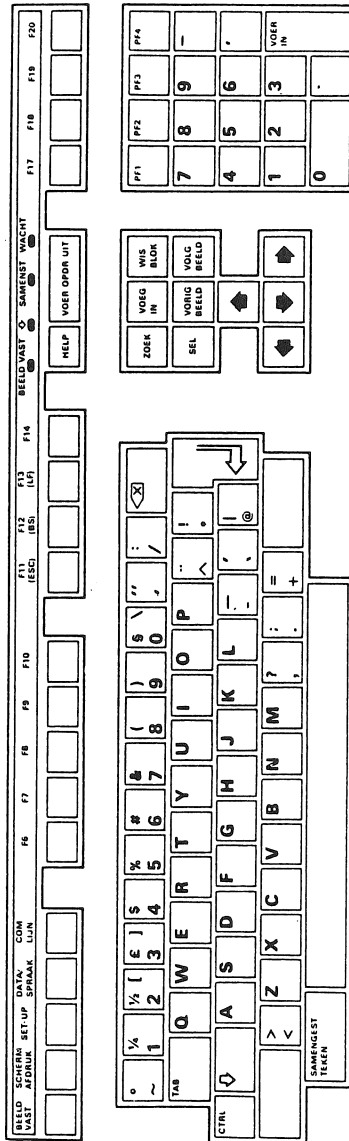

Figure C-9 Holland

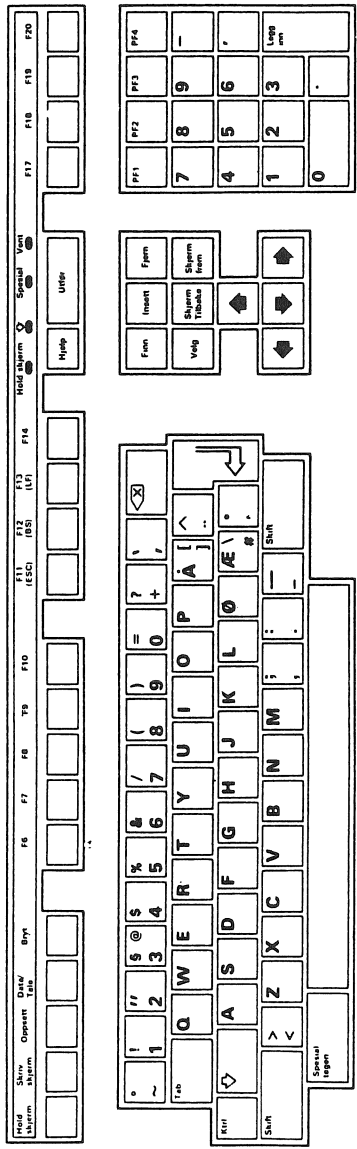

Figure C-11 Norway

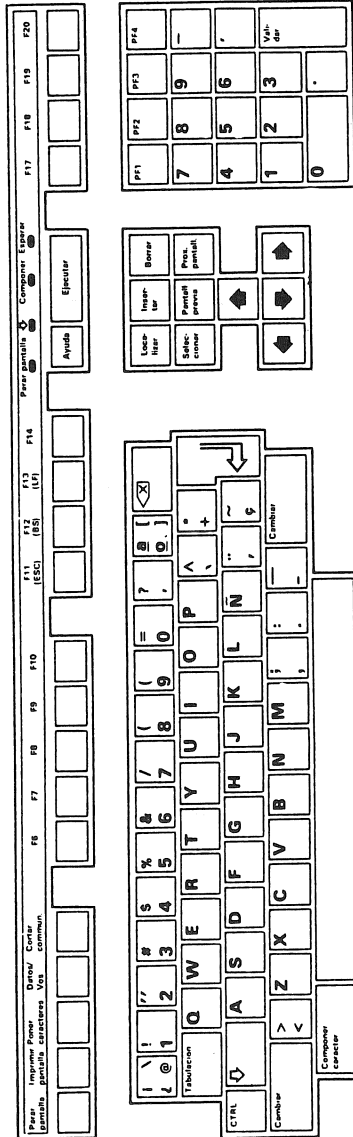

Figure C-12 Spain

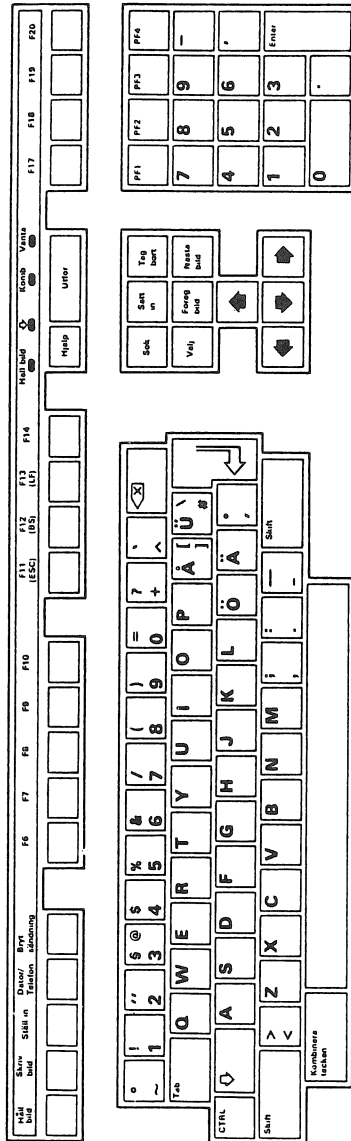

Figure C-13 Sweden

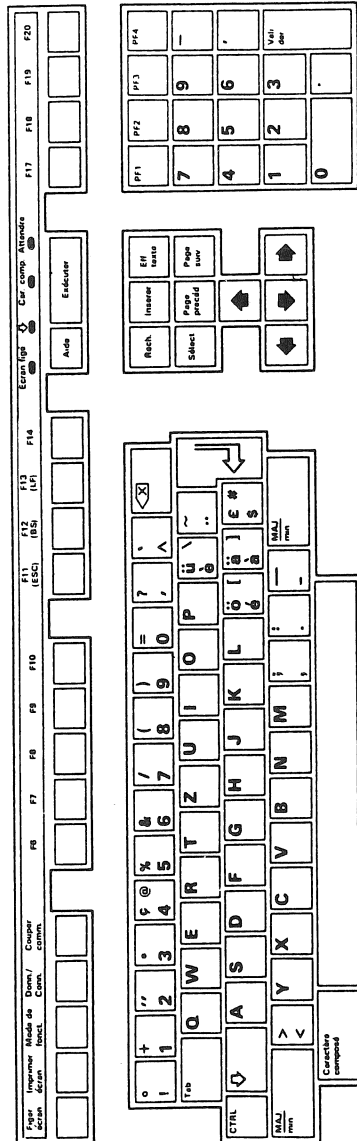

Figure C-14 Switzerland (French)

Manual Title:
VT225 USER'S MANUAL

READER'S COMMENTS

Dear Reader,

Your comments and suggestions will help us in our continuous effort to improve the quality and usefulness of our publications.

What is your general reaction to this manual?

	Excellent	Very Good	Good	Fair	Poor
Accuracy	<input type="checkbox"/>	<input type="checkbox"/>	<input type="checkbox"/>	<input type="checkbox"/>	<input type="checkbox"/>
Completeness	<input type="checkbox"/>	<input type="checkbox"/>	<input type="checkbox"/>	<input type="checkbox"/>	<input type="checkbox"/>
Organisation	<input type="checkbox"/>	<input type="checkbox"/>	<input type="checkbox"/>	<input type="checkbox"/>	<input type="checkbox"/>
Format	<input type="checkbox"/>	<input type="checkbox"/>	<input type="checkbox"/>	<input type="checkbox"/>	<input type="checkbox"/>

What features are most useful?

(Notes, Tables, Illustrations etc.) _____

Does the publication satisfy your needs?

Yes No

What errors have you found?

(Ref. Page No., Table No., Figure No.) _____

Additional Comments: _____

Name: _____ Title: _____

Company: _____ Department: _____

Address: _____

Copies of the above Manual are available by writing or calling:

digital

Digital Equipment Corporation (Australia) Pty. Limited,
Computer Special Systems,
Unit 1, 706 Mowbray Road,
LANE COVE, N.S.W. 2066.
Telephone: 02 412 5252.

Attention: Engineering Department

PLEASE FOLD HERE AND STAPLE WHERE INDICATED

No postage stamp
required if posted
in Australia

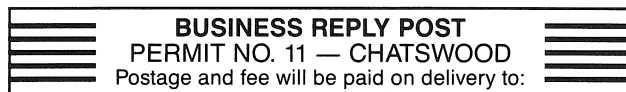

DIGITAL EQUIPMENT CORPORATION
(AUSTRALIA) PTY. LIMITED,
P.O. BOX 384,
CHATSWOOD, N.S.W., 2067.

Attention: C.S.S. Engineering

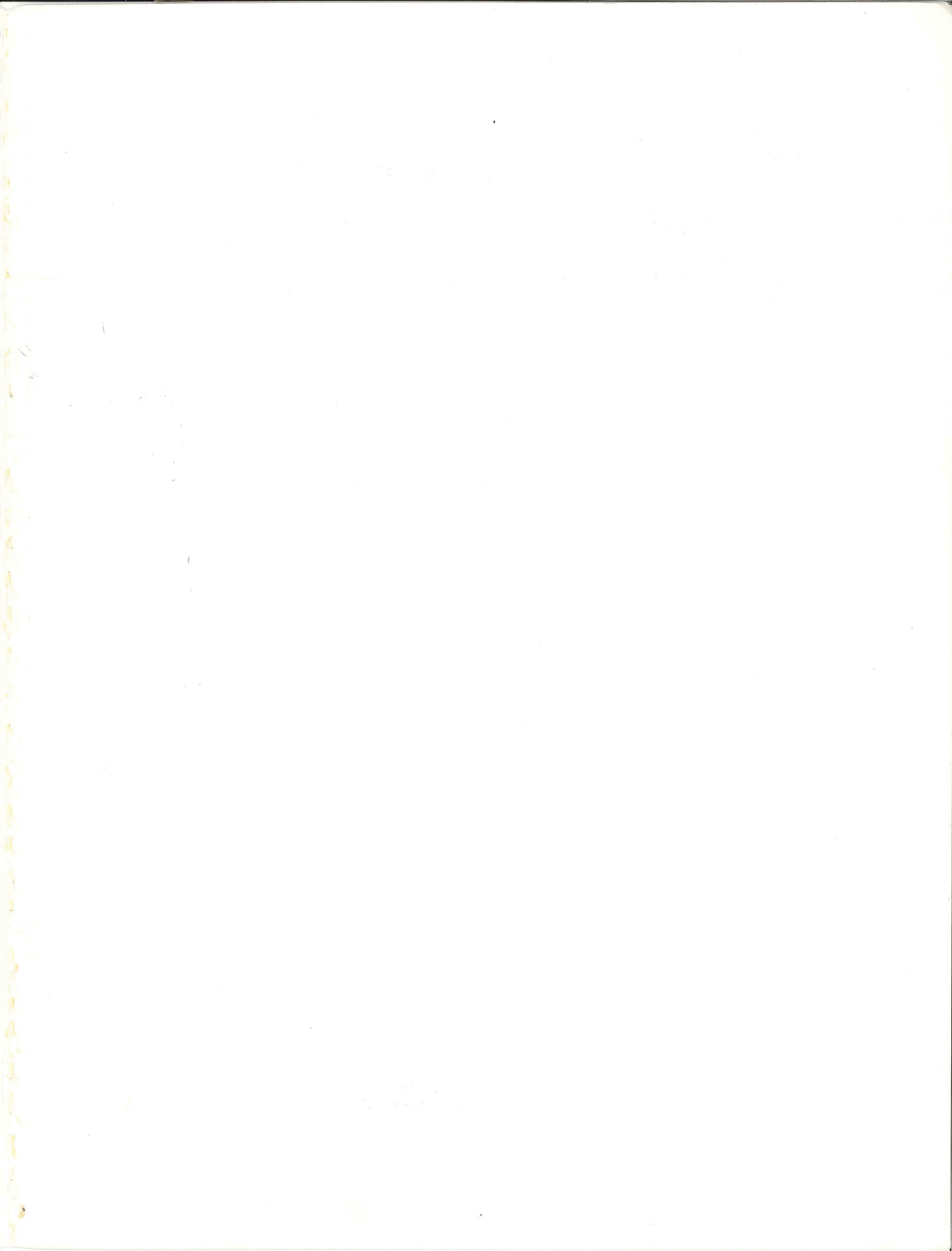



Printed in Australia
EK-VT225-UG-001