

digital

VT131

VIDEO TERMINAL
USER GUIDE

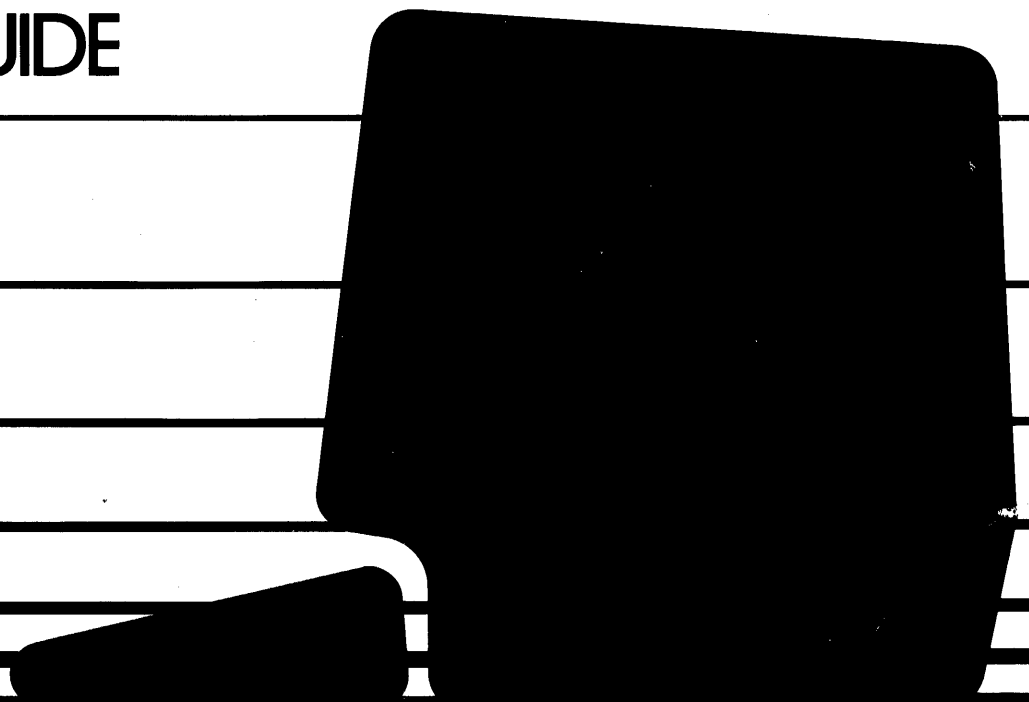

VT131

VIDEO TERMINAL
USER GUIDE

1st Edition, August 1981
2nd Edition, October 1981

Copyright © 1981 by Digital Equipment Corporation
All Rights Reserved

The Federal Communications Commission of the United States Government has published regulations which govern the allowable limits of emanation of radio frequency energy of computing devices and associated peripherals.

These regulations are concerned with interference to radio communication, such as radio and TV.

The regulations require equipment for end use in the United States to be labeled and to be accompanied by the notice appearing below.

To minimize the potential for interference, DIGITAL supplied interconnecting cables should be used.

Notice

This equipment generates and uses radio frequency energy. It has been type tested and found to comply with the limits for a Class B computing device in accordance with the specifications in Subpart J of Part 15 of FCC Rules, which are designed to provide reasonable protection against radio and television interference in a residential installation. However, there is no guarantee that interference will not occur in a particular installation. If this equipment does cause interference to radio or television reception, the user is encouraged to try to correct the interference.

German RFI-Suppression (VDE) Notification

Notice

RFI-suppressed according to German regulation 529/1970 and 227/1976 (VDE 0871 Class B).

High Speed Communication

Notice

In applications using continuous 19200 baud communication, occasional data errors may occur. When errors are detected, the characters in error are replaced by the substitute character (⌘). In these cases, lower speeds (baud rates) should be used.

Printed in U.S.A.

The following are trademarks of Digital Equipment Corporation, Maynard, Massachusetts.

DEC	Digital Logo	IAS	DIBOL
DECUS	DECsystem-10	MASSBUS	PDT
DIGITAL	DECSYSTEM-20	DECnet	RSTS
RSX	DECwriter	UNIBUS	PDP
VMS	EduSystem	OMNIBUS	VT
VAX	OS/8		

CONTENTS

CHAPTER 1 OPERATING INFORMATION

GENERAL.....	1-1
TERMINAL OPERATION.....	1-1
CONTROLS AND INDICATORS.....	1-4
Monitor Controls.....	1-4
Internal Communication Switches.....	1-6
Communication Switches.....	1-6
20 mA Current Loop Switches.....	1-6
Keyboard Controls.....	1-6
Standard Keys.....	1-6
Function Keys.....	1-9
Printing keys.....	1-12
Editing Keys.....	1-12
SET-UP Keys.....	1-17
Keyboard Indicators.....	1-20
Audible Indicators.....	1-24

CHAPTER 2 PRINTING

GENERAL.....	2-1
PRINT OPERATIONS.....	2-1
Auto Print (line at a time).....	2-1
Print Screen.....	2-3
Printer Controller.....	2-4
Print Cursor Line.....	2-4

CHAPTER 3 EDITING

GENERAL.....	3-1
EDIT MODE.....	3-1
SELECTING EDIT MODE.....	3-1
EDITING OPERATIONS.....	3-2
Character Protection.....	3-2
Moving The Cursor.....	3-2
Inserting a Line.....	3-3
Inserting a Character.....	3-3
Deleting a Line.....	3-7
Deleting a Character.....	3-11
Clearing the Screen.....	3-16
Transmitting Characters in Edit mode.....	3-16

CHAPTER 4 SET-UP FEATURES

GENERAL.....	4-1
SET-UP.....	4-1
SET-UP FEATURE SELECTION.....	4-1
SET-UP FEATURE MEMORIES.....	4-4
Operating Memory.....	4-4
User Permanent Memory.....	4-4
Store.....	4-6
Recall.....	4-6
Reset.....	4-8
Default Memory.....	4-9
General Default.....	4-9
Tab Default.....	4-12
SET-UP FEATURE TYPES.....	4-12
Operator Preference Features.....	4-12
Communication Compatibility Features.....	4-12
Editing Features.....	4-12
Installation Features.....	4-14
SET-UP FEATURE DESCRIPTIONS.....	4-14
General SET-UP Features.....	4-14
ON/OFF LINE.....	4-15
Screen Brightness.....	4-15
SET-UP A Features.....	4-17
Columns Per Line.....	4-17
Tabs.....	4-17
SET-UP B Features.....	4-21
Scroll.....	4-24
Auto Repeat.....	4-24
Screen Background.....	4-24
Cursor.....	4-26
Margin Bell.....	4-26
Keyclick.....	4-26
ANSI/VT52.....	4-26
Auto XON/XOFF (FDX).....	4-26
US/UK Character Set.....	4-27
Auto Wrap.....	4-27
Line Feed/New Line.....	4-27
Local Echo.....	4-28
Print Termination Character.....	4-28
Print Extent.....	4-28
1 or 2 Stop Bits.....	4-28
Receive Parity.....	4-30
Break Enable.....	4-30
Disconnect Character Enable.....	4-30
Disconnect Delay (FDX).....	4-30
Auto Answerback Enable.....	4-31
Initial Direction (HDX).....	4-31
Auto Turnaround (HDX).....	4-31
Power.....	4-31
WPS Terminal.....	4-31
Clock.....	4-31
Modem Data/Parity Bits.....	4-32

Modem Transmit Speed.....	4-34
Modem Receive Speed.....	4-34
Modem Control.....	4-35
Turnaround(End of Block Character)/Disconnect Character.....	4-37
Printer Data/Parity Bits.....	4-39
Printer Receive/Transmit Speed.....	4-40
Answerback.....	4-42
SET-UP C.....	4-44
Edit Mode.....	4-47
Edit Key.....	4-47
Guarded Area Transfer.....	4-47
Space Compression.....	4-47
Line Transmit.....	4-47
Transmit Termination.....	4-47
Transmit Execution.....	4-48
Bold Protected.....	4-48
Underline Protected.....	4-48
Blink Protected.....	4-48
Reverse Protected.....	4-48
Normal Protected.....	4-48
Erasure Mode.....	4-48
End of Line Character Enable.....	4-48
End of Line Character.....	4-49

CHAPTER 5 TRANSMITTED CHARACTERS

GENERAL.....	5-1
STANDARD KEYS.....	5-1
FUNCTION KEYS.....	5-1
AUXILIARY KEYPAD KEYS.....	5-4
TRANSMISSION OF CHARACTERS IN EDIT MODE.....	5-12

CHAPTER 6 RECEIVED CHARACTER PROCESSING

GENERAL.....	6-1
RECEIVED CHARACTERS.....	6-1
DISPLAYABLE CHARACTERS.....	6-1
CONTROL CHARACTERS.....	6-3
ESCAPE AND CONTROL SEQUENCES.....	6-3
Error Recovery.....	6-9
ANSI Compatible Sequences.....	6-9
SET-UP Features and Modes.....	6-9
ANSI/VT52 Compatibility.....	6-12
Scrolling.....	6-17
Scrolling Region.....	6-18
Origin.....	6-18
Cursor Positioning.....	6-19
Columns Per Line.....	6-22
Auto Wrap.....	6-22
Screen Background.....	6-23
Line Feed/New Line.....	6-23
Keyboard Action.....	6-25
Auto Repeat.....	6-25

Local Echo (Keyboard send-receive).....	6-26
Cursor Key Character Selection.....	6-26
Keypad Character Selection.....	6-28
Character Sets and Selection.....	6-28
Character Attributes.....	6-37
Tab Stops.....	6-38
Line Attributes.....	6-38
Erasing.....	6-39
Computer Editing.....	6-40
Character Insertion-Replacement.....	6-42
Local Editing (Edit mode).....	6-42
Edit Key Execution.....	6-43
Character Protected.....	6-43
Erasure mode.....	6-44
Transmit Execution.....	6-45
Transmission Request.....	6-46
Transmission Enable.....	6-46
Line Transmit.....	6-47
Transmit Termination.....	6-47
Space Compression/Field Delimiter.....	6-48
Guarded Area Transfer.....	6-49
Transmit Termination Character (End of Block).....	6-49
Printing.....	6-50
Printer Extent.....	6-52
Print Termination Character.....	6-52
Reports.....	6-52
Reset.....	6-54
Tests and Adjustments.....	6-55
VT52 Compatible Sequences.....	6-57
Mode Selection.....	6-57
ANSI/VT52 Compatibility.....	6-57
Keypad Character Selection.....	6-57
Character Sets and Selections.....	6-60
Cursor Positioning.....	6-60
Erasing.....	6-61
Printing.....	6-63
Reports	6-65

CHAPTER 7 COMMUNICATION

GENERAL.....	7-1
CONNECTING TO THE COMPUTER.....	7-1
Modem (Communication) Interface.....	7-5
Communication Switch Settings.....	7-5
Modem Serial Characters.....	7-5
Break Signal.....	7-5
Modem Control.....	7-10
Full Duplex Communication.....	7-10
Full Duplex with no Modem Control (FDX A)...	7-10
FDX A Connect Conditions.....	7-16
FDX A Disconnect Conditions.....	7-16
Full Duplex with Modem Control (FDX B).....	7-16
FDX B Connect Conditions.....	7-17

FDX B Disconnect Conditions.....	7-17
Asymmetric Full Duplex (FDX C).....	7-21
FDX C Connect Conditions.....	7-21
FDX C Disconnect Conditions.....	7-25
Half Duplex Communication.....	7-25
Half Duplex with Supervisory Control (HDX A).....	7-26
HDX A Connect Conditions.....	7-26
HDX A Character Transmission and Reception.....	7-30
HDX A Disconnect Conditions.....	7-31
Half Duplex with Coded Control (HDX B).....	7-31
HDX B Connect Conditions.....	7-36
HDX B Character Transmission and Reception.....	7-36
HDX B Disconnect Conditions.....	7-37
Input Buffer Overflow Prevention.....	7-37
XON/XOFF Control Characters.....	7-39
Fill Characters.....	7-40
Low Speed Operation.....	7-40
Effects of Reset and Test.....	7-40
Keyboard Transmit Buffer.....	7-42
CONNECTING TO THE PRINTER.....	7-42
Printer Interface.....	7-44
Printer Serial Characters.....	7-44

CHAPTER 8 INSTALLATION

GENERAL.....	8-1
SITE CONSIDERATIONS.....	8-1
UNPACKING AND INSPECTION PROCEDURE.....	8-4
PACKING PROCEDURE.....	8-4
INSTALLATION PROCEDURE.....	8-7
Input Voltage Range Selection.....	8-8
Internal Communication Switch Selection.....	8-9
Communication Cable Summary.....	8-9
POWER UP AND CHECKOUT PROCEDURE.....	8-16

CHAPTER 9 OPTIONS

GENERAL.....	9-1
20 MA CURRENT LOOP INTERFACE OPTION.....	9-1
OPTION INSTALLATION.....	9-1
OPTION CHECKOUT.....	9-8

CHAPTER 10 MAINTENANCE AND TROUBLESHOOTING

GENERAL.....	10-1
MAINTENANCE.....	10-1
TROUBLESHOOTING (WHAT TO DO IN THE EVENT OF A PROBLEM).....	10-1
SELF TESTS.....	10-5
Power Up Self-Test.....	10-5
Data Loopback Self-Test.....	10-7

EIA Loopback Self-Test.....	10-9
Printer Loopback Self-Test.....	10-10
Printer Test.....	10-12

CHAPTER 11 ACCESSORIES AND SUPPLIES

APPENDIX A VT131 SPECIFICATIONS

APPENDIX B SET-UP SUMMARY

APPENDIX C TRANSMITTED CHARACTER CODES

APPENDIX D PROGRAMMING SUMMARY

APPENDIX E CONTROL FUNCTIONS (SEQUENCE FORMATS)

APPENDIX F VT131/VT100 DIFFERENCES

Figures

1-1	On-Line General Block Diagram	1-2
1-2	Off-Line General Block Diagram (VT131)	1-3
1-3	Monitor Controls (VT131)	1-5
1-4	VT131 Terminal Keyboard	1-7
1-5	VT131 Standard Keys	1-8
1-6	VT131 Function Keys	1-10
1-7	VT131 Printing Keys	1-13
1-8	VT131 Editing Keys	1-14
1-9	VT131 SET-UP Keys	1-18
1-10	VT131 Keyboard Indicators	1-21
2-1	Local Printing Configuration (VT131)	2-2
3-1	Cursor Positioned to Add a Line to the Screen	3-4
3-2	Line Added to the Screen	3-5
3-3	Positioning the Cursor to Insert a Character ...	3-6
3-4	Character Inserted	3-8
3-5	Cursor Positioned to Delete a Line from the Screen	3-9
3-6	Line Deleted from the Screen	3-10
3-7	Positioning the Cursor to Delete a Character ...	3-12
3-8	Character Deleted	3-13
3-9	Positioning the Cursor to Correct a Typing Error	3-14
3-10	Error Corrected	3-15
4-1	SET-UP Displays	4-2
4-2	SET-UP Feature Memories (VT131)	4-5
4-3	Default Feature Selections	4-10
4-4	ON/OFF Line General Block Diagram (VT131)	4-16
4-5	SET-UP A Display	4-18
4-6	80 and 132 Columns Per Line (VT131)	4-19
4-7	SET-UP B Display (VT131)	4-22
4-8	SET-UP B Summary (VT131)	4-23
4-9	Screen Background	4-25

4-10	Local Echo	4-29
4-11	Answerback Message Summary (VT131)	4-43
4-12	SET-UP C Display	4-45
4-13	SET-UP C Summary	4-46
5-1	Standard Key Codes	5-2
5-2	VT131 Function Keys	5-3
5-3	Function Key Control Codes (VT131)	5-5
5-4	Space Compression/Field Delimiter and Guarded Area Transfer Mode Interaction	5-14
6-1	ASCII Table	6-2
6-11	United Kingdom Character Set (VT131)	6-32
6-12	United States Character Set	6-33
6-13	Special Character and Line Drawing Character Set (VT131)	6-34
7-1	Connecting to the Computer (VT131)	7-2
7-2	Modem connector Location and Pin Numbering (VT131)	7-6
7-3	Communication Switch Summary (VT131)	7-8
7-4	Serial Character Format (VT131)	7-9
7-5	Printer Connector Location and Pin Numbering (VT131)	7-45
8-1	Terminal Dimensions	8-2
8-2	Terminal Packing (VT131)	8-5
8-3	Monitor Controls and Connector Locations (VT131)	8-6
8-4	Access Cover Screw Locations (VT131)	8-10
8-5	Access Cover Removal (VT131)	8-11
8-6	Internal Communication Switch Locations (VT131)	8-12
8-7	Internal Communication Switch Selections (VT131)	8-13
8-8	Cable Summary (VT131)	8-15
9-1	20 mA Connector and Pin Locations (VT131)	9-2
9-2	Access Cover Screw Locations	9-4
9-3	Access Cover Removal	9-5
9-4	20 mA Board Location (VT131)	9-6
9-5	20 mA Board Configuration (VT131)	9-7
9-6	20 mA Loopback Connector (VT131)	9-9
10-1	Monitor Controls and Connector Locations	10-4
10-2	EIA Loopback Connector (Modem) (VT131)	10-8
10-3	EIA Loopback Connector (Printer) (VT131)	10-11
A-1	Composite Video Output (VT131)	A-5
B-1	SET-UP Displays	B-2
B-2	SET-UP Display Summary	B-4
C-1	Standard Key Codes	C-1
C-2	Function Key Control Codes	C-4

Tables

1-1	Causes of the Keyboard Locked Condition	1-23
4-1	SET-UP Features That Can Be Changed by the Computer	4-7
4-2	SET-UP Feature Types	4-13

4-3	Modem Data/Parity bits Selection	4-33
4-4	Modem Control Selections	4-36
4-5	Turnaround (End of Block)/Disconnect Character Selections	4-38
4-6	Printer Data/Parity Bits Selections	4-41
5-1	Cursor Control Key Codes	5-6
5-2	Control Codes Generated	5-7
5-3	VT131 and Previous DEC Terminal Key Differences	5-9
5-4	Keypad Codes	5-10
6-1	American Standard Code for Information Interchange (ASCII)	6-2
6-2	Control Characters Recognized by VT131 Terminal	6-4
6-3	Escape and Control Sequence Arrangement	6-6
6-4	SET-UP Features and Modes	6-10
6-5	ANSI Specified Modes	6-13
6-6	ANSI Compatible Private Modes	6-14
6-7	Permanently Selected Modes	6-15
6-8	Line Feed/New Line Feature	6-24
6-9	ANSI Cursor Control Key Codes	6-27
6-10	ANSI Keypad Codes	6-29
6-11	United Kingdom Character Set	6-32
6-12	United States Character Set	6-33
6-13	Special Character and Line Drawing Character Set	6-34
6-14	VT52 Keypad Codes	6-58
6-15	Special character and Line Drawing Set and Graphics Mode Comparison	6-61
7-1	Possible Bell Modem Configurations (Public Switched)	7-3
7-2	Possible Bell Modem Configurations (Dedicated Line)	7-4
7-3	Factory Configured Communication Switch Selections	7-7
7-4	Modem Control Feature Selections	7-11
7-5	Possible Modem Protocol Feature and Modem Configurations	7-12
7-6	Modem Signals in Full Duplex Data Leads Only (FDX A)	7-14
7-7	Full Duplex with Modem Control (FDX B)	7-18
7-8	Asymmetric Full Duplex with Modem Control (FDX C)	7-22
7-9	Half Duplex with Supervisory Control (HDX A)	7-27
7-10	HDX A Modem Control Line Summary	7-32
7-11	Half Duplex Using Coded Control (HDX B)	7-33
7-12	HDX B Modem Control Line Summary	7-38
7-13	Suggested Fill Character Requirements	7-41
7-14	Applicable DEC Serial Printers	7-43
7-15	Printer Interface Signals	7-46
8-1	Site Considerations	8-3
8-2	Interface Cables	8-14
10-1	Problem Checklist	10-2
C-1	Cursor Control Key Codes	C-3
C-2	Control Codes Generated	C-4
C-3	Auxiliary Keypad Codes	C-6

INTRODUCTION

PRODUCT INTRODUCTION

The VT131 is a video terminal which uses a keyboard and display to communicate with a computer. The terminal performs two functions, it is an input and output device of the computer. As an input device, the VT131 can operate as either an interactive or editing terminal. As an editing terminal, the VT131 provides local editing, protected and unprotected fields and block transmission of edited characters.

At the same time, the VT131 terminal is also an output device. As an output device of the computer, the terminal displays received characters on the video screen using advanced video features or prints the characters using a printer interface provided with the terminal. The printer interface, when connected to an optional serial printer to provide printed copy without the need for a separate communication line and interface to the computer.

HOW TO USE THIS BOOK

This user guide provides general operating information, interface information, control function descriptions, and specific installation and checkout procedures. The main audiences for this book are the terminal installer, the application programmer and the operator. The operator however should use this book only as a reference when operating the terminal. The document which describes the use of the application software is the primary document for the operator. The application software (program) determines how the computer and terminal operate.

The information in this book is divided by function. This allows you to reference a specific chapter according to the function to be performed. Also, the chapters are arranged by frequency of use. For example, the operating information is most frequently used by the operator, therefore it is at the beginning of the book. However, installation is usually performed once, therefore it is toward the back of the book.

The book is divided into the following chapters:

Chapter 1 Operating Information provides a general introduction of how the terminal operates and shows all the controls and indicators of the terminal. This chapter also describes the general operating procedures. Detailed operating information depends on the computer and its software.

Chapter 2 Printing describes the printing operations which can be performed with an optional serial printer. The chapter also provides the keyboard procedures used to select the printing operations.

Chapter 3 Editing describes the keyboard editing procedures performed in edit mode. Also, this chapter describes the keyboard procedure used to start transmission of edited information to the computer.

Chapter 4 SET-UP Features defines SET-UP and describes each SET-UP feature in detail. The procedure to select each feature is also provided in this chapter. Many of the SET-UP features alter the way the terminal communicates with the computer. Detailed information on communication and the related SET-UP features is provided in Chapter 7.

Chapter 5 Transmitted Characters describes the characters transmitted by the terminal and illustrates the keys used to generate these characters. Also, this chapter provides an overview of block character transmission while in edit mode.

Chapter 6 Received Character Processing describes how the terminal processes received characters. The use of control functions to control the display, processing, transmission and representation of characters by the terminal is also described. This chapter is generally used by the application programmer when creating applications software used with this terminal.

Chapter 7 Communication describes how the terminal communicates with the computer and printer using the modem and printer interface. descriptions of the communication features are also included.

Chapter 8 Installation describes the environmental conditions which should be considered before installing the terminal. A detailed unpacking and installation procedure is provided. The chapter also contains a step-by-step procedure for power up and checkout (verify) the proper operation of the terminal.

Chapter 9 Options describes the 20 mA current loop interface option and also provides installation and checkout instructions.

Chapter 10 Maintenance and Troubleshooting describes all maintenance and troubleshooting procedures used before requesting service. The troubleshooting information describes the self tests of the terminal.

Chapter 11 Accessories and Supplies Information describes the accessories and supplies used with the VT131 terminal. Included in this chapter is a brief description of each accessory and supply, part number and ordering information.

Appendix A describes the detailed specifications of the VT131 terminal.

Appendix B provides a summary of the SET-UP feature displays.

Appendix C provides a summary of the codes generated by the VT131 terminal.

Appendix D provides a summary of the VT131 programming control functions.

Appendix E describes the ANSI code extension techniques used to create the escape and control sequences used by the VT131 terminal.

Appendix F describes the differences between the VT131 and VT100 terminals.

WARNINGS, CAUTIONS AND NOTES

In this book warnings, cautions and notes are use for specific purposes. Warnings highlight information used to prevent personal injury. Cautions highlight information used to prevent damage the terminal, and notes are used to highlight general information.

CHAPTER 1
OPERATING INFORMATION

GENERAL

This chapter provides a general introduction of how the VT131 terminal operates. A description of the all the controls and indicators and the general operating procedures is also provided. Detailed operating information depends on the computer and its application software.

TERMINAL OPERATION

The VT131 is a video terminal which uses a keyboard and display to communicate with a computer. The terminal can only communicate with the computer while on-line. Figure 1-1 shows a general block diagram of the VT131 terminal when on-line. When on-line the terminal performs two functions, it is an input and output device of the computer. As an input device, the VT131 can operate as either an interactive or editing terminal. When operating as an interactive terminal, all keyboard entries generate characters placed in a keyboard character buffer for transmission. The character is then taken from the buffer and transmitted. When operating as an editing terminal all keyboard entries are display on the screen. All necessary changes can be made to the characters on the screen using the editing features before transmitting the characters to the computer. The transmission of the edited characters to the computer is performed when requested by the keyboard or computer.

At the same time, the VT131 terminal is also an output device of the computer. Characters received by the terminal are placed in the input character buffer until processed. When processed, the received characters are taken from the buffer and displayed on the screen. The terminal displays received characters on the screen using advanced video features. Characters received can also be printed using the printer interface provided with the terminal. An optional serial printer is connected to the printer interface to provide printed copy without the need for a separate communication line and interface to the computer.

When the terminal is off-line, it can not communicate with the computer. The terminal is disconnected from the communication line (phone line) and calls on the communication line are not answered. Characters typed on the keyboard are displayed on the screen. Figure 1-2 shows a general block diagram of the VT131 terminal while off-line.

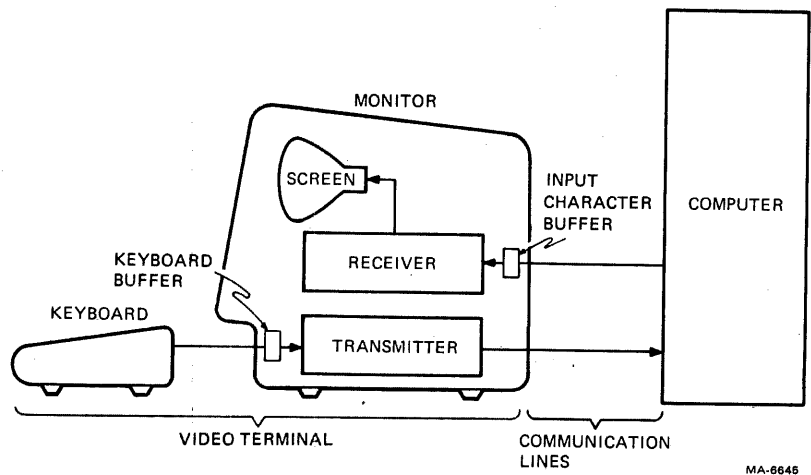

MA-6645

Figure 1-1 On-Line General Block Diagram

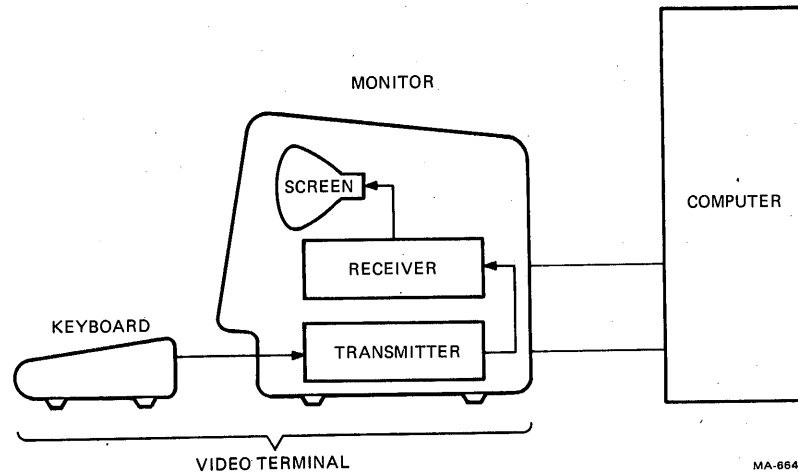

MA-8644

Figure 1-2 Off-Line General Block Diagram

NOTE: When the VT131 terminal is on or off-line, characters on the screen can be transmitted to the serial printer.

CONTROLS AND INDICATORS

The VT131 terminal has many different controls and indicators. The controls and indicators are described in five groups: monitor controls, keyboard controls, communication switches, visual indicators, and audible indicators.

Monitor Controls

The VT131 terminal has two controls mounted on the back panel of the monitor. The controls are the voltage selection switch and the power switch. The locations of these controls are shown in Figure 1-3. The following paragraphs describe the two monitor controls.

Voltage Selection switch -- The voltage selection switch allows the terminal to operate with the available ac input voltage range. When the switch position is changed, the fuse must also be changed. The switch and fuse are selected when the terminal is installed. Refer to the Chapter 8 for more information about installing the terminal.

CAUTION: Failure to select the proper voltage selection switch position and fuse may damage the terminal.

Power switch -- The power switch turns the ac power to the terminal on and off. When the ac power is on, either the ON LINE or OFF LINE keyboard indicator is on. Refer to the Indicators section of this chapter for more information about the keyboard indicators.

To turn on (power up) the terminal use the following procedure.

1. Turn the power switch on (Figure 1-3). The terminal automatically runs a power up self-test to verify that the terminal is operating correctly. The test provides the following indications.

^ All keyboard indicators turn on and off, and either the ON LINE or OFF LINE indicator is turned on.

NOTE: The other keyboard indicators may or may not be on depending on the communication signals received on the modem interface connector and the feature selections of the terminal.

^ A bell tone is generated.

^ The cursor is display in the upper-left corner of the screen.

Any error found by the power up self test is indicated by: the terminal not performing the above sequence, a character(s) displayed on the screen, or by several bell tones. Refer to Chapter 10 if the terminal does not power up correctly.

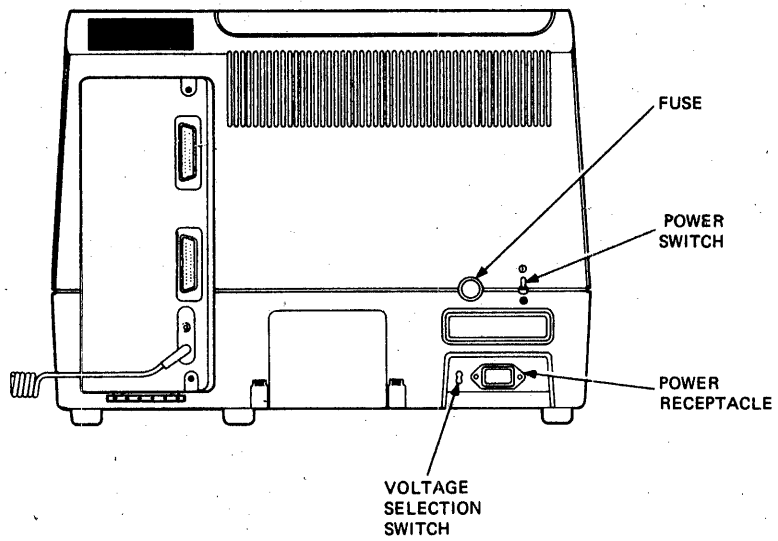

MA-8675D

Figure 1-3 Monitor Controls

Internal Communication Switches

The VT131 terminal has two types of internally mounted switches. The switches are communication switches and 20 mA current loop option switches. The following paragraphs describe the two types of switches.

Communication Switches -- The terminal has ten internally mounted communication switches. These communication switches determine which communication lines are used by the modem connector on the back panel of the terminal. These switches are selected during installation. Refer to Chapter 8 for the procedure used to select these switches.

20 mA Current Loop Switches -- The 20 mA current loop option (VT1XX-CA) is mounted within the terminal. The option has two switches to determine if the 20 mA current loop option is active or normal (passive) during operation. Refer to Chapter 9 for more information about the 20 mA current loop option.

Keyboard Controls

The VT131 terminal keyboard has a main keyboard and auxiliary keypad as shown in Figure 1-4. The main keyboard is arranged and operates similar to a standard office typewriter. The auxiliary keypad is arranged for rapid entry of numeric data, function characters (used with some application software) or editing commands. The keyboard keys are divided into five groups: standard keys, function keys, printing keys, editing keys and SET-UP keys. The standard and printing keys operate the same when operating as either an interactive or editing terminal.

Standard Keys -- Figure 1-5 identifies the keys on the keyboard that are labeled as standard typewriter keys. The computer can select the auxiliary keypad keys to generate the same unshifted characters as the minus, comma, period and numeric keys on the main keyboard.

The **CAPS LOCK** and **SHIFT** keys change the standard key characters generated by the main keyboard. Therefore, the **SHIFT** and **CAPS LOCK** keys are described in the following paragraphs. All the characters generated by the standard keys are listed in Chapter 5.

SHIFT Keys

When either of the **SHIFT** keys are pressed, the standard keys on the main keyboard generate uppercase characters. The characters generated by the auxiliary keypad are not affected by the **SHIFT** key.

NOTE: The **SHIFT** keys may also be used with the function, printing, editing and SET-UP keys. Refer to the appropriate sections of this chapter for more information about the use of the **SHIFT** key with these keys.

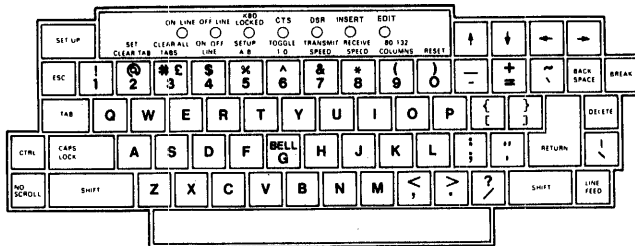
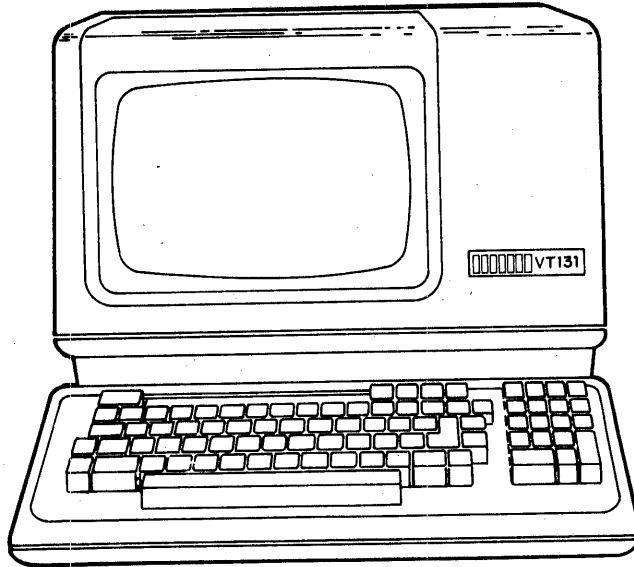

MAIN KEYBOARD

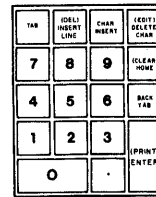

AUXILIARY KEYPAD

MA-7813B

Figure 1-4 VT131 Terminal Keyboard

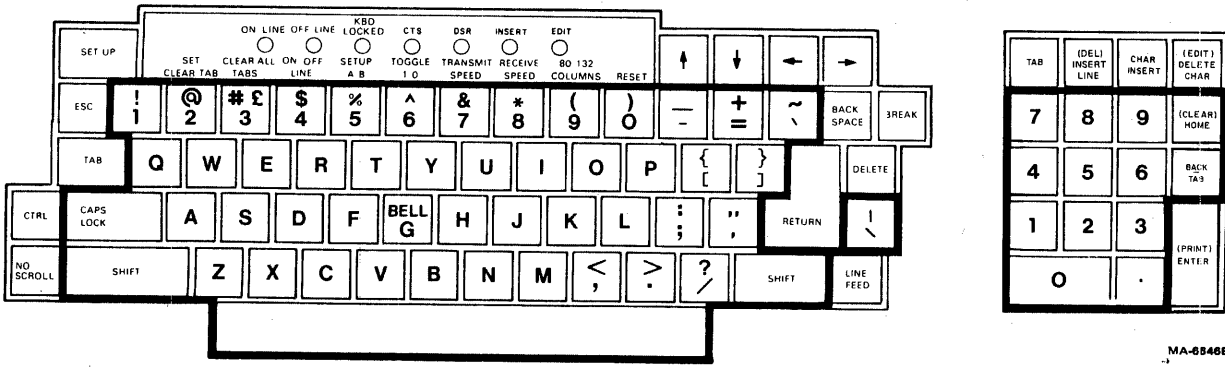

MA-6546B

Figure 1-5 VT131 Standard Keys

CAPS

LOCK Key

The **CAPS LOCK** key is a two position locking key. When locked in the down position, the alphabetic keys generate uppercase characters. When in the up position, the alphabetic keys generate lowercase character codes. The **CAPS LOCK** key does not affect the function and auxiliary keys.

NOTE: The numeric and special symbol keys are not affected by the **CAPS LOCK** key. Therefore, the **CAPS LOCK** key does not operate like the **SHIFT LOCK** key of a typewriter.

Function Keys -- Figure 1-6 identifies the interactive function keys of the terminal. When operating as an interactive terminal, these keys are used to generate function characters for transmission to the computer. The use of these characters is defined by the computer application software or communication system. The computer can select the auxiliary keypad to generate function characters. When the auxiliary keypad is used to generate function characters, the use of these characters is defined by the application software.

All the characters generated by the function keys are listed in Chapter 5. However, the following paragraphs provide a general description of each function key.

NO

SCROLL Key

The **NO SCROLL** key is used to control scrolling in the terminal. Scrolling is the upward or downward movement of existing lines on the screen to allow new lines to be added to the screen. When this key is first pressed, characters can not be added to the screen and scrolling is stopped; when pressed again, characters can be added to the screen and scrolling can continue.

NOTE: The **NO SCROLL** key operates only in full duplex communication with the auto **XON/XOFF SET-UP** feature on. If half duplex communication or full duplex communication with the auto **XON/XOFF** feature off is selected, this key does not function. Refer to Chapter 4 for more information about the auto **XON/XOFF SET-UP** feature.

BREAK Key

The **BREAK** key generates a Break signal when the break enable **SET-UP** feature is on. When the break enable feature is off, the Break signal is not generated by the terminal. Refer to Chapter 4 for more information about the **SET-UP** features and Chapter 7 for more information about the Break signal.

When the **SHIFT** key is down, the **BREAK** key generates a long break disconnect. With some modems, the long break disconnect causes a communication line disconnect (hang up the phone). Refer to Chapter 7 for more information about a long break disconnect.

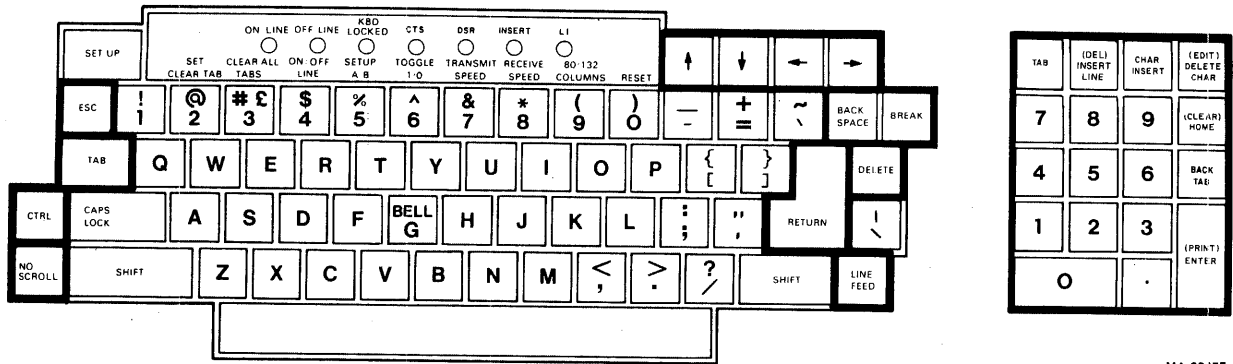

MA-6647E

Figure 1-6 VT131 Function Keys

When the CTRL key is down, the BREAK key generates the answerback message. The answerback message is used to identify the terminal to the computer. The answerback message is entered in SET-UP. Refer to Chapter 4 for more information about the answerback SET-UP feature.

↑ ↓ > < Keys

The use of these keys is determined by the application software. However, these keys usually generate cursor control commands. The cursor is an indicator on the screen that shows the line and column where the next character is displayed.

ESC Key

The ESC key generates the escape (ESC) character. The use of the escape character is determined by the application software.

TAB key

The TAB key generates the tab (TAB) character. The use of the tab character is determined by the application software.

CTRL Key

While the CTRL key is down, pressing another key may generate a control character. The use of each character is defined by the application software. The control characters generated are listed in Chapter 5.

NOTE: The CTRL key is also used with the BREAK and printing keys. Refer to the BREAK key description and the Printing Keys section of this chapter for more information about the use of these keys with the CTRL key.

BACK

SPACE key

The BACKSPACE key generates the backspace (BS) character. The use of the backspace character is determined by the application software.

DELETE Key

The DELETE key generates a delete (DEL) character. The use of the delete character is determined by the application software.

RETURN Key

The RETURN key generates either a carriage return (CR) or the carriage return (CR) and line feed (LF) characters. The characters generated by the RETURN key are selected using the line feed/new line SET-UP feature. Refer to Chapter 4 for more information about the line feed/new line SET-UP feature.

When half duplex coded control (HDX B) is selected by the modem control SET-UP feature, the RETURN key may also automatically generate the line turnaround character. Automatic generation of the turnaround character is selected by the auto turnaround SET-UP feature. The turnaround character generated is selected by the turnaround/disconnect character SET-UP feature. Refer to Chapter 4 for more information about the SET-UP features.

LINE

FEED Key

The **LINE FEED** key generates a line feed (LF) control character code. The use of the line feed character is determined by the application software.

Printing Keys -- Figure 1-7 identifies the keys used to control printing performed by the optional serial printer. Printing can be performed when operating as either an interactive or editing terminal when either on or off-line. The following paragraphs provide a general description of the printing keys. Refer to the Chapter 2 for more information about the printing operations performed by the terminal when connected to a serial printer.

NOTE: The printing control keys on the terminal do not cause the transmission of characters to the computer.

(PRINT)

ENTER Key

The **(PRINT)/ENTER** key of the auxiliary keypad is used with the **CTRL** and **SHIFT** keys to control printing performed by the serial printer. When the **CTRL** key is down, the **(PRINT)** key turns on and off auto print (line-at-a-time printing) operation. When a **SHIFT** key is down, the **(PRINT)** key selects the print screen operation.

Editing Keys - Figure 1-8 identifies the function keys of the VT131 used in edit mode. The 0 through 9 keys of the auxiliary keys cause the generation of the same character as the corresponding numeric key of the main keyboard. The following paragraphs briefly describe each editing key.

NOTE: Chapter 3 provides a description of edit mode and the step-by-step procedures used when editing. Read Chapter 3 before using the editing keys.

NO

SCROLL Key

The **NO SCROLL** key is used to stop characters from being displayed on the screen. When first pressed characters can not be added to the screen and scrolling is stopped; when pressed again, characters can be added to the screen.

NOTE: The NO SCROLL key operates only in full duplex communication with the auto XON/XOFF SET-UP feature on. If half duplex communication or full duplex communication with the auto XON/XOFF feature off is selected, this key does not function. Refer to Chapter 4 for more information about the auto XON/XOFF SET-UP feature.

BREAK Key

The **BREAK** key does not function in edit mode.

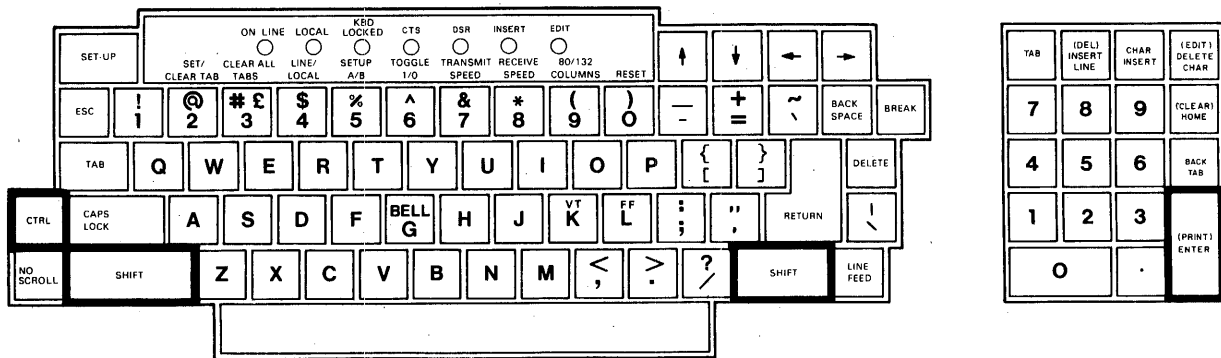

MA-9386A

Figure 1-7 VT131 Printing Keys

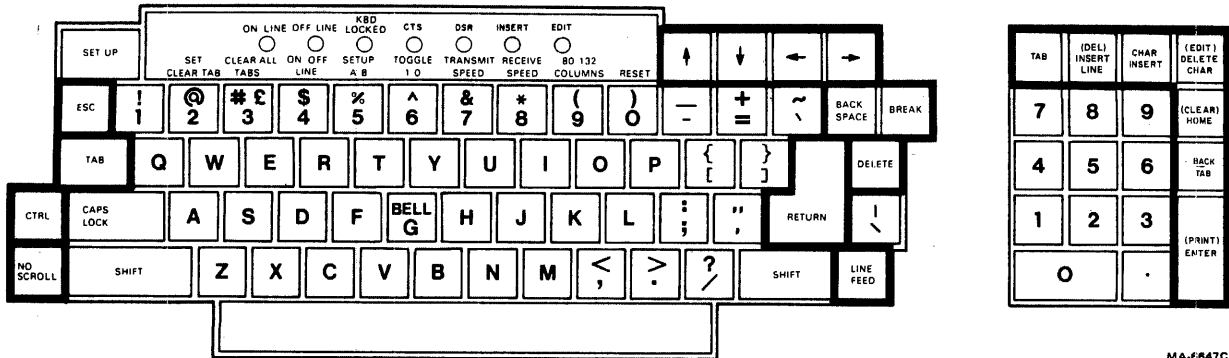

MA-6647C

Figure 1-8 VT131 Editing Keys

↑ ↓ > < Keys

These keys move the cursor control in the direction indicated on the keycap. These keys will not move the cursor outside the margins and will not cause scrolling.

ESC Key

The ESC key does not function in edit mode.

CTRL Key

While the CTRL key is down, pressing another key generates a control character. The control characters generated are listed in Chapter 5. However, the XON and XOFF control characters can not be generated from the keyboard in edit mode. The use of each character depends on how the terminal processes the character. Refer to Chapter 7 for more information on how the control characters are processed.

NOTE: The CTRL key is also used with the printing keys. Refer to the Printing Keys section of this chapter for more information about the use of these keys with the CTRL key.

BACK

SPACE key

The BACKSPACE key moves the cursor to the left one character position.

RETURN Key

The RETURN key moves the cursor to the first column of the next line. This key can also be used to start the transmission of characters to the computer when line transmit mode is selected in SET-UP. Refer to Chapter 4 for more information about the SET-UP features.

LINE

FEED Key

The LINE FEED key moves the cursor to the next line maintaining the current column position.

DELETE key

The DELETE key removes the character to the left of the cursor. The characters within the field to the right of the deleted character move left.

TAB key

The TAB key of both the main keyboard and the auxiliary keypad move the cursor forward to the start of whichever of these positions is found first:

- ^ the next unprotected field
- ^ the next tab position
- ^ the bottom margin

DELETE
CHAR key
(EDIT)

The **DELETE CHAR** key erases the character indicated by the cursor. Characters within the field to the right of the deleted character move left.

When the **SHIFT** key is down, the **(EDIT)** key switches the terminal between interactive and edit modes. The **EDIT** keyboard indicator is on when the terminal is in edit mode. The **EDIT** keyboard indicator is off when the terminal is in interactive mode.

INSERT
LINE key
(DELETE
LINE)

The **INSERT LINE** key causes a new line consisting of spaces to be added at the cursor. This key has no effect when there is a protected field on the current line.

When the **SHIFT** key is down, the **(DELETE LINE)** key removes the line at the cursor from the screen. All of the remaining lines move one line up and a new line of spaces is placed at the bottom margin. This key has no effect when there is a protected field on the current line.

CHAR
INSERT key

The **CHAR INSERT** key switches between insert and replace mode. These modes determine how characters are added to the screen. When the **INSERT** keyboard indicator is on, the terminal is in insert mode. Characters added to the screen cause existing characters move to the right. Characters moved past the right margin or into a protected field are lost.

When the **INSERT** keyboard indicator is off, the terminal is in replace mode. All characters added to the screen replace the characters on the screen.

(CLEAR)
HOME key

The **HOME** key causes the cursor to move to the first line and first column of the scrolling region. The scrolling region is the area between the top and bottom margin.

When the **SHIFT** key is down, the **(CLEAR)** key removes all unprotected characters on the video screen and moves the cursor to the start of the first unprotected field.

BACK

TAB key

When pressed the BACK TAB key causes the cursor to move back to whichever of these is found first:

- ^ the start of the current unprotected field
- ^ the previous unprotected field
- ^ the last tab position

(PRINT)

ENTER key

This key controls the transmission of characters to the computer and printer while in edit mode. The ENTER key starts the transmission of the characters on the screen to the computer.

NOTE: The (PRINT) is used with the CTRL and SHIFT keys to control printing performed by the serial printer.

SET-UP Keys -- Figure 1-9 identifies the keys used while operating in SET-UP. SET-UP is used to select features of the terminal from the keyboard. SET-UP is divided into SET-UP A, SET-UP B and SET-UP C. These SET-UP displays show a summary of feature selections. The following paragraphs describe the keys used in SET-UP.

NOTE: Chapter 4 provides both SET-UP feature descriptions and step-by-step feature selection procedures. Read Chapter 4 before using the SET-UP keys.

SET-UP Key

The SET-UP key places the terminal in SET-UP. While in SET-UP the VT131 terminal SET-UP features can be changed.

SET/CLEAR @

TAB 2 Key

In SET-UP A, the SET/CLEAR TAB key sets or clears individual horizontal tabs in the terminal. This key does not function in SET-UP B and SET-UP C.

CLEAR ALL # L

TABS 3 Key

In SET-UP A, the CLEAR ALL TABS key clears all horizontal tab stops set in the terminal. This key does not function in SET-UP B and SET-UP C.

ON/OFF \$

LINE 4 Key

In any SET-UP display, the ON/OFF LINE key switches the terminal between on-line and off-line. While on-line the terminal can transmit and receive characters. While off-line the terminal can not transmit or receive characters and keyboard entries are displayed on the screen.

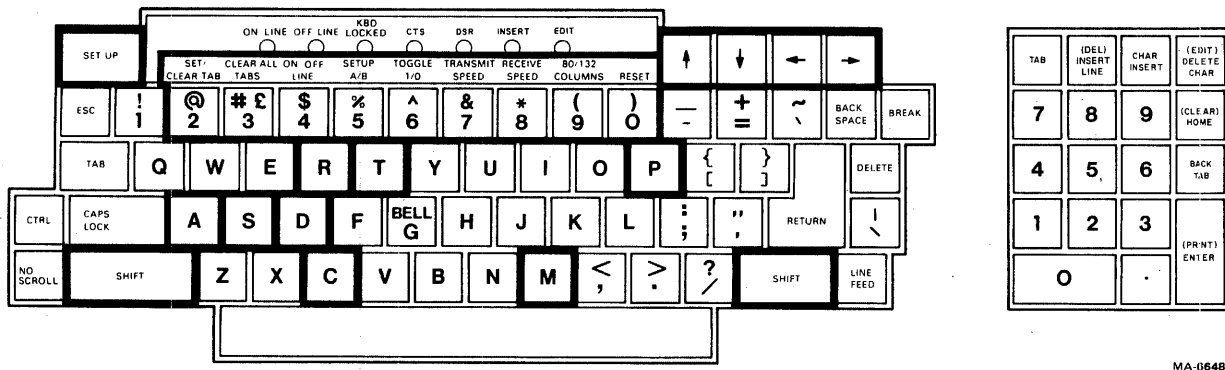

Figure 1-9 VT131 SET-UP Keys

MA-0648B

SET-UP A/B/C §
 5 Key
In any SET-UP display, the SET-UP A/B/C key switches the terminal between SET-UP A, SET-UP B and SET-UP C.

TOGGLE 1/0 ^
 6 Key
In SET-UP B and SET-UP C, the TOGGLE 1/0 key changes the feature selected by the cursor. This key does not function in SET-UP A.

TRANSMIT &
SPEED 7 Key
In SET-UP B, the TRANSMIT SPEED key selects the transmit speed (baud rate) used by the terminal. This key does not function in SET-UP A and SET-UP C.

RECEIVE *
SPEED 8 Key
In SET-UP B, the RECEIVE SPEED key selects the receive speed (baud rate) used by the terminal. This key does not function in SET-UP A and SET-UP C.

80/132 (
COLUMNS 9 Key
In SET-UP A, the 80/132 COLUMN key selects the display line size. The display line size is either 80 and 132 columns per line. This key does not function in SET-UP B and SET-UP C.

)
RESET Ø Key
In any SET-UP display, the RESET key starts the reset sequence. The reset sequence has the same result as turning the power switch off and then on.

↑ ↓ Keys
In any SET-UP display, the ↑ (up arrow) and ↓ (down arrow) keys increase and decrease the brightness of the display.

← → Keys
In any SET-UP display, the ← (left arrow) and → (right arrow) keys move the cursor left and right. In SET-UP B, the arrow keys are used with the SHIFT key to allow either the modem or printer interface features to be selected. When the SHIFT key is down, the ← (left arrow) key allows the modem interface features to be selected and the → (right arrow) key allows the printer interface features to be selected.

A Key
In SET-UP B, when the SHIFT key is down, press the A key and release both keys to create an answerback message. The answerback message is an identifying message stored within the terminal for transmission to the computer. The answerback message in the terminal must match the message expected by the computer. When entering this message into the terminal, all keyboard keys can be used.

C Key

In SET-UP B, when the **SHIFT** key is down, press the **C** key and release both keys to select the turnaround character. The turnaround character is used in half duplex communication with coded control turnaround (HDX B).

D Key

In any SET-UP display, when the **SHIFT** key is down, press the **D** key to select the default SET-UP feature selections. The default feature selections are typical SET-UP feature selections held within the terminal. The actual default selections are described in Chapter 4.

M Key

In SET-UP B, when the **SHIFT** key is down, press the **M** key and release both keys to select the type of communication used by the terminal. The terminal can use one of five types of communication. There are three types of full duplex communication and two types of half duplex communication.

P Key

In SET-UP B, when the **SHIFT** key is down, press the **P** key to change the data/parity bits selection.

R Key

In any SET-UP display, when the **SHIFT** key is down, press the **R** key to Recall the SET-UP features stored in user memory. User memory holds feature selections chosen from the terminal keyboard.

S Key

In any SET-UP display, when the **SHIFT** key is down, press the **S** key to store the SET-UP features in user memory. User memory holds feature selections chosen from the terminal keyboard.

T Key

In SET-UP A, when the **SHIFT** key is down, press the **T** key to select the tab default SET-UP feature selections. All tab stops are cleared and a tab stop is set every eighth character position.

Keyboard Indicators

Figure 1-10 shows the location of the keyboard indicators. The following paragraphs describe the function of each indicator.

ON LINE Indicator

The ON LINE indicator lights to show that the terminal is on-line and can communicate with the computer. The ON LINE or OFF LINE indicator shows that power is on.

OFF LINE Indicator

The OFF LINE indicator lights to show that the terminal is off-line and can not communicate with the computer. When the terminal is off-line, characters from the keyboard are displayed on the screen. The ON LINE or OFF LINE indicator show that the power is on.

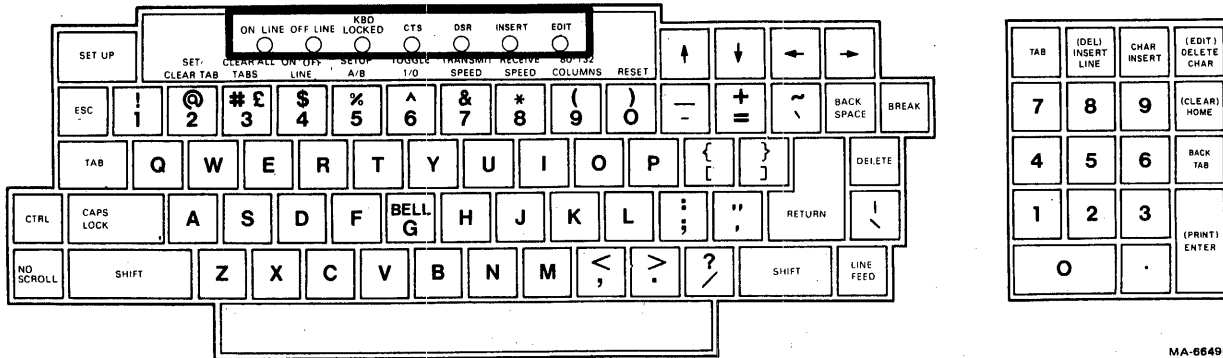

MA-6649B

Figure 1-10 VT131 Keyboard Indicators

KBD LOCKED Indicator

The KBD LOCKED indicator shows the keyboard locked condition. The keyboard locked condition shows when the keyboard character buffer can not accept characters from the keyboard. The keyboard character buffer holds character codes from the keyboard before they are transmitted to the computer as shown in Figure 1-1. While the KBD LOCKED indicator is on, characters from the keyboard are lost. If the keyclick SET-UP feature is on, keyclicks are not generated as keys are pressed.

NOTE: The terminal can receive characters from the computer during the keyboard locked condition.

The keyboard locked condition can be caused in several ways (Table 1-1). Therefore, depending on the cause of the condition several ways are available to clear the keyboard locked condition. When the keyboard locked condition is cleared, the KBD LOCKED indicator turns off and characters from the keyboard can be placed in the keyboard character buffer. These characters are taken from the buffer and transmitted to the computer. If the keyclick SET-UP feature is on, keyclicks are generated as keys are pressed.

CTS Indicator

The CTS indicator shows the on and off condition of the Clear To Send or Secondary Clear To Send modem connector signals. The internal communication switches of the VT131 terminal determine the connector signal used to turn on and off the CTS indicator. Refer to Chapter 7 for more information about the communication signals and internal communication switches used by the VT131 terminal.

NOTE: When the 20 mA current loop option (VT1XX-CA) is installed, the CTS signal is not used.

DSR Indicator

The DSR indicator shows the condition of the Data Set Ready modem connector signal. The on and off condition of the Data Set Ready signal turns on and off the DSR indicator. The Data Set Ready signal indicates that the local data set (connected to the terminal) is ready to transmit and receive characters. The off condition of the Data Set Ready signal indicates that all interface signals to the VT131 terminal should be ignored.

NOTE: When the 20 mA current loop option (VT1XX-CA) is installed, the DSR signal is not used.

INSERT Indicator

The INSERT indicator shows when the terminal is in insert or replace mode. Insert and replace modes are selected by the computer or the INSERT CHAR key in edit mode. When the terminal is in insert mode, the INSERT indicator is on and the terminal inserts characters at the cursor position. When characters are inserted, all previously displayed characters to the right of the cursor are moved to the right. Characters moved into the right margin are lost.

When the terminal is in replace mode, the INSERT keyboard indicator is off and characters are written over previously displayed characters at the cursor position.

EDIT Indicator

The EDIT indicator shows when the terminal is edit mode. When the indicator is on, characters typed on the keyboard are displayed on the screen. The characters are edited before being transmitted to the computer. When the EDIT indicator is off, the terminal transmits each character immediately when typed.

Table 1-1 Causes of the Keyboard Locked Condition

Cause	Method of Clearing Keyboard Locked
The terminal is not properly connected to the computer. The communication line signals are not correct for communication.	Cleared when a proper connection exists between the computer and terminal. Also, refer to the CTS and DSR indicators to determine if a proper connection exists.
When half duplex communication is selected (by the modem control SET-UP feature), the keyboard locked condition occurs whenever the terminal is receiving characters. The terminal can not transmit characters when receiving characters in half duplex.	Cleared when the line is turned around and the terminal can transmit characters.
Characters are being typed into the terminal faster than they can be transmitted.	Cleared when the characters in the keyboard character buffer are transmitted to the computer.
Characters are being transmitted in edit mode.	Cleared when the character transmission is completed or cancelled.
When a print operation is selected while off-line.	Cleared when the print operation is completed or cancelled.
The computer has intentionally turned off the keyboard.	The computer turns the keyboard on.

NOTE: Entering and exiting SET-UP with the KBD LOCKED indicator on erases the keyboard character buffer and cancels any print operation and any character transmission in edit mode.

Audible Indicators

There are three audible indicators used by the VT131 terminal; a keyclick, a bell tone, and a series of bell tones. The following paragraphs describe these indicators.

Keyclick

The terminal generates a keyclick when a key is pressed, with the following exceptions:

- SHIFT or CTRL keys do not generate any keyclick because these keys do not generate characters. They modify the character codes generated by other keys.
- KBD LOCKED indicator is on; in which case, the characters from the keyboard are lost.
- The keyclick SET-UP feature is off.

Bell Tone

The terminal generates a bell tone for each of the following conditions:

- A bell character was received from the computer.
- The cursor is eight characters away from the right margin and the margin SET-UP feature is on.
- An error is made when typing in edit mode.

Series of Bell Tones

The terminal generates a series of bell tones to indicate that the terminal can not store or recall SET-UP features in user memory. If the terminal can not use this memory, the terminal automatically uses the default SET-UP feature selections. Refer to Chapter 4 for more information about the SET-UP feature memories.

GENERAL

The VT131 terminal performs several print operations selected by either the terminal keyboard or computer. This chapter describes the print operations and keyboard selection procedures. Chapter 6 describes how the print operations are selected by the computer.

PRINT OPERATIONS

An optional serial printer is connected to the VT131 terminal printer interface as shown in Figure 2-1. The terminal uses the printer interface signals to determine if the serial printer is connected and ready to print. If the printer is unable to print and a print operation is selected, the terminal waits for the print operation to be completed. When the print operation is completed, the screen can display new characters.

Printing is performed using four print operations: auto print (line at a time), print screen, printer controller, and print cursor line. The computer or VT131 keyboard selects the print operations. All print operations can be selected by the computer while the VT131 terminal is on-line. Only the auto print and print screen operations can be selected by the VT131 terminal keyboard. The print operations selected by the keyboard are used when either on-line or off-line. If the VT131 terminal is off-line, the KBD LOCKED indicator is turned on until printing is complete.

Auto Print (Line at a Time)

The auto print operation prints the current line of characters on the screen as the cursor is moved off the line. The cursor moves to the next line when a line feed, form feed, vertical tab character is received. (This character is also transmitted to the printer at the end of the printed line.) If the auto wrap feature is on, characters received when the cursor is at the right margin are automatically wrapped to the next line. As the cursor leaves the line, the line is printed. The auto wrapped line ends with the carriage return and line feed characters.

Printing double height/double width characters results in printing the same line twice using single height/single width characters. Double width characters are printed as standard width characters.

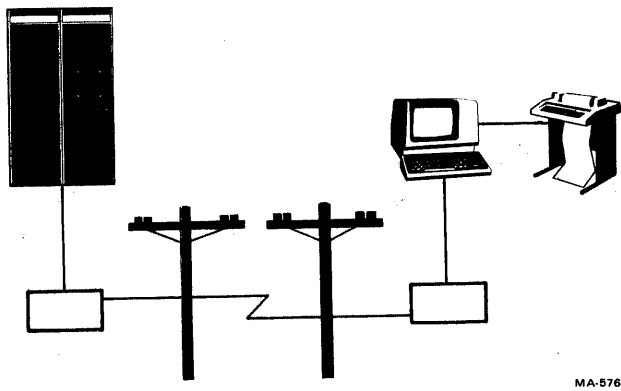

MA-5765

Figure 2-1 Local Printing Configuration

When selected auto print operation continues until turned off. Select auto print (line at a time) operation from the keyboard using the following procedure.

NOTE: Auto print does not operate when the terminal is in edit mode.

PROCEDURE	INDICATION/COMMENTS
1. Hold down the CTRL key and press the (PRINT) key and release both keys to turn on auto print.	No visual indication is provided, however, as the terminal receives line feeds, form feeds, vertical tabs and auto wrap lines the cursor moves to the next line. As the cursor moves to next line, the line is printed. To stop printing the line with the cursor, enter and exit SET-UP. The line is not printed, however auto print stays on. If printing is stopped by entering and exiting SET-UP, the printhead must be moved to the left margin.

Turn off auto print (line-at-a-time) operation from the keyboard using the following procedure.

PROCEDURE	INDICATION/COMMENTS
1. Hold down the CTRL key and press the (PRINT) key and release both keys to turn off auto print.	No visual indication is provided.

Print Screen

The print screen operation prints a copy of the screen. Depending on the print extent SET-UP feature selection, the scrolling region or complete screen is printed. The scrolling region is the area of the screen between the top and bottom margins. The top and bottom margins are selected by the computer.

Printing double height/double width characters results in printing the same line twice using single height/single width characters. Double width characters are printed as standard width characters.

Select print screen using the following procedure.

PROCEDURE	INDICATION/COMMENTS
1. Hold down the SHIFT key, press the (PRINT) key and release both keys to select print screen.	The characters displayed on the screen are printed.

To stop the print screen operation before printing is complete, enter and exit SET-UP. If printing is stopped by entering and exiting SET-UP, the printhead must be moved to the left margin.

Printer Controller

Printer controller is selected only by the computer to provide the computer with direct control of the printer. When printer controller is selected, characters received from the computer are printed and not displayed on the VT131 terminal screen.

NOTE: If print screen is selected from the VT131 keyboard while printer controller is selected, the screen is printed immediately.

Print Cursor Line

Print cursor line is selected only by the computer. Print cursor line prints the line of characters with the cursor. The cursor position on the screen is not changed.

Printing double height/double width characters results in printing the same line twice using single height/single width characters. Double width characters are printed as standard width characters.

NOTE: Print cursor line can be cancelled by entering and exiting SET-UP. If printing is stopped by entering and exiting VT131 terminal SET-UP, the printhead must be moved to the left margin.

GENERAL

The VT131 terminal can operate as an interactive or local editing terminal. This chapter defines the editing operations which can be performed locally from the keyboard. The chapter also explains how to transmit the edited information to the computer.

EDIT MODE

The VT131 terminal can operate as an interactive or editing terminal. When interactive mode is selected, keyboard entries are transmitted to the computer immediately and characters received from the computer are processed as received. The keys used when operating as an interactive terminal are described in Chapters 1 and 5.

When edit mode is selected, keyboard entries are not transmitted to the computer but are displayed on the screen for editing. Editing is the insertion or deletion of lines or characters on the screen from the keyboard before transmitting the characters to the computer. After the information is entered into the terminal and all corrections are performed, the terminal transmits the information as a block of characters to the computer.

SELECTING EDIT MODE

Edit mode is feature selected within the terminal. The edit mode feature can be selected in SET-UP. This feature can also be selected by the keyboard or computer when not in SET-UP. The SET-UP C display and the EDIT keyboard indicator always show the edit mode feature selection. When edit mode is selected from the keyboard the terminal can be either on-line or off-line. However, when operating while off-line the edited characters can be transmitted to the serial printer but not to the computer.

Select edit or interactive mode from the keyboard using the following procedure.

PROCEDURE	INDICATION/COMMENTS
1. Hold down the SHIFT key, press the EDIT key and release both keys.	When the EDIT keyboard indicator is on, the terminal is in edit mode. When the EDIT keyboard indicator is off, the terminal is in interactive mode.

EDITING OPERATIONS

The editing operations performed by the terminal are used to erase and insert characters and lines on the screen before transmission to the computer. These editing commands are performed at the cursor position within the margins (scrolling region). The scrolling region is defined by the screen margins which are selected by the computer. Scrolling is not permitted when a character or line feed is entered in the last position of the scrolling region.

Character Protection

The terminal can display several character attributes selected by the computer. The attributes of the terminal are: bold (increased intensity), underline, blink, reverse video (character background opposite the screen background SET-UP feature selection), normal (no character attribute) or any combination of character attributes. While in edit mode, character attributes can be used as protection attributes. Protection attributes are selected in SET-UP or by the computer to define protected and unprotected characters on the screen. Protected characters can not be overwritten, erased, moved or added to by the keyboard. Unprotected characters can be edited from the keyboard.

NOTE: Characters displayed in the margins are always protected characters.

A group of protected characters with the same character attribute are referred to as a field. The use of editing keys while in a protected field results as follows:

- ^ During normal typing, if the cursor would move into a protected field the cursor is moved to the next unprotected field.
- ^ Any attempt to enter a character into a protected field causes a bell tone and the cursor is moved to the next unprotected field, where the character is displayed. If there are no unprotected fields remaining on the screen the cursor is moved to the last character position of the screen and the character is discarded.

Moving the Cursor

All editing operations are performed at the cursor position. The cursor position can be selected without changing the characters displayed using the TAB, BACK TAB, (CLR)/HOME and cursor control keys. The use of the keys in edit mode is as follows:

TAB Key -- Press the TAB key (on either the main keyboard or auxiliary keypad) to advance the cursor to whichever of the following positions is found first:

- o the next protected field
- o the next tabulation stop setting (defined in SET-UP A)
- o the bottom margin (end of the scrolling region)

BACK TAB Key -- Press the **BACK TAB** key to move the cursor backward to whichever of the following positions is found first:

- o the start of the unprotected field with the cursor
- o the start of the previous unprotected field
- o the previous tabulation stop setting (defined in SET-UP A)
- o the top margin (begining of the scrolling region)

HOME Key -- Press the **HOME** key to move the cursor to the home position or origin. The home position is the first column, first line of the scrolling region.

Cursor Keys -- The cursor keys (<-, ->, ↑ and ↓) cause the cursor to move one character position in the direction indicated by the arrow on the keycap.

Inserting a line

While in edit mode, lines of characters can be added to the screen. The line of characters is added to the screen using the following procedure.

PROCEDURE	INDICATION/COMMENTS
1. Place the cursor where the line is to be added (Figure 3-1).	The line with the cursor can not have a protected field.
2. Press the INSERT LINE key (Figure 3-2).	The line with the cursor and all lines below the cursor are moved down one line. The line added to the screen has the same character attributes as the line moved down. The cursor is moved to the begining of the line. If a line on the screen would be moved onto a line with a protected field or into the bottom margin, the line moved is deleted. The deleted line is not transmitted to the computer.

Inserting a Character

While in edit mode, characters can be added to the screen. Characters are added to the screen using the following procedure.

PROCEDURE	INDICATION/COMMENTS
1. Place the cursor where the character is to be added (Figure 3-3).	The character position with the cursor can not be protected.

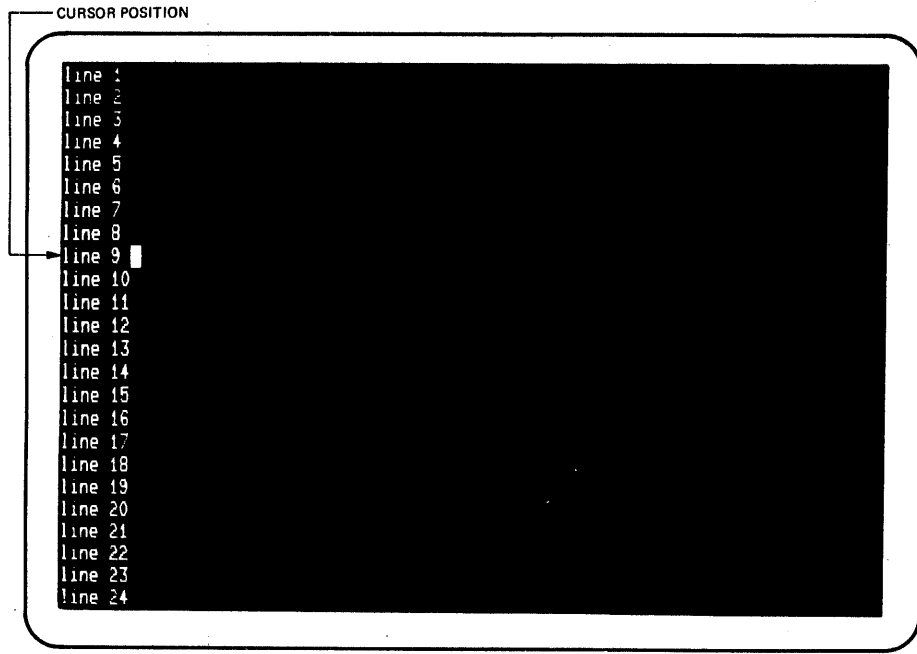

MA-3567

Figure 3-1 Cursor Positioned to Add a Line to the Screen

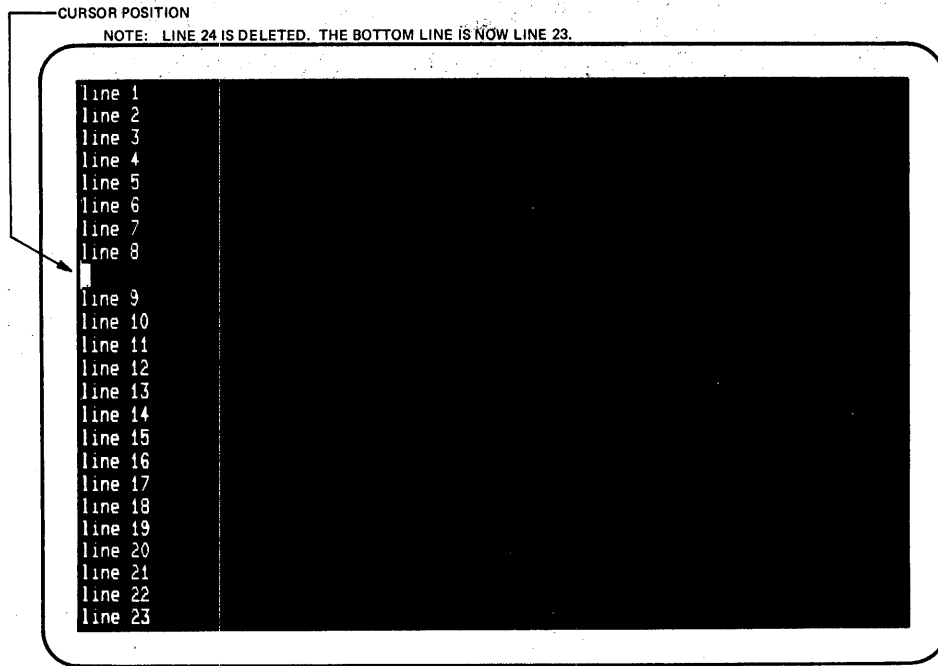
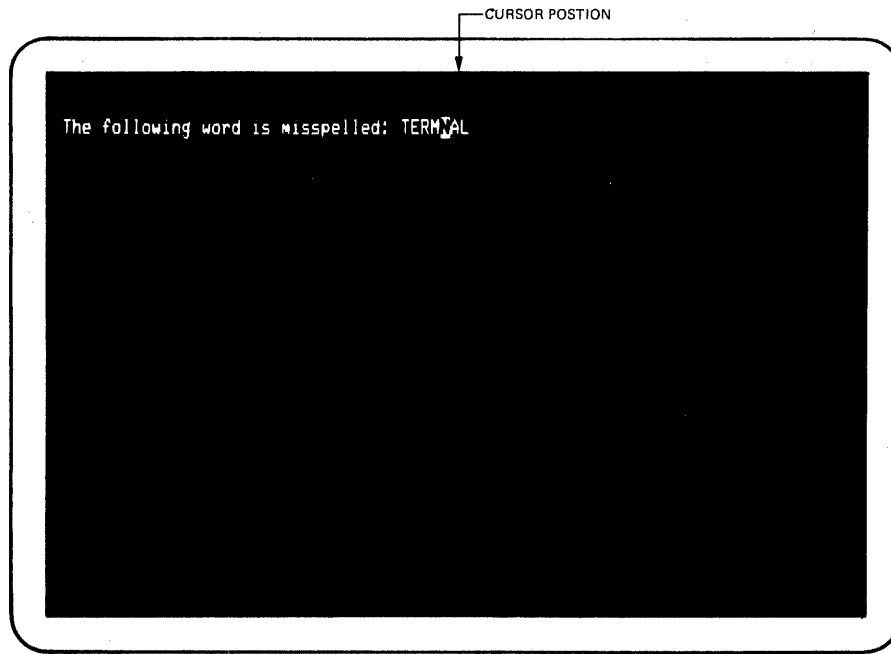

Figure 3-2 Line Added to the Screen



MA-3580

Figure 3-3 Positioning the Cursor to Insert a Character

2. Press the **CHAR INSERT** key. The **INSERT** keyboard indicator turns on to show that the terminal is ready to insert characters.
3. Type the character(s) to be inserted (Figure 3-4). All characters to the right of the cursor move to the right one character position for every character inserted. The cursor moves to the right one character position. If the cursor advances into a protected field, the cursor is automatically moved to the next unprotected field. If the characters moved to the right advance into a protected field or the right margin the characters are lost.
4. Press the **CHAR INSERT** key. The **INSERT** keyboard indicator turns off to show that the terminal is not inserting characters. Characters entered while the **INSERT** keyboard indicator off, replace the characters at the cursor position.

Deleting a Line

While in edit mode, characters can be deleted from the screen. A line of characters can be deleted from the screen using the following procedure.

PROCEDURE	INDICATION/COMMENTS
1. Place the cursor on the line to be deleted (Figure 3-5).	The line with the cursor can not have a protected field.
2. Press the DELETE LINE key (Figure 3-6).	The line on the screen is deleted and all lines below the deleted line move up one line. Lines with protected fields do not move when other lines on the screen are deleted. The line added to the bottom of the screen or at the next line with a protected field are filled with spaces. The line of spaces added to the screen have the same character attributes as the last line moved up. The cursor moves to the beginning of the line.

The **DELETE LINE** key has no effect on protected fields. If the **DELETE LINE** key is press while the cursor is in a protected field the cursor deletes the last character of the previous unprotected field.

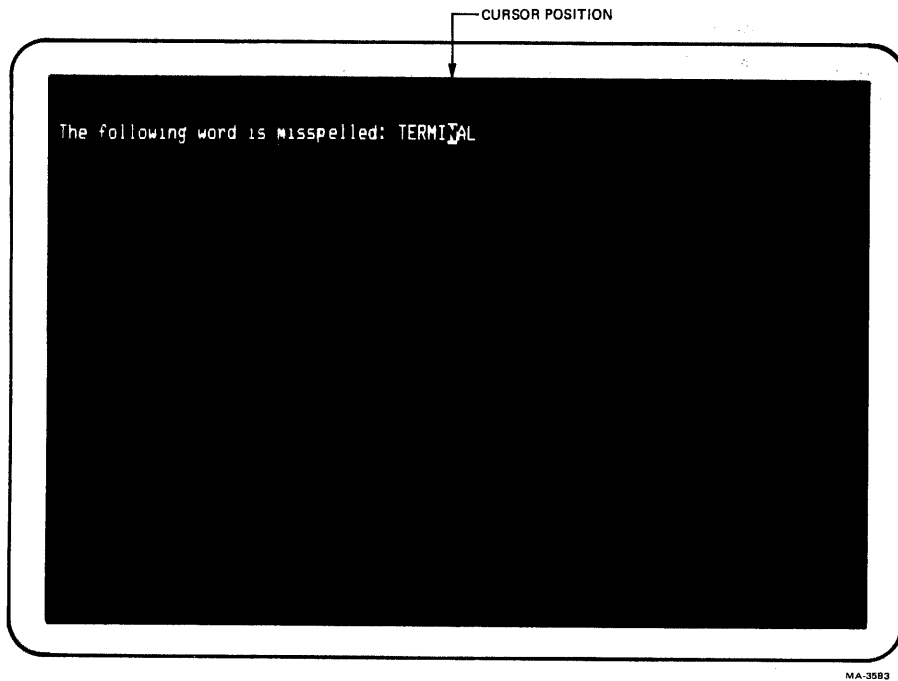

Figure 3-4 Character Inserted

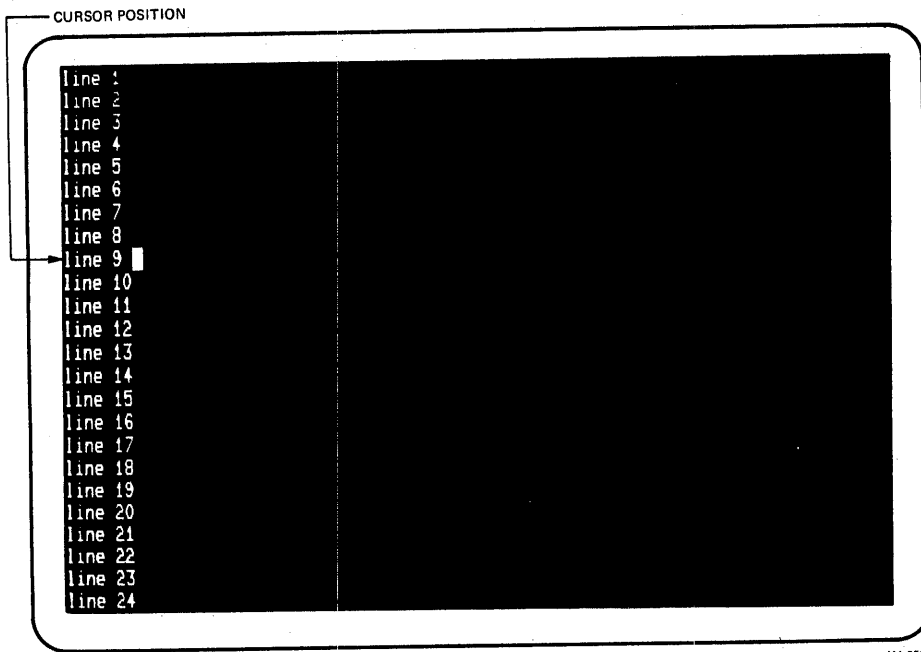

Figure 3-5 Cursor Positioned to Delete a Line from the Screen

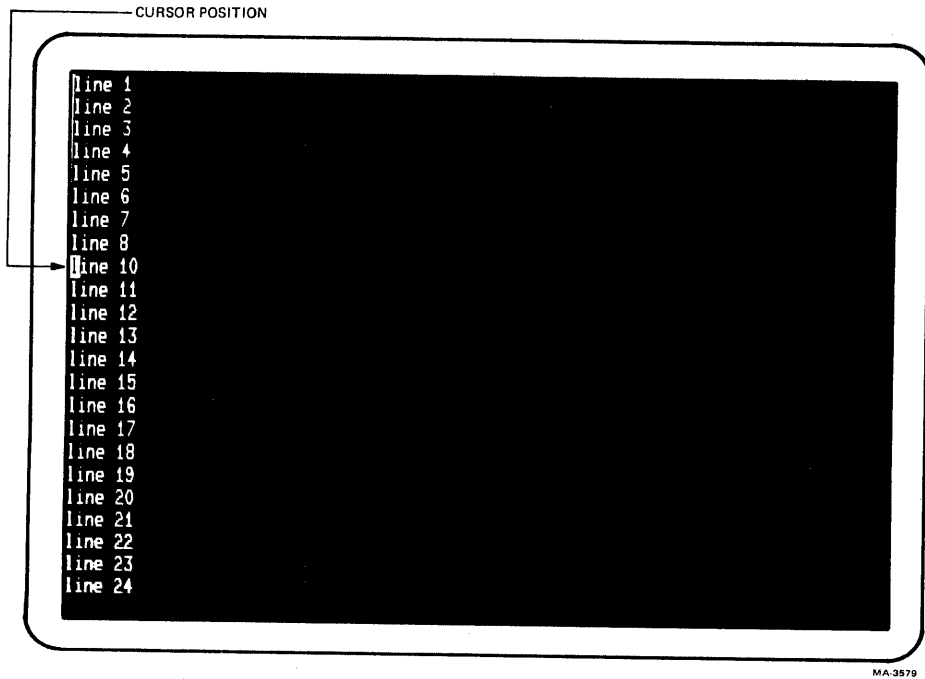

Figure 3-6 Line Deleted from the Screen

Deleting a Character

There are two keys used to delete characters from the screen in edit mode. The keys used are the DELETE CHAR key on the auxiliary keypad and the DELETE key on the main keyboard. Characters are deleted from the screen by the DELETE CHAR key using the following procedure.

PROCEDURE	INDICATION/COMMENTS
1. Place the cursor over the character to be deleted (Figure 3-7).	The cursor can not be over a protected character.
2. Press the DELETE CHAR key (Figure 3-8).	The character under the cursor is deleted from the screen. The cursor does not change position. All characters to the right of the cursor move one position to the left for each character deleted. A space character is added at the right end of the line or protected field. Characters in other protected fields or lines are not affected by the DELETE CHAR key.

The DELETE CHAR key has no effect on protected fields. If the DELETE CHAR key is press while the cursor is in a protected field, a bell tone is generated and the cursor moves to the next unprotected field. No characters are deleted.

Characters are deleted from the screen by the DELETE key on the main keyboard using the following procedure.

PROCEDURE	INDICATION/COMMENTS
1. Place the cursor over the character to the right of the character to be deleted (Figure 3-9).	
2. Press the DELETE key (Figure 3-10).	The character to the left of the cursor is deleted from the screen. The cursor and all characters to the right of the cursor in the field or line move to the left one position for each character deleted. A space character is added at the right end of the line or protected field containing the cursor. Characters in other fields or lines are not affected by the DELETE key.

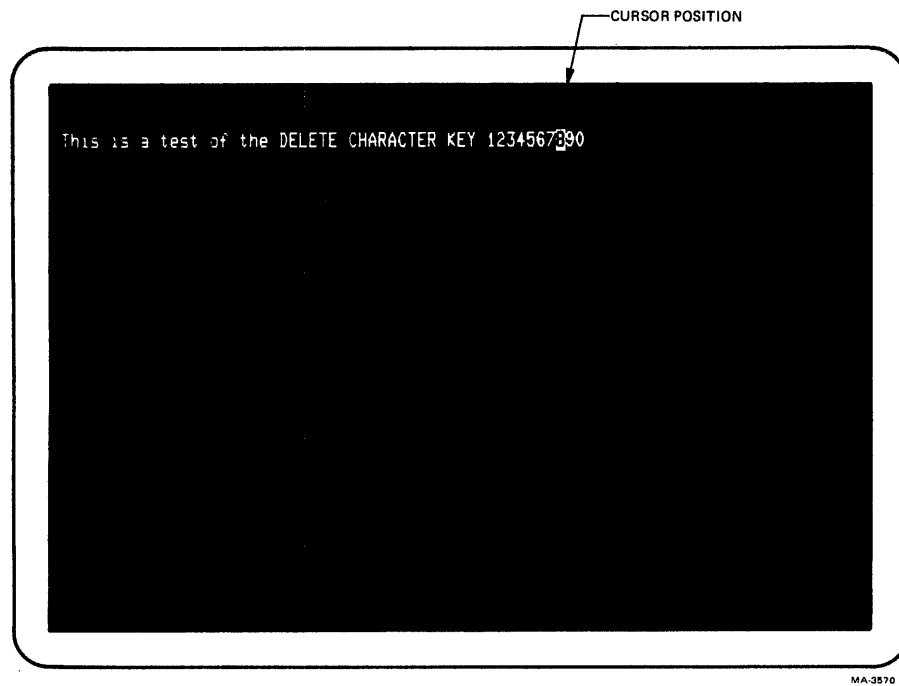
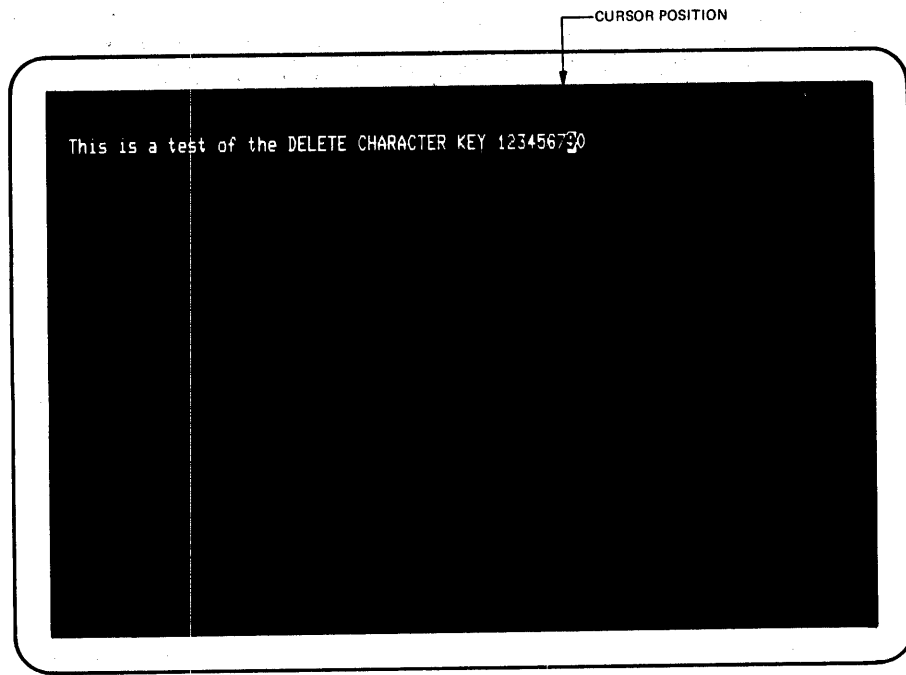

Figure 3-7 Positioning the Cursor to Delete a Character



MA-3578

Figure 3-8 Character Deleted

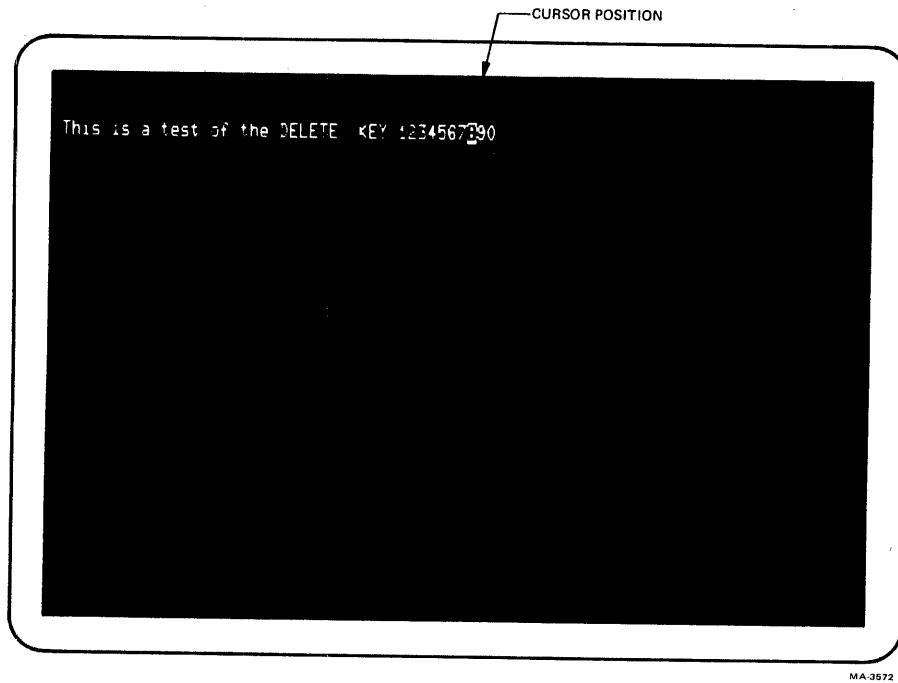

Figure 3-9 Positioning the Cursor to Correct a Typing Error

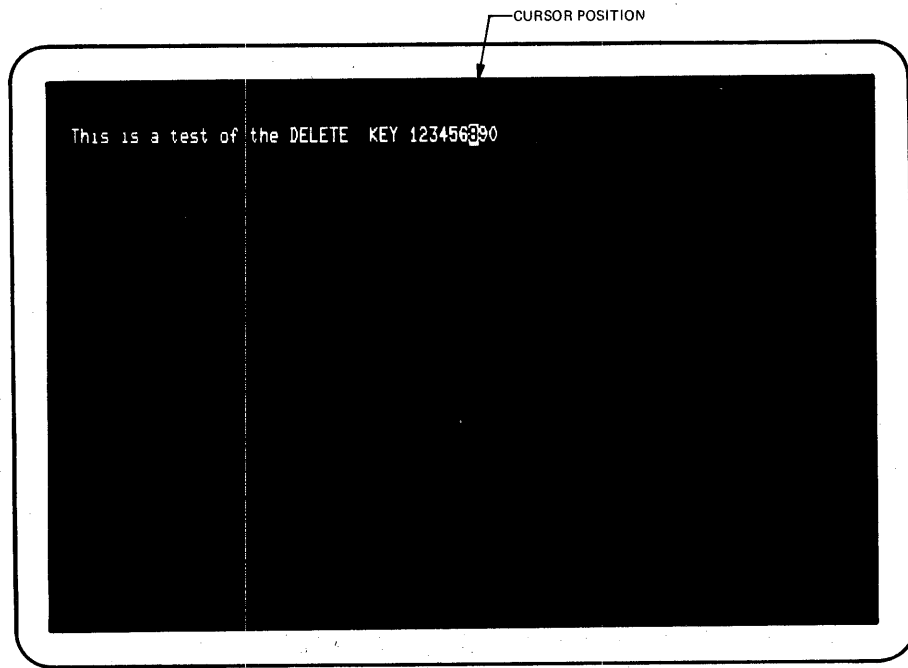

Figure 3-10 Error Corrected

If the **DELETE** key is pressed while in the first column of a line, the cursor is moved to the last column of the previous line deleting the character. If the **DELETE** key is pressed while the cursor is in a protected field the cursor deletes the last character of the previous unprotected field. The **DELETE** key has no effect when the cursor is in the first column of the first line in the scrolling region.

Clearing the Screen

The **(CLR)/HOME** key is used to erase all unprotected fields of the screen. To delete all unprotected fields of the screen perform the following procedure.

PROCEDURE	INDICATION/COMMENTS
1. With the SHIFT key down, press the (CLR) key and release both keys.	All unprotected fields on the screen are erased. The cursor moves to the first unprotected character position of the screen.

Transmitting Characters in Edit Mode

When editing is complete, the edited characters are transmitted to the computer as a block of characters. The terminal must be on-line when transmitting the block of characters to the computer. The transmission of characters is performed when requested from either the keyboard or computer. The size of the block of characters is determined by the Line Transmit and Transmit Termination **SET-UP** feature selections. The **ENTER** key causes the transmission of the block of characters to the computer. When the Line Transmit mode is selected, both the **ENTER** and **RETURN** key perform the same function. In line transmit mode, use the following procedure to transmit characters:

PROCEDURE	INDICATION/COMMENTS
1. In line transmit mode, press either the ENTER or RETURN key.	The KBD LOCKED indicator is turned on and the keyboard is locked until the transmission is complete. The cursor moves to either the first column of the current line or the first column of the next line, depending on the selection of the Line Feed/New Line SET-UP feature. If the cursor is at the bottom of the scrolling region, the cursor is moved to first column of the current line.

When transmitting a page or partial page (determined by the transmit termination mode feature selection) use the following procedure.

PROCEDURE

INDICATION/COMMENTS

1. Press the ENTER key to transmit the block of characters. The KBD LOCKED indicator is turned on and the keyboard is locked until the transmission is complete. The cursor does not change position

NOTE: The keyboard locked condition can be cleared by entering and exiting the SET-UP. This clears any pending transmit requests and cancels any transmissions that are in progress.

GENERAL

The VT131 terminal has many features that allow the terminal to be configured to meet specific applications. These features are selected while in SET-UP. This chapter describes SET-UP and each of the SET-UP features.

SET-UP

SET-UP is a special condition of the terminal that allows built-in features to be selected by the keyboard. When the terminal is in SET-UP, the current SET-UP feature selections are shown on the screen. Three SET-UP feature displays are used to show the features: SET-UP A, SET-UP B and SET-UP C as shown in Figure 4-1. The first display -- SET-UP A -- shows the location of the tab stops selected in the terminal and a visual ruler that numbers each column of the line. The second display -- SET-UP B -- shows the modem and printer interface feature selections and most of the other operating feature selections. The third display -- SET-UP C -- shows the editing feature selections.

SET-UP FEATURE SELECTION

The SET-UP features can be selected by either the keyboard or computer. When the features are selected by the keyboard, the terminal must be in SET-UP. SET-UP can be entered while either on-line or off-line. However, characters may be lost when entering SET-UP while on-line. Change the SET-UP feature selection from the keyboard using the following general procedure.

PROCEDURE	INDICATION/COMMENTS
1. Press the SET-UP key to enter SET-UP.	SET-UP A is displayed on the screen.
2. Press the SET-UP A/B/C key to select the correct SET-UP display.	The selected SET-UP display is on the screen.
3. Change the SET-UP feature selection.	The SET-UP display shows the feature selection.
4. If desired, Store the SET-UP features.	The terminal displays Wait and then SET-UP A.

SET-UP A

TO EXIT PRESS "SET-UP"

1234567890 1234567890 1234567890 1234567890 1234567890 1234567890 1234567890 1234567890

MA-9363

SET-UP B

TO EXIT PRESS "SET-UP"

V1.1

MODEM

PRINTER

P=7S T= 9600 R= 9600 FDX A

P=7S T/R= 300

1 1101 2 0111 3 0000 4 1101 5 1010 6 1000 7 0010

MA-9364

Figure 4-1 SET-UP Displays (Sheet 1 of 2)

SET-UP C
TO EXIT PRESS "SET-UP"

A 0140 B 0144 C 0000 D 0000

MA-3574

Figure 4-1 SET-UP Displays (Sheet 2 of 2)

5. Press the SET-UP key to exit SET-UP. Usually, characters displayed on the screen before entering SET-UP are not lost. These characters are displayed on the screen after exiting SET-UP.

NOTE: Entering SET-UP cancels print operations and edit mode character transmissions. If the KBD LOCKED indicator is on, the characters held in the keyboard buffer are erased before being transmitted to the computer and the indicator is turned off.

Some of the SET-UP features can also be selected by the computer. The SET-UP features that can be changed by the computer are listed in Table 4-1. Refer to Chapter 6 for more information about how the computer selects features.

SET-UP FEATURE MEMORIES

The SET-UP feature selections are held in the terminal's memory. The VT131 terminal has three SET-UP feature memories as shown in Figure 4-2. The SET-UP feature memories are: operating (temporary) memory, user memory and default memory.

Operating Memory

This memory holds the SET-UP feature selections that determine how the terminal operates. The SET-UP feature selections in the operating memory are shown by the SET-UP displays. Change the feature selections in this memory from the keyboard using the following procedure.

PROCEDURE	INDICATION/COMMENTS
1. Press the SET-UP key to enter SET-UP.	SET-UP A is displayed on the screen.
2. Press the SET-UP A/B/C key to select the correct SET-UP display.	The selected SET-UP display is on the screen.
3. Change the SET-UP feature selection.	The SET-UP display shows the feature selection.
4. Press the SET-UP key to exit SET-UP.	The terminal operates according to the new SET-UP feature selections in operating memory.

User Memory

This memory holds SET-UP feature selections that replace the operating memory features when a recall or reset is performed. Also, the user memory features replace the operating memory features when the terminal is powered up (turned on). Turning off the power does not affect the SET-UP features in user memory.

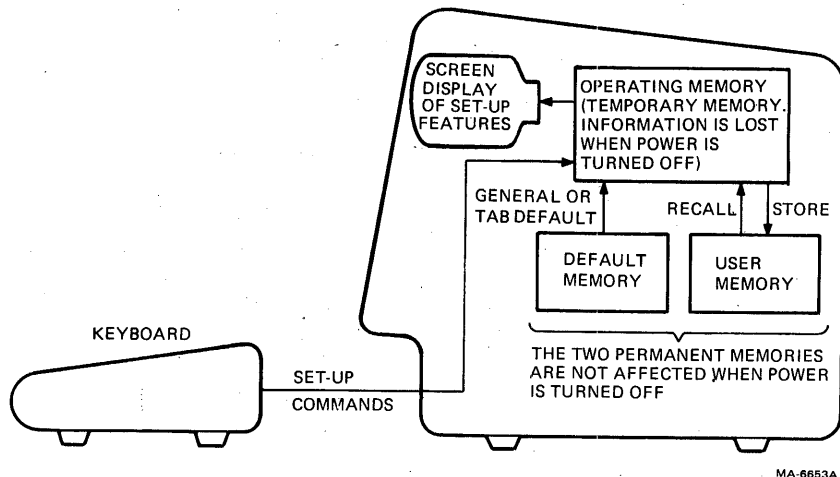

Figure 4-2 SET-UP Feature Memories

The features in this memory are stored by the keyboard in SET-UP. The computer can not change the SET-UP feature selections in this memory. SET-UP features are moved between the operating memory and the user memory using a store, recall and reset. Descriptions of store, recall and reset are provided in the following paragraphs. The procedures used to store, recall and reset are also described.

Store - This enters the operating memory SET-UP feature selections into user memory. Storing is performed from the terminal keyboard. The computer can not store SET-UP features in the user memory. Store the SET-UP feature selections in the user memory using the following procedure.

NOTE: The modem interface is not monitored during a store, therefore received characters may be lost.

PROCEDURE	INDICATION/COMMENTS
1. Press the SET-UP key to enter SET-UP.	SET-UP A is displayed on the screen.
2. Hold down the SHIFT key, press the S key and release both keys.	The terminal displays Wait while entering the feature selections into user memory. When the features are stored, SET-UP A is displayed on the screen.
3. Press the SET-UP key to exit SET-UP.	

Recall - This enters the user memory SET-UP feature selections into the operating memory. All features previously in operating memory are erased. Recall the SET-UP features from user memory into operating memory using the following procedure.

PROCEDURE	INDICATION/COMMENTS
1. Press the SET-UP key to enter SET-UP.	SET-UP A is displayed on the screen.
2. Hold down the SHIFT key, press the R key and release both keys.	The terminal erases the screen and displays Wait while recalling the feature selections from user memory. When the features are recalled: * the terminal disconnects from the communication line. * the input and keyboard character buffers are erased. * SET-UP A is displayed on the screen.
3. Press the SET-UP key to exit SET-UP.	The characters displayed on the screen before entering SET-UP are lost. When exiting SET-UP the screen is blank.

Table 4-1 SET-UP Features That Can Be Changed By The Computer

SET-UP Feature	Can be changed by Computer
ON/OFF LINE	
Screen Brightness	
Columns Per Line	X
Tab Stops	X
Scroll	X
Auto Repeat	X
Screen Background	X
Cursor	
Margin Bell	
Keyclick	
ANSI/VT52	X
Auto XON/XOFF	
US/UK Character Set	X
Auto Wrap	X
Line Feed/New Line	X
Local Echo	X
Print Termination	X
Print Extent	X
1 or 2 Stop Bits	
Receive Parity	
Break Enable	
Disconnect Char Enable	
Disconnect Delay	
Auto Answerback Enable	
Initial Direction	
Auto Turnaround	
WPS Terminal	
Power	
Clock	
Modem Data/Parity Bits	
Transmit Speed	
Receive Speed	
Modem Control	
Turnaround(End of Block)/	
Disconnect Character	X
Answerback	
Printer Data/Parity Bits	
Transmit/Receive Speed	
Edit mode	X
Edit Key	X

Table 4-1 SET-UP Features That Can Be Changed By The Computer (Cont)

SET-UP Feature	Can be changed by Computer
Guarded Area Transfer	X
Space Compression	X
Line Transmit	X
Transmit Termination	X
Transmit Execution	X
Bold Protect	X
Underline Protect	X
Blink Protect	X
Reverse Video Protect	X
Normal Protect	X
Erasure Mode	X
End of Line Char Enable	
End of Line Character	

Reset - This causes the terminal to perform a self-test and recall the user memory SET-UP feature selections to the operating memory. All features previously in operating memory are erased. Reset the terminal using the following procedure.

PROCEDURE	INDICATION/COMMENTS
1. Press the SET-UP key to enter SET-UP.	SET-UP A is displayed on the screen.
2. Press the RESET key.	<p>When a reset is performed:</p> <ul style="list-style-type: none"> * the terminal disconnects from the communication line. * the power up self-test is run * a recall is performed and the terminal operates according to the SET-UP feature selections in user memory. * the input and keyboard character buffers are erased. * the characters displayed on the screen before entering SET-UP are lost and the screen is blank. * the terminal automatically exits SET-UP.

Default Memory

This memory holds default SET-UP feature selections for all the SET-UP features. The default SET-UP feature selections are typical feature selections used by the terminal. The feature selections in the default memory can not be changed by the user. When a default occurs, the operating memory SET-UP feature selections change to the default selections. There are two types of default selections, a general default and a tab default. The SET-UP features in user memory are not changed by a default. A default occurs when:

- ^ The terminal can not read the user memory
- ^ A default is selected from the keyboard

General Default - This changes all of the SET-UP features in operating memory to the selections in the default memory. SET-UP A features are set to 80 columns per line with a tab stop every eighth column. SET-UP B and SET-UP C default features are shown in Figure 4-3. The terminal is off-line and the answerback message is erased from operating memory. The features in the user memory are not changed. Select a general default from the keyboard using the following procedure.

PROCEDURE	INDICATION/COMMENTS
1. Press the SET-UP key to enter SET-UP.	SET-UP A is displayed on the screen.
2. Hold down the SHIFT key, press the D key and release both keys.	When a default is selected: * the terminal disconnects from the communication line. * the screen is erased. * the terminal operates according to the SET-UP feature selections in default memory. * the input and keyboard character buffers are erased. * the characters displayed on the screen before entering SET-UP are lost and the screen is blank. * SET-UP A is displayed.
3. Press the SET-UP key to exit SET-UP.	The characters displayed on the screen before entering SET-UP are lost. When exiting SET-UP the screen is blank.

SET-UP B

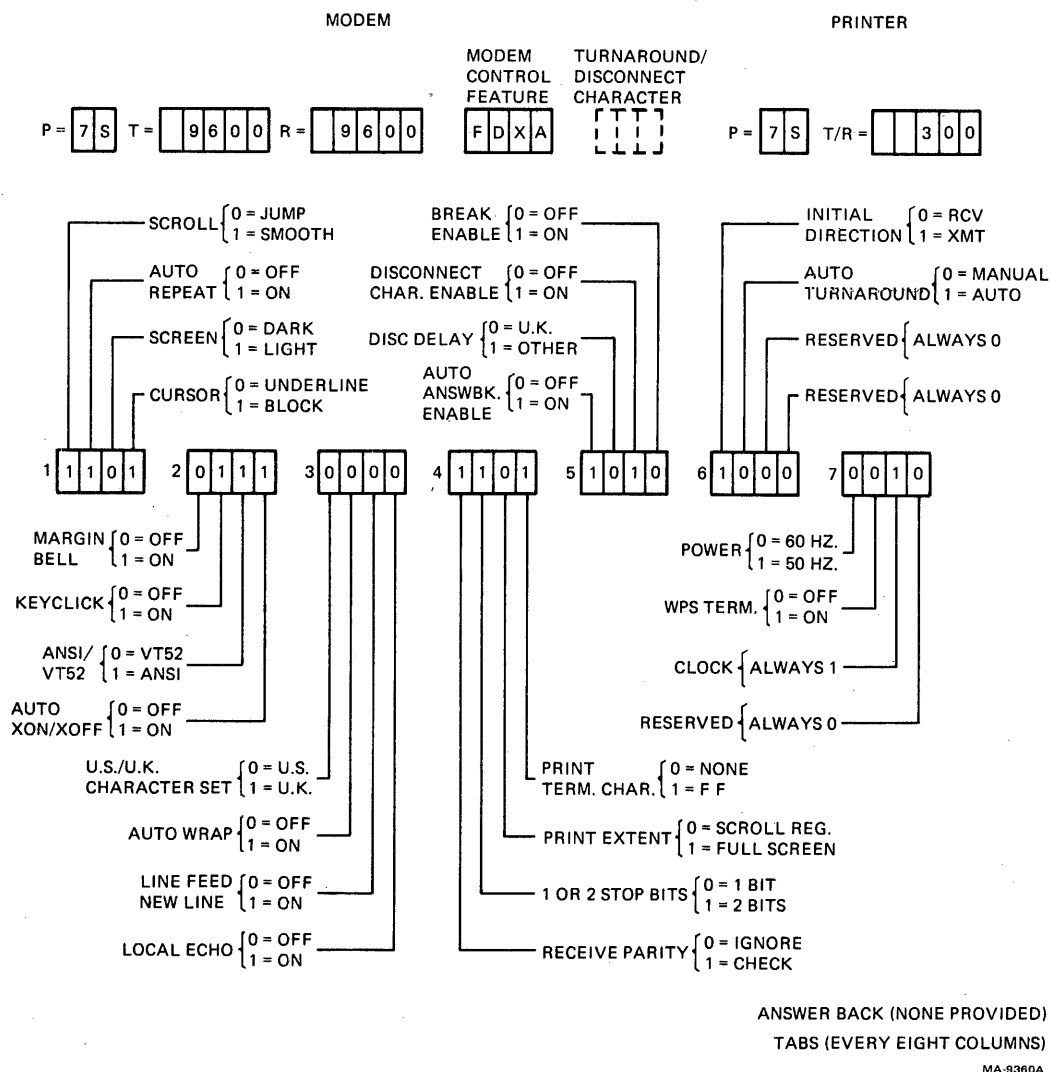

Figure 4-3 Default Feature Selections (Sheet 1 of 2)

SET-UP C

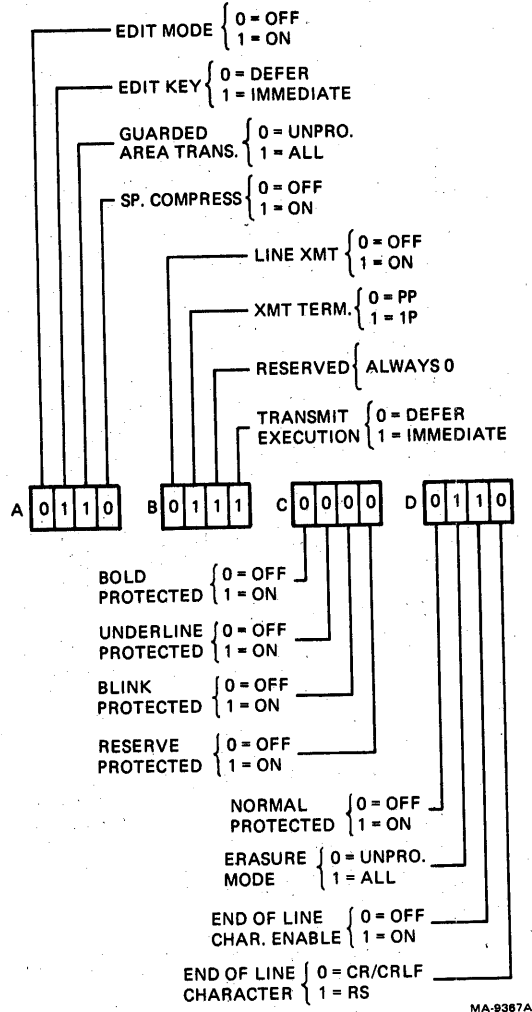

Figure 4-3 Default Feature Selections (Sheet 2 of 2)

Tab Default - This clears all terminal tab stop settings and sets a new tab stop at every eighth column position. Select a tab default from the keyboard using the following procedure.

PROCEDURE	INDICATION/COMMENTS
1. Press the SET-UP key to enter SET-UP.	SET-UP A is displayed on the screen.
2. Hold down the SHIFT key, press the T key and release both keys.	The tab stops are set every eighth character position in SET-UP A.
3. Press the SET-UP key to exit SET-UP.	The characters displayed on the screen when entering SET-UP are again displayed on the screen.

SET-UP FEATURE TYPES

SET-UP features are features selected to change how the VT131 terminal operates. These features are provided so that the terminal can be configured to meet operator preferences, provide compatibility to the computer and the ac power source. Table 4-2 divides the SET-UP features into four general types: operator preference, communication compatibility, editing and installation.

Operator Preference Features

These features configure the terminal to meet operator preferences. These features do not affect the information transferred between the terminal, computer and printer.

Communication Compatibility Features

These features configure the terminal to be compatible with a computer and optional serial printer. There are many combinations of SET-UP features used when communicating with a computer or printer. These features are selected to allow the terminal to communicate with the computer. An error in these feature selections may stop communication or cause incorrect information to be transferred between the terminal, computer and printer.

NOTE: The SET-UP features used to provide compatibility to the computer and serial printer are described in this chapter. However more information about the use of these SET-UP features is provided in Chapter 7.

Editing Features

These features configure the terminal to operate as an editing terminal. The features determine how the terminal performs editing operations. Like the communication features, these features are selected to allow the terminal to communicate with the computer. An error in these feature selections may stop communication or cause incorrect information to be transferred between the terminal and computer.

Table 4-2 SET-UP Feature Types

SET-UP Feature	Operator Preference	Communication Compatibility	Installation	Editing
ON/OFF LINE		X		
Screen Brightness	X			
Columns Per Line		X		
Tab Stops		X		
Scroll		X		
Auto Repeat	X			
Screen Background	X			
Cursor	X			
Margin Bell	X			
Keyclick	X			
ANSI/VT52		X		
Auto XON/XOFF		X		
US/UK Character Set		X		
Auto Wrap		X		
Line Feed/New Line		X		
Local Echo		X		
Print Term Char				
Print Extent				
1 or 2 Stop Bits		X		
Receive Parity		X		
Break Enable		X		
Disconnect Char				
Enable		X		
Disc Delay		X		
Auto Answerback				
Enable		X		
Initial Direction		X		
Auto Turnaround		X		
Reserved				
Reserved				
Power			X	
WPS Terminal			X	
Clock			X	
Reserved				
Modem Data/				
Parity Bits		X		
Transmit Speed		X		
Receive Speed		X		
Modem Control		X		
Turnaround(End of Block)/				
Disconnect Char		X		X

Table 4-2 SET-UP Feature Types (Cont)

SET-UP Feature	Operator Preference	Communication Compatibility	Installation	Editing
Answerback		X		
Printer Data/ Parity Bits		X		
Transmit/Receive Speed		X		
Edit mode				X
Edit Key				X
Guarded Area Transfer				X
Space Compression				X
Line Transmit				X
Transmit Termination				X
Transmit Execution				X
Bold Protect				X
Underline Protect				X
Blink Protect				X
Reverse Video Protect				X
Normal Protect				X
Erasure Mode				X
End of Line Char Enable				X
End of Line Character				X

Installation Features

These features configure the terminal for operation in different installations. If the location of the terminal is changed, verify these feature selections.

SET-UP FEATURES DESCRIPTIONS

The SET-UP feature descriptions are arranged by the SET-UP display in which they are shown. There are four types: general SET-UP features (features changed in any SET-UP display), SET-UP A features, SET-UP B features and SET-UP C features.

A general procedure for changing each SET-UP feature in the SET-UP display is provided at the beginning of each SET-UP display section. For features needing a more detailed procedure, the procedure is provided with the SET-UP feature description.

General SET-UP Features

The on/off line and screen brightness SET-UP features may be changed in any SET-UP display. Dedicated keys are used to select these features. Therefore, each feature description includes the specific procedure used to select the feature.

ON/OFF LINE

The on/off line feature places the terminal either on-line or off-line as shown in Figure 4-4. While on-line, the keyboard ON LINE indicator is on and the terminal can communicate with the computer. Therefore, keyboard entries are transmitted to the computer and characters received from the computer are displayed on the screen.

While off-line, the keyboard OFF LINE indicator is on and the terminal can not communicate with the computer. Keyboard entries are not transmitted but are displayed on the screen. Select on-line or off-line using the following procedure.

NOTE: When the disconnect character enable SET-UP feature is on, a long break disconnect should be performed before the terminal is switched off-line. Refer to Chapter 7 for more information about the use of the long break disconnect.

PROCEDURE	INDICATION/COMMENTS
1. Press the SET-UP key to enter SET-UP.	SET-UP A is displayed on the screen.
2. Press the OFF/ON LINE key to select on-line or off-line.	The ON LINE and OFF LINE keyboard indicators show the feature selection.
3. Press the SET-UP key to exit SET-UP.	The characters displayed on the screen when entering SET-UP are displayed.

Screen Brightness

The screen brightness feature adjusts the brightness of the terminal screen. The ↑(up arrow) key increases the screen brightness; the ↓(down arrow) key decreases the screen brightness. Select screen brightness using the following procedure.

PROCEDURE	INDICATION/COMMENTS
1. Press the SET-UP key to enter SET-UP.	SET-UP A is displayed on the screen.
2. Press the ↑(up arrow) or ↓(down arrow) key to select brightness.	The display brightness is selected.
3. Press the SET-UP key to exit SET-UP.	The characters displayed on the screen when entering SET-UP are displayed.

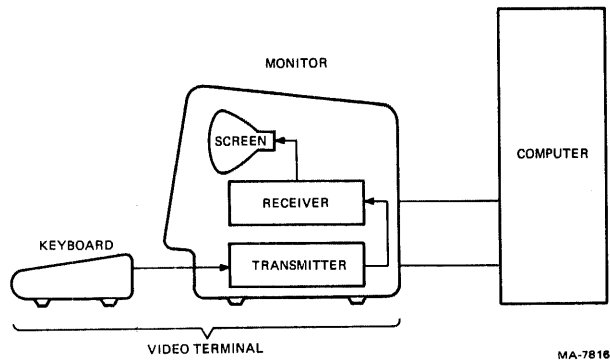
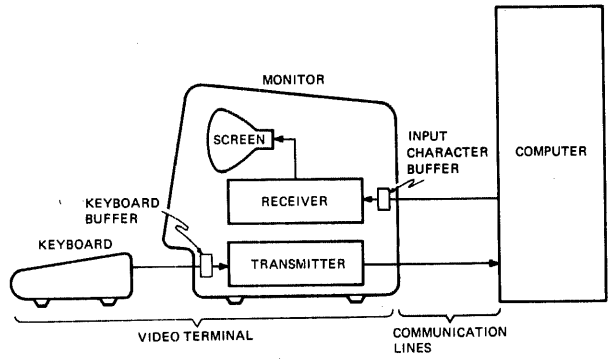

MA-7816

Figure 4-4 ON/OFF Line General Block Diagram

SET-UP A Features

While in SET-UP A, the display is similar to Figure 4-5. The SET-UP A display summarizes the number of columns per line and the tab stop feature selections. The bottom line of the display is a "ruler" which numbers each column position on a line. The location of each tab stop is shown by a "T" displayed above the ruler. The SET-UP A features are selected using dedicated keys. Therefore, each feature description includes the specific procedure used to select the feature. The following paragraphs describe the SET-UP A features.

Columns Per Line

The columns per line feature selects a display of either 80 or 132 columns per line. The screen uses 24 display lines regardless of the columns per line selection. The displayed lines with 132 columns per line selected are the same width on the screen as the 80 columns per line selection, but the columns are closer together as shown in Figure 4-6. When changing between the 80 and 132 columns per line, the characters displayed on the screen when entering SET-UP are erased. Select the number of columns per line using the following procedure.

NOTE: When printing characters displayed on the screen, the horizontal margins of the printer must be set as wide or wider than the number of columns per line selected by this feature.

PROCEDURE	INDICATION/COMMENTS
1. Press the SET-UP key to enter SET-UP.	SET-UP A is displayed on the screen.
2. Press the 80/132 COLUMNS key to select the number of columns per line.	The bottom line of the display is a "ruler" which numbers each column position on a line. This ruler indicates the feature selection.
3. Press the SET-UP key to exit SET-UP,	The characters displayed on the screen before entering SET-UP are lost. When exiting SET-UP the screen is blank.
or	
press the SETUP A/B/C key to enter SET-UP B.	SET-UP B is displayed on the screen.

Tab Stops

Tab stops are column positions selected on lines of the terminal screen. The cursor can tab (advance) to the column with the tab stop. The tab stops may be changed one at a time, or all tabs stops can be cleared and then set one tab stop at a time.

The SET/CLEAR TAB key sets and clears each tab stop, one at a time. The CLEAR ALL TABS key clears all tab stops. A tab default is provided to set a tab stop every 8th column position. (refer to the SET-UP Feature Memories section of this chapter for more information about tab default.) Select the tab stops using the following procedure.

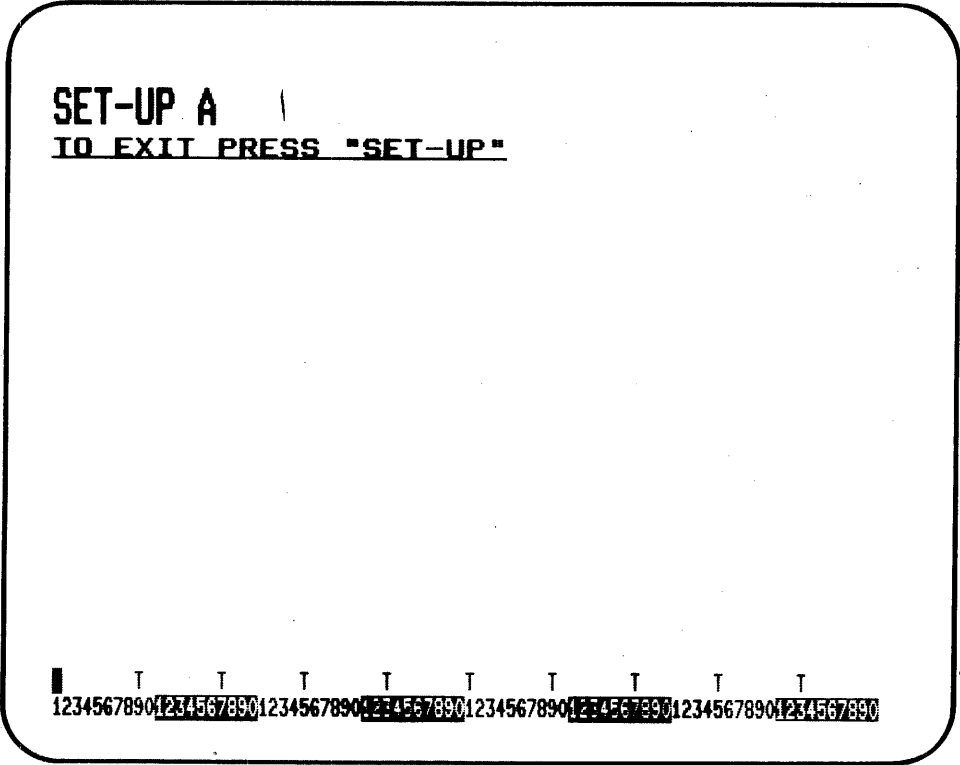

MA-9363

Figure 4-5 SET-UP A Display

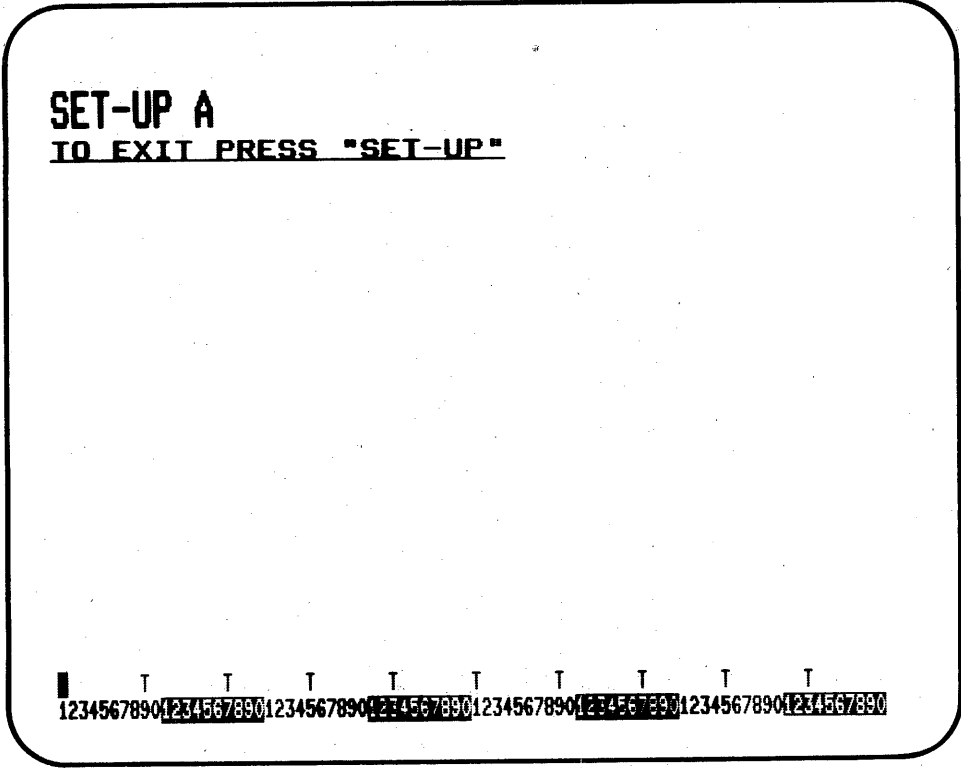

MA-9363

Figure 4-6 80 and 132 Columns Per Line (Sheet 1 of 2)

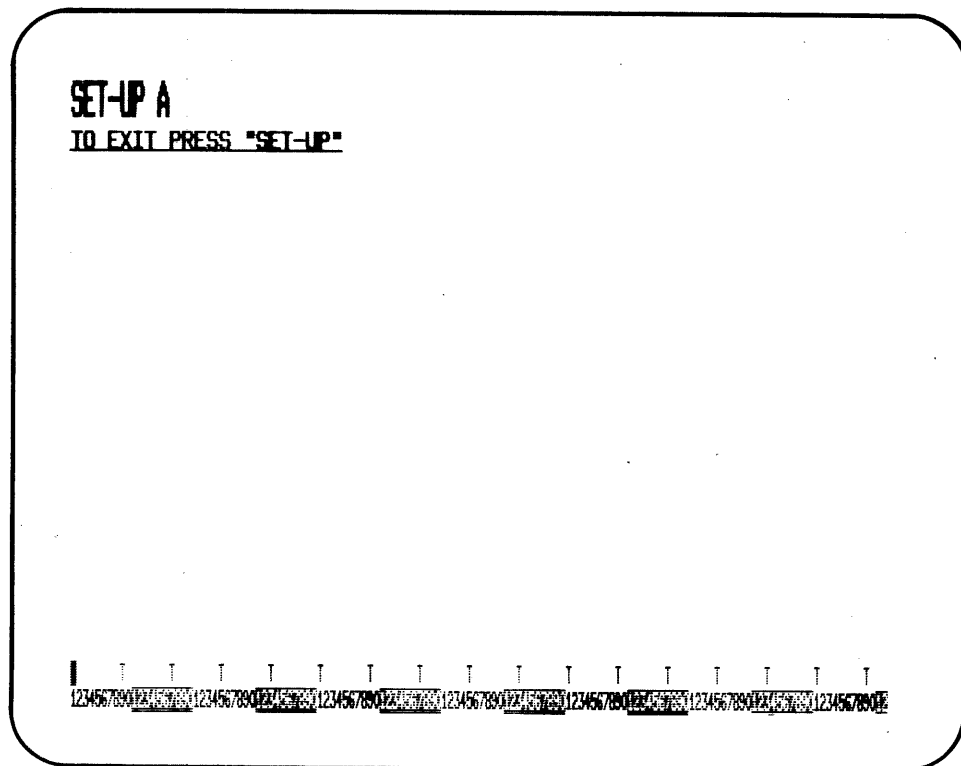

MA-9365

Figure 4-6 80 and 132 Columns Per Line (Sheet 2 of 2)

NOTE: When printing characters displayed on the screen, the terminal and printer horizontal tab stops are ignored. However, when using printer controller operation the printer tab stops must be selected to match the computer.

PROCEDURE	INDICATION/COMMENTS
1. Press the SET-UP key to enter SET-UP.	SET-UP A is displayed on the screen.
2. Press the CLEAR ALL TABS key or the SET/CLEAR TABS key	All tabs are cleared. The tab is set or cleared at the cursor position. The cursor is moved using the <(left arrow), >(right arrow), RETURN, TAB and SPACE BAR keys.
3. Press the SET-UP key to exit SET-UP,	The characters displayed on the screen before entering SET-UP are displayed.
or	
press the SETUP A/B/C key to enter SET-UP B.	SET-UP B is displayed on the screen.

SET-UP B Features

SET-UP B can only be entered from SET-UP A. The SET-UP B display is similar to Figure 4-7. Figure 4-8 summarizes the SET-UP B display features. The bottom line of the display shows groups of switches indicating the features selected. Above the switches modem interface and printer interface features are shown.

The modem and printer interface features are selected using dedicated keys. Therefore, the procedure to select these features is provided with the feature descriptions. All other SET-UP B features are selected using the SET-UP switches. Change SET-UP feature switch selections using the following procedure.

PROCEDURE	INDICATION/COMMENTS
1. Press the SET-UP key to enter SET-UP.	SET-UP A is displayed on the screen.
2. Press the SET-UP A/B/C key to enter SETUP B.	SET-UP B is displayed on the screen.
3. Position the cursor over the SET-UP feature switch to be changed.	The cursor is positioned using the <(left arrow), >(right arrow), RETURN, TAB and SPACE BAR keys.

SET-UP B

TO EXIT PRESS "SET-UP"

VI.1 -

MODEM

PRINTER

P=7S T= 9600 R= 9600 FDX A

P=7S T/R= 300

1 1101 2 0111 3 0000 4 1101 5 1010 6 1000 7 0010

MA-9364

Figure 4-7 SET-UP B Display

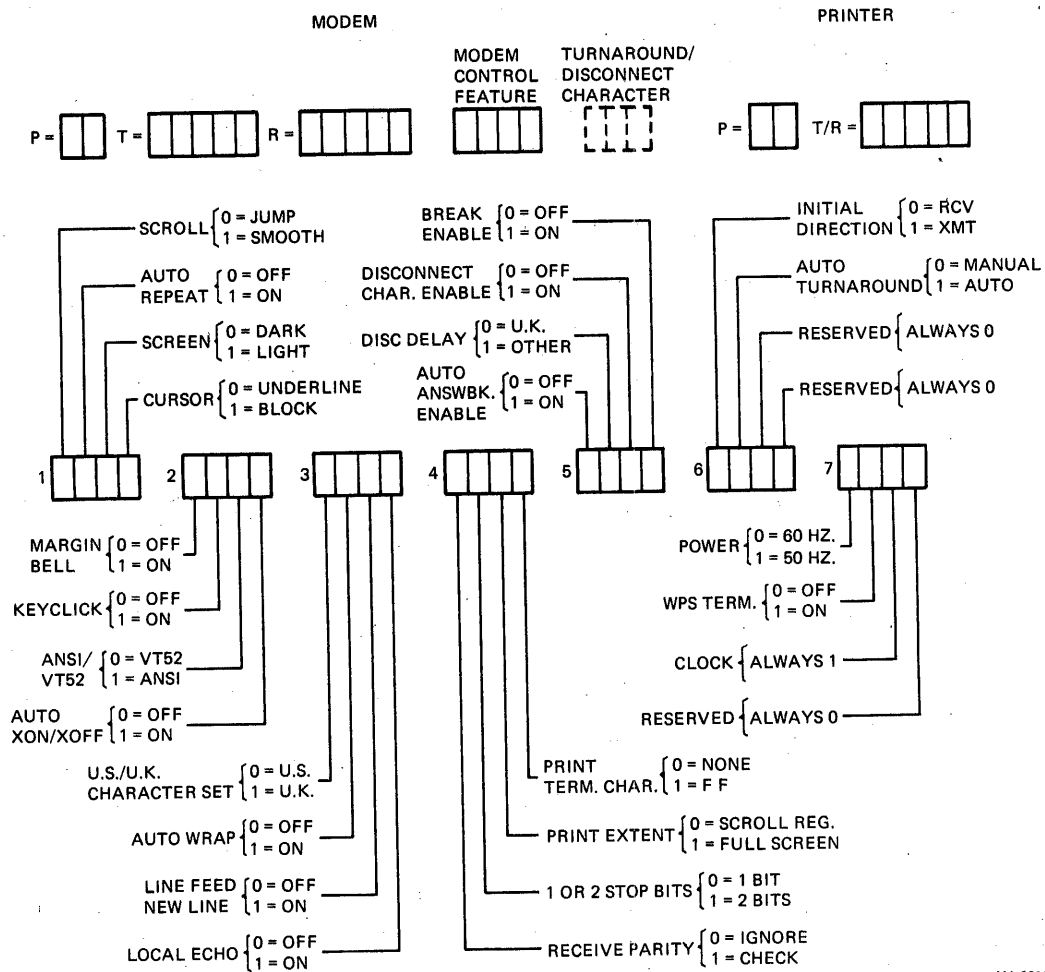

MA-9360

Figure 4-8 SET-UP B Summary

4. Use the **TOGGLE 1/0** key to select the feature. The screen displays the feature selection.
5. Press the **SET-UP** key to exit SET-UP, The characters displayed on the screen before entering SET-UP are displayed.

or

press the **SETUP A/B/C** key to enter SET-UP C. SET-UP C is displayed on the screen.

The following paragraphs describe the features in the order of the switches on the screen. The switches are referred to within this chapter by the group and the number of the switch within the group. (Example: switch 3-2 is the third group of switches - second switch counting from left to right.) Following these features the MODEM and PRINTER interface parameters are listed with a detail selection procedure. The answerback feature is listed at the end of the feature descriptions.

Scroll Switch 1-1: 0 = Jump, 1 = Smooth
Scrolling is the upward or downward movement of existing lines on the screen. Scrolling is performed to make room for new lines at the bottom or top of the screen. It can be performed in two ways: jump scroll or smooth scroll.

With jump scroll selected, new lines are displayed on the screen as fast as they are received. When using half duplex communication or full duplex communication without XON/XOFF support, jump scroll is recommended.

With smooth scroll selected, the speed at which new lines can be displayed is limited. Therefore, the movement of lines occurs at a smooth steady rate. The lines displayed on the screen can usually be read easier. Smooth scroll allows a maximum of six lines per second to be added to the screen.

Auto Repeat Switch 1-2: 0 = Off, 1 = On
The auto repeat feature causes a key to be automatically repeated at the rate of about 30 characters per second, when the key is held down for more than one half second. The auto repeat feature affects all keyboard keys except the following: SET-UP, ESC, RETURN, ENTER, NO SCROLL, CTRL and any key. When this feature is turned off, the keys do not automatically repeat.

Screen Background Switch 1-3: 0 = Dark, 1 = Light
The screen background feature determines the type of screen background as shown in Figure 4-9. With dark background selected, the display has light characters on a dark background. With light background (reverse screen) selected, the display has dark characters on a light background.

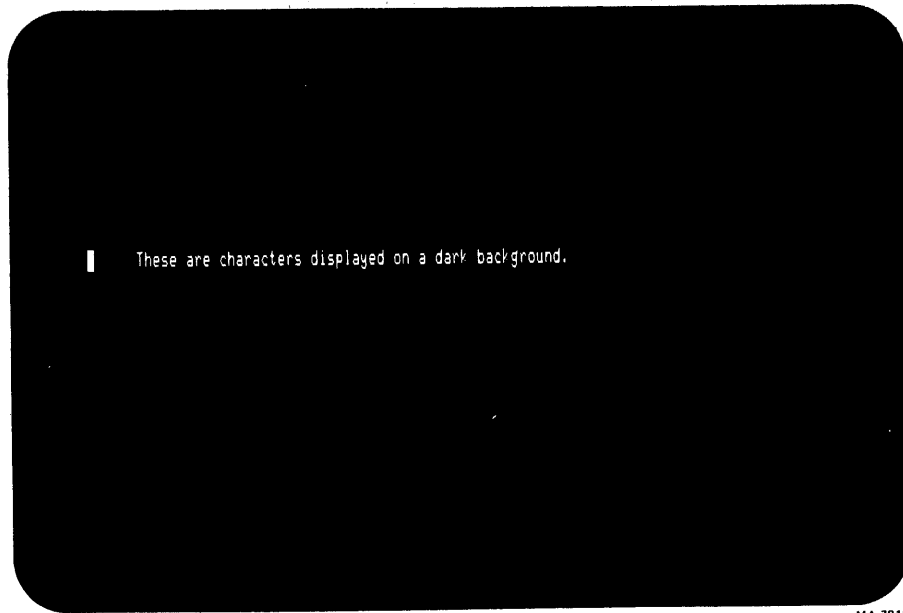
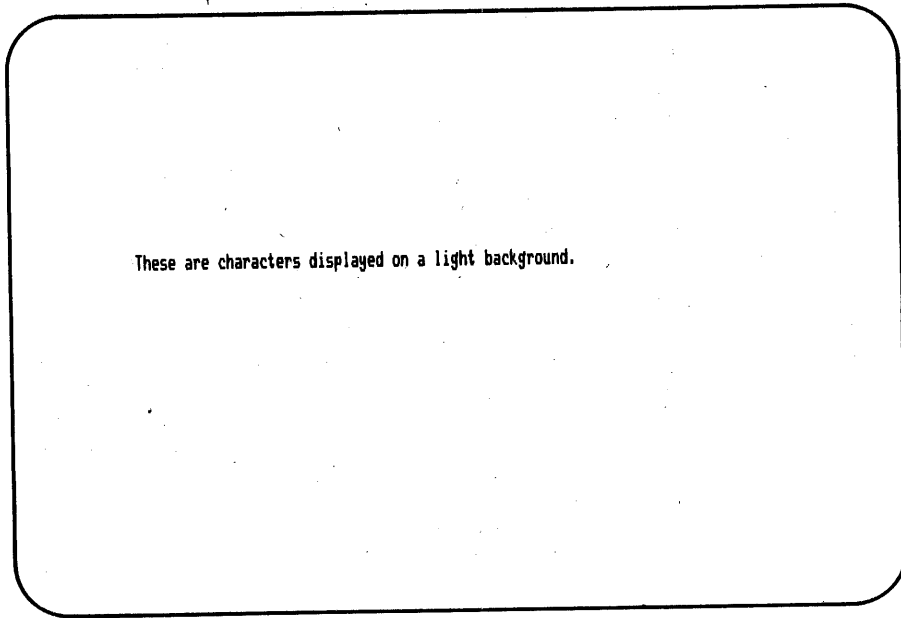

MA-7812

Figure 4-9 Screen Background

In full duplex communication, the auto XON/XOFF feature is used to prevent the loss of received characters. When this feature is on, the terminal transmits the XON and XOFF control characters to indicate when the input character buffer is almost empty or full. When the input character buffer is almost full the terminal transmits XOFF (DC3, octal 023). The computer should stop transmitting characters.

As the terminal continues to remove characters from the input character buffer, the number of characters in the buffer decreases. When the input buffer is almost empty, the terminal transmits XON (DC1, octal 021). The computer should continue transmitting characters.

When the auto XON/XOFF feature is selected, the VT131 terminal keyboard character buffer is also controlled with the XON/XOFF control characters. If the VT131 terminal receives the XOFF character, characters are not transmitted. When the XON character is received, characters are again transmitted.

When the auto XON/XOFF feature is off, the terminal does not use the XON and XOFF characters to prevent the loss of received characters. Also, the VT131 terminal ignores the XON and XOFF control characters when received. The NO SCROLL key, which uses the XON and XOFF control characters, does not function.

NOTE: The XON/XFF control characters are used with the printer interface regardless of the auto XON/XOFF SET-UP feature selection.

U.S./U.K. Character Set Switch 3-1: 0 = #, 1 = £
The U.S./U.K. character set feature selects either the United States or United Kingdom character sets. The difference between the two character sets is one character, the # (number) or £ (pound) symbol.

Auto Wrap Switch 3-2: 0 = Off, 1 = On
The auto wrap feature selects where a received character is displayed when the cursor is at the right margin. When the auto wrap feature is off, the character and all following characters are written into the last column of the current line. When this feature is on, the character is automatically displayed on the next line.

NOTE: The auto wrap feature does not transmit the carriage return or line feed characters to the computer when moving to the next line.

Line Feed/New Line Switch 3-3: 0 = Off, 1 = On
The line feed/new line feature selects the control character(s) transmitted by the RETURN key and the action taken by the terminal when a line feed (LF) is received.

When the line feed/new line feature is off, pressing the RETURN key generates the carriage return (CR) control character. When a line feed (LF) control character is received the cursor moves down to the next line maintaining the current column position.

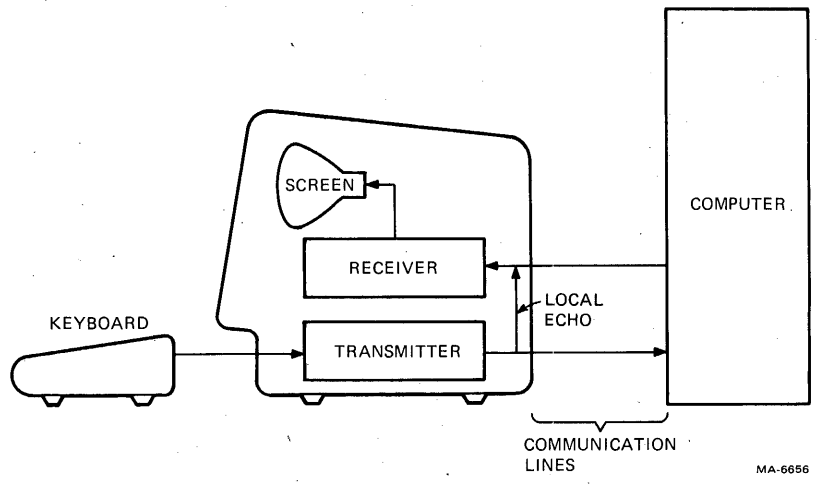

Figure 4-10 Local Echo

Receive Parity Switch 4-4: 0 = Ignore, 1 = Check
The received parity feature allows the parity bit of all character received from the computer to be either checked or ignored. If the feature is set to Check, the parity bit of the received characters is checked according to the parity SET-UP feature selection. If a receive parity error occurs, the terminal displays the substitution character (D) in place of the character with the error. When the feature is set to ignore, any parity bit received is ignored.

NOTE: This feature is used to check the received characters for either odd or even parity, mark and space parity are not checked.

Break Enable Switch 5-1: 0 = Off, 1 = On
The break enable feature determines if a break signal is transmitted when the BREAK key is pressed. If this feature is on, pressing the BREAK key causes the break signal to be transmitted. If this feature is off, the BREAK key does not function when pressed alone. All other key sequences using the BREAK key are not affected. For more information about the break signal refer to Chapter 7.

Disconnect Char Enable Switch 5-2: 0 = Off, 1 = On
The disconnect character enable feature determines if the terminal disconnects from the communication line when the disconnect character is received. When this feature is on, the terminal disconnects when the disconnect character is received. Also, the terminal automatically transmits the disconnect character when a long break disconnect is generated. (For more information about a long break disconnect refer to Chapter 7.) When this feature is off, received control characters do not cause a communication line disconnect.

The disconnect character is determined by the turnaround/disconnect SET-UP feature. For more information about turnaround characters refer to the turnaround/disconnect character SET-UP feature.

Disconnect Delay (FDX) Switch 5-3: 0 = U.K., 1 = Other
The disconnect delay feature is only used when the modem control SET-UP feature is set to full duplex with modem control (FDX B or FDX C). The disconnect delay feature determines the time allowed before the terminal disconnects from the communication line when the receive line signal detection (RLSD) is lost.

In the United Kingdom, the telephone system transmits a dial tone .060 seconds after RLSD is lost. For most other installations, the dial tone is transmitted after 2 seconds. Refer to Chapter 7 for details about communication line disconnects.

NOTE: In the United States this feature is always selected for Other (1).

Auto Answerback

Switch 5-4: 0 = Off, 1 = On

The auto answerback feature causes the terminal to automatically transmit the answerback message when a connection is made to the computer. When using half duplex communication, the answerback message is not transmitted until the VT131 terminal can transmit. This feature does not affect the transmission of the answerback message when using the CTRL and BREAK key sequence. Refer to the answerback feature description for more information about the answerback message.

Initial Direction (HDX) Switch 6-1: 0 = RCV, 1 = XMIT

The initial direction feature is only used when the modem control SET-UP feature is selected to half duplex (HDX A or HDX B). The feature determines if the terminal begins half duplex communication by receiving (RCV) or transmitting (XMIT).

Auto Turnaround (HDX) Switch 6-2: 0 = Manual, 1 = Auto

The auto turnaround feature is only used when the modem control SET-UP feature is selected to half duplex coded control (HDX B). The feature causes the turnaround character (selected by the turnaround/disconnect character SET-UP feature) to be transmitted automatically. The turnaround character is automatically transmitted after:

the characters transmitted by the RETURN key

the end of the answerback message

NOTE: If the turnaround character selected is a carriage return (CR), the RETURN key does not generate two CR control characters.

When this feature is selected as manual, the turnaround character must be generated using a CTRL key combination. Refer to Chapter 5 when generating control characters using the CTRL key.

Reserved Switch 6-3: Always = 0

Reserved Switch 6-4: Always = 0

Power Switch 7-1: 0 = 60 Hz, 1 = 50 Hz

The power feature must be selected to match the power line frequency. In the United States this is usually 60 Hz (0). When using 50 Hz line frequency select this feature for 50 Hz (1).

WPS Terminal Switch 7-2: 0 = Off, 1 = On

This feature is used when the terminal is used as a word processing terminal. On the word processing keyboard the position of the LINE FEED and / (backslash) keys are changed. Otherwise, this feature is off (0).

Clock Switch 7-3: Always = 1

Reserved Switch 7-4: Always = 0

Modem Data/Parity Bits

The modem data/parity feature defines two separate but related communication features: data bits per character and parity used when communicating with the computer. Data bits per character defines the number of data bits in the transmit and receive characters, 7 or 8 bits. However, when 8 bits is selected, the 8th bit is set to a space (or 0) for characters transmitted. The 8th bit of all characters received is ignored.

Parity defines the type of parity bit the terminal generates when transmitting characters and checks when receiving characters. However to check the parity of received characters, the receive parity SET-UP feature must be set to Check. When the receive parity SET-UP feature is used the parity selection must be either odd or even. If no parity is selected, the parity bit is not included in the transmitted character and ignored in received characters. The terminal uses one of the data bits per character/parity combinations shown in Table 4-3. Select the modem data/parity bits feature using the following procedure.

- | PROCEDURE | INDICATION/COMMENTS |
|--|---|
| 1. Press the SET-UP key to enter SET-UP. | SET-UP A is displayed on the screen. |
| 2. Press the SET-UP A/B/C key to enter SET-UP B. | SET-UP B is displayed on the screen. When entering SET-UP B the modem features are automatically selected. |
| 3. If the modem features are not selected; hold down the SHIFT key, press the <- (left arrow) key and release both keys. | The modem features are shown in reverse video when selected. |
| 4. Hold down the SHIFT key, press the P key and release both keys to select the feature. | Each time this key combination is pressed, the terminal selects another data bits per character/parity combination. |
| 5. Press the SET-UP key to exit SET-UP, | The characters displayed on the screen before entering SET-UP are displayed. |

or

press the SETUP A/B/C key to enter SET-UP C. SET-UP C is displayed on the screen.

Table 4-3 Modem Data/Parity Bits Selections

P=	Data Bits	Description Per Character	Parity
7M	7		mark
7S	7		space
7O	7		odd
7E	7		even
7N	7		no parity bit
8O	8		odd
8E	8		even
8N	8		no parity bit

Modem Transmit Speed

The modem transmit speed feature selects the speed (baud rate) of characters transmitted by the terminal. The modem transmit speed feature must be selected to match the computer receive speed. The terminal transmits characters at any one of the following speeds: 50, 75, 110, 134.5, 150, 200, 300, 600, 1200, 1800, 2000, 2400, 3600, 4800, 9600, and 19,200 baud. The transmit speed is not related to the receive speed; the terminal can transmit characters at one speed and receive characters at a different speed. Select the modem transmit speed using the following procedure.

- | PROCEDURE | INDICATION/COMMENTS |
|---|--|
| 1. Press the SET-UP key to enter SET-UP. | SET-UP A is displayed on the screen. |
| 2. Press the SETUP A/B/C key to enter SET-UP B. | SET-UP B is displayed on the screen. |
| 3. If the modem features are not selected; hold down the SHIFT key, press the <- (left arrow) key and release both keys. | The modem features are shown in reverse video when selected. |
| 4. Press the TRANSMIT SPEED key to select the transmit speed. | The terminal displays the current feature selection. |
| 5. Press the SET-UP key to exit SET-UP, | The characters displayed on the screen before entering SET-UP are lost. When exiting SET-UP the screen is blank. |
| or | |
| press the SETUP A/B/C key to enter SET-UP C. | SET-UP C is displayed on the screen. |

Modem Receive Speed

The modem receive speed feature selects the speed (baud rate) at which the terminal receives characters. The modem receive speed feature must be selected to match the computer transmit speed. The terminal receives characters at any one of the following speeds: 50, 75, 110, 134.5, 150, 200, 300, 600, 1200, 1800, 2000, 2400, 3600, 4800, 9600, and 19,200 baud. The receive speed is not related to the transmit speed; the terminal can receive characters at one speed and transmit characters at a different speed. Select the modem receive speed feature using the following procedure.

- | PROCEDURE | INDICATION/COMMENTS |
|---|--------------------------------------|
| 1. Press the SET-UP key to enter SET-UP. | SET-UP A is displayed on the screen. |

2. Press the **SETUP A/B/C** key to enter **SET-UP B** is displayed on the screen.
3. If the modem features are not selected; hold down the **SHIFT** key, press the **<-** (left arrow) key and release both keys. The modem features are shown in reverse video when selected.
4. Press the **RECEIVE SPEED** key to select the receive speed. The terminal displays the current feature selection.
5. Press the **SET-UP** key to exit **SET-UP**, before entering **SET-UP** are displayed. The characters displayed on the screen

or

press the **SETUP A/B/C** key to enter **SET-UP C** is displayed on the screen.

Modem Control

The modem control feature selects half or full duplex communication with the computer. This feature selection must match the computers communication type. The modem control feature selections are listed in Table 4-4. For more information about the modem control **SET-UP** feature selections refer to Chapter 7. Select the modem control feature using the following procedure.

PROCEDURE	INDICATION/COMMENTS
1. Press the SET-UP key to enter SET-UP .	SET-UP A is displayed on the screen.
2. Press the SETUP A/B/C key to enter SET-UP B .	SET-UP B is displayed on the screen.
3. If the modem features are not selected; hold down the SHIFT key, press the <- (left arrow) key and release both keys.	The modem features are shown in reverse video when selected.
4. Hold down the SHIFT key, press the M key and release both keys to select the feature.	Each time this key combination is pressed, the terminal selects another modem protocol selection.

Table 4-4 Modem Control Selections

Selection	Description	Usual Application
FDX A	Full duplex no EIA modem control (data leads only)	Full duplex communication with a null modem (direct) connection to the computer or with a modem that does not use EIA modem controls.
FDX B	Full duplex with EIA modem control	Full duplex communication with a modem that uses EIA modem controls.
FDX C	Asymmetric full duplex with EIA modem control	Full duplex communication with a half duplex modem using the secondary channel.
HDX A	Half duplex supervisory mode	Half duplex communication with the secondary channel control lines indicating when to perform line turnarounds.
HDX B	Half duplex coded control	Half duplex communication with control characters indicating when to perform line turnarounds.

5. Press the SET-UP key The characters displayed on the screen key to exit SET-UP, before entering SET-UP are displayed.

or

press the SETUP A/B/C SET-UP C is displayed on the screen.
key to enter SET-UP C.

Turnaround (End of Character Block)/Disconnect Character

The turnaround (end of character block)/disconnect character feature selects:

- ^ The turnaound character used with half duplex coded control (HDX B) modem protocol SET-UP feature selection.
- ^ The end of block character used with all other modem protocol selections to indicate the end of a block of characters. The end of block character is used while in edit mode.
- ^ This feature also selects the disconnect character used in all half or full duplex modem control SET-UP feature selections.

The turnaround/disconnect character selections are listed in Table 4-5. Select the turnaround/disconnect character using the following procedure.

NOTE: When the modem control SET-UP feature selection is half duplex coded control (HDX B), a turnaround character must be selected. The CR and DC3 control characters are not recommended for use as turnaround characters. The use of these characters as turnaround characters is not allowed in ANSI X3.4-1977. DC3 should only be selected when the auto XON/XOFF SET-UP feature is off.

PROCEDURE	INDICATION/COMMENTS
1. Press the SET-UP key to enter SET-UP.	SET-UP A is displayed on the screen.
2. Press the SETUP A/B/C key to enter SET-UP B.	SET-UP B is displayed on the screen.
3. If the modem features are not selected; hold down the SHIFT key, press the <- (left arrow) key and release both keys.	The modem features are shown in reverse video when selected.
4. Hold down the SHIFT key, press the C key and release both keys to select the feature.	Each time this key combination is pressed, the terminal selects another turnaround and disconnect character selection.

Table 4-5 Turnaround(End of Block)/Disconnect Character Selections

Turnaround Character (HDX B only) End of Block		Disconnect Character	
Name	Mnemonic	Name	Mnemonic
None		None	
Form Feed	FF	End Of Transmission	EOT
End Of Text	ETX	End Of Transmission	EOT
End Of Transmission	EOT	Data Link Escape - End Of Transmission	DLE EOT
Carriage Return	CR	End Of Transmission	EOT
Device Control 3	DC3	End Of Transmission	EOT

5. Press the **SET-UP** key. The characters displayed on the screen before entering **SET-UP** are displayed.

or

press the **SETUP A/B/C** key. **SET-UP C** is displayed on the screen.
key to enter **SET-UP C**.

Printer Data/Parity Bits

The printer data/parity bits feature defines two separate but related communication features: data bits per character and parity used when communicating with the printer. Data bits per character defines the number of data bits (7 or 8 bits) of the transmit and receive characters. However, when 8 bits is selected, the 8th bit is set to a space (or 0) for characters transmitted. The 8th bit of all characters received is ignored.

Parity defines the type of parity bit the terminal generates when transmitting characters and checks when receiving characters. If no parity is selected, the parity bit is not included in the transmitted character and ignored in received characters. The terminal uses one of the data bits per character/parity combinations shown in Table 4-6. Select the printer data/parity bits feature use the following procedure.

NOTE: The serial printer should not transmit characters to the VT131 terminal. However, the VT131 terminal can use the XON and XOFF control characters from the printer to prevent input buffer overflows of the printer.

PROCEDURE	INDICATION/COMMENTS
1. Press the SET-UP key to enter SET-UP .	SET-UP A is displayed on the screen.
2. Press the SET-UP A/B/C key to enter SET-UP B .	SET-UP B displayed on screen. When first entering SET-UP B the modem features are selected.
3. If the modem features are selected; hold down the SHIFT key, press the -> (right arrow) key and release both keys.	The printer features are shown in reverse video when selected.
4. Hold down the SHIFT key, press the P key and release both keys to select the feature.	Each time this key combination is pressed, the terminal selects another data bits per character/parity combination.

5. Press the SET-UP key The characters displayed on the screen key to exit SET-UP, before entering SET-UP are displayed.

or

press the SETUP A/B/C SET-UP C is displayed on the screen. key to enter SET-UP C.

Printer Receive/Transmit Speed

The printer receive/transmit speed feature selects the speed (baud rate) that characters are transmitted between the VT131 terminal and the printer. The receive and transmit speeds of the printer interface are always the same (different receive and transmit speeds are not provided). The receive and transmit speed of the printer interface must be set to match the serial printer transmit and receive speeds. The printer interface uses one of the following receive/transmit speeds: 50, 75, 110, 134.5, 150, 200, 300, 600, 1200, 1800, 2000, 2400, 3600, 4800, 9600, and 19,200 baud. Select the printer interface receive/transmit speeds using the following procedure.

NOTE: The printer interface uses one stop bit per character for all speed selections greater than 110. Two stop bits per character are used for all speed selections of 110 or less.

PROCEDURE	INDICATION/COMMENTS
1. Press the SET-UP key to enter SET-UP.	SET-UP A displayed on screen.
2. Press the SET-UP A/B/C key to enter SET-UP B.	SET-UP B displayed on screen. When first entering SET-UP B the modem features are selected.
3. If the modem features are selected; hold down the SHIFT key, press the -> (right arrow) key and release both keys.	The printer features are shown in reverse video when selected.
4. Press either the TRANSMIT or RECEIVE SPEED keys to select the speed.	The SET-UP display shows the feature selection. Either key may be used to select the baud rate.
5. Press the SET-UP key key to exit SET-UP,	The characters displayed on the screen before entering SET-UP are displayed.

or

press the SETUP A/B/C SET-UP C is displayed on the screen. key to enter SET-UP C.

Table 4-6 Printer Data/Parity Bits Selections

P=	Description	Parity
	Data Bits Per Character	
7M	7	mark
7S	7	space
7O	7	odd
7E	7	even
7N	7	no parity bit
8O	8	odd
8E	8	even
8N	8	no parity bit

Answerback

The answerback feature provides the terminal with an identifying message that can be transmitted to the computer. The answerback message is transmitted under the following conditions.

- The answerback message is transmitted under a direct request for identification by the computer. The computer transmits the Enquire (ENQ, octal 005) control character and the terminal responds with the answerback message. The entire sequence takes place automatically without affecting the screen or needing operator action.
- The operator manually transmits the answerback message from the keyboard. Hold down the CTRL key, press the BREAK key and release both keys to manually transmit the answerback message.

Enter the answerback message using the following procedure.

PROCEDURE	INDICATION/COMMENTS
1. Press the SET-UP key to enter SET-UP.	SET-UP A is displayed on the screen.
2. Press the SETUP A/B/C key to enter SET-UP B.	SET-UP B is displayed on the screen.
3. Hold down the SHIFT key, press the A key and release both keys.	The terminal displays A = (refer to Figure 4-11).
4. Type the message delimiter character.	This is any character not used in the answerback message. The message delimiter character is not transmitted as part of the answerback message.
5. Type the answerback message.	The answerback message may be up to 20 characters. If control characters are used they are displayed as the (<>) character. If a mistake is made while typing the message, type the delimiter character (used in step 4) and go back to step 3. This is the only way to correct errors in the answerback message.
6. If less than 20 characters are in the message, type the delimiter character.	If 20 characters are typed, the message is automatically entered into operating memory. If less than 20 characters are typed the delimiter character is used to enter the message into operating memory.

NOTE: The answerback message can be held in user memory if a store is performed.

SET-UP B
TO EXIT PRESS "SET-UP"

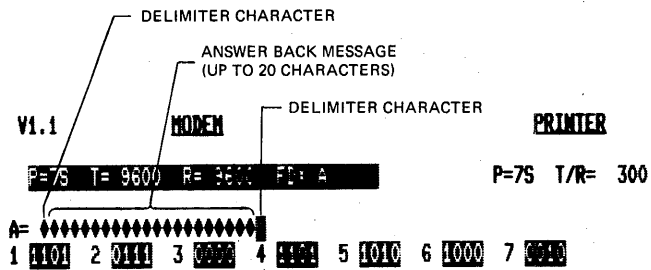

MA-9362

Figure 4-11 Answerback Message Summary

7. Press the **SET-UP** key The characters displayed on the screen
key to exit SET-UP, before entering SET-UP are lost. When
or exiting SET-UP the screen is blank.

press the **SETUP A/B/C** SET-UP C is displayed on the screen.
key to enter SET-UP C.

SET-UP C

SET-UP C can only be entered from SET-UP B. The SET-UP C display is similar to Figure 4-12. Figure 4-13 summarizes the SET-UP C display features. The bottom line of the display shows groups of switches indicating the features selected. Change these SET-UP features using the following procedure.

PROCEDURE	INDICATION/COMMENTS
1. Press the SET-UP key to enter SET-UP.	SET-UP A is displayed on the screen.
2. Press the SET-UP A/B/C key to enter SETUP B.	SET-UP B is displayed on the screen.
3. Press the SET-UP A/B/C key to enter SETUP C.	SET-UP C is displayed on the screen.
4. Position the cursor over the SET-UP feature switch to be changed.	The cursor is positioned using the < (left arrow), > (right arrow), RETURN , TAB and SPACE BAR keys.
5. Use the TOGGLE 1/0 key to select the feature.	The screen displays the feature selection.
6. Press the SET-UP key key to exit SET-UP,	The characters displayed on the screen before entering SET-UP are displayed.

or

press the **SETUP A/B/C** SET-UP A is displayed on the screen.
key to enter SET-UP A.

The following paragraphs describe the features in the order of the switches on the screen. The switches are referred to within this chapter by the group and the number of the switch within the group. (Example: switch C-2 is the third group of switches - second switch counting from left to right.

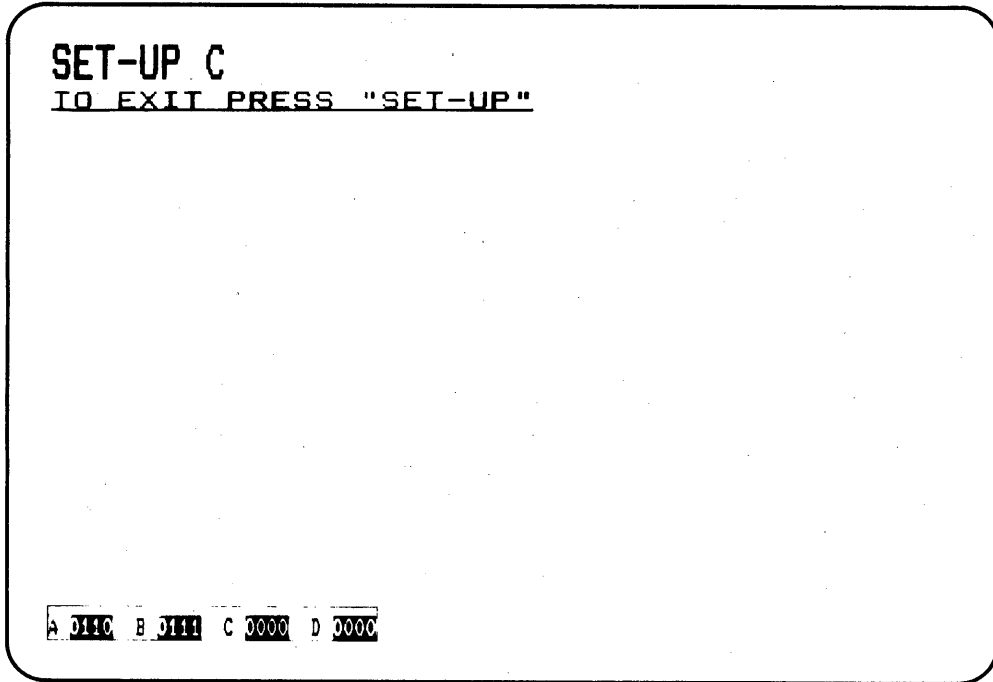

MA-3574

Figure 4-12 SET-UP C Display

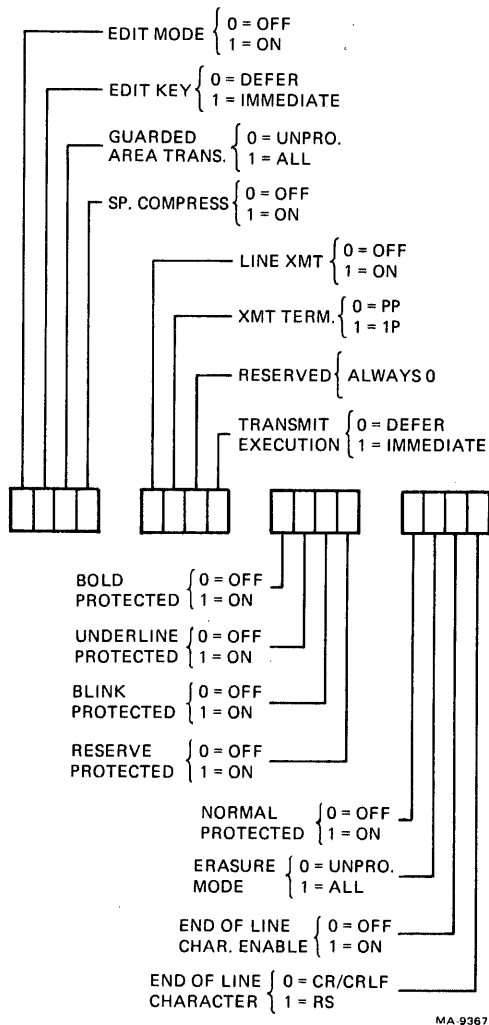

MA-9367

Figure 4-13 SET-UP C Summary

Edit Mode Switch A-1: 0 = Off, 1 = On
The edit mode feature determines if the terminal operates as an editing (on) or interactive (off) terminal. As an interactive terminal typed characters are transmitted to the computer immediately. As an editing terminal typed characters are held within the terminal for editing. When editing is complete the characters are transmitted (as a block of characters) to the computer. This feature does not affect the use of the EDIT key.

Edit Key Switch A-2: 0 = Deferred, 1 = Immediate
The SHIFT and EDIT key sequence selects interactive and editing operation. The edit key feature determines how the EDIT key operates. When this feature is selected to deferred, the SHIFT and EDIT key sequence transmits a sequence of characters to the computer. When these characters are echoed back to the terminal, the terminal changes between interactive and editing operation. When selected for immediate, this key sequence selects either interactive or editing operation immediately.

Guarded Area Transfer Switch A-3: 0 = Unprotected, 1 = All
When operating as an editing terminal, characters on the screen are either protected or unprotected. Protected characters can not be edited from the keyboard, unprotected characters can be edited. The guarded area transfer feature determines which characters on the screen are transmitted to the computer. When selected for all, all characters on the screen are transmitted. When selected for unprotected, only the unprotected characters are transmitted.

Space Compression Switch A-4: 0 = Off, 1 = On
When transmitting edited characters, this feature determines if the unused character positions on the screen are transmitted as space characters or as a single control character representing the remaining spaces of a field.

Line Transmit Switch B-1: 0 = Off, 1 = On
This feature determines the size of the block of characters transmitted to the computer in edit mode. When this feature is off, the transmit termination SET-UP feature determines the size of the block of characters transmitted. When on, this feature causes one line of characters to be transmitted each time the RETURN or ENTER key is pressed.

Transmit Termination Switch B-2: 0 = Par. Page, 1 = Full Page
The transmit termination feature determines if a block of characters transmitted to the computer as a full (1) or partial (0) page. Full page transmits all the characters within the margins. Partial page transmits the characters between a partial page marker and cursor. If a partial page marker is not present, the top margin is used. The marker (which is not displayed) is automatically positioned at the last character transmitted. The transmission characters is started by using the ENTER key.

Reserved Switch B-3: Always = 0

Transmit Execution Switch B-4: 0 = Defered, 1 = Immediate
The transmit execution feature determines how the ENTER key operates. When defered is selected, the terminal transmits a character sequence to request a block character transmission. When the computer is ready to receive the characters, it transmits a sequence of characters to begin transmission. When immediate is selected, the terminal transmits the characters when the key is pressed.

Bold Protected Switch C-1: 0 = Off, 1 = On
When editing, this feature determines if the bold characters are protected. Protected characters can not be edited from the keyboard.

Underline Protected Switch C-2: 0 = Off, 1 = On
When editing, this feature determines if the underlined characters are protected. Protected characters can not be edited from the keyboard.

Blink Protected Switch C-3: 0 = Off, 1 = On
When editing, this feature determines if the blinking characters are protected. Protected characters can not be edited from the keyboard.

Reverse Protected Switch C-4: 0 = Off, 1 = On
When editing, this feature determines if the reverse video characters are protected. Reverse video characters are characters displayed with a screen background opposite of the screen background selected by the screen background SET-UP feature. Protected characters can not be edited from the keyboard.

Normal Protected Switch D-1: 0 = Off, 1 = On
When editing, this feature determines if the characters without bold, blink, underline or reverse video are protected. Protected characters can not be edited from the keyboard.

Erasure mode Switch D-2: 0 = Unprotected, 1 = All
Erasure mode determines which characters on the screen can be edited by the computer. When unprotected is selected, only unprotected characters can be edited by the computer. When all is selected, all characters displayed on the screen can be edited by the computer.

End of Line Character Switch D-3: 0 = Off, 1 = On
Enable
The end of line character enable feature determines if an end of line character is transmitted during a block transmission.

End of Line Character Switch D-4: 0 = CR/CRLF, 1 = RS
The end of line character feature determines the character used to indicate the end of a line during block transmission. The end of line character can be the character(s) transmitted by the RETURN key or the RS character. The line feed/new line SET-UP feature determines the character(s) transmitted by the RETURN key.

NOTE: When the end of transmission character is selected as CR, the end of line character is RS regardless of the end of line character SET-UP feature selection.

CHAPTER 5 TRANSMITTED CHARACTERS

GENERAL

This chapter describes the character codes generated by the VT131 terminal. The keys are divided into three groups: standard keys, function keys and the auxiliary keypad keys.

STANDARD KEYS

The standard keys are shown in Figure 5-1. The terminal generates American Standard Code for Information Interchange (ASCII) character codes. Lowercase ASCII character codes are generated when neither of the SHIFT keys are pressed and the CAPS LOCK is not down. Uppercase ASCII character codes are generated when either of the SHIFT keys are pressed. When the CAPS LOCK key is down, the 26 alphabetic keys generate uppercase character codes. The CAPS LOCK key does not affect the nonalphabetic keys of the keyboard.

FUNCTION KEYS

The function keys are shown in Figure 5-2. These keys generate character codes whose function is defined by the computer software or communication system. The following paragraphs describe the function keys of the terminal.

BREAK Key

The BREAK key causes the generation of a Break signal when the break enable SET-UP feature is on. When the break enable SET-UP feature is off, the BREAK key does not generate the break signal. All other keys sequences using the BREAK key are not affected. The use of the Break signal is defined by the computer system. Refer to Chapter 7 for more information about the Break signal.

Hold down the SHIFT key and press the BREAK key to generate a long break disconnect. A long break disconnect usually disconnects the terminal from the communication line. Refer to Chapter 7 for more information about long break disconnects.

Hold down the CTRL key and press the BREAK key to generate the answerback message. Refer to Chapter 4 for more information about the answerback SET-UP feature.

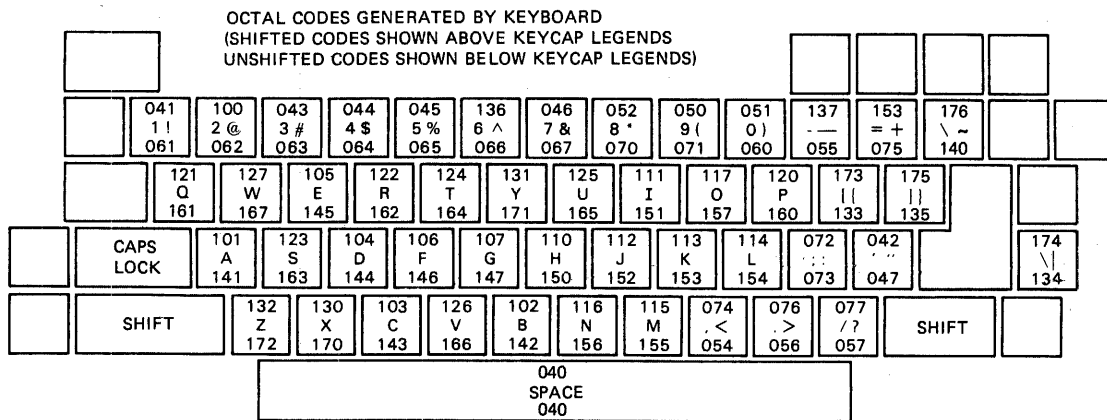

MA-7418A

Figure 5-1 Standard Key Codes

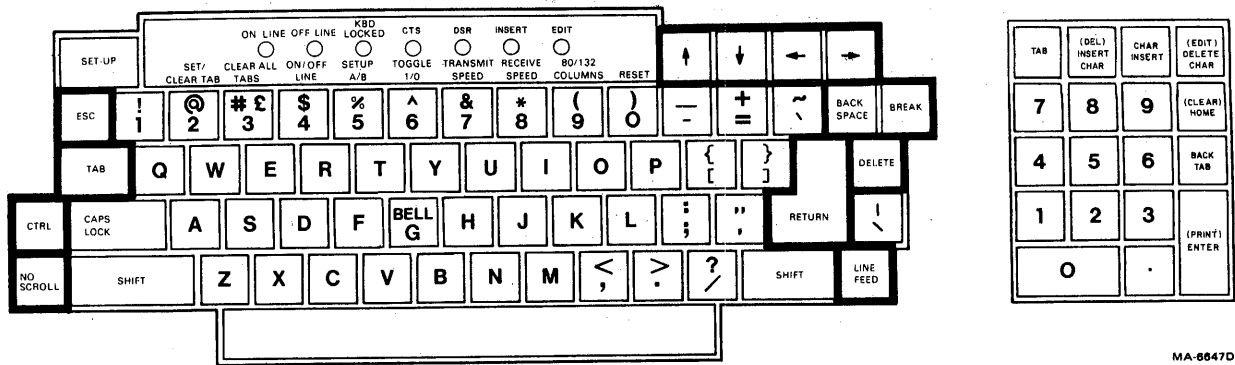

MA-6647D

Figure 5-2 VT131 Function Keys

↑ ↓ ← → Keys

The cursor key character codes generated by the terminal depend on the ANSI/VT52 feature. When the ANSI/VT52 feature is selected for ANSI, the keypad mode selection determines if cursor key mode is used. When alternate (application) keypad mode is selected, the cursor keys generate either application or cursor control sequences as selected by cursor key mode. When numeric keypad mode is selected, the cursor keys generate ANSI cursor commands. Both cursor key mode and alternate/numeric keypad mode are selected by the computer. Refer to Chapter 6 for more information about cursor key character selection.

When the ANSI/VT52 feature is selected for VT52, the cursor keys generate VT52 cursor control sequences. The ANSI and VT52 compatible cursor key character codes are listed in Table 5-1.

Control Character Keys

Table 5-2 lists the control characters generated by the terminal. Figure 5-3 shows the keys used to generate control characters. Control characters can be generated in two ways:

- ^ Hold down the CTRL key and press any of the unshaded keys in Figure 5-3.
- ^ Press any of the shaded keys in Figure 5-3 without using the CTRL key. The shaded keys are dedicated keys used to generate control characters without the use of the CTRL key.

No details are provided about the function of the control character codes because different computer systems may use each control character differently.

NOTE: The terminal generates some control codes differently from previous DEC terminals (VT52 terminal). Table 5-3 lists the keys used by the terminal and the previous terminals to generate the control characters.

AUXILIARY KEYPAD KEYS

The characters generated by the auxiliary keypad keys change depending on the selection of the ANSI/VT52 feature and alternate (application) keypad mode. The alternate (application) keypad mode is selected by the computer. Refer to Chapter 6 for more information about Keypad Character Selection.

When alternate (application) keypad mode is not selected (Numeric keypad mode is selected), the auxiliary keypad generates the numeric, comma, period and minus sign character codes used by the main keyboard. When alternate (application) keypad mode is selected, the auxiliary keypad generates control functions. The character codes generated by the auxiliary keypad are listed in Table 5-4.

MNEMONICS SHOWN ABOVE KEYCAP LEGENDS
OCTAL CODES SHOWN BELOW KEYCAP LEGENDS

ESC ESC 033														RS ~ 036	BS SPACE 010
HT TAB 013	XON Q 021	ETB W 027	ENQ E 005	DC2 R 022	DC4 T 024	EM Y 031	NAK U 025	HT I 011	SI O 017	DLE P 020	ESC 033	GS 035		DEL DELETE 177	
CTRL		SOH A 001	XOFF S 023	EOT D 004	ACK F 006	BEL G 007	BS H 010	LF J 012	VT K 013	FF L 014	::	"	CR RETURN 015	FS \ 034	
		SUB Z 032	CAN X 030	ETX C 003	SYN V 026	STX B 002	SO N 016	CR M 015	.<	.>	US /? 037		LF LINE FEED 012		
NUL 000															

MA-7419A

Figure 5-3 Function Key Control Codes

Table 5-1 Cursor Control Key Codes

Cursor Key (arrow)	ANSI MODE			VT52 MODE		
	Cursor Key Mode Reset		Cursor Key Mode Set			
Up	ESC [A Ø33 133 1Ø1		ESC O A Ø33 117 1Ø1		ESC A Ø33 1Ø1	
Down	ESC [B Ø33 133 1Ø2		ESC O B Ø33 117 1Ø2		ESC B Ø33 1Ø2	
Right	ESC [C Ø33 133 1Ø3		ESC O C Ø33 117 1Ø3		ESC C Ø33 1Ø3	
Left	ESC [D Ø33 133 1Ø4		ESC O D Ø33 117 1Ø4		ESC D Ø33 1Ø4	

Table 5-2 Control Codes Generated

Control Character	Character Mnemonic	Transmitted Code (Octal)	Key Pressed with CTRL Key Down	Dedicated Key
Null	NUL	000	Space Bar	
Start of Heading	SOH	001	A	
Start of Text	STX	002	B	
End of Text	ETX	003	C	
End of Transmission	EOT	004	D	
Enquire	ENQ	005	E	
Acknowledge	ACK	006	F	
Bell	BEL	007	G	
Back Space	BS	010	H	BACK SPACE
Horizontal Tabulation	HT	011	I	TAB
Line Feed	LF	012	J	LINE FEED
Vertical Tabulation	VT	013	K	
Form Feed	FF	014	L	
Carriage Return	CR	015	M	RETURN
Shift Out	SO	016	N	
Shift In	SI	017	O	
Data Link Escape	DLE	020	P	
Device Control 1	DC1 (XON)	021	Q	
Device Control 2	DC2	022	R	
Device Control 3	DC3 (XOFF)	023	S	
Device Control 4	DC4	024	T	
Negative Acknowledge	NAK	025	U	
Synchronous Idle	SYN	026	V	
End of Transmission Block	ETB	027	W	
Cancel Previous Word or Character	CAN	030	X	
End of Medium	EM	031	Y	
Substitute	SUB	032	Z	
Escape	ESC	033	[
File Separator	FS	034	\	
Group Separator	GS	035]	
Record Separator	RS	036	~	
Unit Separator	US	037	?	
Delete	DEL	177		DELETE

* Depending on the auxiliary keypad mode selected, the RETURN and ENTER keys may generate the same control codes. The codes generated by the RETURN key are changed by the feature selections of the terminal. The feature that change the codes generated by the RETURN key are:

^ The auto turnaround SET-UP feature when the modem protocol SET-UP feature is selected for HDX B. The turnaround character generated by the key is selected by the turnaround/disconnect SET-UP feature. If carriage return is selected as the turnaround character, only one carriage return is transmitted when the RETURN key is pressed.

Table 5-2 Control Codes Generated (Cont)

Control Character	Character Mnemonic	Transmitted Code (Octal)	Key Pressed with CTRL Key Down	Dedicated Key
-------------------	--------------------	--------------------------	--------------------------------	---------------

^ The line feed/new line feature. When this feature is on, the RETURN key generates a carriage return (CR) and line feed (LF). When this feature is off, the RETURN key generates a carriage return (CR).

Table 5-3 VT131 and Previous DEC Terminal Key Differences

Control Code	VT131 Terminal	Previous Terminal
NUL (octal 000)	CTRL Space Bar	CTRL @
RS (octal 036)	CTRL ~	CTRL ^
US (octal 037)	CTRL ?	CTRL -

Table 5-4 Keypad Codes

Key	ANSI MODE			VT52 MODE		
	Numeric Keypad Mode	Alternate (Application) Keypad Mode		Numeric Keypad Mode	Alternate (Application) Keypad Mode	
0	0 060	ESC 0 p 033 117 160		0 060	ESC ? p 033 077 160	
1	1 061	ESC 0 q 033 117 161		1 060	ESC ? q 033 077 161	
2	2 062	ESC 0 r 033 117 162		2 062	ESC ? r 033 077 162	
3	3 063	ESC 0 s 033 117 163		3 063	ESC ? s 033 077 163	
4	4 064	ESC 0 t 033 117 164		4 064	ESC ? t 033 077 164	
5	5 065	ESC 0 u 033 117 165		5 065	ESC ? u 033 077 165	
6	6 066	ESC 0 v 033 117 166		6 066	ESC ? v 033 077 166	
7	7 067	ESC 0 w 033 117 167		7 067	ESC ? w 033 077 167	
8	8 070	ESC 0 x 033 117 170		8 070	ESC ? x 033 077 170	
9	9 071	ESC 0 y 033 117 171		9 071	ESC ? y 033 077 171	
-	-(minus) 055	ESC 0 m 033 117 155		-(minus) 055	ESC ? m 033 077 155	*
,	,(comma) 054	ESC 0 l 033 117 154		,(comma) 054	ESC ? l 033 077 054	*
.	.(period) 056	ESC 0 n 033 117 156		.(period) 056	ESC ? n 033 077 156	
ENTER*	CR or CR LF 015 015 012	ESC 0 M 033 117 115		CR or CR LF 015 015 012	ESC ? M 033 077 115	
PF1	ESC 0 P 033 117 120	ESC 0 P 033 117 120		ESC P 033 120	ESC ? P 033 077 120	
PF2	ESC 0 Q	ESC 0 Q		ESC Q	ESC ? Q	

Table 5-4 Keypad Codes (Cont)

Key	ANSI MODE		VT52 MODE	
	Numeric Keypad Mode	Alternate (Application) Keypad Mode	Numeric Keypad Mode	Alternate (Application) Keypad Mode
	Ø33 117 121	Ø33 117 121	Ø33 121	Ø33 Ø77 121
PF3	ESC O R Ø33 117 122	ESC O R Ø33 117 122	ESC R Ø33 122	ESC ? R Ø33 Ø77 122
PF4	ESC O S Ø33 117 123	ESC O S Ø33 117 123	ESC S Ø33 123	ESC ? S Ø33 Ø77 123 *

* These sequences are not generated by the VT52 terminal.

When numeric keypad mode is selected (alternate keypad mode is off), the ENTER key character code can be changed by the line feed/new line feature. When off, this feature causes the ENTER key to generate a single control character (CR, octal Ø15). When on, this feature causes the ENTER key to generate two characters (CR, octal Ø15 and LF, octal Ø12).

TRANSMISSION OF CHARACTERS IN EDIT MODE

In Edit mode, all characters entered from the keyboard are not transmitted to the computer but are stored in display memory to be edited. On request, the characters are then transmitted to the computer as a block of characters. The transmission of the block of stored characters begins when requested by the keyboard or computer. The keyboard requests transmission when the ENTER key (also RETURN key in line transmit mode DECLTM). The computer requests a transmission using the transmit (DECXMIT) sequence. Once a transmission is initiated, the KBD LOCKED indicator is turned on and the keyboard is locked until the transmission is complete.

NOTE: The keyboard locked condition can be cleared by entering and exiting the SET-UP. This action also clears any pending transmit requests and aborts any transmissions that are in progress.

Transmit execution mode (DECTEM) selects how a block of characters is transmitted. Transmission of the block of characters may be either immediate or deferred. When transmit execution mode is set, depressing the ENTER key starts transmitting the characters immediately. When the transmit execution mode is reset, pressing the ENTER key causes the terminal to transmit the set transmit state (STS) sequence (ESC S, octal 033 123). This sequence notifies the computer that the terminal wants to transmit characters. Transmission is deferred and no further transmission occurs from the terminal until the terminal receives the transmit (DECXMIT) sequence from the computer.

The block of characters transmitted can be one of three block sizes. Line transmit mode (DECLTM) and transmit termination mode (TTM) are used together to determine the size of the character blocks transmitted by the terminal in edit mode. The block sizes are: line, partial page or full page.

When line transmit mode (DECLTM) is set, the terminal transmits the characters of the line containing the cursor regardless of the transmit termination mode (TTM) selection. During a line transmission, the cursor moves to the start of the first unprotected character on the next line with an unprotected field. If the current line is at the end of the scrolling region or there are no more unprotected fields in the scrolling region, the cursor moves to the first unprotected field of the current line.

When line transmit mode (DECLTM) is reset, the terminal transmits the full page or partial page as determined by the transfer termination mode (TTM) selection. When transmit termination mode (TTM) is set, the full scrolling region is transmitted (full page). When transmit termination mode (TTM) is reset, the scrolling region from the upper left hand corner or the last partial page transmit marker to the current cursor position is transmitted (partial page). The partial page marker is a nondisplayable marker in the display memory. If the partial page transmit marker is not present or the cursor is before the marker, the starting point is the beginning of the scrolling region.

Two modes change how many characters of the character block are transmitted. These modes are: space compression/field delimiter mode (DECSCFDM) and guarded area transmit mode (GATM). The effects of combining the two modes is shown in Figure 5-4. If space compression/field delimiter mode (DECSCFDM) is set, all trailing spaces in a field are not transmitted. All fields transmitted are ended by a single record separator character (RS, octal 036) except the last field on a line. This field is delimited by the carriage return character (CR, octal 015) or carriage return, line feed characters (CR LF, octal 015 012).

If space compression/field delimiter mode is reset, all characters are transmitted as they are displayed on the screen. The space character (octal 040) is transmitted if no other character is displayed in a character position.

If the guarded area transmit mode (GATM) is set, protected fields are sent as encountered in the transmit block. If this mode is reset, a single record separator character (RS, octal 036) is transmitted in place of the protected field.

An end of transmission character can be selected to indicate the end of a transmitted block. The transmit termination character sequence (DECTTC) also selects the end of block character. The choices are: no character (function disabled), form feed character (FF, octal 014), end of text (ETX, 003), end of transmission (EOT, 004), carriage return (CR, 015) or device code 3 (DC3, 023).

TEXT

```

I   U   I   U   I   P   I   P   I   P   I
- - - - -
$ 25.00 FOB NO PPD I SBA#134208XXX
    
```

CONDITION	DATA TRANSMITTED
Space compression/field delimiting mode = off Guarded area transfer mode = unprotected only	\$ 25.00 FOB <RS><RS>134208<RS><EOL><ET>
Space compression/field delimiting mode = on Guarded area transfer mode = unprotected only	\$ 25.00 <RS> FOB <RS><RS><RS>134208 <RS><RS><EOL><ET>
Space compression/field delimiting mode = on Guarded area transfer mode = transmit all	\$ 25.00 FOB NO PPD I SBA#134208XXX <EOL><ET>
Space compression/field delimiting mode = on Guarded area transfer mode = transmit all	\$ 25.00<RS> FOB<RS>NO PPD I<RS>SBA#<RS> 134208<RS>XXX<EOL><ET>

- Notes: . Used to indicate the presence of a character location (for graphic purposes only) MA-3666
- I = Field limit (used for graphic purposes only)
 - U = Unprotected Field (used for graphic purposes only)
 - P = Protected Field (used for graphic purposes only)
 - <RS> = Record Separator Character (036a).
 - <ET> = Transmit Termination Character (determined by user).
 - <EOL> = End of Line Character, CR (015a) or CR LF (015a,012a). (The End of Line character used is determined by the setting of the Linefeed/Newline mode.)

Figure 5-4 Space Compression/Field Delimiter and Guarded Area Transfer Mode Interaction

CHAPTER 6 RECEIVED CHARACTER PROCESSING

GENERAL

This chapter describes how the VT131 terminal processes received character codes. The character codes received by the terminal can represent either displayable characters or control functions. All of the displayable characters and control functions used by the VT131 terminal are described in this chapter.

RECEIVED CHARACTERS

The VT131 terminal processes characters in accordance with American National Standards Institute (ANSI) standards X3.64-1979, X3.4-1977 and X3.41-1974. ANSI standard X3.4 defines the American Standard Code for Information Interchange (ASCII) table shown in Table 6-1. Table 6-1 shows each character with its binary, octal, decimal, and hexadecimal values. The ASCII table corresponds to the International Standards Organization (ISO) Standard 646 and International Telegraph and Telephone Consultive Committee (CCITT) Alphabet #5.

The terminal processes a received character based on the type of character as defined by ANSI. The position of the character in the ASCII table determines the type of character as either a displayable character or control function. If the character code is a displayable character, the actual character displayed is determined by the character set selected in the terminal. The ASCII table is 8 columns wide and 16 rows long. The control characters are in columns 0 and 1 of the table. All other characters are displayable characters with the exception of the DElete and SPace characters. The delete character is always a control character. The space character can be considered either an information separator control character or a displayable character.

DISPLAYABLE CHARACTERS

Displayable characters are characters that are displayed on the screen. The actual character displayed on the screen depends on the character set selected in the terminal. The character set is selected using control functions. Refer to the Character Sets and Selection section of this chapter for more information about character sets.

BITS		0 0		0 0 1		0 1 0		0 1 1		1 0 0		1 0 1		1 1 0		1 1 1	
B7 B6 B5		COLUMN		1		2		3		4		5		6		7	
B4	B3	B2	B1	ROW	0	1	2	3	4	5	6	7	8	9	10	11	12
0	0	0	0	0	NUL	DLE	SP	0	@	P	'	p	160	112	70		
0	0	0	1	1	SOH	DC1 (XON)	!	1	A	Q	a	q	161	113	71		
0	0	1	0	2	STX	DC2	"	2	B	R	b	r	162	114	72		
0	0	1	1	3	ETX	DC3 (XOFF)	#	3	C	S	c	s	163	115	73		
0	1	0	0	4	EOT	DC4	\$	4	D	T	d	t	164	116	74		
0	1	0	1	5	ENQ	NAK	%	5	E	U	e	u	165	117	75		
0	1	1	0	6	ACK	SYN	&	6	F	V	f	v	166	118	76		
0	1	1	1	7	BEL	ETB	'	7	G	W	g	w	167	119	77		
1	0	0	0	8	BS	CAN	(8	H	X	h	x	170	120	78		
1	0	0	1	9	HT	EM)	9	I	Y	i	y	171	121	79		
1	0	1	0	10	LF	SUB	*	:	J	Z	j	z	172	122	7A		
1	0	1	1	11	VT	ESC	+	;	K	[k	{	173	123	7B		
1	1	0	0	12	FF	FS	,	<	L	\	l		174	124	7C		
1	1	0	1	13	CR	GS	-	=	M]	m	}	175	125	7D		
1	1	1	0	14	SO	RS	.	>	N	^	n	~	176	126	7E		
1	1	1	1	15	SI	US	/	?	O	_	o	DEL	177	127	7F		

KEY

ASCII CHARACTER	ESC	33	OCTAL
		27	DECIMAL
		1B	HEX

MA-7246

Table 6-1 ASCII Table

CONTROL CHARACTERS

A control character is a single character control function that starts, modifies or stops a control function. Control characters are not displayed but control terminal operation. The control characters recognized by the terminal are described in Table 6-2. All other control characters are ignored.

NOTE: The control characters described in this chapter are assigned a mnemonic. The mnemonic is an abbreviation of the control character name.

ESCAPE AND CONTROL SEQUENCES

Escape and control sequences provide controls not provided by the control characters of the character set. These sequences are multiple character control functions that are not displayed but control terminal operation. Escape and control sequences are defined by ANSI X3.41-1977 and X3.64-1979. Refer to Appendix E for more information about sequences and sequence formats.

The VT131 terminal is an upward and downward software compatible terminal. It can respond to control functions created to meet both private DIGITAL standards and present ANSI standards. Therefore, you can use existing software designed for previous terminals (such as the VT52) or new software that uses the ANSI standards. However, future video terminals will not necessarily be compatible with the private DIGITAL sequences. Therefore, all new software should be designed using ANSI compatible sequences.

The VT131 terminal can use VT52 mode to allow the terminal to respond to private DIGITAL sequences. In VT52 compatible mode, the VT131 terminal responds to private DIGITAL sequences like a VT52 terminal.

The VT131 terminal can use ANSI mode to allow the terminal to respond to a subset of control functions specified by ANSI. All control functions used by the terminal that are not presently specified by ANSI are created to comply with the extensions permitted by the ANSI standards. These sequences are considered ANSI private sequences.

The ANSI compatible control functions listed in this document have a mnemonic assigned by ANSI. If the control function is an ANSI private control function (a function defined by DIGITAL), the mnemonic begins with DEC. Characters in the escape and control sequences are shown using the ASCII character set. The case of the characters used in the sequences is important and must be used as shown. The octal equivalent for each ASCII character in the sequence is presented as a second reference. Refer to Table 6-1 for the decimal and hexadecimal representations of the characters.

The sequences described in this chapter are divided by software compatibility, ANSI or VT52 compatible and are arranged by function (Table 6-3). Appendix D is summary of all control functions.

Table 6-2 Control Characters Recognized by VT131 Terminal

Name	Control Character Mnemonic	Octal Code	Function
Null	NUL	000	Ignored when received (not stored in input buffer) used as a fill character.
End Of Text	ETX	003	This character can be selected as a half duplex turnaround character.
End Of Transmission	EOT	004	This character can be selected as a disconnect character or as a half duplex turnaround character. When used as a turnaround character, the disconnect character is DLE-EOT.
Enquire	ENQ	005	Transmit answerback message.
Bell	BEL	007	Generates a bell tone.
Backspace	BS	010	Moves the cursor to the left one character position, unless it is at the left margin in which case no action occurs.
Horizontal Tab	HT	011	Moves the cursor to the next tab stop, or to the right margin if there are no more tab stops. In edit mode, the tab character is used to position the cursor, the character is not held in memory. When the character is received cursor moves to: <ul style="list-style-type: none"> * the next tab stop or * the next field boundary (if erasure mode is set) * the next unprotected field (if erasure mode is reset) * the last character position of the screen (if the cursor is outside the scrolling region). In edit mode, a tab received with no more tab stops or fields will cause the screen to scroll.
Line Feed	LF	012	Causes a line feed or a new line operation. (Refer to linefeed/new line mode).

Table 6-2 Control Characters Recognized by VT131 Terminal (Cont)

Name	Control Character Mnemonic	Octal Code	Function
Vertical Tab	VT	013	Processed as LF.
Form Feed	FF	014	Processed as LF. This character can also be selected as a half duplex turnaround character.
Carriage Return	CR	015	Move cursor to left margin on the current line. This character can also be selected as a half duplex turnaround character.
Shift Out	SO	016	Select G1 character set, as designated by a Select Character Set sequence.
Shift In	SI	017	Select G0 character set, as designated by a Select Character Set sequence.
Device Control 1	DC1	021	Processed as XON. Causes terminal to continue transmitting characters.
Device Control 3	DC3	023	Processed as XOFF. Causes terminal to stop transmitting all characters except XOFF and XON. This character can also be selected as a half duplex turnaround character.
Cancel	CAN	030	If received during an escape or control sequence, the sequence cancelled and the Substitution character (D) is displayed.
Substitute	SUB	032	Processed as CAN.
Escape	ESC	033	Processed as a sequence introducer.
Delete	DEL	177	Ignored when received (not stored in input buffer).

Table 6-3 Escape and Control Sequence Arrangement

Sequence Arrangement	Page Number
----------------------	-------------

ANSI COMPATIBILITY

SET-UP Feature and Mode Selection.....	
Set mode (SM) and Reset mode (RM)	
ANSI/VT52 Compatibility.....	
ANSI/VT52 mode (DECANM)	
Scrolling.....	
Scroll mode (DECSCLM)	
Scrolling Region.....	
Set Top and Bottom Margins (DECSTBM)	
Origin (Home Position).....	
Origin mode (DECOM)	
Cursor Positioning.....	
Cursor Up (CUU)	
Cursor Down (CUD)	
Cursor Forward (CUF)	
Cursor Backward (CUB)	
Cursor Position (CUP)	
Horizontal and Vertical Position (HVP)	
Index (IND)	
Reverse Index (RI)	
Next Line (NEL)	
Save Cursor (DECSC)	
Restore Cursor (DECRC)	
Columns Per Line.....	
Column mode (DECCOLM)	
Auto Wrap.....	
Auto Wrap mode (DECAWM)	
Screen Background.....	
Screen mode (DECSCNM)	
Line Feed/New Line.....	
Line Feed/New Line mode (LNM)	
Keyboard Action.....	
Keyboard Action mode (KAM)	
Auto Repeat.....	
Auto Repeat mode (DECARM)	
Local Echo.....	
Send-receive mode (SRM)	
Cursor Key Character Selection.....	
Cursor Key mode (DECCKM)	
Keypad Character Selection.....	
Alternate (application) Keypad (DECKPAM)	
Numeric Keypad (DECKPNM)	
Character Set Selection.....	
Select Character Set (SCS)	
Single Shift 2 (SS2)	
Single Shift 3 (SS3)	
Character Attributes.....	
Select Graphic Rendition (SGR)	
Tab Stops.....	
Horizontal Tab Set (HTS)	
Tabulation Clear (TBC)	

Table 6-3 Escape and Control Sequence Arrangement (Cont)

Sequence Arrangement	Page Number
Line Attributes.....	
Double Height Line (DECDHL)	
Single Width Line (DECSWL)	
Double Width Line (DECDWL)	
Erasing.....	
Erase in Line (EL)	
Erase in Display (ED)	
Computer Editing.....	
Delete Character (DCH)	
Insert Line (IL)	
Delete Line (DL)	
Character Insertion-Replacement.....	
Insertion-replacemnt mode (IRM)	
Local Editing (Edit mode).....	
Editing mode (DECEDM)	
Edit Key Execution.....	
Edit Key Execution mode (DECEKEM)	
Character Protection.....	
Protected Fields (DECPRO)	
Erasure mode.....	
Erasure mode (ERM)	
Transmit Execution.....	
Transmit Execution mode (DECTEM)	
Transmission Request.....	
Set Transmit State (STS)	
Transmission Enable.....	
Transmit (DECXMIT)	
Transmit Block Size.....	
Line transmit mode (DECLTM)	
Transmit Page Size.....	
Transfer Termination mode (TTM)	
Space compression/field delimiting.....	
Space compression/field delimiter mode (DECSCFDM)	
Protected Field Transmission.....	
Guarded Area Transfer mode (GATM)	
End of Block Character.....	
Transmit termination character (TTC)	
Printing.....	
Media Copy (MC)	
Printer Extent.....	
Printer Extent mode (DECPEX)	
Printer Termination Character.....	
Printer Form Feed mode (DECPFF)	
Reports.....	
Device Status Report (DSR)	
Cursor Position (CPR)	
Device Attributes (DA)	
Identify Terminal (DECID)	

Table 6-3 Escape and Control Sequence Arrangement (Cont)

Sequence Arrangement	Page Number
----------------------	-------------

Reset.....
 Reset to Initial State (RIS)
Tests and Adjustments.....
 Screen Alignment Display (DECALN)
 Invoke Confidence Test (DECTST)

VT52 COMPATIBLE SEQUENCES

Modes.....
 ANSI/VT52 mode (DECANM)
Keypad Character Selection.....
 Alternate Keypad
 Numeric Keypad
Character Set Selection.....
 Enter Graphics mode
 Exit Graphics mode
Cursor Positioning.....
 Cursor Up
 Cursor Down
 Cursor Forward
 Cursor Backward
 Cursor to Home
 Direct Cursor Address
 Reverse Line Feed
Erasing.....
 Erase to End of Line
 Erase to End of Screen
Printing.....
 Auto Print
 Print Controller
 Print Cursor Line
 Print Screen
Reports.....
 Identify

Error Recovery

Present standards do not specify the action the terminal should perform when a control function is received with an error. Errors include incorrect parameters, invalid control functions or control characters embedded in control function sequences. The terminal generally recovers from these errors by performing as much of the function as possible. The specific error recovery procedures of the VT131 terminal are:

- ^ A control function that is not recognized by the terminal is generally ignored.
- ^ Control functions that are not supported by the terminal (valid control functions not listed in this document) are generally ignored but may not produce expected results.
- ^ If a control character is received within a sequence, the terminal performs the function of the control character, followed by the function of the sequence.
- ^ If the CANCEL (octal 030) or SUBstitute (octal 032) characters are received during a sequence, the current sequence is aborted and the substitute character is displayed. Characters of the sequence received after the SUB or CAN control characters are displayed.

ANSI Compatible Sequences

The ANSI compatible sequences meet ANSI standards X3.64-1979 and X3.41-1974. The ANSI standards allow the manufacturer flexibility in using each function. This section describes the ANSI control functions used by the VT131 terminal. ANSI compatibility is selected from the keyboard in SET-UP (refer to Chapter 2) or by the computer using a sequence (refer to the VT52 Compatible Sequences section of this chapter).

SET-UP Feature and Mode Selection

SET-UP features change how the VT131 terminal operates. These features can be selected by the VT131 keyboard while in SET-UP. Some SET-UP features can also be selected by the computer using control functions. However, features selected by the computer are stored in operating memory. The computer can not store feature selections in user memory. (Refer to Chapter 2 for more information about the SET-UP feature memories.)

Some SET-UP features are modes. A mode is a feature of the terminal that affects operation. The mode selection is used until the computer or operator changes the selection. Table 6-4 lists the SET-UP features and modes. Modes can be changed by the computer using the set mode (SM) and reset mode (RM) sequences. Set and reset the modes of the VT131 terminal using the following sequences.

Table 6-4 SET-UP Features and Modes

SET-UP Feature or Mode	Changed from Computer	Changed from Keyboard in SET-UP
ON/OFF LINE	No	Yes
Screen Brightness	No	Yes
Columns per line	Yes (DECCOLM)	Yes
Tab Stops	Yes (HTS/TBC) *	Yes
Scroll	Yes (DECSCLM)	Yes
Auto Repeat	Yes (DECARM)	Yes
Screen Background	Yes (DECSCNM)	Yes
Cursor	No	Yes
Margin bell	No	Yes
Keyclick	No	Yes
ANSI/VT52	Yes (DECANM)	Yes
Auto XON XOFF	No	Yes
US/UK Char Set	Yes (SCS) *	Yes
Auto Wrap	Yes (DECAWM)	Yes
Line Feed/New Line	Yes (LNM)	Yes
Local Echo	Yes (SRM)	Yes
Print Termination Character	Yes (DECPFF)	Yes
Printer Extent	Yes (DECPEX)	Yes
1 or 2 Stop Bits	No	Yes
Receive Parity	No	Yes
Break Enable	No	Yes
Disconnect Character Enable	No	Yes
Disconnect Delay	No	Yes
Auto answerback Enable	No	Yes
Initial Direction	No	Yes
Auto Turnaround	No	Yes
Power	No	Yes
WPS Terminal	No	Yes
Clock	No	Yes
Modem Data/Parity Bits	No	Yes
Transmit Speed	No	Yes
Receive Speed	No	Yes
Modem Control	No	Yes
Turnaround(End of Transmission)/Disconnect Character	Yes (DECTTC) *	Yes
Printer Data/Parity Bits	No	Yes
Transmit/Receive Speed	No	Yes

Table 6-4 SET-UP Features and Modes (Cont)

SET-UP Feature or Mode	Changed from Computer	Changed from Keyboard in SET-UP
Edit mode	Yes (DECEDM)	Yes
Edit Key Execution mode	Yes (DECEKEM)	Yes
Guarded Area Transfer mode	Yes (GATM)	Yes
Space Compression/Field Delimiter mode	Yes (DECSCFDM)	Yes
Line Transmit mode	Yes (DECLTM)	Yes
Transmit Termination mode	Yes (TTM)	Yes
Transmit Execution mode	Yes (DECTEM)	Yes
Bold Protect	Yes (DECPRO)	Yes
Underline Protect	Yes (DECPRO)	Yes
Blink Protect	Yes (DECPRO)	Yes
Reverse Video protect	Yes (DECPRO)	Yes
Normal Protect	Yes (DECPRO)	Yes
Erasure Mode	Yes (ERM)	Yes
End of line Character Enable		Yes
End of Line Character		Yes
Alternate keypad mode/ Numeric keypad mode	Yes (DECKPAM/DECKPNM) *	No
Cursor key mode	Yes (DECCKM) *	No
Origin mode	Yes (DECOM)	No
Insertion-replacement mode	Yes (IRM)	No
Keyboard Action mode	Yes (KAM)	No

* These features are not changed using the Set mode (SM) and Reset mode (RM) sequences.

NOTE: Ps is used to indicate a variable selective parameter. Each parameter in the sequence indicates a mode. The parameter is transmitted to the computer using ASCII characters. When setting several modes using a single SM or RM sequence, the parameters are separated by the semicolon (; , octal 073) character. *** is used to indicate one or more ASCII characters in the octal representation of the sequence.

Name	Mnemonic	Sequence	Definition
Reset mode	RM	ESC [Ps ;...; Ps l 033 133 *** 073 073 *** 154	Resets one or more modes as specified by each selective parameter (Ps) in the parameter string.
Set mode	SM	ESC [Ps ;...; Ps h 033 133 *** 073 073 *** 150	Sets one or more modes as specified by each selective parameter (Ps) in the parameter string.

Table 6-5 lists the ANSI specified modes and their selective parameters (Ps). Table 6-6 lists the ANSI compatible private modes and their selective parameters. Each mode is explained in detail later in this chapter. In the detail explanation of each mode, the set and reset mode sequences are repeated for each individual mode.

NOTE: When changing ANSI compatible private mode parameters (listed in Table 6-6), the first character in the parameter string is the question mark (? , octal 077) character. All parameters contained in the sequence are interpreted as ANSI compatible private parameters.

The following example shows the use of the question mark (used with ANSI private parameters) and the semicolon (used with multiple parameters) characters.

```
ESC [ ? 3 ; 4 h
033 133 077 063 073 064 150
```

The modes listed in Table 6-7 are specified in ANSI X3.64-1979 and are permanently set, permanently reset, or not applicable. Refer to the ANSI X3.64-1979 standard for more information about these modes.

ANSI/VT52 Compatibility

The VT131 terminal is compatible with both ANSI standards and private DIGITAL standards. Therefore, new software which meets both the ANSI standards and existing software designed for previous terminals (such as the VT52) can be used.

Table 6-5 ANSI Specified Modes

Name	Mnemonic	Parameter (Ps)
Error (ignored)		0
Guarded Area Transfer	GATM	1
Keyboard Action	KAM	2
Insertion-replacement	IRM	4
Erasure	ERM	6
Send-Receive	SRM	12
Transfer Termination	TTM	16
Linefeed/ New Line mode	LNM	20

Table 6-6 ANSI Compatible Private Modes

Name	Mnemonic	Parameter (Ps)
Error (ignored)		0
Cursor key	DECCKM	1
ANSI/VT52	DECANM	2
Column	DECCOLM	3
Scroll	DECSCLM	4
Screen	DECSCNM	5
Origin	DECOM	6
Auto Wrap	DECAWM	7
Auto Repeat	DECARM	8
Editing	DECEDM	10
Line Transmit	DECLTM	11
Space Compression/Field Delimiter	DECSCFDM	13
Transmit Execution	DECTEM	14
Edit Key Execution	DECEKEM	16
Printer Form Feed	DECPFF	18
Printer Extent	DECPEX	19

NOTE: The alternate keypad and numeric keypad modes are selected using dedicated sequences. The set and reset mode sequences are not used to select these modes. Refer to the Keypad Character Selection section of this chapter for more information about these sequences.

Table 6-7 Permanently Selected Modes

Name	Mnemonic	Selection	Function
Control representation	CRM	Reset	Control functions are performed without displaying a character to represent the control function received.
Editing boundary	EBM	Reset	Characters moved outside the margins are lost and erasing and cursor positioning functions are not performed outside the margins. This does not affect the Horizontal and Vertical Position (HVP) and Cursor Position (CUP) sequences.
Format effector action	FEAM	Reset	Control functions that effect the screen display are performed immediately.
Format effector transfer	FETM	N/A	
Horizontal editing	HEM	Reset	A character insertion causes the characters after the cursor to be shifted forward. A character deletion causes the characters after the cursor to be shifted backward.
Multiple area transfer	MATM	N/A	
Positioning unit	PUM	Reset	Horizontal and vertical positioning parameters in control functions are specified in units of character position.
Selected area transfer	SATM	N/A	

Table 6-7 Permanently Selected Modes (Cont)

Name	Mnemonic	Selection	Function
Status reporting transfer	SRTM	Reset	Status reports are transmitted by the VT102 using the Device Status Report (DSR) sequence.
Tabulation stop	TSM	Reset	The tab stop selections apply to the corresponding column of all lines on the screen.
Vertical editing	VEM	N/A	

The ANSI compatible sequences meet ANSI standards X3.64-1979 and X3.41-1974. VT131 terminal ANSI compatibility is selected using the ANSI/VT52 mode (DECANM) sequence in VT52 mode. Refer to the VT52 compatible sequence section of this chapter for details on selecting ANSI sequence compatibility. When the terminal is in ANSI mode, the following sequence selects compatibility with private DIGITAL sequences (VT52 mode).

NOTE: Features and modes selected while in ANSI mode are also used by the terminal when in VT52 mode. However, when VT52 mode is selected these features and modes can not be changed.

Name	Mnemonic	Sequence	Function
VT52 mode	DECANM	ESC [? 2 1 033 133 077 062 154	Reset selects private DIGITAL sequence compatibility while in ANSI mode. In VT52 mode the terminal responds to private DIGITAL sequences like a VT52 terminal.

Scrolling

Scrolling is the upward or downward movement of existing lines of characters on the screen. Scrolling is performed to make room for more lines of characters to be added to either the top or bottom of the scrolling region. Scrolling can be performed in two ways: jump scroll or smooth scroll. Select the type of scrolling using the following sequences.

NOTE: The auto XON/XOFF SET-UP feature can be used to ensure that received characters are not lost when using smooth scroll. If XON/XOFF control characters are not used, fill characters are needed.

Name	Mnemonic	Sequence	Function
Scroll mode	DECSCLM	ESC [? 4 h 033 133 077 064 150	Set selects smooth scrolling. Smooth scrolling causes lines to be added to the screen at 6 lines per second (60 Hz) or 5 lines per second (50 Hz).
Scroll mode	DECSCLM	ESC [? 4 1 033 133 077 064 154	Reset selects jump scrolling. Jump scroll allows lines of characters to be added to the screen as fast as possible.

Scrolling Region

The scrolling region is the area of the screen between the top and bottom margins. The top and bottom margins determine which lines on the screen are moved during scrolling. The minimum size of the scrolling region is two lines. Therefore, the line number of the top margin must be less than the line number of the bottom margin. Select the top and bottom margins of the scrolling region using the following sequence.

NOTE: Power up or reset causes the scrolling region to be the complete screen. When the margins are selected, the cursor moves to the origin (home position). The origin (home) position is determined by the origin mode (DECOM) feature selection.

NOTE: The Pt and Pb characters represent variable numeric parameters. The numeric parameters are decimal numbers transmitted to the terminal as ASCII characters. The *** character represents one or more variable numeric parameters in the octal presentation of the sequence.

Name	Mnemonic Sequence	Function
Set Top and Bottom Margins	DECSTBM ESC [Pt ; Pb r Ø33 133 *** Ø73 *** 162	Selects the top and bottom margins, defining the scrolling region. Pt is the line number of the first line in the scrolling region; Pb is the line number of the bottom line in the scrolling region. If Pt and Pb are not selected, the complete screen is used (no margins).

Origin (Home Position)

Origin mode determines the home position on the screen. If the location of the home position is within the scrolling region, the cursor cannot be moved outside of the top and bottom margins. If the home position is the upper left hand corner of the screen (the first character position of the screen), the cursor can be moved outside the top and bottom margins with the cursor position (CUP) and horizontal and vertical position (HVP) sequences.

The lines of the screen are numbered. The numbering of the lines is determined by the location of the origin. The origin (home position) is always line #1, column #1. Select the origin mode using the following sequences.

NOTE: The cursor is moved to the new origin position whenever the origin mode selection is changed. Power up or reset causes origin mode to be reset.

Name	Mnemonic	Sequence	Function
Origin mode	DECOM	ESC [? 6 h 033 133 077 066 150	Set selects the origin to be line #1, column #1 in the scrolling region. The line numbers are relative to the start of the scrolling region. The cursor cannot be moved outside of the scrolling region.
Origin mode	DECOM	ESC [? 6 1 033 133 077 066 154	Reset selects the origin to be the upper-left corner of screen (absolute). Line numbers are independent of the scrolling region. The cursor may be moved outside the scrolling region using the cursor position (CUP) or horizontal and vertical position (HVP) sequences.

Cursor Positioning

The cursor indicates the location of the active position. This is where the next character is displayed. The cursor position moves:

- ^ one column to the right when a character is displayed.
- ^ one line down when a line feed (LF, octal 012), form feed (FF, octal 014) or vertical tab (VT, octal 013) is received. (Line Feed/New Line may cause the cursor to also move to the left margin.)
- ^ to the left margin when a carriage return (CR, octal 015) is received.
- ^ one column to the left when a backspace (BS, octal 010) is received.
- ^ to the next tab stop or right margin if no tabs are set and a horizontal tab character (HT, octal 011) is received. When erasure mode (ERM) is reset and edit mode (DECEDM) is selected, the cursor moves to the next tab stop or protected field.
- ^ to the origin (home position) when the top and bottom margins of the scrolling region (DECSTBM) or the origin mode (DECOM) selection is changed.

The cursor is also moved using the following sequences.

NOTE: The Pn character is used to indicate a variable numeric parameter. The numeric parameter is a decimal number transmitted to the terminal using ASCII characters. If no parameter or a parameter of 0 is selected, the terminal assumes the parameter equals 1. The *** character represents one or more characters in the octal representation of the character.

Name	Mnemonic	Sequence	Function
Cursor Up	CUU	ESC [Pn A 033 133 *** 101	Moves the cursor Pn lines up in the same column. The cursor stops at the top margin.
Cursor Down	CUD	ESC [Pn B 033 133 *** 102	Moves the cursor down Pn lines in the same column. The cursor stops at the bottom margin.
Cursor Forward	CUF	ESC [Pn C 033 133 *** 103	Moves the cursor Pn columns to the right. The cursor stops at the right margin.
Cursor Backward	CUB	ESC [Pn D 033 133 *** 104	Moves the cursor Pn columns to the left. The cursor stops at the left margin.

NOTE: The Pl and Pc characters are used to indicate the numeric parameters within the sequence. The numeric parameter is a decimal number that represents one or more characters transmitted to the terminal as ASCII characters. The *** character represents the variable numeric parameter in the octal representation of the sequence.

Cursor Position	CUP	ESC [Pl ; Pc H 033 133 *** 073 *** 110	Moves the cursor to line Pl, column Pc. If either Pl or Pc are not selected or selected as 0, the cursor moves to the first line or column, respectively. Home position, the numbering of lines and ability to move the cursor into the margins depends on the origin mode (DECOM) selection.
-----------------	-----	--	---

NOTE: The cursor position (CUP) sequence operates the same as the horizontal and vertical position (HVP) sequence.

Cursor Position (Home)	CUP	ESC [H 033 133 110	The cursor moves to home position. Home position depends on the origin mode (DECOM) selection.
Horizontal and Vertical Position	HVP	ESC [P1 ; Pc f 033 133 *** 073 *** 146	Moves the cursor to line P1, column Pc. If either P1 or Pc are not selected or selected as 0, the cursor moves to the first line or column, respectively. Home position, the numbering of lines and ability to move the cursor into the margins depends on the origin mode (DECOM) selection.

NOTE: The cursor position (CUP) sequence operates the same as the horizontal and vertical position (HVP) sequence.

Horizontal and Vertical Position (Home)	HVP	ESC [f 033 133 146	The cursor moves to the home position. Home position depends on the origin mode (DECOM) selection.
Index	IND	ESC D 033 104	Moves the cursor down one line in the same column. If the cursor is at the bottom margin, a scroll up is performed.
Reverse Index	RI	ESC M 033 115	Moves the cursor up one line in the same column. If the cursor is at the top margin, a scroll down is performed.
Next Line	NEL	ESC E 033 105	Moves cursor to the first position on the next line. If the cursor is at the bottom margin, a scroll up is performed.
Save Cursor	DECSC	ESC 7 033 067	Saves the cursor position, character attribute (graphic rendition), and character set (G0, G1, G2 or G3) and origin mode (DECOM) selection in the terminal. (See Restore Cursor).

Restore DECRC ESC 8
 Cursor 033 070

Restores the previously saved cursor position, character attribute (graphic rendition), character set and origin mode (DECOM) selection. If none was saved the cursor moves to the origin (home position).

Columns Per Line
 Column mode selects the number of columns in a display line to be either 80 or 132 columns per line. With either 80 or 132 columns per line selected, the screen can display 24 lines of characters. Select the number of columns per line using the following sequences.

NOTE: When changing between 80 and 132 columns per line, the screen is erased and the scrolling region is selected for full screen (24 lines). Therefore, the top margin is the first line on the screen and the bottom margin of the scrolling region is line 24.

Name	Mnemonic Sequence	Function
Column mode DECCOLM	ESC [? 3 h 033 133 077 063 150	Set selects 132 columns per line.
Column mode DECCOLM	ESC [? 3 1 033 133 077 063 154	Reset selects 80 columns per line.

Auto Wrap
 Auto wrap mode selects the position where the next character is placed when the cursor is at the right margin. Select the auto wrap feature using the following sequences.

NOTE: Regardless of the selection of the auto wrap feature, the tab character never moves the cursor to the next line.

Name	Mnemonic Sequence	Function
Auto Wrap mode	DECAWM ESC [? 7 h 033 133 077 067 150	Set turns the auto wrap feature on. Any displayable characters received when the cursor is at the right margin are displayed on the next line. The display scrolls up if the cursor is at the end of the scrolling region and the cursor is not positioned outside the margins.

Auto Wrap DECAWM ESC [? 7 1
mode 033 133 077 067 154

Reset turns the auto wrap feature off. Any displayable characters received replace any previous character displayed at the right margin.

Screen Background
Screen mode selects either light or dark display background used on the screen. Select the screen background using the following sequences.

Name	Mnemonic	Sequence	Function
Screen mode	DECSCNM	ESC [? 5 h 033 133 077 065 150	Set selects reverse screen, a white screen background with black characters.
Screen mode	DECSCNM	ESC [? 5 1 033 133 077 065 154	Reset selects normal screen, a black screen background with white characters.

Line Feed/New Line
Line feed/new line mode selects the control characters transmitted by the RETURN key. Also, this feature determines the action taken by the terminal when receiving the carriage return (CR, octal 015), line feed (LF, octal 012), form feed (FF, octal 014) and vertical tab (VT, octal 013) control characters. Table 6-8 provides a summary of the line feed/new line mode feature. Select the line feed/new line feature using the following sequences.

NOTE: When half duplex communication with coded control is selected, the carriage return character can also be used as a turnaround character. Refer to Chapter 7 for more information about half duplex communication.

Name	Mnemonic	Sequence	Function
Line Feed/ New Line mode	LNLM	ESC [2 0 h 033 133 062 060 150	Set causes a received line feed, form feed or vertical tab character to move the cursor to the first column of next line. The RETURN key transmits both a carriage return and line feed. This selection is also called "the new line option".

Table 6-8 Line Feed/New Line Feature

Line Feed/New Line Feature Selection	Key Pressed	Character Transmitted
OFF	RETURN	Carriage Return (CR)
OFF	LINE FEED	Line Feed (LF)
ON	RETURN	Carriage Return - Line Feed (CR LF)
ON	LINE FEED	Line Feed (LF)

Line Feed/New Line Feature Selection	Character Received	Function
OFF	CR	Carriage Return (cursor moves to left margin)
OFF	LF, FF, VT	Line feed (cursor moves to the next line but stays in same column)
ON	CR	Carriage Return (cursor moves to left margin)
ON	LF, FF, VT	Carriage Return -- Line feed (cursor moves to left margin of the next line)

Line Feed/
New Line
mode

ESC [2 0 1
033 133 062 060 154

Reset causes a received line feed, form feed or vertical tab character to move the cursor to the next line in the current column. The RETURN key transmits a carriage return.

Keyboard Action (FDX)

This feature is only used during full duplex communication, it does not operate when half duplex communication is selected. Keyboard action mode allows the computer to turn the keyboard on and off. This feature is always reset when SET-UP is entered. Select keyboard action mode using the following sequences.

Name	Mnemonic	Sequence	Function
Keyboard Action mode	KAM	ESC [2 h 033 133 062 150	Set turns off the keyboard and turns on the KBD LOCKED indicator.
Keyboard Action mode	KAM	ESC [2 1 033 133 062 154	Reset turns on the keyboard and turns off the KBD LOCKED indicator.

Auto Repeat

Auto repeat mode selects automatic key repeating. Automatic key repeating causes a key pressed for more than one-half second to automatically repeat the transmission of the character at a rate of 30 characters per second. Key repeating does not affect the following keys: SET-UP, ESC, RETURN, ENTER, NO SCROLL, and CTRL key. When reset no keys automatically repeat. Select auto repeat mode using the following sequences.

Name	Mnemonic	Sequence	Function
Auto Repeat mode	DECARM	ESC [? 8 h 033 133 077 070 150	Set selects the auto repeat feature. A key pressed for more than one-half second automatically repeats.
Auto Repeat mode	DECARM	ESC [? 8 1 033 133 077 070 154	Reset selects no auto repeat feature. The keys do not automatically repeat.

Local Echo (keyboard send-receive)

Send-receive mode determines if the terminal preforms local echo. Local echo causes every character transmitted by the terminal to be automatically displayed on the screen. Therefore, the computer does not have to transmit (echo) the character back to the terminal for display. When local echo is not selected, characters are only transmitted to the computer, the computer must echo the characters back to the terminal for display. Select send-receive mode using the following sequences.

Name	Mnemonic	Sequence	Function
Send - Receive mode	SRM	ESC [1 2 h 033 133 061 062 150	Set turns off the local echo feature. Characters are transmitted only to the computer, the computer must echo characters for display on the screen.
Send - Receive mode	SRM	ESC [1 2 1 033 133 061 062 154	Reset turns on the local echo feature. Characters transmitted to the computer are automatically displayed on the screen.

Cursor Key Character Selection

When alternate (application) keypad mode (DECKPAM) is selected, cursor key mode selects the set of characters transmitted by the cursor keys. When numeric keypad mode (DECKPNM) is selected, cursor key mode is reset and can not be changed. Refer to Table 6-9 for the codes transmitted by the cursor keys. Select cursor key mode using the following sequences.

NOTE: Power up or reset causes cursor key mode to be reset. Also, in all communication except full duplex no modem control (FDX A), this mode is reset during a communication line connection. Refer to Chapter 7 for more information about communication.

Name	Mnemonic	Sequence	Function
Cursor Key mode	DECCKM	ESC [? 1 h 033 133 077 061 150	Set selects cursor keys to generate control (application) functions.
Cursor Key mode	DECCKM	ESC [? 1 1 033 133 077 061 154	Reset selects cursor keys to generate ANSI cursor control sequences.

Table 6-9 ANSI Cursor Control Key Codes

Cursor Key (arrow)	Cursor Key Mode Reset	Cursor Key Mode Set
Up	ESC [A 033 133 101	ESC O A 033 117 101
Down	ESC [B 033 133 102	ESC O B 033 117 102
Right	ESC [C 033 133 103	ESC O C 033 117 103
Left	ESC [D 033 133 104	ESC O D 033 117 104

Keypad Character Selection

The auxiliary keypad can be used to generate either numeric characters or control functions. The type of characters selected is determined by the selection of either alternate or numeric keypad mode. The characters generated by the cursor keys are also affected by the keypad mode selection. Refer to the Cursor Key Character Selection section of this chapter for more information about the cursor keys. The program function (PF) keys of the auxiliary keypad generate the same character sequences regardless of the keypad character selection. Refer to Table 6-10 for the characters generated by these keys. Select the type of characters generated by the auxiliary keypad keys using the following sequences.

NOTE: Power up or reset causes numeric keypad mode to be selected. Numeric keypad mode is also selected during communication line connections, except when using full duplex no modem control (FDX A). Refer to Chapter 7 for more information about communication line connects.

Name	Mnemonic Sequence	Function
Alternate (Application) Keypad mode	DECKPAM ESC = 033 075	Selects alternate (application) keypad mode. The auxiliary keypad generates control functions and the type of characters generated by the cursor keys is selected by cursor key mode (DECKKM).
Numeric Keypad mode	DECKPNM ESC > 033 076	Selects numeric keypad mode. The auxiliary keypad generates characters which correspond to the numeric, comma, period and minus sign keys of the main keyboard. The cursor keys generate only ANSI cursor control sequences.

Character Sets and Selection

The VT131 terminal can display up to 254 different characters. Of these 254 characters, the terminal holds 127 displayable characters within the basic read only memory (ROM) of the terminal. The remaining 127 displayable characters can be added by installing an alternate character set ROM.

The terminal can select only 94 characters (one character set) at a time. Therefore, the characters displayed by the terminal are held in five character sets, with some characters appearing in more than one character set. The VT131 terminal can display the

Table 6-10 ANSI Keypad Codes

Key	Numeric Keypad Mode	Alternate Keypad Mode
0	0 060	ESC O p 033 117 160
1	1 061	ESC O q 033 117 161
2	2 062	ESC O r 033 117 162
3	3 063	ESC O s 033 117 163
4	4 064	ESC O t 033 117 164
5	5 065	ESC O u 033 117 165
6	6 066	ESC O v 033 117 166
7	7 067	ESC O w 033 117 167
8	8 070	ESC O x 033 117 170
9	9 071	ESC O y 033 117 171
-(minus)	-(minus) 055	ESC O m 033 117 155
,(comma)	,(comma) 054	ESC O l 033 117 154
.(period)	.(period) 056	ESC O n 033 117 156
ENTER*	CR CR LF 015 or 015 012	ESC O M 033 117 115
PF1	ESC O P 033 117 120	ESC O P 033 117 120
PF2	ESC O Q 033 117 121	ESC O Q 033 117 121

Table 6-10 ANSI Keypad Codes (Cont)

Key	Numeric Keypad Mode	Alternate Keypad Mode
PF3	ESC O R Ø33 117 122	ESC O R Ø33 117 122
PF4	ESC O S Ø33 117 123	ESC O S Ø33 117 123

* When numeric keypad mode is select, the ENTER key generates the same characters as the RETURN key. The RETURN key character code can be changed by the line feed/new line feature. When off, this feature causes the key to generate a single control character (CR, octal Ø15). When on, this feature causes the key to generate two characters (CR, octal Ø15 and LF, octal Ø12).

NOTE: In ANSI mode, if the codes are echoed back to the terminal, or if the terminal is off-line, the last character of the sequence is displayed on the screen; for example, PF4 is displayed as a "S".

following character sets.

United States character set

United Kingdom character set

Special characters and line drawing character set (VT100 compatible)

Alternate ROM character set

Alternate ROM Special Character character set

NOTE: The United States and United Kingdom character sets meet the "ISO international register of character sets to be used with escape sequences".

Tables 6-11 through 6-13 show the character sets. Notice that the control characters and the space and delete characters are the same in all character sets.

Any two of the character sets can be considered active at any one time. The two active character sets are designated by the computer as G0 and G1 using the select character set (SCS) sequence. Once the character sets are designated by the computer, a single control character is used to switch between the active character sets. The shift in (SI, octal 017) control character invokes the G0 character set. The shift out (SO, octal 016) control character invokes the G1 character set.

The designated character sets are active until another select character set (SCS) sequence is received. The G0 and G1 character sets can be designated by the computer as often as needed using the SCS sequence. The following sequences designate the G0 character set.

NOTE: In all communication except full duplex no modem control (FDX A), the character set selected in SET-UP is used after a communication line connection. Refer to Chapter 7 for more information about communication.

Name	Mnemonic	Sequence	Function
Select Character Set	SCS	ESC (A 033 050 101	Designate the United Kingdom character set as G0.
Select Character Set	SCS	ESC (B 033 050 102	Designate the United States character set as G0.
Select Character Set	SCS	ESC (0 033 050 060	Designate the special character and line drawing character set as G0.

BITS					0 0		0 0 1		0 1 0		0 1 1		1 0 0		1 0 1		1 1 0		1 1 1				
COLUMN					0		1		2		3		4		5		6		7				
B7	B6	B5	B4	B3	B2	B1	ROW																
0	0	0	0	0	0	0	0	NUL	0 0 0		20 16 10	SP	40 32 20	0	60 48 30	@	100 64 40	P	120 80 50	'	140 96 60	p	160 112 70
0	0	0	1	1	1	1	1		1 1 1	DC1 (XON)	21 17 11	!	41 33 21	1	61 49 31	A	101 65 41	Q	121 81 51	a	141 97 61	q	161 113 71
0	0	1	0	1	0	1	2		2 2 2		22 18 12	"	42 34 22	2	62 50 32	B	102 66 42	R	122 82 52	b	142 98 62	r	162 114 72
0	0	1	1	1	1	1	3		3 3 3	DC3 (XOFF)	23 19 13	£	43 35 23	3	63 51 33	C	103 67 43	S	123 83 53	c	143 99 63	s	163 115 73
0	1	0	0	1	0	1	4		4 4 4		24 20 14	\$	44 36 24	4	64 52 34	D	104 68 44	T	124 84 54	d	144 100 64	t	164 116 74
0	1	0	1	1	1	1	5	ENQ	5 5 5		25 21 15	%	45 37 25	5	65 53 35	E	105 69 45	U	125 85 55	e	145 101 65	u	165 117 75
0	1	1	0	1	0	1	6		6 6 6		26 22 16	&	46 38 26	6	66 54 36	F	106 70 46	V	126 86 56	f	146 102 66	v	166 118 76
0	1	1	1	1	1	1	7	BEL	7 7 7		27 23 17	,	47 39 27	7	67 55 37	G	107 71 47	W	127 87 57	g	147 103 67	w	167 119 77
1	0	0	0	1	0	1	8	BS	8 8 8	CAN	30 24 18	(50 40 28	8	70 56 38	H	110 72 48	X	130 88 58	h	150 104 68	x	170 120 78
1	0	0	1	1	0	1	9	HT	9 9 9		31 25 19)	51 41 29	9	71 57 39	I	111 73 49	Y	131 89 59	i	151 105 69	y	171 121 79
1	0	1	0	1	0	1	10	LF	10 A	SUB	32 26 1A	*	52 42 2A	:	72 58 3A	J	112 74 4A	Z	132 90 5A	j	152 106 6A	z	172 122 7A
1	0	1	1	1	0	1	11	VT	11 B	ESC	33 27 1B	+	53 43 2B	;	73 59 3B	K	113 75 4B	[133 91 5B	k	153 107 6B	{	173 123 7B
1	1	0	0	1	0	1	12	FF	12 C		34 28 1C	,	54 44 2C	<	74 60 3C	L	114 76 4C	\	134 92 5C	l	154 108 6C		174 124 7C
1	1	0	1	1	0	1	13	CR	13 D		35 29 1D	-	55 45 2D	=	75 61 3D	M	115 77 4D]	135 93 5D	m	155 109 6D	}	175 125 7D
1	1	1	0	1	0	1	14	SO	14 E		36 30 1E	.	56 46 2E	>	76 62 3E	N	116 78 4E	^	136 94 5E	n	156 110 6E	~	176 126 7E
1	1	1	1	1	1	1	15	SI	15 F		37 31 1F	/	57 47 2F	?	77 63 3F	O	117 79 4F	_	137 95 5F	o	157 111 6F	DEL	177 127 7F

KEY

ASCII CHARACTER	ESC	33	OCTAL
		27	DECIMAL
		1B	HEX

MA-7248

Table 6-11 United Kingdom Character Set

BITS		0 0 0		0 0 1		0 1 0		0 1 1		1 0 0		1 0 1		1 1 0		1 1 1	
B7 B6 B5		0		1		2		3		4		5		6		7	
B4 B3 B2 B1		0		1		2		3		4		5		6		7	
ROW		0		1		2		3		4		5		6		7	
0 0 0 0	0	NUL	000		201610	SP	403220	0	604830	@	1006440	P	1208050	'	1409660	p	16011270
0 0 0 1	1		111	DC1 (XON)	211711	!	413321	1	614931	A	1016541	Q	1218151	a	1419761	q	16111371
0 0 1 0	2		222		221812	"	423422	2	625032	B	1026642	R	1228252	b	1429862	r	16211472
0 0 1 1	3		333	DC3 (XOFF)	231913	#	433523	3	635133	C	1036743	S	1238353	c	1439963	s	16311573
0 1 0 0	4		444		242014	\$	443624	4	645234	D	1046844	T	1248454	d	14410064	t	16411674
0 1 0 1	5	ENQ	555		252115	%	453725	5	655335	E	1056945	U	1258555	e	14510165	u	16511775
0 1 1 0	6		666		262216	&	463826	6	665436	F	1067046	V	1268656	f	14610266	v	16611876
0 1 1 1	7	BEL	777		272317	'	473927	7	675537	G	1077147	W	1278757	g	14710367	w	16711977
1 0 0 0	8	BS	1088	CAN	302418	(504028	8	705638	H	1107248	X	1308858	h	15010468	x	17012078
1 0 0 1	9	HT	1199		312519)	514129	9	715739	I	1117349	Y	1318959	i	15110569	y	17112179
1 0 1 0	10	LF	1210A	SUB	32261A	*	52422A	:	72583A	J	112744A	Z	132905A	j	1521066A	z	1721227A
1 0 1 1	11	VT	1311B	ESC	33271B	+	53432B	;	73593B	K	113754B	[133915B	k	1531076B	{	1731237B
1 1 0 0	12	FF	1412C		34281C	,	54442C	<	74603C	L	114764C	\	134925C	l	1541086C		1741247C
1 1 0 1	13	CR	1513D		35291D	-	55452D	=	75613D	M	115774D]	135935D	m	1551096D	}	1751257D
1 1 1 0	14	SO	1614E		36301E	.	56462E	>	76623E	N	116784E	^	136945E	n	1561106E	~	1761267E
1 1 1 1	15	SI	1715F		37311F	/	57472F	?	77633F	O	117794F	_	137955F	o	1571116F	DEL	1771277F

KEY

ASCII CHARACTER	ESC	33	OCTAL
		27	DECIMAL
		1B	HEX

MA-7247

Table 6-12 United States Character Set

BITS		0 0		0 0 1		0 1 0		0 1 1		1 0 0		1 0 1		1 1 0		1 1 1	
B7 B6 B5		COLUMN															
B4 B3 B2 B1	ROW	0		1		2		3		4		5		6		7	
0 0 0 0	0	NUL	0 0 0		20 16 10	SP	40 32 20	0	60 48 30	@	100 64 40	P	120 80 50	↑	140 96 60	-	160 112 70
0 0 0 1	1		1 1 1	DC1 (XON)	21 17 11	!	41 33 21	1	61 49 31	A	101 65 41	Q	121 81 51	≡	141 97 61	-	161 113 71
0 0 1 0	2		2 2 2		22 18 12	"	42 34 22	2	62 50 32	B	102 66 42	R	122 82 52	⋈	142 98 62	-	162 114 72
0 0 1 1	3		3 3 3	DC3 (XOFF)	23 19 13	#	43 35 23	3	63 51 33	C	103 67 43	S	123 83 53	ƒ	143 99 63	-	163 115 73
0 1 0 0	4		4 4 4		24 20 14	\$	44 36 24	4	64 52 34	D	104 68 44	T	124 84 54	⋈	144 100 64	†	164 116 74
0 1 0 1	5	ENQ	5 5 5		25 21 15	%	45 37 25	5	65 53 35	E	105 69 45	U	125 85 55	ƒ	145 101 65	†	165 117 75
0 1 1 0	6		6 6 6		26 22 16	&	46 38 26	6	66 54 36	F	106 70 46	V	126 86 56	0	146 102 66	‡	166 118 76
0 1 1 1	7	BEL	7 7 7		27 23 17	'	47 39 27	7	67 55 37	G	107 71 47	W	127 87 57	±	147 103 67	‡	167 119 77
1 0 0 0	8	BS	10 8 8	CAN	30 24 18	(50 40 28	8	70 56 38	H	110 72 48	X	130 88 58	⋈	150 104 68	‡	170 120 78
1 0 0 1	9	HT	11 9 9		31 25 19)	51 41 29	9	71 57 39	I	111 73 49	Y	131 89 59	ƒ	151 105 69	‡	171 121 79
1 0 1 0	10	LF	12 10 A	SUB	32 26 1A	*	52 42 2A	:	72 58 3A	J	112 74 4A	Z	132 90 5A	‡	152 106 6A	‡	172 122 7A
1 0 1 1	11	VT	13 11 B	ESC	33 27 1B	+	53 43 2B	;	73 59 3B	K	113 75 4B	[133 91 5B	‡	153 107 6B	‡	173 123 7B
1 1 0 0	12	FF	14 12 C		34 28 1C	,	54 44 2C	<	74 60 3C	L	114 76 4C	\	134 92 5C	‡	154 108 6C	‡	174 124 7C
1 1 0 1	13	CR	15 13 D		35 29 1D	-	55 45 2D	=	75 61 3D	M	115 77 4D]	135 93 5D	‡	155 109 6D	‡	175 125 7D
1 1 1 0	14	SO	16 14 E		36 30 1E	.	56 46 2E	>	76 62 3E	N	116 78 4E	^	136 94 5E	‡	156 110 6E	.	176 126 7E
1 1 1 1	15	SI	17 15 F		37 31 1F	/	57 47 2F	?	77 63 3F	O	117 79 4F	(BLANK)	137 95 5F	-	157 111 6F	DEL	177 127 7F

KEY

ASCII CHARACTER

ESC	33
	27
	1B

OCTAL
DECIMAL
HEX

MA-7249

Table 6-13 Special Character and Line Drawing Character Set

Select Character Set SCS ESC (1
 033 050 061

Designate the alternate ROM character set as G0.

Select Character Set SCS ESC (2
 033 050 062

Designate the alternate ROM special characters character set as G0.

The following sequences designate the G1 character set.

Name	Mnemonic	Sequence	Function
Select Character Set	SCS	ESC) A 033 051 101	Designate the United Kingdom character set as G1.
Select Character Set	SCS	ESC) B 033 051 102	Designate the United States character set as G1.
Select Character Set	SCS	ESC) 0 033 051 060	Designate the special character and line drawing character set as G1.
Select Character Set	SCS	ESC) 1 033 051 061	Designate the alternate ROM character set as G1.
Select Character Set	SCS	ESC) 2 033 051 062	Designate the alternate ROM special characters character set as G1.

The VT131 terminal also has a G2 and G3 character set. However, these character sets are always the character set selected in SET-UP. The G2 and G3 character sets can be selected for only one character at a time. The G2 and G3 character sets are selected using the single shift 2 (SS2) and single shift 3 (SS3) sequences. The terminal returns to the previously used character set after a single character is displayed. Select the G2 and G3 character sets for one character using the following sequences.

Name	Mnemonic	Sequence	Function
Single Shift 2	SS2	ESC N 033 115	Selects the G2 character set for one character. The G2 character set is the character set selected in SET-UP.
Single Shift 3	SS3	ESC O 033 117	Selects the G3 character set for one character. The G3 character set is the character set selected in SET-UP.

The VT131 terminal can transmit characters displayed on the screen to either the computer (in edit mode) or the printer (using the media copy printing commands). When transmitting a block of characters to either the computer or optional printer, the VT131 terminal attempts to select the correct character set. The following rules are used when the terminal transmits characters from more than one character set.

NOTE: If the printer does not use ANSI sequences or the printer does not use multiple character sets, the use of multiple character sets cause incorrect characters to be printed.

1. When starting a character transmission to either the computer or printer, the G0 character set of the VT131 terminal is assumed to be the same as the receiving device (computer or printer).
2. If at any time during the transmission, the next character to be transmitted is not from the presently selected G0 character set, the G0 character set is changed. A G0 designator is transmitted by the VT131 terminal to select the proper character set. The G1 character set is never changed.
3. If at the end of transmission, the G0 character set of the receiving device (computer or printer) is different from when the transmission started, the G0 character set is changed. A G0 designator is transmitted to select the G0 character set selected at the beginning of the transmission. The G0 designator is transmitted before the printer termination (to the printer) or end of block (to the computer) character.

Before transmitting characters, the VT131 terminal must determine which character set has the character to be transmitted. If the character is not in the currently selected G0 character set, the character sets are searched as follows:

The order in which the character sets are searched is:

- a) U.S./U.K. character set selected in SET-UP
- b) U.S. character set
- c) U.K. character set
- d) Special characters and line drawing character set
- e) Alternate ROM character set
- f) Alternate ROM special characters character set

NOTE: The Substitute character can be displayed on the screen as a result of receiving a parity error, the SUB or CAN control characters or the D (octal 141) character with the special character and line drawing character set selected. The substitute character is always transmitted by the terminal as a SUB (octal 032) character.

Character Attributes

The VT131 terminal can display character attributes that change the character display without changing the actual character. Contiguous characters with the same character attribute are referred to as a field. Field boundaries are determined by a change in character attribute(s). The character attributes of the terminal are:

- ^ bold (increased intensity)
- ^ underline
- ^ blink
- ^ reverse video (character background opposite of the screen background SET-UP feature)
- ^ any combination of the attributes

One or more character attributes can be selected at one time. Therefore, selection of an attribute does not turn off other attributes already selected. When the character attribute is selected, all characters received by the terminal are displayed with the attribute. If the characters are moved on the screen (by scrolling), the attributes move with the characters. Select the character attributes using the following sequences.

Name	Mnemonic	Sequence	Function
Select Graphic Rendition	SGR	ESC [m 033 133 155	No character attribute selected. All attributes off.
Select Graphic Rendition	SGR	ESC [0 m 033 133 060 155	No character attribute selected. All attributes off.
Select Graphic Rendition	SGR	ESC [1 m 033 133 061 155	Bold (increased intensity) character attribute selected.
Select Graphic Rendition	SGR	ESC [4 m 033 133 064 155	Underline character attribute selected.
Select Graphic Rendition	SGR	ESC [5 m 033 133 065 155	Blink character attribute selected.

Select SGR ESC [7 m Reverse video character
 Graphic 033 133 067 155 attribute selected.
 Rendition

Tab Stops

Tab stops are positions selected on the horizontal lines of the screen. The cursor advances (tabs) to the tab stops when the terminal receives a horizontal tab (HT, octal 011) control character. If no tab stops are set, the horizontal tab character moves the cursor to the right margin. Set and clear the tab stops using the following sequences.

Name	Mnemonic	Sequence	Function
Horizontal Tabulation Set	HTS	ESC H 033 110	Set one horizontal tab stop at the cursor position.
Tabulation Clear	TBC	ESC [g 033 133 147	Clear the horizontal tab stop at the cursor position.
Tabulation Clear	TBC	ESC [0 g 033 133 060 147	Clear the horizontal tab stop at the cursor position.
Tabulation Clear	TBC	ESC [3 g 033 133 063 147	Clear all horizontal tab stops.

Line Attributes

Line attributes are display features that affect a complete line of the display. The cursor selects the line affected by the attribute. The cursor does not change its character position when the line attribute is changed. However, if the cursor would be move past the right margin by the line attribute, the cursor stops at the margin. When lines are moved on the screen (by scrolling), the line attribute is moved with the line. Select line attributes using the following sequences.

NOTE: If an entire line is erased using the erase in display (ED) sequence, the line attribute is changed to single height and single width.

Name	Mnemonic	Sequence	Function
Double Height Line	DECDHL	Top Half: ESC # 3 033 043 063	Causes the line with the cursor to become the top or bottom half of a double-height double-width line. The sequences must be used in pairs on adjacent lines and the
		Bottom Half: ESC # 4 033 043 064	

Erase In Line	EL	ESC [1 K 033 133 061 113	Erases from the beginning of the line to the cursor, including the cursor position.
Erase In Line	EL	ESC [2 K 033 133 062 113	Erases all of the line.
Erase In Display	ED	ESC [J 033 133 112	Erases from the cursor to the end of the screen, including the cursor position.
Erase In Display	ED	ESC [0 J 033 133 060 112	Erases from the cursor to the end of the screen, including the cursor position.
Erase In Display	ED	ESC [1 J 033 133 061 112	Erases from beginning of the screen to the cursor, including the cursor position.
Erase In Display	ED	ESC [2 J 033 133 062 112	Erases all of the display -- all lines are erased, changed to single-width, and the cursor does not move.

Computer Editing

The editing commands allow the computer to insert or delete characters and lines of characters on the screen at the cursor position. The cursor position is not changed when inserting or deleting lines on the screen. Delete characters or insert and delete lines using the following sequences.

NOTE: Insertion-replacement mode (IRM) selects how characters are added to the screen. Refer to the Insertion-Replacement section of the chapter for more information about the insertion or replacement of characters.

NOTE: When in edit mode (DECEDM), erasure mode (ERM) determines if protected characters can be edited using the delete character (DCH), insert line (IL) and delete line (DL) sequences. Refer to the Erasure Mode section of this chapter to select erasure mode.

Same	Mnemonic	Sequence	Function
Delete Character	DCH	ESC [Pn P 033 133 *** 120	Deletes Pn characters starting with the character at the cursor position. When a character is deleted from the

screen, all characters to the right of the cursor move to the left. A space is created at the right margin, this space character has no character attribute. The characters moved when using this sequence are bounded by the end of the line or protected field (when in edit mode and erasure mode is reset). The delete character sequence is ignored when the cursor is in a protected field while erasure mode is reset.

Insert Line IL

ESC [Pn L
Ø33 133 *** 114

Inserts Pn lines at the line with the cursor. Lines on the screen below the cursor are moved down. Lines moved past the bottom margin are lost. When in edit mode and erasure mode is reset, characters moved into a line with a protected field are also lost. This sequence has no effect when received with the cursor outside the scrolling region.

Delete Line DL

ESC [Pn M
Ø33 133 *** 115

Deletes Pn lines starting at the line with the cursor. As lines are deleted from the screen, the lines displayed below the cursor move up. A line is added to the bottom of the screen or the next line with a protected field (when in edit mode and erasure mode is reset). The lines added have spaces with no line or character attributes. This sequence has no effect when received with the cursor outside the scrolling region.

Character Insertion-Replacement

Characters received by the terminal are displayed at the cursor position. Insertion and replacement mode determines how characters are added to the screen. Characters are added to the screen by either replacing the character, or displaying the character and moving the previously displayed character to the right. Select insertion-replacement mode using the following sequences.

NOTE: In all communication except full duplex no modem control (FDX A), this mode is reset during a communication line connection. Refer to Chapter 7 for more information about communication.

Name	Mnemonic Sequence	Function
Insertion - IRM replacement mode	ESC [4 h 033 133 064 150	Set selects insertion mode and turns the INSERT keyboard indicator on. Insertion mode allows characters to be added to a line without erasing the previously displayed characters. The characters previously displayed on the line move to the right. Characters moved into the right margin are lost.
Insertion - IRM replacement mode	ESC [4 l 033 133 064 154	Reset selects replacement mode and turns the INSERT keyboard indicator off. New characters displayed on the line replace the previously displayed character at the cursor position. The character previously at the cursor position is erased and the new character is displayed.

Local Editing (Edit mode)

The editing mode sequence determines if the terminal operates as an interactive (interactive mode) or local editing (edit mode) terminal. In interactive mode, the terminal transmits typed characters to the computer immediately. In edit mode, the terminal places typed characters into screen memory for display and local editing. The characters are edited and then transmitted to the computer.

Edit mode only affects the transmission of characters to the computer, characters received from the computer are processed as received. While in edit mode, characters received from the computer and characters received from the keyboard are both

displayed on the screen. When the computer is displaying characters, keyboard action mode (KAM) can be used to turn on and off the terminal keyboard.

Select interactive or edit mode using the followins sequences.

Name	Mnemonic	Sequence	Function
Editing mode	DECEDM	ESC [? 1 0 h 033 133 077 061 060 150	Set selects edit mode. The EDIT keyboard indicator is on when the terminal is in edit mode.
Editing mode	DECEDM	ESC [? 1 0 1 033 133 077 061 060 154	Reset selects interactive mode. The EDIT keyboard indicator is off when the terminal is in interactive mode.

Edit Key Execution

Edit and interactive mode can be selected from the terminal keyboard. Edit key execution mode determines how the SHIFT and EDIT keys select interactive and edit modes. Select edit key execution mode using the following sequences.

Name	Mnemonic	Sequence	Function
Edit Key Execution mode	DECEKEM	ESC [? 1 6 h 033 133 077 061 066 150	Set selects immediate response to the SHIFT and EDIT key sequence. The key sequence causes the terminal to immediately switch between interactive and edit modes.
Edit Key Execution mode	DECEKEM	ESC [? 1 6 1 033 133 077 061 066 154	Reset selects deferred response to the SHIFT and EDIT key sequence. The key sequence causes the terminal to transmit an edit mode (DECEDM) sequence. The DECEDM sequence is a request to the computer to switch the terminal between the interactive and edit modes. The computer echos the DECEDM sequence to change the selection.

Character Protection

The terminal can display characters with character attributes. These attributes are selected by the select graphic rendition

(SGR) sequence. In edit mode, character attributes can be used to create protected or unprotected characters and fields (group of characters). Protected characters can not be changed, overwritten, erased or moved by keyboard entries. A protection attribute changes the way characters with the specified attribute are edited and transmitted. The selection of protection attribute does not change any attributes of the characters displayed on the screen or on characters received. Select the protection attributes using the following sequences.

NOTE: Characters outside the scrolling region are considered protected characters because editing can not be performed outside the scrolling region. The characters outside the scrolling region are not transmitted during block transmissions of characters.

Name	Mnemonic	Sequence	Function
Protected Field Attributes	DECPRO	ESC [0] 033 133 060 175	Selects no protection attributes.
Protected Field Attributes	DECPRO	ESC [1] 033 133 061 165	Selects bold protection.
Protected Field Attributes	DECPRO	ESC [4] 033 133 064 175	Selects underline protection.
Protected Field Attributes	DECPRO	ESC [5] 033 133 065 175	Selects blink protection.
Protected Field Attributes	DECPRO	ESC [7] 033 133 067 175	Selects reverse video protection.
Protected Field Attributes	DECPRO	ESC [2 5 4] 033 133 062 065 064 175	Selects all attributes off protection.

Erasure Mode

Erasure mode determines if protected characters can be erased by the computer in edit mode. The computer erases characters with the erase in line (EL) and erase in display (ED) sequences. Select erasure mode using the following sequences.

NOTE: Erasure mode affects the delete character (DCH), delete line (DL) and insert line (IL) sequences. Refer to the Computer Editing section of this chapter for more information about the affects of erasure mode on these sequences. Also, the horizontal tab (HT) control character is affected. Refer to the Control Character section of this chapter for more information about the affects of erasure mode on the horizontal tab character.

Name	Mnemonic	Sequence	Function
Erasure mode	ERM	ESC [6 h 033 133 066 150	Set allows all characters on the screen to be erased by the erased line (EL) and erase in display (ED) sequences regardless of character protection.
Erasure mode	ERM	ESC [6 1 033 133 066 154	Reset permits only unprotected characters to be erased. The erase in line (EL) and erase in display (ED) sequences do not erase protected characters.

Characters received from the computer can not be displayed in protected character positions. If the computer attempts to display a character into a protected character position, the cursor is moved to the next unprotected character position and the character is displayed. If there are no more unprotected characters in the scrolling region, the cursor is moved to the end of the scrolling region and the character is ignored.

Transmit Execution

In edit mode, characters are placed in screen memory for display and local editing. When editing is complete, the characters are transmitted to the computer as a block of characters. The ENTER key (or RETURN key in DECLTM) is pressed to start the transmission of characters. Transmit execution mode determines if the character block transmission is immediate or deferred. When immediate is selected, transmission begins when the key is pressed. When deferred is selected, transmission begins after the computer enables transmission. Select transmit execution mode using the following sequence.

Name	Mnemonic	Sequence	Function
Transmit Execution	DECTEM	ESC [? 1 4 h 033 133 077 061 064 150	Set selects immediate transmission of

characters. Transmission begins when the **ENTER** key is pressed (or **RETURN** key if **DECLTM** is set).

Transmit Execution DECTEM ESC [? 1 4 1
 033 133 077 061 064 154

Reset selects deferred transmission of characters. Pressing the **ENTER** key causes the terminal to transmit the set transmit state (STS). The STS sequence informs the computer that the terminal wants to transmit characters. Transmission is deferred and no further transmission occurs from the terminal until the terminal receives the transmit (DECMIT) sequence from the computer.

Transmission Request

In edit mode, the set transmit state (STS) sequence requests the computer to enable transmission within the terminal. Transmission is deferred and the terminal transmits nothing until it receives the transmit (DECMIT) sequence from the computer.

NOTE: The set transmit state (STS) sequence is only transmitted when transmit execution mode (DECTEM) is reset.

Name	Mnemonic	Sequence	Function
Set Transmit State	STS	ESC S 033 123	Transmitted to the computer to request a character block transmission.

Transmission Enable

In edit mode, the transmit (DECMIT) sequence is transmitted by the computer to enable a block mode transmission from the terminal. The transmit (DECMIT) sequence requests is usually used in response to the set transmit state (STS) sequence. The STS sequence is transmitted by the terminal when transmit execution mode (DECTEM) is reset and the **ENTER** key (or **RETURN** key in **DECLTM**) is pressed. However, DECMIT can be used regardless of the DECTEM selection. To request a character block transmission use the following sequence.

Name	Mnemonic	Sequence	Function
Transmit mode	DECMIT	ESC 5 033 065	Causes the terminal to transmit characters.

Line Transmit

In edit mode, a block of characters is transmitted in one of three block sizes. The block sizes are line, partial page and full page. Line transmit mode (DECLTM) and transmit termination mode (TTM) determine the size of the character blocks transmitted by the terminal. Line transmit mode determines if the edited characters are transmitted a line at a time or by the page. The size of the page transmitted is determined by the transmit termination mode (TTM) selection. Select line transmit mode using the following sequences.

NOTE: In line transmit mode, either the ENTER or RETURN keys are used to start a character block transmission. Transmit execution mode (DECTEM) determines if the transmission is immediate or deferred.

Name	Mnemonic	Sequence	Function
Line Transmit	DECLTM	ESC [? 1 1 h 033 133 077 061 061 150	Set selects line transmit mode. While in edit mode, characters are transmitted by line. The terminal transmits the characters of the line with the cursor. During a line transmission, the cursor moves to the first unprotected field on the line. If line feed/new line (LNM) is set, the cursor moves to the first unprotected field in the next line. If the cursor is at the end of the scrolling region, the cursor moves to the first unprotected field of the current line.
Line Transmit	DECLTM	ESC [? 1 1 1 033 133 066 061 061 154	Reset selects full page or partial page transfer as determined by the transfer termination mode (TTM) selection.

Transfer Termination

In edit mode, transfer termination mode (TTM) operates when line transmit mode (DECLTM) is reset. Transfer termination mode determines if the terminal transmits a full or partial page during the block mode character transmission. Select either full page or partial page transmission using the following sequences.

Name	Mnemonic	Sequence	Function
Transfer Termination mode	TTM	ESC [1 6 h 033 133 061 066 150	Set selects full page transmission. The complete scrolling region is transmitted (full page).
Transfer Termination mode	TTM	ESC [1 6 1 033 133 061 066 154	Reset selects partial page transmission. A partial page is the area of the screen between the partial page marker and the cursor. The partial page marker is a marker in the display memory that is not displayed on the screen. If the partial page transmit marker is not present or the cursor is before the marker, the starting point is the beginning of the scrolling region.

Space Compression/Field Delimiter

In edit mode, space compression/field delimiter mode (DECSCFDM) determines if space characters (SP, octal 040) at the end of a field are transmitted. When the spaces are not transmitted, the end of each field is indicated by a record separator character (RS, octal 36). Select space compression/field delimiter mode using the following sequences.

Name	Mnemonic	Sequence	Function
Space Compression/Field Delimiter mode	DECSCFDM	ESC [? 1 3 h 033 133 077 061 063 150	Set selects space compression/field delimiting. Trailing spaces of fields are not transmitted. All fields transmitted end with a single record separator character except the last field on a line. The last field ends with an end of line character (selected by the line feed/new line mode (LNM) feature).
Space Compression/Field Delimiter mode	DECSCFDM	ESC [? 1 3 1 033 133 077 061 063 154	Reset selects no space compression/field delimiting. Characters are transmitted as displayed on the screen.

Guarded Area Transmit

In edit mode, guarded area transmit mode (GATM) determines if protected fields are transmitted to the computer or replaced with a record separator (RS, octal 36) character. This mode also determines if the protected fields are printed as displayed on the screen or replaced with space characters. Select guarded area transfer mode using the following sequences.

Name	Mnemonic	Sequence	Function
Guarded Area Transfer mode	GATM	ESC [1 h 033 133 061 150	Set selects the transmission of all characters regardless of protection attribute.
Guarded Area Transfer mode	GATM	ESC [1 1 033 133 061 154	Reset selects the transmission of only unprotected character fields. When transmitting to the computer, the protected fields are replaced by the record separator character. When transmitting to the printer, the protected fields are replaced by space characters.

Transmit Termination Character (end of block)

In edit mode, a control character can be selected to indicate the end of a transmitted character block. The character is transmitted at the end of each character block transmitted to the computer. Select the end of block character using the following sequences.

NOTE: This sequence is ignored when half duplex coded control (HDX B) is selected.

Name	Mnemonic	Sequence	Function
Transmit Termination Character	DECTTC	ESC [0 033 133 060 174	Selects no end of block character (function disabled).
Transmit Termination Character	DECTTC	ESC [1 033 133 061 174	Selects a Form Feed (FF, octal 014) as the end of block character.
Transmit Termination Character	DECTTC	ESC [2 033 133 062 174	Selects a End of Text (ETX, octal 003) as the end of block character.
Transmit Termination Character	DECTTC	ESC [3 033 133 063 174	Selects a End of transmission (EOT, octal 004) as the end of block

character.

Transmit DECTTC ESC [4 |
Termination 033 133 064 174
Character

Selects a Carriage Return (CR, octal 015) as the end of block character.

Printing

The VT131 terminal has a serial printer interface to allow local printing. All print operations can be selected using sequences. Two of the print operations can be selected from the VT131 keyboard (auto print and print screen).

When printing characters from the screen of the terminal, the tab stops of the terminal and printer are ignored. Characters printed are spaced using the space (SP, octal 040) character.

If a line contains double height characters, the characters are printed as two identical lines of standard width characters. Double width characters are printed as standard width characters on a single line.

Before selecting a print operation, check the printer status using the printer status report (DSR) in ANSI mode. Do not select a print operation if the serial printer is not ready to print. Select print operations using the following sequences.

Name	Mnemonic Sequence	Function
------	-------------------	----------

NOTE: Auto print operation can be turned on or off at any time however, auto-printing is not performed in edit mode.

Media Copy MC (Auto Print on)	ESC [? 5 i 033 133 077 065 151
-------------------------------------	------------------------------------

Turns on the auto print operation. A line on the screen is printed when the cursor is moved to the next line. The cursor is moved off the line by a line feed (LF, octal 012), form feed (FF, octal 014) or vertical tab (VT, octal 013) control character. During an auto wrap the line is also printed, the line is ended with CR, LF. The control character used to move the cursor to the next line is also transmitted to the printer.

Media Copy MC (Auto Print off)	ESC [? 4 i 033 133 077 064 151
--------------------------------------	------------------------------------

Turns off the auto print operation.

NOTE: Printer controller has a higher priority than auto print operation. Therefore, printer controller can be selected and characters printed while auto print is on.

Media Copy MC
(Printer
Controller
on)

ESC [5 i
Ø33 133 Ø65 151

Turns on printer controller operation. All characters received by the terminal are printed by the serial printer without being displayed on the screen. The VT131 does not insert or delete spaces, provide line delimiters or select the proper character sets in the printer.

Media Copy MC
(Printer
Controller off)

ESC [4 i
Ø33 133 Ø64 151

Turns off printer controller operation. The printhead should always be moved to the left margin before leaving printer controller.

Media Copy MC
(Print
Cursor Line)

ESC [? 1 i
Ø33 133 Ø77 Ø61 151

Causes the serial printer to print the line on the screen with the cursor. The cursor position is not changed. The print cursor line operation ends when the line is printed.

Media Copy MC
(Print
Screen)

ESC [i
Ø33 133 151

Causes the serial printer to print the contents of the screen. Depending on the print extent (DECPEX) sequence, either the complete screen is printed or just the scrolling region. The scrolling region is selected using the set top and bottom margins (DECSTBM) sequence. The print screen operation ends when the screen is printed.

Media Copy MC
(Print
Screen)

ESC [Ø i
Ø33 133 Ø6Ø 151

Causes the serial printer to print the contents of the screen. Depending on the print extent (DECPEX) sequence, either the complete screen is printed or just the scrolling

region. The scrolling region is selected using the set top and bottom margins (DECSTBM) sequence. The print screen operation ends when the screen is printed.

Printer Extent

Printer extent mode determines if the complete screen or just the scrolling region is printed during a print screen operation. Select printer extent mode using the following sequences.

NOTE: Guarded area transfer mode (GATM) determines if protected fields are printed as displayed on the screen or replaced with space (SP, octal 040) characters.

Name	Mnemonic	Sequence	Function
Printer extent mode	DECPEX	ESC [? 1 9 h 033 133 077 061 071 150	Set selects the entire screen to be printed during a print screen operation.
Printer extent mode	DECPEX	ESC [? 1 9 1 033 133 077 061 071 154	Reset selects only the scrolling region to be printed during a print screen operation.

Print Termination Character

A print termination character can be transmitted to the optional serial printer at the end of each print screen operation. Printer form feed mode determines if a print termination character is transmitted. The form feed (FF, octal 014) control character is used as the print termination character. Select printer form feed mode using the following sequence.

Name	Mnemonic	Sequence	Function
Printer form feed mode	DECPFF	ESC [? 1 8 h 033 133 077 061 070 150	Set selects the form feed character as the print termination character. The print termination character is transmitted to the printer at the end of each print screen operation.
Printer form feed mode	DECPFF	ESC [? 1 8 1 033 133 077 061 070 154	Reset selects no print termination character.

Reports

Reports are transmitted by the terminal in response to requests

from the computer. Reports are used to determine the type of terminal, the operational status of the terminal and the cursor position. The report requests and responses are as follows.

NOTE: The VT131 terminal does not respond to the DSR, DA or DECID sequences during printer controller operation.

Name	Mnemonic	Sequence	Function
Device Status Report (computer)	DSR	ESC [5 n 033 133 065 156	The computer requests a status report (using a DSR sequence).
Device Status Report (terminal)	DSR	ESC [0 n 033 133 060 156	Response from terminal -- Ready, no malfunctions detected.
Device Status Report (terminal)	DSR	ESC [3 n 033 133 063 156	Response from terminal -- Malfunction error found in self-test.
Device Status Report (computer)	DSR	ESC [? 1 5 n 033 133 077 061 065 156	Computer requests for a printer status report. The VT131 checks the status of the optional serial printer. This report should be requested before any print operation is selected.
Device Status Report (printer)	DSR	ESC [? 1 3 n 033 133 077 061 063 156	No printer is connected to the VT131 terminal. The Data Terminal Ready (DTR) signal of the printer has not been on since the VT131 was powered up.
Device Status Report (printer)	DSR	ESC [? 1 1 n 033 133 077 061 060 156	The printer is not ready to print. DTR of the printer was on since the VT131 was powered up, but DTR is now off.
Device Status Report (printer)	DSR	ESC [? 1 0 n 033 133 077 061 060 156	The printer is ready to print. DTR from the printer is on.
Device Status	DSR	ESC [6 n 033 133 066 156	Request for a cursor position report from the

top and bottom margins (scrolling region) are selected for the complete screen.

Name	Mnemonic	Sequence	Function
Reset To Initial State	RIS	ESC c 033 143	Reset the terminal to its initial state.

Tests and Adjustments

All of these test and adjustments are performed locally using the DECTST and DECALN sequences. The terminal uses self-tests to be sure the terminal is operating correct. The tests provide error codes on the keyboard indicators or screen to indicate failures. Refer to Chapter 10 for more information about the self tests and displayed error codes. Also, a screen alignment pattern is provided to adjust the screen display.

The DECTST sequences cause the terminal to disconnect from the communication line and erase both the input and keyboard character buffers. Select terminal self-test using the following sequences.

NOTE: Test results are shown on the keyboard and screen. The test result (pass or fail) is reported to the computer using the device status report (DSR) sequence.

Name	Mnemonic	Sequence	Function
Invoke Confidence Test	DECTST	ESC [2 ; 1 y 033 133 062 073 061 171	Power Up test -- terminal resets and performs power up test.
Invoke Confidence Test	DECTST	ESC [2 ; 2 y 033 133 062 073 062 171	Data Loop Back test. Uses test connector on the modem interface connector.
Invoke Confidence Test	DECTST	ESC [2 ; 4 y 033 133 062 073 064 171	EIA loop back test. Uses test connector on the modem interface connector.
Invoke Confidence Test	DECTST	ESC [2 ; 1 6 y 033 133 062 073 061 066 171	Printer loop back test. Uses test connector on the printer interface connector.
Invoke Confidence Test	DECTST	ESC [2 ; 9 y 033 133 062 073 071 171	Repeat power up test continuously until failure or power off.
Invoke Confidence Test	DECTST	ESC [2 ; 1 0 y 033 133 062 073 061 060 171	Repeat data loopback test continuously until failure or power off. Uses test connector on the modem interface connector.

Invoke Confidence Test	DECTST	ESC [2 ; 1 2 y 033 133 062 073 061 062 171	Repeat EIA loopback test continuously until failure or power off. Uses test connector on the modem interface connector.
Invoke Confidence Test	DECTST	ESC [2 ; 2 4 y 033 133 062 073 062 064 171	Repeat printer loop back test continuously until failure. Uses test connector on the printer interface.
Screen Alignment Display	DECALN	ESC # 8 033 043 070	This command fills the complete screen area with uppercase E's for screen focus and alignment. This command is used by DEC manufacturing and Field Service personnel.

VT52 COMPATIBLE SEQUENCES

The VT52 compatible sequences meet private DIGITAL standards. Therefore, the VT131 terminal can use existing software designed for previous terminals (such as the VT52). VT52 compatibility is selected from the keyboard in SET-UP (refer to Chapter 2) or by the computer using a sequence (refer to the ANSI Compatible Sequences section of this chapter).

Mode Selection

While in VT52 mode, most of the features of the terminal can not be selected using sequences. However, the following three modes can be selected using sequences:

ANSI mode

Alternate Keypad mode on

Alternate Keypad mode off (Numeric mode selected)

ANSI/VT52 Compatibility

The VT131 terminal is an upward and downward software compatible terminal. The terminal is compatible with both ANSI standard and private DIGITAL standards. Therefore, new software which meets the ANSI standards and existing software designed for previous terminals (such as the VT52) can be used. The ANSI compatible sequences meet standards X3.64-1979 and X3.41-1974. The features of the terminal selected in ANSI mode are also used while in VT52 mode. However, these features usually can not be changed in VT52 mode. Therefore, ANSI mode must be used to select most of the VT131 features. Select ANSI compatibility using the following sequence.

Name	Mnemonic Sequence	Function
ANSI mode	DECANM ESC < 033 074	All sequences are interpreted according to ANSI Standards X3.64-1979 and X3.41-1974. The VT52 escape sequence described in this section are not recognized.

Keypad Character Selection

The auxiliary keypad can be used to generate either numeric characters or control functions. When the keypad is used to generate control functions, alternate (application) keypad mode is selected. When the keypad is used to generate numeric characters, exit alternate keypad mode (select numeric keypad mode). Refer to Table 6-14 for the characters generated by the keypad keys. Enter and exit alternate (application) keypad mode using the following sequences.

NOTE: Power up or reset causes the terminal to exit alternate keypad mode (select numeric keypad mode). Also, in all

Table 6-14 VT52 Keypad Codes

Key	Alternate Keypad Mode Off (Numeric Keypad Mode)	Alternate Keypad Mode On	
0	0 060	ESC ? p 033 077 160	
1	1 061	ESC ? q 033 077 161	
2	2 062	ESC ? r 033 077 162	
3	3 063	ESC ? s 033 077 163	
4	4 064	ESC ? t 033 077 164	
5	5 065	ESC ? u 033 077 165	
6	6 066	ESC ? v 033 077 166	
7	7 067	ESC ? w 033 077 167	
8	8 070	ESC ? x 033 077 170	
9	9 071	ESC ? y 033 077 171	
-(minus)	-(minus) 055	ESC ? m 033 077 155	**
,(comma)	,(comma) 054	ESC ? l 033 077 154	**
.(period)	.(period) 056	ESC ? n 033 077 156	
ENTER*	CR CR LF 015 or 015 012	ESC ? M 033 077 115	
PF1	ESC P 033 120	ESC P 033 120	
PF2	ESC Q 033 121	ESC Q 033 121	

Table 6-14 VT52 Keypad Codes (Cont)

Key	Alternate Keypad Mode Off (Numeric Keypad Mode)	Alternate Keypad Mode On
PF3	ESC R Ø33 122	ESC R Ø33 122
PF4	ESC S Ø33 123	ESC S Ø33 123 **

* When numeric keypad mode is select (alternate keypad mode is off), the ENTER key generates the same characters as the RETURN key. The RETURN key character code can be changed by the line feed/new line feature. When off, this feature causes the key to generate a single control character (CR, octal Ø15). When on, this feature causes the key to generate two characters (CR, octal Ø15 and LF, octal Ø12).

** These sequences are not generated by the VT52.

communication except full duplex no modem control (FDX A), numeric keypad mode is selected during a communication line connection. Refer to Chapter 7 for more information about communication.

Name	Sequence	Function
Enter Alternate Keypad Mode	ESC = 033 075	The auxiliary keypad keys generate sequences for use by the applications program.
Exit Alternate Keypad Mode (Numeric Mode)	ESC > 033 076	The auxiliary keypad keys generate characters that corresponding to the numeric, comma, period and minus sign keys of the main keyboard.

NOTE: In VT52 mode, the alternate and numeric keypad modes generate different characters than in ANSI mode.

Character Sets and Selection

While in VT52 mode, the terminal can use either the character set selected by the U.S./U.K. character set SET-UP feature or the Special Character and Line Drawing character set. Table 6-11 and 6-12 show the United Kingdom and United States character sets. Table 6-13 shows the Special Character and Line Drawing character set. The graphics mode characters in the VT131 terminal are different from those in the VT52 terminal. Table 6-15 compares the VT131 Special Character and Line Drawing character set to the VT52 Graphics mode (character set). Select the character sets using the following sequences.

NOTE: In all communication except full duplex no modem control (FDX A), the character set selected in SET-UP is used after a communication line connection. Refer to Chapter 6 for more information about communication.

Name	Sequence	Function
Enter Graphics mode	ESC F 033 106	Selects the Special Character and Line Drawing character set.
Exit Graphics mode	ESC G 033 107	Selects the character set selected in SET-UP.

Cursor Positioning

The cursor indicates the location of the active position. This is where the next character is displayed. The VT52 mode margins are the top and bottom margins selected in ANSI mode. If the margins are not selected in ANSI mode, the terminal uses the entire display screen. The cursor moves:

Table 6-15 Special Character and Line Drawing Set and Graphics Mode Comparison

Octal Code	US or UK Set	Special Character and Line Drawing Set	VT52 In Graphics Mode (Not available in VT131)
137		Blank	blank
140	∇	<>	reserved
141	a	Checkerboard (error indicator)	solid rectangle
142	b	ht	1/
143	c	ff	3/
144	d	cr	5/
145	e	lf	7/
146	f	°	degrees
147	g	+ -	plus or minus
150	h	nl	right arrow
151	i	vt	ellipsis (Dots)
152	j	└	divide by
153	k	┘	down arrow
154	l	┌	bar at scan 0
155	m	L	bar at scan 1
156	n	+	bar at scan 2
157	o	-	bar at scan 3
160	p	-	bar at scan 4
161	q	-	bar at scan 5
162	r	-	bar at scan 6
163	s	-	bar at scan 7
164	t	T-	subscript 0
165	u	-	subscript 1
166	v		subscript 2
167	w	T-	subscript 3
170	x		subscript 4
171	y	<=	subscript 5
172	z	=>	subscript 6
173	{	i-i	subscript 7
174		/=	subscript 8
175	}	L-	subscript 9
176	~	.	paragraph

- ^ one column to the right when a character is displayed.
- ^ one line down when a line feed (LF, octal 012), form feed (FF, octal 014) or vertical tab (VT, octal 013) is received. (Line feed/new line may cause the cursor to also move to the left margin.)
- ^ to the left margin when a carriage return (CR, octal 015) is received.
- ^ one column to the left when a backspace (BS, octal 010) is received.
- ^ to the next tab stop or right margin if no tabs are set and a horizontal tab character (HT, octal 011) is received. When erasure mode (ERM) is reset and edit mode (DECEDM) is selected, the cursor moves to the next tab stop or protected field.

The following sequences also move the cursor.

Name	Sequence	Function
Cursor Up	ESC A 033 101	Move the cursor up one line in same column. Cursor stops at the top of the screen.
Cursor Down	ESC B 033 102	Move the cursor down one line in same column. Cursor stops at the bottom of the screen.
Cursor Right	ESC C 033 103	Move the cursor one column to the right. Cursor stops at the right margin.
Cursor Left	ESC D 033 104	Move the cursor one column to the left. Cursor stops at the left margin.
Cursor to Home	ESC H 033 110	Move the cursor to the home position.
Direct Cursor Address	ESC Y line column 033 131 *** **	Move the cursor to the specified line and column. The line and column numbers are sent as the ASCII characters whose codes are the octal number plus octal 037. For example, line 1 column 8 parameters are octal 040 (first line) and octal 050

(eighth column).

Reverse Line Feed ESC I
 Ø33 111

Move the cursor up one line in the same column. If the cursor is at the top margin, a scroll down is performed.

Erasing

Erasing removes characters from the screen. When characters are erased from the screen, the characters are lost. Erase characters from the screen using the following sequences.

Name	Sequence	Function
Erase to End of Line	ESC K Ø33 113	Erase all characters from the cursor to the end of the current line, including the cursor position. The cursor does not move.
Erase to End of Screen	ESC J Ø33 112	Erase all characters from the cursor to the end of the screen, including the cursor position. The cursor does not move.

Printing

The VT131 terminal has a serial printer interface to allow local printing. All print operations can be selected using sequences. Two of the print operations can be selected from the VT131 keyboard (auto print and print screen).

When printing characters from the screen of the terminal, the tab stops of the terminal and printer are ignored. Characters printed are spaced using the space (SP, octal Ø40) character.

If a line has double height characters, the characters are printed as two identical lines of standard width characters. Double width characters are printed as standard width characters on a single line.

Before selecting a print operation, check the printer status using the printer status report (DSR) in ANSI mode. Determine if the serial printer is ready to print. Select print operations using the following sequences.

Name	Sequence	Function
------	----------	----------

NOTE: Auto print operation can be turned on or off at any time, however auto printing is not performed while in edit mode.

Auto Print ESC ^
 033 136

Turns on the auto print operation. A line on the screen is printed when the cursor is moved off the line. The cursor is moved off the line by a line feed (LF, octal 012), form feed (FF, octal 014) or vertical tab (VT, octal 013) control character or During an auto wrap the line is also printed, the line is ended with CR, LF. The control character used to move the cursor to the next line is also transmitted to the printer.

Auto Print ESC
 033 137

Turns off the auto print operation.

NOTE: Printer controller has a higher priority than the auto print operation. Therefore, printer controller can be selected and characters printed while auto print is on.

Print Controller ESC W
 033 127

Turns on printer controller operation. All characters received by the terminal are printed by the serial printer without being displayed on the screen. The VT131 does not insert or delete spaces, provide line delimiters or select the proper character set within the printer.

Print Controller ESC X
 033 130

Turns off printer controller operation. The printhead should be moved to the left margin before leaving printer controller.

Print Cursor Line ESC J
 033 135

Causes the serial printer to print the line on the screen with the cursor. The cursor position is not changed. The print cursor line operation ends when the line is printed.

Print
Screen

ESC V
Ø33 126

Causes the serial printer to print the screen. Depending on the print extent (DECPEX) sequence, either the full screen or just the scrolling region is printed. The scrolling region is selected using the DECSTBM sequence. The print screen operation ends when the screen is printed.

Reports

Reports are generated by the terminal in response to a request from the computer. The terminal generates only one report in VT52 mode. The following sequences are the request for a report and the response to the report request.

Identify

ESC Z
Ø33 132

This sequence causes the terminal to send an identify sequence to the computer.

Identify

ESC / Z
Ø33 Ø57 132

VT131 response to Identify.

GENERAL

This chapter describes how the VT131 terminal communicates with the computer and optional serial printer. The chapter is divided by the type of interface, modem or printer. A detailed description of each connector and its signals is provided. Also, this chapter describes the communication features used by the terminal.

NOTE: The 20 mA current loop interface option (VT1XX-CA) is described in Chapter 9.

CONNECTING TO THE COMPUTER

The VT131 terminal can be physically connected to a computer directly or through a common carrier facility (telephone line) as shown in Figure 7-1. In both applications, either the modem interface provided with the terminal or the VT1XX-CA 20 mA current loop interface option are used.

When connecting the terminal to the computer using a modem, three steps are needed:

- 1) Select a modem. The modem used by the terminal must be compatible with the modem used by the computer. Several types of modems can be used with the VT131 terminal. Table 7-1 lists the possible modem configurations used on public switched telephone lines. Table 7-2 lists the possible modem configurations used on dedicated telephone lines.
- 2) Select the communication SET-UP features. The SET-UP features must be selected to match the type of communication used with the computer. The communication features are described in the Modem Serial Characters, Break and Modem Control sections of this chapter. Refer to Chapter 4 for more information about the communication SET-UP features.
- 3) Select the internal communication switches of the terminal. Compare the interface information provided with the modem, to the interface information provided in the Modem Control section of this chapter. Determine which lines of the terminal are not used by the modem and disconnect these signals using the internal communication switches.

NOTE: These switch settings are usually not changed from the factory settings.

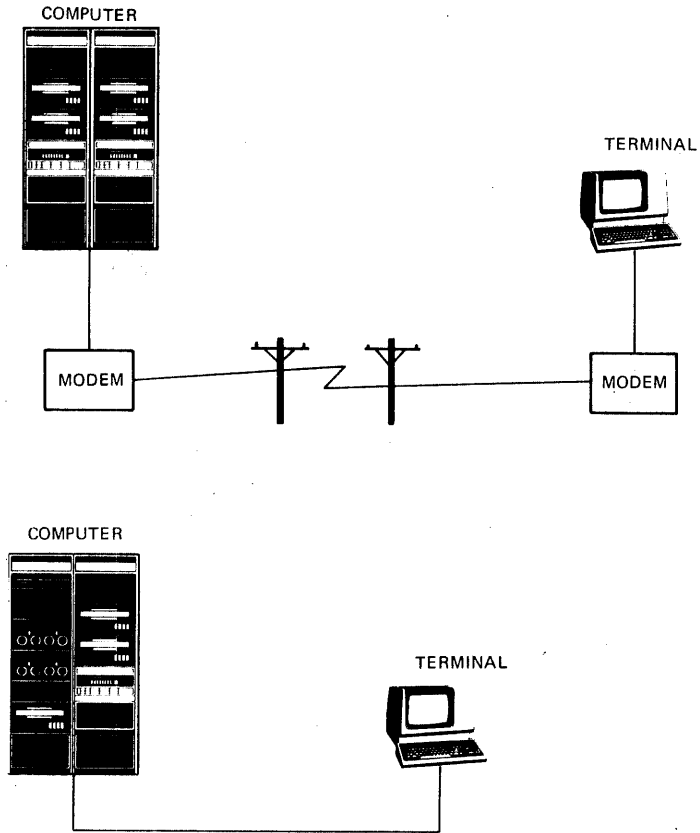

MA-7776A

Figure 7-1 Connecting to the Computer

Table 7-1 Possible Bell Modem Configurations (Public Switched)

NOTE: The modems listed below are examples of possible modem configurations. Equivalent modems supplied by other manufactures may also be used.

Communication Parameters	Manual Originate Only	Manual Answer Only	Manual Originate Answer	Auto Answer	Reverse Channel
300 baud Full duplex 2-wire	113A	113D	103A	103A	No
	113C		103J	103J	No
				113B	No
				113D	No
			212A	212A	No
1200 baud Half duplex 2-wire			202S	202S	Yes
			212A	212A	No
1200 baud Full duplex 2-wire					

Table 7-2 Possible Bell Modem Configurations (Dedicated Line)

NOTE: The modems listed below are examples of possible modem configurations. Equivalent modems supplied by other manufactures may also be used.

Communication Parameters	Modem	Line Conditioning	Reverse Channel
300 baud Full duplex 2-wire	103F	Unconditioned 3002 channel	No
1200 baud Half Duplex 2-wire	202T	With reverse channel, up to 1200 baud on unconditioned or C2 conditioned 3002 channel. Without reverse channel, up to 1200 baud on unconditioned 3002 channel and 1200 to 1800 baud on C2 conditioned channel.	Yes
1200 baud Full duplex 4-wire	202T	Without reverse channel, up to 1200 baud on unconditioned 3002 channel and 1200 to 1800 baud on C2 conditioned channel.	No

Modem (Communication) Interface

The VT131 terminal communicates with the computer using a modem interface. The interface connector is a DB-25 (EIA RS-232-C type) male connector mounted on the back of the terminal as shown in Figure 7-2. This interface meets Electronic Industry Association (EIA) standard RS-423, RS-232-C and International Telegraph and Telephone Consultive Committee (CCITT) recommendations V.24 and V.28.

Communication Switch Settings

The VT131 terminal has a set of ten communication switches mounted within the terminal. These ten switches allow some of the communication signals to be disconnected from the VT131 terminal modem connector. The switch pack must be configured to match the needs of the modem.

These switch settings are usually not changed from the factory settings listed in Table 7-3. However, when using some modems these switches must be configured. Figure 7-3 shows the communication signals which have switches.

Modem Serial Characters

The VT131 terminal communicates using serial characters. The serial character format used by the modem interface must be the same as the character format used by the computer. Serial characters are transmitted using a start bit, 7 or 8 data bits, an optional parity bit and one or two stop bits. Figure 7-4 shows an example of the serial character format used by the terminal.

The number of data bits per character and parity are selected using the modem data/parity bits SET-UP feature. If 8-bit characters are selected, the last data bit is forced to the space (Ø) condition and the eighth data bit is ignored when receiving characters. The data bits are transmitted with the least significant bit first. (Refer to ANSI X3.15-1976 for details on the serial character format.)

The parity bit is used to detect character transmission errors of both transmitted and received characters. The modem data/parity bits SET-UP feature selects the type of parity bit used when transmitting and receiving characters. If parity is not selected, the parity bit is removed from the serial character.

The receive parity SET-UP feature determines if the parity of received characters is checked or ignored. However, received character parity can only be checked for odd or even parity, mark and space parity cannot be checked on received characters.

Break Signal

A Break signal can be enabled or disabled using the break enable SET-UP feature. The Break signal is a space condition transmitted for 0.275 seconds + 10 percent. The computer response to the Break signal depends on the computer and software.

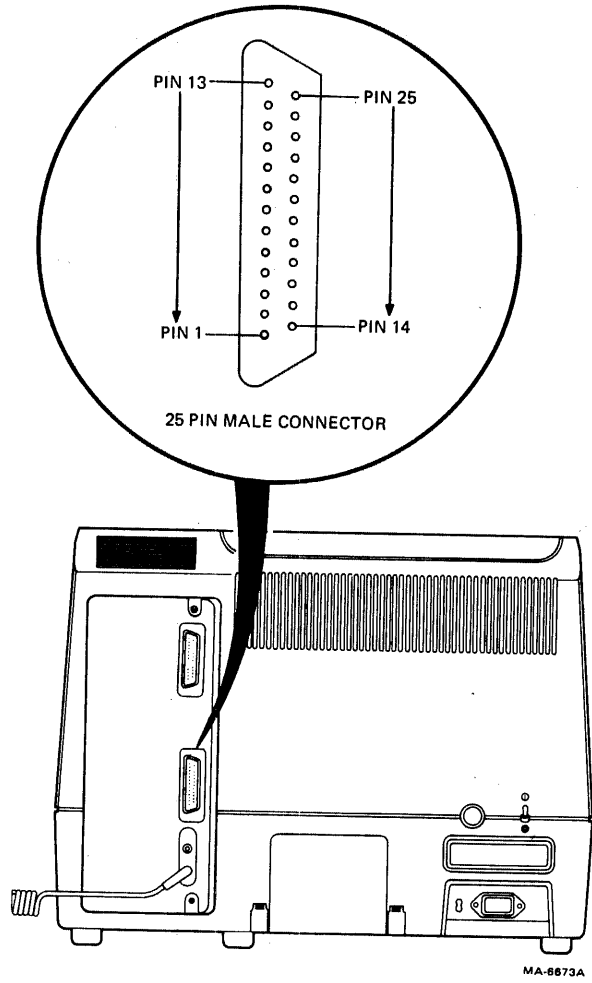
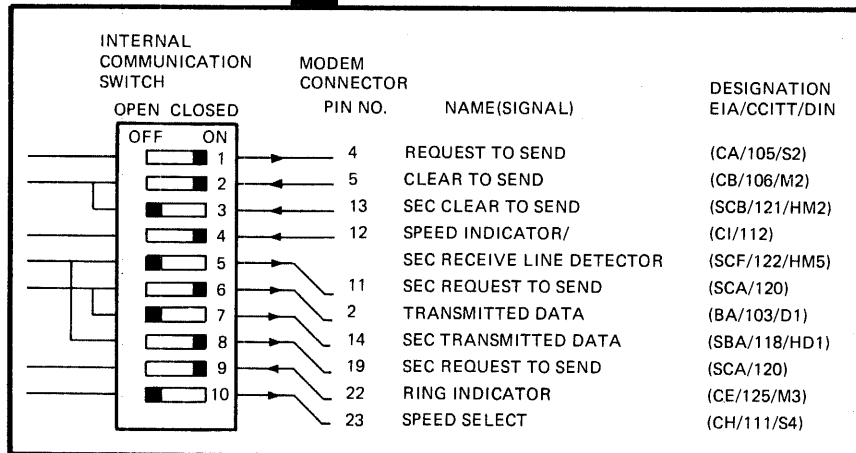
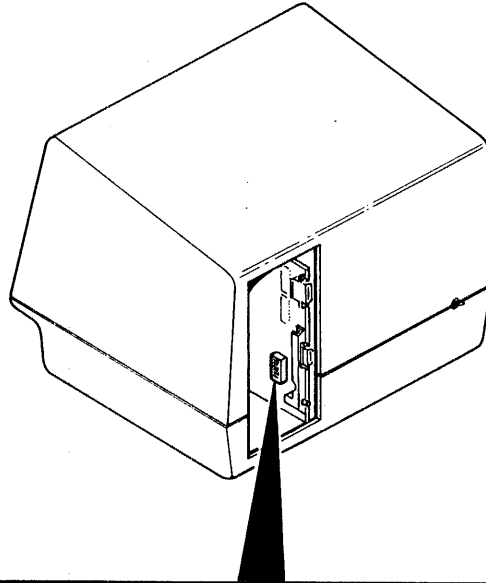

Figure 7-2 Modem Connector Location and Pin Numbering

Table 7-3 Factory Configured Communication Switch selections

Switch	Selection
S1	On (closed)
S2	On (closed)
S3	Off (open)
S4	On (closed)
S5	Off (open)
S6	On (closed)
S7	Off (open)
S8	On (closed)
S9	On (closed)
S10	Off (open)



MA-7256D

Figure 7-3 Communication Switch Summary

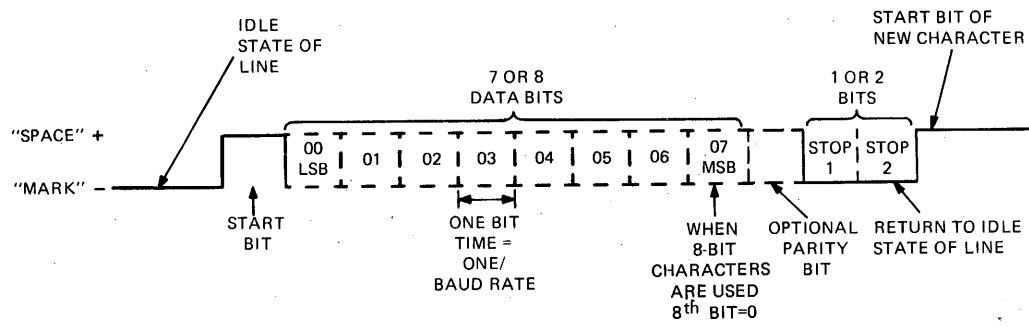

MR-1279
MA-7815

Figure 7-4 Serial Character Format

NOTE: When the VT131 terminal is receiving in HDX A, the BREAK key turns the SRTS line off for 0.275 seconds + 10 percent.

A long break (space) disconnect can always be performed when the terminal is on-line. A long break disconnect is a space condition transmitted for 3.5 seconds + 10 percent followed by the Data Terminal Ready interface signal being turned off. When the disconnect character enable SET-UP feature is on, the VT131 terminal transmits the disconnect character before the long break disconnect sequence is performed. The disconnect character is selected by the turnaround/disconnect SET-UP feature. A long break disconnect is the usual way for the terminal to disconnect from the communication line at the end of communication.

Modem Control

The VT131 terminal can communicate in either full or half duplex. Full duplex (two-way simultaneous) operation allows characters to be transmitted and received in both directions at the same time. Half duplex (two-way alternate) communication allows characters to be transmitted and received in both directions, one direction at a time. The modem control SET-UP feature has five selections. Three of the selections communicate in full duplex and two selections communicate in half duplex. The modem control SET-UP feature selections are listed in Table 7-4.

The type of communication used by the VT131 terminal is selected using the modem control SET-UP feature. The modem control used by the terminal must be compatible with the computer and modem. Table 7-5 lists the modem control feature selections and the possible modems used.

NOTE: The terminal must be certified for connection to the non-BELL modems listed in Table 7-5. These modems are used outside of continental North America and are listed for information purposes only. Contact your local Field Service Office for more information about modems and certification.

Full Duplex Communication

Full duplex (two-way simultaneous) operation allows characters to be transmitted and received in both directions at the same time. All the modem control feature selections except full duplex data leads only (FDX A) use modem control signals during communication. Modem control signals are used to ensure that the terminal and computer are properly connected before communicating.

Full Duplex with no EIA modem control (FDX A)

The FDX A selection allows the VT131 terminal to transmit and receive characters using no modem control signals (data leads only). When FDX A is selected, the terminal assumes it is connected to the computer and communication is allowed. Table 7-6 lists the signals used by the terminal in FDX A. All connector signals not listed are not used by the terminal.

NOTE: The FDX A feature selection must be used with the 20 mA current loop option (VT1XX-CA).

Table 7-4 Modem Control Feature Selections

Selection	Description	Usual Application
FDX A	Full duplex no EIA modem control (data leads only)	Full duplex communication with a null modem (direct) connection to the computer or with a modem that does not use modem control signals.
FDX B	Full duplex with EIA modem control	Full duplex communication with a modem that uses modem control signals.
FDX C	Asymmetric full duplex with EIA modem control	Full duplex communication with a half duplex modem using the secondary channel.
HDX A	Half duplex supervisory mode	Half duplex communication with the secondary channel control lines indicating when to perform line turnarounds.
HDX B	Half duplex coded control	Half duplex communication with control characters indicating when to perform line turnarounds.

Table 7-5 Possible Modem Protocol Feature and Modem Configurations

NOTE: The modems listed below are examples of possible modem configurations. Equivalent modems supplied by other manufactures may also be used.

HDX A	FDX B	FDX C	HDX A	HDX B
DF01-A Acoustic- coupler 300 baud	Bell 103 300 baud 2-wire	D1200S with reverse channel V.23 rec 1200 baud xmit 75 baud 2-wire	Bell 202 1200 baud 2-wire	Bell 202 1200 baud 2-wire
Bell 103 300 baud 2-wire	Bell 113 300 baud 2-wire	Datel 600 Modem #4 V.23 rec 600/1200 baud xmit 75 baud 2-wire	D1200S V.23 1200 baud 2-wire	D1200S V.23 1200 baud 2-wire
Bell 113 300 baud 2-wire	Bell 212A 1200 baud 2-wire dual-speed option			
Bell 212A 1200 baud 2-wire	D200/D300S V.21 200/300 baud 2-wire			
	DATEL 200 V.21 200/300 baud 2-wire			
	D1200SDX V.22 1200 baud 2-wire			
	DFG300 V.20bis, V.24 300 baud 2-wire 2-stop bits			
	DAG1200M V.23			

Table 7-5 Possible Modem Protocol Feature and Modem Configurations
(Cont)

HDX A	FDX B	FDX C	HDX A	HDX B
	1200 baud 4-wire			
	DATEL 600 Modem #5 V.23 1200 baud 4-wire			

Table 7-6 Modem Signals in Full Duplex data leads only (FDX A)

PIN NAME	MNEMONIC	CCITT/ EIA	SWITCH #	DESCRIPTION
1 Protective Ground	PGND	101/AA		Connected to the chassis of the terminal. Also, connected to external ground through the third wire of the power cord.
2 Transmit Data	TXD	103/BA	S6	FROM VT131 When switch S6 is on (closed), this conductor transmits serial characters and Break signals generated by the terminal. This conductor is in the mark state when no characters are being transmitted.
<u>NOTE: When S6 is on (closed), switch S7 must be off (open).</u>				
3 Received Data	RXD	104/BB		TO VT131 This conductor receives serial characters from the computer.
4 Request to Send	RTS	105/CA	S1	FROM VT131 When switch S1 is on (closed), this signal is on when the terminal is on-line and off when the terminal is off-line.
5 Clear to Send	CTS	106/CB	S2	TO VT131 When switch S2 is on (closed), this conductor is only used to determine if the CTS keyboard indicator is on or off. The on condition of the CTS signal turns the CTS indicator on; the off condition turns the CTS indicator off.
<u>NOTE: When S2 is on (closed), switch S3 must be off (open).</u>				

Table 7-6 Modem Signals in Full Duplex Data Leads Only (FDX A) (Cont)

PIN NAME	MNEMONIC CCITT/ EIA	SWITCH # DESCRIPTION
6 Data Set Ready	DSR	107/CC
<p>TO VT131 This conductor is only used to determine if the DSR keyboard indicator is on or off. The on condition of the DSR signal turns the DSR indicator on; the off condition turns the DSR indicator off.</p>		
7 Signal Ground	SGND	102/AB
<p>This conductor is the common ground reference potential for all connector signals except protective ground. This conductor is connected to the protective ground conductor.</p>		
20 Data Terminal Ready DTR		108.2/CD
<p>FROM VT131 This signal is on when the terminal is on-line and off when the terminal is off-line or a line disconnect is being performed. The on condition usually allows the modem to answer calls (modem auto answer option). The off condition usually causes the modem to disconnect and not answer calls.</p>		

FDX A Connect Conditions - Before the computer and terminal communicate, they use modem control signals to verify that they are properly connected. The modem control signals used are determined by the modem control SET-UP feature selection. In FDX A, the terminal is assumed to be connected at all times except during a long break disconnect or when the terminal is off-line.

The Data Terminal Ready signal (from the VT131) is on whenever the VT131 terminal is considered connected. Communication is allowed when the Data Terminal Ready (DTR) signal is on regardless of the condition of the other modem control lines.

The VT131 terminal prepares to connect to the computer for communication immediately after DTR is turned off. The VT131 terminal prepares to communicate by:

- ^ erasing the keyboard buffer and turning off the KBD LOCKED indicator (if a keyboard locked condition has occurred).
- ^ stopping print operations and any print operations requested are not performed.
- ^ using the character set selected by the US/UK character set SET-UP feature (any computer selected character sets are not used).
- ^ if the auto XON/XOFF SET-UP feature is selected, transmission is allowed in both directions (assume XON).

FDX A Disconnect Conditions - The terminal disconnects (hangs up) the communication (telephone) line whenever it is not ready to communicate. A disconnect is performed by turning the Data Terminal Ready signal off. A disconnect is performed when:

- ^ the VT131 terminal is switched off-line.
- ^ a recall, reset or general default is performed.
- ^ a long break disconnect is performed (SHIFT and BREAK key sequence). A disconnect character is transmitted if the disconnect character enable SET-UP feature is on.
- ^ a disconnect character is received and the disconnect character enable SET-UP feature is on.

Full Duplex with modem controls (FDX B)

The FDX B selection allows the VT131 terminal to transmit to the computer while using modem control signals. The modem control signals are used to ensure that a connection exists between the terminal and computer before and during communication. If the connection does not exist, communication is not permitted. This selection is used when communicating with a computer through a

full duplex modem which uses modem control signals. Table 7-7 lists the signals used by the VT131 terminal in FDX B. All connector signals not listed are not used by the terminal. This selection supports speed select on the modem.

FDX B Connection Conditions - Before the computer and terminal communicate, they use modem control signals to verify that they are connected. The modem control signals used are determined by the modem control SET-UP feature selection. In FDX B, the VT131 terminal must be on-line and the Clear to Send, Receive Line Signal Detector and Data Set Ready signals from the modem must be on. The DSR and CTS keyboard indicators are on. If these signals are not generated by the modem, the full duplex data leads only (FDX A) selection should be used.

The VT131 terminal prepares to connect to the computer for communication when the Data Set Ready signal to the terminal is turned on. The VT131 terminal prepares to communicate by:

- ^ erasing the keyboard buffer and turning off the KBD LOCKED indicator (if a keyboard locked condition has occurred).
- ^ stopping print operations and any print operations requested are not performed.
- ^ using the character set selected by the US/UK character set SET-UP feature (any computer selected character sets are not used).
- ^ selecting keypad numeric mode (the auxiliary keypad generates numeric characters). The cursor keys transmit cursor movement commands.
- ^ selecting replace mode (turns off insert mode). The INSERT indicator is off and all received characters are displayed at the cursor position, replacing any previously displayed character.
- ^ if the auto XON/XOFF SET-UP feature is selected, transmission is allowed in both directions (assume XON).

FDX B Disconnect Conditions - The terminal disconnects from the communication line whenever the terminal is not ready to communicate. A disconnect is performed by turning the Data Terminal Ready signal off. A disconnect is performed when:

- ^ the VT131 terminal is switched off-line.
- ^ a recall, reset or general default is performed.
- ^ the VT131 terminal receives a disconnect character and the disconnect character enable SET-UP feature is on.

Table 7-7 Full Duplex With Modem Control (FDX B)

PIN NAME	MNEMONIC	CCITT/ EIA	SWITCH #	DESCRIPTION
1 Protective Ground	PGND	101/AA		Connected to the chassis of the terminal. Also, connected to external ground through the third wire of the power cord.
2 Transmit Data	TXD	103/BA	S6	FROM VT131 When switch S6 is on (closed), this conductor transmits serial characters and Break signals generated by the terminal. This conductor is in the mark state when no characters are being transmitted.
<u>NOTE: When S6 is on (closed), switch S7 must be off (open).</u>				
3 Received Data	RXD	104/BB		TO VT131 This conductor receives serial characters from the computer.
4 Request to Send	RTS	105/CA	S1	FROM VT131 When switch S1 is on (closed), this signal is on when the terminal is on-line and off when the terminal is off-line.
5 Clear to Send	CTS	106/CB	S2	TO VT131 When switch S2 is on (closed), this conductor is used to indicate when the modem is ready to transmit data. When on, the modem is ready to transmit data and CTS keyboard indicator is on. When off, the modem is not ready to transmit data and the CTS keyboard indicator

Table 7-7 Full Duplex With Modem Control (FDX B) (Cont)

PIN NAME	MNEMONIC CCITT/ EIA	SWITCH # DESCRIPTION
		is off.
NOTE: When S2 is on (closed), switch S3 must be off (open).		
6 Data Set Ready	DSR	107/CC
		<p>TO VT131</p> <p>When this signal is on:</p> <ul style="list-style-type: none"> * the DSR keyboard indicator is on * the modem is connected to a communication line * the modem is ready to use the modem control signals. <p>When this signal is off:</p> <ul style="list-style-type: none"> * the DSR keyboard indicator is off * the terminal performs a disconnect
7 Signal Ground	SGND	102/AB
		<p>This conductor is the common ground reference potential for all connector signals except protective ground. This conductor is connected to the protective ground conductor.</p>
8 Receive Line Signal Detector	RLSD	109/CF
		<p>TO VT131</p> <p>Also called Carrier Detect, this signal is on when the signals used by the communication line are good enough to transfer data. When off, the signals of the communication line are not good enough to transfer data. Data received when this signal is off is ignored.</p>

Table 7-7 Full Duplex With Modem Control (FDX B) (Cont)

PIN NAME	MNEMONIC CCITT/ EIA	SWITCH DESCRIPTION #
12 Speed Indicator	SI	112/CI
		<p>S4 T0 VT131 When switch S4 is on (closed), this signal controls the terminal transmit and receive speeds. When on, the transmit and receive speeds of the terminal are 1200 baud regardless of the modem transmit and receive speed SET-UP feature selections. When off, the transmit and receive speeds are the modem transmit and receive speed SET-UP feature selections.</p>
20 Data Terminal Ready DTR		108.2/CD
		<p>FROM VT131 This signal is on when the terminal is on-line and off when the terminal is off-line or a disconnect is being performed. The on condition usually allows the modem to answer calls (modem auto answer option). The off condition usually causes the modem to disconnect and not answer calls.</p>
23 Speed Select	SPSD	111/CH
		<p>S10 FROM VT131 This signal is on when the receive speed SET-UP feature selection is greater than 600 baud. This signal is off when the selected baud rate is 600 baud or less.</p>

- ^ a long break disconnect is performed (SHIFT and BREAK key sequence). A disconnect character is transmitted if selected by the turnaround/disconnect character SET-UP feature.
- ^ Data Set Ready turns off during communication.
- ^ after a connection, the loss of RLSD for a greater time than allowed by the disconnect delay SET-UP feature.
- ^ during a connection RLSD is not turned on within 30 seconds after DSR is turned on.

Asymmetric Full Duplex (FDX C)

Asymmetric full duplex is full duplex communication using a half duplex modem with a secondary channel. The secondary channel of the half duplex modem provides full duplex communication by allowing the terminal to transmit characters on the secondary channel. The VT131 terminal receives characters on the primary channel at 600 or 1200 baud and transmits characters on the secondary channel at 75 baud. The Secondary Clear to Send and Secondary Request to Send signals are used instead of Clear to Send and Request to Send signals, respectively. The connector signal assignments are selected using the internal communication switches of the terminal. Table 7-8 lists the signals used by the terminal in FDX C. All connector signals not listed are not used by the terminal.

NOTE: The modem must support secondary channel to use the FDX C (asymmetric full duplex selection).

FDX C Connection conditions - Before the computer and terminal communicate, they use modem control signals to verify that they are connected. The modem control signals used are determined by the modem control SET-UP feature selection. When FDX C is selected, the VT131 terminal must be on-line and the Secondary Clear to Send, Receive Line Signal Detector, and Data Set Ready signals to the terminal must be on. The DSR and CTS indicators are on.

The VT131 terminal prepares to connect to the computer for communication when the Data Set Ready signal to the terminal is turned on. The VT131 terminal prepares to communicate by:

- ^ erasing the keyboard buffer and turning off the KBD LOCKED indicator (if a keyboard locked condition has occurred).
- ^ stopping print operations and any print operations requested are not performed.
- ^ using the character set selected by the US/UK character set SET-UP feature (any computer selected character sets are not used).

Table 7-8 Asymmetric Full Duplex with Modem Control (FDX C)

PIN NAME	MNEMONIC	CCITT/ EIA	SWITCH #	DESCRIPTION
1 Protective Ground	PGND	101/AA		Connected to the chassis of the terminal. Also, connected to external ground through the third wire of the power cord.
3 Received Data	RXD	104/BB		TO VT131 This conductor receives serial characters from the computer.
6 Data Set Ready	DSR	107/CC		FROM VT131 When this signal is on: * the DSR keyboard indicator is on * the modem is connected to a communication line * the modem is ready to use the modem control signals. When this signal is off: * the DSR keyboard indicator is off * the terminal performs a disconnect
7 Signal Ground	SGND	102/AB		This conductor is the common ground reference potential for all connector signals except protective ground. This conductor is connected to the protective ground conductor.
8 Receive Line Signal Detector	RLSD	109/CF		TO VT131 Also called Carrier Detect, this signal is on when the signals used by the communication line are good enough to transfer

Table 7-8 Asymmetric Full Duplex with Modem Control (FDX C) (Cont)

PIN NAME	MNEMONIC CCITT/ EIA	SWITCH DESCRIPTION #
13 Secondary Clear to Send	SCTS	121/SCB S3
<p>data. When off, the signals of the communication line are not good enough to transfer data. Data received when this signal is off is ignored.</p>		
<p>TO VT131 When switch S3 is on (closed), this conductor is used to indicate when the modem is ready to transmit data. When on, the modem is ready to transmit data and the CTS keyboard indicator is on. When off, the modem is not ready to transmit data and the CTS keyboard indicator is off.</p>		
<p><u>NOTE: When S3 is on (closed), switch S2 must be off (open).</u></p>		
14 Secondary Transmit Data	STXD	118/SBA S7
<p>When switch S7 is closed, this conductor transmits serial characters and Break signals generated by the terminal. This conductor is in the mark state when no characters are being transmitted.</p>		
<p><u>NOTE: When S7 is on (closed), switch S6 must be off (open).</u></p>		
19 Secondary Request to Send	SRTS	120/SCA S8
<p>TO VT131 When switch S8 is closed, this signal is on when the terminal is on-line and off when the terminal is off-line.</p>		

Table 7-8 Asymmetric Full Duplex with Modem Control (FDX C) (Cont)

PIN NAME	MNEMONIC CCITT/ EIA	SWITCH DESCRIPTION #
----------	------------------------	-------------------------

NOTE: Switch S5 must be off (open).

20 Data Terminal Ready 108.2/CD	DTR FROM VT131 This signal is on when the terminal is on-line and off when the terminal is off-line or a disconnect is being performed. The on condition usually allows the modem to answer calls (modem auto answer option). The off condition usually causes the modem to disconnect and not answer calls.
---------------------------------	---

- ^ selecting keypad numeric mode (the auxiliary keypad generates numeric characters). The cursor keys transmit cursor movement commands.
- ^ selecting replace mode (turn off insert mode). The INSERT indicator is off and all received characters are displayed at the cursor position, replacing any previously displayed character.
- ^ if the auto XON/XOFF SET-UP feature is selected, transmission is allowed in both directions (assume XON).

FDX C Disconnect Conditions - The terminal disconnects from the communication line whenever the terminal is not ready to communicate. A disconnect is performed by turning the Data Terminal Ready signal off. A disconnect is performed when:

- ^ the VT131 terminal is placed off-line.
- ^ a recall, reset or general default is performed.
- ^ the VT131 terminal receives a disconnect character and the disconnect character enable SET-UP feature is on.
- ^ a long break disconnect is performed (SHIFT and BREAK key sequence). A disconnect character is transmitted if the disconnect character enable SET-UP feature is on.
- ^ Data Set Ready turns off during communication.
- ^ after a connection, the loss of RLSD for a greater time than allowed by the disconnect delay SET-UP feature.
- ^ during a connection RLSD is not turned on within 30 seconds after DSR is turned on.

Half Duplex

Half duplex communication allows communication between the VT131 terminal and the computer in both directions, one direction at a time. Due to the "one direction at a time" definition of half duplex, a method of determining when to transmit and when to receive is needed. Also, every time the transmitting device is to receive, the communication line is "turned around". Line turnaround is performed by switching which device (the computer or terminal) turns on Request to Send causing the modem to generate a carrier signal. When RTS is on, the modem generates a line (carrier) signal and can transmit characters. When the initial connection to the communication line occurs, the terminal must determine which device is to begin transmission. The initial direction SET-UP feature determines the transmitting and receiving device.

NOTE: When operating in half duplex, characters typed on the keyboard are not immediately displayed on the screen unless the local echo feature is selected.

The VT131 terminal uses one of two types of half duplex communication to control line direction: half duplex with supervisory control and half duplex with coded control.

Half Duplex with supervisory control (HDX A)

Half duplex with supervisory control allows the computer to control line turnaround using secondary channel control signals. The computer uses the Secondary Request to Send and Secondary Receive Line Signal Detector to control line turnaround. Therefore, the half duplex modem must have secondary channel. However, when HDX A is selected, the secondary channel is not used to transfer data. Table 7-9 lists the signals used by the terminal in HDX A. All connector signals not listed are not used by the terminal.

HDX A Connect Conditions - Before the computer and terminal communicate, they use modem control signals to verify that they are connected. The modem control signals used are determined by the modem control SET-UP feature selection. When HDX A is selected, the VT131 terminal must be on-line and the Data Set Ready signal must be on.

The VT131 terminal prepares to connect to the computer for communication when the Data Set Ready signal to the terminal is turned on. The VT131 terminal prepares to communicate by:

- ^ erasing the keyboard buffer and turning off the KBD LOCKED indicator (if a keyboard locked condition has occurred).
- ^ stopping print operations and any print operations requested are not performed.
- ^ using the character set selected by the US/UK character set SET-UP feature (any computer selected character sets are not used).
- ^ selecting keypad numeric mode (the auxiliary keypad generates numeric characters). The cursor keys transmit cursor movement commands.
- ^ selecting replace mode (turn off insert mode). The INSERT indicator is off and all received characters are displayed at the cursor position, replacing any previously displayed character.
- ^ determining the initial direction of transmission using the initial direction SET-UP feature.

Table 7-9 Half Duplex with Supervisory Control (HDX A)

PIN NAME	MNEMONIC	CCITT/ EIA	SWITCH #	DESCRIPTION
1 Protective Ground	PGND	101/AA		Connected to the chassis of the VT131. Also, connected to external ground through the third wire of the power cord.
2 Transmit Data	TXD	103/BA	S6	FROM VT131 When switch S6 is on (closed), signals on this conductor are serial characters and Break signals generated by the terminal. This conductor is in the mark state when no characters are being transmitted.
<u>NOTE: When switch S6 is on (closed), switch S7 is off (open).</u>				
3 Received Data	RXD	104/BB		TO VT131 This conductor receives serial characters from the computer.
4 Request to Send	RTS	105/CA	S1	FROM VT131 When switch S1 is on (closed), this signal is on when the terminal is ready to transmit characters and off when the terminal is receiving characters.
5 Clear to Send	CTS	106/CB	S2	TO VT131 When switch S2 is on (closed), this conductor is used to indicate when the modem is ready to transmit data to the computer. When on, the modem is ready to transmit data and the CTS keyboard indicator is on. When off, the modem is not

Table 7-9 Half Duplex with Supervisory Control (HDX A) (Cont)

PIN NAME	MNEMONIC CCITT/ EIA	SWITCH DESCRIPTION #	
			ready to transmit data and the CTS keyboard indicator is off.
<u>NOTE: When switch S2 is on (closed), switch S3 is off (open).</u>			
6 Data Set Ready	DSR	107/CC	<p>FROM VT131</p> <p>When this signal is on:</p> <ul style="list-style-type: none"> * the DSR keyboard indicator is on * the modem is connected to a communication line * the modem is ready to use the modem control signals. <p>When this signal is off:</p> <ul style="list-style-type: none"> * the DSR keyboard indicator is off * the VT131 performs a disconnect
7 Signal Ground	SGND	102/AB	<p>This conductor is the common ground reference potential for all connector signals except protective ground. This conductor is connected to the protective ground conductor.</p>
8 Receive Line Signal Detector	RLSD	109/CF	<p>TO VT131</p> <p>Also called Carrier Detect, this signal is on when the signals used by the communication line are good enough to receive data from the computer. When off, the VT131 is transmitting data to the computer or the modem is disconnected from the communication line. Data received when this signal is off is ignored.</p>

Table 7-9 Half Duplex with Supervisory Control (HDX A) (Cont)

PIN NAME	MNEMONIC	CCITT/ EIA	SWITCH #	DESCRIPTION
12 Secondary Receive Line Signal Detector	SRLSD	122/SCF	S4	TO VT131 Also called Secondary Carrier Detect, this signal is on when transmitting to the computer. When off, the VT131 is receiving data from to the computer or the modem is disconnected from the communication line.
19 Secondary Request to Send	SRTS	120/SCA	S8	FROM VT131 When switch S8 is on (closed), this signal is on when the terminal is ready to receive characters and off when the terminal is transmitting characters.
<u>NOTE: Switch S5 must be off (open).</u>				
20 Data Terminal Ready	DTR	108.2/CD		FROM VT131 This signal is on when the terminal is on-line and off when the terminal is off-line or a line disconnect is being performed. The on condition usually allows the modem to answer calls (modem auto answer option). The off condition usually causes the modem to disconnect and not answer calls.

HDX A Transmission and Reception of Characters - When the connection between the terminal and computer is complete the secondary channel modem control signals are used to control line turnaround. The terminal receives data when:

Computer

The computer turns off Secondary Request to Send.

Terminal

This causes the Secondary Receive Line Signal Detector signal to the terminal to turn off. The terminal turns off the Request to Send signal. (The Clear to Send signal turns off.)

This causes the Receive Line Signal Detector signal to the computer to turn off. The computer turns on the Request to Send signal.

This causes the Receive Line Signal Detector signal to the terminal to turn on. The terminal turns on the Secondary Request to Send signal.

This causes the Secondary Receive Line Signal Detector signal to the computer to turn on.

The terminal receives the characters transmitted by the computer.

The terminal transmits data when:

Computer

The computer turns off the Request to Send signal and turns on the Secondary Request to Send signal.

Terminal

This causes the Receive Line Signal Detector signal to the terminal to turn off and the Secondary Receive Line Signal Detector signal to turn on. The terminal then turns off the Secondary Request to Send signal and turns on the Request to Send signal.

This causes the Secondary Receive Line Signal Detector to the computer to turn off. The Receive Line Signal Detector signal to the computer turns on.

The VT131 waits for the CTS signal to turn on allowing the transmission of characters to the computer.

Table 7-10 provides a summary of the conditions of the modem signals when transmitting and receiving characters.

HDX A Disconnect Conditions - The terminal disconnects from the communication line whenever the terminal is not ready to communicate. A disconnect is performed by turning the Data Terminal Ready signal off. A disconnect is performed when:

- ^ the terminal is switched off-line.
- ^ a recall, reset or general default is performed.
- ^ the VT131 receives a disconnect character and the disconnect character enable SET-UP feature is on.
- ^ a long break disconnect is performed (SHIFT and BREAK key sequence). A disconnect character is transmitted if the disconnect character enable SET-UP feature is on.
- ^ DSR turns off during communication.
- ^ line turnaround not completed within 5 seconds.

Half Duplex using Code Control (HDX B)

Coded control is the use of turnaround characters to control line turnaround. The transmitting device controls line turnarounds by transmitting a turnaround character specified by the turnaround/disconnect character SET-UP feature. The turnaround character indicates that line should be turned around by the terminal and computer using modem control lines. Table 7-11 lists the signals used by the terminal in HDX B. All connector signals not listed are not used by the terminal.

The turnaround characters used by the terminal are the ETX and EOT characters. The DC3, FF, and CR characters can also be selected, however these characters are used in violation of ANSI X3.3. If the line turnaround SET-UP feature is selected for auto, the line is automatically turned around when:

- ^ the answerback message is transmitted
- ^ a cursor position report is transmitted

Table 7-10 HDX A Modem Control Line Summary

Modem Control Line	Source	Receive Condition	Transmit Condition
Data Terminal Ready	From VT131	On	On
Data Set Ready	To VT131	On	On
Request to Send	From VT131	Off	On
Clear to Send	To VT131	Off	On
Receive Line Signal Detector	To VT131	On	Off
Secondary Request to Send	From VT131	On	Off
Secondary Receive Signal Detector	To VT131	Off	On

Table 7-11 Half Duplex using Coded Control (HDX B)

PIN NAME	MNEMONIC	CCITT/ EIA	SWITCH #	DESCRIPTION
1 Protective Ground	PGND	101/AA		Connected to the chassis of the VT131. Also, connected to external ground through the third wire of the power cord.
2 Transmit Data	TXD	103/BA	S6	FROM VT131 When switch S6 is on (closed), signals on this conductor are serial characters and Break signals generated by the terminal. This conductor is in the mark state when no characters are being transmitted.
<u>NOTE: When switch S6 is on (closed), switch S7 must be off (open).</u>				
3 Received Data	RXD	104/BB		TO VT131 This conductor receives serial characters from the computer.
4 Request to Send	RTS	105/CA	S1	FROM VT131 When switch S1 is on (closed), this signal is on when the terminal is ready to transmit characters and off when the terminal is receiving characters.
5 Clear to Send	CTS	106/CB	S2	TO VT131 When switch S2 is on (closed), this conductor is used to indicate when the modem is ready to transmit data to the computer. When on, the modem is ready to transmit data and the CTS keyboard indicator is on. When off, the modem is not ready to transmit data and the CTS keyboard indicator is off.

Table 7-11 Half Duplex using Coded Control (HDX B) (Cont)

PIN NAME	MNEMONIC CCITT/ EIA	SWITCH DESCRIPTION #
NOTE: When switch S2 is on (closed), switch S3 must be off (open).		
6 Data Set Ready	DSR	107/CC
<p>FROM VT131</p> <p>When this signal is on:</p> <ul style="list-style-type: none"> * the DSR keyboard indicator is on * the modem is connected to a communication line * the modem is ready to use the modem control signals. <p>When this signal is off:</p> <ul style="list-style-type: none"> * the DSR keyboard indicator is off * the VT131 performs a disconnect 		
7 Signal Ground	SGND	102/AB
<p>This conductor is the common ground reference potential for all connector signals except protective ground. This conductor is connected to the protective ground conductor.</p>		
8 Receive Line Signal Detector	RLSD	109/CF
<p>TO VT131</p> <p>Also called Carrier Detect, this signal is on when the signals used by the communication line are good enough to receive data from the computer. When off, the VT131 is transmitting data to the computer or the modem is disconnected from the communication line. Data received when this signal is off is ignored.</p>		

Table 7-11 Half Duplex using Coded Control (HDX B) (Cont)

PIN NAME	MNEMONIC	CCITT/ EIA	SWITCH #	DESCRIPTION
20 Data Terminal Ready	DTR	108.2/CD		FROM VT131 This signal is on when the terminal is on-line and off when the terminal is off-line or a line disconnect is being performed. The on condition usually allows the modem to answer calls (modem auto answer option). The off condition usually causes the modem to disconnect and not answer calls.

- ^ a device status report is transmitted
- ^ a device attributes is transmitted
- ^ the RETURN key is pressed. If the turnaround character is CR, only one CR character is transmitted.

If the line turnaround SET-UP feature is selected for manual, the turnaround character must be manually selected from the keyboard.

HDX B Connection - Before the computer and terminal communicate, they use modem control signals to verify that they are connected. The modem control signals used are determined by the modem control SET-UP feature selection. When HDX B is selected, the VT131 terminal must be on-line and the Data Set Ready signal must be on.

The VT131 terminal prepares to connect to the computer for communication when the Data Set Ready signal to the terminal is turned on. The VT131 terminal prepares to communicate by:

- ^ erasing the keyboard buffer and turning off the KBD LOCKED indicator (if a keyboard locked condition has occurred).
- ^ stopping print operations and any print operations requested are not performed.
- ^ using the character set selected by the US/UK character set SET-UP feature (any computer selected character sets are not used).
- ^ selecting keypad numeric mode (the auxiliary keypad generates numeric characters). The cursor keys transmit cursor movement commands.
- ^ selecting replace mode (turn off insert mode). The INSERT indicator is off and all received characters are displayed at the cursor position, replacing any previously displayed character.
- ^ determining the initial direction of transmission using the initial direction SET-UP feature.

HDX B Transmission and Reception of Characters - When the connection between the terminal and computer is complete the turnaround characters and modem control signals are used to control line turnaround. The terminal receives data when:

Computer

Terminal

The computer turns on the Request to Send signal.

The Receive Line Signal Detector signal to the terminal is turned on. The Request to Send signal from the terminal is off, therefore the Clear to Send signal to the terminal is off. The terminal receives characters from the computer.

The terminal transmits characters when:

It receives a turnaround character, the terminal turns the Request to Send signal on.

This causes the Receive Line Signal Detector to the computer to turn on.

The Clear to Send signal to the terminal turns on. The terminal can transmit characters.

Table 7-12 provides a summary of the conditions of the modem signals when transmitting and receiving characters.

HDX B Disconnect Conditions - The terminal performs a disconnect by transmitting and turning off the Data Terminal Ready signal. A disconnect is performed when:

- ^ the terminal is switched off-line.
- ^ a recall, reset or general default is performed
- ^ the terminal receives a disconnect character and the disconnect character enable SET-UP feature is on.
- ^ the long break disconnect is performed (SHIFT and BREAK key sequence). A disconnect character is transmitted if selected by the disconnect character enable SET-UP feature.
- ^ DSR turns off during communication.
- ^ loss of RLSD for more than 5 seconds without receiving a turnaround character.
- ^ line turnaround not completed within 5 seconds.

Input Buffer Overflow Prevention

When the terminal receives a character (other than the NUL and DEL characters), the character is placed in a 128 character input buffer. The input buffer holds the received character until the terminal processes the character. When processed, the character is removed from the input buffer.

Table 7-12 HDX B Modem Control Line Summary

Modem Control Line	Source	Receive Condition	Transmit Condition
Data Terminal Ready	From VT131	On	On
Data Set Ready	To VT131	On	On
Request to Send	From VT131	Off	On
Clear to Send	To VT131	Off	On
Receive Line Signal Detector	To VT131	On	Off

If received characters are placed in the input buffer faster than the characters are processed, the input buffer begins to fill with characters. When the input buffer is full, received characters are lost and the Substitute character (D) is displayed. There are three methods of input buffer overflow prevention:

- ^ XON/XOFF Characters
- ^ Fill Characters
- ^ Low Speed Operation

XON and XOFF Control Characters - Input buffer overflows can be prevented using the XON and XOFF control characters, this method is recommended when using full duplex communication. When using the auto XON/XOFF SET-UP feature, the XON and XOFF control characters are used to indicate the number of characters in the input buffer. When the 128 character input buffer of the terminal holds 32 characters, the terminal transmits XOFF (DC3, octal 023). The computer should stop transmitting characters.

If the computer fails to respond to the XOFF character transmitted by the terminal, the input buffer continues to fill. The terminal transmits a second XOFF when the input buffer holds 112 characters. This second XOFF is a last request to the computer to stop transmitting characters.

As the terminal continues to remove characters from the input buffer, the number of characters in the buffer decreases. When 16 characters remain in the input buffer, the terminal transmits XON (DC1, octal 021) requesting the computer to continue transmission.

To determine how fast the computer must respond the first XOFF character to avoid input buffer overflow, use the following formulas:

No. of characters to overflow = $96 - [3 \times (\text{receiver speed} / \text{transmit speed})]$

Time to respond to XOFF (in seconds) = $\text{No. of characters to overflow} \times (\text{bits per character} + \text{parity bit} + \text{number of stop bits} + 1) / \text{receiver speed}$

Example 1:

The terminal transmitting 8-bit characters with no parity at 1200 baud and receiving at 1200 baud. When the terminal transmits the first XOFF, the computer must stop transmitting within 0.775 seconds or the input buffer overflows.

No. of characters to overflow = $96 - [3 \times (1200/1200)] = 93$ characters

Time to respond to XOFF = $93 \times (8+0+1+1)/1200 = 0.775$ second

Example 2:

The terminal is transmitting 7-bit characters with parity at 300 baud and receiving at 300 baud. The terminal transmits the first XOFF, the computer must stop transmitting within 3.1 seconds or the input buffer overflows.

No. of characters to overflow = $96 - [3 \times 300/300] = 93$ characters

Time to respond to XOFF = $93 \times (7+1+1+1)/300 = 3.1$ seconds

NOTE: If the input buffer overflows, received characters are ignored and the Substitute character (D) is displayed.

Fill Characters

The computer can prevent input buffer overflows using fill characters during communication. The computer can use the Null character (octal 000) as a fill character to prevent input buffer overflows. When received by the terminal, the Null character is not placed in the input buffer. Therefore, the terminal does not process the Null character. This allows the terminal to process previously received characters while Null characters are being transmitted by the computer.

Fill characters are transmitted to the terminal after each control function or displayable character. Therefore, the terminal can process a control function or character before receiving more characters. The number of fill characters transmitted by the computer after a control function or character depends on both the control function transmitted and the receive speed of the terminal. Table 7-13 lists the number of fill characters used when transmitting to the terminal.

Low Speed Operation - Input buffer overflows can be prevented when the terminal receives characters at a speed slower than the characters can be processed. Therefore, the terminal always removes characters from the input buffer faster than the characters can be received from the computer. When the terminal is using a low receive speed (baud rate) to prevent input buffer overflows, use the following rules:

- ^ the computer never sends the ESC code to the terminal
- ^ the receive speed of the terminal is 4800 baud or less
- ^ the smooth scroll feature can not be used

Effects of Reset and Tests - Two control sequences, reset (RIS) and invoke confidence test (DECTST), initialize the terminal and erase the input buffer. This means that characters received while these two functions are processed are lost. Therefore, the computer may act in one of two ways:

Table 13 Suggested Fill Character Requirements

PARAMETER										
Baud Rate	IND,LF, NEL,RI, (Smooth Scroll)	DECCOLM	DECALN	ED (132 Col)	ED (80 Col)	IND,LF, NEL,RI, (Jump Scroll)	EL (132 col)	EL (80 col)	DECINLM	All others except RIS, and DECTST
19200	324	191	190	144	104	32	6	4	7	2
9600	162	96	95	72	52	16	3	2	3	1
4800	81	48	48	36	26	8	1	1	2	0
3600	61	36	36	27	20	6	1	1	1	0
2400	41	24	24	18	13	4	1	1	1	0
2000	34	20	20	15	11	3	1	0	1	0
1800	30	18	18	14	10	3	1	0	0	0
1200	20	12	12	9	7	2	0	0	0	0
600	10	6	6	5	3	1	0	0	0	0
300	5	3	3	2	2	0	0	0	0	0
200	3	2	2	2	1	0	0	0	0	0
150	3	1	1	1	1	0	0	0	0	0
134.5	2	1	1	1	1	0	0	0	0	0
110	2	1	1	1	1	0	0	0	0	0
75	1	1	1	1	0	0	0	0	0	0
50	1	0	0	0	0	0	0	0	0	0

7-41

1. If the auto XON/XOFF feature is used, immediately after sending the reset or invoke confidence test sequences, the computer may assume an XOFF from terminal. The computer sends no more characters until it receives XON. The terminal transmits XON only after it completes the reset or test.
2. When the first method cannot be used, a delay of no less than 10 seconds may be used to allow the terminal to complete the function. This method, however, does not guarantee against loss of characters when a reset or test has detected an error.

NOTE: The reset and invoke confidence test sequences cause the terminal to disconnect from the communication line.

KEYBOARD TRANSMIT BUFFER

The keyboard transmit buffer holds characters generated by the terminal before they are transmitted to the computer. When using the auto XON/XOFF feature in full duplex, the computer can use the XON (DC1, octal 021) and XOFF (DC3, octal 023) characters to control the transmission of characters from the terminal.

NOTE: The use of the XON and XOFF characters is the only method used to control the transmission of characters from the terminal to the computer in full duplex.

Receipt of XOFF stops the terminal from transmitting any characters except XOFF and XON. From three to seven keystrokes are stored in a keyboard buffer. If the keyboard buffer overflows, the KBD LOCKED indicator turns on and keyclicks stop (if the keyclick SET-UP feature is on).

When XON is received, the transmission of characters continues. Also, entering and exiting SET-UP turns off the KBD LOCKED indicator and allows the terminal to transmit characters. However, characters transmitted after entering and exiting SET-UP may be lost if the computer is not ready to receive characters. When the keyboard buffer is empty, the KBD LOCKED indicator is turned off and keyclicks occur when keys are pressed (If the keyclick SET-UP feature is on).

CONNECTING TO THE PRINTER

The VT131 terminal connects to a local serial printer using a printer interface. The printer interface is full duplex with no modem control (data leads only) and uses the XON/XOFF characters to prevent the printers input buffer from overflowing. The printers recommended for use with the VT131 terminal are listed in Table 7-14 with the recommended printer options and cables.

When using a serial printer with the VT131 terminal, the terminal should communicate with the computer using full duplex communication. Also, the XON/XOFF control characters should be used to prevent the terminals input buffer from overflowing. If

Table 7-14 Applicable DEC Serial Printers

Printer	Recommended Options	Option Description
LA34	LAX34-LL or LAX34-PL	Paper low detection Paper out detection
LA35	LAXX-KG LAXX-LZ*	EIA interface (LAXX-LG = 5 LAXX-KA) Paper fault detection
LA36	LAXX-KG LAXX-LZ*	EIA interface (LAXX-LG = 5 LAXX-KA) Paper fault detection
LA38	(No Options Required)	
LA120	(No Options Required)	
LA180	LAXX-NW or LAXX-NX	Serial EIA interface Serial EIA and 20 mA interface

* Paper fault detection is standard on LA35-CE, LA35-CJ, LA36-CE and LA36-CJ models. All other models of the LA35 and LA36 must order this option. The option can be ordered from the Accessories and Supplies Group or Terminal Products Group customers. (Refer to the Ordering Information section of this chapter for more information on ordering printer options.)

the VT131 terminal is communicating with the computer in half duplex or does not use the XON/XOFF characters for buffer overflow prevention, it is impossible to guarantee correct operation of the printer in every system. However, a large input buffer in the printer and the fastest transmit and receive speed (baud rate) possible by the printer, decrease the chance of operational problems.

Serial Printer Interface

The VT131 terminal communicates with the printer using a printer interface. The interface is a DB-25 (EIA RS-232-C type) male connector mounted on the back of the terminal as shown in Figure 7-5. This interface meets Electronic Industry Association (EIA) standard RS-423, RS-232-C and International Telegraph and Telephone Consultive Committee (CCITT) recommendation V.28. The pin assignments are listed in Table 7-15. All connector signals not listed are not used by the terminal.

The printer operates in full duplex with no modem control (data leads only) using the XON/XOFF characters for input buffer overflow prevention. If possible, the printer should turn off the DTR signal when not ready to print. The DTR signal has a higher priority than the XOFF character. The terminal will not transmit to the printer even when an XON is received, when the DTR signal is off. Also, if the DTR signal is turned on, the terminal assumes XON.

Printer Serial Characters

The VT131 communicates with the serial printer using 7-bit serial characters. A 7-bit serial character is transmitted using a start bit, 7 or 8 data bits (per character), an optional parity bit and one or two stop bit(s). The data bits are transmitted with the least significant bit first. Refer to ANSI X3.15-1976 for more details on the character format. Figure 7-4 shows the serial character format used.

The number of data bits in the character, the parity, the number stop bits and the speed of transmission are selected using SET-UP features. The number of data bits and parity of the printer interface are selected using the printer data/parity bits SET-UP feature. If 8-bit characters are selected the last data bit is forced to the Space (0) condition. The last data bit is ignored when received. If parity is not selected, the parity bit is not transmitted. The number of stop bits (1 or 2) and speed (baud rate) at which the serial character is selected by the transmit/receive speed SET-UP feature.

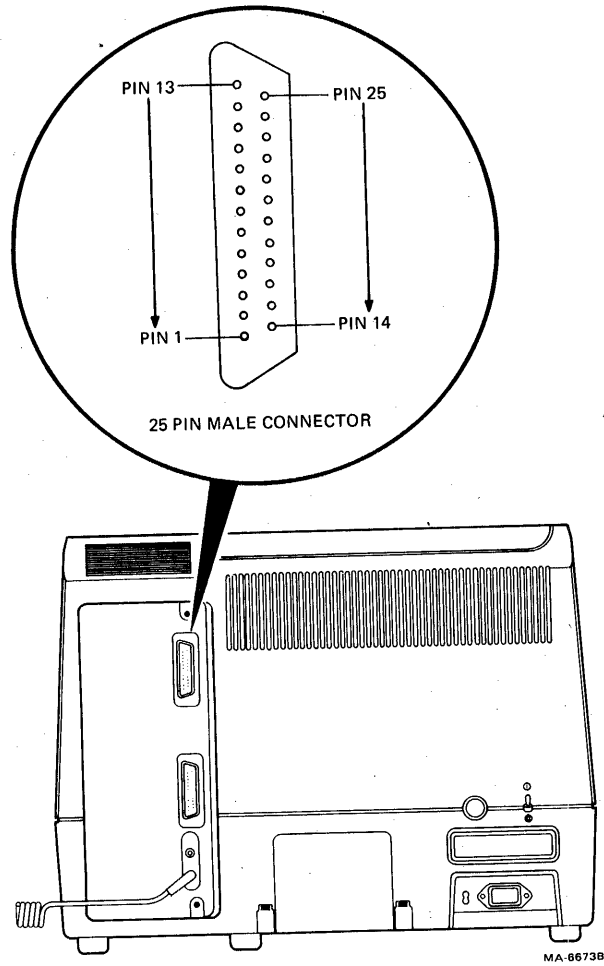

Figure 7-5 Printer Connector Location and Pin Numbering

Table 7-15 Printer Interface Signals

PIN NAME	MNEMONIC	CCITT/ EIA	DESCRIPTION
1 Chassis Ground	PGND	101/AA	Connected to the chassis of the terminal. Also, connected to the external ground lead of the ac power cord.
2 Transmit Data	TXD	103/BA	FROM VT131 The terminal transmits serial characters to the printer on this conductor. The conductor is held in the mark state when characters are not being transmitted.
3 Receive Data	RXD	104/BB	TO VT131 The terminal receives the XON and XOFF control characters on this conductor. All other characters are ignored.
6 Data Set Ready	DSR	107/CC	TO VT131 The terminal receives Data Terminal Ready (DTR) from the printer on this conductor. If DTR from the serial printer has not been on since the video terminal was powered up or reset, the ignores all print requests. Once DTR from the serial printer is on, this signal is used to indicate printer status. If DTR is turned off, it is assumed that the printer can not receive characters. When DTR is turned on again, the the print operation is completed.

NOTE: The printer's DTR signal has a higher priority than XON/XOFF control characters. The OFF condition of the printer's DTR stops data transmission even if the printer interface option receives XON. When the printer's DTR signal goes from OFF to ON it is assumed that the XON condition is indicated.

Table 7-15 Printer Interface Signals (Cont)

PIN NAME	MNEMONIC CCITT/ EIA	DESCRIPTION
7 Signal Ground	SGND	102/AB This conductor is the common ground reference for all voltages on the interface.
20 Data Terminal Ready DTR	108.2/CD	FROM VT131 This signal is ON when the terminal is on. The Data Terminal Ready signal is usually received by the printer as Data Set Ready. This signal is generally required by the printer before operation can begin.

CHAPTER 8 INSTALLATION

GENERAL

This chapter contains the information needed to unpack, pack, and install the VT131 terminal. The installation procedure describes how to select the proper input voltage selection and fuse for either 120 or 220 -- 240 VAC operation. A step-by-step power up and checkout procedure is provided.

SITE CONSIDERATIONS

The VT131 terminal is a video monitor and a detachable keyboard. Their dimensions are shown in Figure 8-1. Table 8-1 lists the environmental and power specifications of the terminal.

NOTE: When installing the terminal, make sure that all power and signal cables are free from any stress, sharp bends, or obstructions. Also, be sure to provide access to the monitor controls on the back of the terminal.

Do not block the air flow around the terminal. There are several ventilation openings to prevent the terminal from overheating. Do not block these openings by placing objects on top or under the terminal. Also, do not allow liquids, coins, paper clips, and other objects to enter these ventilation openings. These objects may damage the terminal. For this reason, do not put drinks or metal objects on top of the terminal.

The terminal may be placed on a desk or table top. However, people usually prefer the keyboard at standard typewriter table height rather than desk height. Terminal tables and stands are available from DIGITAL Accessories and Supplies Group. (Refer to Chapter 11 for more information on Accessories.)

Position the terminal to avoid reflected light. The terminal should be facing away from light sources that reflect off the screen. However, if reflected light is a problem, non-reflective and anti-glare screens are available from DIGITAL Accessories and Supplies Group.

For installations that may have static electricity problems, static mats are available from DIGITAL Accessories and Supplies Group .

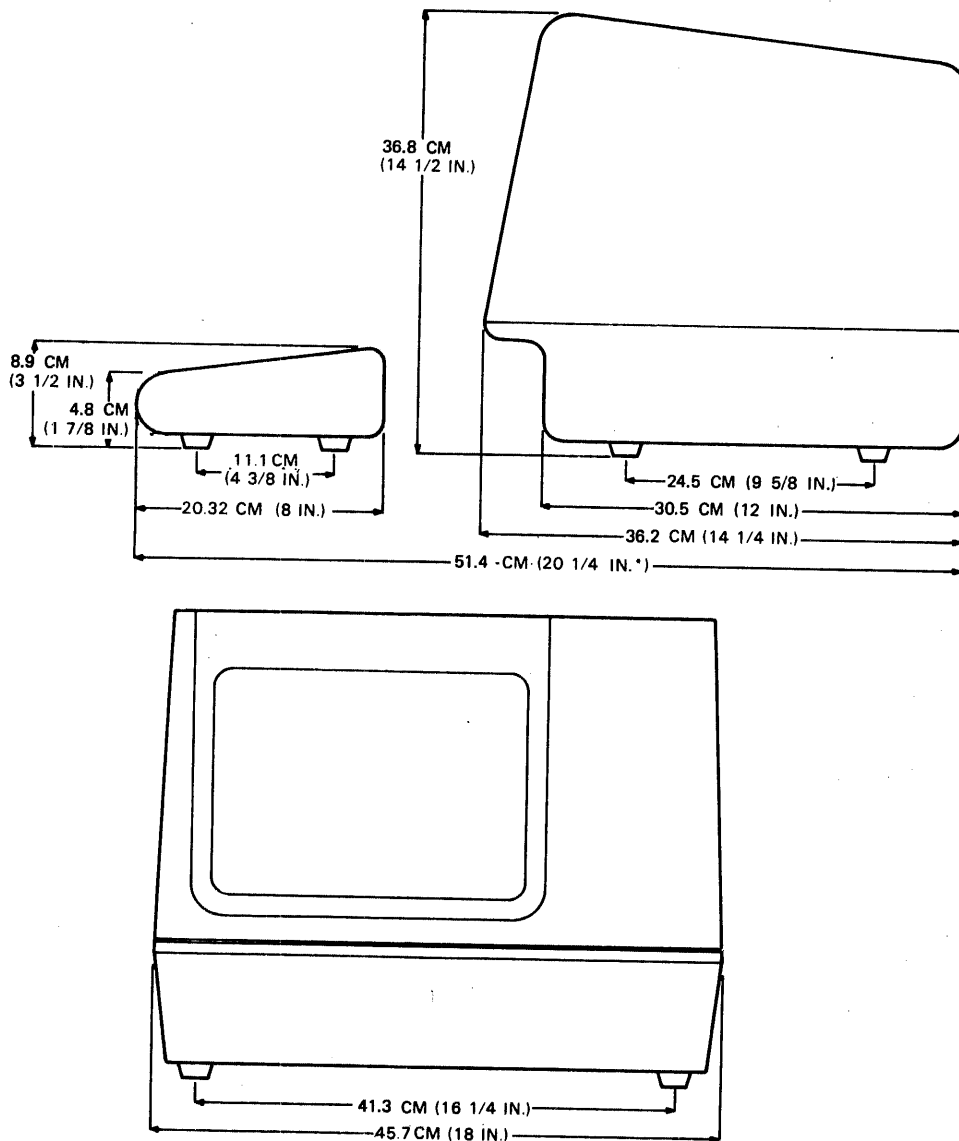

* MEASUREMENT TAKEN WITH THE KEYBOARD PLACED FLUSH TO FRONT OF TERMINAL UNDER UNDERCUT.

MA-1991

Figure 8-1 Terminal Dimensions

Table 8-1 Site Considerations

Site Consideration	Specification
Temperature	100 to 400 C (500 to 1040 F)
Relative Humidity	10 to 90 percent with a maximum wet bulb temperature of 280 C (820 F) and a maximum dew point of 20 C (360 F) noncondensing
Input Voltage	99 to 128 VAC 198 to 256 VAC (switch selectable)
Power Consumption	70 watts
Power Receptacle	Nonswitched, grounded

UNPACKING AND INSPECTION PROCEDURE

The VT131 terminal is packed in a carton containing the following items:

- Monitor
- Keyboard
- AC Power Cord(s)
- SET-UP Label
- User Guide
- Programming Reference Card

Figure 8-2 shows the packaging used with the VT131 terminal. Unpack the terminal from the shipping carton using the following procedure.

1. Cut the carton sealing tape and open the carton flaps.
2. Lift the non-U.S. power cord out of the carton. The non-U.S. power cord is supplied with some variations of the terminal. All terminals are shipped with a U.S. power cord.
3. Lift the terminal out of the carton using the handles provided in the packing material. Place the terminal and packing on its left side (when facing the front of the terminal).
4. Remove the right side packing material.
5. Remove the keyboard and keyboard cover, and then the monitor from the left side packing material.
6. Remove the plastic bags covering the monitor and keyboard.
7. Inspect the terminal for damage.

NOTE: If damaged, notify the carrier and your local DIGITAL Sales Office.

8. Install the terminal using the installation procedure in this chapter.

PACKING PROCEDURE

Packing the VT131 terminal for shipment using the following procedure. (Refer to Figure 8-3 for switch and cable locations.)

1. Turn the power switch off.
2. Disconnect all cables at the back of the terminal.
3. Place the monitor and keyboard in plastic bags.

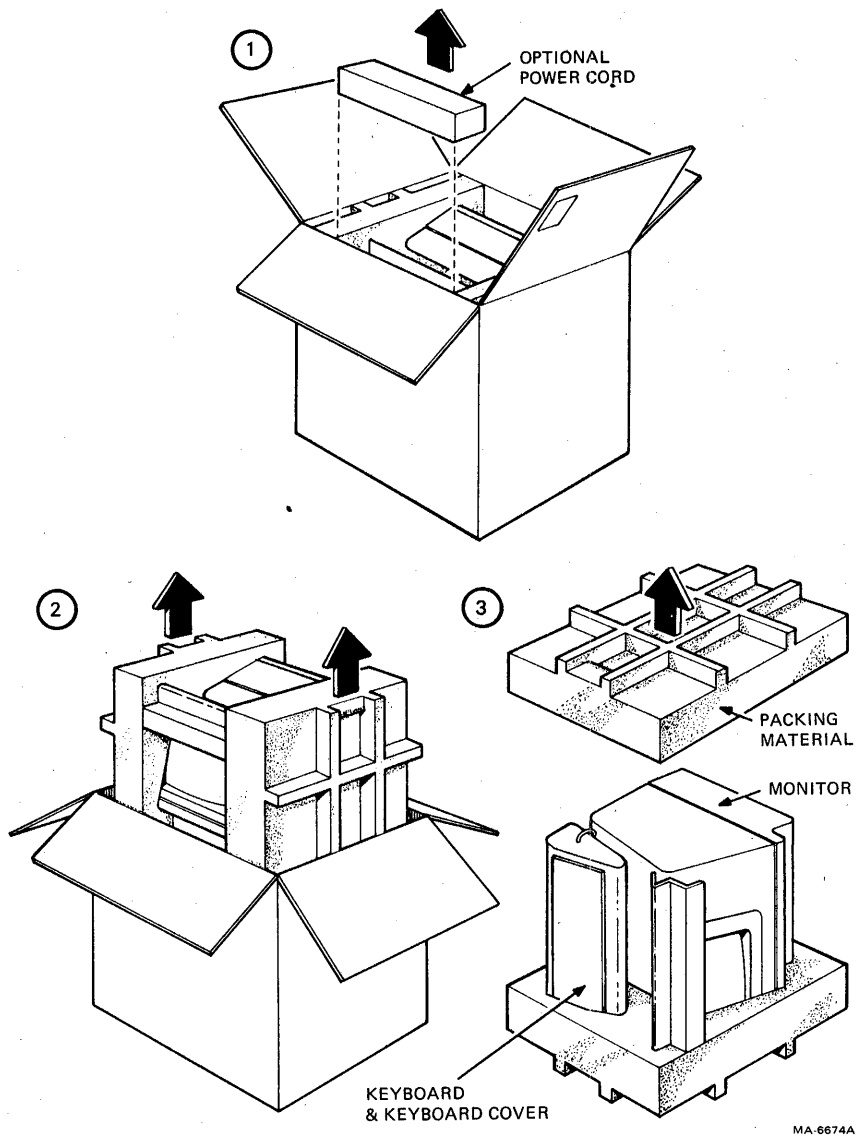
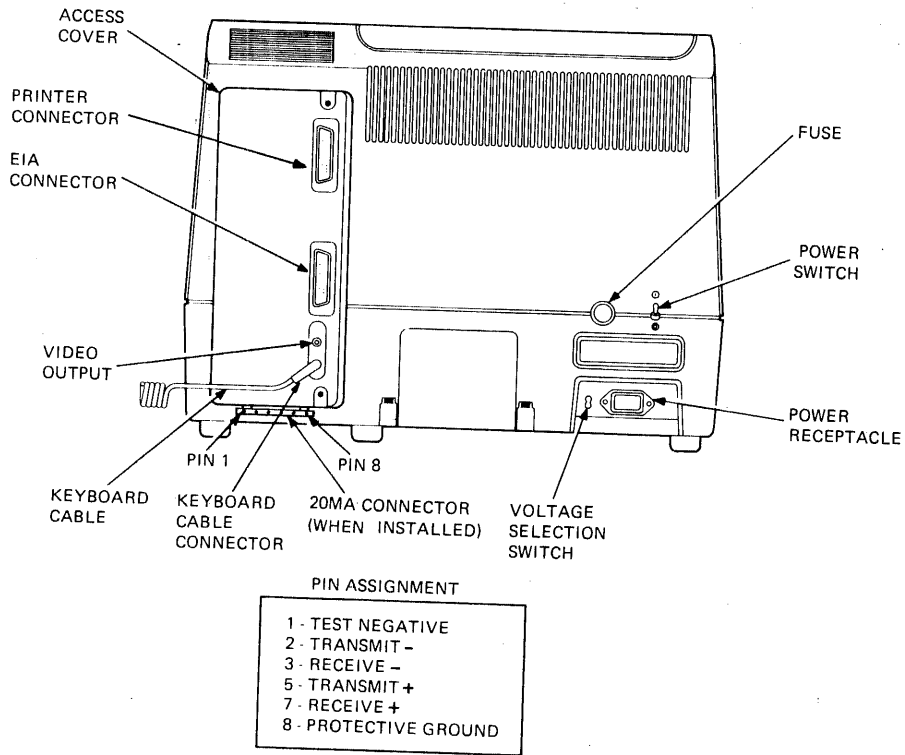

Figure 8-2 Terminal Packing



MA-6675G

Figure 8-3 Monitor Controls and Connector Locations

4. Place the left side packing material (when facing the front of the terminal) on a flat work surface with the cutouts facing up. Place the monitor into the large cutout (Figure 8-2).
5. Route the keyboard cable behind the keyboard to the left side of the keyboard. Place the connector in the small cutout.
6. Place the keyboard cover over the keys of the keyboard and then place the keyboard into the small cutout.
7. Place the right side packing material over the monitor and keyboard.
8. Place the packaged terminal and power cable into the shipping carton, fold the carton flaps and close the carton with sealing tape.

INSTALLATION PROCEDURE

The VT131 terminal can be installed using a 3 mm (1/8 in) blade screwdriver. More tools may be needed when installing any accessories or options. Install the VT131 terminal using the following procedure. (Refer to Figure 8-3 for the switch and cable locations.)

1. Perform the unpacking and inspection procedure described in this chapter.
2. Check the terminal for the proper voltage range selection. The terminal can operate with either 120 volt or 220 -- 240 volt input power. A label over the power receptacle of the terminal indicates the factory selected input voltage range. Check this label, the voltage selection switch, and fuse to be sure that the voltage range of the terminal is the same as your local ac power source. Refer to the Input Voltage Range Selection section of this chapter when selecting the input voltage range.

CAUTION: Failure to select the proper voltage range will damage the terminal.

3. Select the internal communication switches of the terminal. Refer to the Communication Switch Selection section of this chapter when selecting the communication switches.
4. If needed, install the 20 mA current loop option (VT1XX-CA). Perform the option installation and option checkout procedures in Chapter 9.
5. Attach the SET-UP label to the bottom of the keyboard. Remove the backing paper in order to use the self-sticking SET-UP label.

6. Place the keyboard in front of the terminal and plug the keyboard into the keyboard connector located at the back of the terminal.
7. Connect the printer cable to the printer interface connector. Fasten the connector to the terminal with the captive screws of the cable using a 3 mm (1/8 in) blade screwdriver. Refer to the Cable Summary section of this chapter for more information about cables. Refer to Chapter 7 for information about connector use and signal/pin definitions.
8. If using the modem interface connector, connect the communication cable connector to the terminal. Fasten the connector to the terminal with the captive screws of the cable using a 3 mm (1/8 in) blade screwdriver. Refer to the Cable Summary section of this chapter for more information about cables. Refer to Chapter 7 for information about connector use and signal/pin definitions.
9. In addition to the communication interface, the terminal is also capable of connecting to an external device using the video output connector. The video output connector is a BNC connector located at the back of the terminal. Use a 75 ohm video cable to connect the terminal to the external device. Detailed specifications for the output signal are in Appendix A.
10. Connect one end of the ac power cable to the terminal and the other end to a nonswitched, grounded receptacle.

NOTE: Check to be sure the power switch is in the off (0) position before connecting the power cord.

11. Perform the power up and checkout procedure in this chapter.

Input Voltage Range Selection

The VT131 terminal can be used with ac input voltage range of 99-128 or 198-256 volts. Both the voltage selection switch position and the fuse must be changed when selecting the input voltage range.

To use the terminal with 120 volts, perform the following procedure.

1. With the power switch off, set the voltage selection switch to 120 (operating range 99 -- 128 volts).
2. Remove the fuse holder cap by pressing it in and turning it counter-clockwise (Figure 8-3). Check for a 1.25 ampere fuse (DIGITAL part number 9000020-01). Replace the fuse and fuse holder cap by pressing it in and turning it clockwise.

To use this terminal with 220 -- 240 volts, perform the following procedure.

1. With the power switch off, set the voltage selection switch to 240 (operating range 198 -- 256 volts).
2. Remove the fuse holder cap by pressing it in and turning it counter-clockwise (Figure 8-3). Check for a 0.75 ampere slow blow fuse (DIGITAL part number 1211237-00). Replace the fuse and fuse holder cap by pressing it in and turning it clockwise.

Internal Communication Switch Selection

The VT131 terminal has ten communication switches mounted within the terminal. These switches connect or disconnect ten modem communication lines. For more information on the use of these communication lines refer to Chapter 7. Use the following procedure to select these switches.

1. With the power switch off, loosen the two captive screws holding the access cover in place (Figure 8-4).
2. Pull the access cover straight out the back of the terminal. When the access cover is loose, move it to the left to avoid the studs within the terminal. Continue to pull the access cover out straight (Figure 8-5).
3. Select the communication switches. The VT131 terminal uses one communication switch pack. However, there are three types of switch packs that may be used in the terminal: two types use rocker switches and one type uses slide switches. To select a switch setting using the rocker type switch, press the side of the switch which corresponds to the desired selection. To select a switch setting using the slide type switch, push the switch tab to the side that corresponds to the desired setting. Figure 8-6 shows the location of the communication switches. Figure 8-7 shows the communication lines connected (on, closed) or disconnected (off, open) by the communication switches.

NOTE: Always use a small blade screwdriver or ball point pen to change the communication switches. Never use a lead pencil.

4. Install the access cover.

CAUTION: The access cover may be damaged if the captive screws are tightened too much.

Communication and Printer Cable Selection

Communications and printer cables for the terminal can be ordered from the DIGITAL Accessories and Supplies Group. Part numbers and ordering information for these cables is supplied in Chapter 11. Table 8-2 describes each communication cable used and Figure 8-8 shows connection examples for each cable.

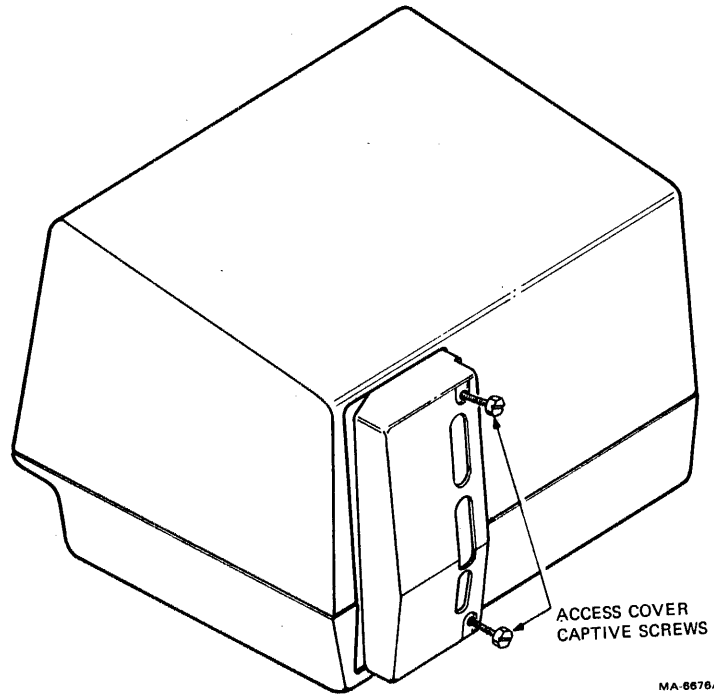

MA-6678A

Figure 8-4 Access Cover Screw Locations

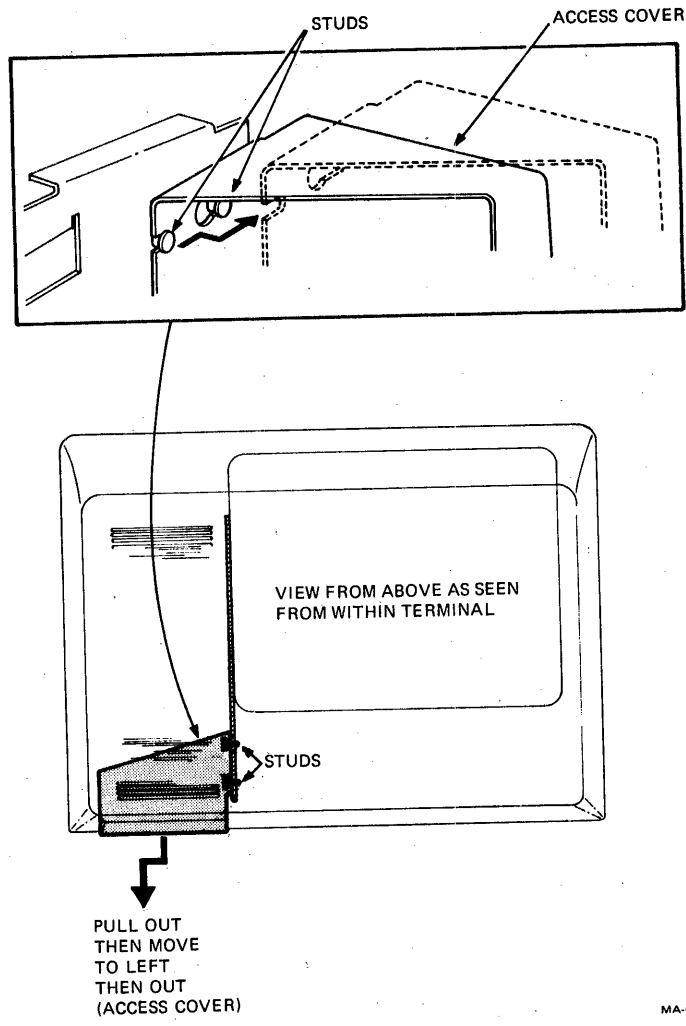

MA-6668

Figure 8-5 Access Cover Removal

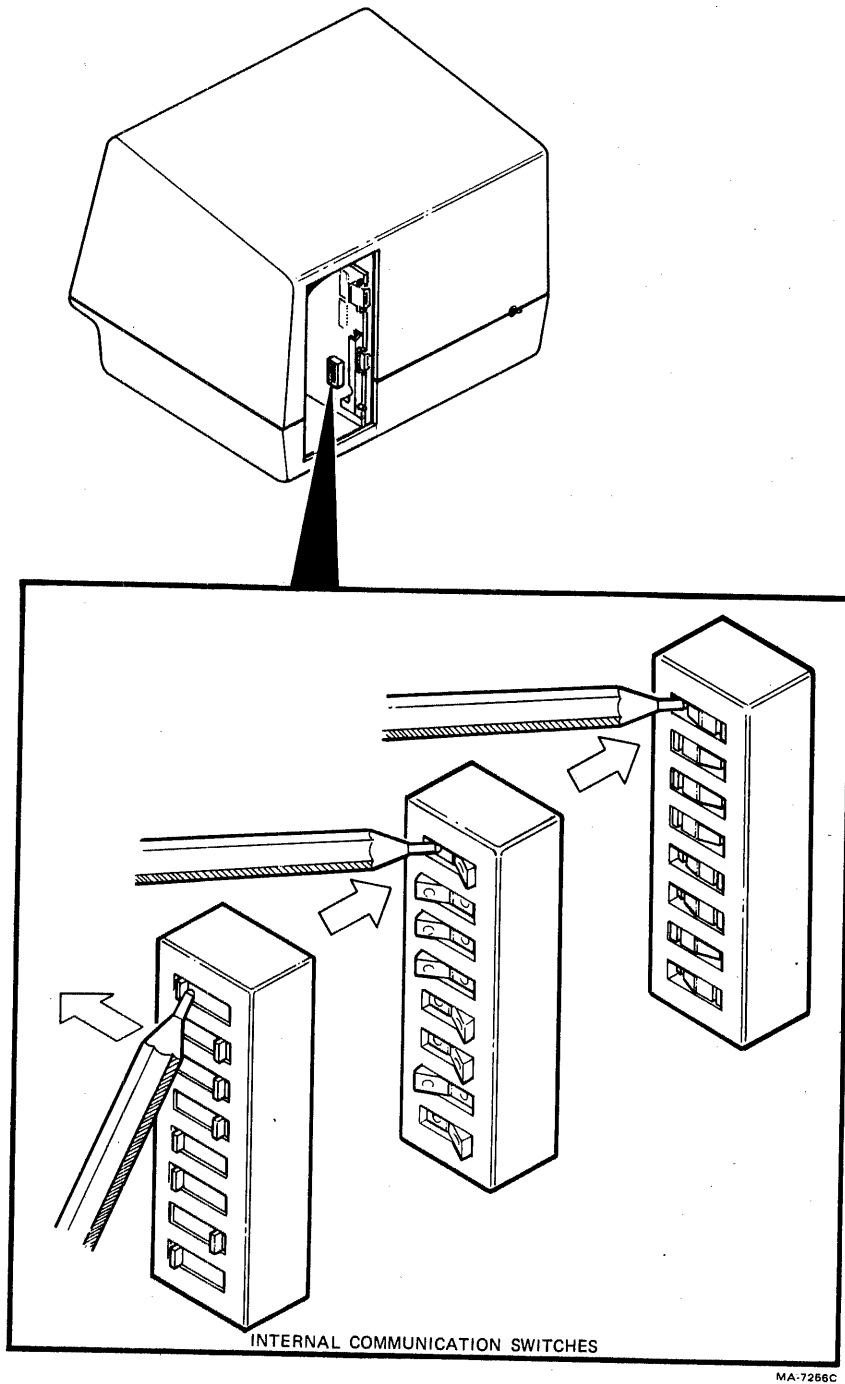
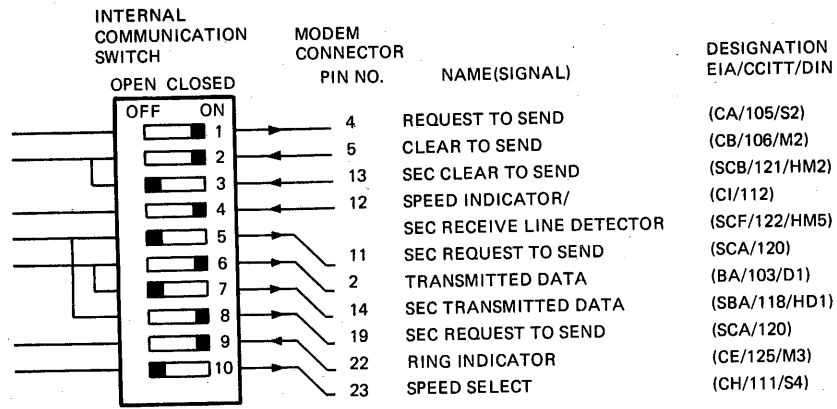

Figure 8-6 Internal Communication Switch Locations



MA-9361

Figure 8-7 Internal Communication Switch Selections

Table 8-2 Interface Cables

Number	Length	Connector Types	Function
BC22A-10	10 ft	RS-232 (female) to RS-232 (female)	Null modem; direct connection between VT102 and computer or printer (6-conductor cable).
BC22A-25	25 ft	RS-232 (female) to RS-232 (female)	Null modem; direct connection between VT102 and computer or printer (6-conductor cable).
BC22B-10	10 ft	RS-232 (male) to RS-232 (female)	Extension; connects VT102 to a modem (14-conductor cable).
BC22B-25	25 ft	RS-232 (male) to RS-232 (female)	Extension; connects VT102 to a modem (14-conductor cable).
BC03M-xx	variable	RS-232 (female) to RS-232 (female)	Null modem; direct connection between VT102 and computer or printer.
BC05D-xx	variable	RS-232 (male) to RS-232 (female)	Extension; connects VT102 to a modem.
BC05F-xx	variable	Mate-N-Lok (male) to Mate-N-Lok (male)	20 mA; direct connection between VT102 with a 20 mA option installed and a computer. (Supplied with 20 mA option.)
BC05X-xx	variable	Mate-N-Lok (female) to Mate-N-Lok (male)	20 mA extension cable.
30-10958-02	EIA: 18 in 20 mA: 8 ft	RS-232 (male) to RS-232 (female) and 20 mA (male)	Connection between Acoustic Coupler and VT102 EIA or 20 mA.

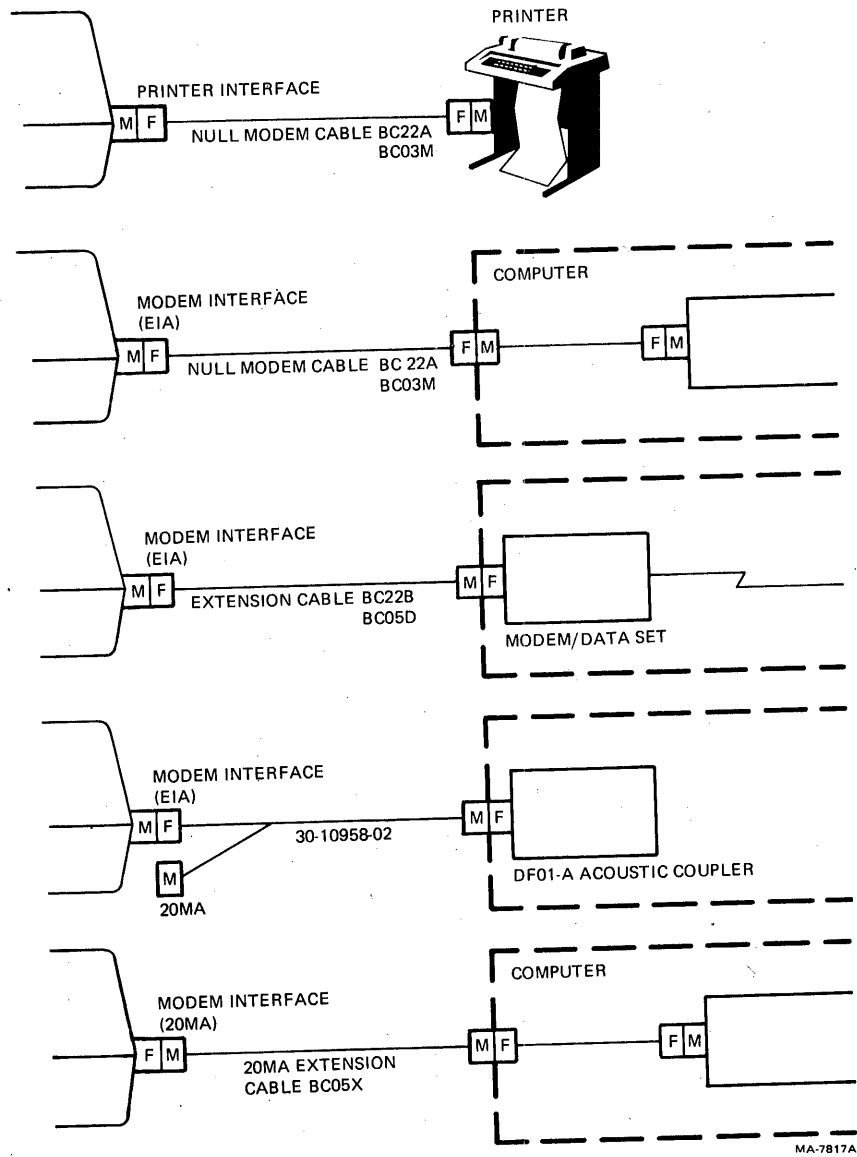

Figure 8-8 Cable Summary

POWER UP AND CHECKOUT PROCEDURE

A power up self-test is used to verify the proper operation of the VT131 terminal each time the terminal is powered up. Perform the following procedure to power up and checkout the terminal.

1. Turn the power switch to the on position (Figure 8-3). The terminal automatically runs the power up self-test. The test provides the following indications.

^ Test data is displayed, the Wait message is displayed on the screen and then is erased. (The test data and wait message are not visible if the terminal has not warmed up.)

^ All keyboard indicators turn on and off, and either the ON LINE or OFF LINE indicator is turned on. The other indicators may be either on or off depending on feature selections and modem signals on the modem interface.

^ A bell tone is generated.

^ The cursor is display in the upper-left corner of the screen.

Any error found by the power up self-test is indicated by: the terminal not performing the above sequence, a character displayed at the cursor position, or by several bell tones. Refer to Chapter 10 for troubleshooting information if the terminal does not power up correctly.

2. Verify that the power up self-test has been completed successfully by entering SET-UP. A SET-UP display is shown on the screen if the terminal has successfully completed the power up test. If a SET-UP display is not shown on the screen, call your local DIGITAL Field Service Office.
3. If the terminal powers up correctly, select the SET-UP features as described in Chapter 4.
4. When the SET-UP features are selected, record the feature selections on the SET-UP label attached to the bottom of the keyboard.
5. Save the SET-UP features using the SHIFT and S key sequence. Refer to Chapter 4 for more information about saving SET-UP features.

GENERAL

The VT131 terminal uses the (VT1XX-CA) 20 mA current loop option. This chapter describes the 20 mA Current Loop interface option, its installation and checkout. Refer to Chapter 11 for 20 mA option ordering information.

20 mA Current Loop Interface Option (VT1XX-CA)

The 20 mA Current Loop Option is an interface that connects the VT131 terminal to a computer. The 20 mA option is a board and a modem interface connector installed within the terminal. When this option is installed the modem control SET-UP feature must be selected to FDX A, full duplex with no modem control (data leads only) operation. The internal communication switches are not used when the 20 mA option is installed. Figure 9-1 shows the 20 mA current loop interface connector and pin assignments.

NOTE: The VT131 terminal uses either 20 mA or EIA communications. If EIA is used on a terminal with a 20 mA option, the cable connecting the 20 mA option board to the terminal controller board must be disconnected.

OPTION INSTALLATION

The VT1XX-CA current loop option is installed using the following tools.

- #2 Phillips screwdriver
- 5 mm (3/16 inch) blade screwdriver
- 1/4 inch nutdriver (optional)
- 8 mm (5/16 inch) nutdriver (optional)

Use the following procedure to install the 20 mA Current Loop Option.

1. Turn the power switch off (Figure 9-1).
2. Unplug the power cord, the keyboard and any cables connected to the printer connector and composite video output connector.

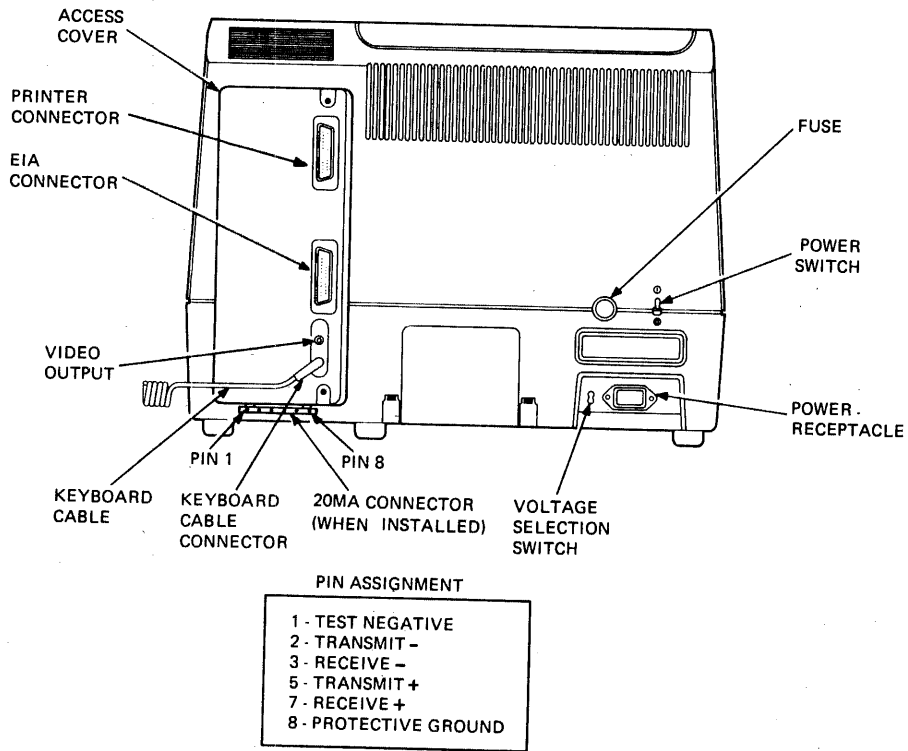

MA-6675G

Figure 9-1 20 mA Connector and Pin Locations

3. Disconnect the communications cable, if installed.
4. Loosen the two captive screws holding the access cover in place (Figure 9-2). There are two types of captive screws used on the access cover, Phillips head or slotted hexagonal (hex) head. Therefore, either a Phillips screwdriver or blade screwdriver/8 mm (5/16 inch) nutdriver can be used.
5. Pull the access cover straight out the back of the terminal. When the access cover is loose, move it to the left to avoid the studs in the terminal. Then continue to pull the access cover straight out (Figure 9-3).
6. Install the 20 mA current loop option board onto the access cover using the three Phillips head screws provided using the Phillips screwdriver (Figure 9-4).
7. Install the 20 mA communications connector to the bottom of the access cover using the two spacers and two hex head screws provided. Use the blade screwdriver or 1/4 inch nutdriver to tighten the screws.
8. Install the 20 mA loopback connector to a spacer holding the 20 mA communication connector. This is done to prevent the loss of the test connector.
9. Select TRANSMit and RECEive switches to the proper configuration (Figure 9-5). The switches determine if the transmitter and receiver of the 20 mA interface board are active and normal (passive). Typically, the terminal is connected using normal (passive). Passive means that the terminal does not supply the 20 mA current used when communicating. Active means that the terminal supplies the 20 mA current used when communicating.

NOTE: These switches must be selected for NORMAL (passive) to perform the loopback test. The loopback test is used to verify proper operation of the option after installation.

10. Connect the adaptor cable provided with the option to the 20 mA board (Figure 9-5). Place the access cover next to the opening in the back of the terminal and connect the other end of the adaptor cable to the connector on the terminal controller board.
11. Holding the access cover straight up, move it to the right side of the opening in the terminal. Push the access cover into the back of the terminal, feeling for the studs in the terminal. Figure 9-3 shows how the access cover fits on the studs as seen inside the terminal.
12. Tighten the two captive screws to hold the access cover in place (Figure 9-2).

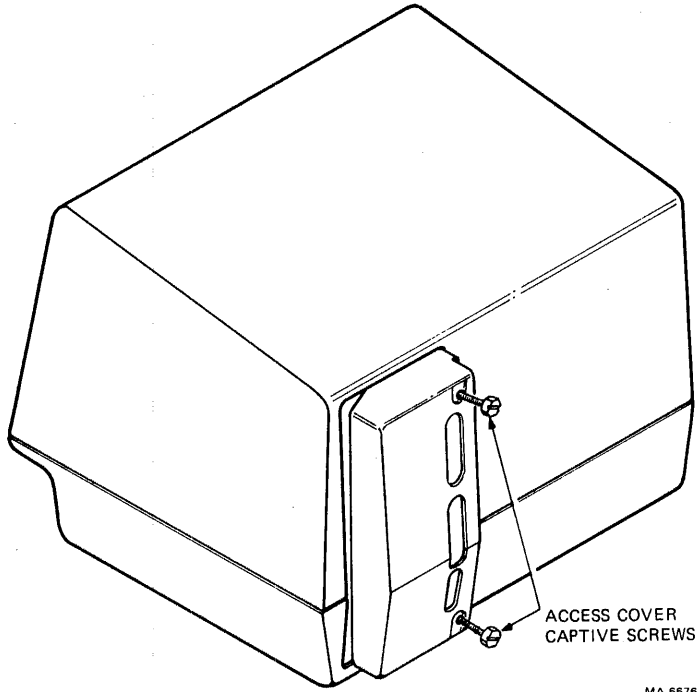

Figure 9-2 Access Cover Screw Locations

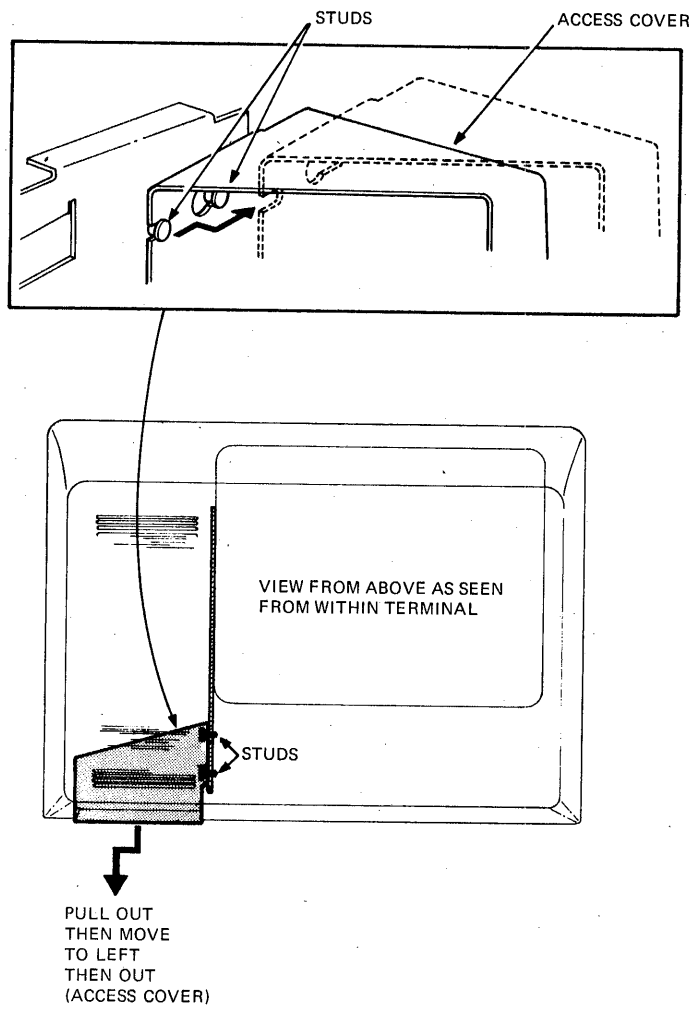

Figure 9-3 Access Cover Removal

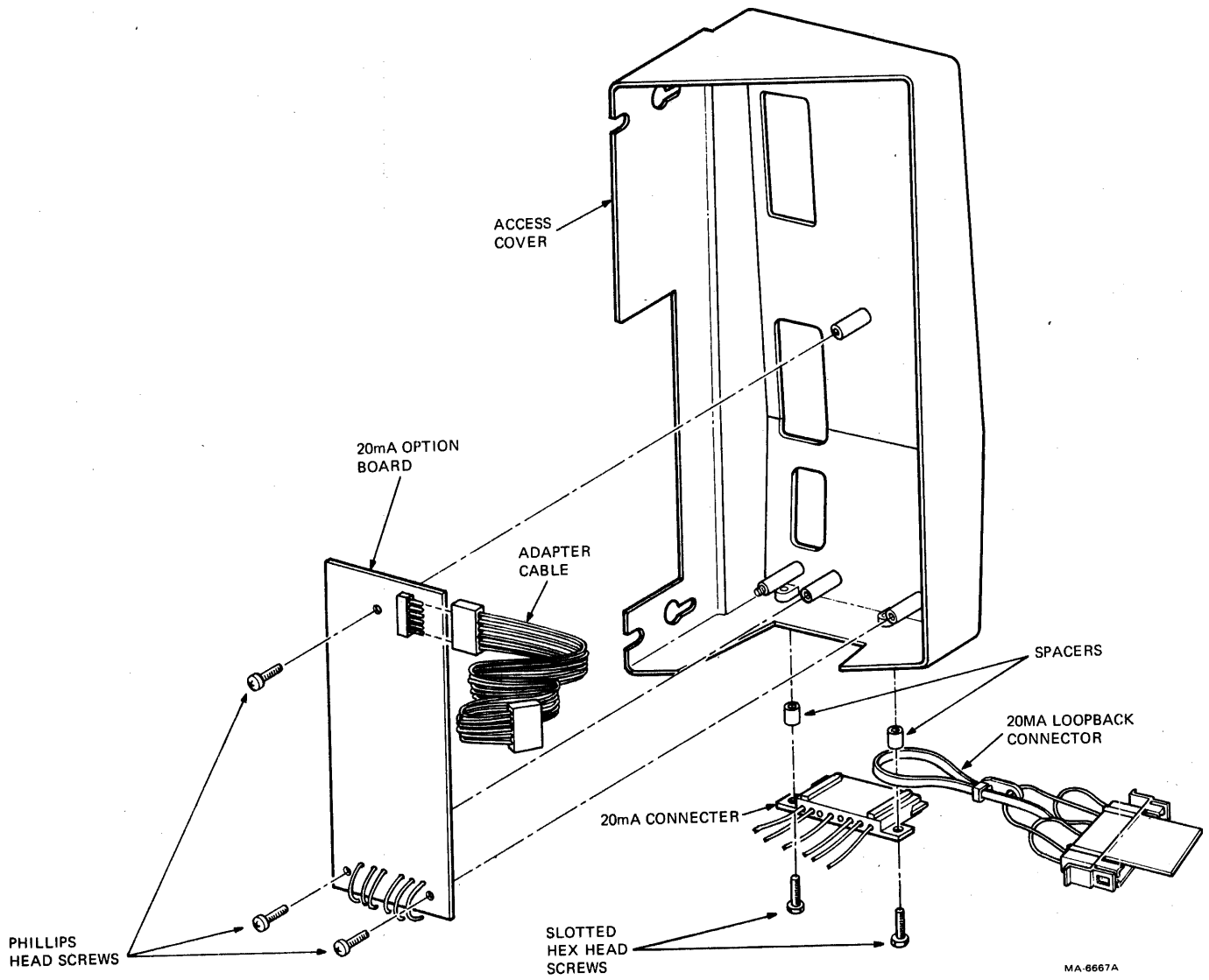
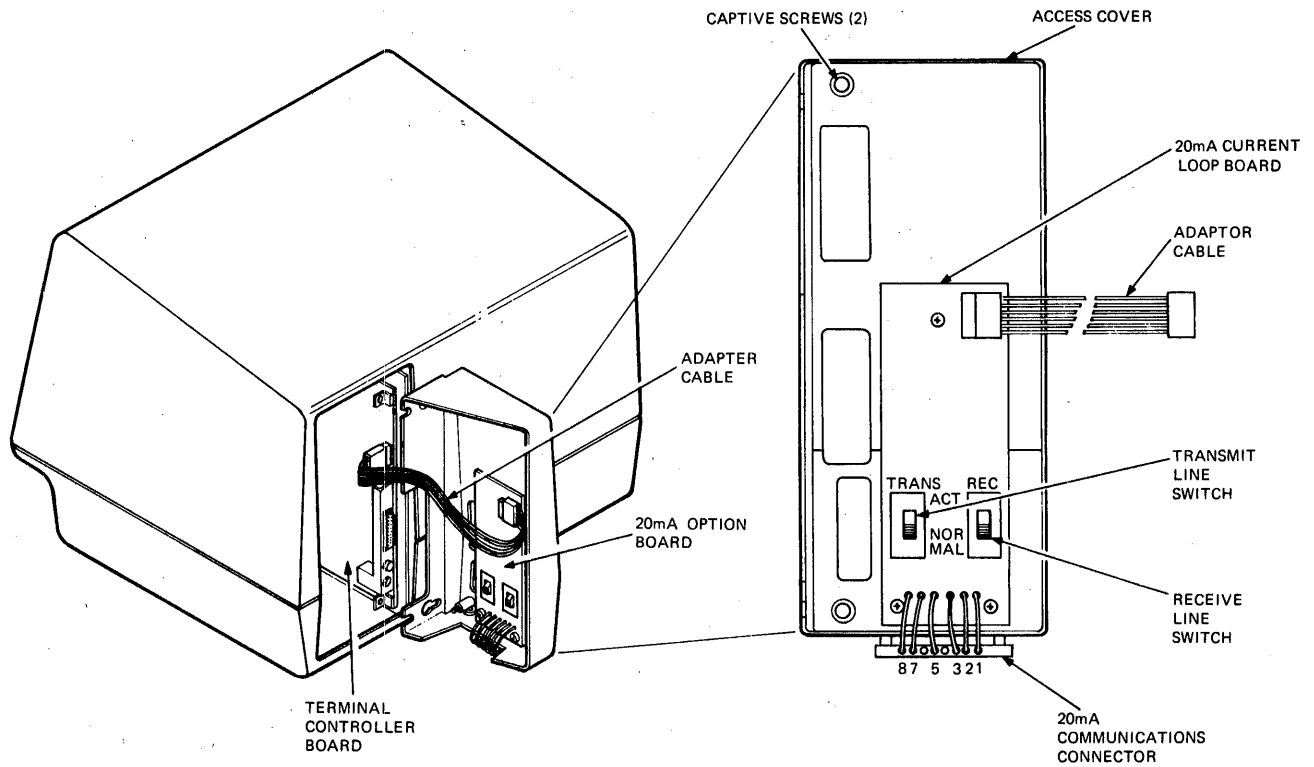

Figure 9-4 20 mA Board Location



MA-6656A

Figure 9-5 20 mA Board Configuration

CAUTION: The access cover may be damage if the captive screws are tightened too much.

13. Perform the data loopback self test described in the Option Checkout section of this chapter.

OPTION CHECKOUT

The data loopback test verifies the 20 mA current loop option can transmit and receive characters. In the data loopback test, characters transmitted during the test are sent through the loopback connector back to the terminal. The test checks these characters to be sure the option is operating correctly. Perform the data loopback self test using the following procedure.

1. Turn the power switch off (Figure 9-1).
2. Unplug the power cord, the keyboard and any cables connected to the printer connector and composite video output connector.
3. Disconnect the communications cable (if installed) and install the loopback connector on the 20 mA connector (Figure 9-6). The 20 mA loopback connector part number is 70-15503-00 and is supplied with the option.

NOTE: The access cover is not removed if the transmit and receive switches of the 20 mA option are selected to NORMAL. Therefore, if the switches are selected to NORMAL, do not perform steps 4, 5 and 6.

4. Loosen the two captive screws holding the access cover in place (Figure 9-2). There are two types of captive screws used on the access cover, Phillips head or slotted hexagonal (hex) head. Therefore, either a Phillips screwdriver or blade screwdriver/8 mm (5/16 inch) nutdriver can be used.
5. Pull the access cover straight out the back of the terminal. When the access cover is loose, move it to the left to avoid the studs in the terminal. Then continue to pull the access cover straight out (Figure 9-3).
6. Set both 20 mA current loop option switches to the NORMAL position (Figure 9-5) and install the access cover (Figure 9-3).

CAUTION: The access cover may be damage if the captive screws are tightened too much.

7. Connect the keyboard cable and power up the terminal. The terminal performs the power up self test.

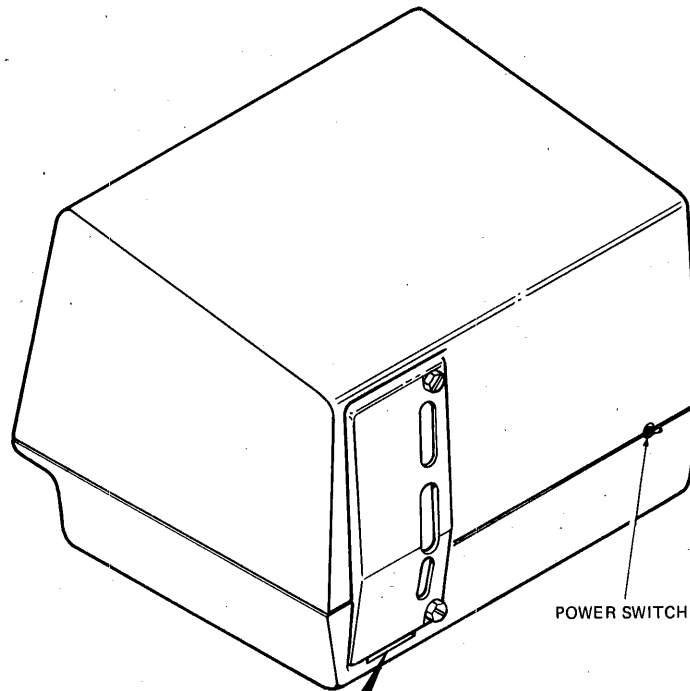

POWER SWITCH

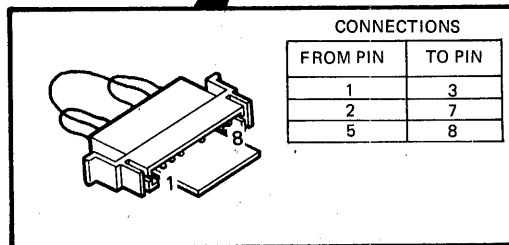

MA-7867B

Figure 9-6 20 mA Loopback Connector

8. Enter SET-UP and select:
- ^ off-line (therefore, the transmit and receive speeds do not have to be the same)
 - ^ ANSI/VT52 SET-UP feature to ANSI (SET-UP B switch 2-3 = 1)
 - ^ Modem control SET-UP feature to FDX A
9. Start the data loopback self test using one of the following sequences.

ESC [2 ; 2 y Performs the data loopback self test once.

ESC [2 ; 10 y Performs the data loopback self test continuously.

NOTE: The wait message is displayed on the screen while the test is being performed. The continuously running tests end only if an error is found or if power is turned off.

The test ends with the following indications:

- ^ The wait message is erased from the screen.
- ^ Either the ON LINE or OFF LINE indicator is on.
- ^ The cursor is displayed in the upper-left corner of the screen.

Any error found by the test displays an error code on the screen. If an error is found, the option is not operating correctly. Call your local Digital Field Service Office for assistance.

10. Turn the power switch off and remove the loopback connector.
11. If the terminal does not use the normal (passive) switch setting on the 20 mA board, disconnect the keyboard cable and remove the access cover and select the proper switch selections. Install the access cover and connect the keyboard, communication, printer and video output cables.

GENERAL

This chapter describes maintenance procedures, troubleshooting (what to do in the event of a problem) and self-tests used with the VT131 terminal. Troubleshooting should be performed before requesting service.

MAINTENANCE

The VT131 terminal needs no preventive maintenance. However, the surfaces may be cleaned with any mild detergent that does not use solvents. To clean the surfaces of the terminal or screen, apply the detergent to a cloth or tissue and then clean. To clean the keys, rub with a dry or moist cloth.

CAUTION: Do not use too much detergent when cleaning the terminal. If liquids get inside the terminal, the terminal may be damaged. Do not remove the keycaps when cleaning; the keyswitch contacts can be damaged if the keycaps are replaced incorrectly.

TROUBLESHOOTING

If the terminal appears not to be operating correctly, first refer to Table 10-1 to see if the symptoms are there. If the problem is not listed in Table 10-1, use the following procedure.

1. Turn the power switch off and check (Figure 10-1):
 - a. The power cord -- make sure the cord is connected securely at both the terminal and at the wall outlet. Check the wall outlet with another device such as a lamp to be sure that it is providing ac power.
 - b. The voltage selection switch and fuse -- make sure the switch is in the correct position. To use the terminal with 115 volts:
 - ^ Set the voltage selection switch to 115 (operating voltage range 99 to 128 volts).
 - ^ Remove the fuse holder cap by pressing it in and turning it counter-clockwise. Check for a 1.25 ampere fuse (DEC part number 900020-01) and be sure the wire in the fuse is not broken.

Table 10-1 Problem Checklist

Symptom	Possible Cause	Corrective Action
ON LINE or OFF LINE indicator on with no cursor on screen.	Screen Brightness too low.	Enter SET-UP and increase the screen brightness.
ON LINE or OFF LINE indicators not on with no keyboard response. Cursor on screen.	Keyboard cable not connected to terminal	Connect keyboard cable
KBD LOCKED indicator is on.	Characters are being typed into the terminal faster than they can be transmitted.	Turned off when the characters in the keyboard character buffer are transmitted to the computer.
	When half duplex communication is selected (by the modem control SET-UP feature) the locked condition occurs whenever the terminal is receiving characters. The terminal can not transmit characters when receiving characters in half duplex.	Turned off when the line is turned around and the terminal can transmit the keyboard characters.
	When a print operation is selected while off-line.	Turned off when the print operation is completed.
	The terminal is not properly connected to the computer. The communication line signals are not correct for communication.	Turned off when a proper connection exists between the computer and terminal.
	The computer has turned the keyboard off.	Turned off when the computer turns on keyboard.
	The terminal is transmitting while in edit mode.	Turns off when the transmission is complete.

Table 10-1 Problem Checklist (Cont)

Symptom	Possible Cause	Corrective Action
Terminal does not respond to typed characters. Keyclicks generated and keyboard indicators function.	Screen can not be updated by the Computer. Due to the XOFF control character or a print operation that can not be completed.	Press the NO SCROLL key. Enter and Exit SET-UP.
Garbled or Error (D) Characters or no characters appearing on the screen.	Incorrect SET-UP feature selection computer error	Correct the SET-UP features. check computer system.
Two Characters appearing on screen for each character typed.	Local Echo feature on.	Turn off feature.
Several bell tones during power up, Reset or Recall.	Read or write problem with user permanent memory.	Check the SET-UP feature settings and try the Save operation.
Printer will not print characters from VT131 terminal.	Printer and VT131 features do not match.	Check the SET-UP feature settings of the VT131 terminal. Check the feature settings of the printer and ensure that the printer can operate.

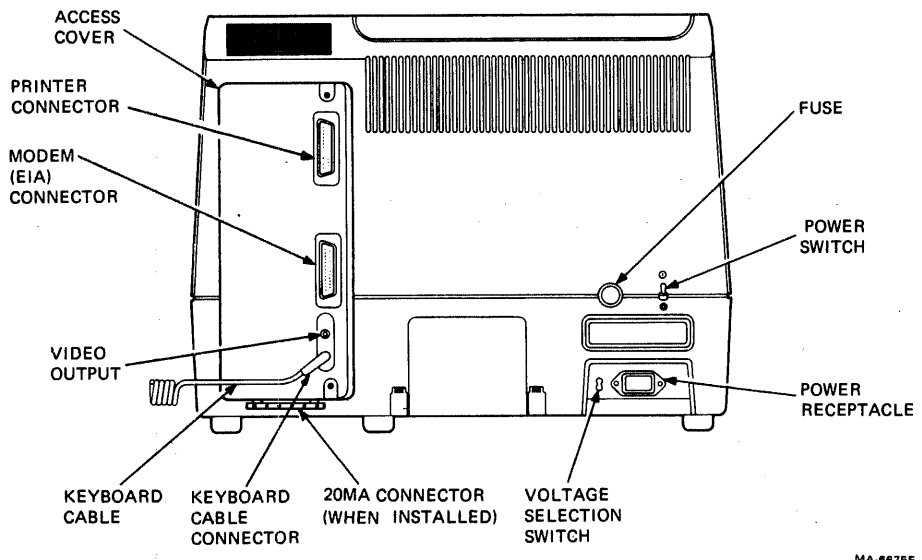

MA-6675E

Figure 10-1 Monitor Controls and Connector Locations

To use the terminal with 220/240 volts:

- ^ Set the voltage selection switch to 220 (operating voltage range 198 to 256 volts).
 - ^ Remove the fuse holder cap by pressing it in and turning it counter-clockwise. Check for a 0.75 ampere slow blow fuse (DEC part number 1211237-00) and be sure the wire in the fuse is not broken.
 - c. Keyboard Coiled Cord -- make sure that the cord is securely plugged into the keyboard connector at the back of the terminal.
2. Perform the power up self-test. (Refer to the power up self-test description in this chapter for more information about using this test.)

NOTE: The following tests use an optional loopback connector. This connector can be order from DIGITAL Accessories and Supplies.

3. Perform the data loopback self-test. (Refer to the data loopback description in this chapter for more information about using this test.)
4. Perform the EIA loopback self-test. (Refer to the EIA loopback description in this chapter for more information about using this test.)
5. Perform the printer loopback self-test. (Refer to the printer loopback description in this chapter for more information about this test.)
6. Perform the printer test. (refer to the printer test description in this chapter for more information about this test.)

SELF-TESTS

The VT131 terminal uses self-tests to verify proper operation. The self-tests provided are: a power up self-test, three loopback self-tests and a printer test. The power up self-test is performed each time the terminal is powered up. The loopback self-tests may be performed after the power up self-test is completed. The loopback self-tests use an optional loopback test connector. The printer test is used to ensure that the terminal and printer can operate together.

Power Up Self-Test

A power up self-test is built into the VT131 terminal to test the operation of the terminal each time the power is turned on (powered up). The test checks general terminal operation, user memory (holding SET-UP features) and keyboard. Perform the power up self-test using the following procedure.

1. Start the power up self-test in any one of the following ways:
 - ^ Turn the power switch on (Figure 10-1).
 - ^ If power is on, press the SET-UP key and then the RESET key.
 - ^ If power is on type one of the following sequences. The terminal is off-line with the ANSI/VT52 SET-UP feature selected to ANSI (SET-UP B switch 2-3 = 1).

ESC [2 ; 1 y Performs the data loopback self-test once.

ESC [2 ; 9 y Performs the data loopback self-test continuously.

NOTE: The continuously running test ends only if an error is found or if power is turned off.

The test ends with the following indications.

- ^ Test data is displayed, the Wait message is displayed on the screen and then is erased. (The test data and wait message are not visible if the terminal has not warmed up.)
- ^ All keyboard indicators turn on and off, and either the ON LINE or OFF LINE indicator is turned on.

NOTE: The other keyboard indicators may or may not be on depending on the communication signals received on the modem interface connector and the feature selections of the terminal.

- ^ A bell tone is generated.
- ^ The cursor is displayed in the upper-left corner of the screen.

Any error found by the power up self-test is indicated by: the terminal not performing the above sequence, a character displayed at the cursor position, or by several bell tones. There are two failures that allow operation of the terminal to continue. They are: a user memory failure indicated by a 2 on the screen and several bell tones, and a keyboard failure indicated by a 4 on the screen. The user memory failure allows continued operation after the SET-UP features are selected in operating memory. The keyboard failure allows the terminal to continue to operate as a receive only terminal.

2. Verify that the test has been completed successfully by entering SET-UP. If SET-UP A is displayed on the screen, the terminal has successfully completed the power up test. If a SET-UP display is not shown on the screen, call your local DIGITAL Field Service Office for repair.

Data Loopback Self-Test

The data loopback self-test is used to verify that the VT131 terminal can transmit and receive characters. In the data loopback test the transmit and receive lines are connected to each other with an external loopback connector (part number 12-15336). The terminal transmits characters on the transmit line and receives the characters on the receive line. Perform the data loopback self-test using the following procedure.

NOTE: To perform the data loopback test with the 20 mA current loop option (VT1XX-CA) installed, refer to Chapter 9.

1. With the power switch off, disconnect the communication cable and install the loopback connector on the modem connector (Figure 10-2). The loopback connector part number is 12-15336 and is available from DIGITAL Accessories and Supplies Group, refer to Chapter 11.
2. The internal communication switch S6 must be on (closed) to perform this test. If the switch is off (open), remove the access cover, turn switch S6 on (closed) and install the access cover. A detailed procedure to select the communication switches is provided in Chapter 8.

NOTE: This switch is usually only open when the modem control SET-UP feature is selected for asymmetric full duplex (FDX C).

3. Power up the terminal. The terminal performs the power up self-test.
4. Type one of the following sequences to perform the test. The terminal must be off-line with the ANSI/VT52 SET-UP B feature selected to ANSI (SET-UP B switch 2-3 = 1).

ESC [2 ; 2 y	Performs the data loopback self-test once.
ESC [2 ; 10 y	Performs the data loopback self-test continuously.

NOTE: The Wait message is displayed on the screen while the test is being performed. The continuously running test ends only if an error is found or if power is turned off.

The test ends with the following indications:

- ^ The Wait message is erased from the screen.
- ^ The cursor is displayed in the upper-left corner of the screen.
- ^ The ON LINE indicator is turned on.

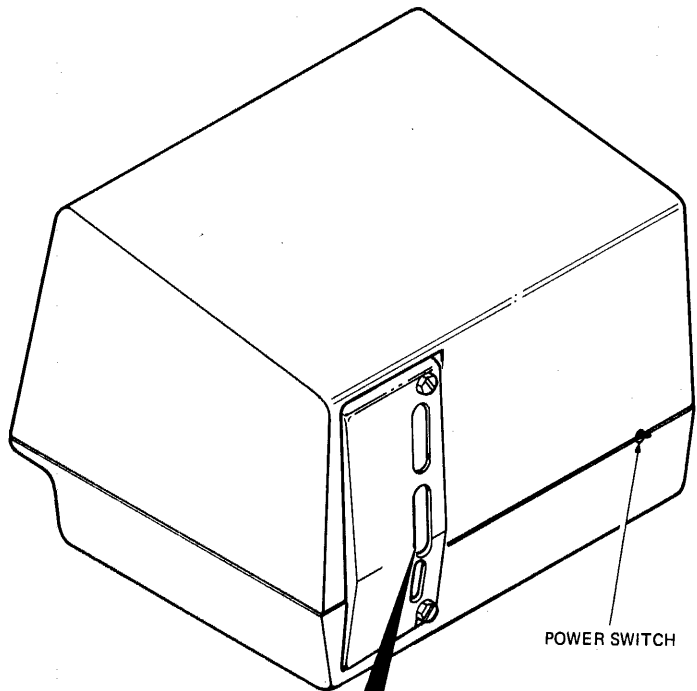

POWER SWITCH

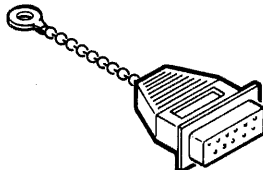

CONNECTIONS		
FROM PIN	TO PIN	TO PIN
2	3	15
4	5	8
20	6	22
19	12	17

MA-7868B

Figure 10-2 EIA Loopback Connector

NOTE: The other keyboard indicators may or may not be on depending on the signals communication signals on the modem connector and the feature selections of the terminal.

Any error found by the data loopback self-test displays an error character on the screen. Call your local DIGITAL Field Service Office whenever self-test errors are found.

5. If the terminal successfully completes the test, turn the power switch off and remove the loopback connector. If switch S6 was changed in step 2 of this procedure, change the switch to its original position. A detailed procedure to select the communication switches is provided in Chapter 8.
6. Connect the communication cable to the terminal.

EIA Loopback Self-Test

The EIA loopback self-test is used to verify that the VT131 terminal can operate its modem control lines. Perform the EIA loopback self-test using the following procedure.

1. With the power switch off, disconnect the communication cable and install the loopback connector on the modem connector, refer to Figure 10-2. The loopback connector part number is 12-15336 and is available from DIGITAL Accessories and Supplies Group, refer to Chapter 11.
2. The internal communication switches S1, S2, S4, S6, S8 and S9 must be on (closed) to perform this test. If any of the switches are off (open), remove the access cover, turn the switches on (closed) and install the access cover. (A detailed procedure to select the communication switches is provided in Chapter 8).
3. Power up the terminal. The terminal performs the power up self-test.
4. When power is on type one of the following sequences to perform the test. The terminal is off-line with the ANSI/VT52 SET-UP B feature selected to ANSI (SET-UP B switch 2-3 = 1).

ESC [2 ; 4 y	Performs the EIA loopback self-test once.
ESC [2 ; 12 y	Performs the EIA loopback self-test continuously.

NOTE: The Wait message is displayed on the screen while the test is being performed. The continuously running test ends only if an error is found or if power is turned off.

The test ends with the following indications:

- ^ The Wait message is erased from the screen.
- ^ The cursor is displayed in the upper-left corner of the screen.
- ^ The OFF LINE and DSR indicators are turned on.

NOTE: The other keyboard indicators may or may not be on depending on the communication signals received on the modem interface connector and the feature selections of the terminal.

Any error found by the EIA loopback self-test displays an error character on the screen. Call your local DIGITAL Field Service Office whenever self-test errors are found.

5. If the terminal successfully completes the test, turn the power switch off and remove the loopback connector. If switches S1, S2, S4, S6, S8 and S9 were changed in step 2 of this procedure, change the switches to their original positions. A detailed procedure to select the communication switches is provided in Chapter 8.
6. Connect the communication cable to the terminal.

Printer Loopback Self-Test

The printer loopback self-test is used to verify that the VT131 terminal printer interface can transmit and receive characters. In the printer loopback test the transmit and receive lines are connected to each other with an external loopback connector. The terminal transmits characters on the transmit line and receives the characters on the receive line. Perform the loopback self-test using the following procedure.

1. With the power switch off, disconnect the printer cable and install the loopback connector on the printer interface connector (Figure 10-3). The loopback connector part number is 12-15336 and is available from DIGITAL Accessories and Supplies Group, refer to Chapter 11.
2. Power up the terminal. The terminal performs the power up self-test.
3. When power is on type one of the following sequences to perform the test. The terminal is off-line with the ANSI/VT52 SET-UP feature selected to ANSI (SET-UP B switch 2-3 = 1).

ESC [2 ; 16 y Performs the printer loopback self-test once.

ESC [2 ; 24 y Performs the printer loopback self-test continuously.

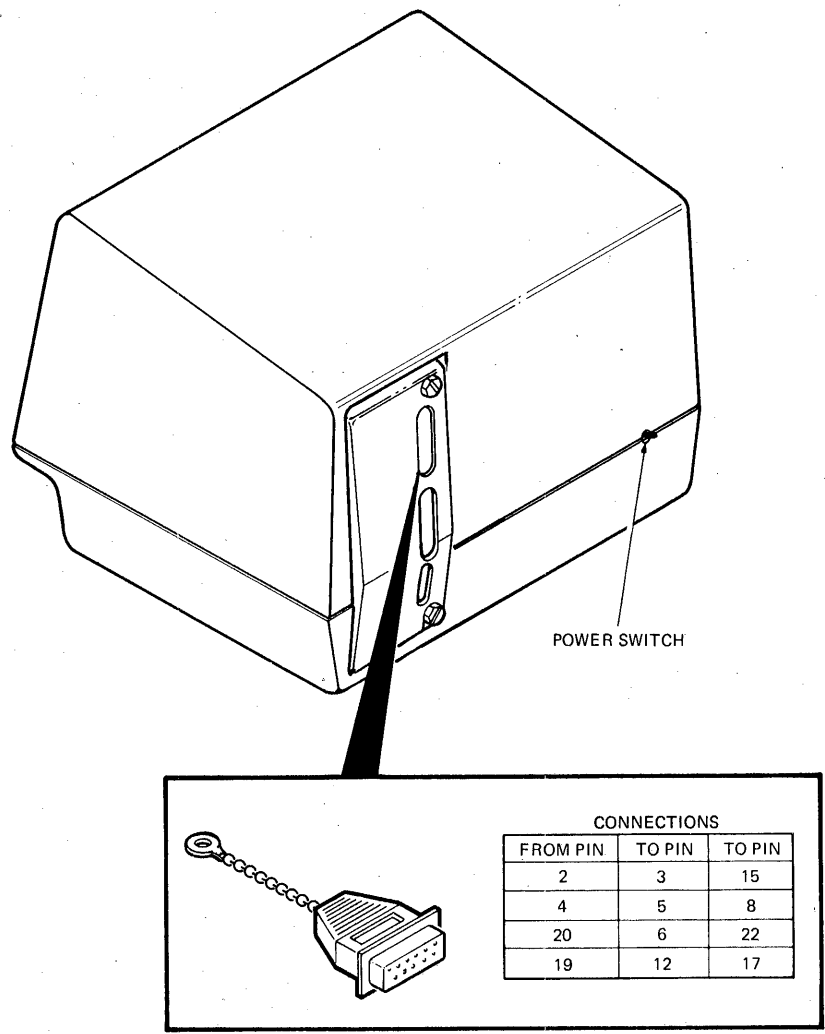

MA-7868C

Figure 10-3 EIA Loopback Connector

NOTE: The Wait message is displayed on the screen while the test is being performed. The continuously running test ends only if an error is found or if power is turned off.

The test ends with the following indications:

- ^ The Wait message is erased from the screen.
- ^ The cursor is displayed in the upper-left corner of the screen.
- ^ The OFF LINE and KBD LOCKED indicators are turned on. The KBD LOCKED indicator is turned off when the test is completed.

NOTE: The other keyboard indicators may or may not be on depending on the communication signals received on the modem interface connector and the feature selections of the terminal.

Any error found by the loopback self-test displays an error character on the screen. Any character displayed on the screen indicates a failure in the printer interface. Call your local DIGITAL Field Service Office whenever self-test errors are found.

5. Turn the power switch off, remove the loopback connector and connect the printer cable.

Printer Test

The printer test is used to verify that the printer and VT131 terminal can communicate. This test generates sample data for printing and transmits this data to the printer. If the VT131 terminal and printer can not communicate, printing cannot be performed. Perform the printer test using the following procedure.

1. Connect the printer cable to both the printer and printer interface of the terminal. Turn both the terminal and printer power switches on.
2. Ensure that the following features of the terminal match the printer.
 - ^ transmit/receive speed (baud rate)
 - ^ data/parity bits (data bits per character and parity)
3. Type the following sequence on the VT131 keyboard. The terminal is off-line with the ANSI/VT52 SET-UP feature selected to ANSI (SET-UP B switch 2-3 = 1).

ESC # 8

The screen is filled with Es.

4. Hold down the SHIFT key and press the (PRINT) key, the Es should be printed. If the Es are not printed, call your local DIGITAL Field Service Office.

CHAPTER 11
ACCESSORIES AND SUPPLIES

GENERAL

This chapter describes the accessories and supplies offered by DIGITAL for the VT131. Part numbers and ordering information are included.

ACCESSORIES

Qty	Part No	Description
1	VT1XX-AE	Formed plastic screen filter, gray, antiglare coating
1	VT1XX-AW	Formed plastic screen filter, green (AW), antiglare coating
1	VT1XX-AX	Formed plastic screen filter, yellow (AX), antiglare coating
1	VT1XX-AR	Formed plastic screen filter, amber (AY), antiglare coating
1	VT1XX-AR	Nonreflective filter screen
2	VT1XX-ST	Terminal stand with casters
2	VT1XX-SU	Terminal stand with casters (lots of 25)
2	VT1XX-SV	Terminal stand with casters (lots of 50)
3	H9850-HK	Heavy gauge vinyl dust cover, charcoal brown (2 cover set)
5	LA12X-UA	Blank keycap kit of 50, Row 4*
5	LA12X-UB	Blank keycap kit of 50, Row 1*
5	LA12X-UC	Blank keycap kit of 50, Row 2*
5	LA12X-UD	Blank keycap kit of 50, F&J type
5	LA12X-UE	Blank keycap kit of 50, SET-UP
5	LA12X-UF	Blank keycap kit of 50, TAB

*Row 1 is immediately above the space bar.

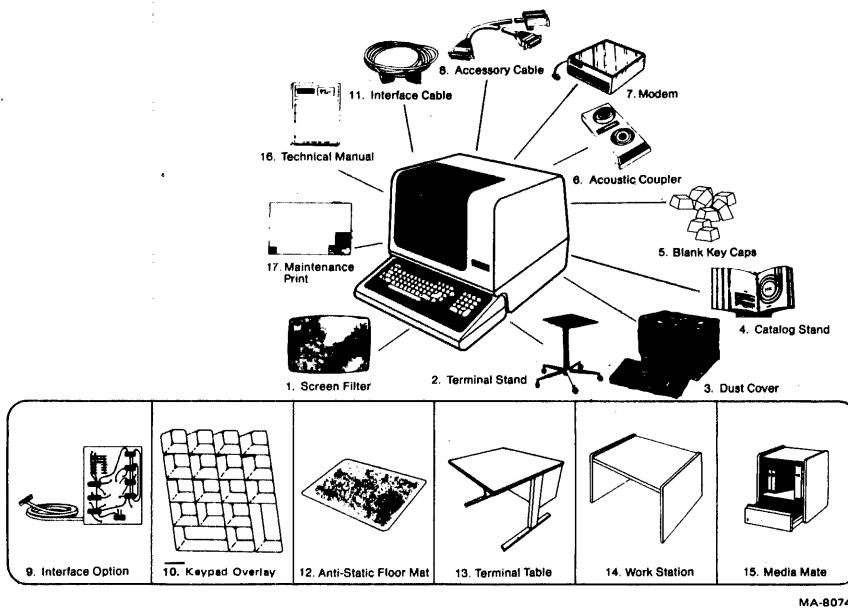

Figure 11-1 Accessories and Supplies

5	LA12X-UH	Blank keycap kit of 50, CAPS LOCK
5	LA12X-UJ	Blank keycap kit of 50, SHIFT
5	LA12X-UL	Main array blank keycap set
5	LA12X-UM	Blank keycap kit of 50, CR
5	LA12X-UN	Blank keycap kit of 50, ENTER
5	LA12X-UP	Blank keycap kit of 50, Num Pad 0
5	LA12X-UR	Blank keycap kit of 50, Row 3*
5	LA12X-US	Blank keycap kit of 50, Row 5*
5	LA12X-UT	Numeric pad blank keycap set
6	DF01-A	Acoustic telephone coupler, 300 baud
7	DF02-AA	Direct connect, Bell 103J equivalent, 300 pbs full duplex modem with EIA RS-232-C interface
8	30-10958-02	Cable interface DF01-A couplers to terminals
9	VT1XX-CA	20 mA current loop interface option with BC05F-15 cable
10	VT1XX-KA	KED/EDT keypad overlay
10	VT1XX-KB	FMS-FED (form editor) keypad overlay
10	VT1XX-KC	FMS-FDV (form driver) keypad overlay
11	BC22A-10	EIA RS-232 female-female null modem cable shielded 3.0 m (10 ft)
11	BC22A-25	EIA RS-232 female-female null modem cable shielded 7.6 m (25 ft)
11	BC22B-10	EIA RS-232 male-female extension cable shielded 3.0 m (10 ft)
11	BC22B-25	EIA RS-232 male-female extension cable shielded 7.6 m (25 ft)
11	BC23A-10	Kit of 5 BC22A-10
11	BC23A-25	Kit of 5 BC22A-25
11	BC23B-10	Kit of 5 BC22B-10
11	BC23B-25	KIT OF 5 BC22B-25

*Row 1 is immediately above the space bar.

NOTE: EIA RS-232-C specifies a maximum cable length of 15 m (50 ft). EIA RS-423 specifies a maximum cable length of 61 m (200 ft).

11	BC03M-AO	Female-female null modem cable 30.5 m (100 ft)
11	BC03M-B5	Female-female null modem cable 76.2 m (200 ft)
11	BC03M-EO	Female-female null modem cable 152.4 m (500 ft)
11	BC03M-LO	Female-female null modem cable 304.8 m (1000 ft)
11	BC05X-15	20 mA current loop extension cable 4.6 m (15 ft)
11	BC05X-25	20 mA current loop extension cable 7.6 m (25 ft)
11	BC05X-50	20 mA current loop extension cable 15.2 m (50 ft)
12	H9850-DA	Antistatic floor mat, DECmat, 122 cm X 183 cm (4 ft X 6 ft), driftwood color (brownish gray)
12	H9850-DB	Antistatic floor mat, DECmat, 122 cm X 183 cm (4 ft X 6 ft), summer earth color (brown/gold)
12	H9850-DC	Antistatic floor mat, DECmat, 91 cm X 305 cm (3 ft X 10 ft), silver birch color (silvergray/brown)
12	H9850-DD	Antistatic floor mat, DECmat, 91 cm X 305 cm (3 ft X 10 ft), autumn bronze color (orange/brown)
12	H9850-DE	Antistatic floor mat, DECmat, 91 cm X 305 cm (3 ft X 10 ft), driftwood color (brownish gray)
12	H9850-DF	Antistatic floor mat, DECmat, 122 cm X 183 cm (4 ft X 6 ft), silver birch color (silvergray/brown)
12	H9850-DH	Antistatic floor mat, DECmat, 122 cm X 183 cm (4 ft X 6 ft), autumn bronze color (orange/brown)
13	H970-EB	Terminal table, 68.6 cm high X 91.4 cm wide X 76.2 cm deep (27 in X 36 in X 30 in), with levelers

- 13 H970-HB Terminal table, 68.6 cm high X 61.0 cm wide X 76.2 cm deep (27 in X 24 in X 30 in), with levelers
- 14 H9532-AA Workstation with blue front panel and gray side panels, levelers, 122 cm wide X 76.2 cm high X 76.2 cm deep (48 in X 30 in X 30 in)
- 14 H9532-AB Workstation with brown front panel and brown side panels, levelers, 122 cm wide X 76.2 cm high X 76.2 cm deep (48 in X 30 in X 30 in)
- 15 H9850-AP Media mate, file or shelf storage cart with casters and locking drawer, 64.1 cm high X 38.1 cm deep X 47.0 cm wide (25.25 in X 15 in X 18.5 in)

RELATED DIGITAL DOCUMENTATION

Qty	Part No	Description
16	EK-VT131-UG	VT131 User Guide. Describes the installation, operation, and programming of the VT131. This document is shipped with the terminal.
16	EK-VT101-PS	VT101 Series Pocket Service Guide. Describes procedures used to troubleshoot and repair the VT131 to the field replaceable unit.
16	EK-VT101-TM	VT101 Series Technical Manual. Describes VT131 to a detailed block level. Provides troubleshooting information for the terminal. This manual does not contain detailed schematic drawings. The VT101 Family Field Maintenance Print Set has detailed schematic drawings. It is ordered separately.
16	EK-VT131-IP	VT131 Video Terminal IPB. Provides a detailed parts breakdown of the VT131 field replaceable units. This document does not contain part numbers for components on the printed circuit boards. However, components are listed in the the VT101 Family Field Maintenance Print Set. It is ordered separately.
16	EK-VT131-RC	VT131 Terminal Programming Reference Card. Provides a summary of the VT101 escape and control sequences on a pocket size reference card.
17	MP-01066	VT101 Family Field Maintenance Print Set. Provides a complete set of electrical and mechanical schematic diagrams for the VT131 terminal.

POWER CORDS

Part No	Description
17-00083-09	United States (115 V)
17-00083-10	United States (220 V)
BN03A-2E	United Kingdom
BN02A-2E	Continental Europe (SCHUKO)
BN04A-2E	Switzerland
BN05A-2E	Australia

ALIGNMENT TEMPLATES

Part No	Description
94-03220-3	Screen alignment template
94-03246-3A	Character width template
94-03246-3B	Character height template

DATA LOOPBACK TEST CONNECTORS

Part No	Description
12-15336-00	EIA loopback connector
70-15503-00	Current loop connector

SPARES KIT

4A-VT131-00	VT131 spares kit
-------------	------------------

ORDERING INFORMATION

Continental USA

Call 800-258-1720 or mail order to:

Digital Equipment Corporation
P.O. Box CS2008
Nashua, NH 03061

New Hampshire

Call 602-884-6660 or mail order to:

Digital Equipment Corporation
P.O. Box CS2008
Nashua, NH 03061

Alaska or Hawaii

Call 408-734-4915 or mail order to:

Digital Equipment Corporation
632 Caribbean Drive
Sunnyvale, CA 94086

Canada

Call 800-267-6146 or mail order to:

Digital Equipment Corporation
P.O. Box 13000
Kanata, Ontario Canada K2K 2A6
Att: A&SG Business Manager
Telex: 610-562-8732

APPENDIX A
VT131 SPECIFICATIONS

GENERAL

This appendix lists the specifications of the VT131 terminal. Also, included are X-ray emission statements, loopback connector wiring and related documentation not provided by DIGITAL.

VT131 SPECIFICATIONS

Dimensions

Monitor

Height: 36.83 cm (14.5 inch)
Width: 45.72 cm (18 inch)
Depth: 36.20 cm (14.25 inch)

Keyboard

Height: 8.89 cm (3.5 inch)
Width: 45.72 cm (18 inch)
Depth: 20.32 cm (8 inch)
Minimum table depth: 51.4 cm (20.25 inch)

Weight

Monitor

13.6 kg (30 lbs)

Keyboard

2.0 kg (4.5 lbs)

Shipping Weight

18.6 kg (41 lbs)

Environment

Operating

Temperature: 10° to 40° C
(50° to 104° F)
Relative Humidity: 10% to 90%
Maximum wet bulb: 28° C (82° F)
Minimum dew point: 2° C (36° F)
Altitude: 2.4 Km (8,000 ft)

Not Operating

Temperature: -40° to 66° C
(-40° to 151° F)
Relative Humidity: 0 to 95%
Altitude: 9.1 km (30,000 ft)

Power

Line Voltage

99--128 V RMS single phase, 2 wire
198--256 V RMS single phase, 2 wire
(selected by switch)

Line Frequency	47--63 Hz
Current	0.70 A RMS maximum at 120 V RMS 0.40 A RMS maximum at 240 V RMS
Input Power	70 watts RMS or 85 VA apparent
Current Limiting	1.25 A fast blow fuse (120 volt) 0.75 A slow blow fuse (240 volt)
Power Cord	Detachable, 3 conductor grounded.
Power Cord Receptical	EIA specified CEE22-6A
Display	
CRT	12 inch diagonal measure, P4 phosphor
Format	24 lines X 80 characters or 24 lines X 132 characters (selected from keyboard or computer)
Character	7 X 10 dot matrix with descenders
Character Size	3.35 mm X 2.0 (0.132 inch X 0.078 inch) in 80 column mode 3.35 mm X 1.3 mm (0.132 inch X 0.051 inch) in 132 column mode
Active Display Size	202 mm X 115 mm (8 inch X 4.5 inch)
Character Set	ASCII and U.K. displays 94 characters (with upper and lowercase, numeric and punctuation), 32 character special graphics set
Cursor Type	Blinking block character or blinking underline (selected from Keyboard)
Keyboard	
General	83-key detachable unit with a 1.9 m (6 ft) coiled cord attached
Key Layout	65-key arrangement and sculpturing similar to standard typewriter keyboard with an 18-key auxiliary keypad.
Auxiliary Keyboard	18-key numeric pad with period, comma, minus, enter, and four general purpose function keys.
Visual Indicators	Seven Indicators: ON LINE, OFF LINE, KBD LOCKED, CTS, DSR, INSERT and EDIT.

Audible Signals

Keyclick: audible feedback for each keystroke (selected from keyboard).

Bell:

- 1) sounds when BEL character received;
- 2) sounds eight characters from right margin (selected from keyboard).
- 3) typing error in edit mode

Multiple bell: sounds on error in SET-UP Save or Recall operation.

Modem Communication Type

Full duplex with/without modem control, asymmetric full duplex, half duplex supervisory and half duplex with coded control.

Speeds

50, 75, 110 (two stop bits), 134.5, 150, 200, 300, 600, 1200, 1800, 2000, 2400, 3600, 4800, 9600, 19,200 (selected from keyboard)

Code

ASCII (ISO 646 & CCITT Alphabet 5)

Character Format

Asynchronous

Character Size

7 or 8 bits (selected from keyboard).

Parity

Even, odd, mark, space or none (selected from keyboard)

Buffer Overflow Prevention

Automatic generation of XON and XOFF control codes (selected from keyboard)

Echo

Local echo available (selected from keyboard)

Printer Communication Type

Full duplex

Speeds

50, 75, 110 (two stop bits), 134.5, 150, 200, 300, 600, 1200, 1800, 2000, 2400, 3600, 4800, 9600, 19,200 (selected from keyboard)

Code

ASCII (ISO 646 & CCITT Alphabet 5)

Character Format

Asynchronous

Character Size

7 or 8 bits (selected from keyboard).

Parity

Even, odd, mark, space or none (selected from keyboard)

Buffer Overflow
Prevention

Automatic generation of XON and XOFF
control codes

Composite Video Output (J9)

The composite video output provides RS170 output with the following nominal characteristics, refer to Figure A-1.

1. Output impedance = 75 ohms, dc-coupled
2. Sync level = 0V
3. Black level = approximately 0.3 V when loaded with 75 ohms
4. White level = approximately 1.0 V with a 75 ohm load
5. The composite sync waveform meets EIA RS170 standards.

The vertical interval is six equalizing pulses, six vertical sync pulses, and six more equalizing pulses. The timing is as follows:

Equalizing pulse width = 2.33 us \pm 50ns
Vertical pulse width = 27.28 us \pm 200ns
Horizontal pulse width = 4.71 us \pm 50ns
Horizontal blank width = 11.84 us \pm 50ns/80 column mode
= 12.34 us \pm 50ns/132 column mode
Front Porch = 1.54 us \pm 50ns

FCC Data

This equipment generates and uses radio frequency energy. It has been type tested and found to comply with the limits for a Class B computing device in accordance with the specifications in Subset J of Part 15 of FCC rules, which are designed to provide reasonable protection against radio and television interference in a residential installation. However, there is no guarantee that interference will not occur in a particular installation. If this equipment does cause interference to radio or television reception, the user is encouraged to try to correct the interference.

X-RAY EMISSION DATA

Rated anode voltage: 12 kV (fixed)
Dose rate: less than 1.43 pA/kg (20 uR/h)*
Compliance with: . para. 5, clause (2) of German X-Ray ordinance (1973)
. CSA 22.2 #154-1975
para. 4.1.4
. CSA #65 . VDE 0804/5.72, para. 23
. UL 478 . VDE 0730 part 2P/6.76, para. 33
. ECMA 57 . VDE 0860 part 1/11.76, para. 6
. IEC 65 public. 1/1972, para. 6

Workstation exposure: does not expose the operator to dangerous X-ray radiation

* measured at a distance of 5 cm at any accessible point from the outer surface.

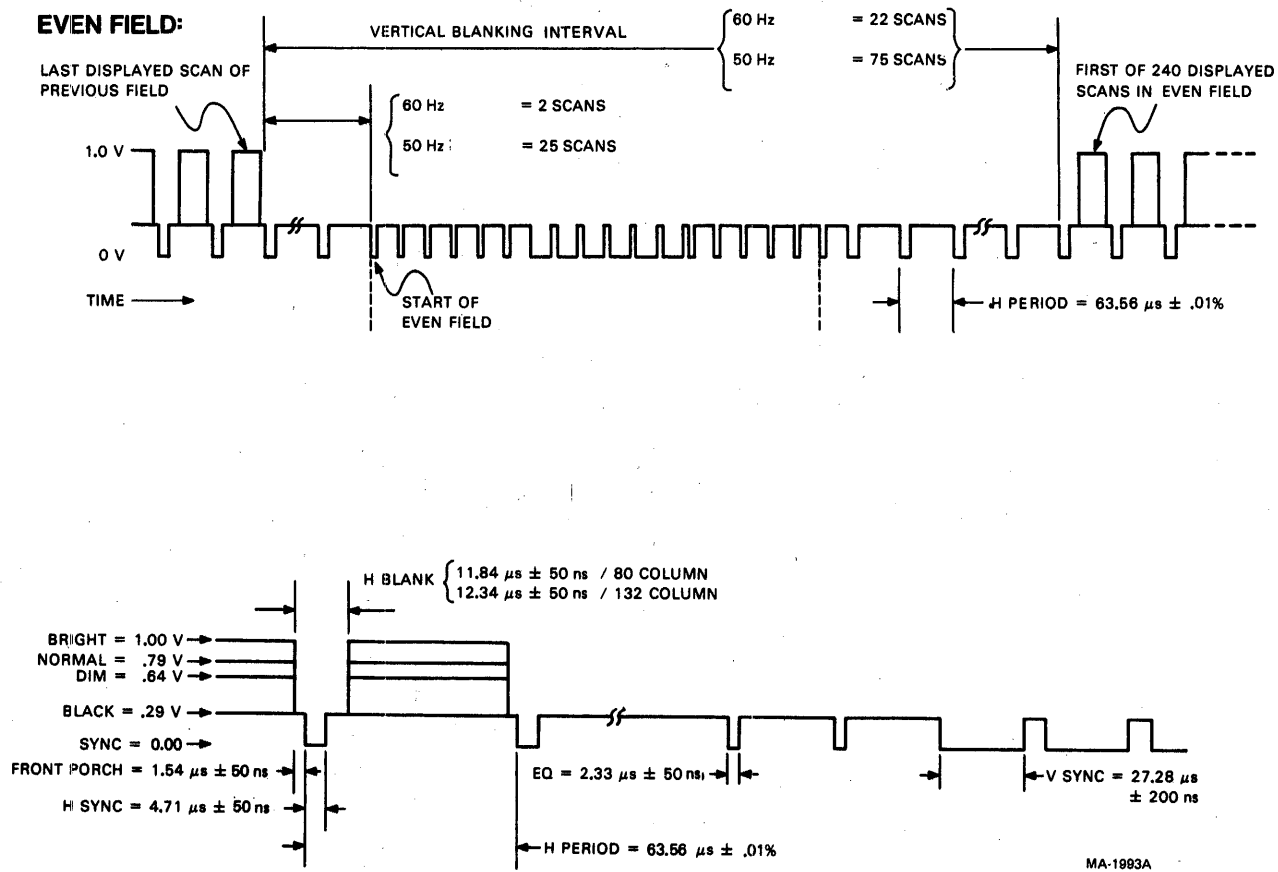

Figure A-1 Composite Video Output

LOOPBACK CONNECTOR WIRING

From	To
EIA: Pin 2	Pins 3 and 15
Pin 4	Pins 5 and 8
Pin 20	Pins 6 and 22
Pin 19	Pins 12 and 17
20 MA: Pin 1	Pin 3
Pin 2	Pin 7
Pin 5	Pin 8

RELATED DOCUMENTATION

ANSI specifications are available from:

Sales Department
American National Standards Institute
1430 Broadway
New York, NY 10018

EIA specifications are available from:

Electronic Industries Association
Engineering Department
2001 Eye St. NW
Washington, DC 20006

International standards are available from:

CCITT
U.N. Book Store
United Nations Building
N.Y., N.Y. 10017

APPENDIX B
SET-UP SUMMARY

GENERAL

This appendix provides a summary of the SET-UP features of the VT131 terminal.

SUMMARY

Figure B-1 shows the screen displays. Figure B-2 is a summary of the SET-UP features.

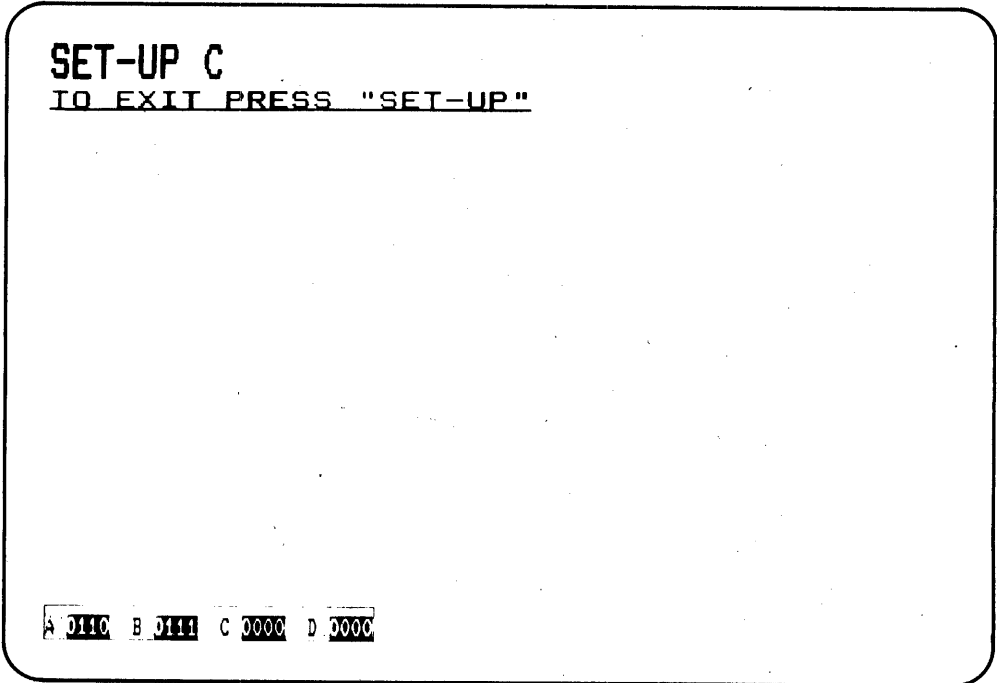

MA-3574

Figure B-1 SET-UP Displays (Sheet 2 of 2)

SET-UP B

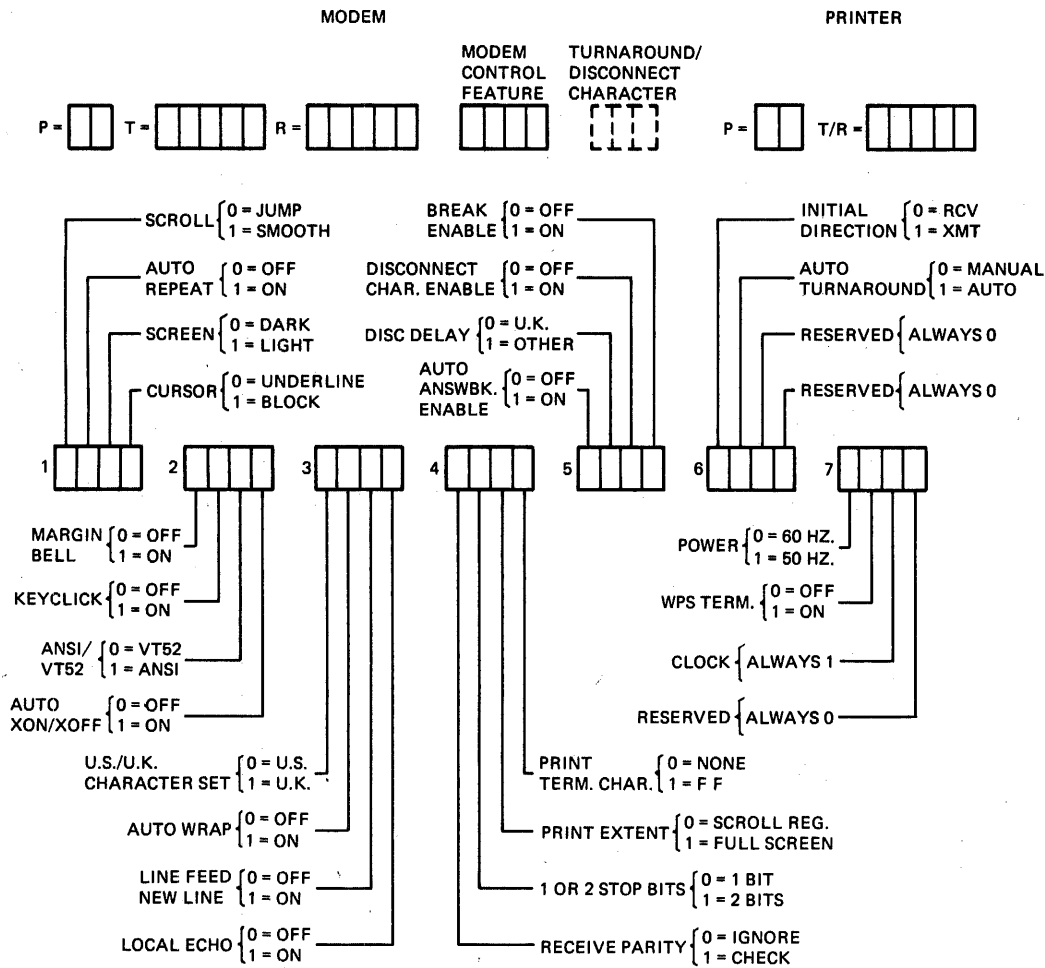

MA-9360

Figure B-2 SET-UP Display Summary (Sheet 1 of 2)

SET-UP C

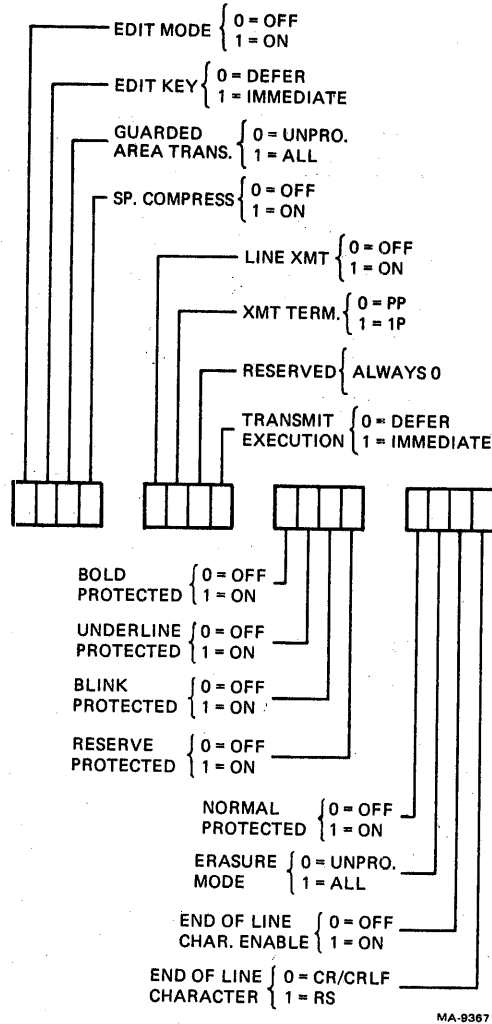

MA-9367

Figure B-2 SET-UP Display Summary (Sheet 2 of 2)

APPENDIX C
TRANSMITTED CHARACTER SUMMARY

GENERAL

This appendix lists the character codes generated by the VT131 terminal.

STANDARD KEYS

Figure C-1 shows the codes generated by the standard keys.

FUNCTION KEYS

Table C-1 lists the cursor key codes. Figure C-2 shows the control codes generated by the function keys. The shaded keys do not need the CTRL key down to generate the control character. Table C-2 lists the control codes generated.

AUXILIARY KEYPAD KEYS

Table C-3 lists the codes generated by these keys.

Table C-1 Cursor Control Key Codes

Cursor Key (arrow)	ANSI MODE		VT52 MODE
	Cursor Key Mode Reset	Cursor Key Mode Set	
Up	ESC [A Ø33 133 1Ø1	ESC O A Ø33 117 1Ø1	ESC A Ø33 1Ø1
Down	ESC [B Ø33 133 1Ø2	ESC O B Ø33 117 1Ø2	ESC B Ø33 1Ø2
Right	ESC [C Ø33 133 1Ø3	ESC O C Ø33 117 1Ø3	ESC C Ø33 1Ø3
Left	ESC [D Ø33 133 1Ø4	ESC O D Ø33 117 1Ø4	ESC D Ø33 1Ø4

Table C-2 Control Codes Generated

Control Character	Character Mnemonic	Transmitted Code (Octal)	Key Pressed with CTRL Key Down	Dedicated Key
Null	NUL	000	Space Bar	
Start of Heading	SOH	001	A	
Start of Text	STX	002	B	
End of Text	ETX	003	C	
End of Transmission	EOT	004	D	
Enquire	ENQ	005	E	
Acknowledge	ACK	006	F	
Bell	BEL	007	G	
Back Space	BS	010	H	BACK SPACE
Horizontal Tabulation	HT	011	I	TAB
Line Feed	LF	012	J	LINE FEED
Vertical Tabulation	VT	013	K	
Form Feed	FF	014	L	
Carriage Return	CR	015	M	RETURN (ENTER) *
Shift Out	SO	016	N	
Shift In	SI	017	O	
Data Link Escape	DLE	020	P	
Device Control 1	DC1 (XON)	021	Q	
Device Control 2	DC2	022	R	
Device Control 3	DC3 (XOFF)	023	S	
Device Control 4	DC4	024	T	
Negative Acknowledge	NAK	025	U	
Synchronous Idle	SYN	026	V	
End of Transmission Block	ETB	027	W	
Cancel Previous Word or Character	CAN	030	X	
End of Medium	EM	031	Y	
Substitute	SUB	032	Z	
Escape	ESC	033	[
File Separator	FS	034	\	
Group Separator	GS	035]	
Record Separator	RS	036	~	
Unit Separator	US	037	?	
Delete	DEL	177		DELETE

* The characters generated by the RETURN key can be changed by the Line Feed/New Line feature. When off, this feature causes the RETURN key to generate a single control character (CR). When on, this feature causes the RETURN key to generate two characters (CR, LF). Also, depending on the keypad mode selected, the RETURN and ENTER keys may generate the same control codes.

During half duplex coded control (HBX B) communication, the RETURN key also generates the turnaround character. The Auto Turnaround feature when selected for auto, causes the RETURN key to generate the turnaround character.

Table C-3 Auxiliary Keypad Codes

Key	ANSI MODE			VT52 MODE			
	Numeric Keypad Mode	Alternate Keypad Mode		Alternate Keypad Mode Off (Numeric Keypad Mode)	Alternate Keypad Mode On		
0	0 060	ESC 033	0 117	p 160	0 060	ESC ? 033 077	p 160
1	1 061	ESC 033	0 117	q 161	1 060	ESC ? 033 077	q 161
2	2 062	ESC 033	0 117	r 162	2 062	ESC ? 033 077	r 162
3	3 063	ESC 033	0 117	s 163	3 063	ESC ? 033 077	s 163
4	4 064	ESC 033	0 117	t 164	4 064	ESC ? 033 077	t 164
5	5 065	ESC 033	0 117	u 165	5 065	ESC ? 033 077	u 165
6	6 066	ESC 033	0 117	v 166	6 066	ESC ? 033 077	v 166
7	7 067	ESC 033	0 117	w 167	7 067	ESC ? 033 077	w 167
8	8 070	ESC 033	0 117	x 170	8 070	ESC ? 033 077	x 170
9	9 071	ESC 033	0 117	y 171	9 071	ESC ? 033 077	y 171
-	-(minus) 055	ESC 033	0 117	m 155	-(minus) 055	ESC ? 033 077	m 155
,	,(comma) 054	ESC 033	0 117	l 154	,(comma) 054	ESC ? 033 077	l 054
.	.(period) 056	ESC 033	0 117	n 156	.(period) 056	ESC ? 033 077	n 156
ENTER*	CR or CR LF 015 015 012	ESC 033	0 117	M 115	CR or CR LF 015 015 012	ESC ? 033 077	M 115
PF1	ESC O P 033 117 120	ESC 033	O 117	P 120	ESC P 033 120	ESC ? 033 077	P 120
PF2	ESC O Q 033 117 121	ESC 033	O 117	Q 121	ESC Q 033 121	ESC ? 033 077	Q 121

Table C-3 Auxiliary Keypad Codes (Cont)

Key	ANSI MODE						VT52 MODE			
	Numeric Keypad Mode			Alternate Keypad Mode			Alternate Keypad Mode Off (Numeric Keypad Mode)		Alternate Keypad Mode On	
PF3	ESC	O	R	ESC	O	R	ESC	R	ESC	? R
	Ø33	117	122	Ø33	117	122	Ø33	122	Ø33	Ø77 122
PF4	ESC	O	S	ESC	O	S	ESC	S	ESC	? S
	Ø33	117	123	Ø33	117	123	Ø33	123	Ø33	Ø77 123

* When Numeric Keypad mode is selected (Alternate keypad mode is off), the ENTER key character code can be changed by the Line Feed/New Line feature. When off, this feature causes the ENTER key to generate a single control character (CR, octal Ø15). When on, this feature causes the RETURN key to generate two characters (CR, octal Ø15 and LF, octal Ø12).

APPENDIX D
PROGRAMMING SUMMARY

GENERAL

This appendix provides a summary of how the VT131 terminal escape and control sequences.

THIS IS A REPRINT OF THE PROGRAMMING REFERENCE CARD!!



VT131 PROGRAMMING REFERENCE CARD

CONTROL CHARACTERS RECEIVED

Name	Character Mnemonic Code	Octal Code	Function
Null	NUL	000	This character is ignored when received (not stored in input buffer) and used as a fill character.
End Of Text	ETX	003	This character can be selected as a half-duplex turnaround character.
End Of Transmission	EOT	004	This character can be selected as a disconnect character or as a half-duplex turnaround character. When used as a turnaround character, the disconnect character is DLE-EOT.
Enquire	ENQ	005	This character transmits the answerback message.
Bell	BEL	007	This character generates a bell tone.
Backspace	BS	010	This character moves the cursor to the left one character position, unless it is at the left margin, in which case no action occurs.
Horizontal Tab	HT	011	This character moves the cursor to the next tab stop, or to the right margin if there are no more tab stops.

Name	Character Mnemonic Code	Octal Code	Function
			In edit mode, the tab character positions the cursor, and the character is not held in memory. When the character is received, the cursor moves to one of the following locations. <ul style="list-style-type: none"> • Next tab stop • Next field boundary (if erasure mode is set) • Next unprotected field (if erasure mode is reset) • First unprotected character position in the scrolling region (if the cursor is above the scrolling region) • Last character position of the screen (if the cursor is below the scrolling region)
			In edit mode, a tab received with no more tab stops or fields causes the cursor to move to the end of the screen or scrolling region.
Line Feed	LF	012	This character causes a line feed or a new line operation. (Refer to linefeed/new line mode.) It also causes printing when auto print is selected.
Vertical Tab	VT	013	This character is processed as LF.
Form Feed	FF	014	This character is processed as LF. It can also be selected as a half-duplex turnaround character.

Name	Character Mnemonic	Octal Code	Function
Carriage Return	CR	015	This character moves the cursor to left margin on the current line. It can also be selected as a half-duplex turnaround character.
Shift Out	SO	016	This character selects the G1 character set, as designated by a Select Character Set sequence.
Shift In	SI	017	This character selects the G0 character set, as designated by a Select Character Set sequence.
Device Control 1	DC1	021	This character is processed as XON. It causes the terminal to continue transmitting characters.
Device Control 3	DC3	023	This character is processed as XOFF. It causes terminal to stop transmitting all characters except XOFF and XON. It can also be selected as a half-duplex turnaround character.
Cancel	CAN	030	If this character is received during an escape or control sequence, the sequence is cancelled and the substitution character (#) is displayed.
Substitute	SUB	032	This character is processed as CAN.
Escape	ESC	033	This character is processed as a sequence introducer.
Delete	DEL	177	This character is ignored when received (not stored in input buffer).

ANSI COMPATIBLE SEQUENCES

Set Mode

Name	Mnemonic	Mode	Sequence
Guarded area transfer	GATM	All	ESC [1 h
Keyboard action	KAM	Locked	ESC [2 h
Insertion-replacement	IRM	Insert	ESC [4 h
Erasure	ERM	All	ESC [6 h
Send-receive	SRM	Off	ESC [1 2 h
Transfer termination	TTM	Full page	ESC [1 6 h
Line feed/new line	LMN	New line	ESC [2 0 h
Cursor key	DECCKM	Application	ESC [? 1 h
ANSI/VT52	DECANM	ANSI	N/A
Column	DECCOLM	132 column	ESC [? 3 h
Scrolling	DECSCLM	Smooth	ESC [? 4 h
Screen	DECSCNM	Reverse	ESC [? 5 h
Origin	DECOM	Relative	ESC [? 6 h
Auto wrap	DECAWM	On	ESC [? 7 h
Auto repeat	DECARM	On	ESC [? 8 h
Editing	DECEDM	Edit	ESC [? 1 0 h
Line transmit	DECLTM	On	ESC [? 1 1 h
Space compression/ field delimiter	DECSCFDM	On	ESC [? 1 3 h
Transmit execution	DECTEM	Immediate	ESC [? 1 4 h
Edit key execution	DECEKEM	Immediate	ESC [? 1 6 h
Print form feed	DECPFF	On	ESC [? 1 8 h
Print extent	DECPEX	Full screen	ESC [? 1 9 h

Reset Mode

Name	Mnemonic	Mode	Sequence*
Guarded area transfer	GATM	Unprotected	ESC [1
Keyboard action	KAM	Unlocked	ESC [2
Insertion-replacement	IRM	Replace	ESC [4
Erasure	ERM	Unprotected	ESC [6
Send-receive	SRM	On	ESC [1 2
Transfer termination	TTM	Scrolling region	ESC [1 6
Line feed/new line	LMN	Line feed	ESC [2 0
Cursor key	DECCKM	Cursor	ESC [? 1
ANSI/VT52	DECANM	VT52	ESC [? 2
Column	DECCOLM	80 column	ESC [? 3
Scrolling	DECSCLM	Jump	ESC [? 4
Screen	DECSCNM	Normal	ESC [? 5
Origin	DECOM	Absolute	ESC [? 6
Auto wrap	DECAWM	Off	ESC [? 7
Auto repeat	DECARM	Off	ESC [? 8
Editing	DECEDM	Interactive	ESC [? 1 0
Line transmit	DECLTM	Off	ESC [? 1 1
Space compression/ field delimiter	DECSCFDM	Off	ESC [? 1 3
Transmit execution	DECTEM	Deferred	ESC [? 1 4
Edit key execution	DECEKEM	Deferred	ESC [? 1 6
Print form feed	DECPFF	Off	ESC [? 1 8
Print extent	DECPEX	Scrolling Region	ESC [? 1 9

* The last character of each sequence is lowercase L (154_g).

Cursor Key Codes Generated

Cursor Key (Arrow)	ANSI Characters Generated	
	Reset (Cursor)	Set (Application)
Up	ESC [A	ESC O A
Down	ESC [B	ESC O B
Right	ESC [C	ESC O C
Left	ESC [D	ESC O D

Keypad Character Selection

Name	Mnemonic	Sequence
Alternate	DECKPAM	ESC =
Numeric	DECKPNM	ESC >

Keypad Codes Generated

Key	VT52 Numeric Keypad Mode	VT52 Alternate Keypad Mode	ANSI Numeric Keypad Mode	ANSI Alternate Keypad Mode
	0	0	ESC ? p	0
1	1	ESC ? q	1	ESC O q
2	2	ESC ? r	2	ESC O r
3	3	ESC ? s	3	ESC O s
4	4	ESC ? t	4	ESC O t
5	5	ESC ? u	5	ESC O u
6	6	ESC ? v	6	ESC O v
7	7	ESC ? w	7	ESC O w
8	8	ESC ? x	8	ESC O x
9	9	ESC ? y	9	ESC O y
- (minus)	- (minus)	ESC ? m	- (minus)	ESC O m
, (comma)	, (comma)	ESC ? l*	, (comma)	ESC O l*
. (period)	. (period)	ESC ? n	. (period)	ESC O n
ENTER	Same as RETURN	ESC ? M	Same as RETURN	ESC O M
PF1	ESC P	ESC P	ESC O P	ESC O P
PF2	ESC Q	ESC Q	ESC O Q	ESC O Q
PF3	ESC R	ESC R	ESC O R	ESC O R
PF4	ESC S	ESC S	ESC O S	ESC O S

* The last character of the sequence is lowercase L (154_g).

Select Character Sets (SCS)

Character Set	G0 Designator	G1 Designator
United Kingdom (UK)	ESC (A	ESC) A
United States (USASCII)	ESC (B	ESC) B
Special characters and line drawing set	ESC (O	ESC) O
Alternate character ROM	ESC (1	ESC) 1
Alternate character ROM - special characters	ESC (2	ESC) 2

Name	Mnemonic	Sequence
Single Shift 2	SS2	ESC N
Single Shift 3	SS3	ESC O

US/UK Character Set

BITS B4 B3 B2 B1 ROW	COLUMN								
	0	1	2	3	4	5	6	7	
0 0 0 0 0	NUL		SP	0	@	P	120	140	P
0 0 0 0 1		DC1 (NON)	!	1	A	Q	a	q	
0 0 0 1 0			2	B	R	r	b	r	
0 0 0 1 1		DC3 (NON)	3	C	S	s	c	s	
0 1 0 0 0			4	D	T	t	d	t	
0 1 0 0 1	ENQ		5	E	U	u	e	u	
0 1 0 1 0			6	F	V	v	f	v	
0 1 0 1 1	BEL		7	G	W	w	g	w	
1 0 0 0 0	BS	CAN	(8	H	X	h	x	
1 0 0 0 1	HT)	9	I	Y	i	y	
1 0 0 1 0	LF	SUB	*	10	J	Z	j	z	
1 0 0 1 1	VT	ESC	+	11	K	[k	[
1 1 0 0 0	FF		,	12	L	\	l	\	
1 1 0 0 1	CR		-	13	M]	m]	
1 1 0 1 0	SO		.	14	N	^	n	^	
1 1 0 1 1	SI		/	15	O	_	o	_	DEL

*NOTE: DEPENDS ON THE CHARACTER SET SELECTED. U.S. U.K.

KEY

ASCII CHARACTER	ESC	31	OCTAL
		27	DECIMAL
		1B	HEX

Special Characters and Line Drawing Set

BITS B4 B3 B2 B1 ROW	COLUMN								
	0	1	2	3	4	5	6	7	
0 0 0 0 0	NUL		SP	0	@	P	120	140	P
0 0 0 0 1		DC1 (NON)	!	1	A	Q	a	q	
0 0 0 1 0			2	B	R	r	b	r	
0 0 0 1 1		DC3 (NON)	3	C	S	s	c	s	
0 1 0 0 0			4	D	T	t	d	t	
0 1 0 0 1	ENQ		5	E	U	u	e	u	
0 1 0 1 0			6	F	V	v	f	v	
0 1 0 1 1	BEL		7	G	W	w	g	w	
1 0 0 0 0	BS	CAN	(8	H	X	h	x	
1 0 0 0 1	HT)	9	I	Y	i	y	
1 0 0 1 0	LF	SUB	*	10	J	Z	j	z	
1 0 0 1 1	VT	ESC	+	11	K	[k	[
1 1 0 0 0	FF		,	12	L	\	l	\	
1 1 0 0 1	CR		-	13	M]	m]	
1 1 0 1 0	SO		.	14	N	^	n	^	
1 1 0 1 1	SI		/	15	O	_	o	_	DEL

KEY

ASCII CHARACTER	ESC	33	OCTAL
		27	DECIMAL
		1B	HEX

Character Attributes

Name	Mnemonic	Sequence
Select Graphic Rendition (no attributes)	SGR	ESC [m
Select Graphic Rendition (no attributes)	SGR	ESC [0 m
Select Graphic Rendition (select bold attribute)	SGR	ESC [1 m
Select Graphic Rendition (select underline attribute)	SGR	ESC [4 m
Select Graphic Rendition (select blink attribute)	SCR	ESC [5 m
Select Graphic Rendition (select reverse video attribute)	SGR	ESC [7 m

Scrolling Region

Name	Mnemonic	Sequence
Set top and bottom margins	DECSTBM	ESC [Pt ; Pb r

Cursor Movement Commands

Name	Mnemonic	Sequence
Cursor up	CUU	ESC [Pn A
Cursor down	CUD	ESC [Pn B
Cursor forward (right)	CUF	ESC [Pn C
Cursor backward (left)	CUB	ESC [Pn D
Cursor position	CUP	ESC [Pt ; Pc H
Cursor position (home)	CUP	ESC [H
Horizontal and vertical position	HVP	ESC [Pt ; Pc f
Horizontal and vertical position (home)	HVP	ESC [f
Index	IND	ESC D
Reverse index	RI	ESC M
Next line	NEL	ESC E
Save cursor (and attributes)	DECSC	ESC 7
Restore cursor (and attributes)	DECRC	ESC 8

Tab Stops

Name	Mnemonic	Sequence
Horizontal tab set (at current column)	HTS	ESC H
Tabulation clear (at current column)	TBC	ESC [g
Tabulation clear (at current column)	TBC	ESC [0 g
Tabulation clear (all tabs)	TBC	ESC [3 g

Line Attributes

Name	Mnemonic	Sequence
Double-height top half	DECDHL	ESC # 3
Double-height bottom half	DECDHL	ESC # 4
Single-width single-height	DECSWL	ESC # 5
Double-width single-height	DECDWL	ESC # 6

Erasing

Name	Mnemonic	Sequence
Erase in line (cursor to end of line)	EL	ESC [K
Erase in line (cursor to end of line)	EL	ESC [0 K
Erase in line (beginning of line to cursor)	EL	ESC [1 K
Erase in line (entire line containing cursor)	EL	ESC [2 K
Erase in display (cursor to end of screen)	ED	ESC [J
Erase in display (cursor to end of screen)	ED	ESC [0 J
Erase in display (beginning of screen to cursor)	ED	ESC [1 J
Erase in display (entire screen)	ED	ESC [2 J

Computer Editing Functions

Name	Mnemonic	Sequence
Delete character	DCH	ESC [Pn P
Insert line	IL	ESC [Pn L
Delete line	DL	ESC [Pn M

Character Protection

Name	Mnemonic	Sequence*
Protected field attributes (no protection)	DECPRO	ESC [0]
Protected field attributes (bold protection)	DECPRO	ESC [1]
Protected field attributes (underline protection)	DECPRO	ESC [4]
Protected field attributes (blink protection)	DECPRO	ESC [5]
Protected field attributes (reverse video protection)	DECPRO	ESC [7]
Protected field attributes (all attributes off protection)	DECPRO	ESC [2 5 4]

* The last character of each sequence is | (175_a)

Transmission Request

Name	Mnemonic	Sequence
Set transmit state	STS	ESC S

Transmission Enable

Name	Mnemonic	Sequence
Transmit	DECMIT	ESC 5

End of Block Character

Name	Mnemonic	Sequence*
Transmit termination character (function disabled)	DECTTC	ESC [0]
Transmit termination character (Form Feed, FF)	DECTTC	ESC [1]
Transmit termination character (End of Text, ETX)	DECTTC	ESC [2]
Transmit termination character (End of Transmission, EOT)	DECTTC	ESC [3]
Transmit termination character (Carriage Return, CR)	DECTTC	ESC [4]
Transmit termination character (Device Control 3, DC3)	DECTTC	ESC [5]

* The last character of each sequence is | (174_g)

Print Commands

Name	Mnemonic	Sequence
Media copy (enter auto print)	MC	ESC [? 5 i
Media copy (exit auto print)	MC	ESC [? 4 i
Media copy (enter printer controller)	MC	ESC [5 i
Media copy (exit printer controller)	MC	ESC [4 i
Media copy (print screen)	MC	ESC [i
Media copy (print screen)	MC	ESC [0 i
Media copy (print cursor line)	MC	ESC [? 1 i

Reports

Name	Mnemonic	Sequence
Device status report (request status of VT131)	DSR	ESC [5 n
Response:		
Terminal OK	DSR	ESC [0 n
Terminal not OK	DSR	ESC [3 n
Device status report (request status of printer)	DSR	ESC [? 15 n
Response:		
Printer ready	DSR	ESC [? 10 n
Printer not ready	DSR	ESC [? 11 n
No printer	DSR	ESC [? 13 n
Device status report (report cursor position)	DSR	ESC [6 n
Cursor position report	CPR	ESC [P1 ; Pc R
Device attributes (what are you)	DA	ESC [c
Device attributes (what are you)	DA	ESC [0 c
Identify terminal (what are you)	DECID	ESC Z

NOTE: ESC Z is not recommended.

Device attributes Response: VT131	DA	ESC [? 7 c
-----------------------------------	----	-------------

Reset

Name	Mnemonic	Sequence
Reset to initial state	RIS	ESC c

Tests and Adjustments

Name	Mnemonic	Sequence
Screen alignment display (fill screen with "Es")	DECALN	ESC # 8
Invoke confidence test (power-up test)	DECTST	ESC [2 ; 1 y
Invoke confidence test (data loopback test; requires test connector)	DECTST	ESC [2 ; 2 y
Invoke confidence test (EIA modem control test; requires test connector)	DECTST	ESC [2 ; 4 y
Invoke confidence test (repeat power-up test continuously until failure or power-off)	DECTST	ESC [2 ; 9 y
Invoke confidence test (repeat data loopback test continuously until failure or power-off; requires test connector)	DECTST	ESC [2 ; 10 y
Invoke confidence test (repeat EIA test continuously until failure or power-off; requires test connector)	DECTST	ESC [2 ; 12 y
Invoke confidence test (printer port data loopback test; requires test connector)	DECTST	ESC [2 ; 16 y
Invoke confidence test (repeat printer port data loopback test continuously until failure or power-off; requires test connector)	DECTST	ESC [2 ; 24 y

VT52 COMPATIBLE MODE

Mode	Sequence
Enter ANSI mode	ESC <

Keypad Character Selection

Name	Sequence
Enter alternate keypad mode	ESC =
Exit alternate keypad mode (numeric keypad mode)	ESC >

NOTE: VT52 alternate keypad and numeric keypad mode different than ANSI.

Character Sets

Name	Sequence
Special graphics character set	ESC F*
Select US/UK character set (as determined by the US/UK character SET-UP feature)	ESC G

Cursor Position

Name	Sequence
Cursor up†	ESC A
Cursor down†	ESC B
Cursor right†	ESC C
Cursor left†	ESC D
Cursor to home	ESC H
Direct cursor address	ESC Y PI Pc‡
Reverse line feed	ESC I§

- * Same as special characters and line drawing set in ANSI mode.
- † Same when sent from the terminal.
- ‡ Line and column numbers for direct cursor address are single character codes whose values are the desired number plus (37₈). Line and column numbers start at one.
- § The last character of the sequence is an uppercase i (111₈).

Erasing

Name	Sequence
Erase to end of line	ESC K
Erase to end of screen	ESC J

Print Commands

Name	Sequence
Enter auto print mode	ESC ^
Exit auto print mode	ESC -
Enter printer controller mode	ESC W
Exit printer controller mode	ESC X
Print screen	ESC]
Print cursor line	ESC V

Reports

Name	Sequence
Identify (what are you)	ESC Z
Response: VT131	ESC / Z

1st Edition, August 1981

Copyright © 1981 by Digital Equipment Corporation.
All Rights Reserved.

Printed in U.S.A.

APPENDIX E
CONTROL FUNCTIONS (SEQUENCE FORMATS)

GENERAL

This appendix describes the ANSI code extension techniques as defined in standards X3.41-1974 and X3.64-1979. There are many special cases and details in the specifications that are not covered here.

CONTROL FUNCTIONS

The ANSI standards define types of characters that are used for specific purposes. The type of character is determined by the character's position in the ASCII chart. The characters of the chart are divided into two general categories: displayable characters (columns 2 through 7 of the ASCII chart) and control characters (columns 0 and 1 of the ASCII chart). This chart and the ANSI system can work for either a 7-bit or an 8-bit character environment. The VT131 uses only 7-bit characters.

NOTE: The ASCII 7-bit chart corresponds to International Standards Organization (ISO) standard 646 and International Telegraph and Telephone Consultive Committee (CCITT) alphabet #5.

All control characters and groups of characters (sequences) not intended for display on the screen are part of the system called control functions. Not all control functions perform an action in every ANSI device, but each device can recognize all control functions and discard any that do not apply to it. Therefore, each device performs a subset of the ANSI functions.

Because different devices use different subsets, compliance with ANSI does not mean compatibility between devices. Compliance only means that a particular function, if defined in the ANSI standard, is invoked by the same control function in all devices. If an ANSI device does not perform an action that has a control function defined in the ANSI standard, it cannot use that control function for any other purpose.

ESCAPE AND CONTROL SEQUENCES

Escape and control sequences are used to provide more controls than provided by the control characters of the ASCII 7-bit chart. These sequences are multiple character control functions which are not displayed but are used to control the displaying, processing, transmission of characters. At the end of the multiple character

control sequence or during an error condition, the terminal continues to display received characters. (The error conditions are defined in Chapter 4).

Escape Sequences

The format for an escape sequence is:

ESC	I...I	F
033	040-057	060-176
Escape Sequence	Intermediate Characters	Final Character
Introducer	(0 or more characters)	(1 character)

Escape Sequence Introducer - The escape sequence introducer is the ESC character (octal 033) as defined by ANSI X3.4-1977. After the ESC character is received, all characters received in the proper range are not displayed but stored to be used as control functions.

Intermediate Characters - If the characters received after the ESC character are in the octal range of 040-057 (column 2 of the ASCII chart), they are "intermediate characters". These characters are stored as part of the control function.

Final Characters - If the character received after the ESC character is in the octal range of 060-176 (columns 3-7 of the ASCII chart), it is a "final character". The final character indicates the end of the control function. The intermediate and final characters together define the function of the sequence. The terminal then performs the action specified by the control function and continues to display received characters. ANSI standard control functions have a final character in the octal range of 100-176 (columns 4-7 of the ASCII chart). Private sequences have a final character in the octal range of 060-077 (column 3 of the ASCII chart).

Example

Action: Designate ASCII character set as G0

Sequence:

```

ESC   (   B
033  050 102
|      |   |
|      |   |----- Final Character
|      |----- Intermediate Character
----- Escape Sequence Introducer

```

Control Sequence Format

The format of a control sequence is:

CSI Ø33 133	P.....P Ø6Ø-Ø77	I.....I Ø4Ø-Ø57	F 1ØØ-176
Control Sequence Introducer	Parameter Characters (Ø or more characters)	Intermediate Characters (Ø or more characters)	Final Character (1 character)

Control Sequence Introducer - The control sequence introducer (CSI) is the ESC (octal Ø33) and [(octal 133) characters as defined by ANSI X3.41-1977. These characters are used to gain 8-bit control functions using 7-bit characters. The VT131 terminal supports only 7-bit characters. After the CSI characters are received, all characters received in the proper range are not displayed but stored to be used as control functions.

Parameter Characters - If the characters received after the CSI character are in the octal range of Ø6Ø-Ø77 (column 3 of the ASCII chart), the characters are "parameter characters". The parameter characters modify the action or interpretation of the control function. The parameter characters are interpreted as private when the < = > ? characters (octal Ø74--Ø77) are transmitted at the beginning of the parameter string. (The : character (octal Ø72) is reserved.) This means that a control sequence can be specified by ANSI but the parameter function can have a private interpretation.

The terminal uses two types of parameter characters, numeric parameters and selective parameters. A numeric parameter is a parameter that represents a decimal number, designated by Pn. The decimal characters have a range of Ø (octal, Ø6Ø) to 9 (octal Ø71). A selective parameter is a parameter selected from a list of specified parameters, designated by Ps.

If more than one parameter is transmitted in the control sequence, the parameters are separated by a delimiter character, the ; character (octal Ø73).

Intermediate Characters - If the characters received after the CSI character are in the octal range of Ø4Ø-Ø57 (column 2 of the ASCII chart), they are "intermediate characters". These characters are stored as part of the control function.

NOTE: The VT131 terminal does not use intermediate characters in control functions.

Final Characters - If the character received after the CSI character is in the octal range of 1ØØ-176 (columns 4-7 of the ASCII chart), it is a "final character". The final character indicates the end of the control function. The intermediate and final characters together define the function of the sequence. The VT131 then performs the action specified by the control function

and continues to display received characters. ANSI standard control functions are assigned a final character in the octal range of 100-157 (columns 4-6 of the ASCII chart). Private sequences have a final character in the octal range of 160-176 (column 7 of the ASCII chart).

Example

Action: Clear all horizontal tabs

Sequence:

```
ESC  [  3  g
033 133 063 147
|      |  |  |
-----|----- Final Character
      |----- Parameter Character
----- Control Sequence Introducer
```

Examples

These examples show the use of multiple functions selected in one sequence, private parameters and private sequences:

```
ESC  [  ?  4  h      Set Smooth Scroll mode (? = ANSI private
033 133 077 064 150 parameter)
```

```
ESC  [  2  ;  1  y  Invoke Self test (y = ANSI private
033 133 062 073 061 171 sequence)
```

APPENDIX F
VT131/VT100 DIFFERENCES

GENERAL

This appendix describes the differences between the VT131 and VT100 video terminals.

DIFFERENCES

The VT131 terminal is a bounded video terminal with no expansion or upgrade capabilities. Therefore, the VT131 terminal differs from the VT100 because it does not support the following VT100 features:

- ^ No video input connector is provided.
- ^ No graphics connector is provided. (This was an internal connector of the VT100.)
- ^ The EIA connector pin 23 is not connected to pins 11 and 19 as on the VT100.
- ^ The STP options and report parameters (DECREPTARM) is not provided.
- ^ When using fill characters to prevent input buffer overflows, the number of fill characters needed by the VT131 are different than the VT100 terminal.
- ^ The interlace feature is not provided in the VT131 terminal.

GLOSSARY OF ANSI DEFINITIONS AND NOTATION

Active position -- The character position on the visual display that is to display the graphic symbol representing the next graphic character.

ANSI mode -- A VT102 mode in which it recognizes and responds only to escape sequences whose syntax and semantics are in accordance with ANSI specifications.

Character position -- That portion of a visual display which is displaying or is capable of displaying a graphic symbol.

Control -- A control character, an escape sequence, or a control sequence, that performs a control function.

Control character -- A character whose occurrence in a particular context initiates, modifies, or stops a control function.

Control function -- An action that affects the recording, processing, transmission, or interpretation of data.

Control sequence -- A sequence of characters that is used for control purposes to perform a control function, that begins with the control sequence introducer (CSI) control, and that may contain a parameter string.

Control sequence introducer (CSI) -- An escape sequence that provides supplementary controls and that is itself a prefix affecting the interpretation of a limited number of contiguous characters.

Control string -- A string of characters that is used to perform a control function and that is delimited by an opening and closing delimiter control.

Cursor -- A visual representation of the active position which is either a blinking reverse-video or blinking underline.

Cursor control -- A function that moves the active position.

Default -- A function-dependent value that is assumed when no explicit value, or a value of \emptyset , is specified.

Display -- The current active area of the screen, that is, the area inside the scrolling region, or the entire screen, depending on the origin mode.

Escape character (ESC) -- A control character that provides supplementary characters (code extension) and that is itself a prefix affecting the interpretation of a limited number of contiguous characters.

Escape sequence -- A sequence of characters that is used for

control purposes to perform a control function and whose first character is the escape (ESC) control character.

Final character -- A character whose bit combination terminates an escape or control sequence designated by F.

Graphic character -- A character, other than a control character, that has a visual representation normally handwritten, printed, or displayed.

Home -- The character position at the origin. [See origin mode (DECOM)].

Intermediate character -- A character whose bit combination precedes a final character in an escape or control sequence.

Numeric parameter -- A string of bit combinations that represents a number, designated by Pn or Ps.

Parameter -- (1) A string of one or more characters that represent a single value: (2) The value so represented.

Parameter string -- A string of characters that represent one or more parameter values.

Selective parameter -- A string of bit combinations that selects a subfunction from a specified list of subfunctions, designated by Ps. In general, a control sequence with more than one selective parameter causes the same effect as several control sequences, each with one selective parameter. For example, CSI Psa; Psb; Psc F is identical to CSI Psa F CSI Psb F CSI Psc F.

VT52 mode -- A VT102 mode in which it recognizes and responds only to escape sequences which DEC VT52 type terminals use.