

**VSV21 PERIPHERAL CONCENTRATOR
USER/INSTALLATION GUIDE**

Order Number: EK-VSV21-UM-001

First Printing, May 1987

The information in this document is subject to change without notice and should not be construed as a commitment by Digital Equipment Corporation. Digital Equipment Corporation assumes no responsibility for any errors that may appear in this document.

The software described in this document is furnished under a license and may be used or copied only in accordance with the terms of such license.

No responsibility is assumed for the use or reliability of software on equipment that is not supplied by Digital Equipment Corporation or its affiliated companies.

Copyright ©1987 by Digital Equipment Corporation

All Rights Reserved.
Printed in U.S.A.

The postpaid READER'S COMMENTS form on the last page of this document requests the user's critical evaluation to assist in preparing future documentation.

The following are trademarks of Digital Equipment Corporation:

DEFAULT	DIBOL	UNIBUS
DEC/CMS	EduSystem	VAX
DEC/MMS	IAS	VAXcluster
DECnet	MASSBUS	VMS
DECsystem-10	PDP	VT
DECSYSTEM-20	POT	
DECUS	RSTS	
DECwriter	RSX	

The logo for Digital Equipment Corporation, consisting of the word "digital" in a lowercase, sans-serif font. Each letter is contained within a separate, dark rectangular box, creating a segmented effect.

USA

This equipment generates, uses, and may emit radio frequency. The equipment has been type tested and found to comply with the limits for a Class A computing device pursuant to Subpart J of Part 15 of FCC rules, which are designed to provide reasonable protection against such radio frequency interference. Operation of this equipment in a residential area may cause interference in which case the user at his own expense will be required to take whatever measures may be required to correct the interference.

The information in this document is subject to change without notice and should not be construed as a commitment by Digital Equipment Co. Ltd. (DEC). Digital Equipment Co. Ltd. assumes no responsibility for any errors that may appear in this document.

No responsibility is assumed for the use or reliability of software on equipment that is not supplied by Digital Equipment Co. Ltd. or its affiliated companies. This document was prepared using an in-house documentation production system. All page composition and make-up was performed by T_EX, the typesetting system developed by Donald E. Knuth at Stanford University. T_EX is a trademark of the American Mathematical Society.

Contents

PREFACE	vi
<hr/>	
CHAPTER 1 INTRODUCTION	1-1
<hr/>	
1.1 GENERAL	1-1
<hr/>	
1.2 PHYSICAL DESCRIPTION	1-1
<hr/>	
1.3 INTERFACES	1-3
1.3.1 Serial Interfaces	1-3
1.3.1.1 Bulkhead Panel	1-3
1.3.1.2 Remote Interface Box	1-3
1.3.2 AC Mains Interface	1-8
1.3.3 Video Interface	1-5
<hr/>	
1.4 GENERAL SPECIFICATIONS	1-8
1.4.1 Environmental Conditions	1-5
1.4.2 Electrical Conditions	1-5
1.4.2.1 VSV21-AA Module	1-5
1.4.2.2 Remote Interface Box	1-5
1.4.3 Performance	1-8
1.4.3.1 Communications Links	1-8
1.4.3.2 Peripheral Devices	1-8
1.4.4 Cables	1-8
<hr/>	
CHAPTER 2 INSTALLATION PROCEDURE	2-1
<hr/>	
2.1 OPTION COMPONENTS	2-1
<hr/>	
2.2 INSTALLATION	2-3
2.2.1 Pre-Installation Check	2-7
2.2.2 Serial Link and Video Cables	2-7

Contents

2.2.3	Remote Interface Box	2-7
2.2.3.1	Desktop Mounting	2-7
2.2.3.2	Wall Mounting	2-8
2.2.3.3	Floor Mounting	2-8
2.2.4	Options VSV21-CB, CC, CD, DB, DC and DD	2-10
2.2.5	Options VSV21-AP and AQ	2-11
<hr/> CHAPTER 3 DIAGNOSTICS		3-1
3.1	GENERAL	3-1
3.2	MAINTENANCE STRATEGY	3-1
3.2.1	Preventative Maintenance	3-1
3.2.2	Corrective Maintenance	3-1
3.3	DIAGNOSTICS OVERVIEW	3-1
3.3.1	The Power-Up Self-Test (VSV21-AA Module)	3-2
3.3.2	Host-Based Diagnostics	3-3
<hr/> CHAPTER 4 CHECKOUT AND ACCEPTANCE		4-1
4.1	ON-BOARD DIAGNOSTIC	4-1
4.1.1	Test Indications	4-1
4.1.2	Monitor Adjustment	4-3
4.2	HOST-BASED DIAGNOSTICS	4-3
4.2.1	XXDP + Diagnostic Programs	4-3
4.3	RUNNING PDP-11 DIAGNOSTICS	4-5
4.4	RUNNING μ VAX MDM DIAGNOSTICS	4-10

Contents

APPENDIX A LK-201 KEYBOARD CODES

A-1

FIGURES

1-1	Simple Block Diagram of the VSV21 Peripheral Concentrator Option _____	1-2
1-2	Bulkhead Panel Connector Pin Allocations _____	1-4
1-3	Remote Interface Box Connector Pin Allocations - Part A _____	1-6
1-4	Remote Interface Box Connector Pin Allocations - Part B _____	1-7
2-1	INSTALLATION WARNINGS _____	2-4
2-2	INSTALLATION WARNINGS (contd) _____	2-5
2-3	INSTALLATION WARNINGS (contd) _____	2-6
2-4	Remote Interface Box Installation Details _____	2-8
2-5	Bulkhead Panel for the VSV21 Peripheral Concentrator Option _____	2-12
2-6	Bulkhead Panel Installed on System Boxes _____	2-13
2-7	Cable Layout _____	2-14
2-8	Console Connection on BA11-S Systems _____	2-15
2-9	Console Connections on BA23 Systems _____	2-16
2-10	Console Connections on BA123 Systems _____	2-17
2-11	Terminal Connection on BA11-S Systems _____	2-18
2-12	Terminal Connections on BA23 Systems _____	2-19
2-13	Terminal Connections on BA123 Systems _____	2-20
4-1	On-Board Diagnostic LED Indication _____	4-2
4-2	Self-Test Picture _____	4-4
A-1	Layout of an LK-201 Keyboard _____	A-2

TABLES

1-1	Serial Cable Wire List _____	1-9
2-1	VSV21 Peripheral Concentrator Options _____	2-1
4-1	Diagnostic Tests Under MDM _____	4-13
A-1	LK-201 Decimal Codes _____	A-3

Preface

Intended Audience

This manual:

- Provides the user of the VSV21 peripheral concentrator option with all the information necessary to operate it successfully.
- Contains the procedures for the installation, checkout and acceptance of the option following delivery of the equipment. These procedures have been developed for use by DIGITAL field engineers and by users.

The manual should be read in conjunction with the VSV21 Installation Manual and the VSV21 User Guide.

NOTES AND WARNINGS

Notes and warnings are defined as follows:

- A NOTE contains general information.
- A WARNING is designed to prevent personal injury.

Note

Before beginning the installation, you must make sure that the equipment, documentation, and software are complete, correct and undamaged. See Chapter 2 for the procedure you should follow.

Associated Documents

The related documents for the VSV21 peripheral concentrator option are listed below.

- VSV21 Installation Manual AZ-FV71B-TC
- VSV21 User Guide AZ-FV70B-TC
- VSV21 Programmer's Guide AA-FV67B-TC

Preface

- VSV21 Pocket Service Guide EK-VSV21-PS
- VR241-A Video Monitor Installation Manual EK-VR241-IN

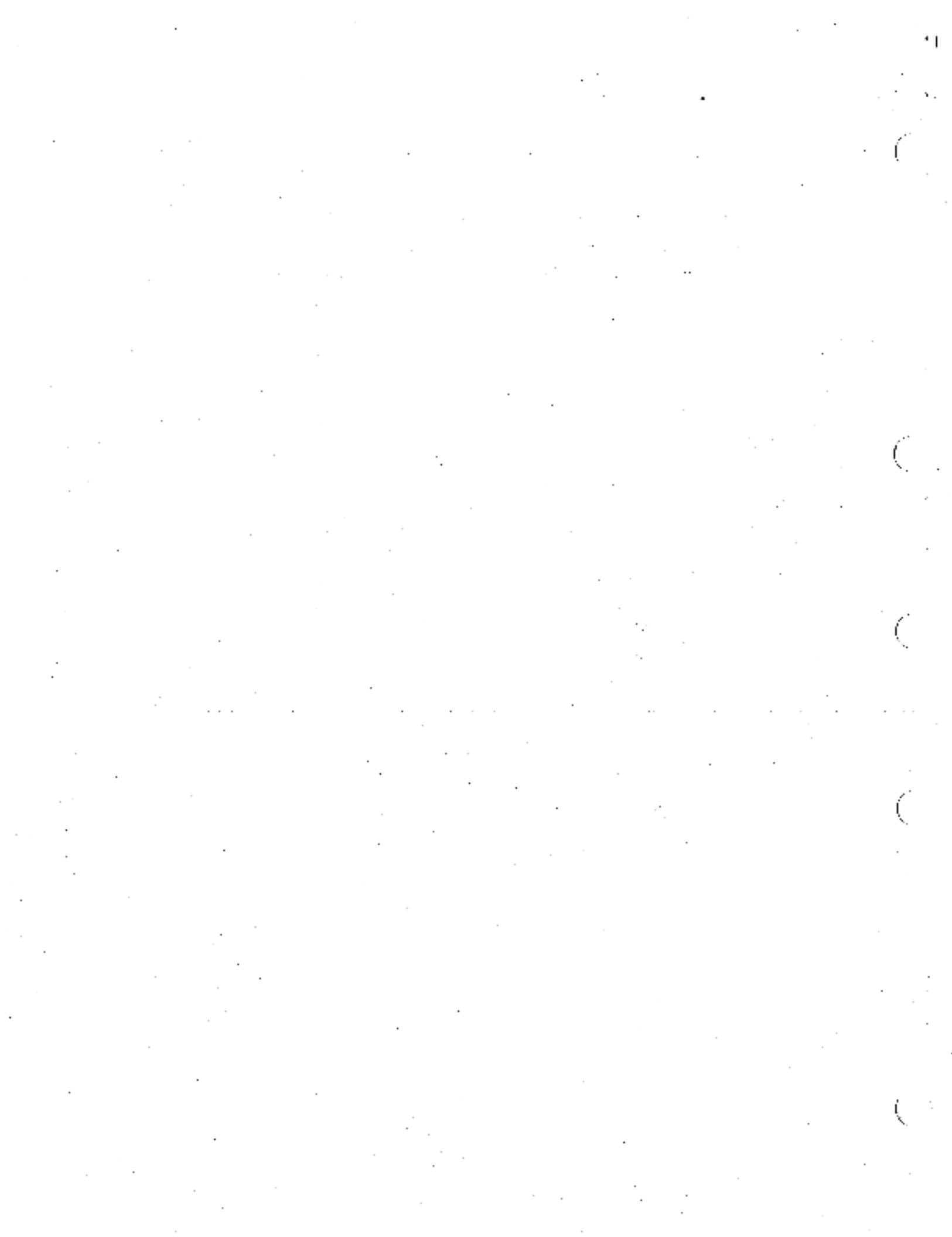

1

INTRODUCTION

1.1 GENERAL

The VSV21 peripheral concentrator option enables the VSV21 user devices (keyboard and pointing device) to be sited remote from the host processor. All the facilities normally associated with VSV21 operation are supported by the option. The simple block diagram of a VSV21 installation containing the peripheral concentrator is shown below.

1.2 PHYSICAL DESCRIPTION

The VSV21 peripheral concentrator option is available in a range of kits which provides for both new and existing VSV21 users, a variety of host processor enclosures, various distances between the host and the remote workstation, and the local ac mains supply voltage. A complete list of the option items is given in Table 2-1.

The basic option comprises:

- A remote interface box.
This box is installed at the remote workstation. It contains circuits which convert from the serial data link connector to connectors suitable for the user devices. The box also houses a power supply unit providing peripheral power.
- A bulkhead-mounting I/O panel.
The bulkhead panel houses the serial port connectors and the color video output connectors. Three specific bulkhead panel kits cater for the normal range of host cabinets encountered. These kits include the ribbon and coaxial cable assemblies used to connect the module to the bulkhead panel (see Table 2-1).
- A loopback connector enabling testing to the remote end of the serial cable.

The following additional items are not included with the option and must be ordered as required:

- A serial cable.

INTRODUCTION

Figure 1-1 Simple Block Diagram of the VSV21 Peripheral Concentrator Option

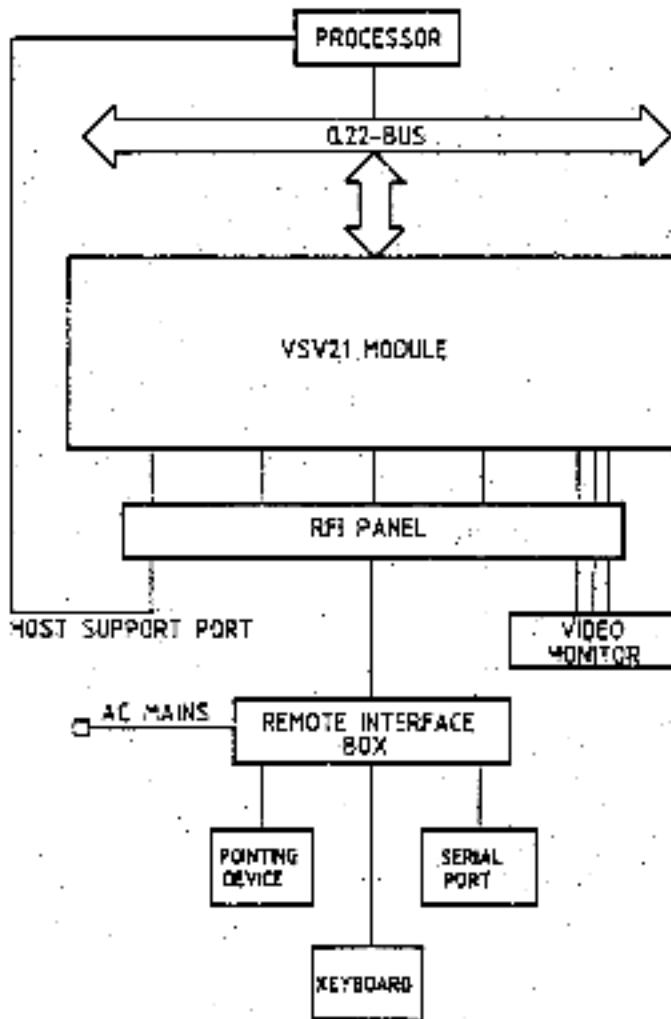

INTRODUCTION

This is a shielded cable assembly carrying the serial lines to and from the remote interface box and the bulkhead panel. The assembly is available in two discrete lengths (see Table 2-1).

- A video cable.

This is a 3-way coaxial cable assembly providing the video link between the bulkhead panel and the color monitor. The assembly is available in two discrete lengths (see Table 2-1).

1.3 INTERFACES

1.3.1 Serial Interfaces

1.3.1.1 Bulkhead Panel

Two serial I/O ports are provided on the bulkhead panel. These ports are for:

- Host processor support via the console port or a serial line (D-9 type connector).
- Serial data to and from the remote interface box (D-25 type connector).

1.3.1.2 Remote Interface Box

Five serial I/O ports are provided on the remote interface box. These ports are for:

- DATA LINK - serial data to and from the VSV21 module (D-25 type connector).
- PD1 - non-DEC serial joystick, trackball or mouse (D-25 type connector).
- PD2 - DEC data tablet or mouse (Micro-DIN connector).
- AUX - serial port (D-9 type connector).
- KSD - LK201 keyboard (keyboard jack connector).

INTRODUCTION

Figure 1-2 Bulkhead Panel Connector Pin Allocations

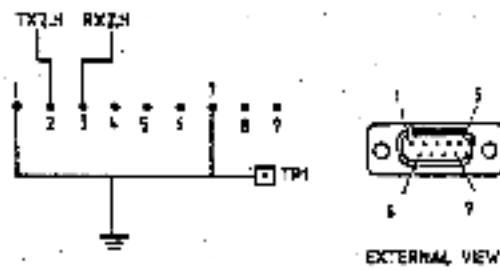

HOST - 9-WAY D TYPE

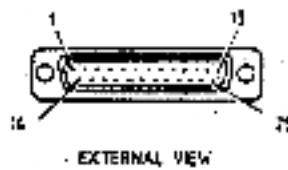
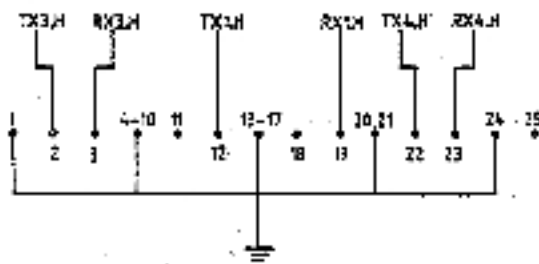

DATA LINK - 25-WAY D TYPE

INTRODUCTION

1.3.2 AC Mains Interface

The remote interface box is fitted with an IEC power socket to enable connection of the local ac mains supply.

1.3.3 Video Interface

The video output is provided at the bulkhead panel as red, green, blue (with sync on green) to RS-343 standard.

1.4 GENERAL SPECIFICATIONS

1.4.1 Environmental Conditions

- Storage temperature: -40 °C to 66 °C (-40 °F to 151 °F)
- Operating temperature: 10 °C to 40 °C (50 °F to 104 °F)
- Relative humidity: 10% to 90% non-condensing

1.4.2 Electrical Conditions

1.4.2.1 VSV21-AA Module

The electrical conditions for the VSV21 module are as detailed in the VSV21 User Guide except that no peripheral power is drawn via the VSV21 module when the peripheral concentrator option is fitted.

1.4.2.2 Remote Interface Box

The electrical conditions for the remote interface box are detailed below.

- AC mains requirements:
 - VSV21-CA : 115V (nominal), 50/60Hz, 40W (maximum).
 - VSV21-DA : 230V (nominal), 50/60Hz, 40W (maximum).
- Power can be provided to the peripherals through the serial interfaces as follows:
 - +5V dc \pm 5% at 1A (maximum), with circuit breaker protection of 4A.

INTRODUCTION

Figure 1-3 Remote Interface Box Connector Pin Allocations - Part A

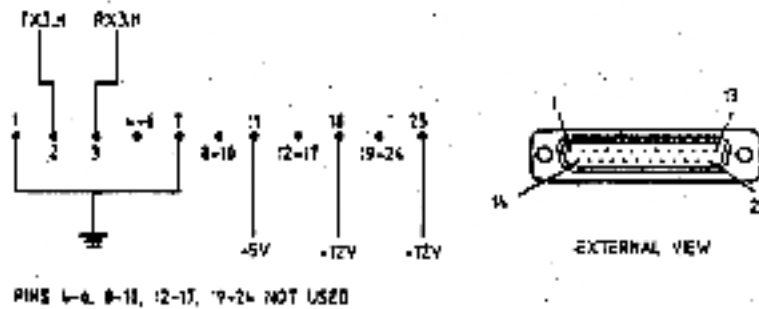

P01 - 25-WAY 'D' TYPE

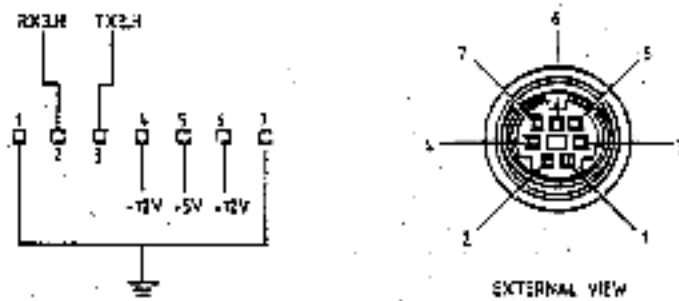

P02 - 7-WAY HIRO-DIN TYPE

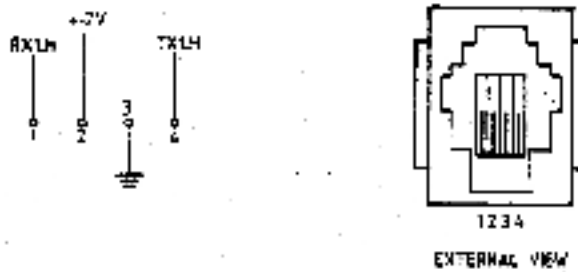

P03 - TELEPHONE JACK

INTRODUCTION

Figure 1-4 Remote Interface Box Connector Pin Allocations - Part B

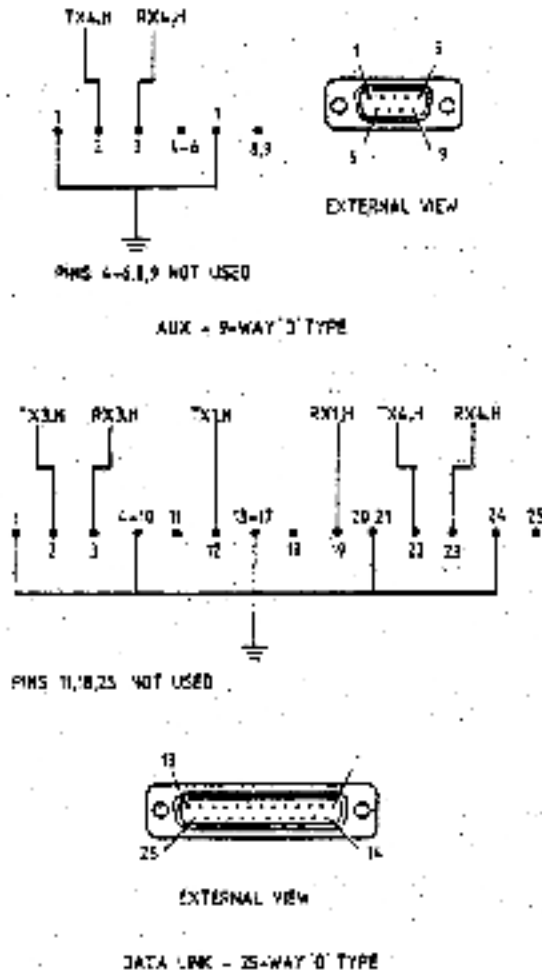

INTRODUCTION

- +12V dc $\pm 5\%$ at 1A (maximum), short circuit protected.
- -12V dc +10% -25% at 0.2A (maximum), short circuit protected.

1.4.3 Performance

1.4.3.1 Communications Links

The four serial ports support data rates of up to 9600 baud.

1.4.3.2 Peripheral Devices

- The recommended maximum cable length between the host and the remote interface box is 50 feet, and distances up to this maximum can be accommodated by using DEC-supplied cable assemblies (see Table 2-1).
- Operation at distances up to 100 feet is possible, using customer-supplied cables (see Section 1.4.4).

1.4.4 Cables

Note

The equipment is designed to conform with international safety standards (UL, CSA and IEC). It is recommended that any customer-supplied cables should also conform with these standards.

Any customer-supplied cabling between the host and the remote interface box and the monitor should meet the following specifications:

- Serial cable:
 - The capacitance between conductors of the cable shall be less than 15 pF per foot.
 - The cable shall contain 16 conductors, each of 24 AWG stranded (7 x 32).
 - The screen to connector termination shall be 360 degree termination, NOT via the drain wire.
 - The cable shall be fitted with the following connectors:
 - P1 - Male 28-way 'D' type (AMP Part No. 207464-2 or equivalent).

INTRODUCTION

- P2 - Female 25-way 'D' type (AMP Part No. 207464-1 or equivalent).
- The cable shall be wired in accordance with Table 1-1.
- Video cable:
 - The cable shall have a characteristic impedance of 75 ohms (for example, RG 59B type).
 - An industrial standard BNC male connector shall be fitted at each end of the cable.

Table 1-1 Serial Cable Wire List

From	To
P1 SHELL (VIA BRAIDING)	P2 SHELL
P1-1	P2-1
P1-2	P2-2
P1-3	P2-3
P1-4	P2-4
P1-5	P2-5
P1-6	P2-6
P1-7	P2-7
P1-8	P2-8
P1-11	P2-11
P1-12	P2-12
P1-16	P2-16
P1-19	P2-19
P1-20	P2-20
P1-22	P2-22
P1-23	P2-23
P1-25	P2-25

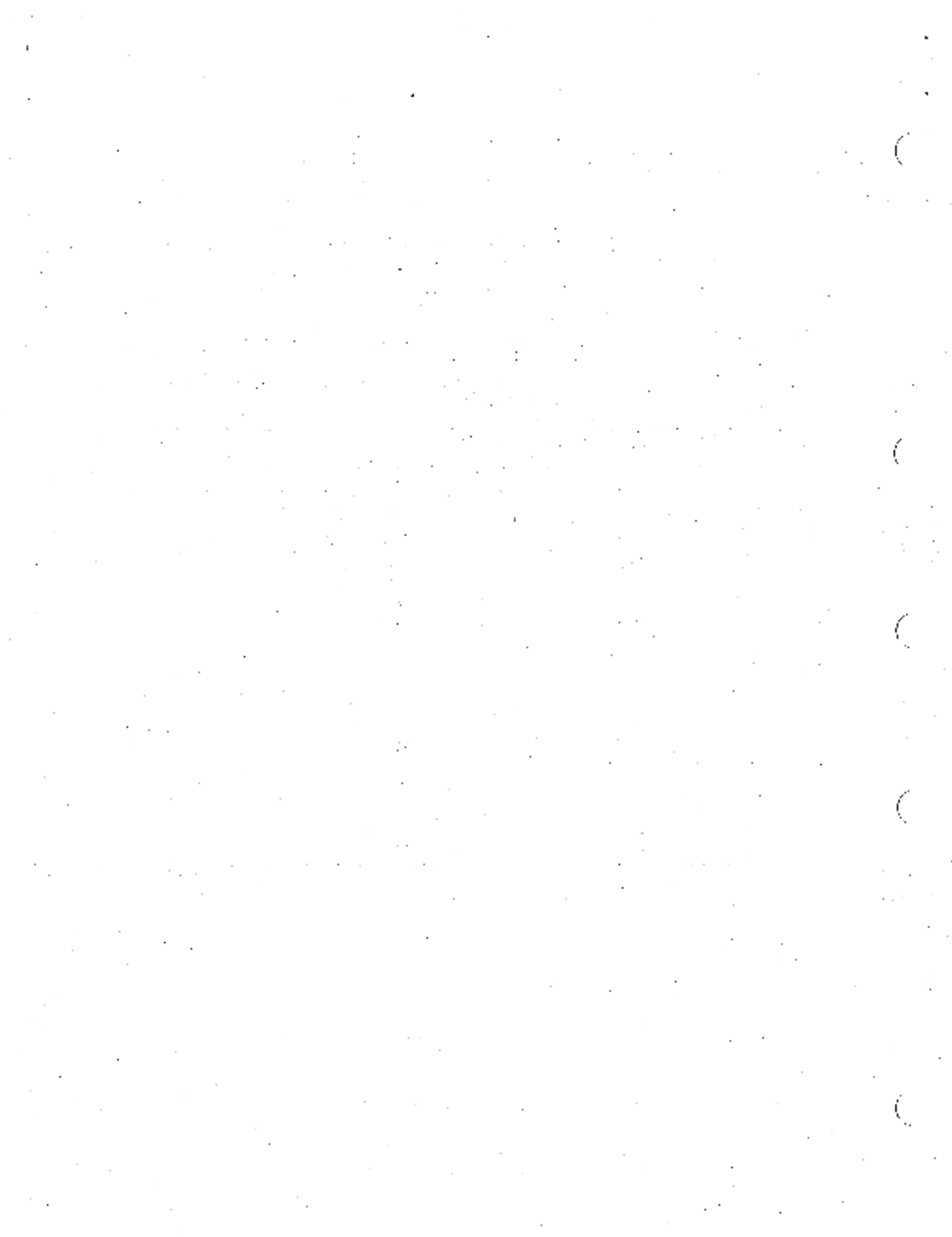

2

INSTALLATION PROCEDURE

2.1 OPTION COMPONENTS

The VSV21 Peripheral Concentrator option may consist of the following items:

- A VSV21-AA module (new users only)
- A remote interface box
- An I/O bulkhead panel and internal cabling

A full list of the options available is given in Table 2-1 below

Table 2-1 VSV21 Peripheral Concentrator Options

Option	Description
VSV21-CA	Remote Interface Box (120 volts), comprising: 1 x Box, Part No. 70-24335-01 1 x Peripheral Concentrator Loopback Test Connector Part No. 70-24332-01 1 x VSV21 Host Loopback Test Connector, Part No. 70-20130-01 1 x Fuse, Part No. 90-07212-00
VSV21-DA	Remote Interface Box (240 volts), comprising: 1 x Box, Part No. 70-24335-02 1 x Peripheral Concentrator Loopback Test Connector Part No. 70-24332-01 1 x VSV21 Host Loopback Test Connector Part No. 70-20130-01 1 x Fuse, Part No. 90-07212-00

INSTALLATION PROCEDURE

Table 2-1 (Cont.) VSV21 Peripheral Concentrator Options

Option	Description
	<p>Cabinet Kit for BA23, comprising:</p> <p>1 x Bulkhead Panel, Part No. 70-24336-01</p> <p>1 x 12-inch Data Cable, Part No. 70-20093-01</p> <p>1 x 12-inch Video Cable, Part No. 70-20094-01</p>
	<p>Cabinet Kit for BA123, comprising:</p> <p>1 x Bulkhead Panel, Part No. 70-24336-01</p> <p>1 x 30-inch Data Cable, Part No. 70-20093-02</p> <p>1 x 30-inch Video Cable, Part No. 70-20094-02</p>
	<p>Cabinet Kit for BA11-3/H9642, comprising:</p> <p>1 x Bulkhead Panel, Part No. 70-24336-01</p> <p>1 x Panel Adaptor, Part No. 74-28884-00</p> <p>1 x 36-inch Data Cable, Part No. 70-20093-03</p> <p>1 x 36-inch Video Cable, Part No. 70-20094-03</p>
VSV21-CB	VSV21-CA + VSV21-AA + Cabinet Kit for BA23
VSV21-CC	VSV21-CA + VSV21-AA + Cabinet Kit for BA123
VSV21-CD	VSV21-CA + VSV21-AA + Cabinet Kit for BA11-3/H9642
VSV21-DB	VSV21-DA + VSV21-AA + Cabinet Kit for BA23
VSV21-DC	VSV21-DA + VSV21-AA + Cabinet Kit for BA123
VSV21-DD	VSV21-DA + VSV21-AA + Cabinet Kit for BA11-3/H9642
VSV21-AP	VSV21-CA + Bulkhead Panel, Part No. 70-24336-01
VSV21-AQ	VSV21-DA + Bulkhead Panel, Part No. 70-24336-01
BC22E-25	Serial Cable, VSV21-CA, DA to Host, 25 feet
BC22E-50	Serial Cable, VSV21-CA, DA to Host, 50 feet
BC24M-25	Video Cable, Monitor to Host, 25 feet

INSTALLATION PROCEDURE

Table 2-1 (Cont.) VSV21 Peripheral Concentrator Options

Option	Description
BC28M-5D	Video Cable, Monitor to Host, 50 foot

2.2 INSTALLATION

To install the option, you must perform the following tasks, as detailed in the remaining sections of this chapter:

- Check that all the option items are available.
- Install the serial link and video cables.
- Install the remote interface box.
- Attach the peripheral concentrator I/O bulkhead panel to the enclosure of the host system.
- Options VSV21-CB, CC, CD, DB, DC and DD only:
 - Configure the M7656 module for correct addresses and graphics resolution.
 - Plug the module into the backplane of the host box.
- Install and connect the cables between the module and the bulkhead panel.
- Connect a host serial port to the VSV21 serial port, if necessary.
- Connect the serial link and video cables.
- Connect such peripherals as the keyboard and pointing device to the remote interface box.
- Check the local ac mains supply is as indicated on the remote interface box, and connect the supply to the box.
- Run appropriate diagnostic programs to verify that all installed items are operating correctly.

INSTALLATION PROCEDURE

Figure 2-1 INSTALLATION WARNINGS

WARNING

The procedures described in this chapter involve the removal of the system covers, and should be performed only by trained personnel.

ATTENTION

Les procédures décrites dans ce chapitre nécessitent l'enlèvement des capots du système. Elles ne pourront être effectuées que par du personnel qualifié.

VORSICHT!

Bei der Ausführung der in diesem Kapitel beschriebenen Anweisungen müssen die Systemabdeckungen entfernt werden. Dies sollte nur von geschultem Personal ausgeführt werden.

¡ATENCIÓN!

Los procedimientos descritos en este capítulo incluyen el desmontaje de las cubiertas del sistema y debe ser realizado solamente por personal entrenado.

ADVARSEL!

Ifølge de procedurer, som er beskrevet i dette kapitel, skal systemets beskyttelsesplader fjernes; dette bør kun udføres af personer der ved hvordan dette skal gøres.

INSTALLATION PROCEDURE

Figure 2-2 INSTALLATION WARNINGS (cont'd)

WAARSCHUWING

Bij de procedures die in dit hoofdstuk worden beschreven dienen bepaalde delen van de systeemomhulling te worden verwijderd; dit mag uitsluitend worden gedaan door opgeleid personeel.

VAROITUS!

Tässä luvussa kuvatur roimenpiteet liittyyvät järjestelmän suojakansien irrottamiseen. Ainoastaan koulutettu henkilökunta saa suorittaa nämä roimenpiteet.

ATTENZIONE

La procedura descritta in questo capitolo comporta la rimozione delle coperture e deve essere eseguita solo da personale specializzato.

ADVARSEL

I dette kapitlet beskrives bl. a. hvordan man fjerner dekslene rundt systemet. Dette arbeidet må bare utføres av fagfolk.

INSTALLATION PROCEDURE

Figure 2-3 INSTALLATION WARNINGS (contd)

AVISO

Os procedimentos descritos neste capítulo respeitam à forma como se retiram as proteções do sistema. Dada a sua especificidade, recomendamos que seja executado por pessoal especializado.

WARNING

I detta kapitel beskrivs hur systemkaapan tas bort. Detta faar endast utfoeras av utbildad personal.

注意

本章では、本体カバーの取り外し手順について述べてあります。作業は、必ず専門の担当者によっておこなってください。

אזהרה

התהליך המתואר בפרק זה, כולל הסרת הגנה על המערכת. בשל הספציפיות שלו, מומלץ לבצע את ההסרה על ידי אדם מיומן.

INSTALLATION PROCEDURE

2.2.1 Pre-Installation Check

Before proceeding with the installation, perform the following steps:

- Installation Engineer:
 - Check off from the shipping list or customer order that all items have arrived. Inform the Installation Unit Manager of any missing items.
 - Examine all items for damage. Report any damaged items to the Installation Unit Manager and DIGITAL Sales Administration.
- Customer:
 - Report any missing or damaged item to your supplier, that is DIGITAL Sales Administration or the distributor you have used.

2.2.2 Serial Link and Video Cables

The procedures required for the installation of the serial link and video cables will vary from system to system, and hence are not detailed here. However, irrespective of the precise system, the precautions regarding the use and routing of the serial link cables noted below must be observed.

Note

Signalling over the serial link cables is in RS232-C format. RS232-C is intended for local communication. In general, the communication devices can become non-operational or be damaged if the total cable length exceeds 100 metres (300 feet). The cable should not be run outdoors, and the low voltage data wiring must be separated from ac power wiring. The installation or sites may require additional devices to correct problems in communication.

2.2.3 Remote Interface Box

The remote interface box may be desktop, floor or wall mounted. Proceed as detailed in the appropriate paragraph below.

2.2.3.1 Desktop Mounting

Fit the four rubber feet supplied to the underside of the box, optionally using the fixing screws provided.

INSTALLATION PROCEDURE

2.2.3.2 Wall Mounting

Refer to Figure 2-4 and proceed as follows:

- 1 Fit the box mounting plate to the wall at the required location, observing the orientation indicated in Figure 2-4.
- 2 Remove the fixing screws from the four rubber feet (if fitted) supplied with the kit. Retain the screws. Discard the rubber feet.
- 3 Fit the screws retained in step 2 into the threaded holes in the underside of the box. Enter each screw into its hole until the clearance between the screwhead and the box is approximately equal to the thickness of the mounting plate.
- 4 Fit the remote interface box to the mounting plate (with the connectors facing downwards) by locating the four screws in the keyhole slots in the mounting plate. If necessary, remove the box and adjust the screws as required to obtain a snug fit with each screw correctly located in its slot.
- 5 Secure the box to the two side brackets of the mounting plate, using the screws and washers provided.

2.2.3.3 Floor Mounting

Two methods of floor mounting the remote interface box are available to the user:

- Free standing unit - Fit the four rubber feet as described in Section 2.2.3.1.
- Fixed unit - Secure the mounting plate to the floor and mount the box on the plate using a similar procedure to that described for wall mounting (Section 2.2.3.2).

INSTALLATION PROCEDURE

Figure 2-4 Remote Interface Box Installation Details

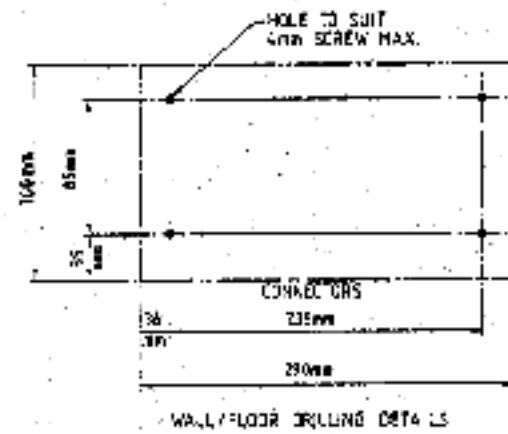
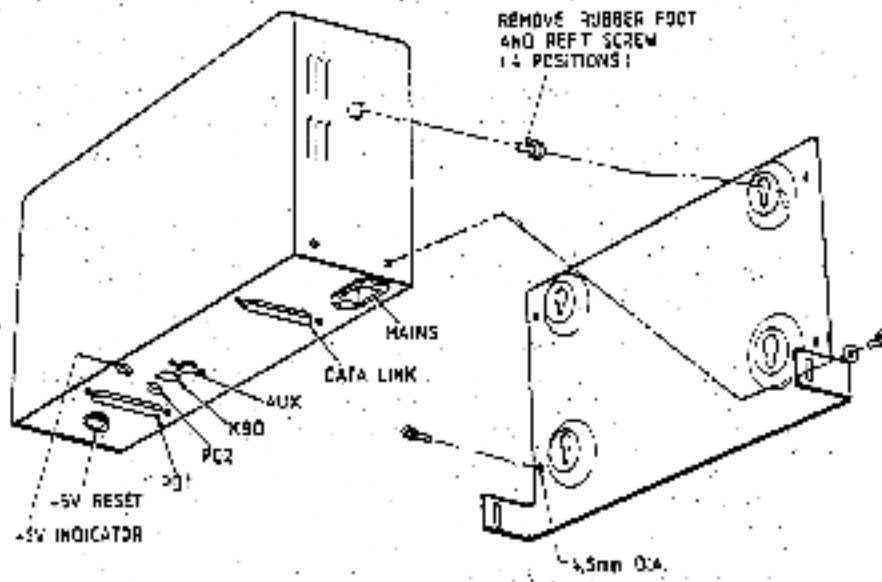

INSTALLATION PROCEDURE

2.2.4 Options VSV21-CB, CC, CD, DB, DC and DD

1. Install the serial link and video cables in accordance with Section 2.2.2
2. Install the remote interface box as detailed in Section 2.2.3
3. Find the bulkhead panel 70-24336-01, for installation into a BA23 or BA123 box. For installation into a H9642 cabinet with a BA11-S box, you must also have a 74-28684-00 adaptor plate. Figure 2-5 shows these items.
4. Find a suitable blank rear I/O panel on the BA23/BA123 system box, and remove it, taking care to save the screws. On the H9642 cabinet (with a BA11-S box), find and remove a blank I/O sub-panel on the H349 connector panel.
5. Mount the new bulkhead panel using the screws saved in step 4. On the H9642 cabinet, you must first mount the panel on the 74-28684-00 adaptor plate, which is then installed on the H349. Figure 2-6 shows the various possible combinations of panel and system box.
6. Prepare and install the M7656 module in accordance with the VSV21 Installation Manual, Section 2.3, steps 1 to 9 inclusive. On completion of step 9, turn the power OFF.
7. Connect the ribbon cable between J1 on the M7656 module and J1 on the bulkhead panel, making sure that the connectors match pin 1 with pin 1. Connect also the three coaxial cables between J2, J3, and J4 on the M7656 module and the bulkhead panel, making sure that the red cable connects to the red connector on the module (J2), and so for the blue cable (J3), and the green cable.
8. Fold any excess cable as shown in Figure 2-7.
9. If the VSV21 is to be used also as the console terminal, find the correct cable (VSV21-AC for a PDP host, or VSV21-AK for a P/VAX host) and connect it as shown in Figure 2-8, 2-9 or 2-10.
10. If the VSV21 is to be used as a terminal (not console) on the host system, find the correct cable (VSV21-AG) and connect it as shown in Figure 2-11, 2-12 or 2-13.
11. Connect the serial link cable to the bulkhead panel and to the remote interface box.
12. Connect the VSV21 to the color monitor by plugging the three SNC connectors of the video cable to the monitor. Make sure that the correct color connector is used for each color. The cable is color-coded red, green, and blue. Connect the other end of the cable to the

INSTALLATION PROCEDURE

VSV21 bulkhead panel, again matching the three colors against the panel marking (R = red, etc).

13. When the VSV21 is being used as a terminal (whether as a console or not) it will need the addition of a keyboard. An LK-201 keyboard must be available. Connect the keyboard cable jack-plug to the jack-socket on the remote interface box. If the keyboard is other than a USA version LK-201-AA, then the system software must know this. Further details on how to do this are contained in the VSV21 Installation Manual.
14. Connect the pointing device (if available) to the remote interface box as follows:

Note

Only one of PD1 and PD2 is to be used at any one time

- Non-DEC pointing device to the 25-way 'D' type connector marked PD1.
 - DEC pointing device to the Micro-DIN type connector marked PD2.
15. Check that the local ac mains supply is as shown on the rating plate on the remote interface box. Connect the ac mains supply cable to the remote interface box.
 16. Switch ON the ac mains supply to the remote interface box and check that the +5V LED on the box is lit. If the LED is not lit, momentarily press the +5V RESET pushbutton. If the LED does not then light and remain lit, and the pushbutton remain locked in, switch OFF the ac mains supply and check for a short circuit on the +5V external circuit. If no short circuit can be found, request a Service Engineer.

You are now ready to start the checkout procedure by running diagnostic programs. Chapter 3 describes the diagnostics philosophy and explains the preparations needed for running these tests.

2.2.5 Options VSV21-AP and AQ

Note

In the case of these options, the VSV21-AA module is already installed

1. Install the serial link and video cables in accordance with Section 2.2.2.
2. Install the remote interface box as detailed in Section 2.2.3.

INSTALLATION PROCEDURE

Figure 2-5 Bulkhead Panel for the VSV21 Peripheral Concentrator Option

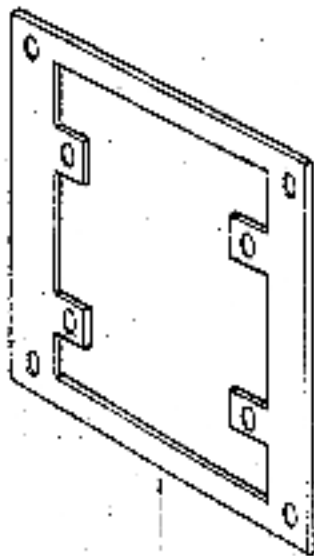

PANEL ADAPTOR
74-28664-30

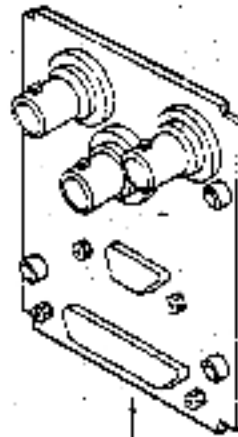

BULKHEAD PANEL
70-24334-31

INSTALLATION PROCEDURE

Figure 2-6 Bulkhead Panel Installed on System Boxes

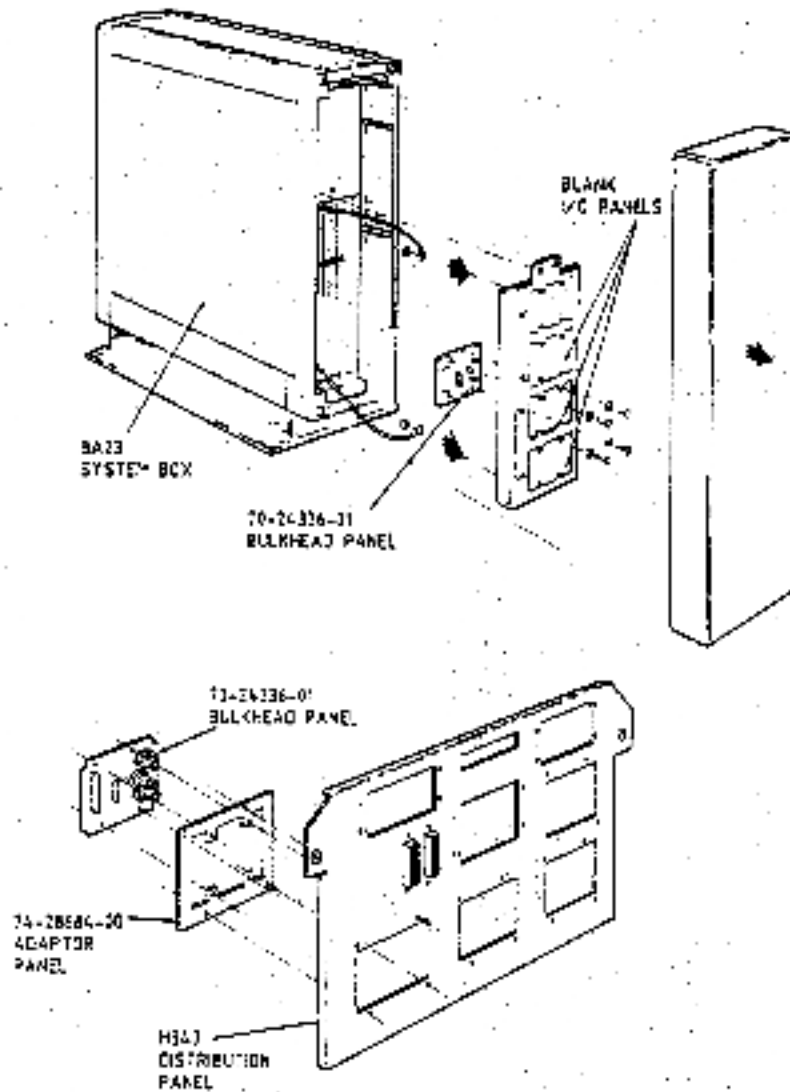

INSTALLATION PROCEDURE

Figure 2-7 Cable Layout

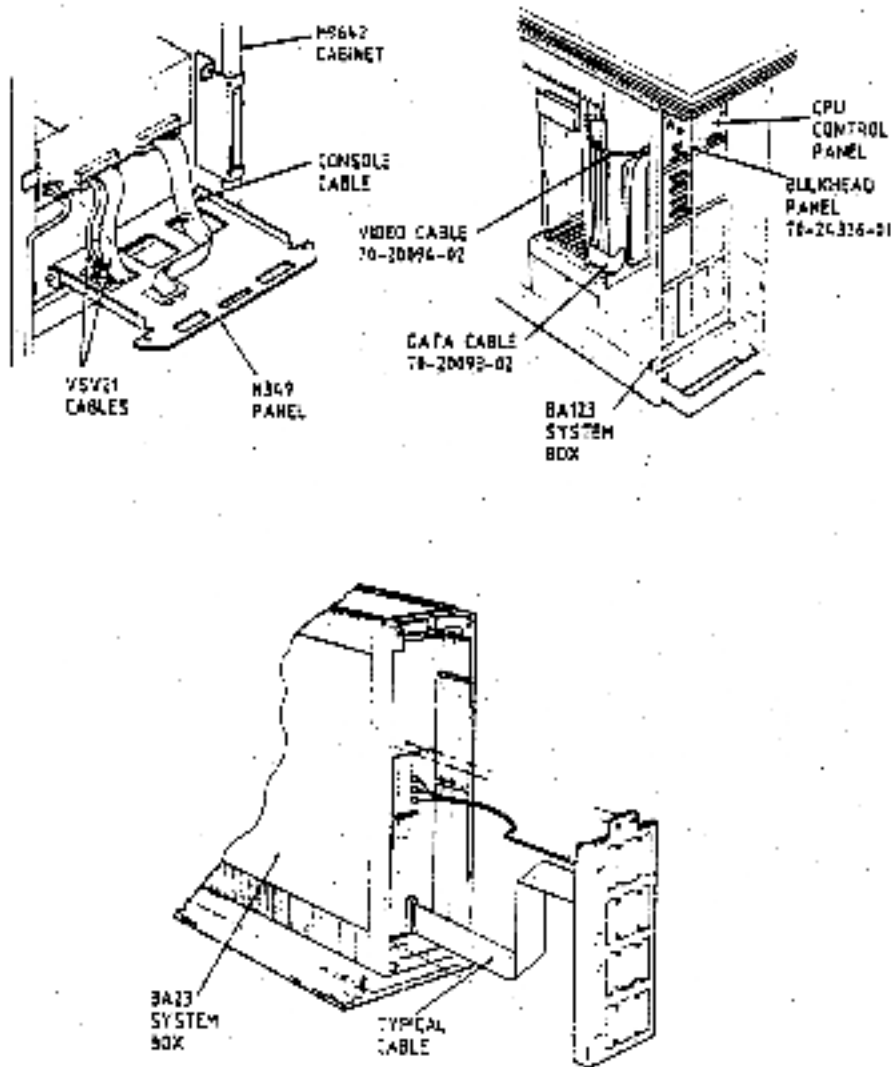

INSTALLATION PROCEDURE

Figure 2-8 Console Connection on BA11-S Systems

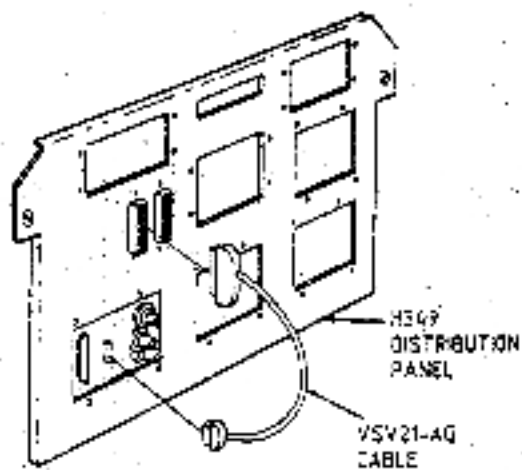

INSTALLATION PROCEDURE

Figure 2-9 Console Connections on BA23 Systems

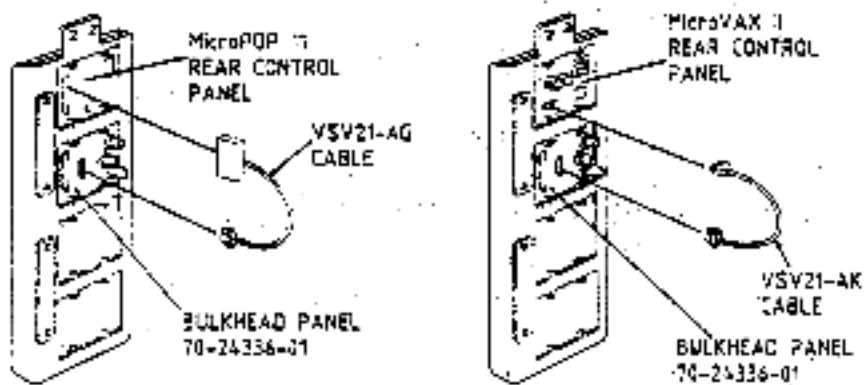

INSTALLATION PROCEDURE

Figure 2-10 Console Connections on BA123 Systems

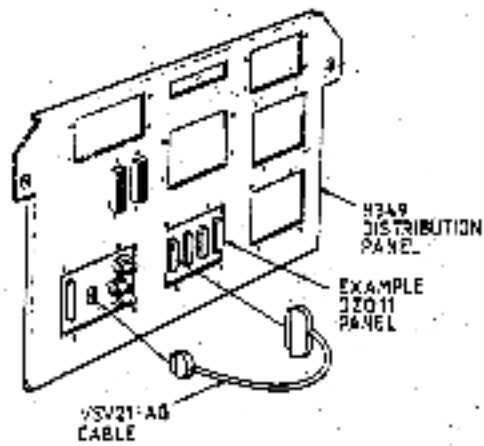

INSTALLATION PROCEDURE

Figure 2-11 Terminal Connection on BA11-S Systems

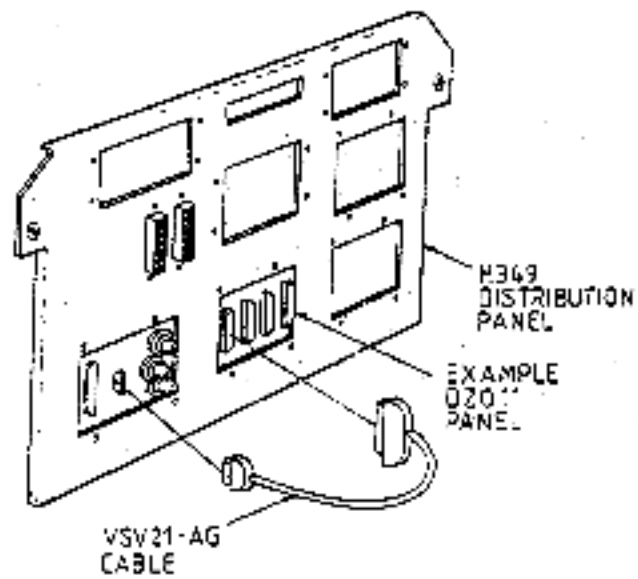

INSTALLATION PROCEDURE

Figure 2-12 Terminal Connections on BA23 Systems

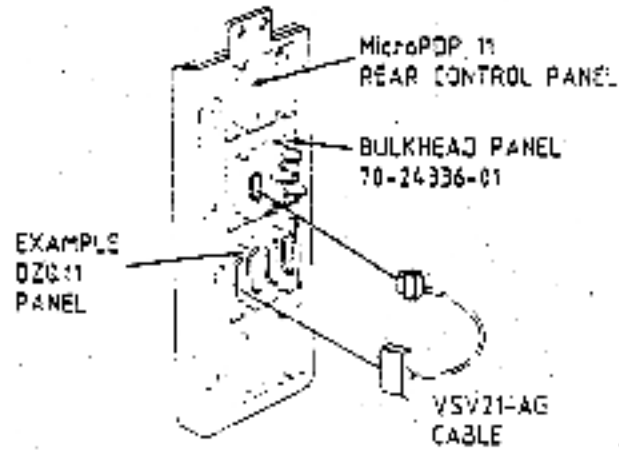

INSTALLATION PROCEDURE

Figure 2-13 Terminal Connections on BA123 Systems

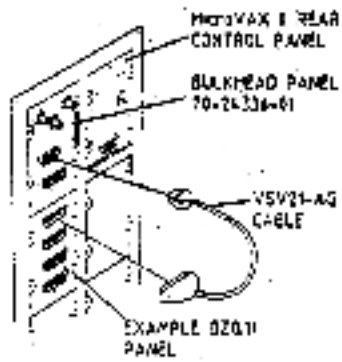

INSTALLATION PROCEDURE

- 3 Find the bulkhead panel 70-24336-01. Figure 2-5 shows this item.
- 4 Find the bulkhead panel currently connected to the M7656 module with which the option is to be associated. Remove all external connections to the panel, and the ribbon cable and three coaxial cables connecting the module and the panel (at the panel only).
- 5 Remove the panel, taking care to save the screws. On the H9642 cabinet, you must first remove the 74-28684-00 adaptor plate from the H349 connector panel, and then remove the bulkhead panel from the adaptor plate.
- 6 Mount the new bulkhead panel, using the screws saved in step 5. On the H9642 cabinet, you must first mount the panel on the 74-28684-00 adaptor plate, which is then installed on the H349. Figure 2-6 shows the various possible combinations of panel and system box.
- 7 Proceed as detailed in Section 2.2.4, steps 7 to completion.

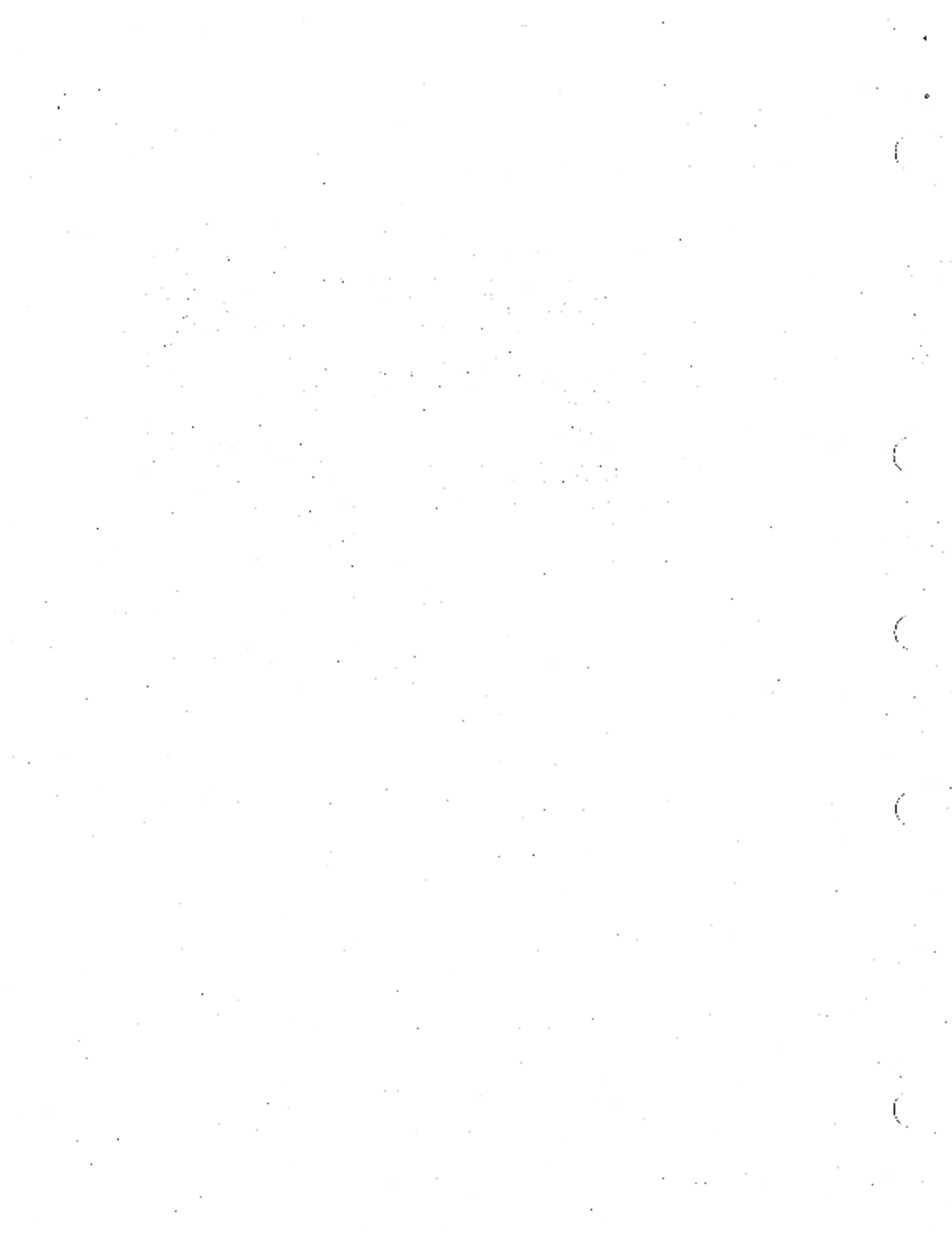

3

DIAGNOSTICS

3.1 GENERAL

This chapter contains a description of the diagnostic philosophy as used in the VSV21 product. Detailed instructions for running these diagnostics, and the error messages generated, are contained in Chapter 4.

3.2 MAINTENANCE STRATEGY

3.2.1 Preventative Maintenance

No preventative maintenance is planned for this option. However, if you are servicing the host system, examine the option for loose connectors and damaged cables.

3.2.2 Corrective Maintenance

Corrective maintenance is based on finding and replacing the defective field-replaceable unit (FRU). The device is not user-serviceable.

3.3 DIAGNOSTICS OVERVIEW

The diagnostics programs provided are intended to find faulty FRUs. They are not intended to find faulty parts smaller than an FRU.

Some of the diagnostics need loopback test connectors. The peripheral concentrator kit includes loopback connectors to test as far as the remote end of the data link cable. The VSV21 loopback kit must be taken on-site or obtained from Digital Equipment, as appropriate (VSV21-AJ).

The FRUs identified by the diagnostics are:

- The M7656 VSV21-AA module
- The 70-20091-01 bulkhead-mounting panel assembly (standard VSV21 option only)

DIAGNOSTICS

- The 70-24336-01 bulkhead-mounting panel assembly (peripheral concentrator option only)
- The remote interface box assembly
- The remote interface box power supply
- The 90-07212-00 remote interface box ac mains fuse
- The 70-20093-xx data cable assembly
- The 70-20094-xx video cable assembly
- The 12-10929-07 +12-volt peripheral device fuse F1
- The 12-10929-07 +5-volt peripheral device fuse F2

3.3.1 The Power-Up Self-Test (VSV21-AA Module)

This test runs without intervention from the operator. When successfully completed, it provides a high level of confidence that the VSV21 can operate as a limited function VT-100, and can sufficiently control and respond to the Q-bus interface, so that it can understand and begin to run additional host-based diagnostic software. Until the Q-bus/host interface is proved, test results are indicated by on-board LED lights.

The VSV21-AA (M7656) module has a green LED and a red LED to indicate the results of self-test. When the module is powered up, both LEDs are ON. The self-test program first checks:

- The basic operation of the 68000 microprocessor
- The interfacing to the device status register

If either of these tests fails, both LEDs stay ON. If the tests are successful, the green LED goes OFF and the following checks are made:

- PROM checksum test
- NVRAM (non-volatile RAM) test
- RAM read and write test (by memory bank)
- 68000 microprocessor instruction set
- Serial-line communications (UARTs) with internal loopback
- Interface to the graphics processor
- Setting up the graphics processor from configuration switches
- Pixel memory read and write (by memory bank)

DIAGNOSTICS

- Screen self-test

The last test (screen self-test) is intended for initial adjustment of the color monitor, and also as a test pass indicator.

If all these tests are successful, the green LED comes ON and the red LED goes OFF. Otherwise the previous condition stays. LED timings and the displayed picture are described in more detail in Section 4.1.

At this point you have the option to select the type of LK201 used on the VSV21, by entering a specific code via the keyboard. Refer to the VSV21 Installation Manual for detailed procedure.

You can run each of these tests separately by using the host-based diagnostics. When this is done, the LEDs do not reflect the result of the tests.

3.3.2 Host-Based Diagnostics

These host-based routines perform more intensive tests of individual hardware and on-board software areas, and interfaces of the VSV21. All results are indicated via the VSV21/host interface.

In order to run the host-based diagnostics successfully, you must configure the VSV21 as a non-console device, and have a separate console terminal on the system. You cannot test the VSV21 and, at the same time, use it as a console terminal for providing error messages and other diagnostic information.

The host-based diagnostics are designed to run under the XXDP+ monitor for PDP-11 systems (ZVSWB?), or under the VAX-MDM for MicroVAX systems. The diagnostics are distributed in a package which is available on various media. The medium must be compatible with the system. In addition, an exerciser module (CXVSA) is available to run under DECX/11.

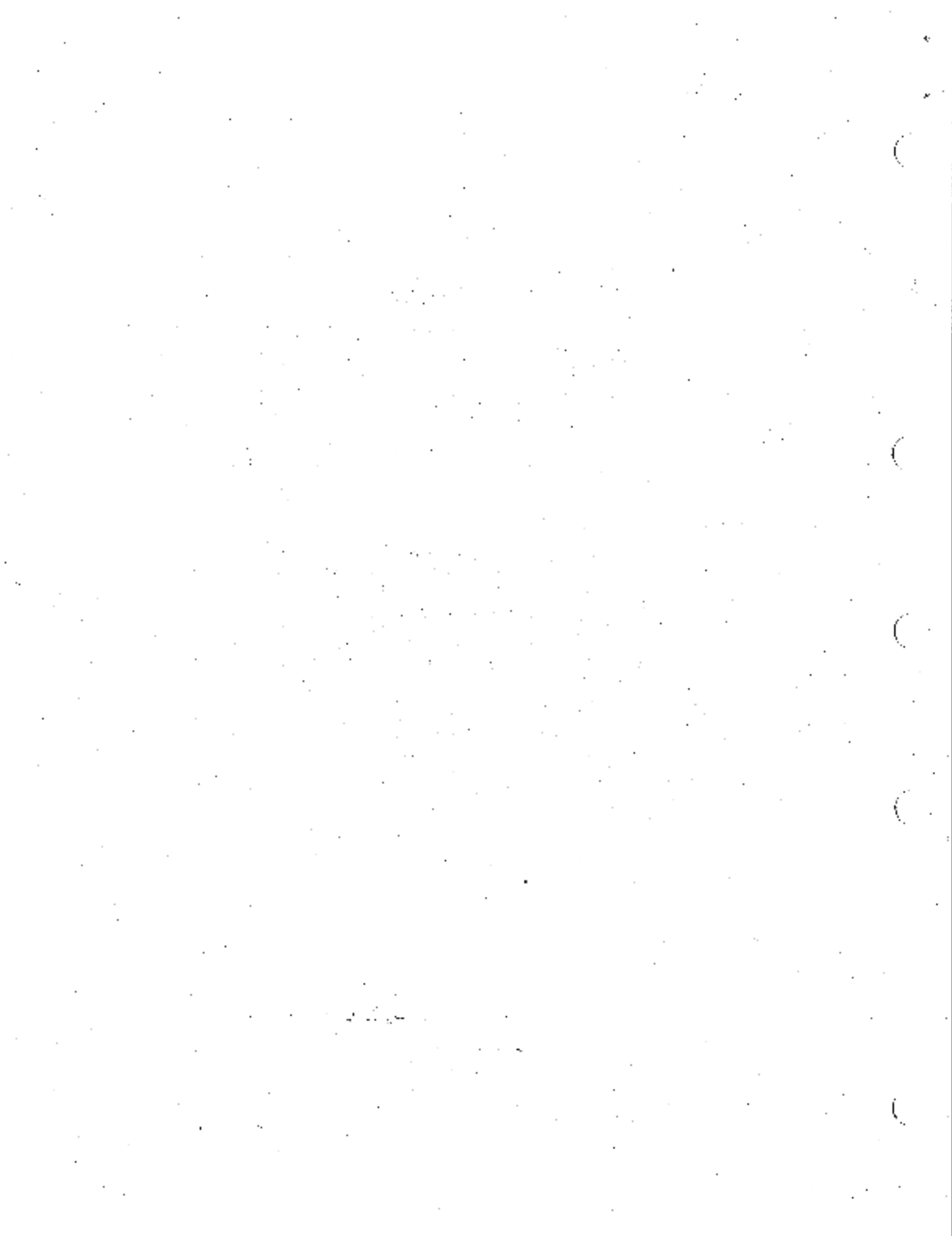

4

CHECKOUT AND ACCEPTANCE

4.1 ON-BOARD DIAGNOSTIC

4.1.1 Test Indications

Make sure that a color monitor is connected to the VSV21 module, as described in Section 2.2.3, step 11. Make sure also that the system power is switched OFF. Observe the M7656 LEDs and switch the system power ON. Both green and red LEDs should come on. After about one second the green LED will go OFF and the red LED will stay ON. This indicates that the M7656 module has passed the first stage of testing.

After another four seconds, the green LED will come ON again, and the red LED will go OFF. This indicates that the module has passed the second stage of testing (see Figure 4-1). Examine the monitor display. It must show a picture like that in Figure 4-2 overleaf. If the picture is unstable, if the circle is distorted, or if the white border is not centered, then you need to adjust the monitor controls as described in the manufacturer's documentation.

If the displayed picture is incorrect, check the video 3-color cable and all the associated connections, and check the monitor as described in Section 4.1.2. If the picture is still incorrect, or if the LEDs indicate that a failure has occurred during this stage, you must replace the M7656 module.

When tests are completed without failure, you have the option of defining the version of LK201 keyboard attached to the VSV21, so that it will be correctly interpreted. Refer to the VSV21 Installation Manual.

You can now run the host-based diagnostics.

CHECKOUT AND ACCEPTANCE

Figure 4-1 On-Board Diagnostic LED Indication

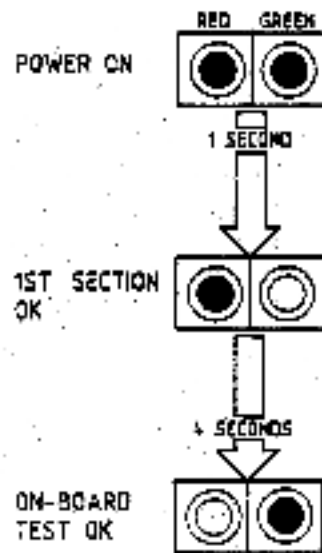

CHECKOUT AND ACCEPTANCE

4.1.2 Monitor Adjustment

When the on-board diagnostics have completed without an indication of failure, the test display picture should appear on the monitor screen. This picture provides a white border all round the screen, with a yellow circle in the middle, as shown in Figure 4-2.

If you are using a non-DEC monitor, refer to the manufacturer's documentation if any adjustment is needed.

If the monitor is a DIGITAL VR241-A and any adjustment is needed, consult the VR241-A Video Monitor Installation Manual.

4.2 HOST-BASED DIAGNOSTICS

4.2.1 XXDP+ Diagnostic Programs

The following tests are performed under the XXDP+ Ver.2 Supervisor by the VSV21 diagnostic ZVSWB:

- 1 VERIFY
This test verifies the presence of the VSV21.
- 2 IN-DEPTH-Q22
This is an extensive test of DMA.
- 3 FORCED-ERROR
Error bit test.
- 4 ROM-CHECKSUM-TEST
Tests the integrity of the ROM.
- 5 NVRAM-CHECKSUM-TEST
Tests the integrity of the non-volatile RAM.
- 6 RAM-TEST
- 7 RAM-ADDRESSING-TEST
- 8 68000-PROCESSOR-TEST
- 9 INTERNAL-EXCEPTIONS-TEST
- 10 ACRTC-INTERNAL-TEST
(ACRTC = Advanced CRT Controller)
- 11 ACRTC-EXTERNAL-TEST

CHECKOUT AND ACCEPTANCE

Figure 4-2 Self-Test Picture

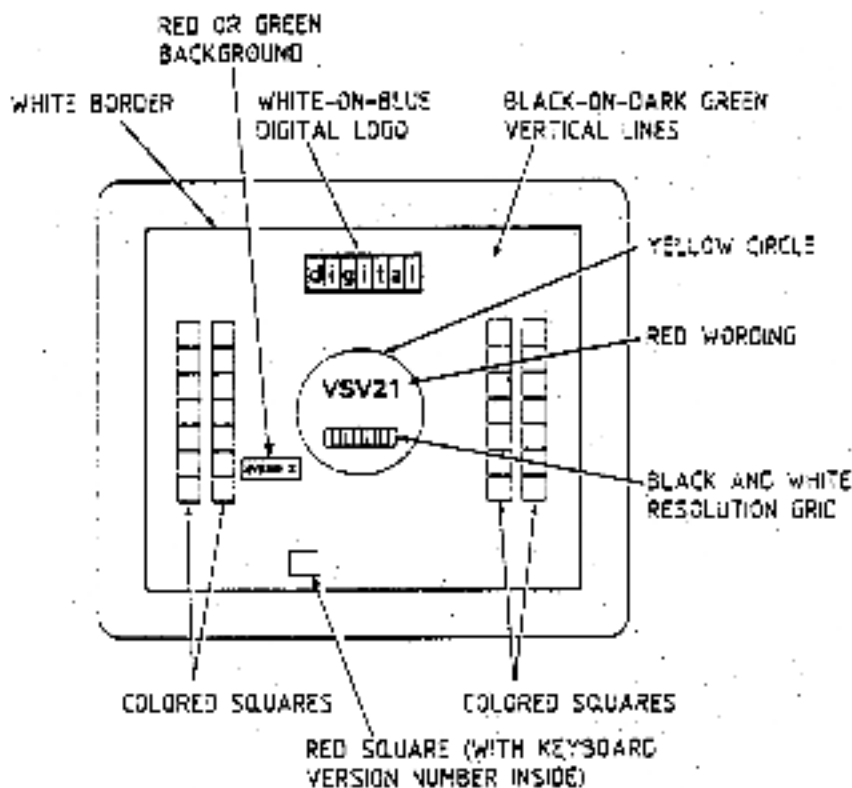

CHECKOUT AND ACCEPTANCE

- 12 DUART-BASIC-TEST
(DUART - Dual Universal Async Receiver Transmitter).
- 13 DUART-FULL-TEST
- 14 FULL-ON-BOARD-TEST
This test runs the on-board diagnostics.
- 15 INTERNAL-LOOPBACK-TEST
- 16 EXTERNAL-NO-LOOPBACK-TEST
- 17 NVRAM-READ/WRITE-TEST
- 18 DISPLAY-PICTURES-TEST
This test outputs a selected screen color or pattern to the monitor.
- 19 KEYBOARD CONFIDENCE TEST
- 20 POINTING DEVICE CONFIDENCE TEST
- 21 PERIPHERALS-CONFIDENCE
This test inputs or outputs data to selected peripherals.
- 22 CONTROL-PARAMETERS-RESET
This is not really a test but a function used mainly at the factory and for resetting the NVRAM in the field.

4.3 RUNNING PDP-11 DIAGNOSTICS

Note

You cannot run host-based diagnostics on the VSV21 when it is configured as the system console. You should connect another terminal to the host system to act as system console instead.

The standard VSV21 diagnostic reports any loss of data connection between the host module and its peripherals with a "TIMEOUT" error message. If while running data input tests (Tests 19, 20 and 21) the diagnostic receives no data within 15 seconds of the test being commanded, the diagnostic issues the "TIMEOUT" error message and halts.

When the peripheral concentrator is part of the system configuration, the peripherals are remote from the host processor and the console device which displays the diagnostic results. To avoid a "TIMEOUT" due to the time taken by the operator to get from the console device to the remote data input peripherals, the following diagnostic command string is used:

CHECKOUT AND ACCEPTANCE

STA/FLA:LOE/TEST:1-2:xx/PASS:1

where xx is the test number.

This allows time for the operator to go between the console device and the remote peripheral and check for good data input.

To run the diagnostic package:

- 1 Fit the loopback test connectors to ports PD1, K3D and AUX on the Peripheral Concentrator and the VSV21 host port on the bulkhead panel.
Port PD1 requires loopback Part Number 12-15336-01.
- 2 Boot XXDP+ Ver.2.
- 3 The system responds with the display:

```
XXDP-6M SMALL MONITOR VER.2
```

```
.....
```

```
THIS IS XXDP-6M TYPE "S" OR "H/L" FOR HELP
```

- 4 Type:

```
R ZVSWB?
```

to load and run the VSV21 diagnostic.

The Diagnostic Runtime Service is loaded, and the program started. A message similar to the following is output:

```
DRSSM-F0
```

```
CZVSWB?-A-0
```

```
VSV21 DIAGNOSTIC
```

```
UNIT IS VSV21
```

```
RSTAT ADDR ????????
```

```
DR>
```

- 5 At the DR> prompt, type:

```
STA/FLA:UAM
```

- 6 Answer Y to the "CHANGE H/W (L)?" query.
- 7 In answer to the "# UNITS (E)?" prompt, type the number of units under test.
- 8 Type the address and the vector for each unit under test. (See VSV21 Installation Manual.)

CHECKOUT AND ACCEPTANCE

The program asks if you want to change the software. This allows you to run the tests without interrupts enabled. If you want this option, answer Y(es) to the query.

The diagnostic tests now start to test the VSV21 module(s) and execute the non-intervention tests 1 to 16. At the end of each pass, the pass error-count is printed. Allow at least three error-free passes to complete before you continue the test.

- 9 Press CTRL/C to return the diagnostic to command mode.

You can now request the manual-intervention tests relevant to the peripheral concentrator. They are:

- Test 18 - Screen Test
- Test 19 - Keyboard Confidence Test
- Test 20 - Pointing Device Confidence Test
- Test 21 - Peripheral Confidence Test

Test 18—Display Test Pictures

This test generates and displays selected pictures on the monitor screen.

At the DR> prompt, type:

STA/PASS:1/TEST:1-2:18

The program asks if you want to change the hardware, and then asks if you want to change the software. If you answer Y(es) to either query, the effect is as previously described. If you answer N(o) to both queries, the diagnostic starts the execution of the test and asks the following question:

PICTURE NUMBERS ARE:

- 0 = FINISH THIS TEST
- 1 = RED SCREEN
- 2 = GREEN SCREEN
- 3 = BLUE SCREEN
- 4 = WHITE SCREEN
- 5 = CROSS HATCH AND CIRCLE (HIGH RESOLUTION SCREEN)
- 6 = CROSS HATCH AND CIRCLE (LOW RESOLUTION SCREEN)
- 7 = VERTICAL GOLD BARS
- 8 = VERTICAL GREY SCALE BARS

PLEASE INPUT PICTURE NUMBER

CHECKOUT AND ACCEPTANCE

Pictures number 5 and 6 display a cross-hatched screen with a circle in the centre. Picture number 5 is for high-resolution monitors and picture number 6 is for low-resolution monitors.

Type the number you want and press the RETURN key.

Examine the picture displayed on the monitor screen. If necessary, use this to make any adjustments to the monitor. You can repeat the test to select any other test picture you need.

Test 19—Keyboard Confidence Test

This test displays the ASCII code (in octal) of the first six keys depressed after the test is started. You can verify the codes by comparing them with the information in the ZVSWB0 list file or the Table in Appendix A.

At the DR> prompt, type:

```
STA/FLA:LDE/TEST:1-2:19/PASS:1
```

The program asks if you want to change the hardware, and then asks if you want to change the software. If you answer Y(es) to either query, the effect is as previously described. When the changes are completed, or if you answer N(o) to both questions, the program responds with the following message:

```
--AN ON-BOARD ERROR WILL HANG THIS TEST INDEFINITELY==  
DUE TO ON-BOARD LDE FLAG SET - DO YOU WISH IT SET ? (L) ?:
```

If you answer Y(es), the diagnostic starts execution of the test.

Press the six keys.

Test 20—Pointing Device Confidence Test

This test allows you to test the Measurement Systems Inc. joystick when such a device is attached to the system being tested.

At the DR> prompt, type:

```
STA/FLA:LDE/TEST:1-2:20/PASS:1
```

The program asks if you want to change the hardware, and then asks if you want to change the software. If you answer Y(es) to either query, the effect is as previously described. When the changes are completed, or if you answer N(o) to both questions, the program responds with the following message:

CHECKOUT AND ACCEPTANCE

--AN ON-BOARD ERROR WILL HANG THIS TEST INDEFINITELY--
DUE TO ON-BOARD LOE FLAG SET - DO YOU WISH IT SET ? (L)?:

If you answer Y(es), the diagnostic starts execution of the test.

The test expects you to activate the pointing device and displays six consecutive values of X and Y from the device. You must not interpret these values numerically. You should only examine the sign of X and Y in order to determine if the correct quadrant is indicated.

Test 21—Peripheral Device Confidence Test

This test is a general purpose peripheral confidence test, which allows you to select a port.

At the DR> prompt, type:

```
STA/FLA:LOE/TEST:1-2:21/PASS:1
```

The program asks if you want to change the hardware, and then asks if you want to change the software. If you answer Y(es) to either query, the effect is as previously described. When the changes are completed, or if you answer N(o) to both questions, the program responds with the following message:

--AN ON-BOARD ERROR WILL HANG THIS TEST INDEFINITELY--
DUE TO ON-BOARD LOE FLAG SET - DO YOU WISH IT SET ? (L)?:

If you answer Y(es), the diagnostic starts execution of the test.

Port 0 = Keyboard port, 4-way jack
Port 1 = Host port, 9-pin D-type
Port 2 = Pointing device port, 25-pin D-type/MicroDIN
Port 3 = Serial port, 9-pin D-type

If output is selected, then the test will output a fixed ASCII string as follows:

```
01$#*%* (+_2143658709WQREYTHUPD){safdhgk};1
```

If input is selected, the first 16 characters input to the port are displayed on the console running the test.

This test should only be run when there is no specific test for the peripheral device.

When all these tests have successfully been run, the installation checkout of the VSV21 is complete.

CHECKOUT AND ACCEPTANCE

Press CTRL/C to return the diagnostic to the DR> prompt.

4.4 RUNNING μ VAX MDM DIAGNOSTICS

Note

You cannot run host-based diagnostics on the V3V21 when it is configured as the system console. You should connect another terminal to the host system to act as system console instead.

The following tests are available for the μ VAX installation:

- Functional Tests
 - 1v - In-Depth Q22 Bus Test
 - 2v - ROM Checksum Test
 - 3v - NVRAM Checksum Test
 - 4v - RAM Test
 - 5v - RAM Addressing Test
 - 6v - 68000 Processor Test
 - 7v - Internal Exceptions Test
 - 8v - ACRTC Internal Test
 - 9v - ACRTC External Test
 - 10v - Illegal Command Test
 - 11s - Basic DUART Test (Loopback connectors needed)
 - 12s - Full DUART Test (Loopback connectors needed)
 - 13s - Full On-Board Test (Loopback connectors needed)
 - 14s - Internal Loopback Test (Loopback connectors needed)
 - 15s - External Loopback Test (Loopback connectors needed)
- Exerciser Tests
 - 1v - Verify DMA Test
 - 2v - Verify Screen Exerciser
 - 3s - Service Exerciser
- Utilities
 - 1 - Monitor Test Picture

CHECKOUT AND ACCEPTANCE

- 2 - NVRAM Reset Utility
- 3 - On-Board Error Control Options
- 4 - Peripheral Confidence Test Utility
- 5 - Keyboard Confidence Test
- 6 - MSI Pointing Device Test Utility
- 7 - NVRAM Read/Write Test
- 8 - VSV21/90 Selection Utility

The standard VSV21 diagnostic reports any loss of data connection between the host module and its peripherals with a "TIMEOUT" error message. If while running data input tests (Utility Tests 4, 5 and 6) the diagnostic receives no data within 15 seconds of the test being commanded, the diagnostic issues the "TIMEOUT" error message and halts.

When the peripheral concentrator is part of the system configuration, the peripherals are remote from the host processor and also the console device which displays the diagnostic results. To avoid a "TIMEOUT" due to the time taken by the operator to get from the console device to the remote data input peripherals, the diagnostic for the VSV21 peripheral concentrator option includes the facility for the operator to extend the timeout period as required by responding to the appropriate prompt as described below for Tests 4, 5 and 6.

Of the tests listed above, the following are relevant to the VSV21 peripheral concentrator:

- Functional Tests
 - Test 1—In Depth Q22
This is an extensive test of DMA.
 - Test 15—External Loopback Test
- Utilities
 - Test 1—Display Test Pictures
This test generates and displays selected pictures on the monitor screen.
On commencement of the test, the diagnostic asks the following question:

CHECKOUT AND ACCEPTANCE

Picture numbers:

- 0 = Finish this test
- 1 = Red screen
- 2 = Green screen
- 3 = Blue screen
- 4 = White screen
- 5 = Cross hatch & circle (Hi res)
- 6 = Cross hatch & circle (Lo res)
- 7 = Vertical color bars
- 8 = Vertical grey scale bars (VSV21 only)
- 9 = 256 color VSV90 display (Lo res VSV90 only)
- 10 = 256 color VSV90 display (Hi res VSV90 only)

Please input picture number

Pictures number 1 to 5 inclusive and 8 are for VSV21 only. Pictures number 3 and 6 display a cross-hatched screen with a circle in the centre. Picture number 5 is for high-resolution monitors and picture number 6 is for low-resolution monitors. Picture number 9 is for low-resolution VSV90 only and picture number 10 is for high-resolution VSV90 only.

Type the number you want and press the RETURN key.

Examine the picture displayed on the monitor screen. If necessary, use this to make any adjustments to the monitor. You can repeat the test to select any other test picture you need.

- Test 4—Peripheral Device Confidence Test

This test is a general purpose peripheral confidence test, which allows you to select a port.

When you start the test, the diagnostic prompts:

"Enter the time you require to complete the test in seconds
[0:15]"

Type the time you require and press the RETURN key.

Port 0 = Keyboard port, 4-way jack

Port 1 = Host port, 9-pin D-type

Port 2 = Pointing device port, 25-pin D-type/MicroDIM

Port 3 = Serial port, 9-pin D-type

If output is selected, then the test will output a fixed ASCII string as follows:

```
0!$%&'()*(-_2143567890REY?TUPQ){|@!d!hgk}:1
```

If input is selected, the first 16 characters input to the port are displayed on the console running the test.

CHECKOUT AND ACCEPTANCE

This test should only be run when there is no specific test for the peripheral device.

When all these tests have successfully been run, the installation checkout of the VSV21 is complete.

— Test 5—Keyboard Confidence Test

This test displays the ASCII code (in octal) of the first six keys depressed after the test is started. You can verify the codes by comparing them with the information in the table in Appendix A.

When you start the test, the diagnostic prompts:

"Enter the time you require to complete the test in seconds
[D:15]"

Type the time you require and press the RETURN key.

Then press the six keys.

— Test 6—Pointing Device Confidence Test

This test allows you to test the Measurement Systems Inc. joystick when such a device is attached to the system being tested.

When you start the test, the diagnostic prompts:

"Enter the time you require to complete the test in seconds
[D:15]"

Type the time you require and press the RETURN key.

The test expects you to activate the pointing device and displays six consecutive values of X and Y from the device. You must not interpret these values numerically. You should only examine the sign of X and Y in order to determine if the correct quadrant is indicated.

Table 4-1 shows which tests are suggested for the peripheral concentrator under the different MDM modes.

Table 4-1 Diagnostic Tests Under MDM

Test	Verify Mode	Service Mode
Functional Tests		Tests 1 and 16
Exercise Tests		Tests 1, 2 and 3
Utility Tests	Tests 1, 4, 5 and 6	



A

LK-201 KEYBOARD CODES

This appendix provides information about the LK-201 keyboard key layout (Figure A-1), and the associated codes generated by each key when depressed (Table A-1).

LK-201 KEYBOARD CODES

Figure A-1 Layout of an LK-201 Keyboard

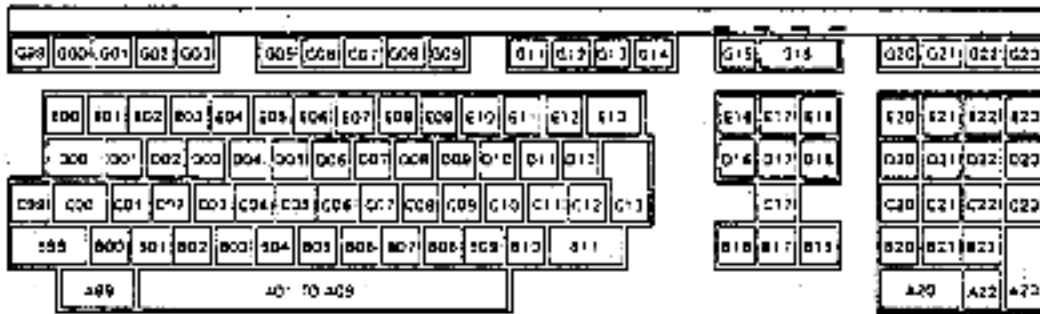

LK-201 KEYBOARD CODES

Table A-1 LK-201 Decimal Codes

Key Position	Decimal Code	Key Position	Decimal Code
G00	086	E18	140
G00	087	E20	161
G01	088	E21	162
G02	089	E22	163
G03	090	E23	164
G05	100	C00	190
G06	101	C01	193
G07	102	C02	198
G08	103	D03	204
G09	104	D04	209
G11	113	D05	215
G12	114	D06	220
G13	115	D07	225
G14	116	D08	230
G15	124	D09	235
G18	125	D10	240
G20	126	D11	250
G21	128	D12	246
G22	130	D16	141
G23	131	D17	142
E00	191	Q18	143
E01	192	Q20	157
E02	197	Q21	158
E03	203	Q22	159
E04	208	Q23	160
E06	214	C99	175

LK-201 KEYBOARD CODES

Table A-1 (Cont.) LK-201 Decimal Codes

Key Position	Decimal Code	Key Position	Decimal Code
E08	219	C20	175
E07	224	C01	194
E09	234	C02	199
E10	239	C03	205
E11	248	C04	210
E12	245	C05	216
E13	188	C06	221
E16	138	C07	226
E17	139	C08	231
C09	236	B09	237
C10	242	B10	243
C11	251	B14	157
C12	247	B17	169
C13	189	B18	166
C17	170	B20	150
C20	153	B21	151
C21	154	B22	152
C22	155	A99	177
C23	156	A01-A09	212(SPACE BAR)
B99	174	A20	146
B00	201	A22	148
B01	196	A23	149
B02	200		
B03	206		
B04	211		
B05	217		
B06	222		

LK-201 KEYBOARD CODES

Table A-1 (Cont.) LK-201 Decimal Codes

Key Position	Decimal Code	Key Position	Decimal Code
B07	227		
B08	232		

