

LNV21-SF Controller

Installation/Owner's Manual

Prepared by
Computer Special Systems

1st Edition November, 1988

© Digital Equipment Corporation 1988
All Rights Reserved

The information in this document is subject to change without notice and should not be construed as a commitment by Digital Equipment Corporation. Digital Equipment Corporation assumes no responsibility for any errors that may appear in this document.

Printed in U.S.A.

This document was produced using the DIGITAL DECpage text processing product. Book production was done by Computer Special Systems Documentation Services in Merrimack, NH.

The following are trademarks of Digital Equipment Corporation:

digital™

DATATRIEVE

DEC

DECmate

DECset

DECsystem-10

DECSYSTEM-20

DECUS

DECwriter

DIBOL

IVAX

MASSBUS

PDP

P/OS

Professional

Rainbow

RSTS

RSX

Scholar

ULTRIX

UNIBUS

VAX

VMS

VF

Work Processor

Table of Contents

List of Figures	v
List of Tables	vii
Preface	ix
CHAPTER 1 DESCRIPTION	1
1.1 INTRODUCTION	1
1.2 LNV21-SF CONTROLLER OPTION	1
1.2.1 M8087 Module	1
1.2.2 Gap Fillers (P/N 70-24505-01)	4
1.2.3 Loopback Cable (P/N 17-02250-01)	6
1.3 BA213 MICRO SYSTEM ENCLOSURE	6
1.4 LNV21-SF CONTROLLER SPECIFICATIONS	10
CHAPTER 2 INSTALLATION	13
2.1 INTRODUCTION	13
2.2 UNPACKING THE MODULE	13
2.3 SYSTEM SOFTWARE	16
2.3.1 System Software Backup	16
2.3.2 System Software Shutdown	16
2.4 CONFIGURATION	17
2.4.1 System Configuration	17
2.4.2 Configuring the M8087 Module	21
2.5 TESTING THE EXISTING SYSTEM	28

2.6 RELOCATING EXISTING MODULES	29
2.6.1 Modules with Blank Covers	29
2.6.2 Modules with Handles	31
2.7 INSTALLING THE M8087 MODULE	33
2.8 VERIFYING THE GROUND CONNECTIONS	35
2.9 TESTING THE SYSTEM	38
2.10 CONNECTING EXTERNAL DEVICES	39
2.10.1 Laser Printer	39
2.10.2 Scanner	39
CHAPTER 3 MicroYAX DIAGNOSTICS MONITOR	41
3.1 INTRODUCTION	41
3.2 RUNNING THE MDM	43
3.2.1 MDM Introductory Screen	43
3.2.2 Main Menu Options	44
3.2.2.1 Test the System	45
3.2.2.2 Select Single Device Tests	46

List of Figures

Figure 1-1	M8087 Module	2
Figure 1-2	M8087 Module, Cables, Laser Printer and Scanner	3
Figure 1-3	Gap Fillers	4
Figure 1-4	Loopback Cable	6
Figure 1-5	BA213 Enclosure	7
Figure 1-6	BA213 Handles and Covers	9
Figure 2-1	LNV21-SF Controller Option Shipping Contents	15
Figure 2-2	VAXstation 3500 System Q22-Bus	18
Figure 2-3	Backplane Map for VAXstation Model VS350-AA	19
Figure 2-4	Backplane Map for VAXstation Model VS355-AA	19
Figure 2-5	BA213 Enclosure Configuration Worksheet	20
Figure 2-6	M8087 Module and Jumpers Locations	23
Figure 2-7	Releasing the Captive Screws	30
Figure 2-8	Unlocking the Release Levers	32
Figure 2-9	Inserting the M8087 Module	34
Figure 2-10	Ground Connections	36
Figure 2-11	Attaching the Gap Filler Assembly	37
Figure 2-12	Typical External Device Cable	39
Figure 2-13	External Device Connectors on the M8087 Module	40

List of Tables

Table 1-2 LNV21-SF Controller Specifications	10
Table 2-1 M8087 Module Factory Preset Jumpers	22
Table 2-2 M8087 Module User Selectable Jumpers	22

100-100000

100-100000

Preface

The *LN21-SF Controller Installation/Owner's Manual* provides the information needed to configure, install, and test the LN21-SF Controller in a VAXstation 3500 workstation.

The LN21-SF Controller consists of a quad-height module (M8087) and a loop-back cable (to be used by DIGITAL™ Field Service personnel and qualified self-maintenance customers only).

This manual is intended for DIGITAL Field Service personnel and qualified self-maintenance customers who have purchased the MicroVAX System Maintenance Kit (Order Number ZNABX-GZ, C6).

For the Customer

If you are not qualified to perform the installation of the M8087 module, call DIGITAL Field Service to schedule an installation.

CAUTION

If you are qualified to perform the installation of the M8087 controller module, use an antistatic wrist strap and antistatic mat connected to a grounded workstation before handling the modules. The system modules are susceptible to damage by static discharge.

To install the M8087 module, carefully follow the installation procedure in Chapter 2. If you have any difficulty performing the installation, call DIGITAL Field Service for assistance.

For Field Service

CAUTION

Be sure to take antistatic precautions when installing the new module. Use the wrist strap and antistatic mat found in the Antistatic Kit (P/N 29-20246-00). (The Antistatic Kit is not included in this installation kit. It is part of the Field Service Tool Kit.)

To install the LNV21-SF Controller, carefully follow the installation procedure in Chapter 2.

If the system configuration differs from that shown in Chapter 2, Figures 2-3 and 2-4, use the configuration worksheet shown in Figure 2-5 to determine whether the installation of the option module exceeds the power requirements and bus load requirements for the VAXstation 3500 system.

When you have completed the installation, submit a LARS form. For information on completing this form, contact your unit manager.

MANUAL ORGANIZATION

This manual is organized into three chapters. The contents of each chapter is briefly described below:

- **CHAPTER 1, DESCRIPTION** — Describes the LNV21-SF Controller and the BA213 series micro system enclosures. Shows a typical Q22-bus backplane, and provides the specifications for the LNV21-SF Controller.
- **CHAPTER 2, INSTALLATION** — Describes unpacking the LNV21-SF Controller, system and M8087 module configuration, verifying the existing system, relocating existing modules, verifying the ground connections, installing the M8087 module, and connecting external devices.
- **CHAPTER 3, TESTING THE NEW CONFIGURATION** — Describes the procedures for testing and troubleshooting the LNV21-SF Controller using the MicroVAX Diagnostic Monitor (MDM) diagnostic.

RELATED DOCUMENTATION

Title	Order No.
<i>MD300 Scanner Installation/Owner's Manual</i>	EK-MD300-IN
<i>MD300 Scanning Subsystem Pocket Service Guide</i>	EK-MD300-PS
<i>MicroVAX Diagnostics Monitor User's Guide</i>	AA-FM7AB-DN
<i>MicroVAX System Maintenance Guide</i>	EK-001AA-MG
<i>MicroVAX Troubleshooting and Diagnostic Manual</i>	EK-019AA-SG

DIGITAL personnel may order documents from:

Digital Equipment Corporation
10 Forbes Road
Northboro, MA 01582

Attention: Publishing and Circulation Services (NR03/W3)
Order Processing Section

Customers may order documents from:

Digital Equipment Corporation
Peripherals and Supplies Group
P.O. Box CS2008
Nashua, NH 03081

CONVENTIONS

Where notes, cautions, and warnings are used in this document, they highlight specific types of information as follows:

NOTE

A note calls the reader's attention to any item of information that may be of special importance.

CAUTION

A caution contains information essential to avoiding damage to the system.

WARNING

A warning contains information essential to the safety of personnel.

FCC USER STATEMENT

NOTICE:

This equipment generates, uses, and may emit radio frequency energy. The equipment has been type tested and found to comply with the limits for a Class A computing device pursuant to Subpart J of Part 15 of FCC rules, which are designed to provide reasonable protection against such radio frequency interference. Operation of this equipment in a residential area may cause interference in which case the user at his own expense will be required to take whatever measures may be required to correct the interference.

CHAPTER 1 DESCRIPTION

1.1 INTRODUCTION

This chapter describes the LNV21-SF Controller and the BA213 Micro system enclosure. This chapter also lists the LNV21-SF Controller specifications.

1.2 LNV21-SF CONTROLLER OPTION

The LNV21-SF Controller is an option that can be used with VAXstation 3500 systems, which provides a means to connect a laser printer or scanner to the workstation. This section discusses the components that comprise the LNV21-SF Controller option. These components include the module (M8087), gap fillers, and a loopback cable.

1.2.1 M8087 Module

The M8087 module is a quad-height Printed Circuit Board (PCB), and provides connections to external devices (see Figure 1-1). These connectors provide connections to a laser printer and a scanner. Figure 1-2 shows how the M8087 module, cables, laser printer, and scanner are interconnected.

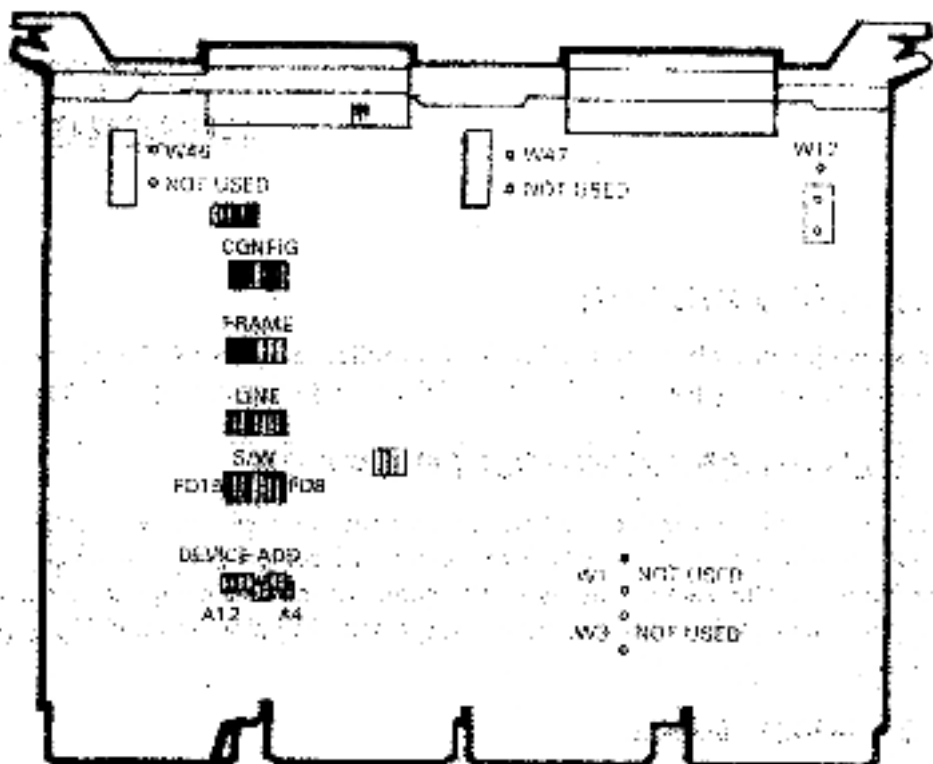

CS-7141

Figure 1-1 M8087 Module

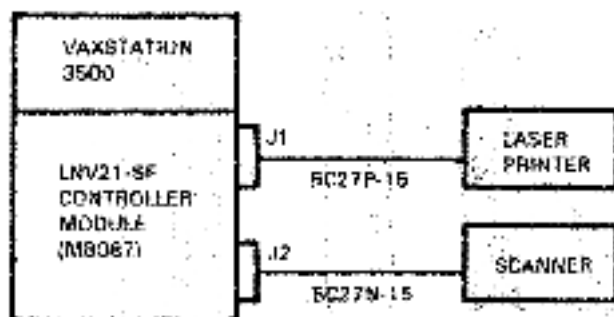

CS-7045

Figure 1-2. M8087 Module, Cables, Laser Printer and Scanner

1.2.2 Gap Fillers (P/N 70-24505-01)

The two gap fillers (see Figure 1-3) are used to comply with FCC regulations, when installing a module with either a blank cover or flushed handle next to a module with a recessed handle. These gap fillers provide for continuity in the ground connections.

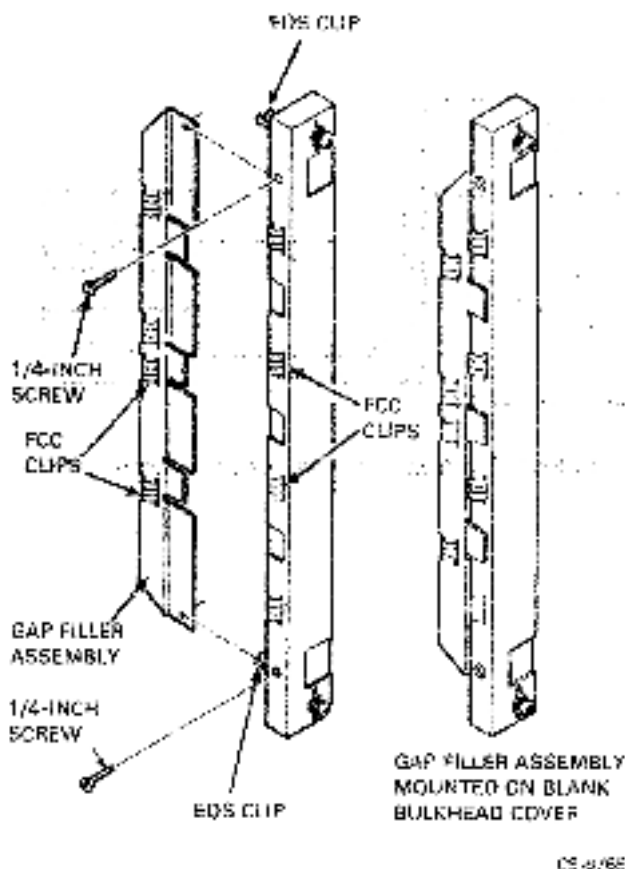

Figure 1-3 Gap Fillers

1.2.3 Loopback Cable (P/N 17-02250-01)

The loopback cable (see Figure 1-4) is for diagnostic purposes only. This cable incorporates two Champ connectors and a very short cable. This cable connects to J1 and J2 of the M8087 module.

CAUTION

The loopback cable is to be used by DIGITAL Field Service or qualified customer maintenance personnel only.

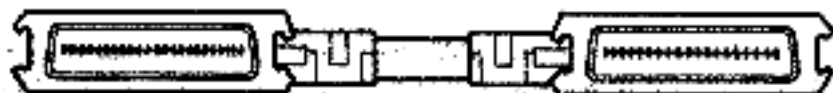

CS-7014

Figure 1-4 Loopback Cable

1.3 BA213 MICRO SYSTEM ENCLOSURE

The VAXstation workstation systems use the Q22-bus for I/O operations. This bus is the common communications path between the Central Processor Unit (CPU), memory, and device interfaces installed as Q22-bus modules.

VAXstation workstation systems are packaged in the BA213 system enclosure. The BA213 enclosure (see Figure 1-5) includes the following subassemblies:

- Two 230 W power supplies
- 12-slot backplane
- Space for four 13.33 cm (5.25 in) mass storage devices
- Front control panel and assembly

The BA213 backplane incorporates Q22-bus wiring in rows A and B of connector slots 1 through 12. Rows C and D of all slots are interconnected. The Q22-bus supports an interrupt and DMA grant-continuity scheme for the logic modules installed in the backplane. This backplane supports a maximum of 36 ac loads and 20 dc loads.

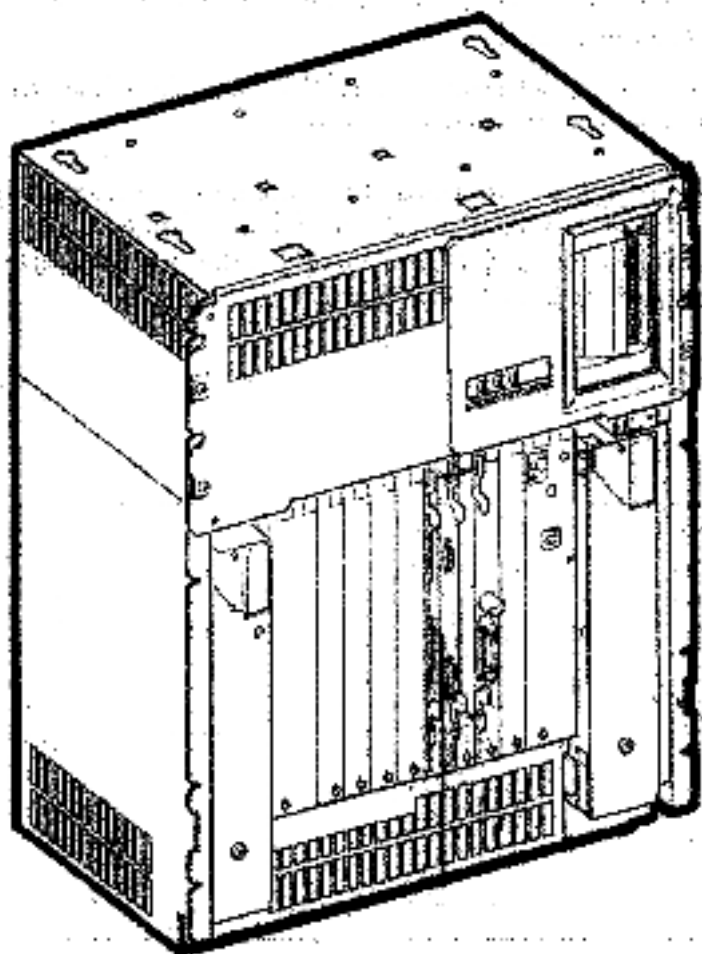

CS-7046

Figure 1-5 BA213 Enclosure

There are two main differences between the modules used in the BA213 enclosure and the modules used in other VAXstation system enclosures:

1. Option modules that connect to external devices have handles. These handles replace the insert panels and internal cabling found in BA23 and BA123 enclosures.
2. Modules that do not have external I/O connections (such as memory modules) have blank bulkhead covers.

Each handle and cover has two quarter-turn fasteners to secure the module to the card cage. Module handles also have release levers to help install or remove the module from the card cage. Figure 1-6 shows the four basic types of handles and covers used for BA213-style modules.



SINGLE-WIDTH
FLUSH HANDLE

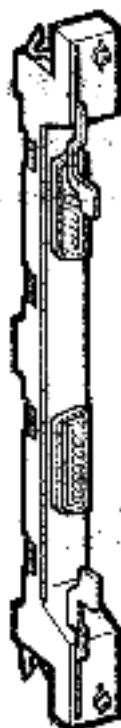

SINGLE-WIDTH
RECESSED HANDLE



SINGLE-WIDTH
BLANK HANDLE



DUAL-WIDTH
BLANK HANDLE

CR-6451

Figure 1-6 BA213 Handles and Covers

When a flush-handle module is installed next to a recessed-handled module, a metal gap filler must be installed between the modules to meet FCC regulations. Without the gap filler, circuitry on the recessed-handle module will be exposed.

1.4 LNV21-SF CONTROLLER SPECIFICATIONS

Table 1-2 summarizes the LNV21-SF Controller specifications.

Table 1-2 LNV21-SF Controller Specifications

Item	Specification	Remarks
Physical Specifications:		
Height	25.72 cm (10.125 in.)	Quad-Height
Width	2.06 cm (0.812 in.)	Single Width
Length	30.89 cm (12.125 in.)	Bottom of fingers to the top of handle
Weight	236.84 gm (26 oz.)	Approximate weight
Electrical Specifications:		
Power requirements	+5.0 V	± 5%, 2.8 A typical
DC Loading	0.5 dc loads to the bus	
AC Loading	4 ac loads to the bus	
Environmental Specifications:		
Storage Temperature	-40°C to 66°C (-40°F to 150.8°F)	

Table 1-2 LNV21-SF Controller Specifications (Cont)

Item	Specification	Remarks
CAUTION		
<p>Before operating a module at a temperature beyond the operating range, the module must first be brought to an environment within the operating range and then the module must be allowed to stabilize for a reasonable amount of time.</p>		
Operating Temperature	5°C to 60°C (41°F to 140°F)	See Caution Above
Operating Airflow		See Caution Below
CAUTION		
<p>Adequate airflow must be provided to limit the inlet-to-outlet temperature rise across the module, so that the outlet temperatures never exceed 70°C (158°F). The typical power dissipation of the module is such that with a 30°C (140°F) inlet temperature, adequate airflow can be achieved with a 1.2 m/second linear airflow. No area of the module may be subjected to a local ambient temperature above 70°C (158°F) under any environmental conditions.</p>		
Relative Humidity		
Storage	10% to 95%	Non-condensing
Operating	10% to 95%	Non-condensing
Altitude		
Storage	9.1 Km (30,000 ft.)	Approximately
Operating	2.4 Km (8,000 ft.)	Approximately

... ..
... ..
... ..

... ..
... ..
... ..

... ..
... ..
... ..

... ..
... ..

... ..
... ..
... ..

... ..
... ..
... ..
... ..
... ..
... ..

... ..
... ..
... ..

... ..
... ..
... ..

... ..

CHAPTER 2 INSTALLATION

2.1 INTRODUCTION

This chapter provides step-by-step procedures for unpacking the LNV21-SF Controller (M8087 module). It provides information on system and M8087 module configurations, relocating existing modules, installing the LNV21-SF Controller, and connecting external devices.

CAUTION

Only qualified service personnel should remove or install modules.

2.2 UNPACKING THE MODULE

Perform the following steps to unpack and inspect the contents of the LNV21-SF Controller shipping container.

1. Check the shipping container for external damage such as dents, holes, or crushed corners.
2. Put on the antistatic wrist strap.

CAUTION

Attach the antistatic wrist strap and the antistatic mat to the metal chassis of the BA213 enclosure. Stand on the antistatic mat when installing the module in the backplane.

3. Check the contents of the shipping container in accordance with the following list and Figure 2-1. Identify and list any missing items, and notify the sales representative and the delivery agent immediately.
 - LNV21-SF Controller (M8087 Module)
 - Loopback Cable (P/N 17-02250-01)
 - Gap Fillers (P/N 70-24505-01)
 - *LNV21-SF Controller Installation/Owner's Manual (EK-V21SF-1N)*
4. Remove the M8087 module from the antistatic bag.
5. Inspect all pieces of the LNV21-SF Controller option for signs of any shipping damage. If damage is found, stop unpacking immediately and notify the sales representative and delivery agent.

NOTE

Do not dispose of the packing material until the module has been successfully installed and is operational.

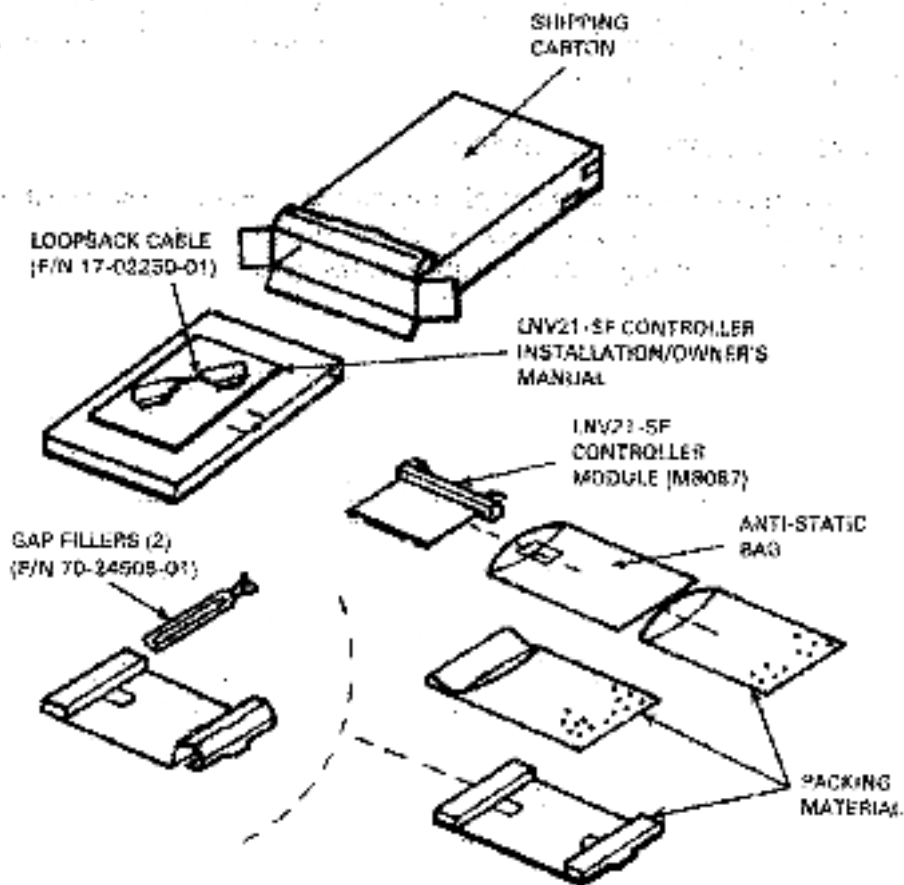

CS-7093

Figure 2-1 LNV21-SF Controller Option Shipping Contents

2.3 SYSTEM SOFTWARE

2.3.1 System Software Backup

It is the customer's responsibility to perform software backup. DIGITAL Field Service should ensure that the customer has taken this step before removing the front cover of the enclosure.

2.3.2 System Software Shutdown

It is the customer's responsibility to shut down the operating system software. DIGITAL Field Service personnel should ensure that the customer has taken this step before continuing with the testing of the system.

2.4 CONFIGURATION

The following sections contain information on configuring the VAXstation 3500 workstation and the M8087 module.

2.4.1 System Configuration

The M8087 module is designed to work in a VAXstation workstation model VS350 or VS355.

A block diagram of a VAXstation 3500 workstation system using the Q23-bus and the M8087 module to interface with the laser printer and scanner is shown in Figure 2-2. See Figures 2-3 and 2-4 to determine the correct placement of the M8087 modules in the backplane for the different configurations.

If the M8087 module is being installed in a system with a configuration other than those shown in Figures 2-3 and 2-4, complete the BA213 enclosure configuration worksheet (see Figure 2-5) to make sure that the system's power limits and bus loads have not been exceeded. Refer to the system documentation for complete system configuration rules and procedures.

The M8087 module must be placed just before the DELQA-SA interface module.

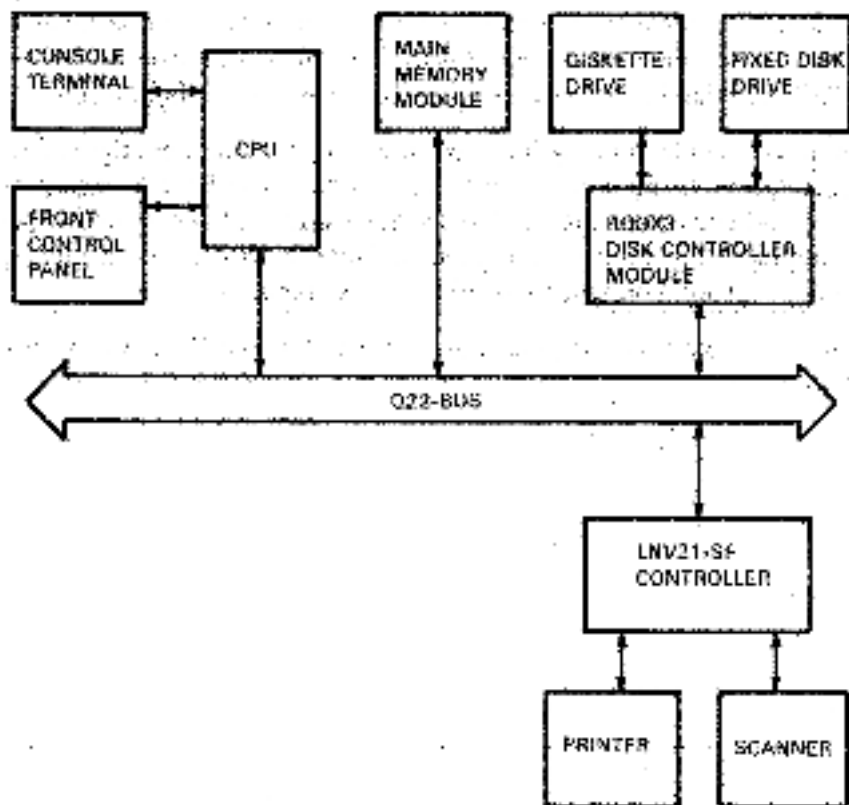

CS 7045

Figure 2-2 VAXstation 3500 System Q22-Bus

OPTION	UNIT	ADDR	VECT	A	B	C	D	COVER-PANEL	TYPE
KAB50-SA	1		1	-----	M7620-SA	-----		H3600-SA	F
MS650-AA	1		2	-----	M7621-AA	-----		H3600-SA	F
MS650-AA	2		3	-----	M7621-AA	-----		70-23981-01	F
LN/V21-SF	1	760620	300	-----	M92E7	-----		LN/V21 HANDLE	H
DELCA-SA	1	774440	120	-----	M7519	-----		DELCA HANDLE	F
VCB02-H	1	777400	320	-----	M7169	-----		70-23982-06	F
			7	-----	M7166	-----		70-23982-06	F
TQK70-SA	1	774500	260	-----	M7569	-----		70-23981-01	F
KDAB0-SA	1	772150	154	-----	M7164	-----		70-23981-01	F
			10	-----	M7165	-----		70-23982-02	F
			11	-----		-----		70-23982-02	F
			12	-----		-----		70-23982-02	F

45-7082

Figure 2-3 Backplane Map for VAXstation Model VS350-AA

OPTION	UNIT	ADDR	VECT	A	B	C	D	COVER-PANEL	TYPE
KAB50-SA	1		1	V-----	M7620-SA	-----	<	H3600-SA	F
MS650-AA	1		2	V-----	M7621-AA	-----	<	H3600-SA	F
MS650-AA	2		3	V-----	M7621-AA	-----	<	70-23981-01	F
LN/V21-SF	1	760620	300	V-----	M90E7	-----	<	LN/V21 HANDLE	H
DELCA-SA	1	774440	120	V-----	M7519	-----	<	DELCA HANDLE	F
VCB02-H	1	777400	320	V-----	M7169	-----	<	70-23982-07	F
			7	V-----	M7166	-----	<	70-23982-07	F
			8	V-----	M7166	-----	<	70-23981-01	F
TQK70-SA	1	774500	260	V-----	M7569	-----	<	70-23981-01	F
KDAB0-SA	1	772150	154	V-----	M7164	-----	<	70-23982-02	F
			11	V-----	M7165	-----	<	70-23982-02	F
			12	V-----		-----	<	70-23982-07	F

45-7081

Figure 2-4 Backplane Map for VAXstation Model VS355-AA

12-SLOT ENCLOSURE

RIGHT-HALF POWER SUPPLY					BUS LOADS	
SLOT (ABCD)	MODULE	CURRENT (A)	AMPS (12 V)	POWER (WATTS)	AC	DC
1						
2						
3						
4						
5						
6						
7						
8						
MASS STORAGE >>> TAPES					0.0	0.0
>>> DISK					0.0	0.0
TOTAL RIGHT-HALF POWER SUPPLY					—	—
MUST NOT EXCEED		33.0	7.0	730.0	—	—
LEFT-HALF POWER SUPPLY						
SLOT (ABCD)	MODULE	CURRENT (A)	AMPS (12 V)	POWER (WATTS)		
9						
10						
11						
12						
MASS STORAGE DISK					0.0	0.0
DISK					0.0	0.0
DISK					0.0	0.0
TOTAL LEFT-HALF POWER SUPPLY						
MUST NOT EXCEED		33.0	7.0	230.0 *		
TOTAL BUS LOADS						
MUST NOT EXCEED					36.0	30.0

CS-7140

Figure 2-5 BA213 Enclosure Configuration Worksheet

2.4.2 Configuring the M8087 Module

CAUTION

Attach the antistatic wrist strap and the antistatic mat to the metal chassis of the BA213 enclosure. Stand on the antistatic mat when installing the module in the backplane.

Before installing the M8087 module in the Q22-bus backplane, verify that the factory installed jumpers are installed correctly. The M8087 module contains three banks of eight factory preset jumpers. These include:

- Frame Registration
- Line Registration
- Configuration Jumpers

There are also seven user-selectable jumpers. These user-selectable jumpers include:

- 9-bit Device Address
- DMA Transfer Mode
- Holdoff Timer
- Scanner Line Sync
- Signal Ground (Printer)
- Signal Ground (Scanner)
- 8-bit Software Jumpers

Table 2-1 lists the factory preset jumpers, and Table 2-2 lists the user selectable jumpers on the M8087 module.

The M8087 module and the various locations of jumpers is shown in Figure 2-6.

Table 2-1 M8087 Module Factory Preset Jumpers

Jumpers Designation	Function
W2, W6 - W11	Configuration Jumpers
W20 - W37	Frame Registration
W38 - W45	Line Registration

Table 2-2 M8087 Module User Selectable Jumpers

Jumpers Number	Description	Condition
W1	DMA Transfer Mode	Out
W8	Holdoff Timer	Out
W12	Scanner Line Sync	In (Pins 1 and 2)
W13 - W21	Device Address	(As shown on following pages)
W22 - W29	Software Jumpers	(As shown on following pages)
W46	Signal Ground (Scanner)	Out
W47	Signal Ground (Printer)	Out

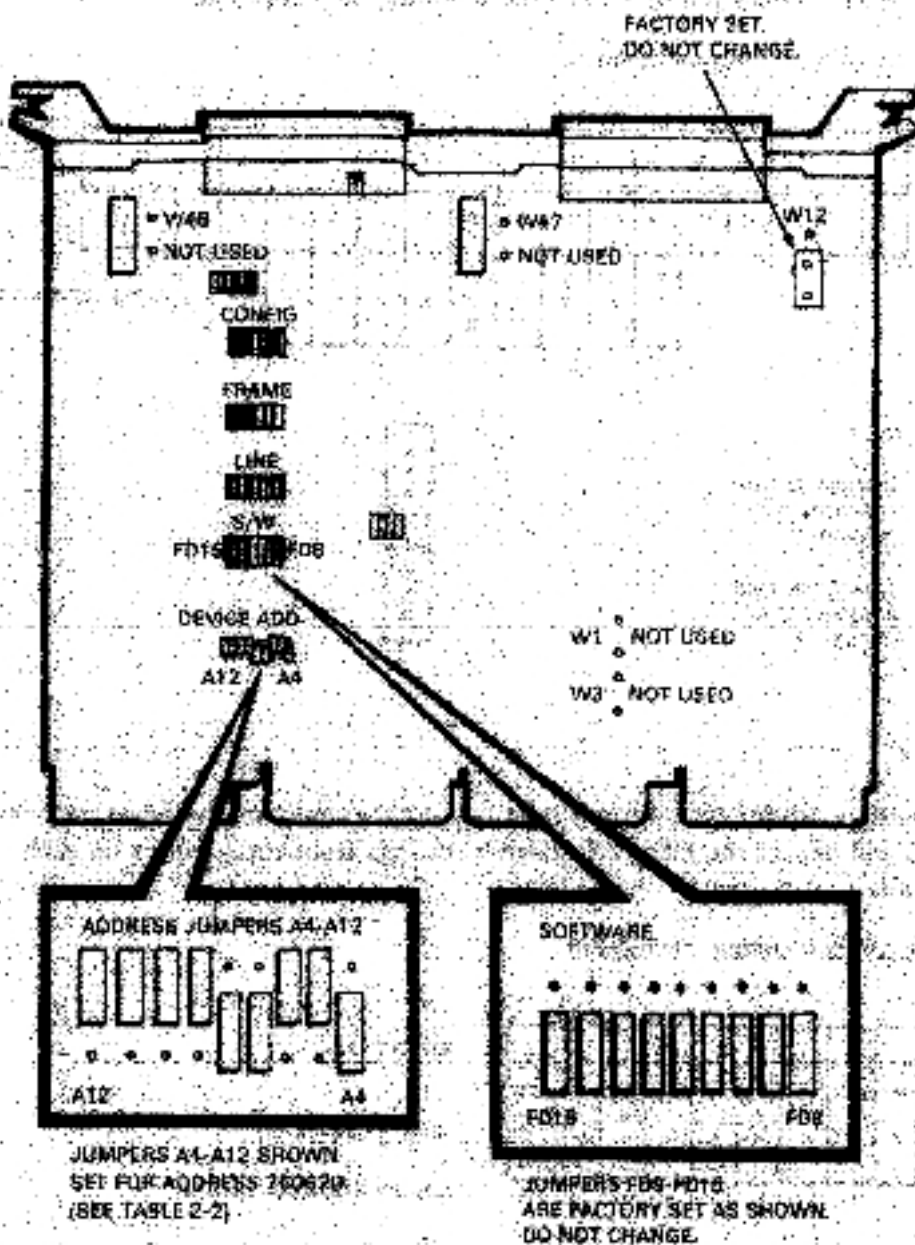

Figure 2-5 M3087 Module and Jumpers Locations

The device address jumpers have the following configuration.

CSR to LNV21 Jumper Relation



NOTE

JUMPER IN THIS POSITION IS A LOGIC 0

JUMPER IN THIS POSITION IS A LOGIC 1



CS-7124

If multiple M8087 modules are used in a system (maximum of two modules), VMS will expect the following address settings from the jumpers on each module.

First M8087 module at 760620



BIT SETTINGS

JUMPER SETTINGS

BINARY REPRESENTATION

CS-7640

12	11	10	9	8	7	6	5	4
X	X	X	X			X		X
X	X	X	X	X	X	X	X	X
				X	X		X	
0	0	0	0	1	1	0	1	0

BIT SETTINGS

0

JUMPER SETTINGS

1

BINARY REPRESENTATION

06-7024

The frame registration jumpers and the line registration jumpers are factory set for the scanner. These settings are shown below.

Frame registration jumpers

MSB

F	F	F	F	F	F	F	F
D	D	D	0	D	0	0	0
7	6	5	4	3	2	1	0

ALL 0 OHM RESISTORS SHOULD BE INSTALLED AS SHOWN (8 TOTAL)

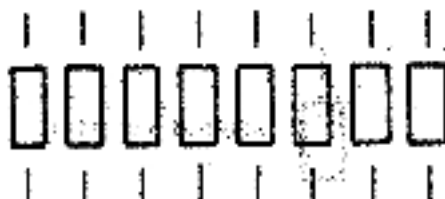

ADDRESS = 00000000

09-7080

Registration jumpers

MSB

P	F	F	F	F	F	F	F
C	D	D	D	D	D	D	D
7	6	5	4	3	2	1	0

ALL 0 OHM RESISTORS SHOULD
BE INSTALLED AS SHOWN
(5 TOTAL)



ADDRESS = 0000111

CS-7098

Configuration and software jumper locations are shown below.

Configuration jumpers

MSB

W	W	W	W	W	W	W	W
0	0	0	0	0	0	1	1
7	6	5	4	3	2	1	0

ALL 0 OHM RESISTORS SHOULD
BE INSTALLED AS SHOWN
(2 TOTAL)

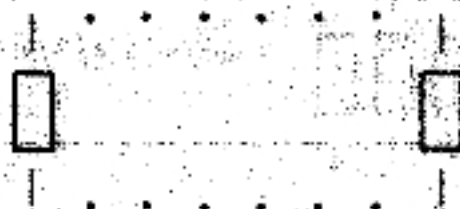

ADDRESS = 0111110

CS-7637

NOTE

This setting reflects the revision number of the module. The MSB indicates that the module is an MS007. The lower order bits give the numerical revision.

Software jumpers

F	F	F	F	F	F	F	F
D	0	0	0	0	0	0	0
1	1	1	1	1	1	0	0
5	4	3	2	1	0	0	0
X	X	X	X	X	X	X	X
X	X	X	X	X	X	X	X

BIT SETTINGS

JUMPER SETTINGS

2.5 TESTING THE EXISTING SYSTEM

Before installing the LNV21-SF Controller, test the existing system to verify that the system is operating properly by performing the following steps.

1. Install the diagnostic tape cartridge or diskette.
2. Run the MicroVAX Diagnostic Monitor (MDM) for VAXstation systems (refer to Chapter 3 for further information on testing and troubleshooting).

CAUTION

Always remove the tape cartridge from the tape drive unit before turning the I/O power switch off (0).

After a successful completion of the test, remove the tape cartridge or diskette, turn the I/O power switch off (0), and unplug the ac power cord from the wall outlet.

2.6 RELOCATING EXISTING MODULES

CAUTION

Only DIGITAL Field Service or qualified customer service personnel should remove or install modules.

If the M8087 module is to be installed in a slot that does not contain an existing module, proceed to Section 2.5.

If the M8087 module is to be installed in a slot that contains an existing module, use the following procedures to relocate existing modules.

2.6.1 Modules with Blank Covers

Use the following procedure to remove modules with blank covers.

CAUTION

Service personnel *must* use a grounded antistatic wrist strap and mat when removing or installing modules in a BA213 enclosure.

1. Release the two 1/4-turn captive screws that hold the blank cover to the card cage, using a Phillips screwdriver (see Figure 2-7).
2. Pull the blank cover away from the card cage.
3. Note the orientation of any internal cables connected to the module. Some connectors are not keyed. Carefully label and disconnect any internal cables.
4. Carefully pull the module out of the card cage.
5. Confirm the module's CSR address and interrupt vector; refer to the *MicroVAX System Maintenance Guide* (EK-001AA-MG) for help in determining the correct settings. Change jumpers or switch settings if necessary. If no change is necessary, be careful not to disturb any switchpacks on the module.
6. Reverse this procedure to install the module in a new location. Do not fasten the 1/4-turn captive screws until after the M8087 module is installed (refer to Section 2.7) and the ground connections have been verified (refer to Section 2.8).

8A218
ENCLOSURE

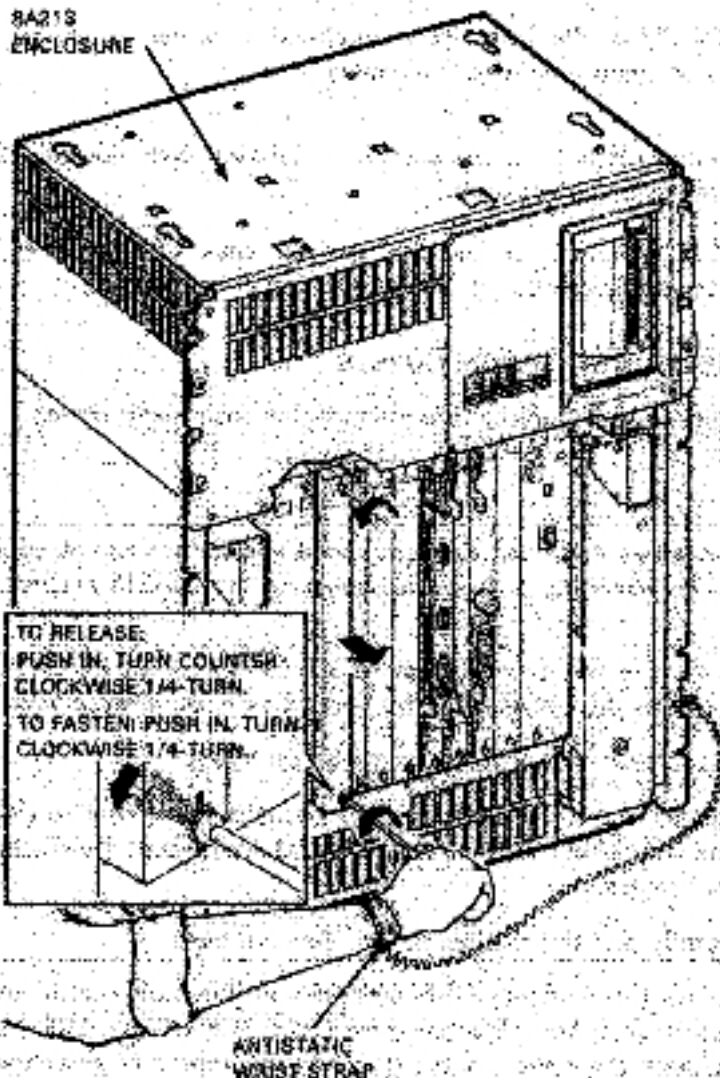

CS-1043

Figure 2-7 Releasing the Captive Screws

2.6.2 Modules with Handles

CAUTION

Only DIGITAL Field Service or qualified customer service personnel should remove or install modules.

CAUTION

Be sure to take antistatic precautions when removing or installing modules in a BA213 enclosure. Use the wrist strap and antistatic mat found in the Antistatic Kit (P/N 29-28240-00). (The Antistatic Kit is not included with this option kit. It is part of the Field Service Tool Kit.)

Use the following procedure to remove modules with handles:

1. Note the orientation of external cables connected to the module. Carefully label and disconnect the cables.
2. Release the two 1/4-turn captive screws that hold the module's handle to the card cage (see Figure 2-7).
3. Unlock the module release levers by simultaneously pulling up on the top lever and pushing down on the bottom lever (see Figure 2-8).
4. Pull out on the module's handle and carefully remove the module from the card cage.
5. Confirm the module's CSR address and interrupt vector. Refer to system documentation for help in determining the correct settings. Change jumpers or switch settings if necessary. If no change is necessary, be careful not to disturb any switchpacks or jumpers on the module.
6. Reverse this procedure to install the module in a new location. Do not fasten the 1/4-turn screws until the MS087 module has been installed (refer to Section 2-7) and the ground connections have been verified (refer to Section 2-8).

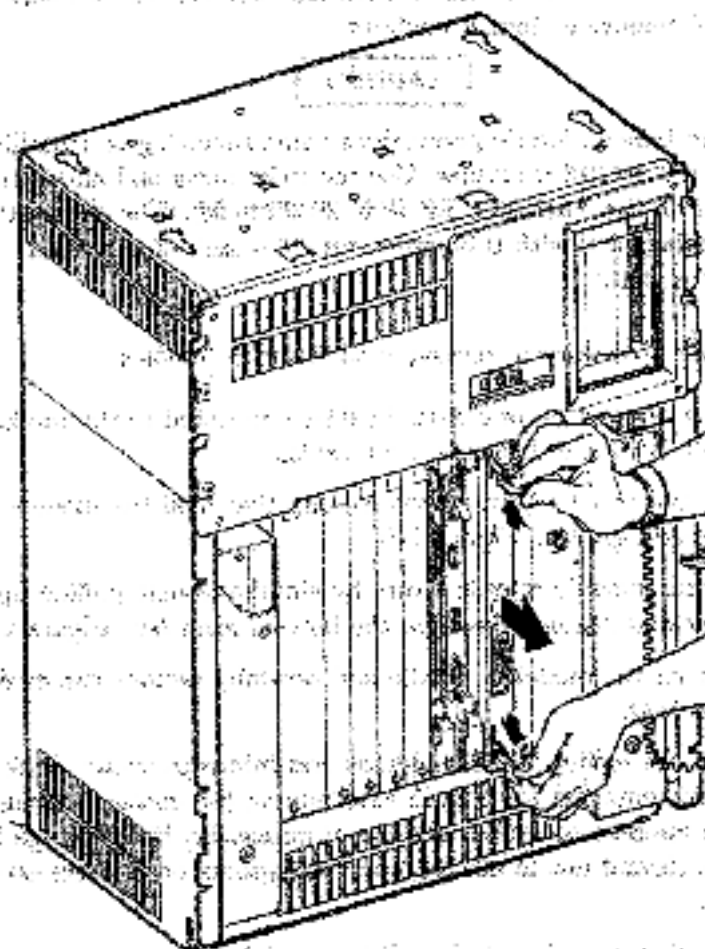

Figure 2-8 Unlocking the Release Levers

2.7 INSTALLING THE M8087 MODULE

NOTE

Refer to the documentation supplied with the VAXstation system for procedures on gaining access to the system card cage.

CAUTION

Be careful not to snag the module's components on the card guides or adjacent modules.

1. Install the M8087 module in the appropriate card slot (see Figures 2-3 or 2-4). Holding both the top and bottom release levers, lock the module in place by simultaneously pushing the top lever down and the bottom lever up (see Figure 2-9).
2. Do not fasten the 1/4-turn captive screws until the ground connections have been verified (refer to Section 2.8).

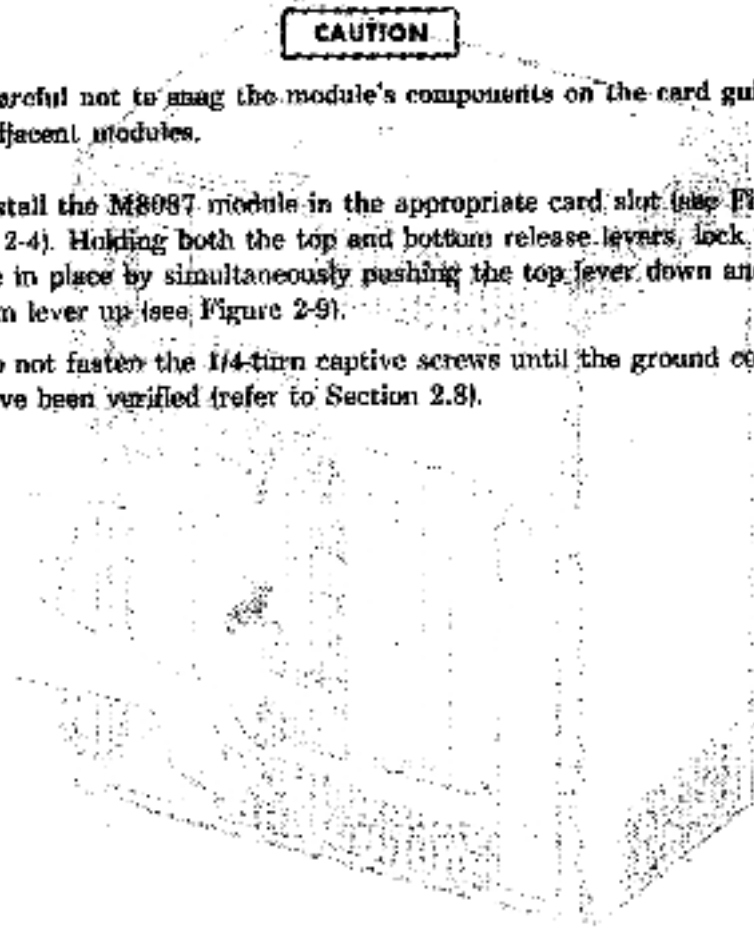

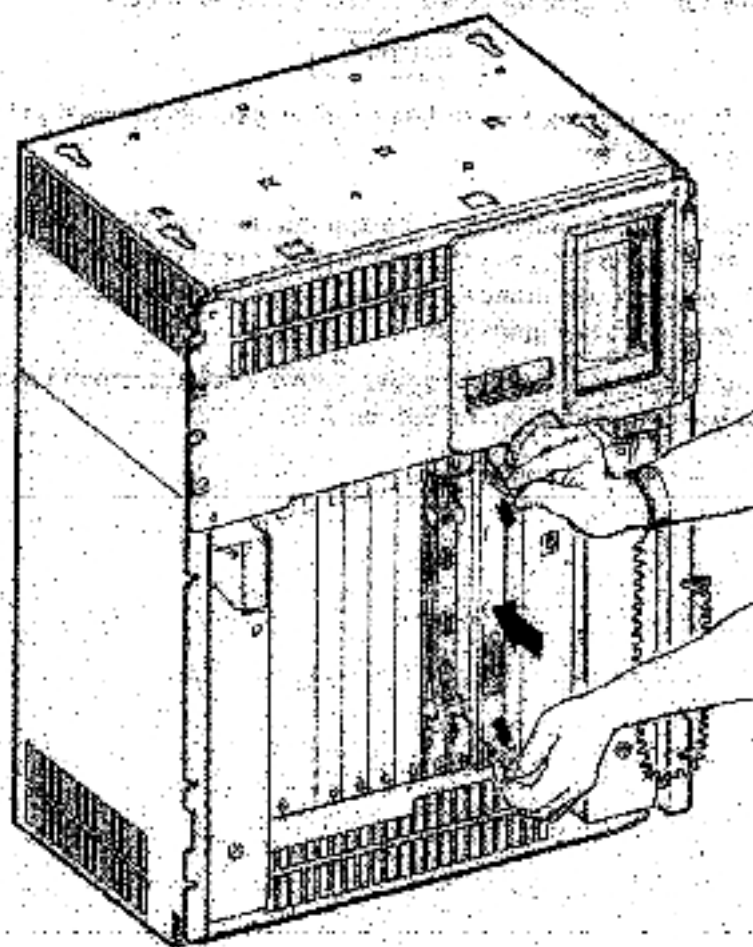

CS-9703

Figure 2-9 Inserting the M6887 Module

2.8 VERIFYING THE GROUND CONNECTIONS

When a module with either a blank cover or a flushed handle is installed next to a module with a recessed handle, it is necessary to install a gap filler assembly between the modules to meet FCC regulations. Without the gap filler, circuitry on the recessed-handle module is exposed.

Two gap filler assemblies (P/N 70-24605-01) are provided with the option kit. Each gap filler assembly includes one gap filler and two screws. It may be necessary to install one, both, or none of these assemblies.

Verify that the ground connections are correctly in place as follows:

1. Check to see if any recessed-handle module in the backplane has a module with a blank cover or a flush handle in the slot immediately before or after the recessed-handle module. If so, verify that a gap filler assembly is installed on the side of the blank cover or flush handle that is next to the recessed-handle module (see Figure 2-10). If no open spaces exist between the modules in the backplane, the filler kit is not needed.

NOTE

There should not be any open spaces between the modules in the backplane.

2. Fasten the 1/4-turn captive screws on all handles and covers in the backplane (see Figure 2-7).
3. If an open space exists between the modules in the backplane, install the gap filler assembly as follows:
 - Using two screws and one gap filler (P/N 70-24605-01), attach the gap filler to the top and bottom side of the blank cover or flush handle that fits next to the recessed-handle module. Ensure that the gap filler tabs fit into the tab indentations on the blank cover or flush handle (see Figure 3-11).
 - Place the blank cover with the gap filler over the card cage slot, or insert the flush handle module with the gap filler into the card slot.
 - Ensure that there is correct ground (no open spaces) between the two modules.
 - Fasten the 1/4-turn captive screws on all handles and covers in the backplane (see Figure 2-7).

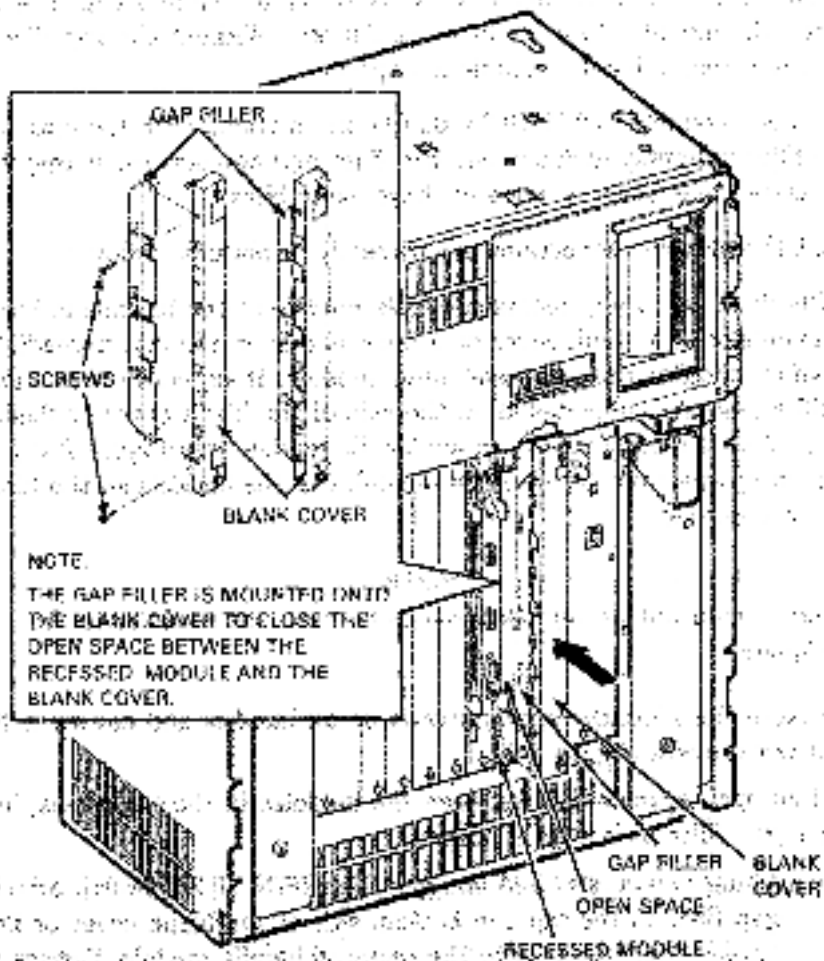

CS-6784

Figure 2-10 Ground Connections

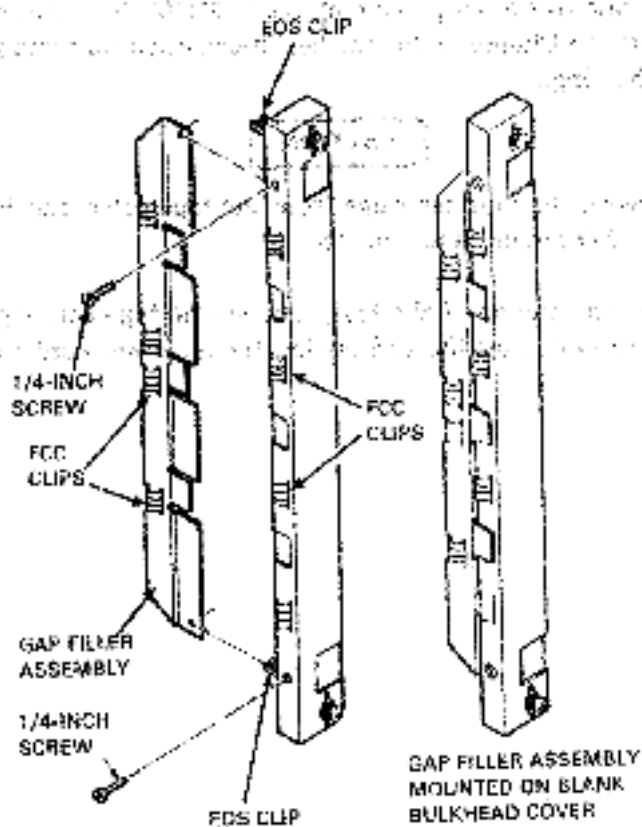

CS-6706

Figure 2-11 Attaching the Gap Filler Assembly

2.9 TESTING THE SYSTEM

To verify that the system is operating properly, perform the following steps:

1. Install the diagnostic tape cartridge or diskette.
2. Run the MicroVAX Diagnostic Monitor (MDM) for VAXstation systems (refer to Chapter 3 for further information on testing and troubleshooting).

CAUTION

Always remove the tape cartridge from the tape drive unit before turning the I/O power switch off (0).

After a successful completion of the test, remove the tape cartridge or diskette, turn the I/O power switch off (0), and unplug the ac power cord from the wall outlet.

2.10 CONNECTING EXTERNAL DEVICES

The following sections provide information on connecting the M8087 module to the laser printer and the scanner.

2.10.1 Laser Printer

The laser printer connects to the M8087 module through a 15-foot BC27P-15 cable to J1, the printer port, on the M8087 module. Figure 2-12 shows a typical external device cable, and Figure 2-13 shows the J1 printer connector on the M8087 module. The male D-subminiature end of the BC27P cable connects to the laser printer.

2.10.2 Scanner

The scanner connects to the M8087 module through a 15-foot BC27N-15 cable to J2, the scanner port, on the M8087 module. Figure 2-12 shows a typical external device cable, and Figure 2-13 shows the J2 scanner connector on the M8087 module. The female D-subminiature end of the BC27N cable connects to the scanner.

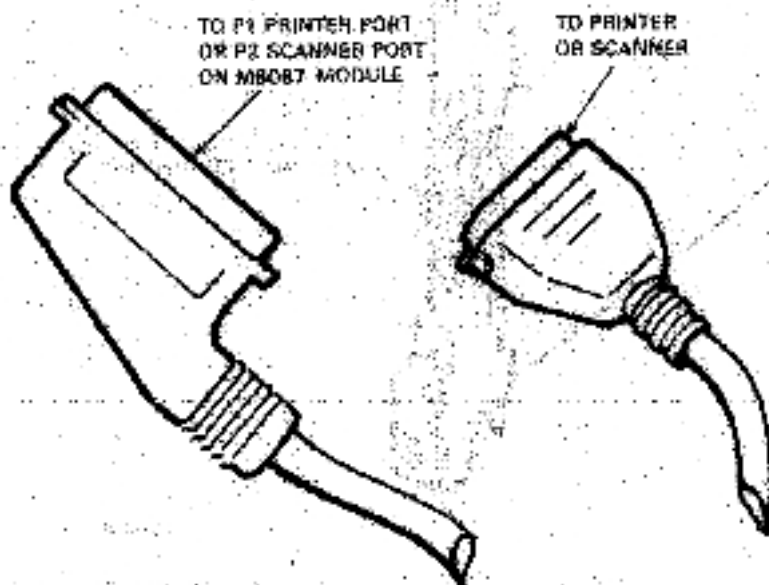

CS-1087

Figure 2-12 Typical External Device Cable

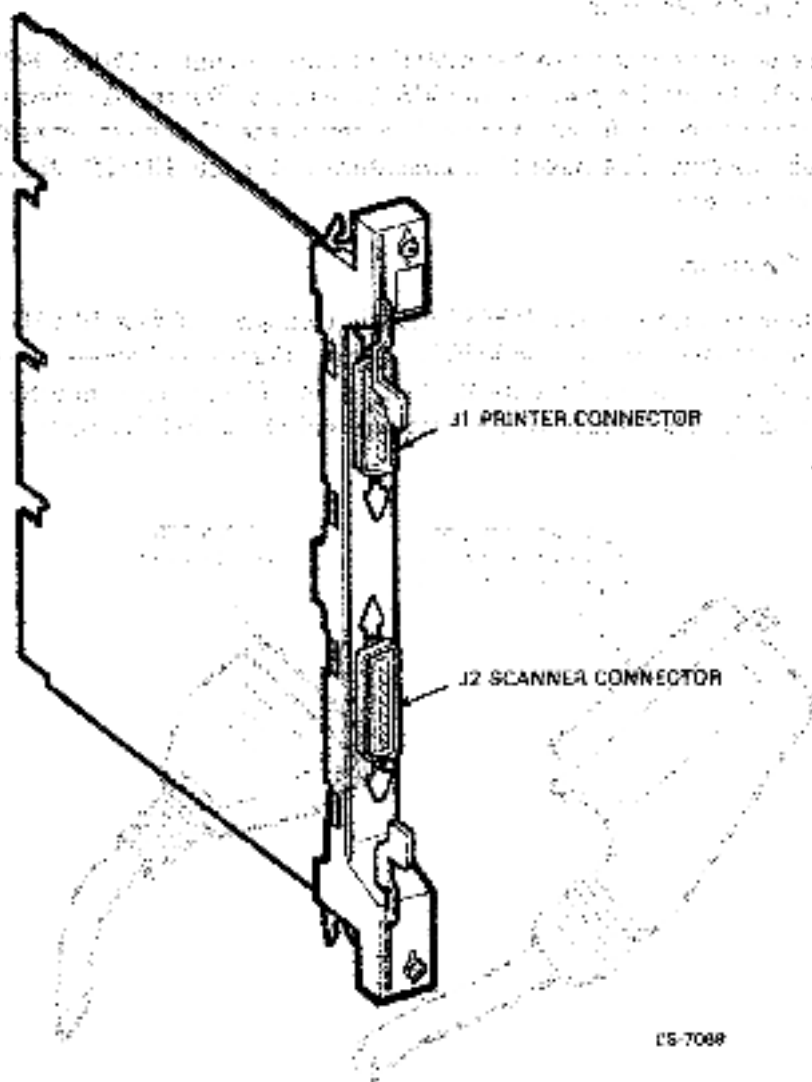

Figure 2-13 External Device Connectors on the M8087 Module

CHAPTER 3 MicroVAX DIAGNOSTICS MONITOR

3.1 INTRODUCTION

This chapter is a brief discussion of the MicroVAX Diagnostic Monitor (MDM). (Refer to the *MicroVAX Troubleshooting and Diagnostics Manual* (EK-O19AA-SG).)

The MDM is a software package containing diagnostic tests designed to isolate and identify faults in the system. The diagnostic tests are packaged with the system on either RX50 diskettes (labeled MV DIAG CUST RX50), or a tape cartridge (labeled MV DIAG CUST TK50). The LNV21-SF Controller is supported on MDM release 124 or greater.

CAUTION

If the system is connected to a cluster, notify the cluster manager before halting the system to load the MDM.

MDM is generally run to test the LNV21-SF Controller in three situations:

1. Testing the LNV21-SF Controller at installation time.
2. When an error message is received, or a problem is experienced with the system.
3. Testing the system periodically to ensure that all components are operating correctly.

MDM tests individual devices in the system; however, only limited diagnostics are performed:

- MDM does not check each device as thoroughly as the service diagnostic tests.
- MDM checks only devices and not the connections or lines between peripheral devices and the system.

3.2 RUNNING THE MDM

CAUTION

Before running the MDM software: 1) understand the instructions in your system-specific MicroVAX operations manual for using the appropriate device for the type of diagnostic media used (either the RX50 diskette drive or the TK50/TK70 tape drive); 2) understand the instructions in the *MicroVAX Troubleshooting and Diagnostics Manual* (EK-019AA-SG); 3) ensure that the media (tape cartridge or RX50 diskette) is write-protected.

3.2.1 MDM introductory Screen

When the MDM software is loaded, the MDM introductory screen is displayed. Ensure that the current date and time in the introductory screen are correct. If the date and time are correct, press the <RETURN> key to continue. If the date and time are incorrect, type the correct date and time using the format shown in the MDM introductory screen. For example, enter 25-DEC-1987 02:30 and press the <RETURN> key to continue. In a few moments a message will appear on the screen, stating that the system is preparing for testing.

NOTE

If the system is being booted from an RX50 diskette, the system will prompt the operator to insert additional diskettes. Follow the displayed instructions. When diagnostic loading is complete, a message will appear on the screen stating that the system is ready for testing.

Test preparation includes loading the remainder of the diagnostic software. The loading process takes several minutes. When loading is complete, a message will appear on the screen stating that the system is ready for testing.

At this time, press the <RETURN> key to obtain the Main Menu (refer to Section 3.2.2).

3.2.2 Main Menu Options

The Main Menu lists six options (shown below). Choose an option by typing the number of the desired option and pressing the <RETURN> key.

MAIN MENU

Release nnn Version xx.xx

- 1 - Test the System
- 2 - Display System Configuration and Devices
- 3 - Display the System Utilities Menu
- 4 - Display the Service Menu
- 5 - Display the Connect/Ignore Menu
- 6 - Select Single Device Tests

Type the number; then press the <RETURN> key.

NOTE

The MDM release and version numbers are represented by nnn and xx.xx in the sample screens provided throughout this chapter.

DIGITAL Field Service and qualified customer maintenance personnel should only select tests 1 and 6 for installation and testing.

To perform a full system test, select option 1 "Test the System". This will test all the options for which diagnostics have been installed. If only the LNV21-SF Controller is to be tested, select option 6 "Select Single Device Test".

The next two sections discuss tests 1 and 6.

3.2.2.1 Test the System — Test number 1, Test the System, runs a quick, general test of the devices in the system and how these devices work together. This test can be run at any time without jeopardizing data.

When "Test the System" is selected, a screen explaining the testing procedure appears.

When you are ready to begin the test, press the <RETURN> key. The "Begin Device Tests" screen appears. As each device passes the test, the device name is listed on the screen.

If a device fails a test, a failure message appears. Each failure message identifies the device being tested when the failure occurred, and the Field Replaceable Unit (FRU). Copy and report the failure message to a DIGITAL Field Service representative.

If the system has serious problems, the following message may appear:

All devices disabled, no tests run.

Report the message to a DIGITAL Field Service representative.

When a failure message occurs, testing stops.

When all devices pass the first part of the test, the exerciser test begins. This test takes about four minutes, and tests how the devices work together. At the end of the test, a success message is received.

At the end of the system test, press the <RETURN> key to return to the Main Menu. From the Main Menu, either exit the MDM by pressing the reset button, or pressing and releasing the Halt button. Option 6 can also be chosen by typing 6 and pressing the <RETURN> key.

3.2.2.2 Select Single Device Tests — Test number 8. Select Single Device Tests option, allows testing for a specific or single device. A general test of the device, performed during the single device test and called a "Functional Test" as well as an "Exerciser Test", ensures that the device is working properly with the other devices in the system.

When the Single Device Test is selected from the Main Menu, a screen listing the devices included in the system is displayed. The Main Menu of the Select Single Device Tests is shown below.

```
MAIN MENU                               Release non Test xx.xx
SELECT SINGLE DEVICE TEST
```

Select the device number to be tested. The functional tests will be run followed by the exercisers for four minutes.

- 1 - CPUA - MicroVAX/rtVAX CPU
- 2 - MEMA - MicroVAX II Memory System
- 3 - RQDXA - Winchester/diskette controller
- 4 - DEQNA - Ethernet controller
- 5 - DZQ11A - Asynchronous line controller
- 6 - LNV21A - Laser printer/scanner controller
- 7 - TKXXA - TK50/TK70 controller

Type the number, then press the <RETURN> key,
or type 0 and press the <RETURN> key to return to the Main Menu.

Select the LNV21 for testing by typing the number 6 and pressing the <RETURN> key.

Pressing the <RETURN> key starts the action for loading the diagnostics to the devices in the system, and testing begins. When the device passes the functional test, a message is displayed and the exerciser tests begin. The exerciser test runs for approximately four minutes. An example of a successful test is shown below.

```
BEGIN FUNCTIONAL TEST
DEVICE                               RESULT
LNV21A . . . . . PASSED

BEGIN EXERCISER TEST
RESULTS ARE REPORTED AT THE END OF THE TESTING
SINGLE DEVICE TEST PASSED
```

If a device fails a test, a failure message is displayed. Each failure message identifies the device being tested when the failure occurred, and the FRU. Copy the failure message and report the failure message to a DIGITAL Field Service representative. An example of an unsuccessful test is shown below.

BEGIN FUNCTIONAL TEST

Device	Result
--------	--------

LNV21A . . .	FAILURE DETECTED
--------------	------------------

A failure was detected while testing the

OPTION: LNV21A LASER PRINTER/SCANNER CONTROLLER

The Field Replaceable Unit (FRU) identified is the:

LNV21A

Press <RETURN> to return to the Single Device Menu for more testing. Type 0 and press <RETURN> to return to the Main Menu.

To exit MDM, press the Reset button, or press and release the Halt button.

Remove the RX50 diskette or TK50 tape cartridge per the instructions in your system-specific MicroVAX operation manual.

For additional information on exiting MDM and rebooting the system, refer to the *MicroVAX Troubleshooting and Diagnostics Manual* (EK-O19AA-SG).

The first part of the report deals with the general situation of the country and the progress of the work during the year. It is followed by a detailed account of the various projects and the results achieved. The report concludes with a summary of the work done and the plans for the future.

The first part of the report deals with the general situation of the country and the progress of the work during the year. It is followed by a detailed account of the various projects and the results achieved. The report concludes with a summary of the work done and the plans for the future.

The first part of the report deals with the general situation of the country and the progress of the work during the year. It is followed by a detailed account of the various projects and the results achieved. The report concludes with a summary of the work done and the plans for the future.

The first part of the report deals with the general situation of the country and the progress of the work during the year. It is followed by a detailed account of the various projects and the results achieved. The report concludes with a summary of the work done and the plans for the future.

The first part of the report deals with the general situation of the country and the progress of the work during the year. It is followed by a detailed account of the various projects and the results achieved. The report concludes with a summary of the work done and the plans for the future.

The first part of the report deals with the general situation of the country and the progress of the work during the year. It is followed by a detailed account of the various projects and the results achieved. The report concludes with a summary of the work done and the plans for the future.

The first part of the report deals with the general situation of the country and the progress of the work during the year. It is followed by a detailed account of the various projects and the results achieved. The report concludes with a summary of the work done and the plans for the future.

The first part of the report deals with the general situation of the country and the progress of the work during the year. It is followed by a detailed account of the various projects and the results achieved. The report concludes with a summary of the work done and the plans for the future.

The first part of the report deals with the general situation of the country and the progress of the work during the year. It is followed by a detailed account of the various projects and the results achieved. The report concludes with a summary of the work done and the plans for the future.

The first part of the report deals with the general situation of the country and the progress of the work during the year. It is followed by a detailed account of the various projects and the results achieved. The report concludes with a summary of the work done and the plans for the future.