

Installing and Using The DECimage 1200 Video Terminal

Order Number EK-V120I-IN-001

Digital Equipment Corporation

First Edition, February 1991

The information in this document is subject to change without notice and should not be construed as a commitment by Digital Equipment Corporation. Digital Equipment Corporation assumes no responsibility for any errors that may appear in this document.

The software described in this document is furnished under a license and may be used or copied only in accordance with the terms of such license.

No responsibility is assumed for the use or reliability of software on equipment that is not supplied by Digital Equipment Corporation or its affiliated companies.

Restricted Rights: Use, duplication, or disclosure by the U. S. Government is subject to restrictions as set forth in subparagraph (c) (1) (ii) of the Rights in Technical Data and Computer Software clause at DFARS 252.227-7013.

Copyright © by Digital Equipment Corporation 1991

All Rights Reserved.
Printed in Taiwan.

FCC NOTICE: The equipment described in this manual generates, uses, and may emit radio frequency energy. The equipment has been type tested and found to comply with the limits for a Class A computing device pursuant to Subpart J of Part 15 of FCC Rules, which are designed to provide reasonable protection against such radio frequency interference when operated in a commercial environment. Operation of this equipment in a residential area may cause interference, in which case the user at his own expense may be required to take measures to correct the interference.

The following are trademarks of Digital Equipment Corporation: DECimage, DECwindows, LAT, PDP, ThinWire, ULTRIX, VMS, VT, VT1000, VT1200, and the DIGITAL logo.

UNIX is a registered trademark of UNIX System Laboratories.

This document was prepared and published by Educational Services Development and Publishing, Digital Equipment Corporation.

Contents

- About This Guide** v

- 1 A Look at Your Video Terminal**
- Imaging and the DECimage 1200 Terminal 2
- XIE Software on the DECimage 1200 Terminal 2
- Differences Between the DECimage 1200 and VT1200 Terminals 2

- 2 Installing Your Video Terminal**
- Site Preparation 3
- Unpacking 6
- Installation 7
- Verifying the Memory Installation 10

- 3 Installing Optional Memory**
- Installation 11

- 4 Upgrading to a DECimage 1200 Terminal**
- Unpacking 16
- Installation 18
- Verifying the Memory Installation 22

5	Improving Hard-to-Read Images	
	How Does the Terminal Display an Image?	23
	How Can You Improve an Image?	24
	Displaying the Customize Image Dialog Box	25
	Customizing the Image	27
6	Solving Problems	
A	Specifications	
	Site Planning	32
	Display	32
B	Options and Documentation	
	Related Documentation	33
C	X Window Image Extensions	
	The XIE Subset	34
	Pipelines	34
	Decompression Constraints	35
	Scaling Constraints of the XIE Server	35
	XCopyArea and XCopyPlane Constraint	35
	XIE Functions	36
	Tables	
	C-1 XIE Functions in the DECimage 1200 Terminal	36

About This Guide

This guide describes how to:

- Install your DECimage 1200 video display terminal.
- Upgrade your VT1000 terminal or VT1200 terminal to a DECimage 1200 terminal.

The guide is a supplement to:

Installing and Using the VT1200 Video Terminal

Who Should Use This Guide

This guide is for the installer and general user of the DECimage 1200 video terminal.

Organization

This guide contains the following chapters and appendices:

- Chapter 1, “A Look at Your Video Terminal,” provides an overview of the DECimage 1200 terminal and lists the differences between the DECimage 1200 terminal and the VT1200 terminal.
- Chapter 2, “Installing Your Video Terminal,” describes how to install your terminal.
- Chapter 3, “Installing Optional Memory,” describes how to install additional memory.
- Chapter 4, “Upgrading to a DECimage 1200 Terminal,” describes how to upgrade a VT1000 or VT1200 terminal to a DECimage 1200 terminal.
- Chapter 5, “Improving Hard-to-Read Images,” describes how to use the Customize Image dialog box to improve images that are hard to read on the screen.

- Chapter 6, “Solving Problems,” describes how to solve operating problems, including basic X window image extension (XIE) protocol problems.
- Appendix A, “Specifications,” lists DECimage 1200 specifications.
- Appendix B, “Options and Documentation,” lists options, related documentation, and ordering information.
- Appendix C, “X Window Image Extensions,” describes the DECimage 1200 implementation of the XIE protocol.

Conventions

The following conventions are used in this guide:

<code>IO</code>	Keys or switches that are labeled appear in a <code>box</code> . Example: Press the <code>Return</code> key.
<code>Ctrl</code> <code>key</code>	For <code>Ctrl</code> key sequences, hold down <code>Ctrl</code> and press the other key.
Warnings	Provide information to prevent personal injury.
Cautions	Provide information to prevent damage to equipment or software.
Notes	Provide general information about the current topic.

1

A Look at Your Video Terminal

This chapter introduces you to the DECimage 1200 video display terminal. Refer to *Installing and Using the VT1200 Video Terminal* for a complete description of the DECimage 1200 terminal, except for the differences described in this guide.

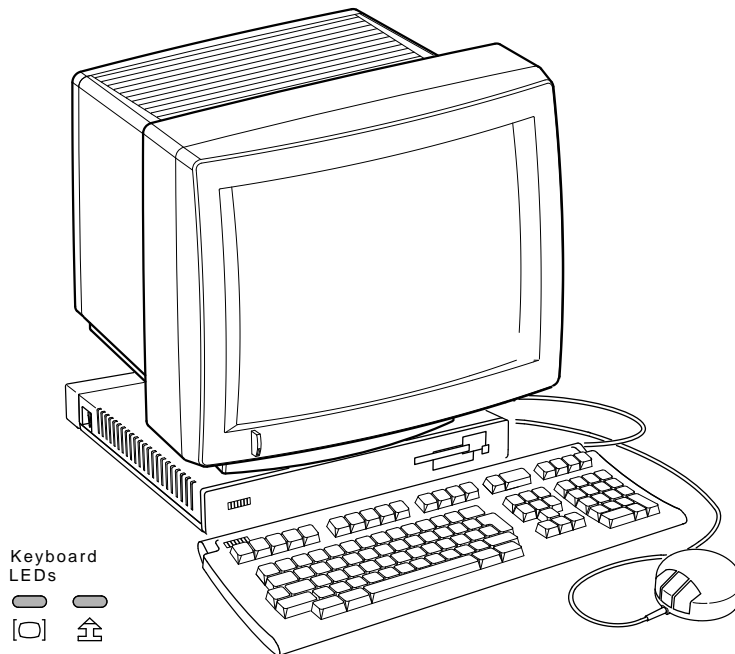

MA-0248-90.DG

Imaging and the DECimage 1200 Terminal

The DECimage 1200 terminal lets you run X window applications on your computer system, including Digital's DECwindows software and X window image extensions (XIE) software. The imaging features allow the terminal to send compressed image files to the server and to display image information faster.

From the DECimage 1200 Terminal Manager window, you can display a Customize Image dialog box with features to improve images that are hard to read on the screen (Chapter 5).

XIE Software on the DECimage 1200 Terminal

The DECimage 1200 terminal has an XIE server that lets the terminal run XIE applications. XIE applications let the terminal display images quickly by decompressing, scaling, and rotating data. See Appendix C for a description of XIE routines, their functions, and restrictions.

Differences Between the DECimage 1200 and VT1200 Terminals

There are only two physical components that make the DECimage 1200 terminal different from the VT1200 terminal.

The DECimage 1200 uses ...

an image board with connectors for optional memory.
a ROM board with imaging software.

While the VT1200 uses ...

a RAM board with connectors for optional memory.
a ROM board without imaging software.

2

Installing Your Video Terminal

This chapter explains how to install a new DECimage 1200 terminal. The chapter provides step-by-step instructions on how to:

- Prepare for installation.
- Unpack, inspect, and check the terminal's components.
- Connect your terminal's monitor, mouse, and keyboard.
- Connect a printer, modem, or tablet to the terminal.
- Connect your terminal to a network.
- Turn on your terminal.

NOTE

If you are upgrading your terminal to a DECimage 1200 terminal, go to Chapter 4.

Site Preparation

Before you install your DECimage 1200 terminal, make sure your computer system has the necessary network hardware and system software to support the terminal. See your system manager to ensure these requirements are met.

For System Managers

System managers need to prepare the computer system for use with the terminal. Refer to the "System Management Tasks" appendix in the *Installing and Using the VT1200 Video Terminal* guide for a description of the required tasks.

4 Installing Your Video Terminal

Network Hardware Support

The DECimage 1200 terminal requires one of the following physical connections to connect to a host computer system:

ThinWire connector Lets the terminal operate with X window applications and multiple text terminal sessions, using either the LAT or TCP/IP network protocol. You must use the ThinWire connector to operate with X window or DECwindows software.

Serial line Lets the terminal connect to a single host or terminal server as a traditional text terminal.

System Software Support

The following table summarizes the system resources needed to open X window sessions or video terminal (VTE) sessions:

Operation	Operating System	Communication Protocol
Video terminal session	VMS Version 4.0 or higher	LAT
	UNIX (any Berkeley (BSD) compliant version)	TELNET (TCP/IP)
	ULTRIX (any version)	TELNET (TCP/IP)
X window session	VMS Version 5.3-1 or higher	LAT
	UNIX (any version)	TELNET (TCP/IP)
	UWS Version 2.2 (includes ULTRIX Version 3.1) or higher	TELNET (TCP/IP)

Selecting a Location

Use the following guidelines to select a good location for your terminal:

- Select a surface area that is large enough to hold your system box, monitor, keyboard, and mouse.
- Place your monitor so that the top line of the monitor display is at eye level.
- To avoid screen glare, select a place where bright light will not reflect off the monitor.
- Do not block the air vents on the sides of the system box or place the system box on its side. Blocking the air vents can cause the system to overheat.
- Keep the area clean. Do not place food or liquid on or near your terminal.
- Keep the temperature between 10° and 40° C (50° and 104° F), and the relative humidity between 10% and 95%.
- Keep the air well circulated, to prevent excess heat and dust from accumulating.
- Keep your terminal away from heaters, photocopiers, direct sunlight, and abrasive particles.

Unpacking

Unpack and check the contents of each carton.

Make sure you have all the items shown in the following figure. Carefully inspect the components for shipping damage. If you have any missing or damaged items, contact your sales representative and delivery agent.

WARNING

If necessary, use two people to lift or move the monitor out of the shipping carton. Approximate monitor weights:

- **VR315 monitor (380 mm/15 inch): 13 kg (29 lb)**
- **VR319 monitor (480 mm/19 inch): 27 kg (60 lb)**
- **VRE01 monitor (480 mm/19 inch): 7 kg (15 lb)**

DECimage 1200 Parts Checklist

- ① Monitor: VR319 (shown), VR315, or VRE01
- ② Power cord for the monitor
- ③ Monitor installation guide
- ④ System box
- ⑤ Power cord for the system box
- ⑥ Mouse
- ⑦ DEC-423 communication cable with EIA adapter (6-pin to 25-pin) attached
- ⑧ Monitor cable
- ⑨ Keyboard and legend strip
- ⑩ Ethernet cable and connector
- ⑪ *Installing and Using the DECimage 1200 Video Terminal*
- ⑫ *Installing and Using the VT1200 Video Terminal*
- ⑬ Rear dress panel

Optional

- ⑭ SIMM memory card(s)

NOTE

If you receive three power cords (a short one and two long ones), the second long power cord is not needed for this installation.

Installing Your Video Terminal 7

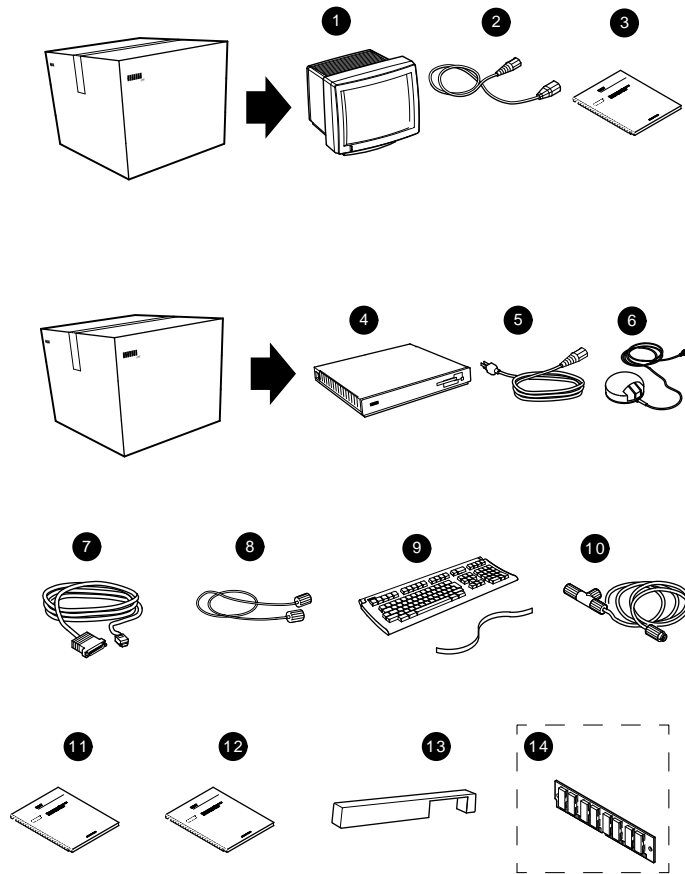

MA-0249-90.DG

Installation

Install any optional memory first.

If you ordered optional memory for your terminal, go to Chapter 3. You should install the memory cards in the system box before proceeding.

8 Installing Your Video Terminal

Connect the cables to the system box.

Perform the following steps to connect cables and set the monitor selection switch on the rear of the system box. The steps are keyed to the figure.

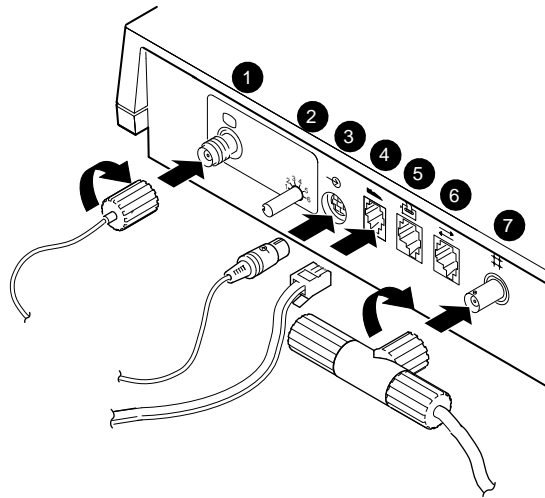

MA-0667-90.DG

Step	Action
①	Connect one end of the monitor cable to the monitor and the other end to the system box. If you have a VRE01 monitor, attach the cable-holding fixture to the rear of the monitor before connecting the cable.
②	Set the monitor selection switch to match your monitor. VR319 = 2 VR315 = 5 VRE01 = 3
③	Connect the mouse or graphics tablet to the system box.
④	Connect the keyboard to the system box.
⑤	Serial printer port: If you have a printer or secondary host computer, connect the printer or host to the system box.
⑥	Serial host port: If you have a primary host computer or terminal server, connect the host or server to the system box.
⑦	Connect the ThinWire Ethernet connector to the system box. Connect the other end to your local area network.

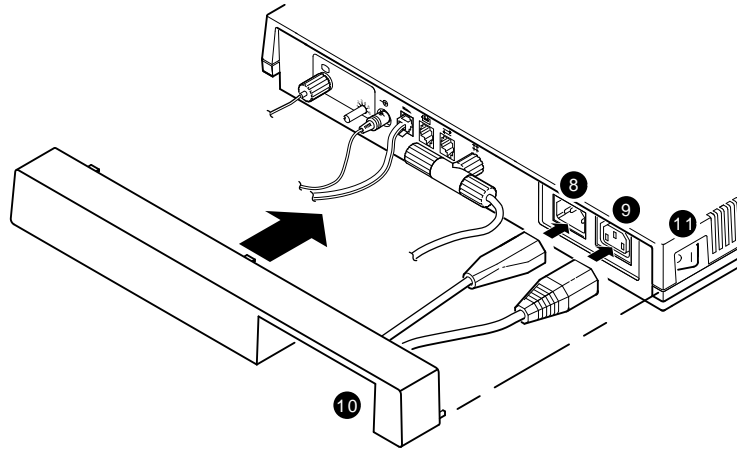

MA-0668-90.DG

Step	Action
8	Make sure the <input type="checkbox"/> power switches on the monitor and system box are off (O). Then connect the long power cord from the system box to the wall outlet.
9	Connect the short power cord from the monitor to the system box.
10	Route all cables under the dress panel. Push the dress panel onto the system box.
11	Turn the monitor's <input type="checkbox"/> power switch on by pressing (I). Turn the system box's <input type="checkbox"/> power switch on by pressing (I).

NOTE

If the screen appears snowy, the monitor selection switch may be set to the wrong position. Set the monitor selection switch to the correct setting, then turn the system box's power switch off and on again.

The keyboard sounds a bell tone, and a pie graph displayed on the monitor gradually fills in as the terminal performs its self-tests.

When the tests are done, the keyboard bell tone sounds again and the Terminal Manager window appears.

This is a good time to set the brightness, contrast, and viewing angle of your monitor. See your monitor's installation guide for instructions.

If you installed optional memory cards, go to the next section to verify the memory installation.

Verifying the Memory Installation

After you power up the monitor and system box, the Terminal Manager window should appear on your screen.

Verify that the number on the right side of the Memory Remaining scale displays the correct number of megabytes in your system.

Standard	+	Optional	=	Number Displayed
2 megabytes		1 megabyte		3M
		2 megabytes		4M

The installation procedure is complete.

Refer to *Installing and Using the VT1200 Video Terminal* to learn how to use your DECimage 1200 terminal.

NOTE

If you had problems with the installation, review the installation steps carefully. If the problem continues, refer to the “Solving Problems” chapter in *Installing and Using the VT1200 Video Terminal*.

3

Installing Optional Memory

This chapter describes how to install optional SIMM memory cards onto the image board.

The terminal comes with 2 megabytes of RAM memory. You can add 1 or 2 more megabytes of optional RAM memory, for a total of up to 4 megabytes. Optional memory comes on 1-megabyte single in-line memory module (SIMM) cards. You install the SIMM cards on the terminal's image board.

Installation

Use a grounding wrist strap and an antistatic mat to perform the installation, if available. Otherwise, frequently touch the metal chassis of the system box during installation, to neutralize any existing static charges.

If you are installing the terminal, go to the next page.

If the terminal is already installed, perform these steps first.

Step	Action
1	Turn the system box's <input type="checkbox"/> power switch off (O).
2	Turn the monitor's <input type="checkbox"/> power switch off (O).
3	Disconnect the two power cords from the rear of the system box.
4	Disconnect the monitor video cable from the rear of the system box.
5	Remove the monitor from the top of the system box. You may need two people.

12 Installing Optional Memory

Install the SIMM cards.

Step	Action
1	Remove the system box cover. <ul style="list-style-type: none">• Release the top cover of the system box by pressing in the two push tabs on the side of the box, as shown.• Slowly lift the top cover until you release the hinges on the other side of the box. Then lift the top cover completely off the system box.

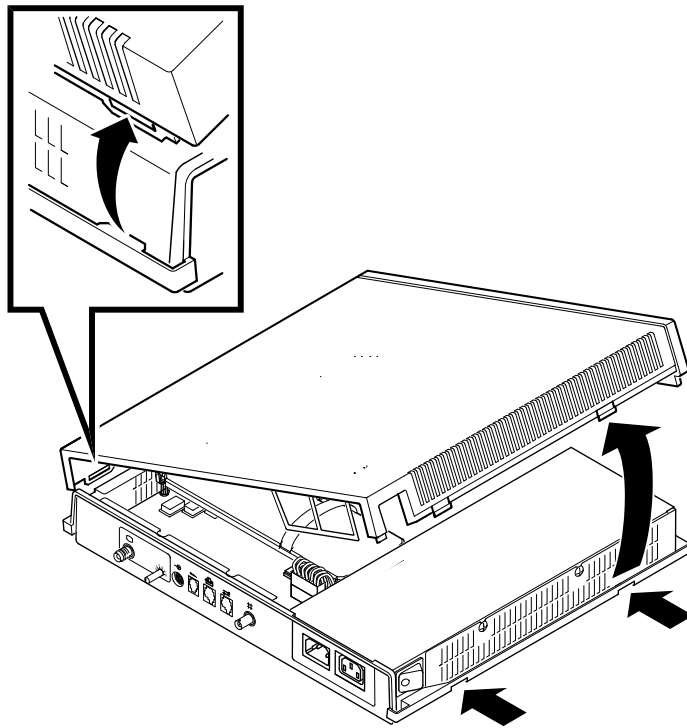

MA-0251-90.DG

Step Action

- 2 Remove the image board from the system box.

CAUTION

The image board and the SIMM cards can be damaged by electrostatic discharge. Handle the image board by its cover or strap. Avoid contact with any components or circuitry within the system box.

- Release three standoff clips (1, 2, 3) by gently pushing each clip away from the image board and lifting up on the edges of the board.
- Hold the short strap on the image board and *gently* pull up to loosen the board from the standoffs.
- Release the other three standoff clips (4, 5, 6) by gently pushing each clip away from the image board and lifting up on the edges of the board.
- Grasp the long strap of the image board and pull up firmly to release the image board connector from the system logic board.
- Place the board on top of the power supply's metal cover, with the strap side down. You will use the metal cover as a work surface to perform the SIMM card installation.

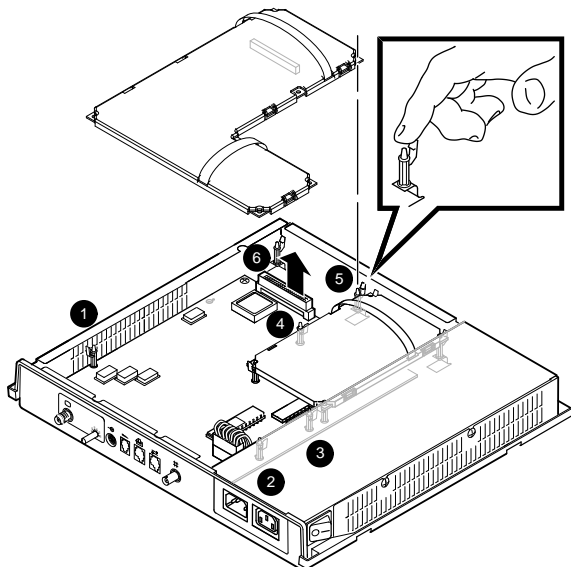

14 Installing Optional Memory

Step	Action
------	--------

- 3 Install the SIMM cards on the image board.

CAUTION

SIMM cards can be damaged by electrostatic discharge. Handle a card by its edges and avoid contact with the gold fingers on the card.

Remove the SIMM cards from the shipping bag and place them on top of the power supply's metal cover. This prevents electrostatic damage.

Install the first SIMM card in the connector labeled 2MB, the second SIMM in 3MB, and the last SIMM in 4MB.

- Insert the SIMM card into the connector at a 45-degree angle. Face the components on the SIMM card toward the components on the image board. Line up the center key slot on the SIMM card with the connector key on the image board.
- Push down on the top of the card to seat it in the connector.
- Raise the SIMM card into a standup position, until both sides of the card lock into the connector tabs.

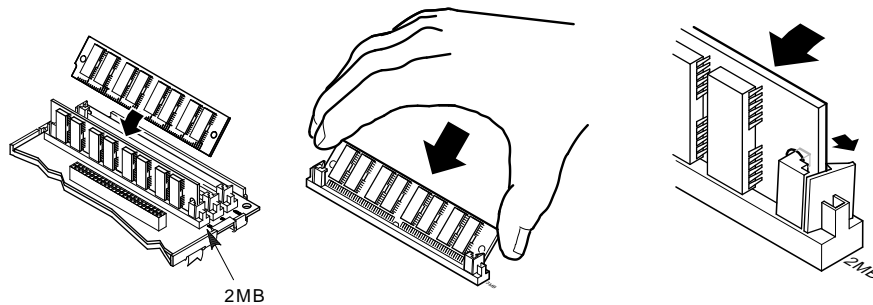

MA-0508-90.DG

To remove the SIMM card: Gently push outward on the tabs at the sides of the connector. Tilt the SIMM card toward the edge of the image board at a 45-degree angle. Grasp the edges of the SIMM card firmly and lift the card out of the connector.

Step	Action
4	Install the image board back into the system box. <ul style="list-style-type: none">• Grasp both straps of the image board.• Carefully place the board on top of its connector and standoffs. Use the standoffs as guides to align the connector on the board with the connector in the system box.• Press down firmly on the wide end of the board to seat the connector. Then, press down on the edges of the board to lock each of the six standoff clips.
5	Install the system box cover.
6	Place the monitor on top of the system box. Leave enough room at the rear of the system box and monitor to connect cables.

WARNING**If necessary, use two people to lift or move the monitor.**

- | | |
|---|---|
| 7 | Go back to Chapter 2, to connect the cables to the system box and verify the memory installation. |
|---|---|
-

4

Upgrading To a DECimage 1200 Terminal

This chapter provides the procedure to upgrade your terminal to a DECimage 1200 terminal.

CAUTION

The image board and the SIMM cards can be damaged by electrostatic discharge. Handle the image board by its cover or strap. Avoid contact with any components or circuitry within the system box.

Unpacking

Unpack and check the contents of each carton.

- ❶ Standoffs: 2 keyed and 1 unkeyed
- ❷ *Installing and Using the DECimage 1200 Video Terminal*
- ❸ Image board
- ❹ ROM board
- ❺ **Optional:** SIMM memory card(s)

Upgrading to a DECimage 1200 Terminal 17

1

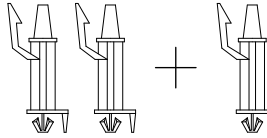

2



3

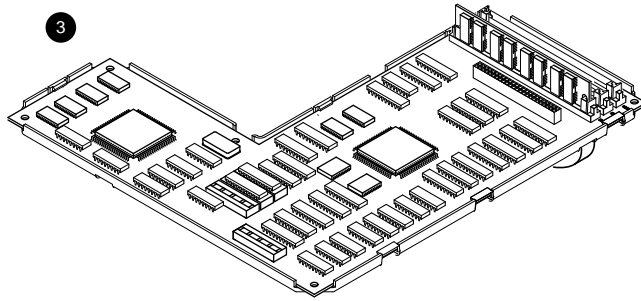

4

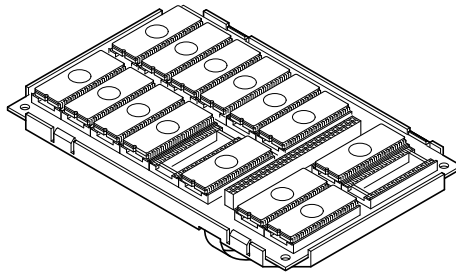

5

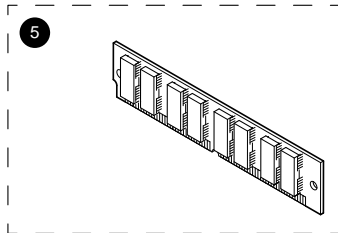

Installation

If you are unfamiliar with the connectors on the terminal's system box, refer to the figures in Chapter 2.

Use a grounding wrist strap and an antistatic mat to perform the installation, if available. Otherwise, frequently touch the metal chassis of the system box during installation, to neutralize any existing static charges.

Turn off power, disconnect cables, and open the system box.

Step	Action
1	Turn the system box's <input type="checkbox"/> power switch off (O).
2	Turn the monitor's <input type="checkbox"/> power switch off (O).
3	Disconnect the two power cords from the rear of the system box.
4	Disconnect the monitor video cable from the rear of the system box.
5	Remove the monitor from the top of the system box. You may need two people.
6	Remove the system box cover.

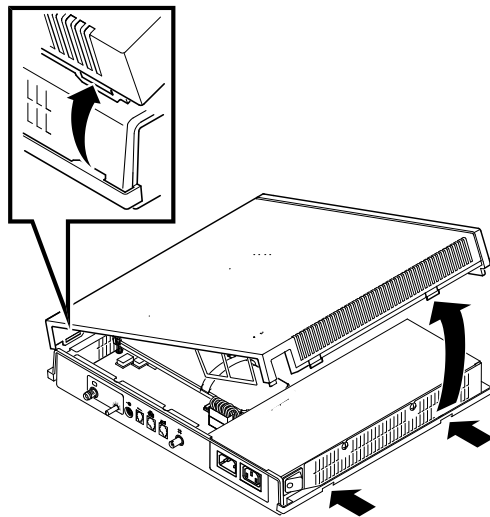

MA-0251-90.DG

Remove the RAM controller board and check for SIMM cards.

If your terminal does not have a RAM controller board ❶, go to the next page.

Step	Action
------	--------

- | | |
|---|--|
| 1 | Release the standoff clips on the RAM board ❶ and remove the board by firmly lifting up on its strap. |
| 2 | Turn the RAM board over and check if one or more SIMM cards ❷ are installed. If any SIMM cards are installed, remove them as follows:

Gently push outward on the tabs at the sides of the connector. Tilt the SIMM card toward the edge of the RAM board at a 45-degree angle. Grasp the edges of the SIMM card firmly and lift the card out of the connector.

Next, you will install the SIMM cards on the image board. |
-

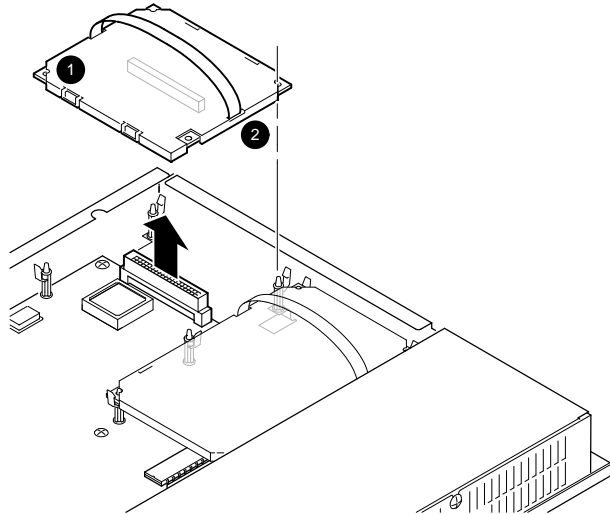

Install SIMM cards on the image board.

If you are not installing SIMM cards, go to the next page. If you ordered optional SIMM cards or removed SIMM cards from the RAM controller board, install them on the image board.

CAUTION

SIMM cards can be damaged by electrostatic discharge. Handle a card by its edges and avoid contact with the gold fingers on the card.

Step	Action
1	Remove the SIMM cards from the shipping bag and place them on top of the power supply's metal cover. This prevents electrostatic damage.
2	Install the first SIMM card in the connector labeled 2MB, the second SIMM in 3MB, and the last SIMM in 4MB. <ul style="list-style-type: none">• Insert the SIMM card into the connector at a 45-degree angle. Face the components on the SIMM card toward the components on the image board. Line up the center key slot on the SIMM card with the connector key on the image board.• Push down on the top of the card to seat it in the connector.• Raise the SIMM card into a standup position, until both sides of the card lock into the connector tabs.

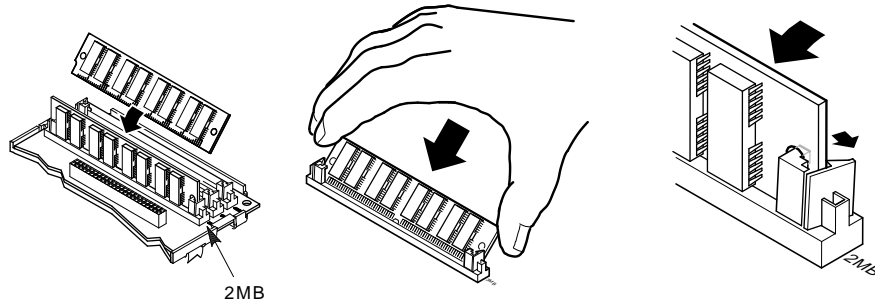

To remove the SIMM card: Gently push outward on the tabs at the sides of the connector. Tilt the SIMM card toward the edge of the image board at a 45-degree angle. Grasp the edges of the SIMM card firmly and lift the card out of the connector.

Install the image board in the system box.

Step	Action
1	Firmly bend and twist the standoff ❶ to break it and remove it. It is normal for the broken piece to remain inside the system box.
2	Install three new standoffs to support the image board: ❷ is unkeyed and ❸ and ❹ are keyed.
3	Grasp both straps of the image board.
4	Carefully place the board on top of its connector and standoffs. Use the standoffs as guides to align the connector on the board with the connector in the system box.
5	Press down firmly on the wide end of the board to seat the connector. Then press down on the edges of the board to lock each of the six standoff clips.

CAUTION

Pressing too hard on the narrow end of the image board may damage the board.

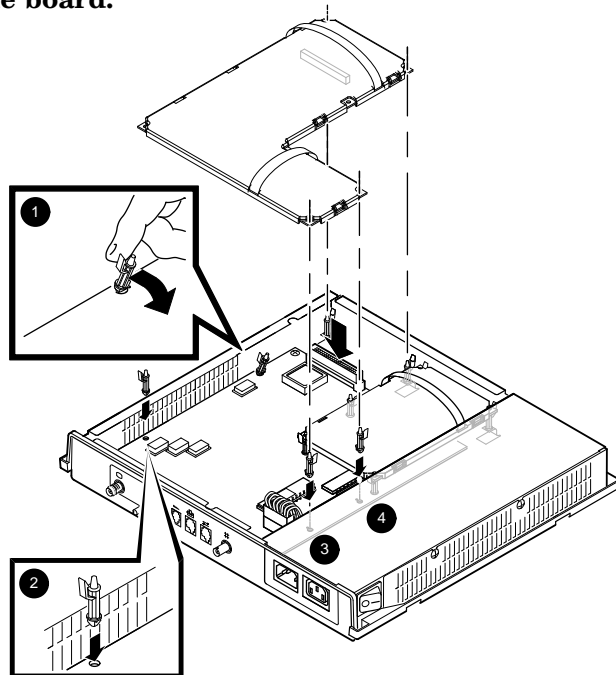

Install the new ROM board and verify the installation.

Step	Action
1	The ROM board is next to the image board. Remove the old ROM board from the system box by releasing the board's standoff clips and pulling up firmly on the board's strap.
2	Unpack the new ROM board and install it in the system box. Align the board with its connector, press firmly in place, and lock the standoff clips.
3	Install the system box cover.
4	Reconnect all cables to the monitor and the system box.
5	Turn on the power switches on the system box and monitor.

NOTE

If the screen appears snowy, the monitor selection switch may be set to the wrong position. To correct the problem, change the monitor selection switch setting and turn the system box power off and on again.

6	Go to the next section to verify the memory installation.
---	---

Verifying the Memory Installation

After you power up the monitor and system box, the Terminal Manager window should appear on your screen.

Verify that the number on the right side of the Memory Remaining scale displays the correct number of megabytes in your system.

Standard	+	Optional	=	Number Displayed
2 megabytes		1 megabyte		3M
		2 megabytes		4M

The installation procedure is complete.

Continue to refer to your VT1000 or VT1200 *Installing and Using ...* guide for information on using your DECimage 1200 terminal.

NOTE

If you had problems with the installation, review the installation steps carefully. If the problem continues, refer to the "Solving Problems" chapter in your VT1000 or VT1200 *Installing and Using ...* guide.

5

Improving Hard-to-Read Images

This chapter describes how to improve images that are hard to read on the screen. For example, you may have scanned-in images that are too light or dark, streaked, or smudged. You can use the Customize Image dialog box to improve the image currently displayed on the screen.

NOTE

Before using the dialog box, make sure you set the brightness and contrast controls on your monitor. See your monitor's installation guide for instructions.

How Does the Terminal Display an Image?

Your terminal displays text characters and graphic images as a series of dots (pixels) on the monitor's screen. The terminal reads the information for each dot from the image's source file. A typical source file for a printable document stores images at a resolution of 200 or 300 dots/inch.

The terminal displays images at a resolution of approximately 100 dots/inch. Terminals and monitors generally have a lower resolution than printers.

As a result, images that are flawed in the source file may be unreadable when displayed. For example, suppose you have a document with a broken E character. The character may be readable in the source file, but unreadable when the terminal displays it on the monitor's screen.

24 Improving Hard-to-Read Images

Stored

300 dots/inch

The terminal stores all recognized dots.

Displayed

100 dots/inch

The terminal displays one out of three dots stored.

LJ-00046-RAGS

How Can You Improve an Image?

If an image in a source file is imperfect or incomplete, you can improve the displayed image by changing its brightness and contrast values. For example, you may be able to improve broken characters enough so they are readable on the screen, by applying brightness or contrast values that fill in the characters.

When you adjust the brightness and contrast values of an image, the terminal recalculates the darkness level (black or white) of the displayed dots that make up the image.

Displaying the Customize Image Dialog Box

To display the Customize Image dialog box, choose the **Image** menu item from the Terminal Manager's Customize menu.

1. Point to the **Customize** menu name in the Terminal Manager's menu bar. Click and hold MB1 to pull down the Customize menu.

LJ-00043-RAGS

2. Drag the pointer down to the **Image...** menu item. Release MB1 to display the Customize Image dialog box.

The values on the Brightness and Contrast scales represent the last adjustments you made to an image and saved in the terminal's memory. There are two ways to save adjustments:

- Click on the **OK** or **Apply** button in the Customize Image dialog box
- Choose the **Save Current Settings** menu item on the Customize menu in the Terminal Manager window.

26 Improving Hard-to-Read Images

The terminal saves your settings in nonvolatile random access memory (NVR). If you did not save any values, the terminal displays the image with the values at 0.

LJ-00044-RAGS

Adjust

Normally, this option is disabled so the terminal can calculate its own brightness and contrast values for the displayed image. If you want to change the brightness or contrast values, click on the Enable button.

Default: Disable

NOTE

Remember to click on the Disable button before the OK button to close the Customize Image dialog box. If you leave Adjust enabled, the terminal may display other images with poor quality.

Brightness

This slide bar controls the density of the image on the screen.

Moving the brightness scale to the right darkens the characters and lines in the image.

The effect is reversed for applications that display light text on a dark background.

Default: The last values saved in the Customize Image dialog box.

Contrast

This slide bar controls the area of dots that are changed by the Brightness slide bar.

For example, if you set the Contrast slide bar and then move the Brightness slide bar to the right, selected areas of the image become darker and thicker.

Moving the Contrast slide bar to the right causes detailed characters and lines to merge. It also causes more background data to appear in the displayed image.

Default: The last values saved in the Customize Image dialog box.

Customizing the Image

Most hard-to-read images have broken characters or a smudged background.

NOTE

You can make the greatest changes to the image by making small adjustments at the ends of the Brightness and Contrast scales.

Improving Images with Broken Characters

You can improve images with incomplete characters by making adjustments to the Brightness and Contrast scales.

1. Display the image you want to adjust.
2. Click on the **Enable** button in the Customize Image dialog box.
3. Click on the Brightness scale pointer and drag the pointer to the right of center, closer to the right end of the scale.
4. Click on the **Apply** button in the Customize Image dialog box.
5. Redisplay the changed image from your application. Note how the new value changed the image.
6. Continue to make adjustments—moving the Brightness scale, clicking on **Apply**, and redisplaying the changed image—until you are satisfied with the results. The Contrast scale setting should be greater than 0 and closer to the left end of the scale.

28 Improving Hard-to-Read Images

7. After you finish customizing images, click on the **Disable** button before you click on **Apply**. This allows the terminal to calculate the brightness and contrast values of images.

Improving Images with Smudged Backgrounds

You can improve images that have smudged backgrounds or smudge marks by adjusting the Brightness and Contrast scales together.

1. Display the image you want to adjust.
2. Click on the **Enable** button in the Customize Image dialog box.
3. Click on the Brightness scale pointer and drag the pointer to the left of center.
4. Click on the Contrast scale pointer and drag the pointer closer to the left end of the scale.
5. Click on the **Apply** button in the Customize Image dialog box.
6. Redisplay the changed image from your application. Note how the new values changed the image.
7. Repeat these steps if necessary, making small adjustments until the image is easy to read.
8. After you finish customizing images, click on the **Disable** button before you click on **Apply**. This allows the terminal to calculate the brightness and contrast values of images.

6

Solving Problems

This chapter describes image display problems and solutions, for operators and programmers.

For other operating problems, see the “Solving Problems” chapter in *Installing and Using the VT1200 Video Terminal*.

Symptom	Suggested Solution
Display Problems: Operator-Related	
The screen appears snowy.	Set the monitor selection switch to the correct position. <ol style="list-style-type: none">1. Turn the system box's <input type="checkbox"/> power switch off (O).2. Turn the monitor selection switch setting on the rear of the system box to the correct position (Chapter 2).3. Turn the system box's <input type="checkbox"/> power switch on (I).
The power-up diagnostics are unsuccessful, and the pie graph is distorted.	Replace the ROM board with an image ROM board.
The displayed image is incomplete.	Check the image board by running the power-up diagnostics. Turn the system box's <input type="checkbox"/> power switch off (O) and on (I). Report the error on the screen to Digital Customer Services.

Symptom	Suggested Solution
Display Problems: Operator-Related	
Different images have different display qualities, or the quality changes when the application changes the image size.	The Adjust button in the Customize Image dialog box is enabled. Click on Disable to allow the terminal to calculate the brightness and contrast values of the image.
The terminal stops operating or displays error code 28 on the screen.	The terminal ran out of memory. Turn the system box's <input type="checkbox"/> power switch off (O) and on (I) to recover. Use fewer windows.
Display Problems: Programmer-Related	
The client receives a Bad Request X error.	Do not invoke an XIE request that is not implemented.
The client receives a Bad Request or Bad Match or Bad Value X error.	Do not invoke an XIE protocol request that is implemented, but violates its restricted use. This includes attempts to: <ul style="list-style-type: none"> • Create non-bitonal image objects. • Transport from the server to the client. • Transport DCT compressed data.
The client receives a Bad Match or Bad Value X error.	Ensure that the parameters passed to the protocol requests function are properly coded and within range limits.
The client receives a Alloc X error.	Use less server resources when the XIE request generating the error is invoked. For example, reduce the number of windows, the number of images in the server, and so on.
No image or a partial image is displayed.	Ensure that the transported image is properly coded by verifying the content of the image file at the client and verifying the client application.

Symptom	Suggested Solution
Display Problems: Programmer-Related	
	Check the image board by running the power-up diagnostics. Turn the system box's <input type="checkbox"/> power switch off (O) and on (I).
	Report the error on the screen to Digital Customer Services.

A

Specifications

This appendix lists site planning specifications for the VR315 and VR319 monitors. Refer to the “Specifications” appendix in the *Installing and Using the VT1200 Video Terminal* guide for additional information.

Site Planning

	Weight	Height	Width	Depth
VR315 monitor	13 kg (29 lb)	400 mm (15.7 in)	400 mm (15.7 in)	395 mm (15.4 in)
VR319 monitor	27.2 kg (60 lb)	457 mm (18 in)	495 mm (19.5 in)	452 mm (17.8 in)

Display

VR315 CRT	380 mm (15 inch) monochrome screen
resolution	100 dots/inch
VR319 CRT	485 mm (19 inch) monochrome screen
resolution	100 dots/inch

B

Options and Documentation

This appendix lists the manuals related to the DECimage 1200 video terminal. Refer to the “Options and Documentation” appendix in the *Installing and Using the VT1200 Video Terminal* guide for a listing and ordering information for options, modems, cables, and other manuals.

Related Documentation

You can order the following related documents from Digital:

<i>DEC Image Utility Library Programmer Reference Manual</i>	AA-PG62B-TE
Provides programmers with information on how to use software routines to manipulate an image in an X window image extension (XIE) environment.	
<i>DEC Image Utility Library for VMS Installation Guide</i>	AA-PG63B-TE
<i>DEC Image Utility Library for ULTRIX Installation Guide</i>	AA-PG8AA-TK
Provides installers with information to install the Image Utility Library on VMS systems or ULTRIX systems.	
<i>VT1000 / VT1200 / DECimage 1200 Service Guide</i>	EK-V1000-SV
Provides qualified service personnel with information to troubleshoot and repair the VT1000, VT1200, and DECimage 1200 terminals.	
<i>VR315 Monitor Service Guide</i>	EK-VR315-SV
Provides qualified service personnel with information to troubleshoot and repair the VR315 monitor.	
<i>VR319 Monitor Service Guide</i>	EK-VR319-SV
Provides qualified service personnel with information to troubleshoot and repair the VR319 monitor.	
<i>VRE01 Service Guide</i>	EK-VRE01-SV
Provides qualified service personnel with information to troubleshoot and repair the VRE01 flat panel display.	

C

X Window Image Extensions

The DECimage 1200 terminal includes X window image extensions (XIE), an extension to the DECwindows server. With XIE:

- The terminal can handle compressed images for display.
- The server can manipulate the images while accepting user input and client-based application programs.

The XIE server for the terminal uses a subset of the XIE protocol to display document-size, bitonal images only.

The XIE Subset

Table C-1 lists the XIE requests that the terminal supports. When you use XIE requests in programs, you must obey the following rules and restrictions so your program will be compatible with the XIE server.

Pipelines

Always use pipelines to display images on the terminal.

XIE uses process control services, known as *pipelines*, to allow a client to create and execute linear, macro-like assemblies of protocol primitives. Pipelining is a single threaded list of XIE protocol functions through which image data flows sequentially.

When you construct pipelines for the terminal, the following restrictions apply:

- Pipeline definitions
 - Must use the following functions only: scale, crop, rotate, mirror, and export.
 - Must not have more than one scale, crop, rotate, mirror, and export function.
 - Must always end with the export function.

- Prefer the following order: scale, crop, rotate, mirror, and export.
- Must be limited to 15 pipeline definitions at one time.
- After you display an image, free the resources used by the rendered image. Also, rerender from the transported image, if necessary.
- Specify a request to rotate as 0, 90, 180, or 270 degrees only.
- Specify the width and height to be 0, or to match the width and height of the rotated source image. XIE ignores other values.
- Specify the XIEP_TAP_PHOTOFLO request after the creation of the photoflo, which is when no elements are added to the pipeline. XIE ignores other taps.

Decompression Constraints

XIE limits image decompression to CCITT Group 3 and 4 images with scaling widths of less than or equal to 32768 pixels. CCITT is the *Comité Consultatif International de Télégraphique et Téléphonique*, a standards committee for the communication industry in Europe.

Scaling Constraints of the XIE Server

The server may adjust the scale factors used by the image board from those specified in the XIEP_SCALE request. Any adjustment will be close to the specified scale, but will not exceed the specified scale.

The server restricts the scale factors because of the word size of the image accelerator. To scale A pixels to B pixels, find the corresponding M and N , respectively, that satisfy the following constraints. N/M should be as close as possible to B/A , without exceeding B/A .

- When scaling down ($A \geq B$, $M \geq N$), the constraints are

$$N < 64, \text{ then } N \leq M \leq N + 64$$
- When scaling up ($A \leq B$, $M \leq N$), the constraints are

$$M < 64, \text{ then } M \leq N \leq M + 64$$

XCopArea and XCopyPlane Constraint

When displaying an image by copying from a pixmap to a partially occluded window using XCopyArea or XCopyPlane, Xie may display some or all of the image in reverse video in the window that is partially occluded. You can correct the video sense of the image by removing the occlusion and causing the image to be displayed again.

XIE Functions

Table C–1 describes the XIE functions that the terminal supports. The table also describes restrictions for each function.

Table C–1 XIE Functions in the DECimage 1200 Terminal

Session Services	Description
XIEP_INIT_SESSION	Begins a client-extension server session. Restrictions: None.
XIEP_SET_OP_DEFAULTS	Establishes or modifies operational defaults. Restrictions: Bits/pixel parameter value must be 1.
XIEP_QUERY_OP_DEFAULTS	Queries operational defaults. Restrictions: None.
XIEP_TERM_SESSION	Ends a client-extension server session. Restrictions: None.
Resource Services	Description
XIEP_CREATE_BY_VALUE	Creates a new server resource object. Restrictions: Resource-manipulation parameter values are restricted to those compatible with bitonal images.
XIEP_CREATE_BY_REFERENCE	Creates a new server resource object. Restrictions: Resource-manipulation parameter values are restricted to those compatible with bitonal images.
XIEP_DELETE_RESOURCE	Deletes an existing resource object. Restrictions: None.

Table C-1 (Cont.) XIE Functions in the DECimage 1200 Terminal

Resource Services	Description
XIEP_QUERY_RESOURCE	Queries an existing server resource object. Restrictions: Resource-manipulation parameter values are restricted to those compatible with bitonal images.
XIEP_EXPORT	Creates a new server PIXMAP resource object. Restrictions: None.
XIEP_FREE_EXPORT	Frees the export context. Restrictions: None.
XIEP_QUERY_EXPORT	Queries the export context. Restrictions: None.
Transport Services	Description
XIEP_SET_TRANSPORT	Establishes the required transport context information. Restrictions: Does not support a DCT compression scheme.
XIEP_ABORT_TRANSPORT	Stops the required transport context information. Restrictions: None.
XIEP_PUT_TILE	Transports random tiles of uncompressed image data from the client to the server. Restrictions: None.
XIEP_PUT_STREAM	Transports a stream of compressed or uncompressed image data from the client to the server. Restrictions: Does not support a DCT compression scheme.

Table C-1 (Cont.) XIE Functions in the DECimage 1200 Terminal

Geometric	Description
XIEP_SCALE	Scales the image in x and y directions. Restrictions: Limits the scale factor within specifications. See the “Scaling Constraints of the XIE Server” section.
XIEP_ROTATE	Rotates the image around the z axis. Restrictions: Supports 0, 90, 180, and 270-degree rotation only. The width and height should either be 0 or match the width and height of the rotated source image. XIE ignores other values.
XIEP_MIRROR	Rotates the image around the x or y axis, or both. Restrictions: None.
XIEP_CROP	Extracts a subset of an image. Restrictions: None.
Process Control Services	Description
XIEP_EXECUTE_PHOTOFOLO	Begins the execution of a pipeline. Restrictions: See the “Pipelines” section.
XIEP_ABORT_PHOTOFOLO	Terminates (prematurely) the execution of a pipeline. Restrictions: None.
XIEP_BIND_PHOTOFOLO	Binds a photomap to a photoflo. Restrictions: None.

Table C-1 (Cont.) XIE Functions in the DECimage 1200 Terminal

Process Control Services	Description
XIEP_TAP_PHOTO Flo	Captures the current output image of the photoflo at the point where the tap was issued. Restrictions: Tap only at the beginning of a pipeline (when empty). XIE ignores other taps.
XIEP_SELECT_EVENTS	Selects the events that the client wishes to be notified of. Restrictions: None.
XIEP_QUERY_EVENTS	Queries which events the client will be notified of. Restrictions: None.

