

USER'S INFORMATION MAP

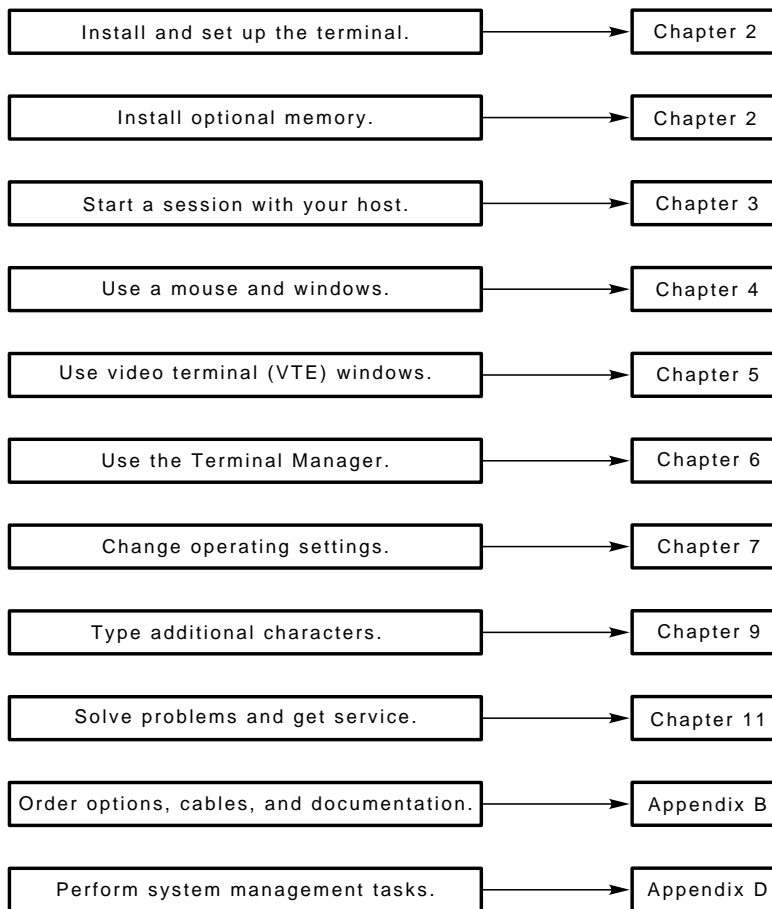

MA-0670-90A.DG

This document was prepared and published by Educational Services Development and Publishing, Digital Equipment Corporation.

Installing and Using The VT1200 Video Terminal

Order Number EK-V1200-UG-001

Digital Equipment Corporation

First Edition, July 1990

The information in this document is subject to change without notice and should not be construed as a commitment by Digital Equipment Corporation. Digital Equipment Corporation assumes no responsibility for any errors that may appear in this document.

The software described in this document is furnished under a license and may be used or copied only in accordance with the terms of such license.

No responsibility is assumed for the use or reliability of software on equipment that is not supplied by Digital Equipment Corporation or its affiliated companies.

Restricted Rights: Use, duplication, or disclosure by the U. S. Government is subject to restrictions as set forth in subparagraph (c) (1) (ii) of the Rights in Technical Data and Computer Software clause at DFARS 252.227-7013.

Copyright © by Digital Equipment Corporation 1990

All Rights Reserved.
Printed in Taiwan.

FCC NOTICE: The equipment described in this manual generates, uses, and may emit radio frequency energy. The equipment has been type tested and found to comply with the limits for a Class A computing device pursuant to Subpart J of Part 15 of FCC Rules, which are designed to provide reasonable protection against such radio frequency interference when operated in a commercial environment. Operation of this equipment in a residential area may cause interference, in which case the user at his own expense may be required to take measures to correct the interference.

AT&T and UNIX are trademarks of the American Telephone and Telegraph Company.

X Window System is a trademark of the Massachusetts Institute of Technology.

The following are trademarks of Digital Equipment Corporation:

DEC	DECwindows	PDP	ThinWire
DECcall	DECwriter	P/OS	ULTRIX
DECconnect	DIBOL	Professional	ULTRIX-32
DECmailer	LA	Q-bus	UNIBUS
DECmate	LA50	Q22-bus	VAX
DECnet	LA75 Companion	Rainbow	VAXstation
DECserver	LN01, LN03	ReGIS	VMS
DECservice	LN03 PLUS	RSTS	VR150
DECstation	LQP02	RSX	VT, VT52, VT100
DECsupport	MASSBUS	RT	VT220, VT320, VT420
DECterm	MicroPDP	Scholar	VT1200
DECUS	MicroVAX	SERVcenter	

digital™

Contents

About This Guide	xi
1 A Look at the Terminal	
VT1200 Components	2
System Box	2
Monitor	2
Keyboard	3
Mouse	3
X Window Sessions and Video Terminal Sessions	3
X Window System and DECwindows	3
System Requirements	4
VMS Systems: LAT Protocol	4
UNIX and ULTRIX Systems: TCP/IP TELNET Protocol	4
How the Terminal Works	5
Terminal Highlights	6
Customizing Your Terminal	7
Compatibility with VT Series Terminals	7
Character Sets	7
Programming the Terminal	7

Installing Your Terminal

2 Installing Your Terminal

Site Preparation	11
Selecting a Location	13
Installation	14
Installing Memory	21
Installing RAM Memory	24
Installing the ROM Board	28

3 Getting Started

Terminal Manager Window	32
Choosing the Display Language	32
Choosing the Correct Keyboard Type	34
Starting a Session on Your Host System	35
Starting a Video Terminal or X Window Session on a VMS System	36
Starting a Video Terminal or X Window Session on an ULTRIX or UNIX System	41
Starting a Video Terminal Session on the Serial Host Port	47
Ending a Session	47

Using Your Terminal

4 Using Windows

DECwindows Differences	51
Before You Start	52
Using the Mouse	52
What Are Windows?	54
Using Windows	55
Selecting Windows	55
Moving Windows	56
Changing the Size of Windows	57
Shrinking Windows to Icons	58
Expanding Icons to Windows	59

Stacking Overlapping Windows	59
Choosing Items from Pull-Down Menus	60
Supplying Information in Dialog Boxes	61
Moving and Changing Settings in a Dialog Box	63
Using Scroll Bars	64
5 Using Video Terminal (VTE) Windows	
VTE Window Format	66
Clearing, Resetting, or Leaving the Session	68
Copying and Pasting Text	69
Host Synchronization Required	70
Selecting Text to Copy	71
Pasting Text	71
Using QuickCopy	72
Customizing the VTE Window	73
Displaying the Customize Menu	74
Saving and Recalling Settings	75
Changing Your VTE Window Settings	76
Changing Your VTE Display Settings	78
Changing Your VTE General Operating Features	80
Changing Your VTE Keyboard Features	84
Choosing National Replacement Character Sets	86
Printing from a Video Terminal Window	88
6 Using the Terminal Manager	
Terminal Manager Window	91
Creating Sessions on a Host System	93
Creating a Video Terminal Window on a VMS System	95
Creating an X Window Session on a VMS System	99
Creating a Video Terminal Window or X Window Session on an ULTRIX or UNIX System	101
Creating a Video Terminal Window on the Host or Printer Port (VMS, ULTRIX, or UNIX)	103
Creating a TCP/IP X Window Session	104
Pausing or Ending Sessions	105
Pausing a Session	105

Ending a Session	107
Customizing Your Terminal's Environment	109
Printing the Screen	109

7 Customizing the Terminal Manager

Displaying the Customize Menu	112
Saving and Recalling Settings	113
Changing Your Keyboard Settings	114
Choosing the Display Language	117
Changing Your Pointer and Mouse Settings	118
Changing Your Print Screen Settings	120
Changing Your Security Settings	122
Locking Your Customize Dialog Boxes	125
Activating Customize Password Security	127
Changing Your Window Settings	129
Controlling the Display of Messages	132
Changing Your Host Port or Printer Port Settings	134
Changing Your LAT Settings	138
Changing Your TCP/IP Settings (ULTRIX and UNIX Systems)	142
Changing Your TCP/IP Name Server Settings	144
Changing Your TCP/IP Routing Table Settings	145
Changing Your Font Path Settings	147

8 The Keyboard

LK401 Keyboard	151
Keyboard Dialect	151
Layout	151
Main Keypad	152
Editing Keypad	155
Numeric Keypad	155
Top-Row Function Keys	156
Data Processing Keys	158
Compose Characters	158
Indicator Lights	159

Audible Indicators	159
Keyclick	159
Bell	159
9 Typing Additional Characters	
What Characters Can I Type?	162
Key Sequences with Nonspacing Diacritical Keys	162
How to Type a Character Using the Compose Character Key	163
How to Type a Character Using the Group Shift Key	163
Invalid Sequences	164
Canceling or Restarting a Key Sequence	164
Hexadecimal Key Sequences	165
10 VTE Programming Summary	
Locator Device Commands	170
Enable Filter Rectangle (DECEFR)	171
Enable Locator Reports (DECELR)	172
Locator Report (DECLRP)	173
Request Locator Position (DECRQLP)	175
Select Locator Events (DECSLE)	176
Programming Summary	177
11 Solving Problems and Getting Service	
Operating Problems	184
Power-Up Self-Test	188
Screen Error Messages	188
Digital Service	189
How To Get Service	190

A Specifications

Site Planning	191
Environment	192
Electrical	192
Display (Monochrome Monitors)	192
LK401 Keyboard	193

B Options and Documentation

Optional Memory	195
Modems	195
Cables	196
Related Documentation	196
Ordering Information	197

C Communication

Network Protocols	198
Serial Communication	199
Serial Communication Cables	200
Serial XON/XOFF Flow Control	200
Modems	201
Modem Connections and Disconnections	201
Break Function	202
Communication Connector Signals	202
Pin Signals for the Pointing Device Connector	204
Standards	204

D System Management Tasks

Preparing the LAT Environment (VMS Systems)	205
Preparing the TCP/IP Environment (ULTRIX and UNIX Systems)	206
Running a Remote X Window Session on a VMS System	215

Glossary

Tables

9-1	Keyboards with Diacritical Marks	162
9-2	Key Sequences for Additional Characters	167
10-1	Primary DA Alias Responses from the Terminal	183
10-2	Control Function Requests (non-VT320)	183
11-1	Operating Problems	184
C-1	6-Pin DEC-423 Communication and Printer Interface Signals	203
C-2	Pin Assignments for the Pointing Device Connector	204

About This Guide

This guide is designed to help you install, operate, and maintain your VT1200 video terminal. The guide provides information on how to open X window or video terminal sessions on a VMS, ULTRIX, or UNIX system.

Who Should Use This Guide

This guide is for the installer and general user of the VT1200 video terminal. The guide also provides programmers with a summary of control functions they can use when writing applications for video terminal (VTE) windows.

Organization

This guide contains the following chapters and appendices:

- Chapter 1, “A Look at the Terminal,” provides an overview of the terminal and its features.
- Chapter 2, “Installing Your Terminal,” describes how to install your terminal and connect it to a host computer system. The chapter also describes how to install optional RAM and ROM boards.
- Chapter 3, “Getting Started,” describes how to start a session on your host system. You can use the terminal with VMS, ULTRIX, or UNIX systems.
- Chapter 4, “Using Windows,” describes how to to manipulate windows, choose menu items, and edit text. The chapter also shows how to use the mouse.
- Chapter 5, “Using Video Terminal (VTE) Windows,” describes how to use video terminal (VTE) windows. VTE windows let you emulate Digital’s VT series of text terminals.

- Chapter 6, “Using the Terminal Manager,” describes how to use the Terminal Manager window. You use this window to begin and end sessions with a host system.
- Chapter 7, “Customizing the Terminal Manager,” describes how to customize the terminal’s operating settings for your computing environment and personal preference.
- Chapter 8, “The Keyboard,” describes the function of the keyboard’s keys, bells, and indicator lights.
- Chapter 9, “Typing Additional Characters,” describes how to enter characters that do not appear as standard characters on your keyboard (for example, accented letters).
- Chapter 10, “VTE Programming Summary,” provides programmers with a quick-reference summary of VT1200 programming control functions for video terminal (VTE) window applications.
- Chapter 11, “Solving Problems and Getting Service,” describes how to solve typical operating problems and directs you where to get more help.
- Appendix A, “Specifications,” lists the terminal’s specifications.
- Appendix B, “Options and Documentation,” lists options, related documentation, and ordering information.
- Appendix C, “Communication,” provides technical information on communication with a host computer system. The appendix describes network protocols for LAT and TCP/IP connections, as well as serial communication.
- Appendix D, “System Management Tasks,” describes tasks for system managers to perform before installing and running the terminal. The appendix also describes how to run a remote X window session on a VMS system.
- The glossary defines new terms introduced in the text.

Conventions

The following conventions are used in this manual:

Mouse	Refers to any pointing device, such as a mouse, a puck, or a stylus.
MB1, MB2, and MB3	MB1 indicates the left mouse button. MB2 indicates the middle mouse button. MB3 indicates the right mouse button. (The buttons can be redefined by the user.)
Keyboard keys	Keys or switches that are labeled appear in a <code>box</code> . Example: Press the <code>Return</code> key.
<code>Ctrl</code> <code>key</code>	For <code>Ctrl</code> key sequences, hold down <code>Ctrl</code> and press the other key.
Warnings	Provide information to prevent personal injury.
Cautions	Provide information to prevent damage to equipment or software.
Notes	Provide general information about the current topic.
Glossary entries	Appear in <i>italics</i> when first used in text.

Note to the Reader

The screens and windows shown in this guide represent the latest information available at the time of publication. Some screens and windows may not exactly match those that appear on your terminal.

1

A Look at the Terminal

This chapter introduces you to the VT1200 video display terminal. The chapter provides an overview of the terminal and its basic operating features. The chapter also tells you where to look in this manual for more information about each feature.

The VT1200 lets you run X window applications on your computer system, including Digital's DECwindows software. The VT1200 also provides video terminal (VTE) windows that are compatible with VT series text terminals.

You can use the terminal with one or more computer systems. The VT1200 can work with computers that use the VMS, UNIX, or ULTRIX operating systems. You have several options for connecting your terminal to a computer.

You can use a mouse or keyboard to send information to the host system. You can print data displayed on the screen by connecting a printer to the terminal's system box or by using printers connected to your host system.

2 A Look at the Terminal

VT1200 Components

The terminal has four main components: a system box, monitor, keyboard, and mouse.

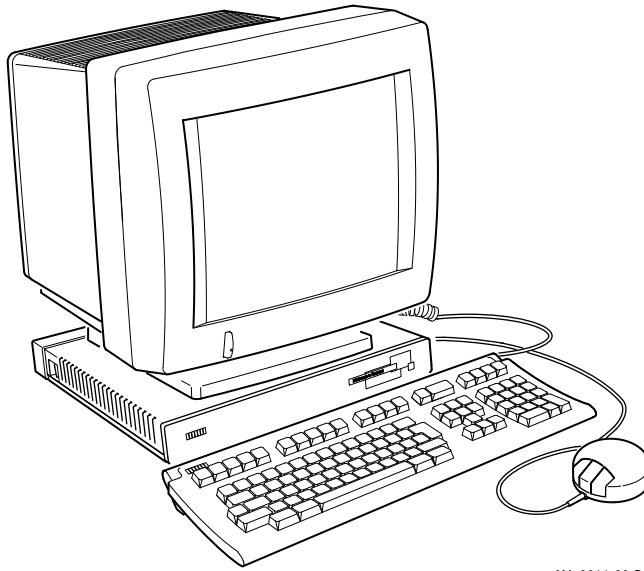

MA-0811-90.DG

System Box

The system box contains the terminal's logic and memory boards. It also provides the connectors for power, system communication, and other devices. A cover panel attaches to the rear of the system box to conceal the connectors and cables. The system box is 368 mm deep × 394 mm wide × 57 mm high (14.5 inches × 15.5 inches × 2.25 inches).

Monitor

The terminal comes with one of the following monochrome monitors:

- VR315 (380 mm/15 inch) with tilt-swivel stand
- VR319 (480 mm/19 inch) with tilt-swivel stand
- VRE01 (480 mm/19 inch) flat panel display

When connected to a host system, the monitor displays information you send to the host system and information the host system sends to you. For more information about your monitor, see your monitor's installation guide.

Keyboard

The keyboard has four groups of keys and two indicator lights. The keyboard cable connects to the system box. Chapter 8 describes the keyboard.

Mouse

The mouse is a three-button pointing device. You use the mouse to make selections from screen menus, enter data for graphics, or select points on the screen. The mouse connects to the system box. Chapter 4 describes how to use the mouse.

X Window Sessions and Video Terminal Sessions

You can use two types of sessions on your host computers:

X Window Session

To use an X window session, you log in to a host and use that host's X window software. In an X window session, you can use all the applications and utilities provided in the X Window System. For more information about Digital's X applications, see the VMS or ULTRIX version of the *DECwindows User's Guide*.

Video Terminal Session

You can use your VT1200 as a video text terminal. The VT1200 has a video terminal (VTE) window that lets you log in to a host as you would on a conventional video terminal. The VTE window offers most of the features of Digital's VT320 text terminal with some enhancements.

You can open one X window session and several VTE sessions at the same time.

X Window System and DECwindows

The X Window System is a graphically oriented user interface that lets you display one or more windows on the screen. Each window can represent a different *software application* running on its own host system. For example, you could run a word processing application in one window and a spreadsheet application in another window. With windows, you can perform many tasks in an easy and efficient manner.

The X Window System was designed at the Massachusetts Institute of Technology. Digital's DECwindows software is based on and fully compatible with the X Window System.

System Requirements

You can use your terminal with the VMS, ULTRIX, and UNIX based systems.

VMS Systems: LAT Protocol

The VMS operating system is one of Digital's operating systems. To make network connections to a VMS host system, use the local area transport (LAT) protocol. LAT is a communications protocol for connecting to VMS host systems.

To open a video terminal (VTE) session: You can use any version of the VMS operating system.

To open an X window session: You must have VMS Version 5.3-1 or higher installed on your system, and your system manager must enable certain options (Appendix D).

UNIX and ULTRIX Systems: TCP/IP TELNET Protocol

The UNIX operating system was created by AT&T and is used throughout the computer industry. The ULTRIX operating system created by Digital is based on the UNIX operating system. To make network connections to a UNIX or ULTRIX host, you normally use the transmission control program/Internet protocol (TCP/IP) networking software. TCP/IP is the preferred communication protocol for UNIX-based systems.

The VT1200 uses the TCP/IP TELNET protocol to make network connections to UNIX-based host systems. TELNET is the TCP/IP protocol that lets terminals connect to host systems in a wide-area network.

To open a video terminal session: You can use any version of UNIX or ULTRIX.

To open an X window session: You can use any version of UNIX to open an X window session, as long as any X11R3 client is installed on that host. ULTRIX workstation (UWS) versions 2.1 and higher include an X11R3 client.

How the Terminal Works

You can use the VT1200 with one or more computer systems. You have several options for connecting your terminal to a computer. You can connect the terminal directly to a computer through one of two serial ports, or you can connect the terminal indirectly through an Ethernet network using the ThinWire port.

The computer system you connect to is called the *host*. You can connect several VT1200 terminals to a single host or connect one VT1200 terminal to several hosts.

You use the keyboard and mouse to interact with applications on your system. You send data to the application by typing on the keyboard or selecting window options with the mouse. Data sent by the application appears as text or graphics on the screen. You can print text or graphics from the terminal.

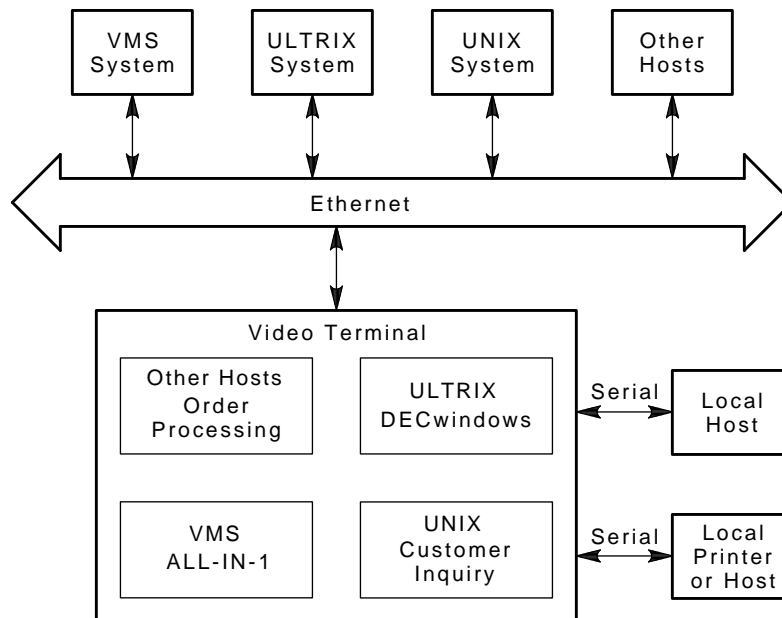

MA-0763-90A.DG

6 A Look at the Terminal

You can use a variety of host software applications on the terminal. For example, your host may have applications for word processing, data entry, programming, or business graphics. Most applications involve interactive processing. This means the terminal immediately sends the information you enter from the mouse or keyboard to the host.

Applications use programming functions to perform many operations. The terminal can work with standard American National Standards Institute (ANSI) functions. See Chapter 10.

Terminal Highlights

The VT1200 terminal is a four-piece desktop unit that provides many of the features of a workstation. The terminal provides you with the following features:

- A workstation-style display, resolution, keyboard, and mouse
- An X Window System desktop server for efficient interaction with DECwindows and X window applications
- A local window manager that lets you move and resize windows
- A local terminal manager that lets you create, manage, and delete connections to hosts
- A local video terminal (VTE) window that lets you use the VT1200 as a conventional video terminal
- Access to VMS, ULTRIX, and UNIX operating system software at the same time
- Serial interfaces for a keyboard and a mouse or tablet
- Two serial lines with DEC-423 connectors for serial host communication and printer support, like a traditional terminal
- A ThinWire Ethernet port to connect to an Ethernet network
- Two megabytes of RAM memory, with the option to add two more megabytes

The RAM board is user installable.

Customizing Your Terminal

You can check and control the settings of the terminal's operating features. You can

- Change individual feature settings.
- Recall factory-default settings or your own stored settings from memory.
- Make temporary changes for the current session or store new settings for all future sessions.

Chapter 7 describes how to customize your terminal settings.

Compatibility with VT Series Terminals

The VT1200 can operate as a video text terminal when you want to log in to a host system as you would with a conventional video terminal. You can use the terminal as one of Digital's VT320, VT220, VT102, VT101, or VT100 text terminals. Chapter 5 describes the video terminal (VTE) window and how to use it.

Character Sets

When you use video terminal (VTE) windows, you can choose different character sets to match your computer system or software application requirements. You can choose from:

- Two 8-bit multinational character sets—DEC Multinational or the ISO Latin Alphabet No. 1 set of the International Standards Organization
- Several 7-bit national replacement character sets (NRCs) for Western European languages

Chapter 5 describes how to choose characters sets.

Programming the Terminal

The VT1200 video terminal (VTE) windows emulate Digital's VT320 text terminal. The *VT320 Programmer Reference Manual* explains the control functions used to access the terminal's video terminal (VTE) window features. Chapter 10 of this user guide is a summary of VT1200 specific control functions and commands. Programmers use these functions in their applications.

Installing Your Terminal

2

Installing Your Terminal

This chapter provides step-by-step instructions on how to:

- Prepare for installation.
- Unpack, inspect, and check the terminal's components.
- Connect your terminal to a monitor, mouse, and keyboard.
- Connect your terminal to a network.
- Turn on your terminal.
- Connect an optional printer, modem, or tablet.
- Install an optional memory board.

Carefully read all installation instructions before you turn on the power.

Site Preparation

Before you install your terminal, make sure your computer system has the necessary network hardware and system software to support the terminal. See your system manager to make sure these requirements are met.

For System Managers

System managers need to prepare the system for use with the terminal. Appendix D describes the required tasks.

12 Installing Your Terminal

Network Hardware Support

The terminal requires one of the following physical connections to connect to a host computer system:

ThinWire connector Lets the terminal operate with X window applications and multiple text terminal sessions, using either the LAT or TCP/IP network protocol. You must use the ThinWire connector to operate with X window or DECwindows software.

Serial line Lets the terminal connect to a single host or terminal server as a traditional text terminal.

System Software Support

The following table summarizes the system resources needed to open X window sessions or video terminal (VTE) sessions:

Operation	Operating System	Communication Protocol
Video terminal session	VMS Version 4.0	LAT
	UNIX (any version)	TELNET (TCP/IP)
	ULTRIX (any version) UWS Version 2.2	TELNET (TCP/IP) LAT
X window session	VMS Version 5.3-1 or higher	LAT
	UNIX (any version)	TCP/IP TFTP (UDP) for font service
	UWS Version 2.1 (includes ULTRIX Version 3.1) or higher	TCP/IP TFTP (UDP) for font service

Selecting a Location

Use the following guidelines to select a good location for your terminal:

- Select a surface area that is large enough to hold your system box, monitor, keyboard, and mouse.
- Select a location near ac power outlets and communication connectors.
- Keep your terminal away from heaters, photocopiers, direct sunlight, and abrasive particles.
- Do not block the air vents on the sides of the system box or place the system box on its side. Blocking the air vents can cause the system to overheat.
- To avoid screen glare, select a place where bright light will not reflect off the monitor.
- Place your monitor so that the top line of the monitor display is at eye level.
- Keep the air well circulated, to prevent excess heat and dust from accumulating.
- Keep the temperature between 10° and 40° C (50° and 104° F), and the relative humidity between 10% and 95%.
- Keep the area clean. Do not place food or liquid on or near your terminal.

Installation

Unpack and check the contents of each carton.

1. Look for external damage on the shipping cartons, such as dents, holes or crushed corners.
2. Unpack the shipping cartons.

WARNING

If necessary, use two people to lift or move the monitor out of the shipping carton. The approximate weight of the monitor is

- **VR315 monitor (380 mm/15 inch): 13 kg (29 lb)**
 - **VR319 monitor (480 mm/19 inch): 27 kg (60 lb)**
 - **VRE01 monitor (480 mm/19 inch): 8 kg (15 lb)**
3. Make sure you have all the items shown in the following figure. Carefully inspect the components for shipping damage. If you have missing or damaged items, contact your sales representative and delivery agent.

CAUTION

If you received optional memory boards, do not remove them from the antistatic bag at this time. Static electricity can damage memory boards.

4. Save the empty shipping cartons and packing material for repacking, in case you move or relocate your terminal.

Install any optional memory first.

If you ordered additional memory for your terminal, go to the “Installing Memory ” section at the end of this chapter. You should install memory boards in the system box before proceeding.

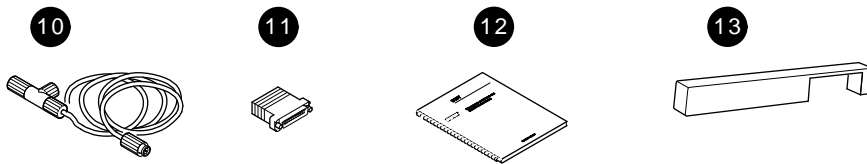
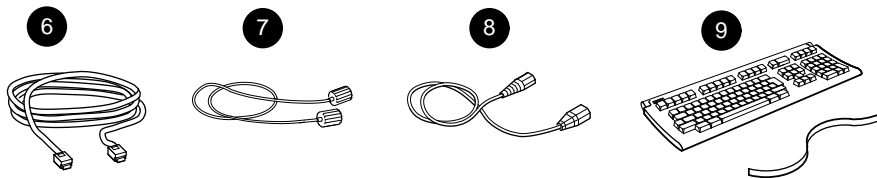
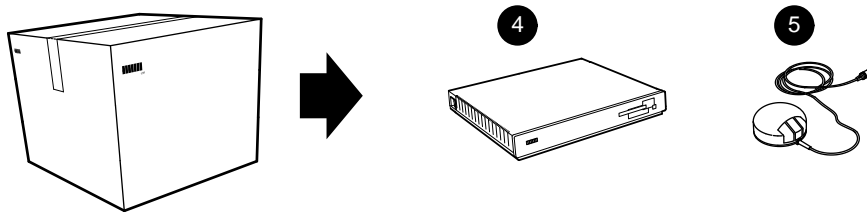
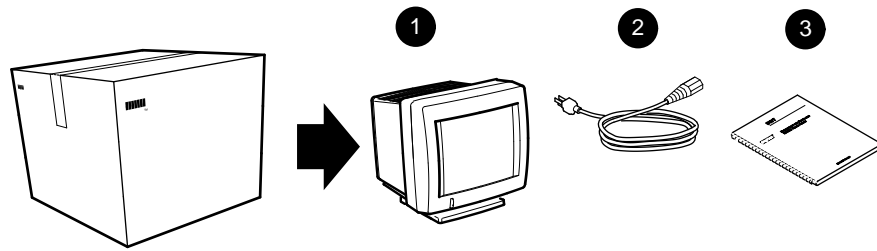

16 Installing Your Terminal

Parts Checklist

- ① Monitor: VR315, VR319, or VRE01
- ② System box power cord
- ③ Monitor installation guide
- ④ System box
- ⑤ Mouse
- ⑥ DEC-423 communication cable
- ⑦ Monitor cable
- ⑧ Monitor power cord
- ⑨ Keyboard and legend strip
- ⑩ Ethernet cable and connector
- ⑪ EIA adapter (DEC-423 6-pin to 25-pin)
- ⑫ *Installing and Using the VT1200 Video Terminal*
- ⑬ Rear dress panel

Options (See “Installing Memory ”)

- SIMM card(s)

NOTE

If you receive three power cords (a short one and two long ones), the second long power cord is not needed for this installation.

Place the system box on a level surface. Place the monitor on top of the system box.

Leave enough room at the rear of the system box and monitor for connecting cables.

WARNING

If necessary, use two people to lift or move the monitor.

Connect the cables to the system box.

Perform the following steps to connect cables and prepare the system box for use. The steps are keyed to the figures.

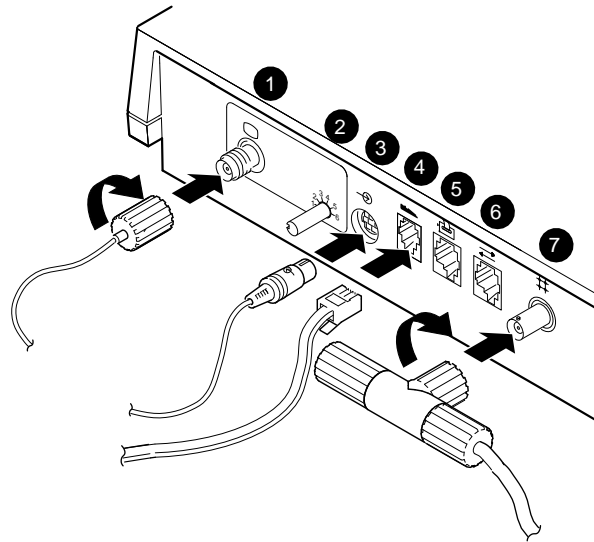

MA-0667-90.DG

- ❶ Connect one end of the monitor cable to the monitor and the other end to the system box.
If you have a VRE01 monitor, attach the cable-holding fixture to the rear of the monitor before connecting the cable.
- ❷ Set the monitor selection switch to match your monitor.

Monitor	Switch Position
VR315	5
VR319	2
VRE01	3

18 Installing Your Terminal

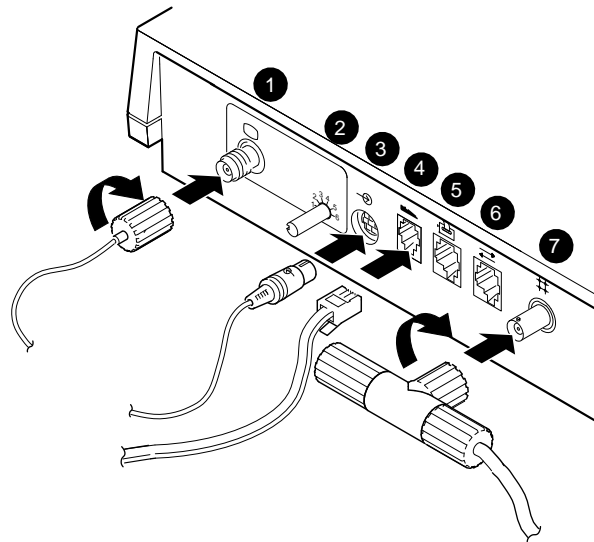

MA-0667-90.DG

- ③ Connect the mouse or graphics tablet to the system box.
- ④ Connect the keyboard to the system box. Lower the keyboard's legs and install the legend strip for the top-row keys.
- ⑤ Serial printer port: If you have a printer or secondary host computer, connect the printer or host to the system box.
- ⑥ Serial host port: If you have a primary host computer or terminal server, connect the host or server to the system box.
- ⑦ Connect the ThinWire Ethernet cable's T-connector to the system box. Connect the other end of the cable to your local area network.

Serial Baud Rate For serial communication, the terminal is initially set to a baud rate of 9600. Use the setting that matches your host system. To set the serial baud rate, see "Changing Your Host Port or Printer Port Settings" in Chapter 7.

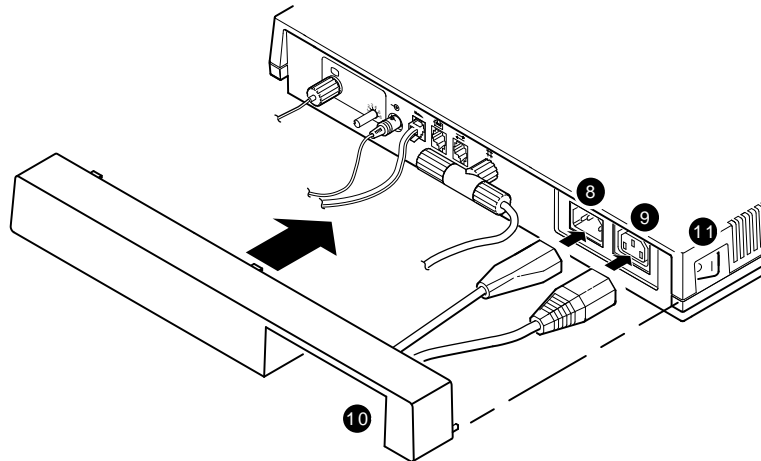

MA-0668-90.DG

- 8 Make sure the power switches on the system box and monitor are off (O). Then connect the long power cord to the system box and a grounded electrical outlet.
- 9 Connect the short power cord to the monitor and the system box.
- 10 Route all cables under the dress panel. Then push the dress panel onto the rear of the system box.
- 11 Turn the monitor's power switch on by pressing (I). Turn the system box's power switch on by pressing (I).

The keyboard sounds a bell tone, and a pie graph gradually fills in as the terminal performs its self-tests.

When the tests are done, the keyboard bell tone sounds again and the Terminal Manager window appears.

Final steps . . .

- If you had problems with the installation, review the installation steps carefully. If the problem continues, refer to Chapter 11.
- This is a good time to set the brightness, contrast, and viewing angle of your monitor. See your monitor's installation guide for instructions.
- If you installed optional RAM memory, use the procedure at the end of this chapter to verify that the system recognizes the additional memory.

Otherwise, the installation procedure is complete. You can go to Chapter 3 to begin using your terminal.

Installing Memory

This section describes how to install memory boards in the system box. You can install

- Additional random access memory (RAM)
- A new read-only memory (ROM) board containing updated firmware

The terminal comes with 2 megabytes of RAM memory. You can add 1 or 2 more megabytes of optional RAM memory, for a total of up to 4 megabytes.

Optional memory comes on 1-megabyte single in-line memory module (SIMM) cards. You install the SIMM cards on the RAM memory controller board.

Unpack and check the contents of the box.

- **If you are installing additional RAM memory**

You receive one or two SIMM cards.

- **If you are installing a ROM board**

You receive a ROM board.

Carefully inspect the components for shipping damage. If you have any missing or damaged items, contact your sales representative and delivery agent.

CAUTION

The memory boards and the SIMM cards can be damaged by electrostatic discharge. Handle the memory board by its cover or strap. Handle the SIMM card by the side edges of the card.

Remove the system box cover.

1. Use a grounding wrist strap and an antistatic mat to perform the installation, if available. Otherwise, frequently touch the metal chassis of the system box during installation, to neutralize any existing static charges.
2. Turn the system box's power switch off (O).
3. Turn the monitor's power switch off (O).
4. Disconnect the two power cords from the rear of the system box.
5. Disconnect the monitor video cable from the rear of the monitor.
6. Remove the monitor from the top of the system box. You may need two people.
7. Release the top cover of the system box by pressing in the two push tabs on the side of the box with the power switch, as shown.
8. Slowly lift the top cover until you release the hinges on the other side of the box. Then lift the top cover completely off the system box.

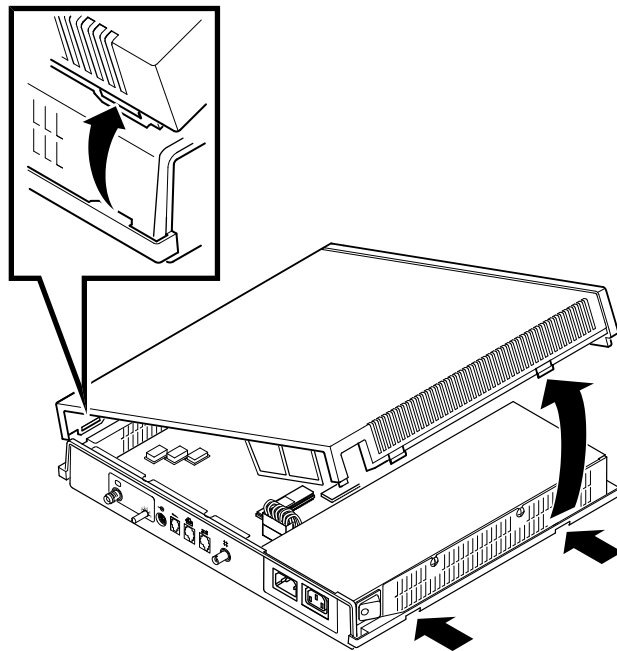

GSF_0839_89.DG

Identify the components in the system box.

There are four major components in the system box. The memory controller board is shown installed. SIMM cards install on the other side of the memory controller board.

If you are installing optional RAM memory, go to the next section.

If you are installing a ROM board, go to the section “Installing the ROM Board.”

System Box Components

- ① System logic board
- ② RAM memory controller board
- ③ ROM board
- ④ Power supply

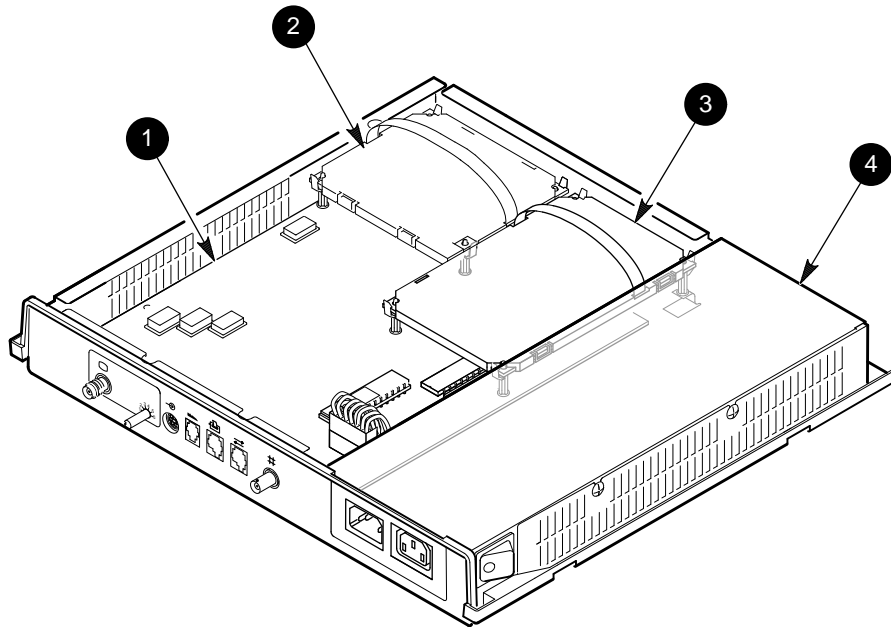

GSF_1362_89.DG

Installing RAM Memory

CAUTION

The memory controller board and the SIMM cards can be damaged by electrostatic discharge. Handle the memory controller board by its cover or strap. Avoid contact with any components or circuitry within the system box.

Remove the memory controller board.

1. Release the standoff clips by gently pushing each clip away from the board and lifting up on the edges of the board.
2. Grasp the strap of the memory controller board and pull up firmly to release the memory controller board connector from the system logic board.
3. Place the board on top of the power supply's metal cover, with the strap side down. This prevents electrostatic damage.

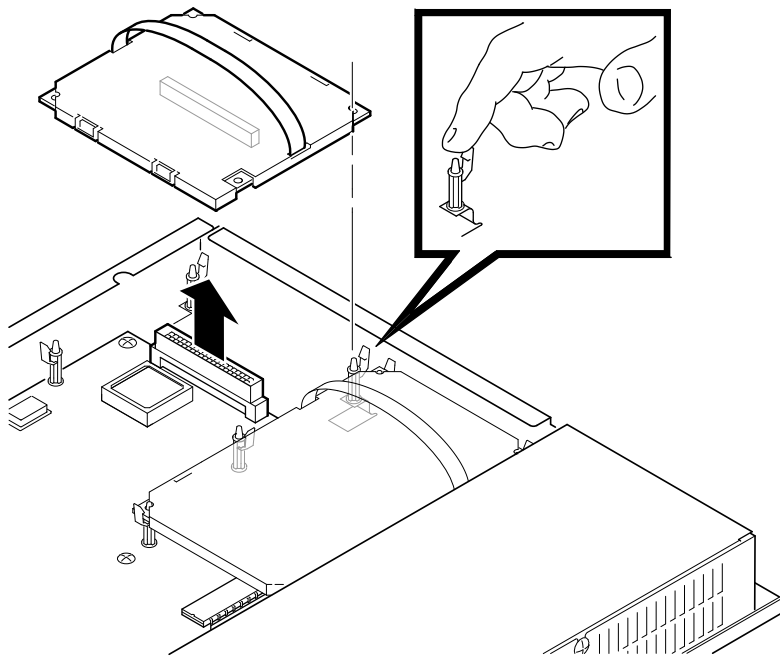

Install the SIMM cards on the memory controller board.

1. Remove the SIMM cards from the shipping bag.
2. Place the SIMM cards on top of the power supply's metal cover. Use the metal cover as a work surface to install the SIMM cards on the memory controller board. This prevents electrostatic damage.
3. The memory controller board already has one SIMM card installed in the connector labeled 2MB. Install the next SIMM card in the connector labeled 3MB and the last SIMM card in the connector labeled 4MB, as follows:

CAUTION

SIMM cards can be damaged by electrostatic discharge. Handle the SIMM card by the side edges of the card. Avoid contact with the gold contact fingers on the card.

- a. Insert the SIMM card into the connector at a 45-degree angle. Face the components on the SIMM card toward the components on the memory controller board. Line up the center key slot on the SIMM card with the connector key on the memory controller board.
- b. Push down on the top of the SIMM card to securely seat the card in the connector.
- c. Raise the SIMM card into a standup position, until both sides of the card lock into the connector tabs.

26 Installing Your Terminal

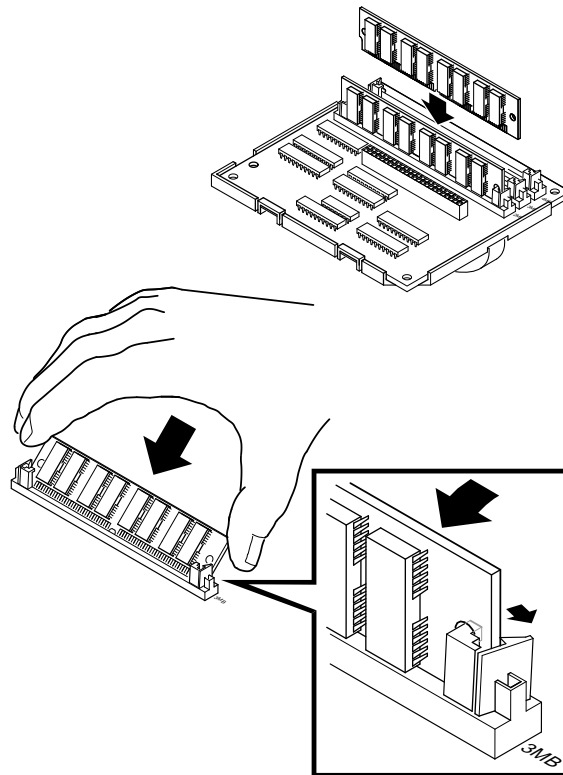

GSF_0840_89.DG

To remove the SIMM card: Gently push outward on the tabs at the sides of the connector. Tilt the SIMM card forward at a 45-degree angle, toward the edge of the RAM board. Grasp the edges of the SIMM card firmly and lift the card out of the connector.

Install the memory controller board into the system box.

1. Grasp the strap of the memory controller board.
2. Carefully place the board on top of its connector and standoffs in the system box. Use the standoffs as guides to align the connector on the board with the connector in the system box.
3. Press down firmly on the board and its edges to seat the connector and lock each of the four standoff clips.
4. Go to the section “Replace the system box cover.”

NOTE

If you have problems, recheck the installation procedures carefully. If the problem continues, contact Digital Customer Services.

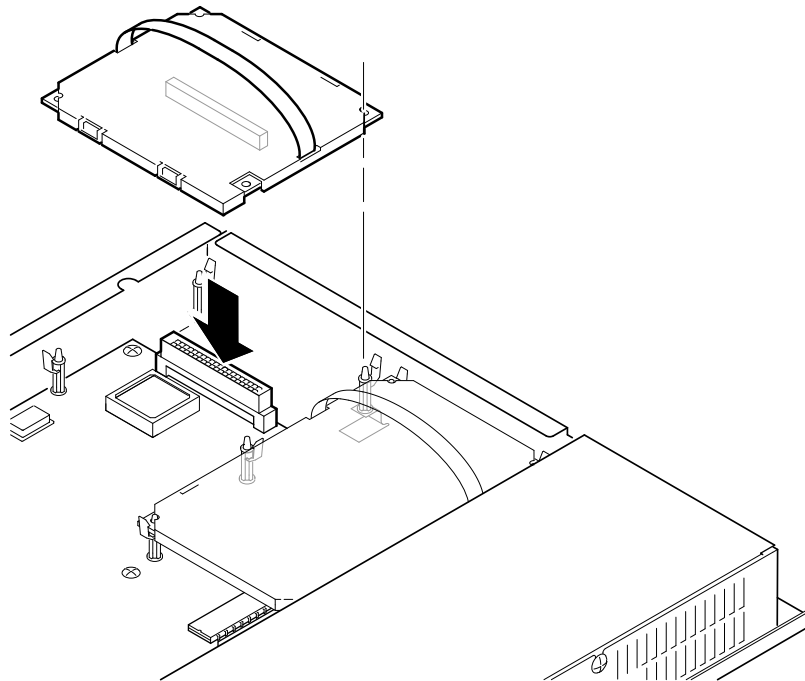

GSF_0842_89.DG

Installing the ROM Board

CAUTION

The ROM board can be damaged by electrostatic discharge. Handle the ROM board by its cover or strap. Also avoid contact with any components or circuitry in the system box.

Remove the old ROM board from your system box.

1. Release the standoff clips by gently pushing each clip away from the board and lifting up on the edges of the board.
2. Grasp the strap of the ROM board and pull up firmly to release the ROM board connector from the system logic board.

Set the old ROM board aside.

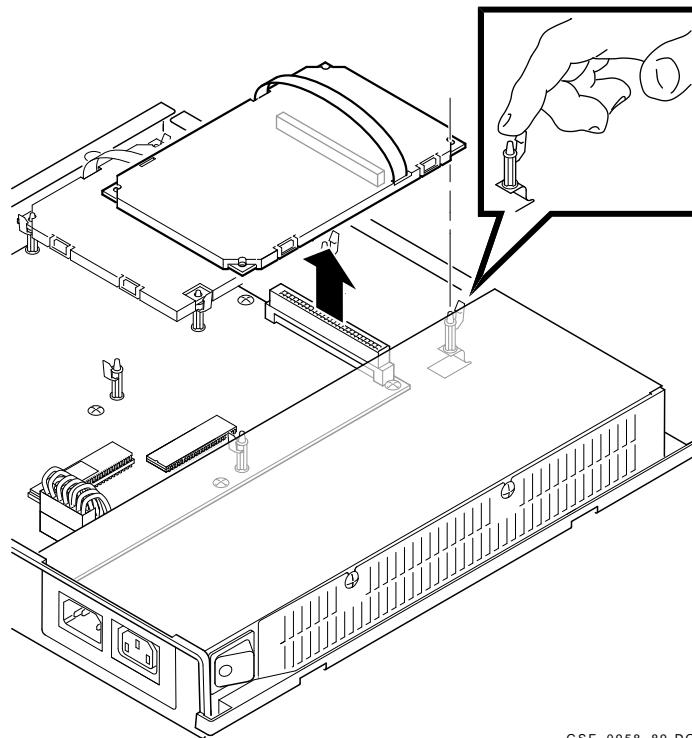

GSF_0958_89.DG

Install the new ROM board into the system box.

1. Remove the new ROM board from the box and shipping bag.
2. Grasp the strap of the new ROM board.
3. Carefully place the board on top of the ROM connector and standoffs in the system box. Use the standoffs as guides to align the connector on the board with the connector in the system box.
4. Press down firmly on the board and its edges to seat the connector and lock each of the four standoff clips.
5. Continue to the next section to replace the system box cover.

Replace the system box cover.

1. From the rear of the system box, place the left side of the top cover onto the hinge tabs in the left side of the system box.
2. Gently lower the right side of the top cover onto the system box. Make sure the power connector frame slides into the slot behind the power connectors.
3. Push down on the right side of the top cover until it snaps into the two push tabs, locking it in place.

After Installing the Memory Controller Board or ROM Board...

If you are installing the terminal, go back to the beginning of this chapter and continue the installation procedure.

If not, perform the following steps:

1. Place the monitor on top of the system box. Leave enough room to connect cables on the rear of the system box and monitor.
2. Connect the two power cords to the rear of the system box.
3. Connect the monitor video cable to the rear of monitor.
4. Turn on the system box's power switch by pressing (|).
5. Turn on the monitor's power switch by pressing (|).

Verifying the Installation of Optional RAM Memory

The Terminal Manager window should be displayed on your screen.

Verify that the number on the right side of the `Memory Remaining` scale displays the correct number of total megabytes in your system.

Standard	+	Optional	=	Number Displayed
2 megabytes		1 megabyte		3M
		2 megabytes		4M

NOTE

If you have problems, recheck the installation procedures carefully. If the problem continues, contact Digital Customer Services.

The installation procedure for optional memory is complete.

3

Getting Started

This chapter provides step-by-step procedures on how to begin using your terminal with a host computer. The chapter also introduces some of the terminal's screens and menus.

If you are unfamiliar with using windows and a mouse, you may want to read the information in Chapter 4 before continuing.

Before you start, you should set the terminal to use the desired display language and keyboard type. By default, the terminal uses the English language and the North American keyboard type.

You can use your terminal with the VMS, ULTRIX, or UNIX operating systems. You can open two types of sessions on these systems—a video terminal session or X window session.

The chapter includes sections on:

- Terminal Manager window
- Choosing the correct display language
- Choosing the correct keyboard type
- Opening a session on a VMS host system
- Opening a session on a UNIX or ULTRIX host system
- Ending a session