

**VT1000 / VT1200
and DECimage 1200
Service Guide**

Order Number EK-V1000-SV.002

Digital Equipment Corporation

First Edition, September 1990
Second Edition, April 1991

The information in this document is subject to change without notice and should not be construed as a commitment by Digital Equipment Corporation. Digital Equipment Corporation assumes no responsibility for any errors that may appear in this document.

The software described in this document is furnished under a license and may be used or copied only in accordance with the terms of such license.

No responsibility is assumed for the use or reliability of software on equipment that is not supplied by Digital Equipment Corporation or its affiliated companies.

Restricted Rights: Use, duplication, or disclosure by the U. S. Government is subject to restrictions as set forth in subparagraph (c) (1) (ii) of the Rights in Technical Data and Computer Software clause at DFARS 252.227-7013.

Copyright © Digital Equipment Corporation 1990, 1991

All Rights Reserved.
Printed in U.S.A.

The following are trademarks of Digital Equipment Corporation:

DEC, DECimage 1200, DECnet, DECterm, DECwindows, ThinWire, ULTRIX, VAX, VMS, VR150, VT, VT1000, VT1200, and the DIGITAL logo.

UNIX is a trademark of American Telephone and Telegraph Company.

This document was prepared and published by Educational Services Development and Publishing, Digital Equipment Corporation.

Contents

About This Guide	vii
1 Overview of the Terminal	
1.1 The Video Terminal's Components	2
1.1.1 System Box	3
1.1.2 Monitor	6
1.1.3 Keyboard	7
1.1.4 Mouse	7
1.2 Operating Features	7
1.2.1 X Window Sessions and Video Terminal Sessions	7
1.2.2 Network Communication Protocols	7
1.2.3 Customizing the Terminal	8
1.2.4 Overriding Passwords	8
1.3 Site Requirements	8
2 Testing	
2.1 Terminal Self-Tests	10
2.1.1 Successful Power-Up Self-Tests	11
2.1.2 Menu-Driven Diagnostic Tests	14
2.1.3 Displaying Video Alignment Patterns	20
2.2 Running Remote Diagnostic Tests over the Network (VMS Systems)	21
2.2.1 NCP Testing	22
2.2.2 LANSA Testing	26
2.3 Testing the LAT	29
2.4 Testing on ULTRIX and UNIX Systems	30
2.4.1 Testing TELNET	30
2.4.2 Using ping	33

3 Troubleshooting

3.1	Identifying the Terminal's Configuration	35
3.2	Troubleshooting by Flowchart	36
3.3	Troubleshooting by Error Code	38
3.3.1	Screen Error Messages	40
3.3.2	Reading LED Error Codes	42
3.4	Troubleshooting General Problems	44

4 Removing and Replacing FRUs

4.1	Cover	51
4.2	RAM Controller Board (VT1000 / VT1200 Only)	52
4.3	Image Board (DECimage 1200 Only)	53
4.4	SIMM Cards	54
4.5	ROM Board	56
4.6	System Logic Board	57
4.7	Power Supply	59
4.8	Fan	60
4.9	Keyboard, Mouse, and Printer	61

5 Starting a Session

5.1	Before You Start—Required Information	62
5.2	Starting a Session on a VMS System	63
5.3	Starting a Session on an ULTRIX or UNIX System	66
5.4	Ending a Session	68
5.5	Using Secure Reset	69
5.6	Displaying the Customize Image Dialog Box (DECimage 1200 Only)	71

A Related Documents

B Recommended Spares List

Figures

2-1	Terminal Manager Window	12
3-1	Terminal Troubleshooting Flowchart	37

Tables

2-1	Level 0 Tests	11
2-2	Level 1 Tests	13
2-3	Diagnostics Dialog Box Buttons	19
2-4	NCP Tests	23
2-5	<i>P3</i> Values to Specify Mode Bits	24
3-1	Troubleshooting by Error Code	38
3-2	Troubleshooting Error Code 13	39
3-3	Level 0 Screen Error Messages	40
3-4	Level 1 and Menu-Driven Screen Error Messages	41
3-5	LED Error Reporting Method	42
3-6	Troubleshooting the Terminal	44
A-1	Related Documents	73

About This Guide

This guide describes how to service the VT1000 video terminal, the VT1200 video terminal, and the DECimage 1200 video terminal. The guide uses the generic term *terminal* when describing information common to all three products.

Audience

The guide is for Digital's Customer Services Engineers and qualified self-maintenance customers.

Organization

The guide has five chapters that cover the following topics:

- Terminal overview
- Testing the terminal
- Troubleshooting the terminal
- Removing and replacing field replaceable units (FRUs)
- Starting a session on the terminal

Appendices provide information on the following topics:

- Modems, cables, and related documentation
- Recommended spares

Tools and Equipment

You need the following tools to service the terminal:

Tools and Equipment	Part Number
Phillips screwdriver, number 2	29-11005-00
Wrist strap and antistatic mat (included in Customer Services antistatic kit)	29-26246-00
Two 6-pin, DEC-423 loopback connectors (modular jack)	12-25083-01
Mouse loopback connector	12-25628-01
Two Ethernet terminators (H8225-00)	12-26318-01
ThinWire Ethernet T-connector (H8223-00)	12-25869-01
Tools required for VR150, VR262, VR315, VR319, and VRE01 monitors (See the service documentation for each monitor.)	

Conventions

The following conventions are used in this guide:

Convention	Meaning
terminal	Refers to the VT1000 terminal, the VT1200 terminal, and the DECimage 1200 terminal.
mouse	Refers to any pointing device, such as a mouse, a puck, or a stylus.
MB1, MB2, and MB3	MB1 indicates the left mouse button. MB2 indicates the middle mouse button. MB3 indicates the right mouse button. (The buttons can be redefined by the user.)
Keyboard key	Keys or switches that are labeled appear in a box . Example: Press the Return key.
Ctrl key	For Ctrl key sequences, hold down Ctrl and press the other key.
Cautions	Provide information to prevent damage to equipment or software.
Notes	Provide general information about the current topic.
PN	This is an abbreviation for <i>part number</i> .

1

Overview of the Terminal

This chapter provides an overview of the terminal's hardware and connectors, operating features, and site requirements.

You can use the terminal to:

- Connect to an Ethernet network through the terminal's ThinWire port.
- Connect directly to a computer through one of the terminal's two serial ports, like a traditional terminal.
- Display multiple video terminal (VTE) windows and applications over both the Ethernet and serial lines at the same time.
- Interact over an Ethernet network with multiple VTE window, DECwindows, and X window applications running under the VMS, ULTRIX, or UNIX operating system.
- Support the local area terminal (LAT) protocol for VMS systems and the transmission control protocol/Internet protocol (TCP/IP) for ULTRIX and UNIX systems.

NOTE

To identify the terminal's hardware configuration, see Section 3.1.

2 Overview of the Terminal

1.1 The Video Terminal's Components

The video terminal includes the following components:

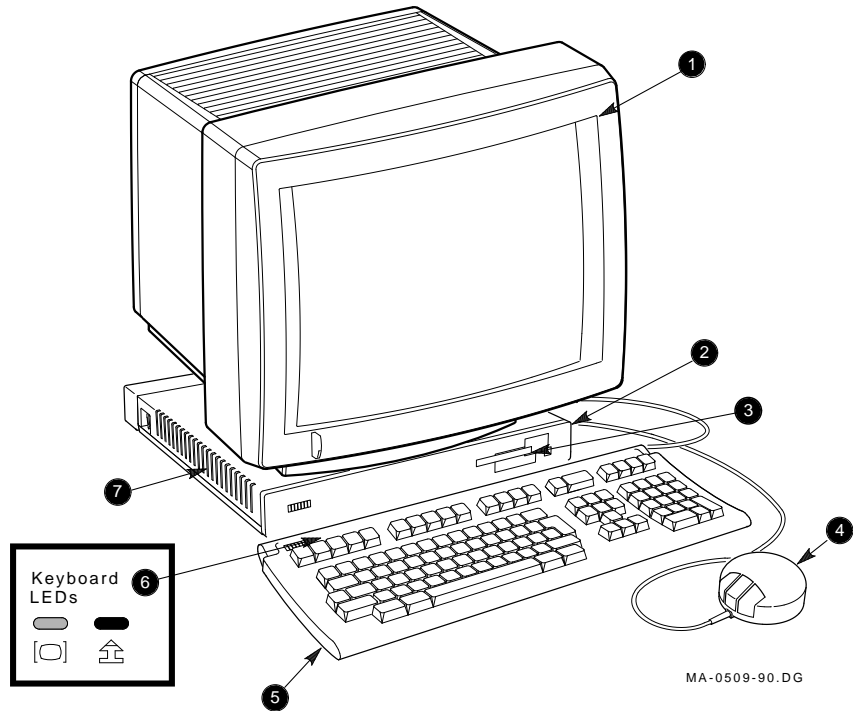

Item	Name	Description
①	Monitor	VR150, VR262, VR315, VR319, or VRE01 electroluminescent (EL) flat panel
②	System board LED	Red LED, visible through the ventilation slots on the side of the system box
③	Terminal logo	VT1000, VT1200, or DECimage 1200
④	Mouse	—
⑤	Keyboard	LK400 series
⑥	Keyboard LEDs	Hold and lock indicators
⑦	Power supply LED	Green LED, visible through the ventilation slots on the side of the system box

1.1.1 System Box

The system box provides the connectors for power, system communication, the keyboard, monitor, mouse, and a serial printer. The system box is 368 mm (14.5 in.) deep × 394 mm (15.5 in.) wide × 57 mm (2.25 in.) high. A cover panel attaches to the rear of the system box to conceal the connectors and cables.

VT1000 and VT1200 System Box FRUs

The system box contains the following field replaceable units (FRUs). Part numbers follow each FRU. Appendix B lists all part numbers.

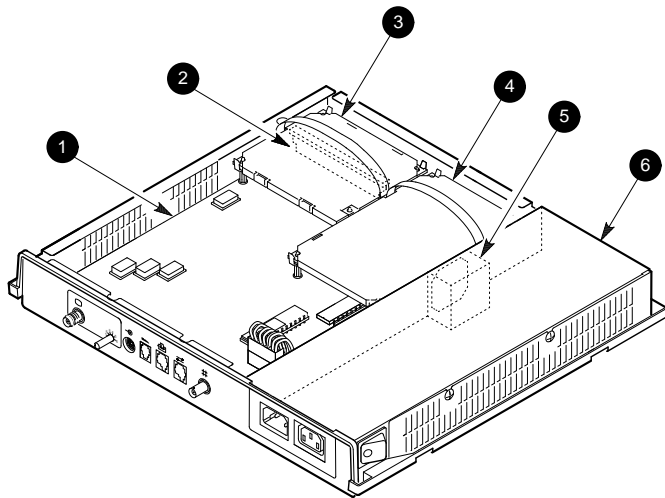

GSF_1362_89A.DG

①	System logic board	54-19783-01
②	SIMM card (installed on the other side of the RAM controller board)	VX10X-MD
③	RAM controller board (optional in VT1000)	54-19807-01
④	ROM memory board (VT1000/VT1200)	54-19803-01 (VX10A)
⑤	Fan	70-26582-01
⑥	Power supply	H7109-A

4 Overview of the Terminal

DECimage 1200 System Box FRUs

The DECimage 1200 system box contains the following field replaceable units (FRUs). Part numbers follow each FRU. Appendix B lists all part numbers.

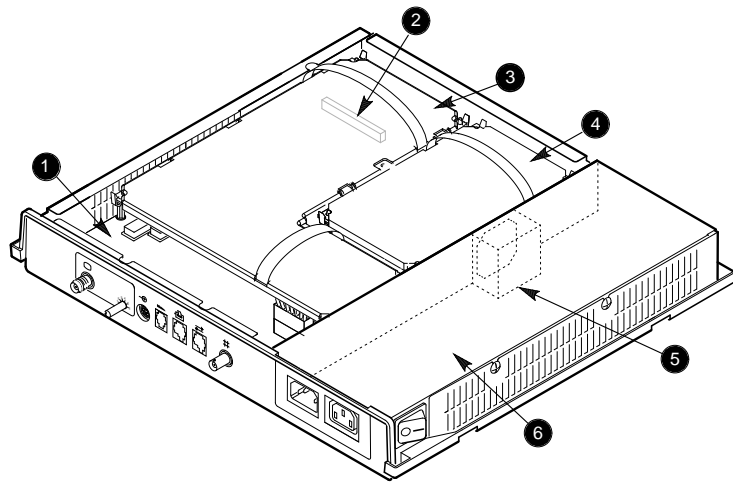

MA-0510-90.DG

①	System logic board	54-19783-01
②	SIMM card (installed on the other side of the image board)	VX10X-MD
③	Image board assembly	70-27988-02
④	ROM memory board (DECimage 1200)	54-19803-03 (VX11A)
⑤	Fan	70-26582-01
⑥	Power supply	H7109-A

Memory

The terminal has a memory capacity of 4 megabytes. The base system has 2 megabytes of RAM memory—1 megabyte of RAM on the system logic board and a 1-megabyte SIMM card on the controller board (a RAM controller board or image board).

SIMM stands for single in-line memory module. The controller board has slots for three 1-megabyte SIMM cards.

System Box Connectors and Switches

The following figure shows the connector panel on the rear of the system box:

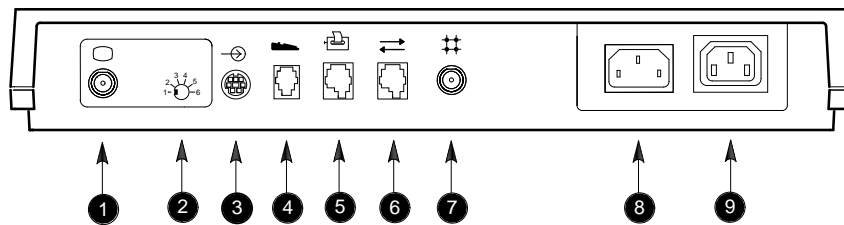

GSF_0824_89.DG

- | | | |
|----------------------------|-----------------------|-----------------------|
| ① Monitor | ④ Keyboard | ⑦ ThinWire Ethernet |
| ② Monitor selection switch | ⑤ Serial printer port | ⑧ System box ac power |
| ③ Mouse/pointing device | ⑥ Serial host port | ⑨ Monitor ac power |

6 Overview of the Terminal

1.1.2 Monitor

The terminal uses either a monochrome monitor (VR150, VR262, VR315, or VR319) or a VRE01 EL flat-panel display. For more information, see the service guide for each unit (Appendix B).

Monitor Selection Switch

Before power-up, make sure the monitor selection switch on the rear of the system box is set to match the monitor. To find the monitor's model number, check the labels on the rear of the monitor.

NOTE

The terminal searches for the monitor selection switch position only during the power-up sequence.

Monitor	Position	Screen Size	Resolution
VR150 CRT	1	383 mm (15 inch)	100 dots/inch
VR319 CRT	2	482 mm (19 inch)	100 dots/inch
VR262 CRT	3	482 mm (19 inch)	75 dots/inch
VRE01 flat panel	3	482 mm (19 inch)	75 dots/inch
VR315 CRT	5	383 mm (15 inch)	100 dots/inch

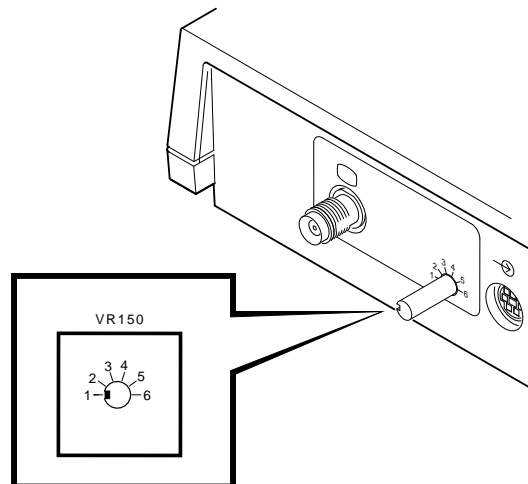

LJ-00059-T10

1.1.3 Keyboard

The terminal uses the LK400 series keyboard. It has four groups of keys, two LED indicators, and two audible indicators—a keyclick and bell. The LK401-XX is the standard version, and the LK402-XX is the word processing version.

1.1.4 Mouse

The mouse is a three-button pointing device. The mouse lets you choose items from screen menus or move the cursor to different points on the screen.

1.2 Operating Features

This section briefly describes terminal sessions, network protocols, and how to control feature settings on the terminal.

1.2.1 X Window Sessions and Video Terminal Sessions

The terminal lets you open two types of sessions on host computers:

Video Terminal Session

The terminal has a video terminal (VTE) window that lets you log into a host as you would on a conventional video terminal. The terminal's VTE window works like Digital's VT320 terminal.

X Window Session

The terminal lets you open X window sessions. To run an X window session, you log into a host and use that host's X window software.

You can open one X window session and several VTE sessions at the same time. Within the X window session, you can run multiple X window clients. Each X window client and VTE session appears in a separate window.

1.2.2 Network Communication Protocols

You can use the terminal with the VMS, ULTRIX, or UNIX operating systems. You can run video terminal sessions and X window sessions on any of these operating systems.

For VMS systems: The local area transport (LAT) protocol is the communication protocol.

8 Overview of the Terminal

For ULTRIX and UNIX systems: The transmission control protocol/Internet protocol (TCP/IP) is the communication protocol. The terminal can use the TCP/IP TELNET or LAT communication protocols to make video terminal connections to UNIX and ULTRIX-based host systems in a wide-area network.

1.2.3 Customizing the Terminal

The terminal has a Terminal Manager window with a Customize menu that lets users view and change the settings of the terminal's operating features. The terminal stores feature settings in nonvolatile RAM (NVR) memory. NVR retains the settings when the terminal is turned off, so the terminal can restore the settings when power is turned on again. The terminal can also restore factory-default settings from program memory (ROM).

Before you start a session, make sure you have the font path, group code, and specific addresses in use (Section 5.1).

1.2.4 Overriding Passwords

Performing a **Secure Reset** allows you to override saved passwords. You may need to perform a secure reset if a user locks the terminal's customize dialog boxes, then forgets the customize security password.

When you perform a secure reset from the Session pull-down menu, the terminal resets all customized settings to their factory defaults, except the **Secure Reset Count**.

Each time you perform a secure reset, the secure reset count in the Terminal Manager window increases by one.

To perform a secure reset, see Section 5.5.

1.3 Site Requirements

The terminal requires certain system software and network hardware to operate. The system manager must ensure these requirements are met. An appendix in the terminal's *Installing and Using . . .* guide describes the required system management tasks for the terminal.

Network Hardware Support

The terminal requires one of the following physical connections to connect to a host computer system:

ThinWire connector Lets the terminal operate with X window applications and multiple video terminal (VTE) sessions, using either the LAT or TCP/IP network protocol. You must use the ThinWire connector to operate with X window or DECwindows software.

Serial line Lets the terminal connect to a single host or terminal server as a traditional video terminal.

System Software Support

The following table summarizes the system resources needed to open X window sessions or video terminal (VTE) sessions:

Operation	Operating System	Communication Protocol
Video terminal session	VMS Version 4.0 or higher	LAT
	UNIX (any version)	TELNET (TCP/IP)
	ULTRIX (any version) UWS Version 2.2	TELNET (TCP/IP) or LAT
X window session	VMS Version 5.3-1 or higher	LAT
	UNIX (any version)	TCP/IP TFTP (UDP) for font service
	UWS Version 2.1 or higher (includes ULTRIX Version 3.1)	TCP/IP TFTP (UDP) for font service

2

Testing

This chapter describes how to:

- Run the terminal's built-in self-tests and menu-driven diagnostic tests.
- Display video alignment patterns on the monitor.
- Run remote diagnostic tests on the terminal over the network.
- Test the LAT.
- Test TELNET and network hardware on UNIX and ULTRIX systems.

To test the monitor, see the monitor's service guide.

2.1 Terminal Self-Tests

The terminal has a series of self-tests to help you isolate failures to faulty field replaceable units (FRUs). You can run self-tests in three ways.

- Automatically during power-up
- Using menu-driven diagnostics
- Using remote diagnostics on the network

The terminal automatically performs basic self-tests during power-up. You can run more extensive self-tests by using the terminal's Diagnostics dialog box and connecting loopback connectors to specific ports. Remote diagnostics let you test the terminal from a remote host.

NOTE

Running the menu-driven diagnostic tests resets the terminal and quits all session activity.

If a test finds an error:

1. Record the error code.
2. Find the error code and suggested solution in Table 3–1.
3. Repeat the tests in this chapter to ensure the terminal operates correctly.

The terminal will not service any interrupts or commands, except as necessary to perform testing.

2.1.1 Successful Power-Up Self-Tests

Power-up self-tests run each time you turn on the power switch on the system box. There are two levels of power-up self-tests —level 0 and level 1. Level 0 tests run first, followed by level 1 tests. Failure of some power-up tests may prevent the terminals from running.

Level 0 Testing

When you turn on the terminal, level 0 testing begins. When level 0 testing completes successfully (within 5 seconds), the operating system starts and level 1 testing begins automatically.

Table 2–1 lists the eight level 0 tests.

Table 2–1 Level 0 Tests

Simple CPU test	Video control register test
ROM checksum test	I/O data path test
RAM test	Illegal monitor test
Interrupt test	Ethernet port (LANC) not reset on power-up test

Level 1 Testing

Level 1 testing begins by displaying various patterns on the screen.

Next, a pie graph display appears to indicate the progress of level 1 testing. As each test finishes, a segment of the pie fills in.

When level 1 testing completes successfully (within 25 seconds of power-up):

- The keyboard bell rings.
- The keyboard LEDs turn off.

12 Testing

- The system logic board LED turns off.
- The pie graph is replaced by the Terminal Manager window (Figure 2–1). The Terminal Manager title bar displayed on your terminal indicates the software version running.
- The diagnostic summary box in the window contains the message:

All Diagnostics Passed

MA-0813-90.RAGS

Figure 2–1 Terminal Manager Window

Table 2-2 lists the 15 level 1 tests.

Table 2-2 Level 1 Tests

Video RAM test	DUART1 timer test
Video test	Keyboard port test
NVR checksum test	Mouse port test
Ethernet address ROM test	DUART2 timer test
Option RAM test (if present)	Ethernet port (LANCE) test
Host port test	Mouse test
Printer port test	Keyboard test
Image test (if installed)	

System Logic Board LED Power-Up Sequence

When the terminal powers up, the red LED on the system logic board turns on. At the start of level 0 testing, the LED turns off. If level 0 completes successfully, the LED turns on again. The operating system then performs level 1 testing. If level 1 testing is successful, the LED turns off. The following diagram shows the complete sequence:

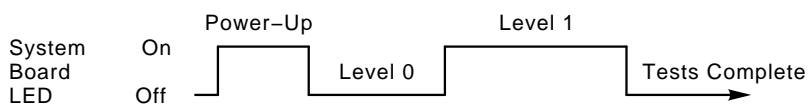

2.1.2 Menu-Driven Diagnostic Tests

Menu-driven diagnostic self-tests let you test each device again after the power-up self-tests are complete. You can test devices individually, a few at a time, or all together in sequence. Use menu-driven diagnostics to:

- Perform external loopback testing.
- Verify the terminal's operation after making repairs.

CAUTION

Menu-driven diagnostics cancel current host connections, cause a software reset, and write messages on the screen.

Loopback Connectors

The loopback test can check the driver and receiver hardware of the following ports on the rear of the system box:

Port	Loopback Connector	Part Number
Host port	6-pin loopback connector, MMJ (H3103-00)	12-25083-01
Printer port	6-pin loopback connector, MMJ (H3103-00)	12-25083-01
Mouse port	Mouse loopback connector	12-25628-01
Ethernet port	Ethernet T-connector (H8223-00)	12-25869-01
	with terminators (H8225-00)	12-26318-01

The following figure shows the loopback connectors. Install the appropriate connector on each port you want to test.

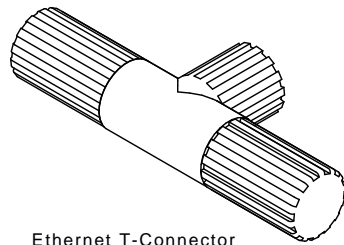
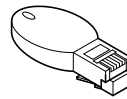
Ethernet T-Connector
with Terminators

6-Pin Loopback Connector

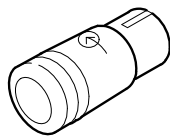

Mouse Loopback Connector

From Pin	To Pin
1	6
2	5
3	4

MA-0511-90.DG

To run menu-driven diagnostics:

The terminal must complete the power-up self-tests and display the Terminal Manager window. You run menu-driven diagnostic tests from the terminal's Diagnostics dialog box. Use the following procedure to display the Diagnostics dialog box and choose tests:

NOTE

Running the menu-driven diagnostic tests resets the terminal and quits all session activity.

1. Turn on the terminal. After the power-up self-tests are complete, the Terminal Manager window appears.
2. Press and hold down the **[Shift]** and **[Ctrl]** keys on the keyboard.
3. With your other hand, move the mouse until the pointer is on the **Session** menu name in the Terminal Manager's menu bar.
4. Click and hold the left mouse button, known as mouse button 1 (MB1). The Session pull-down menu appears.

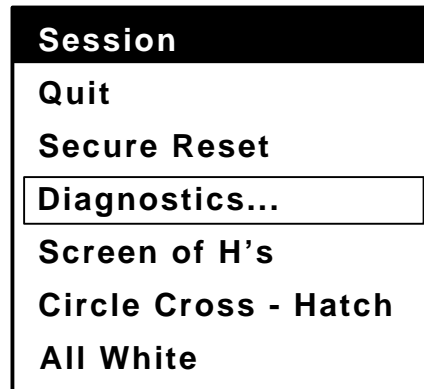

MA-0762-90.DG

NOTE

If the user has chosen the left-handed settings for the mouse, MB1 is the button on the right.

5. Release the **Shift** and **Ctrl** keys.
6. Move the mouse pointer down to the **Diagnostics . . .** menu item.
7. Release MB1. The Diagnostics dialog box appears.

NOTE

The Image Hardware Test is only listed in the dialog box for a DECimage 1200 terminal.

18 Testing

8. From the Diagnostics dialog box, choose the devices to test. Table 2-3 describes all the choices.

To run . . .	Do this . . .
One or more individual tests	Move the pointer to the button next to the desired test. Click on MB1. To start the tests, click on the Run Selected Tests button or press [Return] .
All tests	Click on the Run All Tests button.
Loopback tests	At the rear of the system box, install loopback connectors on the ports you want to test. Click on the Perform External Loopback on Port Tests button. Click on either the Run Selected Tests button or Run All Tests button.

If the test(s) run successfully:

The following message appears in the diagnostic messages box at the bottom of the screen:

All Diagnostics Passed

If an error occurs:

The keyboard bell does not ring at the end of testing. The diagnostic displays error codes in three places:

- In the diagnostic summary box
- On the keyboard LEDs (one time, not repeatedly)
- On the system logic board LED (one time, not repeatedly)

To troubleshoot the error:

1. Record the error code.
2. Find the error code and suggested solution in Table 3-1.

3. Repeat the tests in this chapter to ensure the terminal operates correctly.

Table 2-3 Diagnostics Dialog Box Buttons

Button	Function
ROM Checksum Test	Verifies the checksum of the program ROM.
NVR Checksum Test	Verifies the checksum of the NVR.
Ethernet Address ROM Test	Verifies the format and checksum of the Ethernet address ROM.
RAM Test	Verifies the RAM data and address paths.
Video RAM Test	Verifies the video RAM data and address paths.
Video Test	Verifies the horizontal and vertical synchronization, video path, and attributes logic by displaying a specific pattern.
Keyboard Test	Firmware requests that the keyboard do its self-test and display any error code.
Mouse Test	Firmware requests that the mouse or tablet do its self-test and display any error code.
Image Hardware Test	Firmware verifies the image board functions. The image board and the image ROM board must be installed to run this test.
Host Port Test	Verifies the internal data paths of the host port's universal asynchronous receiver transmitter (UART) by using its local loopback mode. If you also choose the external loopback test, this test checks the driver and receiver hardware as well.
Printer Port Test	Verifies the internal data path of the printer port UART by using its local loopback mode. If you also choose the external loopback test, this test checks the driver and receiver hardware as well.
Ethernet Port Test	Verifies the internal data path of the Ethernet chip set by using its local loopback mode. If you also choose the external loopback test, this test checks the driver and receiver hardware as well.
Keyboard Port Test	Verifies the internal data paths of the keyboard UART by using its local loopback mode. There is no external loopback test for the keyboard port.

Table 2–3 (Cont.) Diagnostics Dialog Box Buttons

Button	Function
Mouse Port Test	Verifies the internal data paths of the mouse UART by using its local loopback mode. If you also choose the external loopback test, this test checks the driver and receiver hardware as well.
Perform External Loopback on Port Tests	Allows diagnostics to run external loopback tests on the host, printer, Ethernet, and mouse ports.
Forever Loop On Tests	Repeats the chosen test(s) until an error is detected or you turn off the terminal.
Run Selected Tests	Runs the chosen tests. You can also press Return to perform the same function.
Run All Tests	Runs all tests once, with or without external loopbacks.

2.1.3 Displaying Video Alignment Patterns

The terminal can display the following video alignment patterns for adjusting the monitor display:

Screen of H's	Fills the entire active area with uppercase letter H's (to adjust focus).
Circle Cross-hatch	Fills the screen with a crosshatch pattern and draws a large circle in the middle (to show linearity and aspect ratio).
All White	Displays the entire active area as white or positive video (for adjusting the active area).

To choose the patterns:

Display the Session menu from the Terminal Manager window.

1. Turn on the terminal. The Terminal Manager window appears.
2. Press and hold down the **Shift** and **Ctrl** keys on the keyboard.
3. With your other hand, move the mouse until the pointer is on the **Session** menu name in the Terminal Manager's menu bar.

4. Click and hold the left mouse button, known as mouse button 1 (MB1). The Session pull-down menu appears.

NOTE

If the user has chosen the left-handed settings for the mouse, MB1 is the button on the right.

5. Release the **[Shift]** and **[Ctrl]** keys.
6. Move the mouse pointer down to the name of the desired pattern.
7. Release MB1. The chosen pattern appears.
8. Press any key on the keyboard to refresh the screen.

2.2 Running Remote Diagnostic Tests over the Network (VMS Systems)

The terminals have built-in support for the Ethernet maintenance operations protocol (MOP). You can test the terminal remotely from any host system that supports the MOP version 3.0 console carrier protocol. VMS host software that implements the console carrier protocol includes

- Network control protocol (NCP)
- Local area network service application (LANSA)

The following sections describe how to test the terminal with NCP and LANSA.

You use MOP to:

- Verify the terminal's connection to the network.
- Verify that the terminal can communicate with other nodes.
- Test the terminal from a remote console and display an error message with error code.

Remote Test Requirements

Reset the terminal by turning the power off and on, or by selecting **Quit** from the Session pull-down menu. Make sure that:

- The power switch on the system box is on.
- The terminal is connected to the same Ethernet network as the remote console.

22 Testing

- The terminal does not have any active work (no open windows).

2.2.1 NCP Testing

To run diagnostics on the terminal from a remote console, use the network control protocol (NCP) as follows:

1. Enable NCP by entering one of the following commands:

```
$ MCR NCP
```

or

```
$ RUN SYS$SYSTEM:NCP
```

The NCP> prompt appears.

2. Make a logical connection between the remote console and the terminal, using the CONNECT VIA command. The command format is

```
CONNECT VIA circuit-id PHYSICAL ADDRESS terminal's_Ethernet_address
```

For example:

```
NCP> CONNECT VIA bna-0 PHYSICAL ADDRESS 08-00-00-34-00-7D
```

To determine the *circuit-id*, use the following command:

```
NCP> SHOW KNOWN CIRCUIT
```

To determine the *terminal's Ethernet_address*, ask the user to read it from the Terminal Manager window.

When you successfully connect to the terminal, the following message appears:

```
Console connected (press CTRL/D when finished)
```

3. Press the Return key to display the following prompt:

```
DWT>>>
```

DWT stands for DECwindows terminal (VT1000, VT1200, or DECimage 1200).

4. Enter HELP to display the commands available.

DWT>>>HELP

DECwindows Terminal Remote Console

Commands available:

```
-----
INIT          Initialize the system.
SHOW          Show the terminal's system configuration.
TEST <P1> [<P2> <P3>] Execute test(s) p1 through p2.
               Mode bits are specified by p3.
HELP          Type this help text.
```

5. Enter a TEST command. The TEST command accepts three parameters.

- P1* Specifies the test to run, 0–19 (Table 2–4).
- P2* Used with *P1* to specify a range of tests (*P1*–*P2*).
- P3* Specifies one or more mode bits to control execution of the self-test modules (Table 2–5).

Table 2–4 NCP Tests

Test Number	Description
0	ROM checksum test
1	NVR checksum test
2	Video RAM test
3	Main memory test
4	Host port test
5	Printer port test
6	DUART 2 channel A
7	Mouse port test
8	Keyboard test
9	Ethernet port test
10	Mouse test
11	Video test
12	Ethernet ROM checksum test
13	DUART timer1 test
14	DUART timer2 test
15	Optional RAM SIMM 1 test
16	Optional RAM SIMM 2 test
17	Optional RAM SIMM 3 test
18	Video oscillator test
19	Image hardware test

Table 2-5 P3 Values to Specify Mode Bits

Bit Position	P3 Value	Description
0	1	External loopback: host port.
1	2	External loopback: printer port.
2	4	External loopback: mouse port.
3	8	LANCE loopback: Ethernet port.
4	16	Test all baud rates.
5	32	Do not exercise modem control signals.

Examples**NOTE**

NCP may time out while waiting for the terminal to perform self-tests. The timeout period of NCP version Phase V is adjustable.

- To run test number 5 with mode bits 4 and 1 specified:
 - Calculate the *P3* value to specify mode bits 4 and 1.

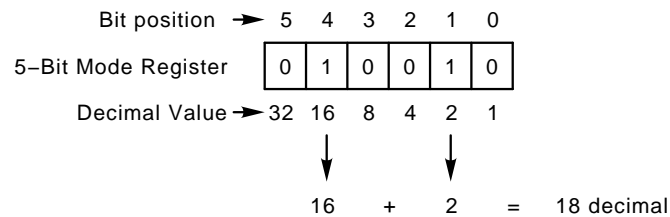

- Enter the command:

```
DWT>>> TEST 5 5 18
```

- To run all tests without mode bits:

```
DWT>>> TEST 0 18
```
- To run a single test (for example, test 16):

```
DWT>>> TEST 16
```

If the test is successful:

The terminal displays an OK message.

```
Testing...
OK
DWT>>>
```

If an error occurs:

The application displays an error message. To troubleshoot the error:

1. Record the error code.
2. Find the error code and suggested solution in Table 3-1.
3. Repeat the tests in this chapter to ensure the terminal operates correctly.

In the following example, the error code is 13.

```
Testing...
Test 16 Failed
Optional RAM Simm 2 Error - 13

DIAGNOSTIC MAILBOX:
-----
test_type:  00FFFF8E
test_mode:  00000000
test_result: 00000008
error_ext0: 00000000
error_ext1: 00000008
error_ext2: 00000000
error_ext3: 3F000000
error_ext4: 3F1FFFF0
error_ext5: 00000000
error_ext6: 00000000
diag_hld:   00FDFE8E
memory_bss: 0021F2D0
test_cnt:   00000001
test_f_cnt: 00000001
memory_lth: 00000000
video_dydx: 03600400
num_of_lnks: 00000000

DWT>>>
```

To exit NCP:

Enter the following command:

```
DWT>>>  
```

2.2.2 LANSA Testing

To run remote diagnostics on the terminal using the local area network service application (LANSA):

- Enable LANSA.
- Use the LANSA menus to select and run the tests.

NOTE

Before running LANSA, make sure it is available and supported on your system.

To enable LANSA, enter the following command:

```
$ RUN LANSA
```

LANSA displays a series of menus. The following example shows how to reach the test menu. In the example, the terminal to be tested is on a node named Mamal.

```
1. node status
2. select node
3. modify database
4. exit
                                CHOICE: 2
Next screen
1. exit
2. Chris
3. Mamal
4. Elisa
5. Jim
6. Orrin
                                CHOICE: 3
Next screen
                                Functions available for Mamal
1. sysid request
2. counter request
3. privileged functions
4. loop
5. display tests
6. exit
```

CHOICE: 3
Enter Password

Next screen

Select privileged function for Mamal

1. invoke test
2. show configuration
3. remote console
4. boot
5. exit

CHOICE: 1

Next screen

Available privileged tests for Mamal

1. T 0 ROM checksum test
2. T 1 NVR checksum test
3. T 2 Video RAM test
4. T 3 Main memory test
5. T 4 Host port test
6. T 5 Printer port test
7. T 6 DUART 2 channel a
8. T 7 Mouse port test
9. T 8 Keyboard test
10. T 9 Ethernet port test
11. T 10 Mouse test
12. T 11 Video Test
13. T 12 Ethernet ROM checksum test
14. T 13 DUART timer1 test
15. T 14 DUART timer2 test
16. T 15 Optional RAM Simm 1 test
17. T 16 Optional RAM Simm 2 test
18. T 17 Optional RAM Simm 3 test
19. T 18 Video oscillator test
20. T 19 Image test

CHOICE: 19

PERFORMING TEST, PLEASE WAIT....

If the test is successful:

The application displays an OK message.

Testing...
OK
DWT>>>

28 Testing

If an error occurs:

The application displays the error message. To troubleshoot the error:

1. Record the error code.
2. Find the error code and suggested solution in Table 3-1.
3. Repeat the tests in this chapter to ensure the terminal operates correctly.

In the following example, the error code is 13.

```
Testing...
Test 16 Failed
Optional RAM Simm 2 Error - 13
```

```
    DIAGNOSTIC MAILBOX:
    -----
test_type:  00200000
test_mode:  00000000
test_result: 00200000
error_ext0: 00800000
error_ext1: 55555555
error_ext2: 55555555
error_ext3: 00000019
error_ext4: 00000000
error_ext5: 000000FE
error_ext6: 00000000
diag_hld:   00200000
memory_bss: 0021F2D0
test_cnt:   00000001
test_f_cnt: 00000001
memory_lth: 00000000
video_dydx: 03600400
num_of_lnks: 00000000
```

2.3 Testing the LAT

The LATCP utility allows you to control and obtain information from the LAT port driver (LTDRIVER). Using the LATCP, you can do the following:

- Start and stop the LAT port driver.
- Specify configuration characteristics for your service node and its services.
- Modify and display configuration characteristics.
- Show system counters on the host computer.

To enable LATCP on a VMS system, enter one of the following commands:

```
$ MCR LATCP
```

or

```
$ RUN SYS$SYSTEM:LATCP
```

The application displays the LCP> prompt.

Examples

- The following command shows the server characteristics for two terminals:

```
LCP> SHOW SERVER
```

```
LCP Server Characteristics for LAT_08002B12D6FD
```

```
Ethernet address = 08-00-2B-12-D6-FD  
Server is active           Active users = 1  
Link name = LAT$LINK
```

```
LCP Server Characteristics for LAT_08002B11D26E
```

```
Ethernet address = 08-00-2B-11-D2-6E  
Server is active           Active users = 4  
Link name = LAT$LINK
```

- The following command shows the port characteristics for a node named TRACKS:

30 Testing

```
LCP> SHOW PORT

Local Port Name = LTA1:    (interactive)
Specified Remote Service Name = TRACKS
Actual Remote Node Name = LAT_08002B11D26E
Link Name = LAT$LINK

Local Port Name = LTA6:    (interactive)
Specified Remote Service Name = TRACKS
Actual Remote Node Name = LAT_08002B11D26E
Link Name = LAT$LINK

Local Port Name = LTA7:    (interactive)
Specified Remote Service Name = TRACKS
Actual Remote Node Name = LAT_08002B11D26E
Link Name = LAT$LINK

Port Name = LTA11:    (application)
Specified Remote Node Name = LAT_08002B11D26E
Specified Remote Service Name = X$SERVER
Actual Remote Node Name = LAT_08002B11D26E
Link Name = LAT$LINK

Local Port Name = LTA12:    (application)
Specified Remote Node Name = LAT_08002B11D26E
Specified Remote Service Name = X$SERVER
Actual Remote Node Name = LAT_08002B11D26E
Link Name = LAT$LINK

LCP>
```

2.4 Testing on ULTRIX and UNIX Systems

The following sections describe methods for testing the status of TELNET and network hardware.

2.4.1 Testing TELNET

To test TELNET, you can start a session on a TELNET terminal window and enter the host name **VT0STAT** or **VT0STATS**.

- If you enter **VT0STAT**, the terminal verifies that TCP is up and running. The following message should appear in the Terminal Manager window:

```
TCP is up and running
```

- If you enter VT0STATS, a VTE window displays the following information:

```
TCP STATS:
  0 connections initiated
  1 connections accepted
  1 connections established
  0 connections dropped
  0 embryonic connections dropped
  0 conn. closed (includes drops)
  3 segs where we tried to get rtt
  2 times we succeeded
  1 delayed acks sent
  0 conn. dropped in rxmt timeout
  0 retransmit timeouts
  0 persist timeouts
  0 keepalive timeouts
  0 keepalive probes sent
  0 connections dropped in keepalive
  4 total packets sent
  3 data packets sent
 634 data bytes sent
  0 data packets retransmitted
  0 data bytes retransmitted
  2 ack-only packets sent
  0 window probes sent
  0 packets sent with URG only
  0 window update-only packets sent
  0 control (SYN|FIN|RST) packets sent
  5 total packets received
  1 packets received in sequence
  4 bytes received in sequence
  0 packets received with ccksum errs
  0 packets received with bad offset
  0 packets received too short
  0 duplicate-only packets received
  0 duplicate-only bytes received
  0 packets with some duplicate data
  0 dup. bytes in part-dup. packets
  0 out-of-order packets received
  0 out-of-order bytes received
  0 packets with data after window
  0 bytes rcvd after window
  0 packets rcvd after close
  0 rcvd window probe packets
  0 rcvd duplicate acks
  0 rcvd acks for unsend data
  4 rcvd ack packets
 659 bytes acked by rcvd acks
  0 rcvd window update packets

UDP STATS:
  0 incomplete headers
  0 bad data length fields
  0 bad checksums
```

32 Testing

```
IP STATS:
 16000 total packets received
    0 bad header checksums
    0 smaller than minimum size
    0 data size < data length
    0 header length < data size
    0 data length < header length
    0 fragments received
    0 fragments dropped (dup or out of space)
    0 fragments dropped after timeout
    0 packets forwarded
 15797 packets not forwardable
    0 redirects sent

ROUTING STATS:
    0 bogus redirect calls
    0 routes created by redirects
    0 routes modified by redirects
    0 lookups which failed
    0 lookups satisfied by a wildcard

LANCE STATS:
    0 Count of Memory errors
    0 Packets greater than 1100 bytes
    0 Buffer Error on Receive
 25891773 Bytes received
    0 CRC Errors on rcv
    0 Framing Errors on rcv
 25887532 Multicast bytes received
 249828 Multicast packets received
    0 Overflow errors
 249905 Tot packets received
    1 Packets lost, no system resources
    0 Packets lost, no user resources
    0 Unrecognized destination on rcv
    0 Babble errors on xmit
 12868 Tot bytes transmitted
    0 Buffer Error counter
    0 Packets xmitted without heartbeat
    1 Packets deferred
    0 Packets xmitted with loss of carrier
    0 Packets xmitted with a late collision
 7666 Multicast bytes transmitted
    0 Packets xmitted > 1 retry
 134 Multicast packets xmitted
    0 Packets xmitted w/1 retry
 184 Tot packets transmitted
    0 Packets not xmitted after 15 retries
    0 Packets xmitted with underflow error

ICMP STATS:
    0 calls to icmp_error
    0 errors not generated 'cuz old message was icmp
    0 messages with bad code fields
    0 messages < minimum length
    0 bad checksums
    0 messages with bad length
Input histogram:
  destination unreachable: 39
    0 message responses generated
```

```

Active Internet connections
PCB      Proto Recv-Q Send-Q Local Address      Foreign Address    (state)
609860   0      0      591  xds8.dsg.dec.com.771 aguru.dsg.dec.com.1058 ESTABLISHED
60A460   0      0      0    0.0.0.0.771        0.0.0.0.0        LISTEN
60B060   0      0      0    0.0.0.0.6000       0.0.0.0.0        LISTEN

SLEEPS:
&selwait == 0x97EAO
      PCB      name          event  awakened  prio BFs
      575610  Inetd        97EAO   0         26

Mbuf statistics:
18/128 mbufs in use:
 6 mbufs allocated to data
 1 mbufs allocated to packet headers
 3 mbufs allocated to socket structures
 6 mbufs allocated to protocol control blocks
 1 mbufs allocated to routing table entries
 1 mbufs allocated to interface addresses
0/16 mapped pages in use
0 interface pages allocated
32 Kbytes allocated to network (8% in use)
0 requests for memory denied
0 requests for memory delayed
0 calls to protocol drain routines
--END--

```

2.4.2 Using ping

You can use the UNIX ping command to verify the network hardware, Internet protocol (IP), and ICMP layers. Tracking a single-point hardware or software failure on the Internet network can be difficult.

The ping command sends ICMP ECHO_REQUEST packets to network hosts. The ping command utilizes the ICMP protocol's mandatory ECHO_REQUEST datagram to elicit an ICMP ECHO_RESPONSE from a host or gateway. ECHO_REQUEST datagrams have an IP and ICMP header, followed by a destruct time value and an arbitrary number of pad bytes to fill out the packet. The default length of a datagram length is 64 bytes, but you can change the length with the ping command.

Entering ping *host name* without any options will either report host is alive or no answer from host. Options to the ping command report additional statistics. See your UNIX system documentation for details.

Command syntax

```
/etc/ping [options] host [datasize[npackets]]
```

Option	Function
-d	Turn on the SO_DEBUG flag on the socket.
-l	Provide a long output that gives more statistical information.
-r	Bypass the normal routing tables and send directly to a host on an attached network. If the host is not on a directly attached network, an error is returned. You can use this option to “ping” a local host through an interface that has no route through it.
-v	Provide verbose output. This option lists other received ICMP packets beside ECHO_RESPONSE.

3

Troubleshooting

This chapter describes how to troubleshoot the terminal by:

- Using a flowchart.
- Using error codes displayed by the terminal.
- Checking a table of general problems.

3.1 Identifying the Terminal's Configuration

You can identify the terminal's hardware configuration by checking the firmware revision level.

To identify this terminal ...

VT1000
VT1200

DECimage 1200

Check the title bar in the ...

Terminal Manager's window (Figure 2-1).

Customize Image dialog box (Section 5.6) from the Terminal Manager's window.

3.2 Troubleshooting by Flowchart

Figure 3–1 is a flowchart to help you diagnose and troubleshoot the terminal's operating problems. When you turn on the terminal:

- The two keyboard LEDs blink only during keyboard testing or to report an error.
- The system logic board LED turns on and off. To see the LED, look through the ventilation slits on the side of the system box (Section 1.1).
- The monitor displays a pie graph representing the progress of the self-tests.

At the end of a successful power-up sequence:

- The keyboard bell rings.
- The keyboard LEDs turn off.
- The system logic board LED turns off.
- The pie graph is replaced by the Terminal Manager window (Figure 2–1)
- The diagnostic summary box contains the message:

```
All Diagnostics Passed
```

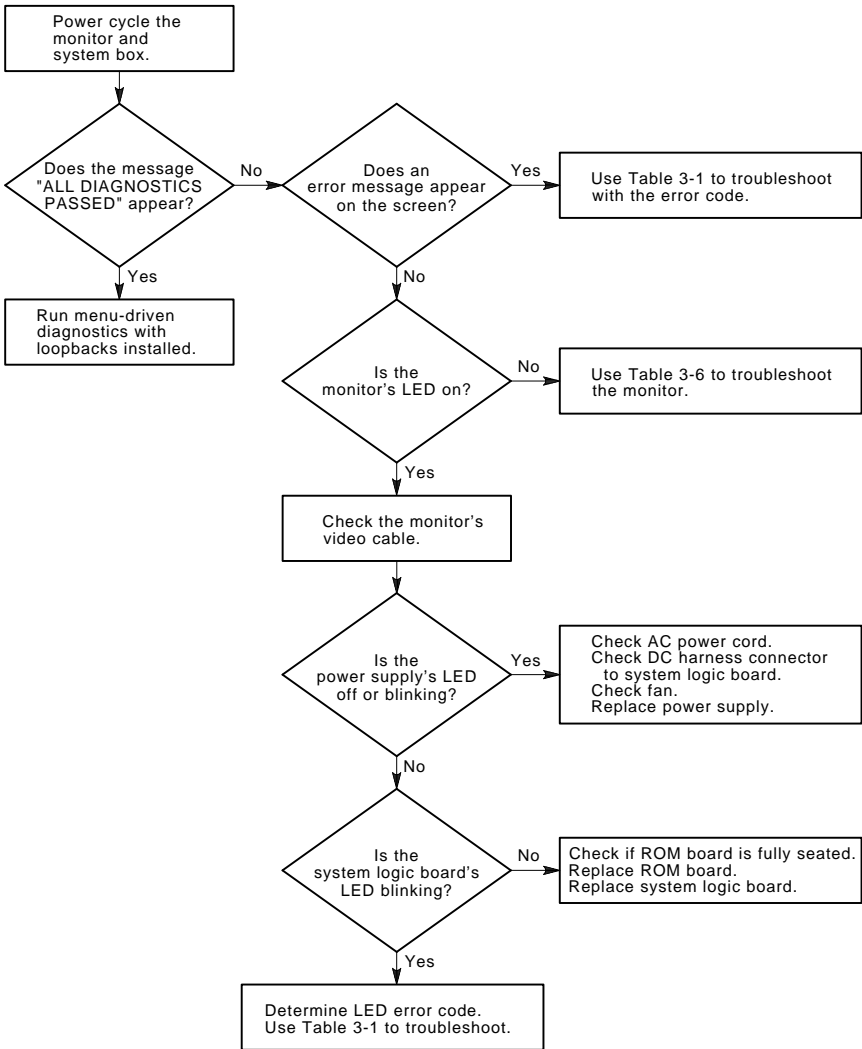

MA-0513-90.DG

Figure 3-1 Terminal Troubleshooting Flowchart

3.3 Troubleshooting by Error Code

If the terminal's self-tests find an error, the terminal displays an error message on the screen and an LED error code on the keyboard LEDs and system logic board LED. Table 3-1 lists all error codes reported in screen error messages, keyboard LEDs, and the system logic board LED.

To troubleshoot errors, turn the system box's power switch off and on, then note any screen error messages or LED error codes. Section 3.3.1 lists all screen error messages. If the screen error message is unavailable, see Section 3.3.2 to read the LED error codes. Then find the error code and recommended solution in Table 3-1.

Table 3-1 Troubleshooting by Error Code

Error Code	Solution *
11	Replace the system logic board (4.6).
12	Replace the ROM board (4.5).
13	See Table 3-2.
14	Run the NVR Checksum Test from the Diagnostics dialog box (2.1.2). If the same error occurs, replace the system logic board (4.6).
15	Replace the system logic board (4.6).
16	Replace the system logic board (4.6).
17	Replace the system logic board (4.6).
18	Replace the system logic board (4.6).
19	Replace the system logic board (4.6).
21	Replace the system logic board (4.6).
22	Replace the system logic board (4.6).
23	Replace the system logic board (4.6).
24	Check the Ethernet T-connector or daisy chain for proper termination. Install a T-connector with two terminators (no Ethernet cable), then turn the system box's power switch off and on. If the same error occurs, replace the system logic board (4.6).
	If error code 28 occurs after error code 24, the Ethernet is only partially terminated. Again, check the Ethernet T-connector or daisy chain for proper termination.

*Section numbers follow the solution.

Table 3–1 (Cont.) Troubleshooting by Error Code

Error Code	Solution *
25	Replace the system logic board (4.6).
26	Run the Mouse Port Test with external loopback, using the Diagnostics dialog box (2.1.2). If the same error occurs, replace the system logic board (4.6). Otherwise, replace the mouse (4.9).
27	Replace the keyboard (4.9). If the same error occurs, replace the system logic board (4.6).
28	Turn the system box's power switch off and on. If the same error occurs, replace the system logic board (4.6).
29	Replace the system logic board (4.6).
31	Replace the system logic board (4.6).
32	Check and adjust the setting of the monitor selection switch (1.1.2). Then turn the system box's power switch off and on. If the same error occurs, replace the system logic board (4.6).
33	Replace the system logic board (4.6).
34	Replace the system logic board (4.6).
43	Replace the image board (4.3).

*Section numbers follow the solution.

Table 3–2 Troubleshooting Error Code 13

Error Message	Solution *
MAIN Memory Error - 13	Replace the system logic board (4.6).
Optional RAM Simm 1 Error - 13	Replace SIMM card 1 (4.4). Turn the system box's power switch on. If the same error occurs, replace the RAM controller board (4.2).
Optional RAM Simm 2 Error - 13	Replace SIMM card 2 (4.4). Turn the system box's power switch on. If the same error occurs, replace the RAM controller board (4.2).

*Section numbers follow the solution.

Table 3–2 (Cont.) Troubleshooting Error Code 13

Error Message	Solution *
Optional RAM Simm 3 Error - 13	Replace SIMM card 3 (4.4). Turn the system box's power switch on. If the same error occurs, replace the RAM controller board (4.2).
LEVEL0 Errors →	
Memory error overflow - 13	Replace the system logic board (4.6).
No System Memory for BSS section - 13	Replace the system logic board (4.6).
Refresh counter error - 13	Replace the system logic board (4.6).
System Memory Address Decode - (RUN 2) - 13	Replace the system logic board (4.6).
System Memory Refresh or address decode error - 13	Replace the system logic board (4.6).
*Section numbers follow the solution.	

3.3.1 Screen Error Messages

Tables 3–3 and 3–4 list level 0 and level 1 screen error messages. An error code appears at the end of each message.

Table 3–3 Level 0 Screen Error Messages

Screen Error Message
LEVEL0 ERROR → CPU Register - 11
LEVEL0 ERROR → Illegal ROM Format or No ROM - 12
LEVEL0 ERROR → ROM CHECKSUM - 12
LEVEL0 ERROR → Memory error overflow - 13
LEVEL0 ERROR → No System Memory for BSS section - 13
LEVEL0 ERROR → Refresh counter error - 13
LEVEL0 ERROR → System Memory Address Decode - (RUN 2) - 13
LEVEL0 ERROR → System Memory Refresh or address decode error - 13

Table 3–3 (Cont.) Level 0 Screen Error Messages

Screen Error Message
LEVEL0 ERROR → Display interrupt too fast error - 28
LEVEL0 ERROR → Display interrupt too slow error - 28
LEVEL0 ERROR → Extraneous Host Interface Interrupt Occurrence - 28
LEVEL0 ERROR → Extraneous Interrupt 2 Occurrence - 28
LEVEL0 ERROR → Extraneous Interrupt 1 Occurrence - 28
LEVEL0 ERROR → Extraneous Non-Maskable Interrupt Occurrence - 28
LEVEL0 ERROR → Extraneous Window Violation Occurrence - 28
LEVEL0 ERROR → Illegal OPCODE Occurrence - 28
LEVEL0 ERROR → No display interrupt error - 28
LEVEL0 ERROR → Perpetual (pending) Display Interrupt - 28
LEVEL0 ERROR → Trap Interrupt Occurrence - 28
LEVEL0 ERROR → Video clock control register - 29
LEVEL0 ERROR → IO path error - 31
LEVEL0 ERROR → Illegal video switch selection - 32
LEVEL0 ERROR → Lance not stopped - 33

Table 3–4 Level 1 and Menu-Driven Screen Error Messages

Screen Error Message
ROM Checksum Error - 12
MAIN Memory Error - 13
Optional RAM Simm 1 Error - 13
Optional RAM Simm 2 Error - 13
Optional RAM Simm 3 Error - 13
NVR Checksum Error - 14
Host Port Error - 15
Printer Port Error - 16
DUART Timer 1 - 17

Table 3–4 (Cont.) Level 1 and Menu-Driven Screen Error Messages

Screen Error Message
Keyboard Port Error - 18
Mouse Port Error - 19
DUART Timer 2 - 21
VIDEO RAM Error - 22
Ethernet ROM Error - 23
Ethernet Port Error - 24
Video Error - 25
Mouse Error - 26
Keyboard Error - 27
Image Error - 43

3.3.2 Reading LED Error Codes

The terminals report hardware failures by using the red LED on the system logic board and the hold and lock LEDs on the keyboard. This section describes how to interpret the LED error codes. If the screen cannot display an error message, determine the LED error code and use Table 3–1 to troubleshoot the error.

Table 3–5 LED Error Reporting Method

Self-Tests	System Logic Board LED	Keyboard LEDs	Screen Message
Level 0	Repeating blinking pattern	Not used	Yes (if possible)
Level 1 and menu-driven diagnostics	Blinking pattern (one time)	Blinking pattern (one time)	Yes (if possible)

Level 0 LED Errors

Turn on the terminal. Level 0 testing begins. If a level 0 error occurs, the diagnostics try to display an error message on the screen and on the system logic board LED. Level 0 errors are not reported on the keyboard LEDs.

To interpret blinking LED error codes on the system logic board:

The LED displays the two-digit decimal error code in the following pattern:

First digit → 2-second pause → second digit → 6-second pause

Each digit is represented by the corresponding number of blinks: on for 0.5 seconds and off for 0.5 seconds.

For example, if there is a ROM checksum error (error code 12), the system logic board LED:

Blinks one time → pauses for 2 seconds → blinks two times → pauses for 6 seconds → repeats the sequence.

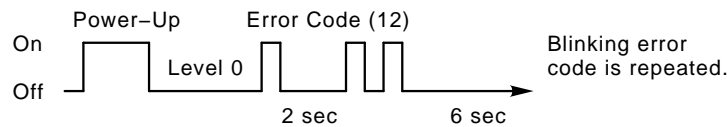

See Table 3–1 for a list of error codes and recommended solutions.

Level 1 LED Error Codes

After level 0 testing is complete, the operating system starts and level 1 testing starts. When a level 1 error occurs, the screen displays an error message in the upper-left corner and testing continues. When level 1 testing is complete, the keyboard bell does not ring and diagnostics displays the error message in three places.

- On the screen, in the diagnostic summary box
- On the keyboard LEDs (one time, no repeat)
- On the system logic board LED (one time, no repeat)

To interpret blinking error codes on the keyboard LEDs:

For each two-digit error code, the first digit blinks on the hold LED and the second digit blinks on the lock LED.

The pattern of blinks is

First digit → 2-second pause → second digit → 6-second pause

Each digit is represented by the corresponding number of blinks: on for 0.5 seconds and off for 0.5 seconds.

For example, if there is an optional memory error (error code 13), the keyboard LEDs display the error message as follows:

Hold LED blinks one time → 2-second pause → lock LED blinks three times.

Keyboard LEDs do not repeat the error code sequence.

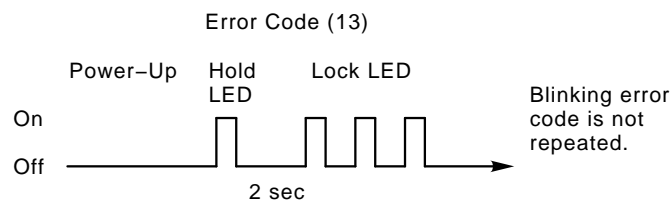

See Table 3–1 for a list of error codes and recommended solutions.

3.4 Troubleshooting General Problems

Table 3–6 describes some general operating problems with possible causes and suggested solutions.

Table 3–6 Troubleshooting the Terminal

Symptom	Probable Cause	Solution*
Monitor Problems		
Monitor's power LED does not turn on.	The monitor's power cord is not connected.	Check the cord connection on the rear of system box and the monitor.
	The system box's power cord is not connected.	Check the cord connection on the rear of system box and at the power outlet.
	No ac power.	Connect the monitor power cord directly to the power outlet.
	Monitor.	See the monitor's service guide.

*Section numbers follow the solution.

Table 3–6 (Cont.) Troubleshooting the Terminal

Symptom	Probable Cause	Solution*
Problems at Power-Up		
The Terminal Manager window appears, and the bell tone sounds, but the terminal cannot communicate with host.	The terminal's ThinWire port cable is loose.	Check the cable connection on the rear of system box.
	Group codes are incorrect or missing.	Enter the group codes (Chapter 5).
	Host node or IP address is incorrect or missing	Enter the host name or host IP address (Chapter 5).
	Font paths are incorrect or missing.	Enter the font paths (Chapter 5).
	Terminal IP address is wrong or missing.	Enter the terminal address (Chapter 5).
	LAT slide bars are set incorrectly.	Reset the slide bars. See the <i>Installing and Using ...</i> guide for the terminal.
	ThinWire communication port circuits are faulty.	Run the Ethernet loopback test (2.1.2).
	The terminal's serial host or printer port cable is loose.	Check the cable connection on the rear of system box.
The serial communication port circuits are faulty.	Run the host port or printer port loopback tests (2.1.2).	

*Section numbers follow the solution.

Table 3–6 (Cont.) Troubleshooting the Terminal

Symptom	Probable Cause	Solution*
Problems at Power-Up		
	The baud rate is incorrect.	Check the Transmit and Receive speeds in the Customize Host Port or Customize Printer Port dialog boxes.
	System logic board.	Replace the system logic board (4.6).
A continuous keyclick sound occurs at power-up.	Object(s) are on the keyboard	Remove all objects from the keyboard.
	Keyboard	Replace the keyboard (4.9).
After power-up, one or more keyboard LEDs stay on, or the LEDs do not go through their power-up sequence.	Keyboard.	Replace the keyboard (4.9).
	System logic board.	Replace the system logic board (4.6).
DECimage 1200: The power-up test fails, and the pie graph is distorted.	The incorrect ROM board is installed.	Replace the ROM board with an image ROM board (4.5).
Error code 24 occurs, then error code 28 occurs.	The Ethernet is partially terminated.	Check the Ethernet T-connector or daisy chain for proper termination.
Screen Display Problems		
The screen is off-center or rotated.	Electromagnetic field.	Move the terminal to another location. Adjust the screen by using one of the screen alignment patterns from the Session pull-down menu (2.1.3) and the monitor's service guide.
	System logic board.	Replace the system logic board (4.6).

*Section numbers follow the solution.

Table 3–6 (Cont.) Troubleshooting the Terminal

Symptom	Probable Cause	Solution*
Screen Display Problems		
Horizontal or vertical line appears on screen.	Monitor.	See the monitor's service guide.
Screen display distorted or jittery.	Nearby devices are creating electrical interference.	Move the terminal away from the electrical devices.
	Monitor is out of alignment.	See the monitor's service guide.
	System logic board.	Replace the system logic board (4.6).
No bell tone or keyclick.	Keyboard speaker transducer.	Replace the keyboard (4.9).
In local mode, the terminal displays different characters than those typed.	Alternate character set selected.	Select the correct character set by using the Customize General dialog box.
	Wrong keyboard language selected.	Select the correct keyboard language by using the Customize Keyboard dialog box.
	Keyboard.	Replace the keyboard (4.9).
	System logic board.	Replace the system logic board (4.6).
While on-line with the host, the terminal displays different characters than those typed. (The terminal works in local mode.)	Transmit and receive speeds are incorrect.	Set the speeds to match the host using the Customize Host Port or Customize Printer Port dialog box.
	Bits per character or parity setting is wrong.	Set the Word Size or Parity setting to match the host, using the Customize Host Port or Customize Printer Port dialog box.
	Stop bits setting is incorrect.	Set the Stop Bits number to match the host, using the Customize Host Port or Customize Printer Port dialog box.

*Section numbers follow the solution.

Table 3–6 (Cont.) Troubleshooting the Terminal

Symptom	Probable Cause	Solution*
Screen Display Problems		
	System logic board.	Replace the system logic board (4.6).
The screen display does not scroll. The hold indicator is on.	The F1 (Hold) key was pressed.	Press F1 to resume scrolling.
The terminal appears locked and does not respond to data from the host.		Use the Commands pull-down menu in the VTE window: <ol style="list-style-type: none"> 1. Click on Clear Communications to clear the terminal. 2. Click on Reset Terminal to reset the terminal.
The screen is blank.	CRT saver feature is activated.	Press any key to restore the screen display.
	ROM board.	Replace the ROM board (4.5).
Messages are garbled, and reverse question marks appear on the screen.	XON/XOFF flow control is not enabled.	Click on the XOFF at 64 or 128 button in the Customize Host Port or Customize Printer Port dialog box.
	System logic board.	Replace the system logic board (4.6).
The terminal crashes after warming up. The screen goes blank and power supply LED turns off.	Thermal shutdown—fan is off.	Check the fan connector. Replace the fan (4.8).
	Power supply.	Replace the power supply (4.7).

*Section numbers follow the solution.

Table 3–6 (Cont.) Troubleshooting the Terminal

Symptom	Probable Cause	Solution*
Image Problems (DECimage 1200)		
No image or a partial image is displayed.	Image board error.	Run the image hardware test (2.1.2). If the image hardware test fails, replace the image board (4.3).
*Section numbers follow the solution.		

4

Removing and Replacing FRUs

This chapter shows you how to remove and replace the field replaceable units (FRUs) for the terminal. See Appendix B for the recommended spares lists.

CAUTION



Always use a static protection kit (PN 29-26246-00) when handling any internal components.

This guide does not cover the FRUs for the VR150, VR262, VR315, VR319, and VRE01 monitors. For information on the monitors, see the following guides:

Monitor	Document Title	Order Number
VR150	VR150 Pocket Service Guide	EK-VR150-PS
VR262	VR262 Pocket Service Guide	EK-VR262-PS
VR315	VR315 Service Guide	EK-VR315-SV
VR319	VR319 Service Guide	EK-VR319-SV
VRE01	VRE01 Service Guide	EK-VRE01-SV

4.1 Cover

To remove the system box cover:

1. Turn the system box's  power switch off (O).
2. Turn the monitor's  power switch off (O).
3. Disconnect both power cords from the rear of the system box.
4. Disconnect the monitor video cable from the rear of the monitor.
5. Remove the monitor from the top of the system box.
6. Release the top cover of the system box by pressing in the two push tabs on the side of the box with the power switch, as shown.
7. Slowly lift the top cover until you release the hinges on the other side of the box. Then lift the top cover completely off the system box.

To install the system box cover, reverse steps 1 through 7.

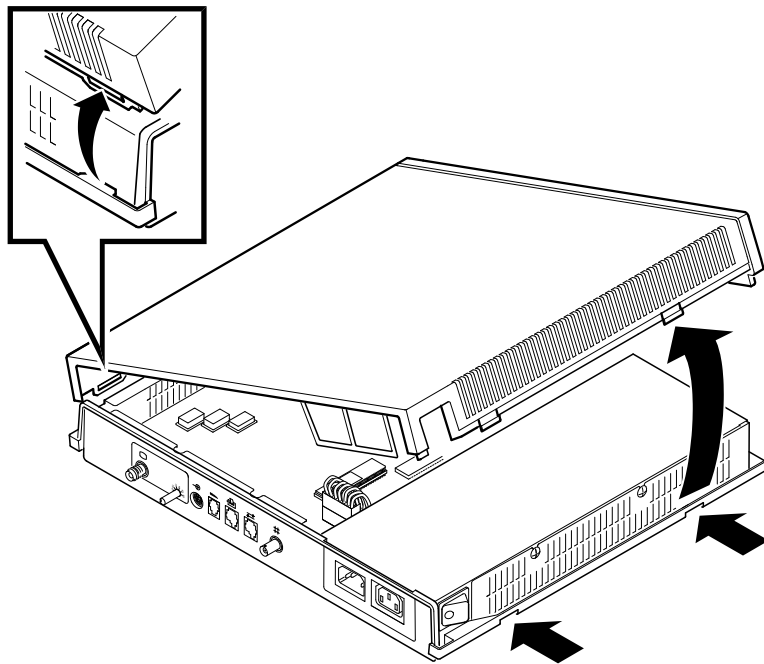

GSF_0839_89A.DG

4.2 RAM Controller Board (VT1000 / VT1200 Only)

CAUTION

The image board and the SIMM cards can be damaged by electrostatic discharge. Handle the RAM board by its cover or strap. Avoid contact with any components or circuitry within the system box.

To remove the RAM controller board:

1. Remove the system box cover (Section 4.1).
2. Release the standoff clips by gently pushing each clip away from the board and lifting up on the edges of the board.
3. Grasp the strap of the memory controller board and pull up firmly.
4. Place the board on top of the power supply's metal cover, with the strap side down. Use the metal cover as an antistatic work surface to remove and replace SIMM cards.
5. Remove the SIMM card(s) from the old RAM controller board and install them on the new RAM controller board (Section 4.4).

To install the RAM controller board, reverse steps 1 through 3.

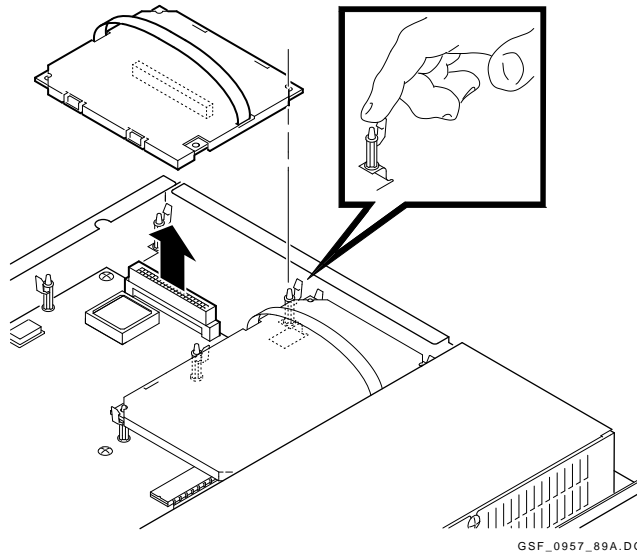

4.3 Image Board (DECimage 1200 Only)

CAUTION

The image board and the SIMM cards can be damaged by electrostatic discharge. Handle the image board by its cover or strap. Avoid contact with any components or circuitry within the system box.

To remove the image board:

1. Release three standoff clips (①, ②, ③) by gently pushing each clip away from the image board and lifting up on the edges of the board.
2. Hold the short strap on the image board and *gently* pull up to loosen the board from the standoffs.
3. Release the other three standoff clips (④, ⑤, ⑥) as in step 1.
4. Grasp the long strap of the image board and pull up *firmly* to release the image board connector from the system logic board.
5. Place the board on top of the power supply's metal cover, with the strap side down. Use the metal cover as a work surface to remove and replace SIMM cards.
6. Remove the SIMM card(s) from the old RAM controller board or image board and install them on the new image board (Section 4.4).

To install the image board, reverse steps 1 through 4.

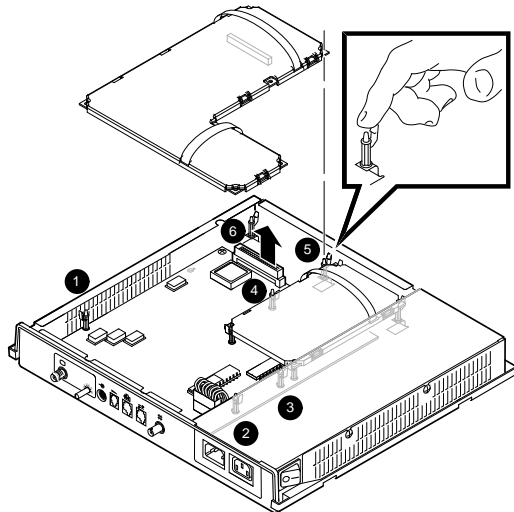

4.4 SIMM Cards

CAUTION

SIMM cards can be damaged by electrostatic discharge. Handle the SIMM card by the side edges of the card. Avoid contact with the gold contact fingers on the card.

To remove SIMM cards from the RAM controller board or the image board:

1. Remove the system box cover (Section 4.1).
2. Remove the RAM controller board (Section 4.2) or image board (Section 4.3).
3. Remove the SIMM cards in order, starting with connector 4MB and ending with connector 2MB.
 - Release both sides of the SIMM card from the connector by gently pushing each clip away from the sides of the card. Tilt the SIMM card at a 45-degree angle toward the edge of the RAM board or image board.
 - Grasp the edges of the SIMM card firmly and lift up to remove it from the connector.
 - Place the SIMM cards on top of the power supply's metal cover.

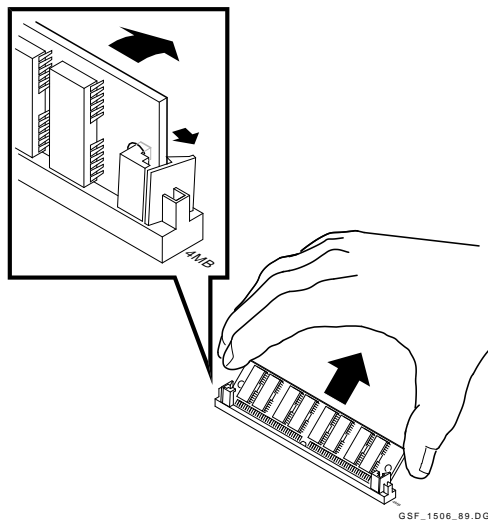

Installing SIMM Cards

To install SIMM card(s) on the RAM memory controller board or image board:

1. Remove the SIMM cards from the shipping bag and place them on top of the power supply's metal cover. This prevents electrostatic damage.
2. Install the first SIMM card in the connector labeled 2MB, the second SIMM in 3MB, and the last SIMM in 4MB.
 - Insert the SIMM card into the connector at a 45-degree angle. Face the components on the SIMM card toward the components on the memory controller board or image board. Line up the center key slot on the SIMM card with the connector key on the memory controller board or image board.
 - Push down on the top of the card to seat it in the connector.
 - Raise the SIMM card into a standup position, until both sides of the card lock into the connector tabs.

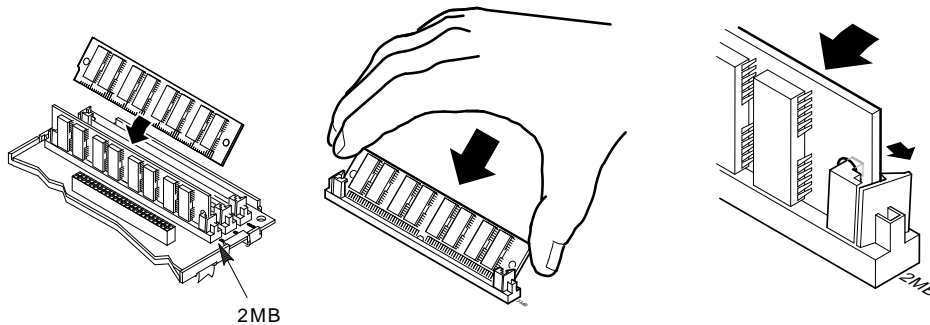

MA-0508-90.DG

4.5 ROM Board

To remove the ROM board:

CAUTION

The ROM board can be damaged by electrostatic discharge. Handle the ROM board by its cover or strap.

1. Remove the system box cover (Section 4.1).
2. Release the standoff clips by gently pushing each clip away from the board and lifting up on the edges of the board.
3. Grasp the strap of the ROM board and pull up firmly.

To install the ROM board, reverse steps 1 through 3.

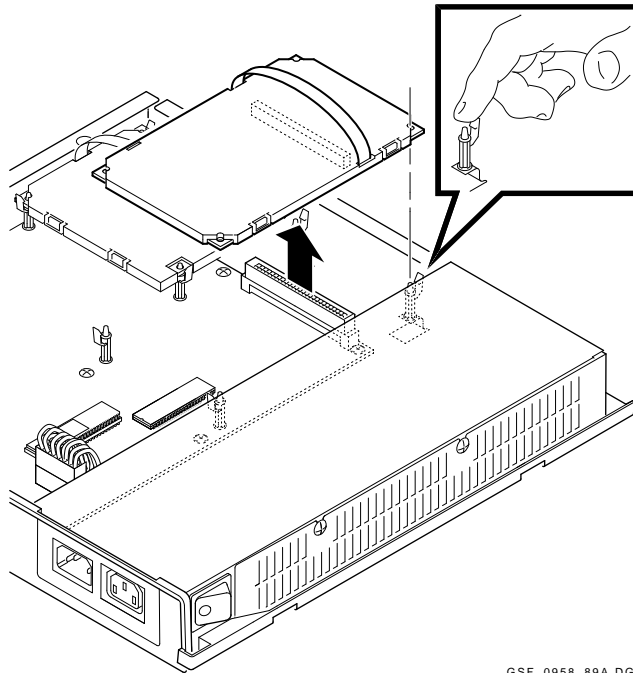

4.6 System Logic Board

Nonvolatile RAM (NVR) on the system logic board stores the user's customized settings, including group codes, host name or IP address, font paths, and the terminal IP address. Before you remove the system logic board, make sure the user has a record of the customized settings (Section 5.1). You will reenter required settings after installing the new system logic board.

To remove the system logic board:

1. Remove the system box cover (Section 4.1).
2. Remove the ROM board (Section 4.5).
3. Remove the RAM controller board (Section 4.2) or image board (Section 4.3), if installed.
4. Unplug the power supply connector by pressing in the release clip and lifting up on the connector.

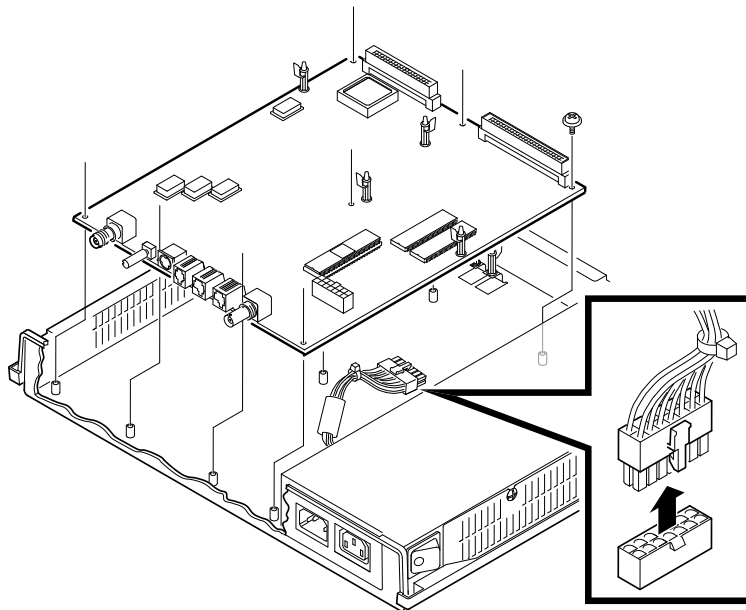

GSF_1507_89.DG

58 Removing and Replacing FRUs

5. Disconnect all cables connected to the logic board through the rear panel.
6. Remove the eight Phillips screws holding the system logic board to the system box.

CAUTION

To meet grounding requirements, make sure you replace all eight screws.

7. Slide the system logic board toward the front of the box, so the board is clear of the connectors from the rear panel.
8. Lift the system logic board out of the system box.

To install the system logic board, reverse steps 1 through 8.

- Due to the spring washers on the Ethernet and monitor connectors, some force is needed to install the logic board. Press the board firmly against the connector side of the enclosure and insert a screw into the center hole of the board to hold the board in place. Then replace the remaining screws.
- If the knob comes off the monitor selection switch, align the black stripe of the knob with the arrowhead on the switch and push the knob on. Make sure the arrowhead is pointing to 0 on the switch itself, which is 1 on the system box label.

Reentering the User's Customized Settings

After you replace the system logic board, see Chapter 5 to enter and save the user's required settings. These include group codes, host name or IP address, font paths, and the terminal IP address.

4.7 Power Supply

To remove the power supply:

1. Remove the system box cover (Section 4.1).
2. Disconnect the power cable on the system logic board.
3. Loosen the two screws holding the power supply to the system box.
4. Lift up the screw side of the power supply to slide the power supply's holding tabs out of the slots on the bottom of the chassis.
5. Lift the power supply out of the system box.

To install the power supply, reverse steps 1 through 5.

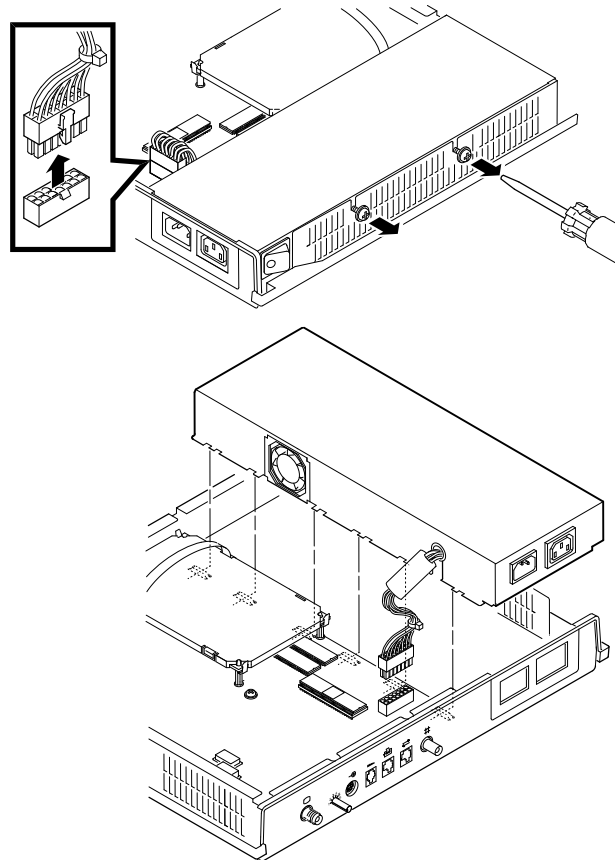

4.8 Fan

To remove the fan:

1. Remove the system box cover (Section 4.1).
2. Remove the power supply (Section 4.7).
3. Disconnect the fan's power wire from the power supply, as shown. There are two fan connectors. With the fan facing toward you, the power wire is on the right.
4. Slide the fan out of the power supply.

To install the fan, reverse steps 1 through 4.

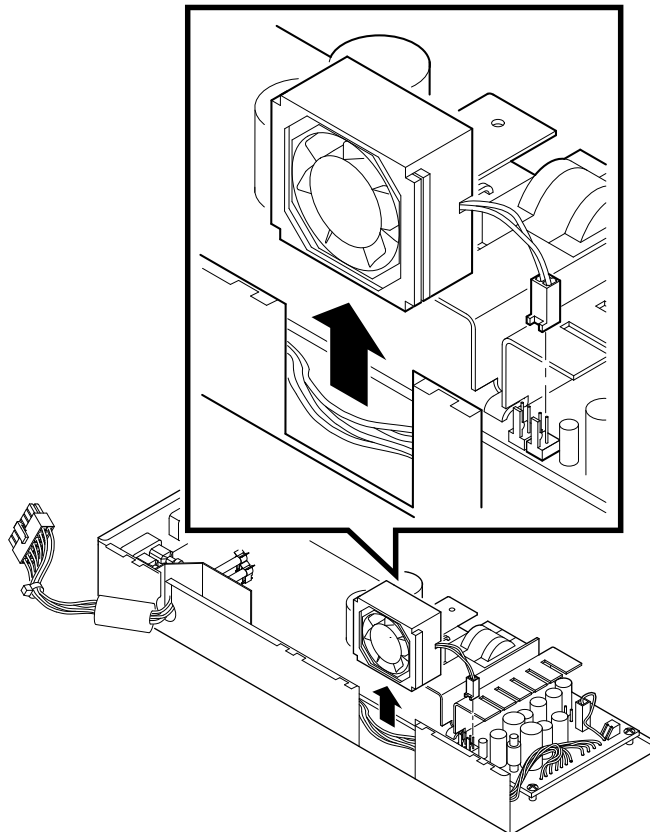

4.9 Keyboard, Mouse, and Printer

Disconnect the keyboard, mouse, or printer from the rear of the system box. You do not have to turn off the power.

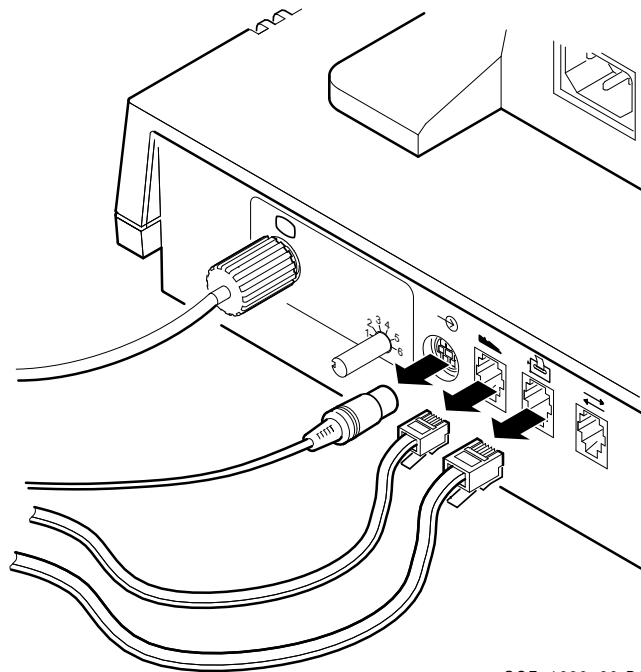

GSF_1689_89.DG

To install a keyboard, mouse, or printer, connect its cable to the appropriate connector on the rear of the system box.

5

Starting a Session

This chapter describes how to start a session with the terminal. You can use this procedure to reenter and save a user's customized settings after replacing the system logic board. For detailed procedures with supporting diagrams, see the "Getting Started" chapter in the terminal's *Installing and Using . . .* guide.

The chapter also describes how to override passwords, using the secure reset feature.

5.1 Before You Start—Required Information

Before you begin a session, you need the following information. See the system manager if you need assistance.

Host name(s) or IP address(es):

Font path: _____

Group code(s) (LAT): _____

Terminal IP address (TCP/IP): _____

Name server IP address (TCP/IP): _____

5.2 Starting a Session on a VMS System

You can start an X window or video terminal (VTE) session on a system using a local area transport (LAT).

1. Turn on the terminal. After the power-up self-tests are complete, the Terminal Manager window appears.
2. From the Terminal Manager window, pull down the Customize menu and choose the **LAT . . .** menu item.
 - Move the mouse until the arrow-shaped pointer is on the **Customize** menu name in the Terminal Manager's menu bar.
 - Press (click) and hold down the left button on the mouse. The Customize pull-down menu appears.
 - While holding down the button, move the pointer down to the **LAT . . .** menu item.
 - Release the mouse button. The Customize LAT dialog box appears.

NOTE

If you accidentally choose another menu item, dismiss the new dialog box that appears by clicking on its Cancel button.

3. Enter a group code into the Customize LAT dialog box.
 - Use your keyboard to enter the group code into the text entry field.
 - Click on the **Add** button. The new group code appears in the Group Codes scroll box.
 - Repeat this procedure for each group code.
 - Click on the **OK** button to dismiss the Customize LAT dialog box.
4. Choose the **Font Path . . .** menu item from the Customize menu.
 - Pull down the **Customize** menu in the Terminal Manager's menu bar.
 - Choose the **Font Path . . .** menu item. The Customize Font Path dialog box appears.

64 Starting a Session

5. The LAT Font Path text entry field already has the word ROM entered. Enter a comma (,) followed by a font host name and two colons.

For example:

```
|ROM ,BETA: :  
-----
```

Then click on the **OK** button to dismiss the Customize Font Path dialog box.

You may have to wait several minutes before the message `set font path succeeded` appears in the Messages area of the Terminal Manager window. Sometimes it takes a few minutes for the terminal to receive the message identifying the font path host. The terminal retries for 30 seconds every 2 1/2 minutes. If the wait is too long, your system manager may be able to increase the host's multicast message frequency.

6. Save the group code(s) and font path so you do not have to enter them each time you turn on the terminal.
 - Pull down the **Customize** menu in the Terminal Manager window.
 - Choose the **Save Current Settings** menu item.
7. Start a video terminal (VTE) or X window session.
 - Pull down the **Create** menu in the Terminal Manager window.
 - To begin a video terminal (VTE) session, choose the **LAT Terminal Window . . .** menu item. The LAT Terminal Window Service Select dialog box appears.
 - To begin an X window session, choose the **LAT X Session . . .** menu item. The LAT X Session Service Select dialog box appears.

8. Choose a host system and connect to it.

The names of the hosts you can access appear in the scroll box at the top of the dialog box. The host names should correspond to the group codes you have entered.

- If necessary, click on the scroll bar to find the name of the host you want to log into.

You may have to wait several minutes before the host you want appears. Click on the **Update Known Services** button to update the scroll box. If the wait is too long, your system manager may be able to increase the multicast message frequency.

- Click on the name of the host. The host name is highlighted and appears in the text entry field at the bottom of the window.
 - Click on the **Add** button. The host name is added to the Preferred Services scroll box. Only add hosts you frequently log in to.
 - Click on the **Save** button. The terminal saves the host names you add to the Preferred Services scroll box, so you do not have to enter them each time you turn your terminal on.
 - Make sure the name of the host you want to connect to appears in the text entry field at the bottom of the window.
 - Click on the **Connect** button. An X window or video terminal login prompt appears.
9. Log in to the X window or video terminal (VTE) session. Press the **Return** key on the keyboard after entering your username and password.

The X window session manager or VTE window appears.

5.3 Starting a Session on an ULTRIX or UNIX System

You can start a video terminal or X window session, using TCP/IP TELNET or TCP.

1. Turn on the terminal. After the power-up self-tests are complete, the Terminal Manager window appears.
2. Determine if you have to assign an IP address for the terminal.
 - If BOOTP address resolution is available on the system, the terminal can determine its own IP address at power-up. Ask the system manager. If BOOTP is available, you can go to step 8.
 - If BOOTP is not available, continue with step 3 to enter the terminal's IP address.
3. From the Terminal Manager window, pull down the Customize menu and choose the **TCP/IP . . .** menu item.
 - Move the mouse until the arrow-shaped pointer is on the **Customize** menu name in the Terminal Manager's menu bar.
 - Press (click) and hold down the left button on the mouse. The Customize pull-down menu appears.
 - While holding down the button, move the pointer down to the **TCP/IP . . .** menu item.
 - Release the mouse button. The Customize TCP/IP dialog box appears.

NOTE

If you accidentally choose another menu item, dismiss the new dialog box that appears by clicking on its Cancel button.

4. Enter the terminal's IP address and subnet mask.
 - Enter the IP address in the IP Address (manual) text entry field.
 - Enter the IP subnet mask into the IP Subnet Mask text entry field.
 - Click on the **OK** button to dismiss the Customize TCP/IP dialog box.

5. Choose the **Font Path . . .** menu item from the Customize menu.
 - Pull down the **Customize** menu in the Terminal Manager's menu bar.
 - Choose the **Font Path . . .** menu item. The Customize Font Path dialog box appears.
6. Enter a font path into the Customize Font Path dialog box.
 - Click on the **TFTP Font Path** button under the Font Path Selection title.
 - Click on the TFTP Font Path text entry field. The word ROM is already entered. Enter a comma (,) followed by a font host IP address.

For example:

```
|ROM ,123.45.67.89:/vt1200/fonts.dir  
-----
```
 - Click on the **OK** button to dismiss the Customize Font Path dialog box.

You may have to wait several minutes before the Set font path succeeded message appears.
7. Save the terminal's IP address and the font path(s) so you do not have to enter them each time you turn on the terminal.
 - Pull down the **Customize** menu in the Terminal Manager window.
 - Choose the **Save Current Settings** menu item.
8. Start a session.
 - Pull down the **Create** menu in the Terminal Manager window.
 - Choose the **TELNET Terminal Window . . .** menu item. The TELNET Terminal Window Host Select dialog box appears.
9. Use your keyboard to enter the IP address(es) or names of the host(s) you want to connect to.
10. Click on the **Save** button so you do not have to enter the information each time you turn on the terminal.
11. Click on the button next to the host you want to connect to.
12. Click on the **Connect** button. A video terminal (VTE) window appears.

68 Starting a Session

13. Log in to the host as you would on a conventional video terminal.

14. If you want to run an X window session:

- Enter the appropriate commands to enable your terminal to run an X window application:

If you are using the UNIX C-shell

```
% setenv DISPLAY your_terminal's_IP_address:0
```

If you are using the UNIX Bourne or Korn shell

```
$ DISPLAY=your_terminal's_IP_address:0
```

```
$ export DISPLAY
```

- Begin an X window application by entering the appropriate command. For example, the following command starts a DECterm application:

```
$ dxterm
```

- You can also run the DECwindows session manager from your ULTRIX host by entering one of the following command lines:

For UWS Version 2.1

```
$ dxsession -d your_terminal's_IP_address
```

For UWS Version 2.2

```
$ dxsession
```

5.4 Ending a Session

1. Pull down the **Session** menu in the Terminal Manager's menu bar.
2. Click on the **Quit** menu item.

5.5 Using Secure Reset

Performing a **Secure Reset** allows you to override saved passwords. You may need to perform a secure reset if a user locks the terminal's customize dialog boxes, then forgets the customize security password.

To perform a secure reset:

CAUTION

Secure Reset erases all NVR (except the Secure Reset Count) and resets all terminal settings to their factory defaults.

1. Turn on the terminal. After the power-up self-tests are complete, the Terminal Manager window appears.
2. Press and hold down the **[Shift]** and **[Ctrl]** keys on the keyboard.
3. With your other hand, move the mouse until the pointer is on the **Session** menu name.
4. Click and hold the left mouse button, known as mouse button 1 (MB1). The Session pull-down menu appears.

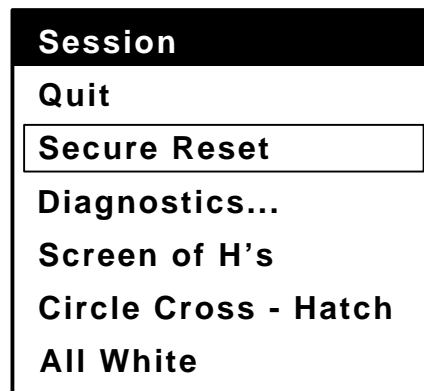

MA-0514-90.DG

NOTE

If the user has chosen the left-handed settings for the mouse, MB1 is the button on the right.

5. Release the **[Shift]** and **[Ctrl]** keys.
6. Move the mouse pointer down to the **Secure Reset** menu item.

70 Starting a Session

7. Release MB1. the Secure Reset prompt box appears.

MA-0515-90.RAGS

8. Click on the **Yes** button. The terminal resets all settings to the factory default, overriding the security and pause passwords. Secure reset also increases the **Secure Reset Count** by one. The secure reset count is at the lower-left corner of the Terminal Manager window.

5.6 Displaying the Customize Image Dialog Box (DECimage 1200 Only)

To display the Customize Image dialog box, choose the **Image** menu item from the Terminal Manager's Customize menu.

1. Point to the **Customize** menu name in the Terminal Manager's menu bar. Click and hold MB1 to pull down the Customize menu.

72 Starting a Session

2. Drag the pointer down to the **Image...** menu item. Release MB1 to display the Customize Image dialog box.

A

Related Documents

You can order the following documents from Digital. This guide refers to these documents.

Table A-1 Related Documents

Documents	Order Number
Installing and Using the VT1000 Video Terminal	EK-V1000-UG
Installing and Using the VT1200 Video Terminal	EK-V1200-UG
Installing and Using the DECimage 1200 Video Terminal	EK-V120I-IN
VT1000 Illustrated Parts Breakdown	EK-V1000-IP
DECimage 1200 Illustrated Parts Breakdown	EK-D1200-IP
VT1000 / VT1200 System Box Maintenance Print Set	MP-02989-01
VR150 Pocket Service Guide	EK-VR150-PS
VR262 Pocket Service Guide	EK-VR262-PS
VR315 Service Guide	EK-VR315-SV
VR319 Service Guide	EK-VR319-SV
VRE01 Service Guide	EK-VRE01-SV

B

Recommended Spares List

This appendix lists the recommended spares for the terminal. For monitor FRUs, see the monitor's service guide (Appendix A).

Description	Part Number
VX10A-AA/AB System Box Field Replaceable Units (VT1000 and VT1200 Video Terminals)	
Bottom cover, plastic	74-39208-01
Dress panel, plastic	74-39906-01
Fan	70-26582-01
Front bezel, plastic (VT1000)	74-39210-01
Front bezel, plastic (VT1200)	74-39210-02
Monitor selection switch knob	74-39905-01
Power supply assembly	H7109-A
RAM memory controller board	54-19807-01
ROM board (VT1000 / VT1200)	54-19803-01
Screw for power supply and system logic board	90-09984-07
SIMM card	VX10X-MD
System logic board	54-19783-01
Standoff, nylon	12-19857-05
Top enclosure assembly, plastic	70-27014-01

Description	Part Number
VX11A-AA/AB System Box Field Replaceable Units (DECimage 1200 Video Terminal)	
Bottom cover, plastic	74-39208-01
Dress panel, plastic	74-39906-01
Fan	70-26582-01
Front bezel, plastic	74-39210-03
Image board assembly	70-27988-02
Monitor selection switch knob	74-39905-01
Power supply assembly	H7109-A
ROM board (DECimage 1200)	54-19803-03
Screw for power supply and system logic board	90-09984-07
SIMM card	VX10X-MD
System logic board	54-19783-01
Standoff, nylon (unkeyed)	12-19857-01
Standoff, nylon (keyed)	12-19857-05
Top enclosure assembly, plastic	70-27014-01
Mouse	VSXXX-AA
Cables	
Power cord, system box to monitor	17-00442-32
ThinWire Ethernet cable	BC16M-15
VR150, VR315, or VR319 video cable	17-02441-01
VR262 or VRE01 video cable	17-02636-01
Loopback Connectors	
Loopback connector, MMJ (H3103-00)	12-25083-01
Mouse loopback connector	12-25628-01
ThinWire Ethernet T-connector (H8223-00)	12-25869-01

76 Recommended Spares List

Description	Part Number
ThinWire Ethernet cable 50-ohm terminator (H8225-00) (Two are required.)	12-26318-01
Power Cords for System Box	
Australia, New Zealand	BN19H-2E
Austria, Belgium, Finland, France, Germany, Netherlands, Norway, Portugal, Spain, Sweden	BN19C-2E
Canada	BN19P-1K
Denmark, Israel	BN19K-2E
Ireland, United Kingdom	BN19A-2E
Italy	BN19M-2E
Switzerland	BN19E-2E
USA	17-00606-02
Tablet VSXXX-AB	
Printed circuit board and cable	29-25998-00
Puck	29-25996-00
Stylus	29-25995-00
Tablet assembly	29-25997-00
Tablet bottom enclosure	29-26000-00
Tablet top enclosure	29-25999-00

Keyboard	Standard	Word Processing (WPS)
North American/United Kingdom	LK401-AA	LK402-AA
Belgium/Flemish	LK401-AB	LK402-AB
Canada (English)	LK401-AQ	LK402-AQ
Canada (French)	LK401-AC	LK402-AC
Denmark	LK401-AD	LK402-AD
Finland	LK401-AF	LK402-AF
France	LK401-AP	LK402-AP
Germany/Austria	LK401-AG	LK402-AG
Hebrew	LK401-AT	None
Italy	LK401-AI	LK402-AI
Netherlands	LK401-AH	LK402-AH
Norway	LK401-AN	LK402-AN
Portugal	LK401-AV	LK402-AV
Spain	LK401-AS	LK402-AS
Sweden	LK401-AM	LK402-AM
Switzerland (French)	LK401-AK	LK402-AK
Switzerland (German)	LK401-AL	LK402-AL
