

digital

SYSTEM
INSTALLATION MANUAL

VAX11
780

VAX-11/780 System Installation Manual

First Edition, October 1978

Copyright © 1978 by Digital Equipment Corporation

The material in this manual is for informational purposes and is subject to change without notice. Digital Equipment Corporation assumes no responsibility for any errors which may appear in this manual.

Printed in U.S.A.

This document was set on DIGITAL's DECset-8000 computerized typesetting system.

The following are trademarks of Digital Equipment Corporation, Maynard, Massachusetts:

DIGITAL	DECsystem-10	MASSBUS
DEC	DECSYSTEM-20	OMNIBUS
PDP	DIBOL	OS/8
DECUS	EDUSYSTEM	RSTS
UNIBUS	VAX	RSX
	VMS	IAS

CONTENTS

	Page
CHAPTER 1 INTRODUCTION	
CHAPTER 2 HANDLING THE PACKAGED EQUIPMENT	
2.1 GENERAL.....	2-1
2.2 BOXED EQUIPMENT	2-1
2.3 CONSTRAINTS ON THE MOVING OR EQUIPMENT	2-1
CHAPTER 3 HARDWARE INSTALLATION	
3.1 GENERAL.....	3-1
3.2 SHIPMENT INVENTORY	3-1
3.3 UNPACKING BOXES	3-1
3.4 UNCRATING THE CABINETS.....	3-2
3.5 CABINET DISASSEMBLY	3-4
3.5.1 System Cabinet Disassembly	3-4
3.5.2 Unibus Expander Cabinet Disassembly	3-6
3.5.3 TE16 Cabinet Disassembly	3-7
3.6 CABINET JOINING, LEAVING, AND ASSEMBLY	3-8
3.7 POWER CHECK	3-10
3.8 INSTALLATION OF THE CONSOLE LA36.....	3-12
3.9 INTERCABINET CABLING AND INSTALLATION OF PERIPHERAL DEVICES	3-12
3.10 SYSTEM START UP PROCEDURE	3-22
CHAPTER 4 SYSTEM CHECKOUT AND ACCEPTANCE	
4.1 GENERAL.....	4-1
4.2 MICRODIAGNOSTICS.....	4-1
4.3 LOADING THE DIAGNOSTIC SUPERVISOR (ESSAA) DIRECTLY.....	4-3
4.4 INDIRECT CONSOLE COMMAND FILES	4-4
4.5 CPU CLUSTER EXERCISER PACKAGE	4-5
4.6 TAPE DRIVE FUNCTIONAL TIMER (ESMAB)	4-8
4.7 RPOX FUNCTIONAL DIAGNOSTIC (ESRBA).....	4-10
4.8 DMC EXERCISER (ESDBB).....	4-12
4.9 VAX/VMS BOOTSTRAP FROM AN RP DISK DRIVE.....	4-13
4.10 VAX/VMS BOOTSTRAP FROM AN RK06 DISK DRIVE.....	4-14
4.11 DEVICE MNEMONIC IDENTIFICATION.....	4-16
4.12 TRANSFERRING DIAGNOSTIC FILES: FLOPPY→SYSTEM.....	4-17
4.13 RELOADING THE DIAGNOSTIC SUPERVISOR	4-18

CONTENTS (Cont)

		Page
4.14	TAPE RELIABILITY (ESMAA).....	4-18
4.15	RP/RK/RM FORMATTER (ESRAB).....	4-19
4.16	RP/RK/RM DISK RELIABILITY PROGRAM (ESRAA)	4-20
4.17	MULTITERMINAL EXERCISER (ESTBA)	4-21
4.18	LOCAL TERMINAL DIAGNOSTIC.....	4-22
4.19	LINE PRINTER DIAGNOSTIC (ESAAA)	4-24
4.20	BUS INTERACTION (ESXBA).....	4-25
4.21	USER ENVIRONMENT TEST PACKAGE (UETP)	4-28

APPENDIX A SBI EXPANDER CABINET INSTALLATION

FIGURES

Figure No.	Title	Page
2-1	Mobile Lifter Using Rigged Wooden Brace and Protection Plate	2-2
3-1	Spanner Wrench.....	3-2
3-2	Unbolting Cabinet Crate Corners.....	3-3
3-3	Wheel Lock Assembly	3-4
3-4	Top Cover Fastener.....	3-5
3-5	Stabilizer Arm and Leveling Pad	3-6
3-6	Removing the Front Panel of a TE16 Cabinet or a Unibus Expander Cabinet	3-7
3-7	VAX-11/780 System Cabinet Configuration.....	3-18
3-8	Cabinet Frame with Bolting Plates, Stabilizer Channels, and Interlock Rod.....	3-9
3-9	Varieties of Power Plugs and Receptacles.....	3-11
3-10	LA36 Packaging	3-13
3-11	Unibus Ribbon Cable Connection	3-14
3-12	Unibus Expander Cabinet, Cable Arrangement, Rear View	3-15
3-13	TE16 Cable Connections	3-16
3-14	RP05/RP06 Cable Connections.....	3-18
3-15	RM03 Cable Connections.....	3-19
3-16	DR11-B System Unit Slot Allocation.....	3-20
3-17	M957 Split Lug Cable Board	3-21
3-18	Circuit Breaker Locations.....	3-23

TABLES

Table	Title	Page
1-1	Related Manuals	2-1
3-1	Tools Necessary for Uncrating and Assembling Cabinets	3-2
3-2	AC Power Requirements	3-10
4-1	Guideline for Selecting Number of Load Test Users.....	4-29

CHAPTER 1 INTRODUCTION

This manual provides instructions for installing and accepting the VAX-11/780 computer system. These procedures have been developed for use by DIGITAL field service engineers and/or user personnel. The manual lists the steps that must be taken, following equipment delivery, in preparation for final acceptance by the customer. Table 1-1 lists related manuals.

The unpacking and pre-installation procedures are designed to ensure that the VAX-11/780 system shipped is the one actually ordered by the customer; and that the hardware, software and documentation for that system are present, accounted for, and at the current revision level.

NOTE

The entire VAX-11/780 system and appropriate documentation should be on hand before installation is begun. Any discrepancies must be noted and dealt with. It is difficult to collect on damages once equipment has been unpacked.

Chapter 2 lists procedures and precautions to be followed when moving the packaged VAX-11/780 equipment to the installation site. Chapter 3 lists hardware installation procedures, from inventory to power up. Chapter 4 provides system checkout and acceptance procedures. SBI expander cabinet and TU45 tape drive installation procedures, together with instructions for running additional diagnostic programs, are listed in Appendix A. Add-on procedures will be listed in Appendix B.

Table 1-1 Related Manuals

Title	Document Number	Notes
VAX-11/780 Hardware User's Guide	EK-UG780-UG-PRE	Available on hard copy*
VAX-11/780 Diagnostic System User's Guide	EK-DS780-UG-PRE	Available on hard copy*
LA36/LA35 DECwriter II User's Manual	EK-LA3635-OP-003	Available on hard copy*
TE16/TE10W/TE10N DECmagtape Transport Maintenance Manual	EK-0TE16-TM-001	Available on hard copy*
RK06/RK07 Disk Drive User's Manual	EK-RK067-UG-001	Available on hard copy*
RP05/RP06 Disk Drive Installation Manual	EK-RP056-IN-PRE	Available on hard copy*
RM02/RM03 Disk Subsystem Service Manual	EK-RM023-SV-001	Available on hard copy*
LP11/LS11/LA11 Line Printer Manual	EK-LP11-TM-006	Available on hard copy*
DZ11 User's Guide	EK-DZ110-OP-PRE	Available on hard copy*
CR11/CM11 Card Reader System Installation Manual	EK-0CR11-TM-004	Available on hard copy*
DR11-B/DA11-B Manual	EK-DR11B-TM-004	Available on hard copy*

*These manuals are shipped with the devices that they describe. Additional copies can be ordered from:

Digital Equipment Corporation
444 Whitney Street
Northboro, MA 01532
Attention: Printing and Circulation Services NR2/M15
Customer Services Section

CHAPTER 2

HANDLING THE PACKAGED EQUIPMENT

2.1 GENERAL

DIGITAL ships the various items of the VAX-11/780 system packed in crates and boxes. Some of the equipment is mounted on skids as well. The customer is responsible for moving the packaged equipment to the installation site.

This chapter discusses the equipment packaging and the proper ways to transport it from the receiving area to the installation area.

2.2 BOXED EQUIPMENT

All VAX-11/780 system cabinets and some large peripheral devices are mounted on casters. Other peripheral devices are mounted separately on skids or packed in consolidated boxes and attached to skids by hold down rails. Fork lifts and mobile lifters can be used to move the packaged equipment. Figure 2-1 shows how a wooden brace can be used to protect the equipment when two mobile lifters are used.

If the consolidated boxes containing more than one item cannot be moved to the installation area, they must be opened so that the small box contents can be moved separately.

2.3 CONSTRAINTS ON THE MOVING OF EQUIPMENT

The moving of cabinets from the receiving area to the installation area should have been planned in advance of the delivery date. Ensure that the sizes of doors, elevators, passageways, and ramps have been checked for height, width, and turning radius.

When moving the equipment, take the following precautions.

1. Move the cabinets carefully. They may become unstable when tilted more than 10 degrees from the vertical. If the cabinets are moved up ramps, additional precautions may be necessary.
2. Avoid jolting the cabinets.
3. Observe the caution symbols printed on the cabinet containers. When the cabinets are moved, they should be pushed on the side indicated. Two of the four casters on each cabinet are locked to facilitate movement in one direction.
4. The cabinets are mounted on shock-isolating casters. Normally, the cabinets will arrive without skids. If a fork lift is used, the prongs should be inserted from the front or the back of a double-width cabinet, or from the end of a single-width cabinet.
5. If the installation site is on an upper level, a crane or an elevator capable of lifting up to 2000 pounds should be used.

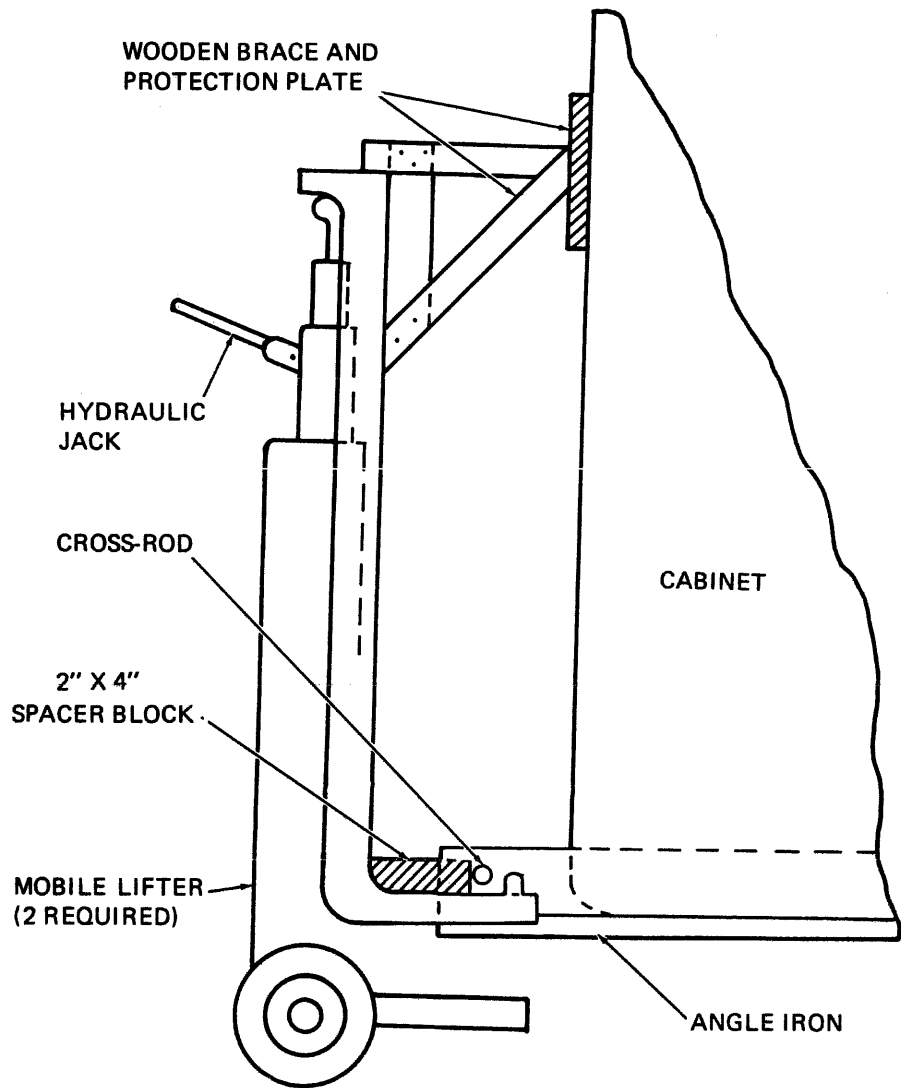

TK-0367

Figure 2-1 Mobile Lifter Using Rigged Wooden Brace and Protection Plate

CHAPTER 3 HARDWARE INSTALLATION

3.1 GENERAL

This chapter provides a step-by-step procedure for shipment inventory, unpacking, cabinet assembly, cabling, and power up for the VAX-11/780 system.

3.2 SHIPMENT INVENTORY

1. Check that all VAX-11/780 equipment has been moved to the designated installation site (a customer responsibility).
2. Inventory all equipment against the shipping list accompanying the shipment.
3. Ensure that all system cabinets and free-standing peripherals are in their containers and unopened.
4. Ensure that all separate boxes and consolidated boxes are sealed.
5. Any opened packages or cabinets should be called to the attention of the customer and documented on the LARS report.
6. Notify the branch manager or branch supervisor of any missing or incorrect items.
7. Have the customer contact the carrier to locate any missing items.
8. Have the branch service manager check with the DIGITAL Traffic and Shipping Department if the carrier does not have the missing items.
9. Check all boxes for external damage (dents, holes, smashed corners).
10. Notify the customer of all damages and list them on the LARS report. Photographs will be useful in clarifying the extent of the damage.

3.3 UNPACKING BOXES

1. Locate the "Open Me First" box.
2. Open all boxes and inventory the contents against the shipping/accessory list in the "Open Me First" box.
3. Inspect the equipment for damages. Report any damage to the customer and on the LARS report.
4. If the damage is extensive, call the local service supervisor for instructions on how to proceed.

3.4 UNCRATING THE CABINETS

Several tools are necessary for uncrating and assembling the cabinets (Table 3-1).

Table 3-1 Tools Necessary for Uncrating and Assembling Cabinets

3/8 inch wrench or adjustable wrench
7/16 inch wrench or adjustable wrench
9/16 inch wrench or adjustable wrench
No. 2 Phillips screwdriver
Thin bladed tool (e.g., a metal rule)
Spirit level (optional)
Spanner wrench (Unibus expander cabinet opening tool, part no. DEC 1213091)(Figure 3-1)
VAX-11/780 cabinet key (part no. DEC 12-14664-02, supplied with cabinet)

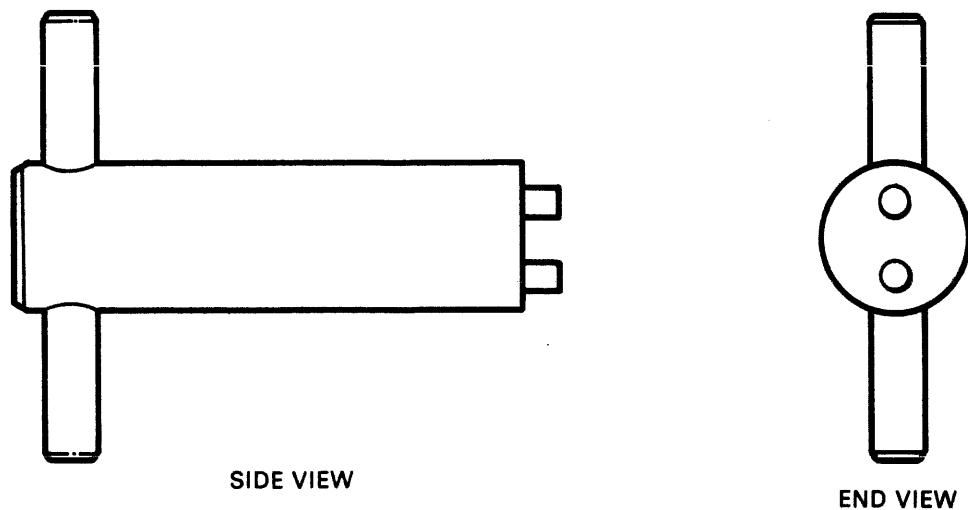

TK-0368

Figure 3-1 Spanner Wrench

Uncrate each cabinet, as follows:

1. Using a 7/16 inch wrench, unbolt the bottom protector from the crate. Remove the bottom protector.
2. Unbolt the corners of the crate with the 7/16 inch wrench, in diagonally opposite pairs, as shown in Figure 3-2.
3. Unbolt the top of the crate with the 7/16 inch wrench.
4. Remove the pieces of the crate.

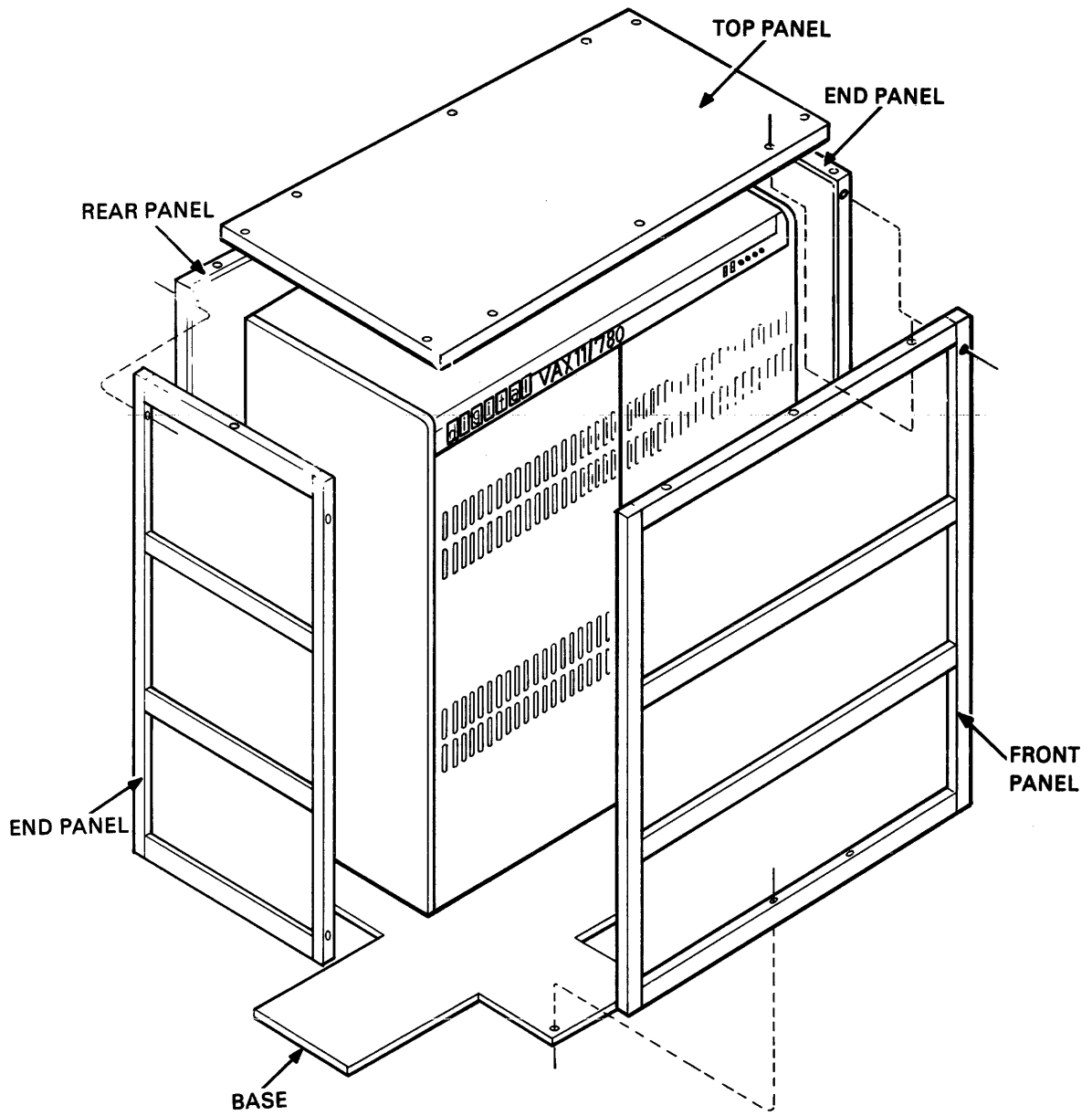

TK-0370

Figure 3-2 Unbolting Cabinet Crate Corners

3.5 CABINET DISASSEMBLY

The double-width system cabinet and the one or more expander cabinets must be partially disassembled before they can be joined into a single, integrated structure.

3.5.1 System Cabinet Disassembly

1. Remove the wheel lock assembly from each caster at the end of the system cabinet, as shown in Figure 3-3.
2. Open the front and rear doors of the CPU cabinet. The key is in the "Open Me First" box.
3. Remove each rear door by swinging it 90 degrees and lifting it off the hinges.
4. Remove each front door by swinging it 90 degrees and lifting the pin at the bottom of the door.
5. Release the top cover by reaching up to the under side of the back of the top cover and rotate the 1/4 turn fastener counter-clockwise as shown in Figure 3-4. Push the cover forward and lift it off. The released fastener will hang by a wire attaching it to the top cover.

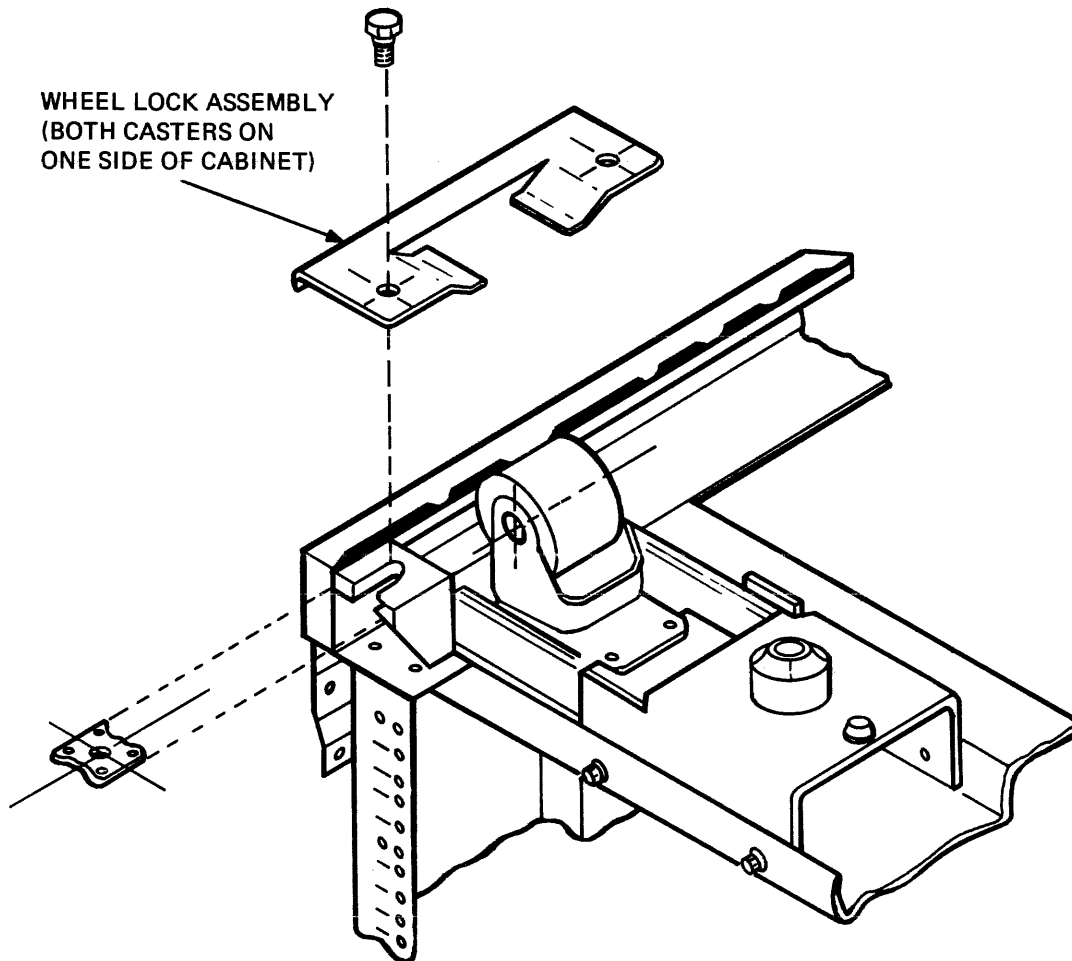

TK-0362

Figure 3-3 Wheel Lock Assembly

6. Remove the trim strips from the front and rear right side of the system cabinet. The cabinet control panel must be removed before the right front strip can be removed. Remove the screws from each end of the panel and lay the panel carefully on top of the cabinet frame, keeping the wires intact.
7. Remove the floppy disk drive shipping bracket.

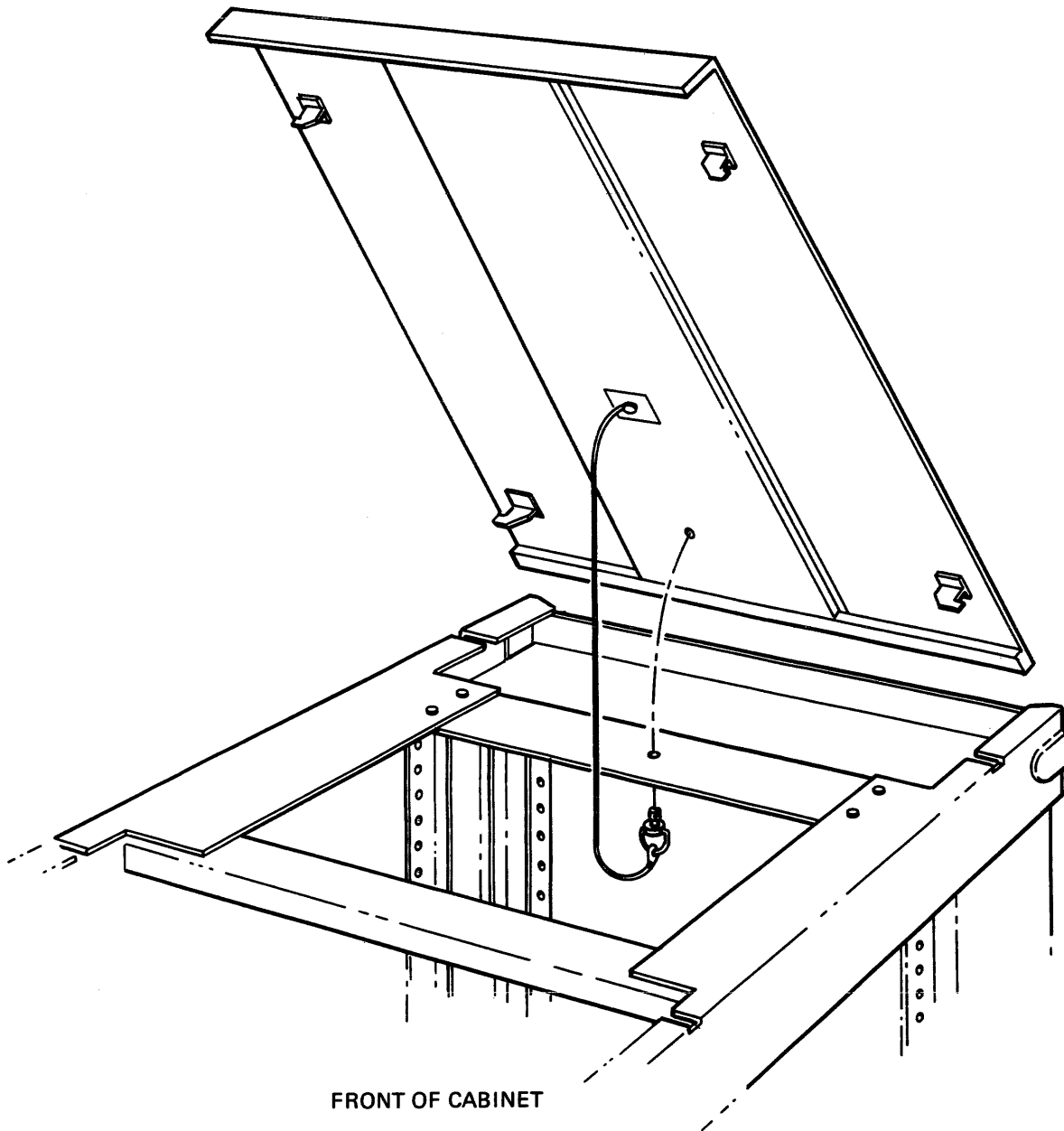
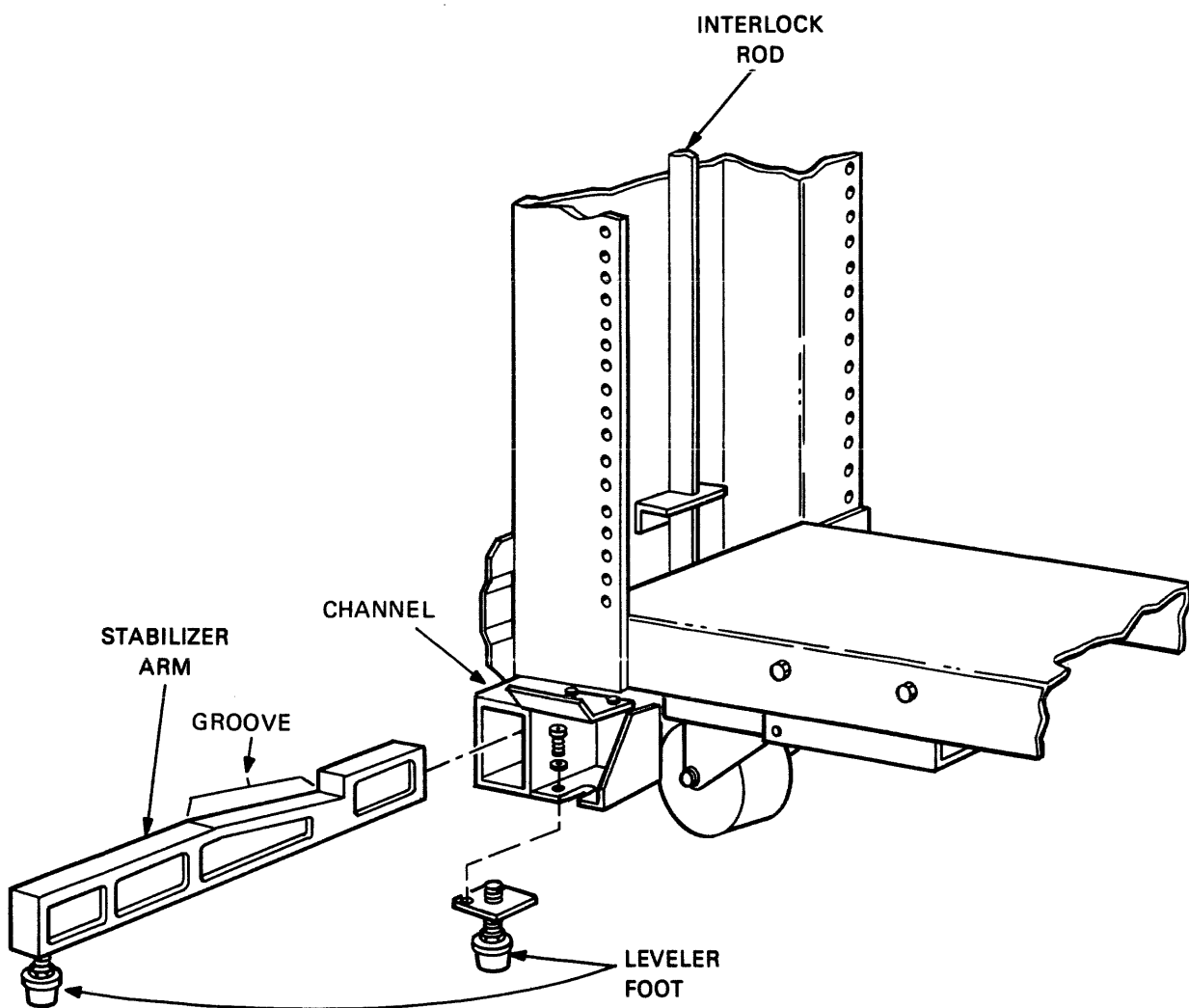

Figure 3-4 Top Cover Fastener

3.5.2 Unibus Expander Cabinet Disassembly

1. Open the rear door of the Unibus expander cabinet with the opening tool (Figure 3-1).
2. Open the door 90 degrees and lift it off the hinges.
3. Remove the top louvered panel. If a TE16 is present, remove the gray trim panel. Remove the bottom panel of the Unibus expander cabinet (Figure 3-6.)
4. Release and remove the top cover.
5. Remove the wheel lock assembly of both casters at the left end of the Unibus expander cabinet by removing two bolts in each assembly (Figure 3-3).
6. Untape the stabilizer arms in the right and left sleeve assemblies of the Unibus expander cabinet (Figure 3-5). Slide the arms forward out of the sleeves, while lifting the interlock rod approximately 1 inch vertically.



TK-0365

Figure 3-5 Stabilizer Arm and Leveling Pad

7. Locate the leveler pads in the “Open Me First” box and screw one into each stabilizer arm.
8. Reinsert the stabilizer arms into the sleeve assemblies while raising the interlock rod.
9. Remove the front, rear, and top trim strips.

3.5.3 TE16 Cabinet Disassembly

If one or more TE16s are present, disassemble each as follows. Otherwise, go to Paragraph 3.6 to begin joining the cabinets.

1. Remove the wheel lock assemblies from both casters at the left side of the cabinet (Figure 3-3).
2. Remove the top of the cabinet.
3. Open and remove the rear door.
4. Remove the bottom front panel using a thin bladed tool (Figure 3-6).
5. Untape the stabilizer arms in the right and left end sleeve assemblies. Slide the arms forward out of the sleeves while lifting the interlock rod approximately 1 inch to free the left side interlock with the sleeve.
6. Locate the leveler pads and screw one into each stabilizer arm.
7. Reinsert the stabilizer arms into the sleeve assemblies while raising the interlock rod.
8. Repeat the preceding seven steps for each TE16.

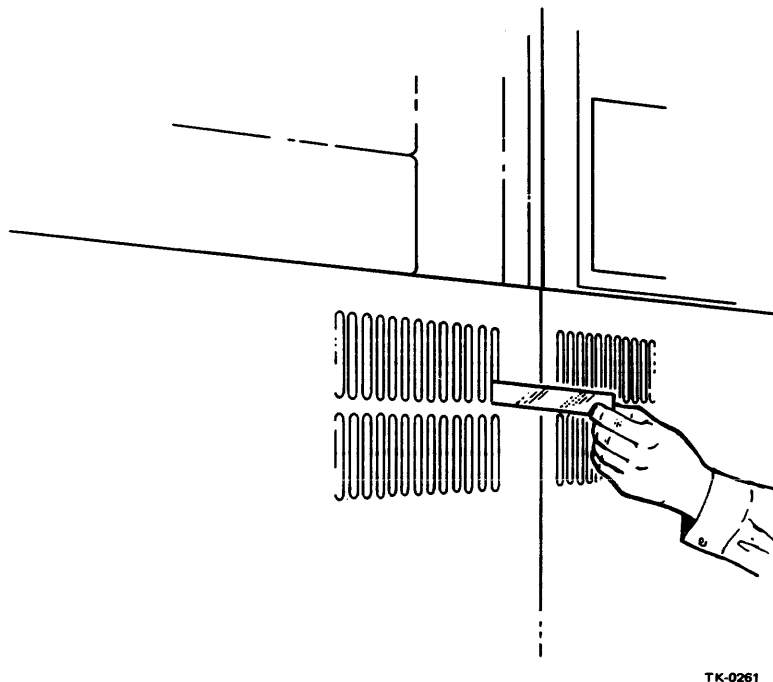
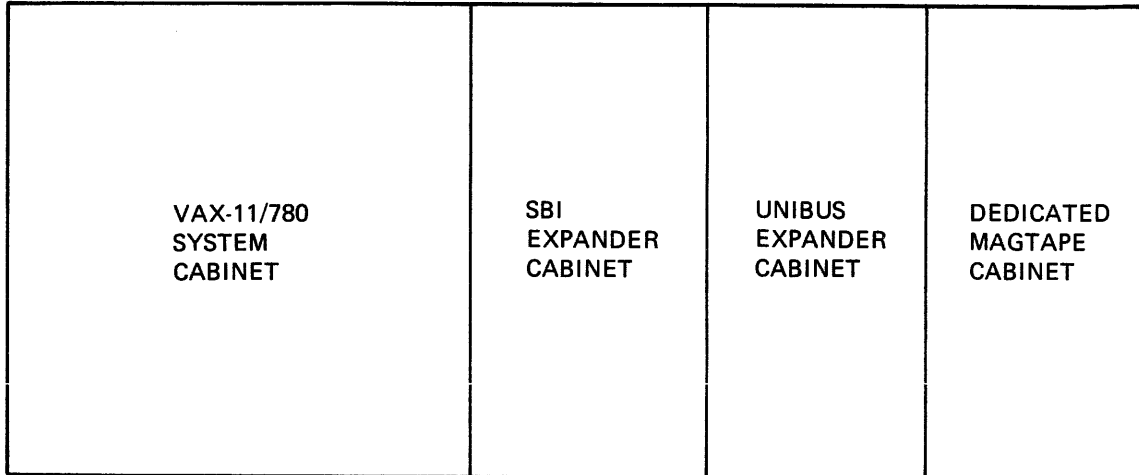

Figure 3-6 Removing the Front Panel of a TE16 Cabinet or a Unibus Expander Cabinet

3.6 CABINET JOINING, LEVELING, AND ASSEMBLY

1. Push the cabinets to adjacent positions. They should be arranged from left to right as follows: system cabinet (left most), SBI expander cabinet (if present), Unibus expander cabinet, and TE16 cabinet(s) (right most, if present) (Figure 3-7).



TK-0262

Figure 3-7 VAX-11/780 Cabinet Configuration

2. Insert leveler feet into the brackets at the four corners of each cabinet.
3. Use a 9/16 inch wrench to lower the feet until all four feet of each cabinet touch the floor.
4. Adjust the system cabinet height until most of the cabinet weight rests on the feet. Use a spirit level to bring the cabinet horizontal. Note that if the CPU cabinet is not level, the front door will not line up properly.
5. Adjust the height and fore and aft position of the adjoining cabinet until the corresponding bolt holes in the mounting plates at the top and bottom of each cabinet are perfectly aligned. If the VAX-11/780 system includes an SBI expander cabinet, proceed with the steps listed in Appendix A, Paragraph A.1, at this point.
6. Insert a 1/4-20 bolt into each hole in the mounting plates shown in Figure 3-8. Add nuts and tighten them.
7. Repeat steps 5 and 6 for each remaining cabinet.
8. Lower the pads on the stabilizer arms to obtain minimum contact with the floor. The arms should still be free enough to slide.
9. Replace the top trim strips between the cabinets (four screws each).
10. Replace the front and rear trim strips between the cabinets (four screws each).

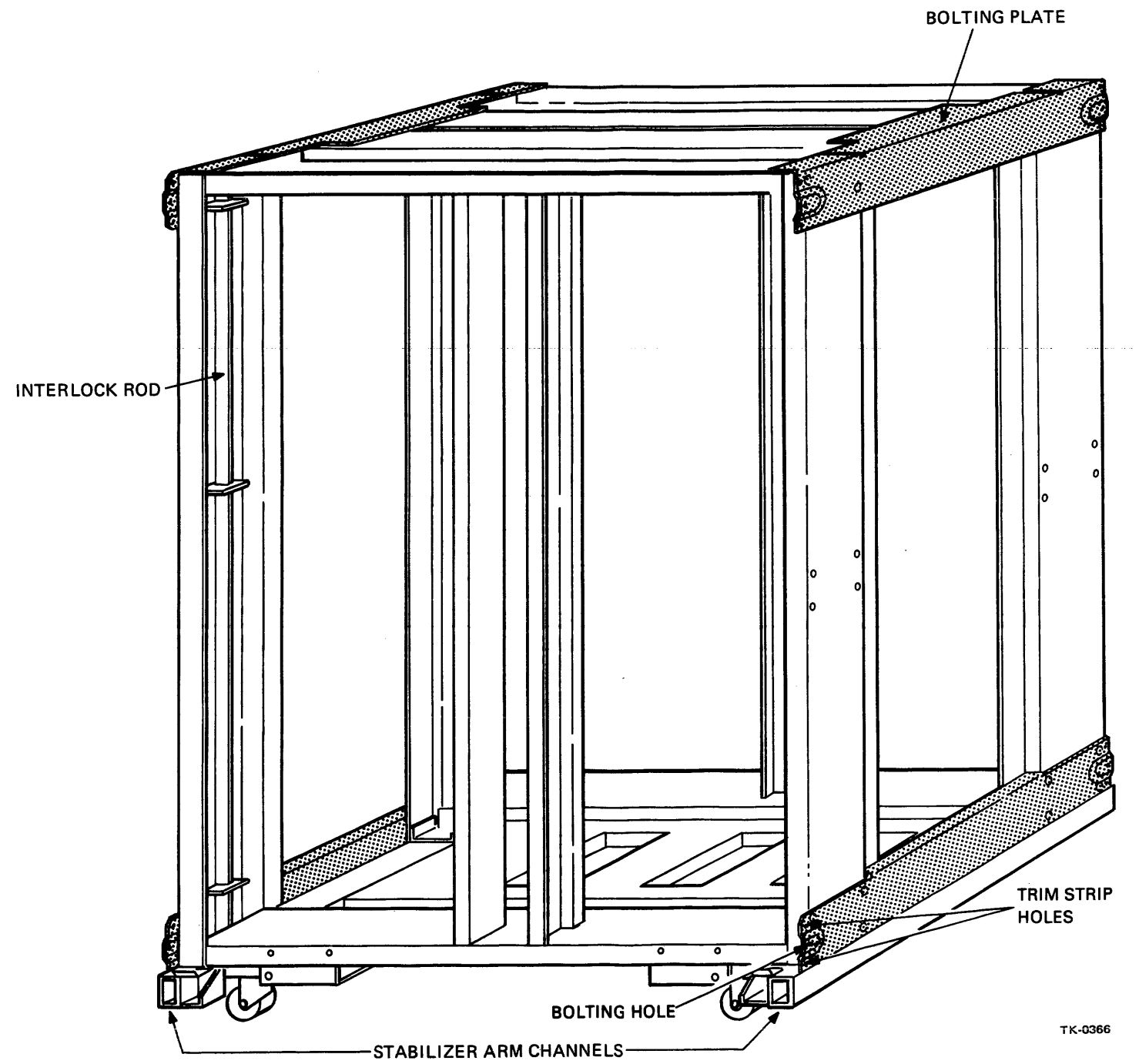

Figure 3-8 Cabinet Frame with Bolting Plates, Stabilizer Channels, and Interlock Rod

11. Remove the shipping clamps from the BA11-K box in the Unibus expander cabinet. If the BA11-K blocks access to trim strip mounting holes, pull out the stabilizer arms and slide out the BA11-K box before mounting the trim strips.
12. Replace the top cover of each cabinet.
13. Connect the ground straps between cabinets.











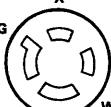

3.7 POWER CHECK

The system cabinet (and the SBI expander cabinet) and the RP05/RP06 disk drives require three-phase ac power. The Unibus expander cabinet and remaining peripheral devices require single-phase ac power.

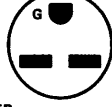
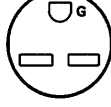
Check the ac power receptacles to ensure that they meet the specifications listed in Table 3-2. Figure 3-9 provides a key to the varieties of receptacles and plugs. When checking the three phase sources, measure the voltage between each of the three-phases and neutral on the receptacles. When checking the single phase sources, measure the voltage between the source and neutral lines on the receptacles.

Table 3-2 AC Power Requirements

Three Phase	Nominal	Minimum	Maximum
Vac	120	100	127
Hz	50	49	61
Hz	60	59	61
Current in amps			20
Vac	240	200	254
Hz	50	49	51
HZ	60	59	61
Current in amps			10
Single Phase (for Unibus expander cabinet)			
Vac	120	90	132
Hz	50	47	63
Hz	60	47	63
Current in amps	12		20
Vac	240	180	264
Hz	50	47	63
Hz	60	47	63
Current in amps	7		10

SOURCE	PLUG	RECEPTACLE	USED ON
120V 15A 1-PHASE	 HUBBEL #5266-C NEMA # 6-15P DEC # 90-08938	 #5262 6-15R 12-05351	ALL 120V TABLE-TOP COMPUTERS. STANDARD 120V LOW-CURRENT DISTRIBUTION. 120V TU10 UNITS. MOST 120V TERMINAL DEVICES.
120V 30A 1-PHASE	 HUBBEL #2811 NEMA # L5-30P DEC # 12-11193	 #2810 L5-30R 12-11194	ALL 120V STANDARD CABINET MOUNTED EOPT
120/208-240V 20A 2-PHASE or 120/208V 20A 3-PHASE Y	 HUBBEL #2411 NEMA # L14-20P DEC # 12-11045	 #2410 L14-20R 12-11046	120V PDP-11/45 PROCESSOR CABINET ONLY.
120/208V 20A 3-PHASE Y	 HUBBEL #2511 NEMA # L21-20P DEC # 12-11209	 #2510 L21-20R 12-11210	60 Hz RM 10 DRUM 60 Hz RP02/RP03/ RP04, RP06, RP06
240V 15A 1-PHASE	 NEMA # 6-15P DEC # 90-08853	 6-15R 12-11204	ALL 240V TABLE-TOP COMPUTERS. STANDARD LOW-CURRENT 240V DISTRIBUTION. MOST 240V TERMINAL DEVICES. 240V TU10.
240V 20A 1-PHASE	 HUBBEL #2321 NEMA # L6-20P DEC # 12-11192	 #2320 L6-20R 12-11191	ALL 240V STANDARD CABINET MOUNTED EQUIPMENT.
240/416V 20A 3-PHASE Y	 NEMA # — NOT NEMA DEC # 12-09010	 NOT NEMA 12-11259	60 Hz RM10 DRUM 60 Hz RP02/RP03/ RP04
120/208V 30A 3-PHASE Y	 HUBBEL #2811 NEMA # L21-30P DEC 12-12314	 #2810 L21-30R 12-12315	PDP11/70 PROCESSOR PDP 11/70 MEM. VAX-11/780 PROCESSOR

TK-0363

Figure 3-9 Varieties of Power Plugs and Receptacles

3.8 INSTALLATION OF THE CONSOLE LA36

1. Cut the nylon retaining straps from around the shipping carton and discard them.
2. Remove the full telescope cap and then remove the stitched tube.
3. Remove all shock-absorbing material and packing from around the LA36 (Figure 3-10).
4. Remove the poly bag from the printer.
5. Remove the foam key protector pad from the keyboard.
6. Loosen and remove the hex head bolt securing the wooden leg brace to the skid assembly. Remove microfoam from around each leg of the LA36.
7. Carefully inspect the LA36 cabinet, keyboard, and carriage assembly for possible shipping damage. Inspect and check the enclosed packing list for lost or missing items. Report any damage or missing items.
8. Lift the LA36 top cover assembly; clip and remove the nylon cable tie securing the print head assembly. Remove the caution tag.
9. Install and adjust the leveling feet on the LA36 legs.
10. Plug the LA36 I/O cable into the H7001 inside the left rear upright of the system cabinet.
11. Reference the installation procedures listed in the *LA36/LA35 DECwriter II User's Manual* (EK-LA3635-OP-003) for further details.

3.9 INTERCABINET CABLING AND INSTALLATION OF PERIPHERAL DEVICES

1. Remove the exhaust plenum at the rear of the system cabinet by loosening two thumb screws at the top corners and lifting off.
2. Untape and uncoil the power cable stored at the bottom rear of the CPU cabinet.

CAUTION

Do not plug the power cable into the customer's ac source until power checks have been completed (Paragraph 3.7).

3. The three-wire DIGITAL power control bus cable is shipped with tie wraps holding it to the front of the Unibus expander cabinet. Connect it from the I/O panel J8 connector at the right end of the system cabinet to the 861 connector* in the Unibus expander cabinet. This connects the 866/869 power controller in the main cabinet with the 861 power controller in the expander cabinet.
4. Connect the remote power sense cable between all 861 power controllers.
5. Plug the three Unibus ribbon cables from the BA11-K box (P2, P1, P3) in the Unibus expander cabinet into the corresponding receptacles (J3, J2, J1) in the CPU cabinet (Figures 3-11 and 3-12).

*Any of three receptacles near the LOCAL ON/REMOTE ON toggle switch.

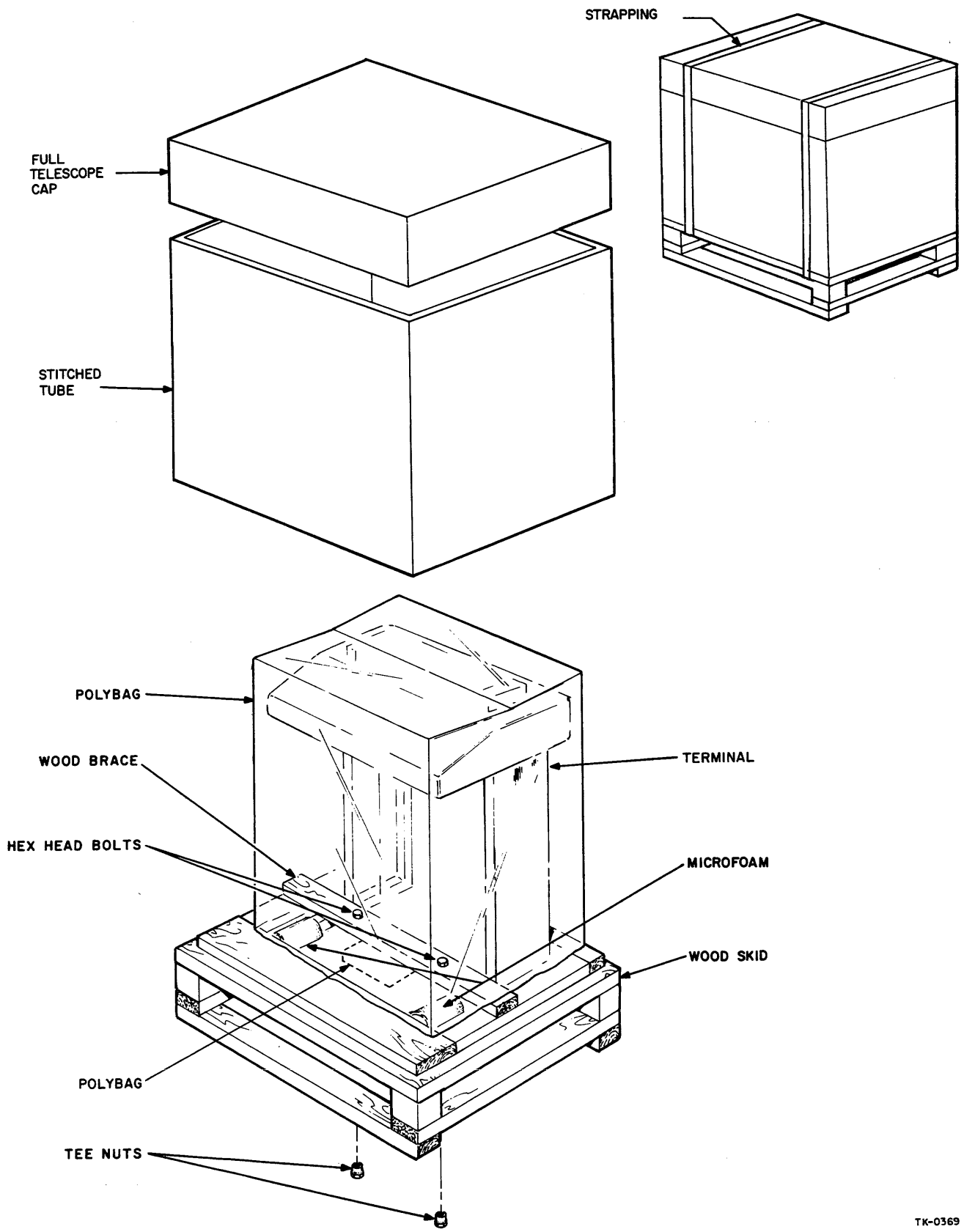
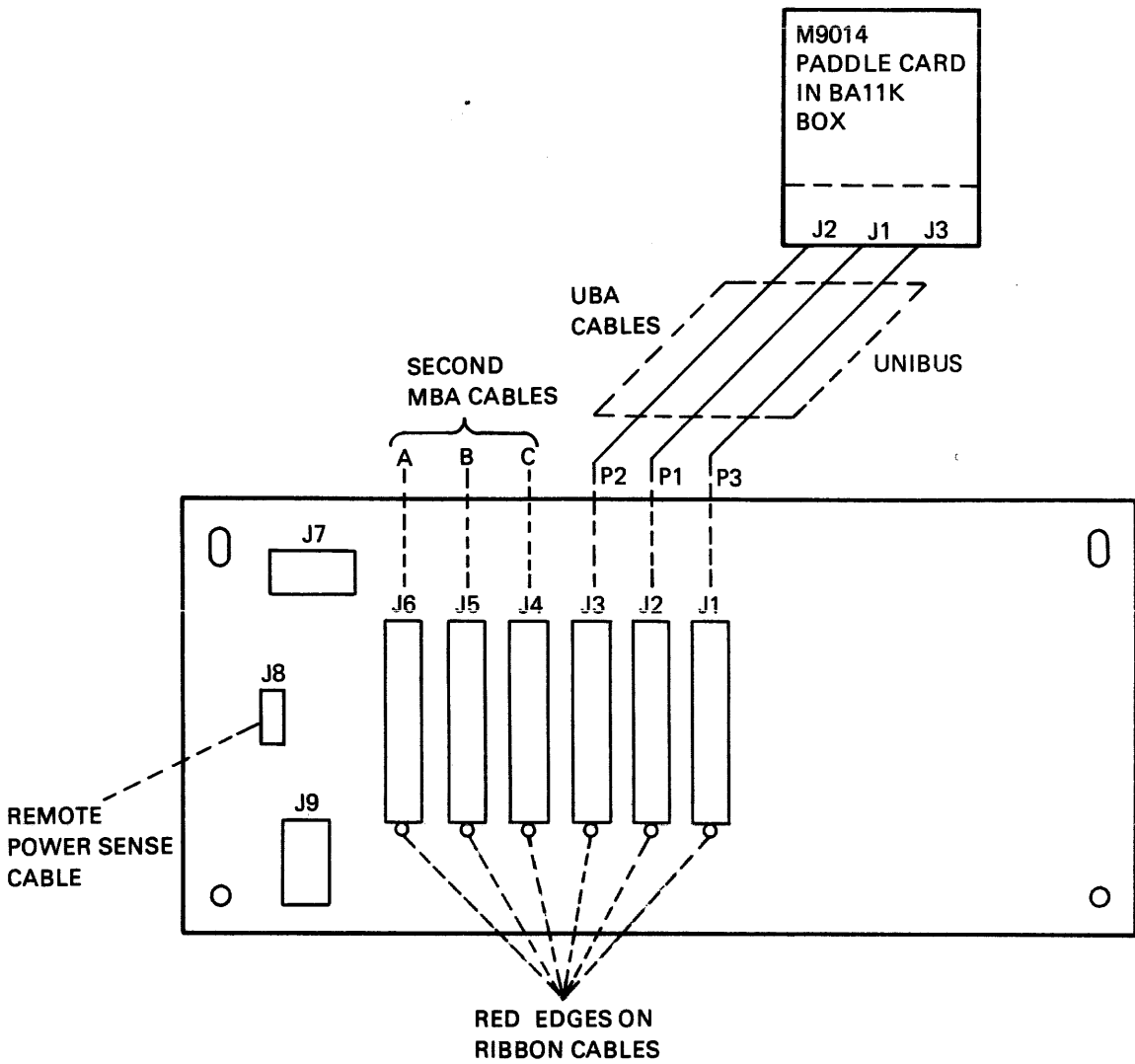

Figure 3-10 LA36 Packaging



TK-0260

Figure 3-11 Unibus Ribbon Cable Connections

6. If a TE16 tape drive is present, connect the I/O cables from the TM03 formatter (Figure 3-13) to J4, J5, J6 of the I/O panel in the system cabinet. Daisy chain the DIGITAL power control bus cable to the 861 power controller. If two or more TE16 tape drives are present, daisy chain the I/O cables. Eight TE16 tape drives can be connected to one TM03 formatter. Refer to the *TE16/TE10W/TE10N DECmagtape Transport Maintenance Manual* (EK-0TE16-TM-001).
7. If an RK06 or RK07 disk drive is present, unpack the unit and attach the I/O cables to the RK611 or RK711 controller in the BA11-K box, according to the instructions listed in the *RK06/RK07 Disk Drive User's Manual* (EK-RK067-UG-001). Route the cables in the Unibus expander cabinet according to the drawing in the Unibus print set.
8. Connect the ground cable between the RK06 and the frame of the Unibus expander cabinet.

NOTE:
 EXAMPLE CABLE ROUTING
 FOR FULL CONFIGURATION.
 DUPLICATE
 CABLING NOT SHOWN.

NOTE: CABLES ARE TO BE CENTERED
 BEHIND BA11-K BOXES WHEN
 PASSING BEHIND THEM. CABLES
 SHOWN SPREAD-OUT FOR
 DRAWING CLARITY ONLY.

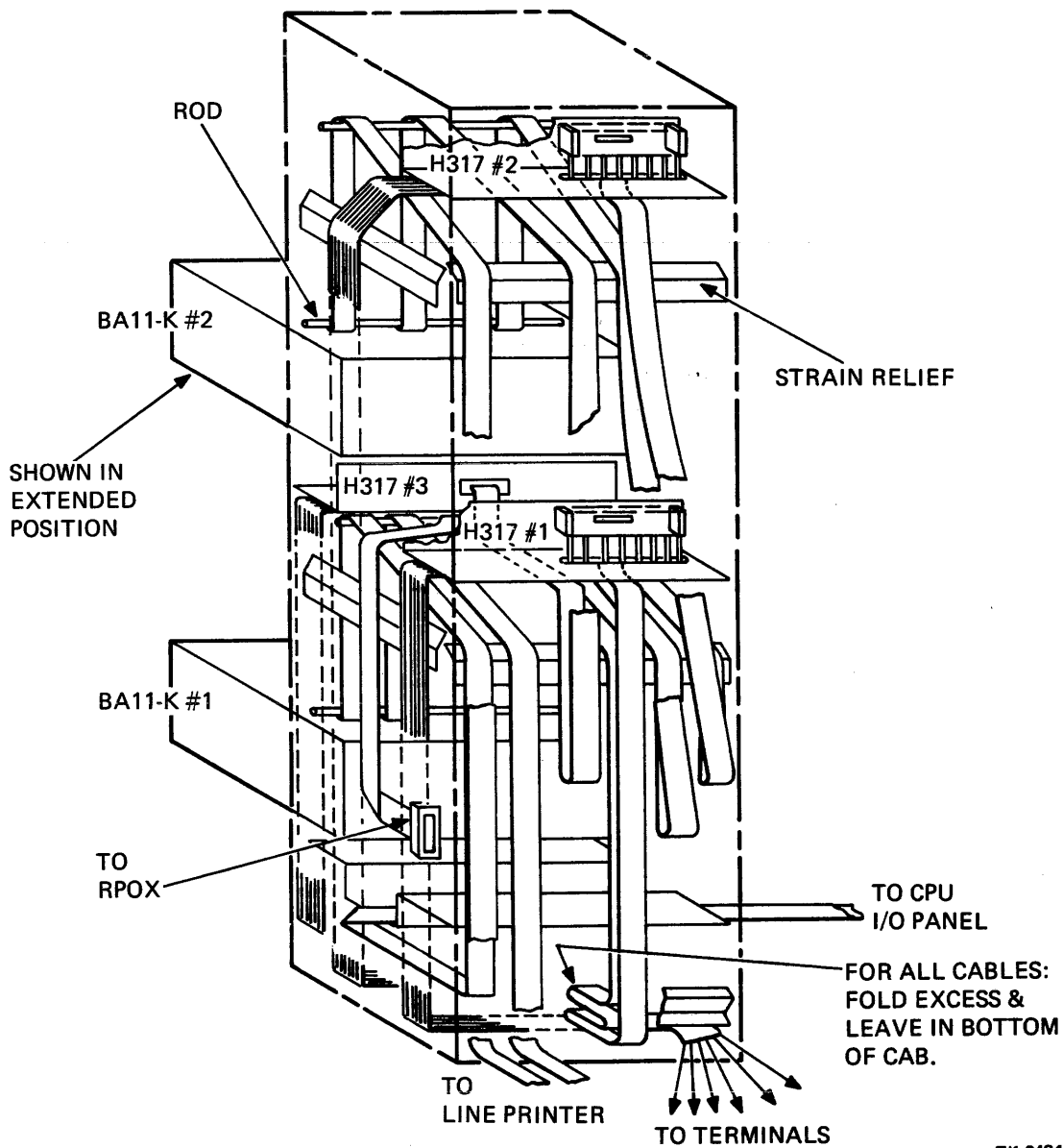

TK-0484

Figure 3-12 Unibus Expander Cabinet,
 Cable Arrangement, Rear View

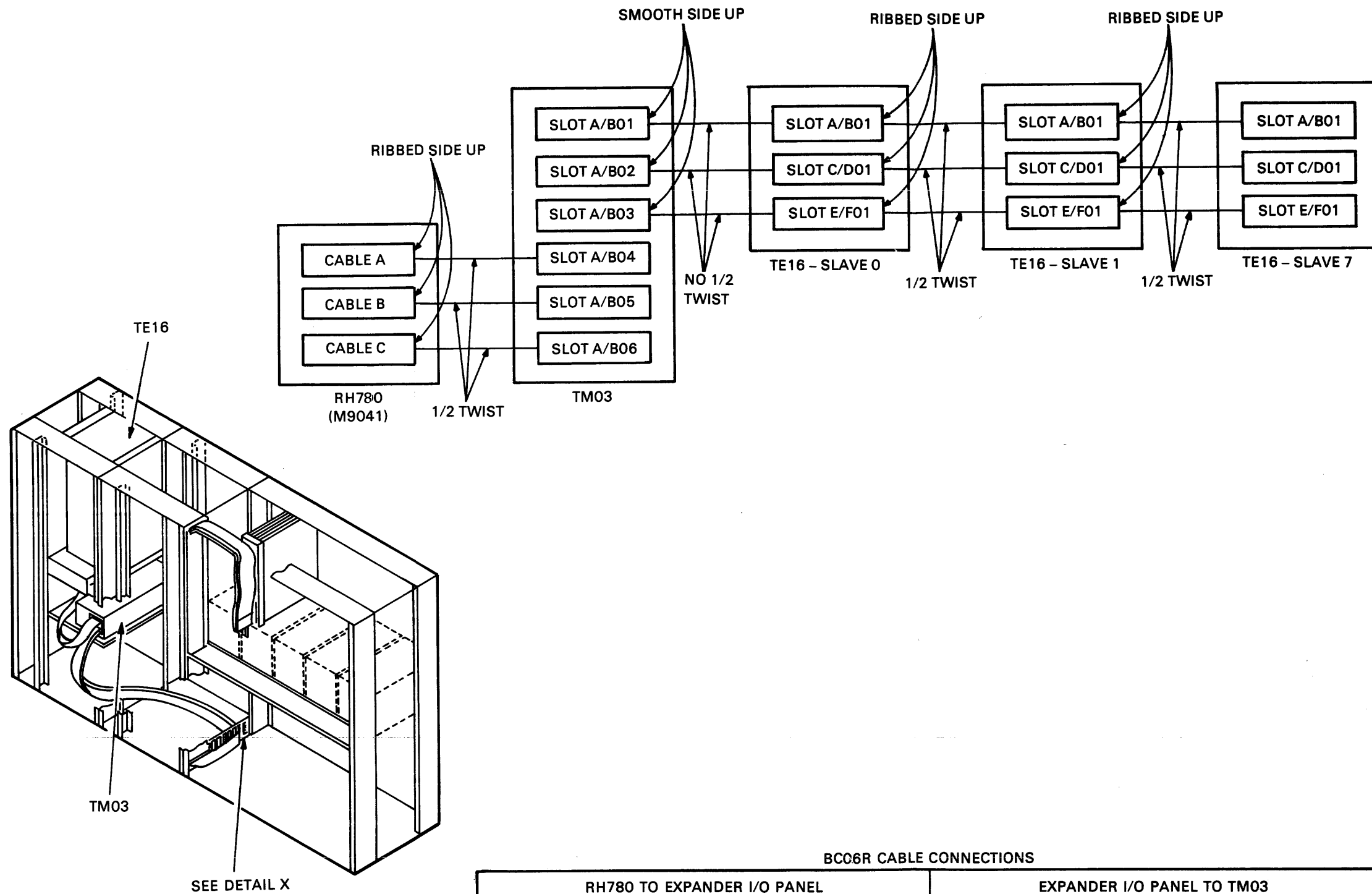

BC06R CABLE CONNECTIONS

RH780 TO EXPANDER I/O PANEL				EXPANDER I/O PANEL TO TM03			
PART NO	DESCRIPTION	FROM	TO	FROM	TO	DESCRIPTION	PART NO
BC06R-10	I/O CABLE	M9041-A	EXP I/O CONN J6	EXP I/O CONN J6	TM03 A/B04	I/O CABLE	BC06R-20
BC06R-10	I/O CABLE	M9041-B	EXP I/O CONN J5	EXP I/O CONN J5	TM03 A/B05	I/O CABLE	BC06R-20
BC06R-10	I/O CABLE	M9041-C	EXP I/O CONN J4	EXP I/O CONN J4	TM03 A/B06	I/O CABLE	BC06R-20

Figure 3-13 TE16 Cable Connections

TK-0264

9. If RP05, RP06, or RM03 disk drives are present, uncrate them and set them up according to procedures outlined in the appropriate installation manuals:
RP05/RP06 Disk Drive Installation Manual (PRELIM) (EK-RP056-IN-PRE)
RM02/RM03 Disk Subsystem Service Manual (EK-RM023-SV-001).
10. Connect the RP05, RP06, or RM03 Massbus cable to the I/O panel J3 in the system cabinet, according to Figure 3-14 or 3-15.
11. Connect the ground wire between the RP05, RP06, or RM03 disk drive and the frame of the system cabinet.
12. If a line printer is present, uncrate it and set it up according to the instructions listed in the *LP11/LS11/LA11 Line Printer Manual (EK-LP11-TM-006)*.
13. Connect the line printer cable that exits from the BA11-K box to the line printer. The cable is round and black (or gray) and labeled no. 70-11 212-0-0.
14. Connect the I/O cables from the supplied terminals to the H317 distribution box in the Unibus expander cabinet, as explained in the *DZ11 User's Guide (EK-DZ110-OP-PRE)*.
15. If a card reader is present, unpack it and set it up according to the instructions listed in the *CR11/CM11 Card Reader System Installation Manual (EK-OCR11-TM-004)*. The I/O cable is round and black, labeled no. 70-08738.
16. If a DR11-B general-purpose interface is installed in a BA11-K box in the Unibus expander cabinet, connections to the user device should be made through the two M957 split lug cable boards that are supplied with the DR11-B option. These M957 boards should be plugged into slot 4, connections C and D, as shown in Figure 3-16. Figure 3-17 shows an M957 board. Note that the test board should be installed in slot 2, connectors A and B, for normal operation and in slot 4, connectors C and D, when running diagnostics. See Chapter 4 of this manual concerning diagnostic procedures; and see the *DR11-B/DA11-B Manual (EK-DR11B-TM-004)* for user device interface information.

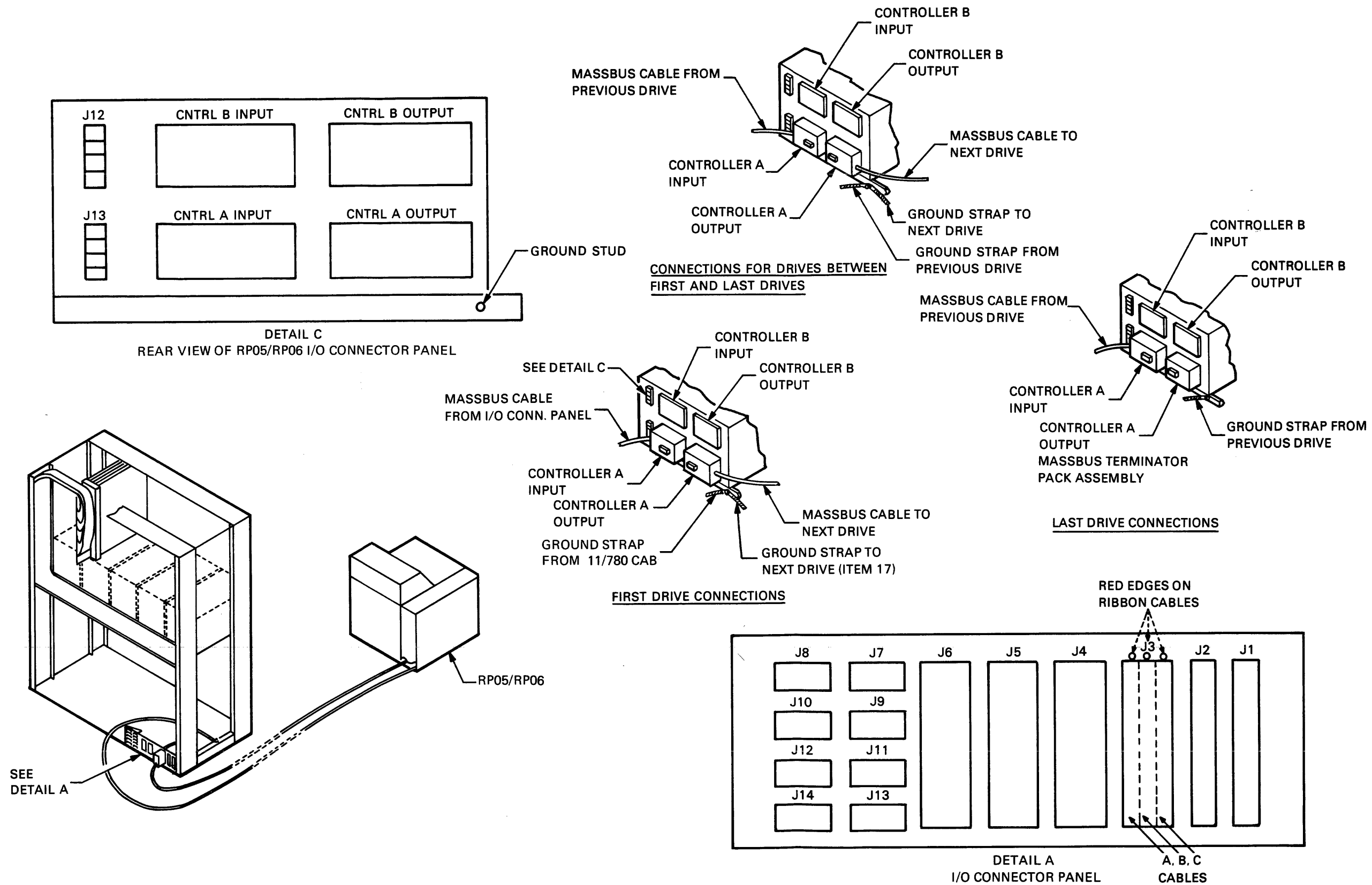
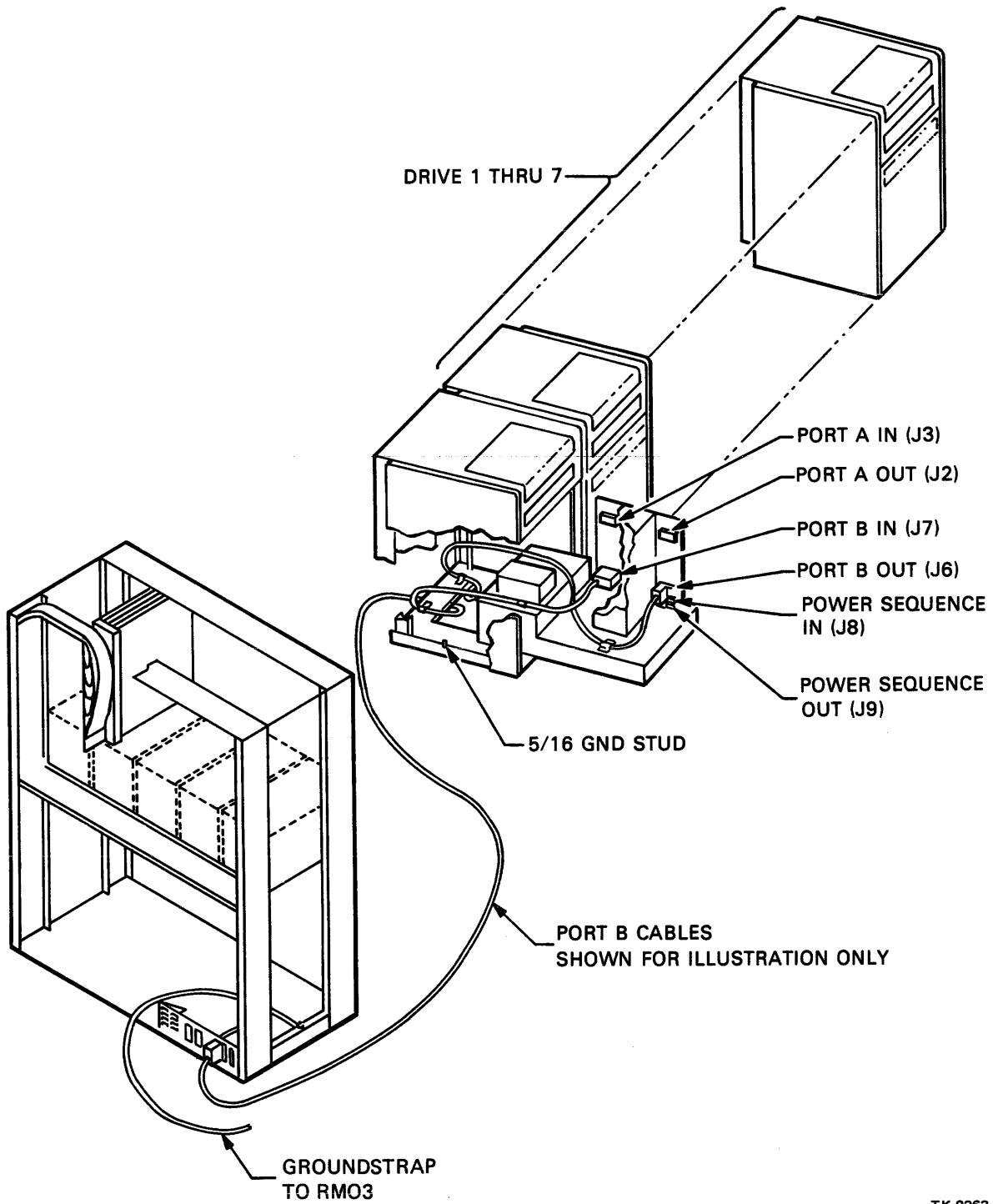

Figure 3-14 RP05/RP06 Cable Connections

TK-0266



TK-0263

Figure 3-15 RM03 Cable Connections

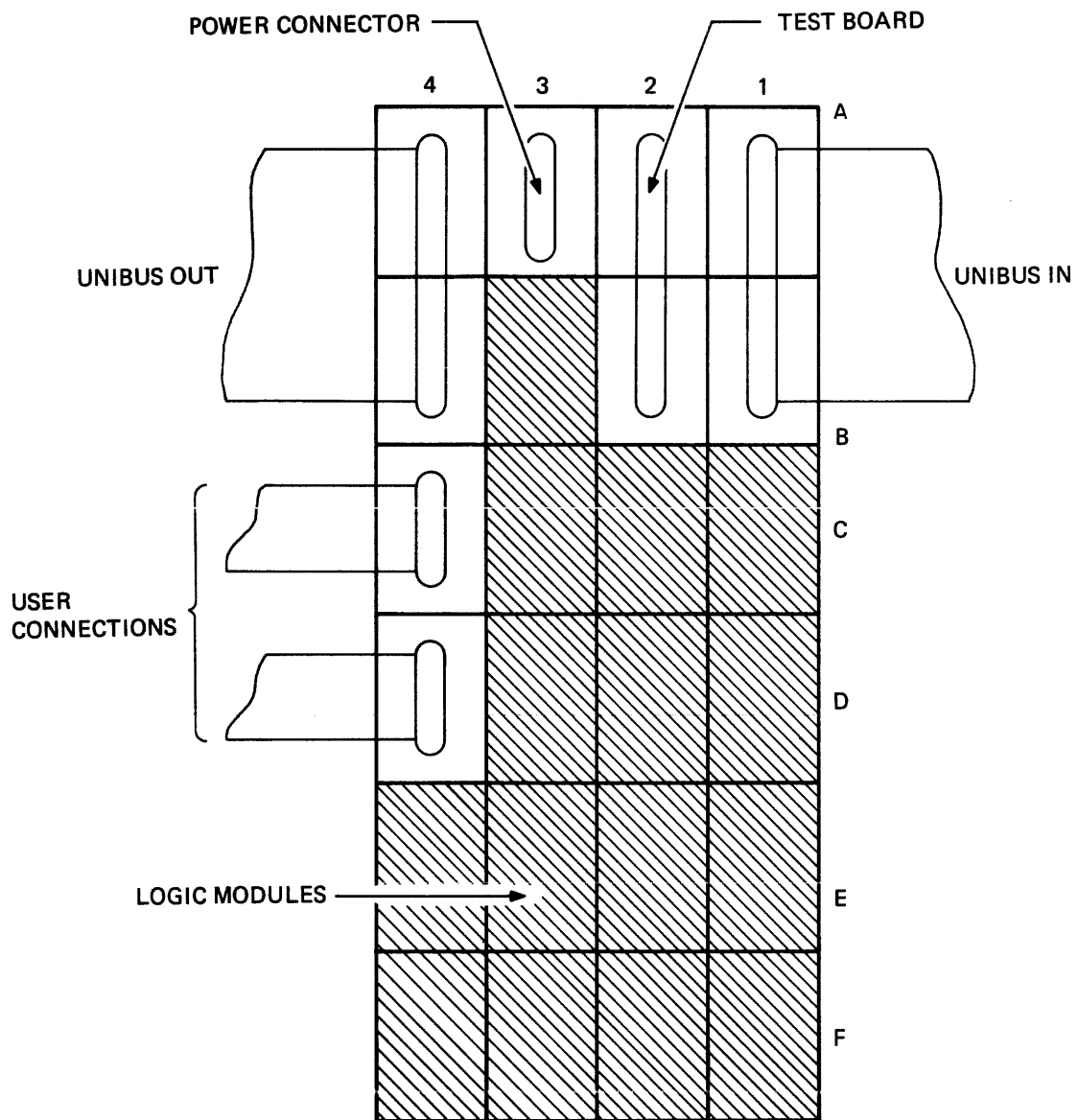

TK-0480

Figure 3-16 DR11-B System Unit Slot Allocation

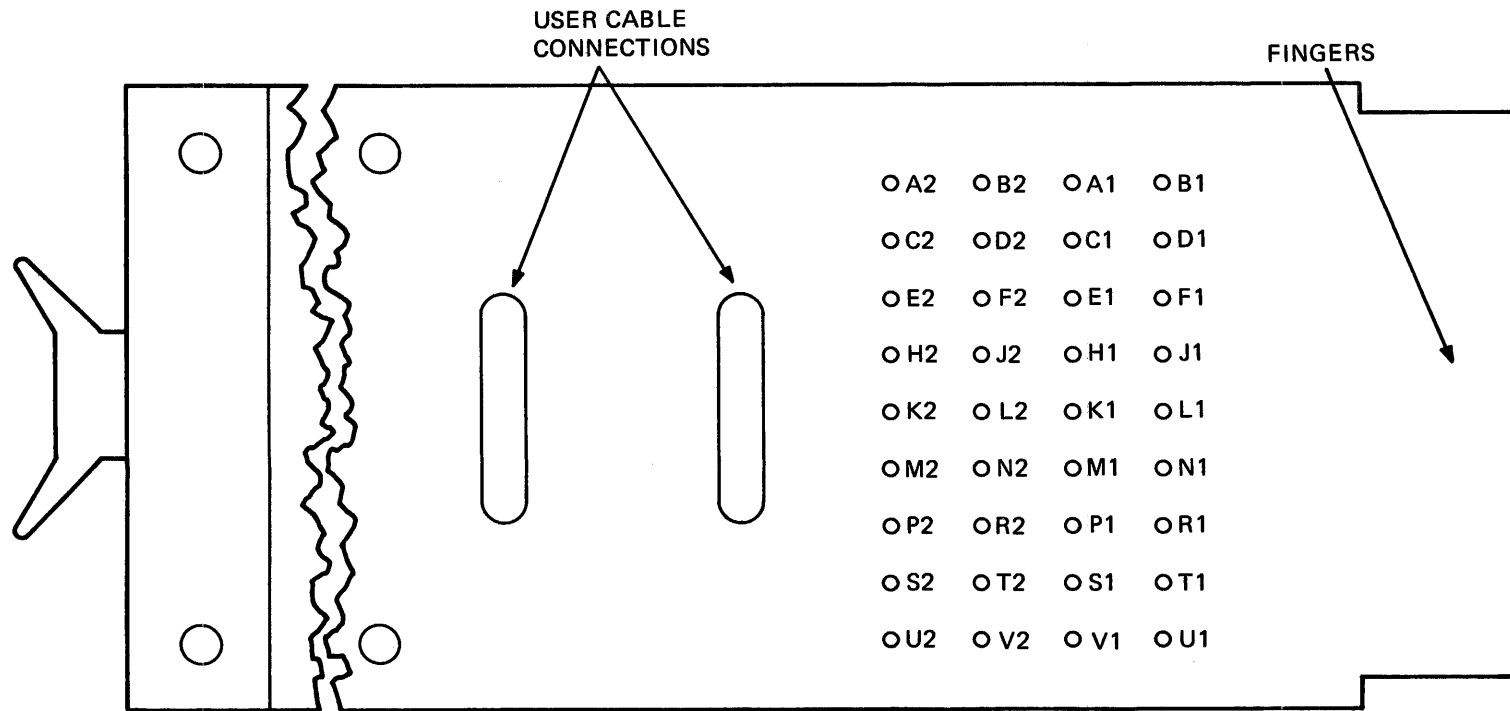

TK-0481

Figure 3-17 M957 Split Lug Cable Board

3.10 SYSTEM START UP PROCEDURE

1. Reinstall doors, tops, and front panels of all cabinets.
2. Level the system using leveler feet. Note that if the system cabinet is not level, the front door will not line up properly.
3. Reinstall the exhaust plenum.
4. Ensure that all circuit breakers in the system, including those in the system power supplies, are OFF.
5. Ensure that the customer power source receptacles are wired properly (Paragraph 3.7).
6. Ensure that all power control sense switches are in the REMOTE position.
7. Ensure that the Auto Restart switch on the control panel (top front of system cabinet) is in the OFF position.
8. Connect the power cable for the system cabinet to the customer power source. Connect the power cable for the Unibus expander cabinet to the customer power source. Connect the power cable for the console LA36 and the other free-standing peripheral devices to the customer power source. Note that the system cabinet (and the SBI expander cabinet) and the P05/RP06 disk drive require three-phase ac power. The Unibus expander cabinet and the remaining peripheral devices require single-phase ac power.
9. Set the main circuit breaker on the power control module to ON (Figure 3-18).
10. Ensure that the memory blower (the one in the middle) is turned ON.
11. Set the three secondary circuit breakers on the 866/869 power control module to ON.
12. Open both front system cabinet doors if they are not already open.
13. See that the memory power supply Power Normal status indicator lamp is lit.
14. Turn on all remaining circuit breakers, including the following:
 - 87111 battery back up circuit breakers
 - 87112 battery back up circuit breakers (if present)
 - 866 circuit breakers in the CPU cabinet and the CPU expander cabinet
 - 861 circuit breakers in the Unibus expander cabinet, the TEE16 cabinet, and the TE16 cabinet
 - all circuit breakers on free-standing peripheral devices
15. Release the drive lock and swing out the floppy drive assembly.
16. Compress the diskette slot cover lock and slide the cover to the right.

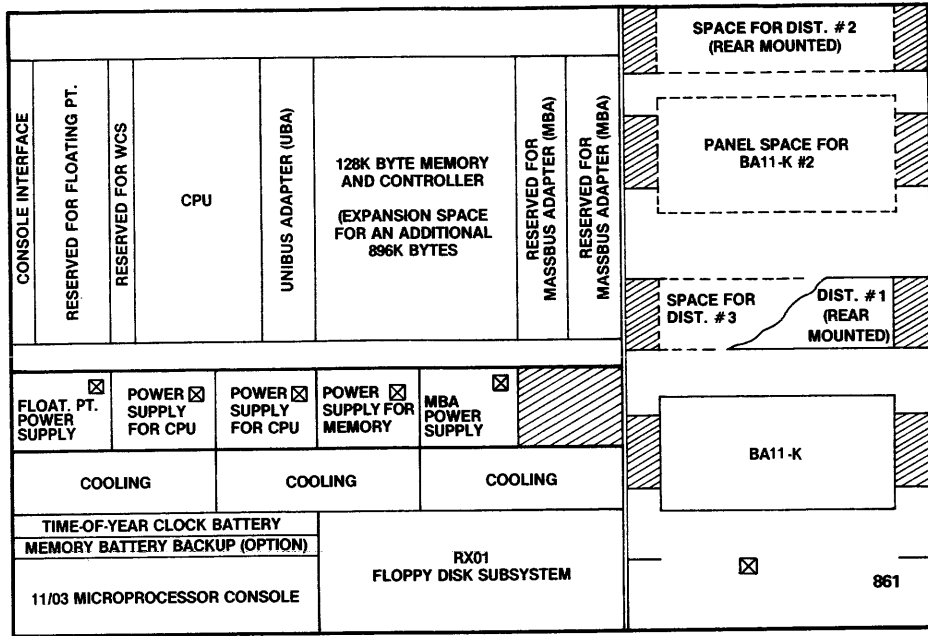

VAX-11 780 SYSTEM CABINET

UNIBUS EXPANSION CABINET

FRONT VIEW

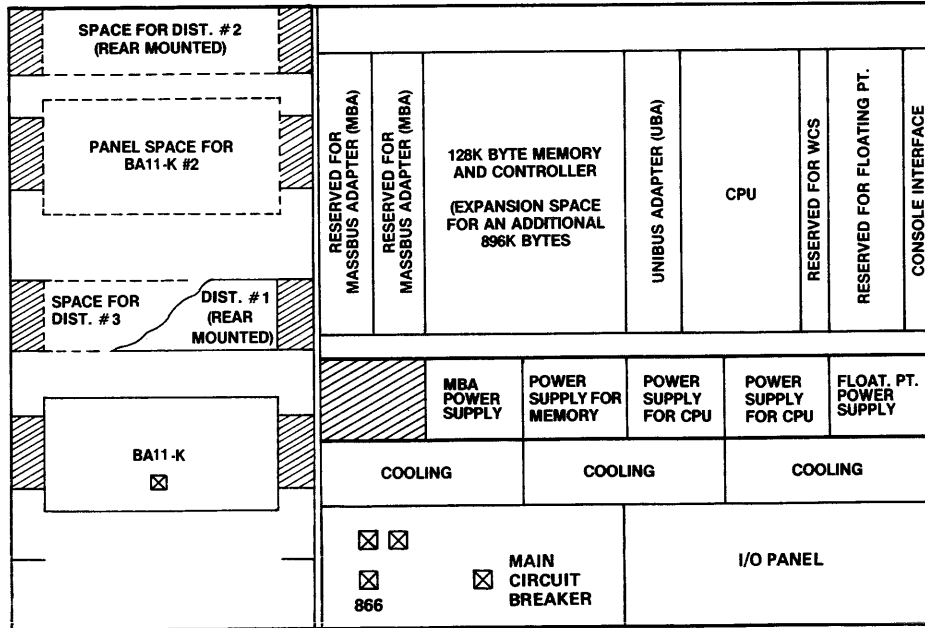

UNIBUS EXPANSION CABINET

VAX-11/780 SYSTEM CABINET

REAR VIEW

TK-0265

Figure 3-18 Circuit Breaker Locations

17. With the diskette label to the right, insert diskette ZZ-ESZAB into the RX01 floppy disk drive and close the cover.
18. Ensure that the LA36 is powered ON. Also see that the LSI-11 HALT/ENABLE switch is set to ENABLE (UP) and that the LSI-11 power switch is set to ON (UP).
19. Set the five-position key switch on the control panel to the LOCAL position.
20. Ensure that the Power Normal indicators on each power supply are lit.
21. Ensure that all blowers are functioning.
22. The power up restart message should be printed on the LA36 console terminal.

Console terminal output:

```
CPU HALTED, SOMM CLEAR, STEP=NONE, CLOCK=NORM  
RAD=HEX, ADD=PHYS, DAT=LONG, FILL=00, REL=00000000  
INIT SEQ DONE  
HALTED AT 00000000
```

```
(RELOADING WCS)  
LOAD DONE, 00003200 BYTES LOADED  
VER: PCS=01 WCS=03-10 FLPA=03 CON=PX03-08
```

23. Set all remaining circuit breakers on power controllers, expander boxes, and peripherals to ON.

CHAPTER 4

SYSTEM CHECKOUT AND ACCEPTANCE

4.1 GENERAL

Perform system checkout and acceptance by running the following diagnostic programs and booting the operating system in the order specified below.

- Microdiagnostics on floppy disk 1 (diskette ZZ-ESZAC)
- Microdiagnostics on floppy disk 2 (diskette ZZ-ESZAD)
- CPU Cluster Exerciser (ESKAX, ESKAY, ESKAZ)
- Tape Drive Functional Timer (ESMAB)
Run Time: 3 min/drive
- RPOX Functional Test (ESRBA)
Run Time: 10 min/drive
- DMC11 Exerciser (ESDDBB)
Run Time: 2 seconds
- Boot VMS
- Tape Drive Reliability Test (ESMAA)
Run Time: 15 min/drive
- Disk Formatter (ESRAB)
Run Time: 2 min/RK06
5 min/RP04/05
8 min/RP06
- Disk Reliability Test (ESRAA)
Run Time: Multidrive test - indefinite
- Multiterminal Diagnostic (ESTBA)
Run Time: 3-30 min
- Local Terminal Diagnostic (ESTAA)
Run Time: 3-30 min
- Line Printer Diagnostic (ESAAA)
Run Time: 3-15 min/printer

- System Exerciser (acceptance mode, ESXBA)
Run Time: 15 min, typical
- User Environment Test Package (UETP)

The VAX-11/780 system is ready for acceptance when each of the above diagnostic programs has been run with at least one error-free pass. Note that each command line should be terminated by a carriage return. Note also that a colon (:) should follow the device mnemonic when the device is selected for testing.

4.2 MICRODIAGNOSTICS

Run one pass.

Run Time: diskette 1, 5-8 min; diskette 2, 4-30 min

1. Insert diskette 1 (ZZ-ESZAC) in the floppy disk drive.
2. Type Control P to enter the console I/O mode.
3. Type HALT to halt the VAX-11/780 CPU. The ATTN light on the console panel should light and the prompt symbol, >>>, should be printed out on the console terminal.
4. Type I to initialize the system.
5. Type TEST to start the microdiagnostic program.
6. Microdiagnostic monitor and programs are loaded.
7. Console outputs microdiagnostic section number when a test begins executing.
8. Console terminal output will look like this:

```
>>> TEST
ZZ-ESKAB V8.0
01,02,03,04
NO. OF WCS MODULES = 0002
05,06,07,08,09,0A,0B,0C,0D,0E,0F,10,11,12,13,14,15,16,17,18,19,1A,
1B,1C,1D,1E,1F,20,21,22,23,24,25,26,27,28,29,2A,2B,2C,2D,2E,2F,30,
31,32,33,34,35,36,37,38,39,3A,3B,3C,3D,
END PASS 0001
MOUNT FLOPPY ZZ-ESZAD & TYPE "DI"
MIC>
```

- ^ The microdiagnostic identifies itself, its release level and size.
- ^ The terminal prints out section numbers. Should test execution terminate, the operator knows which section failed.

NOTE

Operator input is underlined.

9. At end of pass, the console directs the operator to insert the next diskette and type DI (diagnose).

10. The microdiagnostic monitor then prompts for operator input.
11. Insert diskette ZZ-ESZAD.
12. After inserting the required diskette, type DI.
13. Programs resident on diskette ZZ-ESZAD are then executed.
14. Console terminal output:

```

MIC > DI
3E,
# MEM CTRLS = 00000001
3F,40,
4K CHIP 00001008
41,42,
CPU TR = 00000010
43,44,45,46,47,48,49,4A,4B,4C,4D,
CTRL 1 MAX ADR+1 = 00090000
4E,
CTRL 1 MAX ADR+1 = 00090000
4F,50,
STARTING FPA TESTS
51,52,53,54,55,56,57,58,59,5A,5B,
END PASS 0001

      CPU HALTED,SOMM CLEAR,STEP=NONE,CLOCK=NORM
      RAD=HEX,ADD=PHYS,DAT=LONG,FILL=00,REL=00000000
      INIT SEQ DONE
      HALTED AT 00000000

      (RELOADING WCS)
      LOAD DONE, 00003200 BYTES LOADED
      VER: PCS=01 WCS=03-10 FPLA=03 CON=PX03-08

>>>

^ Note that microdiagnostic section numbers are sequential
  (Hex).

^ End of pass indication is printed when test execution is
  completed.

^ Note that the diagnostic monitor reloads WCS and then
  returns control to the console program.

^ The console program puts out a prompt character, >>>.

```

4.3 LOADING THE DIAGNOSTIC SUPERVISOR (ESSAA) DIRECTLY

The diagnostic supervisor is required to execute macro level diagnostic programs. Proceed as follows.

1. Type Control P to return control to the console program.
2. Type HALT to halt the CPU.
3. Install diskette ZZ-ESZAF.

4. Console prompts for input.
5. Load the diagnostic supervisor into the main memory by typing - LO ESSAA.EXE/ST:FE00.
6. Console terminal output:

```

>>> LO ESSAA.EXE/ST:FE00
      LOAD DONE, 0000A000 BYTES LOADED

^ Console program prompts for input.
^ Operator types supervisor file name and load start
  address.
^ Output specifies load size.

```

4.4 INDIRECT CONSOLE COMMAND FILES

The user may load the diagnostic supervisor, load a diagnostic program, and start the diagnostic supervisor by executing an indirect command file. Proceed as follows.

1. Type Control P to return control to the console program.
2. Type @<code>, where <code> is the five-letter mnemonic designation for the diagnostic program to be loaded.

Console terminal output:

```

>>>@ESKAZ

HALT      ! HALT THE CPU

          CPU HALTED
INIT      ! INITIALIZE

          INIT SEQ DONE
UNJAM     ! AND CLEAR THE SBI

LO ESKAZ.EXE/ST:200

          LOAD DONE, 0000CE00 BYTES LOADED
!         MEMORY MANAGEMENT AND PDP-11 COMPATIBILITY

LO ESSAA.EXE/ST:FE00

          LOAD DONE, 0000D000 BYTES LOADED
START 10000

<@EOF>
<@EXIT>

DIAGNOSTIC SUPERVISOR. ZZ-ESSAA-4.02-417 6-JUN-1978 08:46:12.9

DS>

```

At this point, type ST to start the diagnostic program.

4.5 CPU CLUSTER EXERCISER PACKAGE

Three programs (ESKAX, ESKAY, and ESKAZ) make up the CPU cluster exerciser package. Run one pass of each program.

ESKAX (Quick Verify Portion of the CPU Cluster Exerciser)

Load and run ESKAX as follows.

1. Type Control P to return control to the console program. Insert diskette ZZ-ESZAF.
2. Type @ESKAX to load the program and load and start the supervisor.
3. Type ST to start the program.
4. Select the CPU (KA), UBA (DW), and MBA (RH0) for testing as follows.

SELECT UNITS: KA0:, DW0:, RH0:
5. Supply the requested information for each device to be tested, as in the example below.
6. Console terminal output:

```
>>>@ESKAX

HALT      ! HALT THE CPU

          CPU HALTED
INIT      ! INITIALIZE

          INIT SEQ DONE
UNJAM     ! AND CLEAR THE SBI

LO ESKAX.EXE/ST:200

          LOAD DONE, 0000DC00 BYTES LOADED
!         QUICK VERIFY

LO ESSAA.EXE/ST:FE00

          LOAD DONE, 0000D000 BYTES LOADED
START 10000

<@EOF>
<@EXIT>

DIAGNOSTIC SUPERVISOR. ZZ-ESSAA-4.02-417 6-JUN-1978 08:39:21.31

DS> ST

PROGRAM: CPU CLUSTER EXERCISER, REV 9 DEPO 0, 4 TESTS.

***** SIZER NOT YET IMPLEMENTED *****

SELECT UNITS: KA0:, DW0:, RH0:

FOR DEVICE: KA0
ENTER TR NUMBER [1-16(D)]: 16
```

```
FOR DEVICE: DWO
ENTER TR NUMBER [1-16(D)]: 3
ENTER ADAPTER BR LEV [4-7(D)]: 4
ENTER DEVICE BR LEVEL [4-7(D)]: 4
ENTER UBA NUMBER [0-3(D)]: 0
ENTER UNIBUS DEVICE ADDRESS [00000760000-0000077776(0)]: 770000
```

```
FOR DEVICE: RHO
ENTER TR NUMBER [1-16(D)]: 8
ENTER ADAPTER BR LEVEL [4-7(D)]: 5
```

```
NUMBER OF NEXUS FOUND: 00000002
```

NEXUS ADD	TR LVL	TYPE
20012000	00000009	RHn
20001000	00000008	RHn
20006000	00000003	DWn

```
NUMBER OF DWX'S FOUND: 00000001
```

NEXUS ADD	REG ADD
60006000	2013F000

```
NUMBER OF MBE'S FOUND 00000000
```

```
END OF RUN, 1 PASSES. 0 ERRORS DETECTED, TIME: 6-JUN-1978
08:40:57.88
```

```
DS>
```

7. Run ESKAY, the native instruction portion of the cluster exerciser, by typing @ESKAY and supplying the information requested.
8. Console terminal output:

```
>>>@ESKAY
```

```
HALT ! HALT THE CPU
```

```
CPU HALTED
INIT ! INITIALIZE
```

```
INIT SEQ DONE
UNJAM ! AND CLEAR THE SBI
```

```
LO ESKAY.EXE/ST:200
```

```
LOAD DONE, 0000AA00 BYTES LOADED
! NATIVE INSTRUCTION TESTS
```

```
LO ESSAA.EXE/ST:FE00
```

```
LOAD DONE, 0000D000 BYTES LOADED
START 10000
```

```
<@EOF>
<@EXIT>
```

```
DIAGNOSTIC SUPERVISOR. ZZ-ESSAA-4.02-417 6-JUN-1978 08:48:13.86
```

```

DS> ST

PROGRAM: CPU CLUSTER EXERCISER, REV 9, DEPO 0, 10 TESTS.

***** SIZER NOT YET IMPLEMENTED *****

SELECT UNITS: KA0:, DW0:, RH0:

FOR DEVICE: KAO
  ENTER TR NUMBER [1016(D)]: 16

FOR DEVICE: DW0
  ENTER TR NUMBER [1-16(D)]: 3
  ENTER ADAPTER BR LEV [4-7(D)]: 4
  ENTER DEVICE BR LEVEL [4-7(D)]: 4
  ENTER UBA NUMBER [0-3(D)]: 0
  ENTER UNIBUS DEVICE ADDRESS [00000760000-00000777776(0)]: 770000

FOR DEVICE: RH0
  ENTER TR NUMBER [1-16(D)]: 8
  ENTER ADAPTER BR LEVEL [4-7(D)]: 5

END OF RUN, 1 PASSES. 0 ERRORS DETECTED, TIME: 6-JUN-1978
08:46:34.27

DS>

```

9. Run ESKAZ, the memory management and PDP-11 compatibility portion of the cluster exerciser, by typing @ESKAZ and supplying the information requested.
10. Console terminal output:

```

>>>@ESKAZ

HALT      ! HALT THE CPU

          CPU HALTED
INIT      ! INITIALIZE

          INIT SEQ DONE
UNJAM     ! AND CLEAR THE SBI

LO ESKAZ.EXE/ST:200

          LOAD DONE, 0000CE00 BYTES LOADED
!         MEMORY MANAGEMENT AND PDP-11 COMPATABILITY

LO ESSAA.EXE/ST:FE00

          LOAD DONE, 0000D000 BYTES LOADED
START 10000

<@EOF>
<@EXIT>

DIAGNOSTIC SUPERVISOR. ZZ-ESSAA-4.02-417 6-JUN-1978 08:46:12.19

DS> ST

```

```

PROGRAM: CPU CLUSTER EXERCISER, REV 9, DEPO 0, 2 TESTS.
***** SIZER NOT YET IMPLEMENTED *****
SELECT UNITS: KAO:, DWO:, RHO:

FOR DEVICE: KAO
  ENTER TR NUMBER [1-16(D)]: 16

FOR DEVICE: DWO
  ENTER TR NUMBER [1-16(D)]: 3
  ENTER ADAPTER BR LEV [4-7(D)]: 4
  ENTER DEVICE BR LEVEL [4-7(D)]: 4
  ENTER UBA NUMBER [0-3(D)]: 0
  ENTER UNIBUS DEVICE ADDRESS [00000760000-00000777776(0)]: 770000

FOR DEVICE: RHO
  ENTER TR NUMBER [1-16(D)]: 8
  ENTER ADAPTER BR LEVEL [4-7(D)]: 5

END OF RUN, 1 PASSES. 0 ERRORS DETECTED, TIME: 6-JUN-1978
08:46:34.27

DS>

```

4.6 TAPE DRIVE FUNCTIONAL TIMER (ESMAB)

Run one pass.

Run Time: 3 min/drive.

1. Type Control P to return control to the console program.
2. Type HALT to halt the CPU.
3. Insert diskette ZZ-ESZ2A.
4. Type LO ESSAA.EXE/ST:FE00 to load the diagnostic supervisor.
5. Type LO ESMAB.EXE/ST:200 to load the drive functional timer.
6. Type ST 10000 to start the diagnostic supervisor.
7. Mount a scratch tape in each tape drive unit to be tested.
8. Type ST to run section 1, the default section.

9. The program starts up, identifies itself, and asks the operator for the unit to be tested. Select the unit or units to be tested by typing the device mnemonic, e.g., MTA0.

Console terminal output:

```

>>>LO ESSAA.EXE/ST:FE00
      LOAD DONE, 00009E00 BYTES LOADED
>>>LO ESMAB.EXE/ST:200
      LOAD DONE, 00004200 BYTES LOADED
>>>ST 10000
DIAGNOSTIC SUPERVISOR.  ZZ-ESSAA-3.05-203 14-DEC-1977 14:10:59.99
DS>ST
PROGRAM: ZZ-ESMAB-1.0 TM03-TE16 DRIVE FUNCTION TIMER, REV 0, DEPO
0.
***** SIZER NOT YET IMPLEMENTED *****
SELECT UNITS:  MTA0:
FOR DEVICE:  MTA0
      ENTER TR NUMBER [1-16(D)]:  9
      ENTER ADAPTER BR LEVEL [4-7(D)]:  5

*****
TM03 DRIVE FUNCTION TIMES: DRIVE # 0 SLAVE #0 TE16 SERIAL # 6781
*
* FUNCTION                TIME (SPECIFICATION)      TIME (ACTUAL)
* T1.  WRITE FROM BOT      RANGE: 154000-150000     ACTUAL: 151480
* T2.  WRITE START         RANGE: 9500-8700         ACTUAL: 9016
* T3.  WRITE SHUTDOWN      RANGE: 8500-7500         ACTUAL: 8064
* T4.  WRITE SETTLEDOWN    RANGE: 13500-7300        ACTUAL: 10080
* T5.  READ FROM BOT       RANGE: 37000-33000        ACTUAL: 35000
* T6.  READ START          RANGE: 3200-2400         ACTUAL: 2744
* T7.  READ SHUTDOWN       RANGE: 4100-3000         ACTUAL: 3752
* T8.  READ SETTLEDOWN     RANGE: 13500-7300        ACTUAL: 10080
* T9.  READ REV STRT       RANGE: 3200-2400         ACTUAL: 2744
* T10. READ REV SHTDWN     RANGE: 3700-3300         ACTUAL: 3472
* T11. READ REV STTLDWN    RANGE: 13500-7300        ACTUAL: 10080
* T12. TRN ARND DLY F-R    RANGE: 16700-10700       ACTUAL: 12096
* T13. TRN ARND DLY R-F    RANGE: 16700-10700       ACTUAL: 12096
* T14. GAP: STOP HALF      RANGE: 12900-9500        ACTUAL: 10696
* T15. GAP: STRT HALF      RANGE: 11800-8500        ACTUAL: 9632
* T16. GAP: INTERRCORD     RANGE: 14300-12600       ACTUAL: 13776
* T17. GAP: CONSISTENCY    RANGE: 13500-11800       ACTUAL: 12376
* T18. DATA: 800 BPI      RANGE: 24000-22000       ACTUAL: 23408
* T19. DATA: 1600 BPI     RANGE: 25100-24100       ACTUAL: 24472
* T20. ERASE TIME         RANGE: 101000-98000      ACTUAL: 99512
* T21. WRITE FILE MARK     RANGE: 104000-102000     ACTUAL: 103096
GAP TIMES FOR TEST 17 (GAP CONSISTENCY TEST)
* GAP #: 0                 RANGE: 13800-12600       ACTUAL: 13328
* GAP #: 1                 RANGE: 14500-13500       ACTUAL: 13888
* GAP #: 2                 RANGE: 14900-13500       ACTUAL: 13664
* GAP #: 3                 RANGE: 14800-13400       ACTUAL: 13272

```

* GAP #:	4	RANGE: 14000-12000	ACTUAL: 12376
* GAP #:	5	RANGE: 13900-11000	ACTUAL: 12096
* GAP #:	6	RANGE: 13700-11000	ACTUAL: 11872
* GAP #:	7	RANGE: 13700-11500	ACTUAL: 12096
* GAP #:	8	RANGE: 13500-11500	ACTUAL: 11984
* GAP #:	9	RANGE: 13400-11500	ACTUAL: 12040
* GAP #:	10	RANGE: 13400-11500	ACTUAL: 11928
* GAP #:	11	RANGE: 13400-11500	ACTUAL: 11984
* GAP #:	12	RANGE: 13400-11500	ACTUAL: 12152
* GAP #:	13	RANGE: 13400-11500	ACTUAL: 11872
* GAP #:	14	RANGE: 13400-11500	ACTUAL: 11928
* GAP #:	15	RANGE: 13400-11500	ACTUAL: 11984

END OF RUN, 1 PASSES. 0 ERRORS DETECTED, TIME: 14-DEC-1977
14:10:59.99
DS>

10. On completion of this test, control returns to the diagnostic supervisor. Mount a pre-formatted head alignment tape (part no. 29-22020) on each tape drive to be tested.
11. Type ST/SEC:SPEED to run the speed section of the program.
12. The program starts up, identifies itself, and asks the operator for the unit to be tested.

Save output for future reference when doing PMs.

4.7 RPOX FUNCTIONAL DIAGNOSTIC (ESRBA)

Run one pass.

Run Time: 1 min

1. Type Control P to return control to the console program.
2. Type HALT to halt the CPU.
3. Install diskette ZZ-ESZ1A.
4. Load the diagnostic supervisor if it is not already loaded.
5. Type LO ESRBA.EXE/ST:200 to load the RPOX functional test.
6. Type ST 10000 to start the diagnostic supervisor. The diagnostic supervisor prompts for input.
7. Type ST to start the RPOX functional diagnostic program.
8. The RPOX functional diagnostic starts up, identifies itself, and asks for the units to be tested (e.g., DB2:), the TR number (8), and the adapter BR level (5).

Save output for future reference when doing PMs.

9. Console terminal output:

```
DS>
>>> HALT

      HALTED AT 00014FEA

>>> LO ESRBA.EXE/ST:200

      LOAD DONE, 0000DA00 BYTES LOADED

>>> ST 10000

DIAGNOSTIC SUPERVISOR. ZZ-ESSAA-3.05-203 14-DEC-1977 14:10:59.99

DS> ST

PROGRAM: ZZ-ESRBA-1.0 RPOX FUNCTIONAL DIAGNOSTIC, REV 0, DEPO 0.

***** SIZER NOT YET IMPLEMENTED *****

SELECT UNITS: DB2:

FOR DEVICE: DB2
      ENTER TR NUMBER [1-16(D)]: 8

      ENTER ADAPTER BR LEVEL [4-7(D)]: 5

VOLUME MOUNTED ON DB2 FAILED ID CHECK
EXPECTED: "'SCRATCH' ; ACTUAL: "
DO YOU WANT TO CONTINUE THE TEST [(N), Y OR N]: Y

TIMING TESTS ON DB2

PACK SPEED (EXPECTED) = 16.67 MS. [+/- 2%(60HZ), +/- 2.5%(50HZ)]
PACK SPEED (ACTUAL)   = 17.11

FORWARD (1 CYL) SEEK TIME = 5.99MS.
REVERSE (1 CYL) SEEK TIME = 6.44MS.
AVERAGE (1 CYL) SEEK TIME = 6.22MS.

FORWARD ACCESS TIME = 29.14MS.
REVERSE ACCESS TIME = 29.07MS.
AVERAGE ACCESS TIME = 29.10MS.

MAXIMUM FORWARD SEEK TIME = 52.89MS.
MAXIMUM REVERSE SEEK TIME = 50.75MS.
MAXIMUM AVERAGE SEEK TIME = 51.82MS.

SUMMARY SECTION NOT IMPLEMENTED IN THIS DIAGNOSTIC

END OF RUN, 1 PASSES. 0 ERRORS DETECTED, TIME: 14-DEC-1977
14:10:59.99

DS>
```

4.8 DMC EXERCISER (ESDBB)

Run one pass.

Run Time: 2 seconds

1. Insert diskette ZZ-ESZ3A.
2. Type Control P to return to the console program and HALT to halt the VAX-11/780 CPU.
3. Load the diagnostic supervisor if it is not already loaded.
4. Type LO ESDBB.EXE/ST:200 to load the DMC exerciser.
5. Type ST 10000 to start the diagnostic supervisor.
6. Type ST to start the DMC exerciser.
7. Answer questions posed by the program concerning the units to be tested, the TR number, the adaptor BR level, the device BR level, the UBA number, the Unibus device address, and yes for internal loopback. For example:

```
SELECT UNITS: DMC1:
ENTER TR NUMBER [1-16(D)]: 3
ENTER ADAPTOR BR LEVEL [4-7(D)]: 4
ENTER DEVICE BR LEVEL [4-7(D)]: 5
ENTER UBA NUMBER [0-3(D)]: 0
ENTER UNIBUS DEVICE ADDRESS
[00000760000-00000777776 (0)]: 760070
INTERNAL LOOPBACK [Y OR N]: Y
```

8. Console terminal output:

```
>>>HALT
      HALTED AT 000014FCB
>>>LO ESDBB.EXE/ST:200
      LOAD DONE, 00002600 BYTES LOADED
>>>ST 10000
DIAGONSTIC SUPERVISOR.  ZZ-ESSAA-3.05-203 14-DEC-1977 14:10:59.99
DS><ST
PROGRAM:  ESDBB DMC EXERCISER, REV 1, DEPO 0.
***** SIZER NOT YET IMPLEMENTED *****
SELECT UNITS: DMC1:
```

```

FOR DEVICE: DMC1
  ENTER TR NUMBER [1-16(D)]: 3
  ENTER ADAPTER BR LEVEL [4-7(D)]: 4
  ENTER DEVICE BR LEVEL [4-7(D)]: 5
  ENTER UBA NUMBER [0-3(D)]: 0
  ENTER UNIBUS DEVICE ADDRESS [00000760000-00000777776(0)]:
  760070

USE INTERNAL LOOPBACK [(Y), Y OR N]: Y

UNIBUS INTERRUPT VECTORED TO: 000300
END OF RUN, 1 PASSES. 0 ERRORS DETECTED, TIME: 14-DEC-1977
  14:10:59.99

DS>

```

4.9 VAX/VMS BOOTSTRAP FROM AN RP DISK DRIVE

The remaining diagnostic program that must be run for VAX-11/780 system checkout and acceptance can be run with the operating system. If the customer's system includes an RP disk drive, boot the operating system from the RPOX as follows. Otherwise, proceed to Paragraph 4.9.

1. Install the diskette ZZ-ESZAB in the floppy disk drive.
2. Ensure that an RP disk drive (the system device) containing media holding the operating system is on line. Ensure that the five-position key switch on the control panel is in the LOCAL position.
3. If the CPU is running, type

```

Control P
HALT
INITIALIZE
BOOT

```

This sequence puts the CPU into the console wait loop, sets the machine to the initialized state, and begins the VMS bootstrap.

4. If the CPU is already in the console wait loop (halted), type BOOT. This initiates the VMS bootstrap.
5. The VMS operating system identifies itself. Enter the date and time if requested, e.g.:

```

15-FEB-1978 19:15

```

VMS types out initialization information. Type a carriage return.

6. VMS prompts for user name and password. For use of the field service account type FIELD for user name, and SERVICE for password.
7. VMS displays the prompt symbol, \$.

8. Console terminal output:

```
>>>HALT
      HALTED AT 00014FC1
>>>I
      INIT SEQ DONE
>>>BOOT
      CPU HALTED
      INIT SEQ DONE
      LOAD DONE, 00000800 BYTES LOADED
BOOTING FROM DRIVE #1
      VAX/VMS BASE LEVEL 4.XA 9-JAN-78
PLEASE RETURN DATE AND TIME (DD-MMM-YYYY HH:MM) 15-FEB-1978 19:15
Opcom, 15-FEB-1978 19:15:48.72, Logfile initialized, operator=TTA0
      WELCOME TO VAX/VMS BASE LEVEL 4.XA
$SET NOVERIFY
HELP IS NOW AVAILABLE
      PREVIOUS LOGICAL NAME ASSIGNMENT REPLACED
      PREVIOUS LOGICAL NAME ASSIGNMENT REPLACED
      PREVIOUS LOGICAL NAME ASSIGNMENT REPLACED
      PREVIOUS LOGICAL NAME ASSIGNMENT REPLACED
      PREVIOUS LOGICAL NAME ASSIGNMENT REPLACED
NO TTY1 "ADV 11 ENGINEERING SYSTEM NOW UP FOR TIMESHARING"
USER NAME: FIELD
PASSWORD: [SERVICE]
      WELCOME TO VAX/VMS BASE LEVEL 4.XA
$
```

4.10 VAX/VMS BOOTSTRAP FROM AN RK06 DISK DRIVE

Boot the operating system from the RK06 as follows.

1. Install the diskette ZZ-ESZAB in the floppy disk drive.
2. Ensure that an RK06 disk drive (the system device) containing media holding the operating system is on line.
3. Type Control P to return control to the console program.
4. Type HALT to halt the system.
5. Type BOOT or BOOT DM0 to boot VMS.
6. The operating system identifies itself and prompts for date and time.
7. Enter the date and time if requested, e.g.,:

```
15-FEB-1978 19:15
```

VMS types out initialization information. Type a carriage return.

8. VMS prompts for user name and password. For use of the field service account type FIELD for user name, and SERVICE for password.
9. VMS displays the prompt symbol, \$.
10. Console terminal output:

```

^ P
>>>HALT
>>>BOOT DMO

CPU HALTED
INIT SEQ DONE
LOAD DONE,00000800 BY TES LOADED

VAX/VMS BASE LEVEL 4.X9 6-JAN-78

Opcom-10-MAR-1978 09:18:11.29, Logfile initialized, operator=TTA0
      WELCOME TO VAX/VMS BASE LEVEL 4.X9

$SET VERIFY
$SET NOON
$ASSIGN/SYSTEM SYS$INPUT: FOR005:
$ASSIGN/SYSTEM SYS$OUTPUT: FOR006:
$ASSIGN/SYSTEM SYS$INPUT: FOR$ACCEPT:
      PREVIOUS LOGICAL NAME ASSIGNMENT REPLACED
$ASSIGN/SYSTEM SYS$INPUT: FOR$READ:
      PREVIOUS LOGICAL NAME ASSIGNMENT REPLACED
$ASSIGN/SYSTEM SYS$OUTPUT: FOR$PRINT:
      PREVIOUS LOGICAL NAME ASSIGNMENT REPLACED
$ASSIGN/SYSTEM SYS$OUTPUT: FOR$TYPE:
      PREVIOUS LOGICAL NAME ASSIGNMENT REPLACED
$ASSIGN/SYSTEM DMO: LB0:
$ASSIGN/SYSTEM DMO: SY0:
$ASSIGN/SYSTEM$DISK: [1,1] SYS$LIBRARY:
      PREVIOUS LOGICAL NAME ASSIGNMENT REPLACED
$ASSIGN/SYSTEM SYS$DISK: [10,20] SYS$HELP:
$INITIALIZE/FLAG/QUEUE/GENERIC SYS$PRINT
$START/QUEUE SYS$PRINT

$INITIALIZE/QUEUE/FLAG LPA0
$START/QUEUE LPA0
$INITIALIZE/QUEUE/BATCH/JOB: 10 SYS$BATCH
$START/QUEUE SYS$BATCH
$SET UIC [1,2]
$PURGE/KEEP: 2 OPERATOR.LOG
$LOGOUT
USER NAME: FIELD
PASSWORD: [SERVICE]

      WELCOME TO VAX-VMS BASE LEVEL 4.X9

$

```

4.11 DEVICE MNEMONIC IDENTIFICATION

1. Type Control Y to return control to VMS if VMS is not already in control.
2. Type SHOW DEV to list the mnemonic identification of each of the peripheral devices on the system. Note that off-line indicates that the device is not present and not supported.
3. Console terminal output:

```
$ SHOW DEV
List of Device
Device Device      Device      on      10-MAR-1978 09:22:37.30
Name   Status  Characteristics  Err.   Volume  Free   Trans  Mount
                                Count  Label   Blocks Count  Count

DBA0:  on line                                0
DBA1:  on line                                0
DBA2:  on line                                0
DBA3:  on line                                0
DBB0:  off line                               0
DBB1:  off line                               0
DBB2:  off line                               0
DBB3:  off line                               0
DMA0:  on line MNT                          0      UETP    3555    9      1
DMA1:  on line                                0
DMA2:  on line                                0
MTA0:  on line                                0
MTA1:  on line                                0
TTA0:  on line                                0
DXA1:  on line                                0
CRA0:  off line                               0
LPA0:  off line                               0
LPB0:  off line                               0
TTB0:  on line                                0
TTB1:  on line                                0
TTB2:  on line                                0
TTB3:  on line                                0
TTB4:  on line                                0
TTB5:  on line                                0
TTB6:  on line                                0
TTB7:  on line                                0
TTC0:  off line                               0
TTC1:  off line                               0
TTC2:  off line                               0
TTC3:  off line                               0
TTC4:  off line                               0
TTC5:  off line                               0
TTC6:  off line                               0
TTC7:  off line                               0
TTD0:  off line                               0
TTD1:  off line                               0
TTD2:  off line                               0
TTD3:  off line                               0
TTD4:  off line                               0
TTD5:  off line                               0
TTD6:  off line                               0
TTD7:  off line                               0
TTE0:  off line                               0
TTE1:  off line                               0
TTE2:  off line                               0
TTE3:  off line                               0
```

```

TTE4:  off line          0
TTE5:  off line          0
TTE6:  off line          0
TTE7:  off line          0
TTG0:  off line          0
TTG1:  off line          0
TTG2:  off line          0
TTG3:  off line          0
TTG4:  off line          0
TTG5:  off line          0
TTG6:  off line          0
TTG7:  off line          0
TTH0:  off line          0
TTH1:  off line          0
TTH2:  off line          0
TTH3:  off line          0
TTH4:  off line          0
TTH5:  off line          0
TTH6:  off line          0
TTH7:  off line          0
XMA0:  off line          0
$

```

4.12 TRANSFERRING DIAGNOSTIC FILES: FLOPPY → SYSTEM

To load and run user mode diagnostics from the operating system, the operator must transfer the diagnostic files from floppy disk to the Field Service VMS pack on a system device.

Proceed as follows:

1. Insert diskette ZZ-ESZEB into the floppy disk drive, and type Control Y to return control to VMS.
2. Type ALL DXA1: to allocate the floppy disk drive.
3. Type MOUNT/FOR DX1: to mount the disk.
4. In response to the \$ prompt type in MCR FLX to invoke the FILEX program.
5. Type /CO/BL:512./RS=DX1:ESSAA.EXE/RT/IM to transfer the diagnostic supervisor to the system device.
6. Insert the diskette containing the file or files to be transferred.
7. Transfer the user mode diagnostic programs from floppy to the system device one at a time by typing /RS=DX1:<CODE>.EXE/RT/IM where <CODE> is the mnemonic of the diagnostic program. For example, ESMAA is the mnemonic for the tape reliability program.

Diskette ZZ-ESZ1B contains:

```

ESRAB  RK06/RPOX/RM03 Formatter
ESMAA  Tape Reliability
ESRAA  RK06/RPOX/RM03 Reliability
ESTAA  Local Terminal Diagnostic
ESTBA  Multiterminal Diagnostic
ESAAA  Line Printer Diagnostic

```

Diskette ZZ-ESZAA contains:

```

ESXBA  Bus Interaction Program
ESABA  CR11 Card Reader
        Diagnostic

```

8. Type Control Y to return from FILEX to VMS.
9. Type DISM DX1: to dismount the diskette.
10. Type DEALL DXA1: to deallocate the floppy disk drive.
11. Console terminal output:

```

$    ALL DXA1:
      DXA1 ALLOCATED
$    MOUNT/FOR DX1:

$    MCR  FLX

FLX>  /CO/BL:512./RS=DX1:ESSAA.EXE/RT/IM
FLX>  /RS=DX1:ESMAA.EXE/RT/IM
FLX>  ^Y

$    DISM DX1:
$    DEALL DXA1:
$

```

4.13 RELOADING THE DIAGNOSTIC SUPERVISOR

1. The diagnostic supervisor must be reloaded into main memory from the system device after VMS has been booted.
2. When the operating system prompts with \$, type RUN ESSAA to load and start the diagnostic supervisor.
3. The diagnostic supervisor starts, signaling the operator with the prompt, DS>.

4.14 TAPE RELIABILITY (ESMAA)

Run one pass.

Run Time: 15 min/drive

1. Mount a write enabled tape on each of the drives to be tested and ensure that each drive is on line.
2. Type Control Y to return to VMS.
3. Type RUN ESSAA to load and run the diagnostic supervisor.
4. Type RUN ESMAA to load and run the reliability program.
5. Supply the requested information.

6. Console terminal output:

```
$ RUN ESSAA
DIAGNOSTIC SUPERVISOR. ZZ-ESSAA-3.06-230 22-FEB-1978 19:51:40.35
DS> RUN ESMAA
PROGRAM LOADED: ESMAA TM03/TE16,TU77 DATA RELIABILITY DIAGNOSTIC

PROGRAM: ESMAA TM03/TE16,TU77 DATA RELIABILITY DIAGNOSTIC, REV 3,
DEPO 0.

***** SIZER NOT YET IMPLEMENTED *****

SELECT UNITS: MTA0:

SUMMARY OF TOTAL ERRORS FOR _MTA0
WRITE SOFT ERRORS = 125
WRITE HARD ERRORS = 0
WRITE CHECK FORWARD SOFT ERRORS = 125
WRITE CHECK FORWARD HARD ERRORS = 0
WRITE CHECK REVERSE SOFT ERRORS = 128
WRITE CHECK REVERSE HARD ERRORS = 0
READ FORWARD SOFT ERRORS = 125
READ FORWARD HARD ERRORS = 0
READ REVERSE SOFT ERRORS = 125
READ REVERSE HARD ERRORS = 0
TOTAL NUMBER OF BYTES TRANSFERRED = 6591665
END OF RUN, 1 PASSES. 0 ERRORS DETECTED, TIME: 22-FEB-1978
20:02:13.14

DS>
```

4.15 RP/RK/RM DISK FORMATTER (ESRAB)

Run one pass.

Run Time: 2 min/RK06
4 min/RK07
5 min/RP04/05
8 min/RK06

If the operator has a formatted scratch disk pack on hand, there is no need to run this program.

1. Type Control Y to return control to VMS.
2. Type RUN ESSAA to load and run the diagnostic supervisor.
3. Type RUN ESRAB to load and run the disk formatter program.
4. Select the unit to be tested, e.g., DB2:.

5. Console terminal output:

```
$ RUN ESSAA
DIAGNOSTIC SUPERVISOR. ZZ-ESSAA-3.05-203 15-FEB-1978 19:43:44.01

DS> RUN ESRAB

PROGRAM LOADED: VAX DISK FORMATTER MAINDEC CODE: ZZ-ESRAB-1.0

PROGRAM: VAX DISK FORMATTER MAINDEC CODE: ZZ-ESRAB-1.0, REV 0,
DEPO 0.

***** SIZER NOT YET IMPLEMENTED *****

SELECT UNITS: DB2:
VOLUME ON DB2 PASSED PROTECTION CHECK; PACK NAME IS 'SCRATCH'.
FORMAT OPERATION ON DB2 INITIATED AT 15-FEB-1978 19:44:00.36
HEADER VERIFICATON COMPLETE AT 6-OCT-1859 02:19:29.43
FORMAT OPERATION ON DB2 COMPLETE AT 15-FEB-1978 19:53:04.07
END OF RUN, 1 PASSES. 0 ERRORS DETECTED, TIME: 15-FEB-1978
19:53:06.32

DS>
```

4.16 RP/RK/RM DISK RELIABILITY PROGRAM (ESRAA)

Run one pass.

Run Time: Multidrive section - indefinite.

1. Type Control Y to return control to VMS.
2. Type RUN ESSAA to load and run the diagnostic supervisor.
3. Mount a scratch pack on the disk drive to be tested.
4. Type RUN ESRAA/SEC:MULTI to load and run the RPOX/RK06 reliability program seek and multidrive sections.
5. Supply the information requested, e.g.,
SELECT UNITS: DB2:
TR NUMBER: 8
ADAPTER BR LEVEL: 5
6. If the program runs without error indications for 1/2 hour, type Control C to exit from the program.
7. Repeat the multidrive section of the program for each disk drive.
8. Console terminal output:

```
DS> RUN ESRAA/SEC:MULTI
PROGRAM LOADED: VAX DISK RELIABILITY TESTS MAINDEC CODE:
ZZ-ESRAA-1.0

PROGRAM: VAX DISK RELIABILITY TESTS MAINDEC CODE: ZZ-ESRAA-1.0,
REV 0, DEPO 0.
```

```
***** SIZER NOT YET IMPLEMENTED *****
```

```
SELECT UNITS: DB2:
```

```
FOR DEVICE: DB2
```

```
ENTER TR NUMBER [1-16(D)]: 8
```

```
ENTER ADAPTER BR LEVEL [4-7(D)]: 5
```

```
DB2 IS A RP05
```

```
VOLUME ON DB2 PASSED PROTECTION CHECK; PACK NAME IS 'SCRATCH'.
```

```
MULTI DRIVE TESTS INITIATED
```

```
END OF RUN, 1 PASSES. 0 ERRORS DETECTED,
```

```
TIME: 20-FEB-1978 11:50:00.00
```

```
DS>
```

4.17 MULTITERMINAL EXERCISER (ESTBA)

Run one pass.

Run Time: 3-30 min

1. Type Control Y to return control to VMS.
2. Set standard baud rates for each terminal to be tested with commands to VMS as follows:

```
SET TERM <term-name>: /<term-type> for example,
```

```
SET TERM TTB5: /LA36
```

```
SET TERM TTA3: /VT52
```

These commands will set system baud rates of 300 for the LA36 and 2400 for the CRT terminals. Corresponding baud rates should be selected by setting the appropriate switches on each terminal.

If you wish to set some other baud rate, use the following command:

```
SET TERM <term-name>: /<term-type>/SPEED=<baud-rate> for example,
```

```
SET TERM TTB3: /VT55/SPEED=9600
```

3. Type RUN ESSAA to load and run the diagnostic supervisor.
4. Type RUN ESTBA to load and start the multiterminal exerciser program.
5. Supply the requested information.
6. Console terminal output:

```
$ RUN ESSAA
```

```
DIAGNOSTIC SUPERVISOR. ZZ-ESSAA-3.06-230 22-FEB-1978 20:30:37.50
```

```
DS> RUN ESTBA
```

```
PROGRAM LOADED: ESTBA MULTI TERMINAL DIAGNOSTIC
```

```
PROGRAM: ESTBA MULTI TERMINAL DIAGNOSTIC, REV 3, DEPO 0.
```

```
***** SIZER NOT YET IMPLEMENTED *****
```

```
SELECT UNITS: TTB0:  
TERMINAL CHARACTERISTICS  
SCOPE ,NOWRAP ,MECHTAB ,LOWERCASE ,NOTTSYNC ,HOSTSYNC  
  
END OF RUN, 1 PASSES. 0 ERRORS DETECTED, TIME: 22-FEB-1978  
20:35:23.41  
  
DS>
```

4.18 LOCAL TERMINAL DIAGNOSTIC

Run one pass.

Run Time: 3-30 min

1. Type Control Y to return control to VMS.
2. Type RUN ESSAA to load and run the diagnostic supervisor.
3. Type RUN ESTAA/SEC:MANUAL/TEST: 33 to run the any pattern echo test.
4. Select the terminals to be tested.
5. Execute the any pattern echo test on each terminal to be tested, as follows.

UP TO 132 KEYS MAY BE TYPED EXCEPT FOR THE DELETE KEY, WHICH IS USED AS AN INPUT TERMINATOR. THE BUFFER WILL THEN BE OUTPUT EXACTLY AS IS, AND ANY CODES WHICH GENERATE CONTROL FUNCTIONS WILL CAUSE THOSE FUNCTIONS TO OCCUR. THE DIAGNOSTIC WILL ECHO THIS BUFFER 25 TIMES FOLLOWED BY A SLIGHT DELAY. IF THE OPERATOR WISHES TO CHANGE THE PATTERN, HE/SHE MAY STRIKE ANY KEY. WHEN THE DIAGNOSTIC FINISHES ITS 25 ECHOS, IT WILL THEN ASK THE OPERATOR WHAT HE WISHES TO DO. TO EXIT FROM THE TEST TYPE THE DELETE KEY IN RESPONSE TO THE MESSAGE ENTER PROMPT, OR TYPE CONTROL Y.

Console terminal output:

```
$ RUN ESSAA  
DIAGNOSTIC SUPERVISOR. ZZ-ESSAA-3.05-203 2-MAR-1978 11:54:16.33  
  
DS> RUN ESTAA/SEC:MANUAL/TEST:33  
PROGRAM LOADED: ESTAA LOCAL TERMINAL DIAGNOSTIC  
  
PROGRAM: ESTAA LOCAL TERMINAL DIAGNOSTIC, REV 1, DEPO 0.  
  
***** SIZER NOT YET IMPLEMENTED *****  
  
SELECT UNITS: TTC0:  
TERMINAL CHARACTERISTICS  
NOWRAP,LOWERCASE  
  
ENTER PATTERN END WITH DEL KEY  
NOW IS THE TIME FOR MEN TO COME TO THE AID OF THEIR COUNTRY.  
NOW IS THE TIME FOR MEN TO COME TO THE AID OF THEIR COUNTRY.  
NOW IS THE TIME FOR MEN TO COME TO THE AID OF THEIR COUNTRY.
```

***** SIZER NOT YET IMPLEMENTED *****

SELECT UNITS: TTC0:
TERMINAL CHARACTERISTICS
NOWRAP, LOWERCASE

TYPE KEY FOLLOWED BY DEL

D
104 D
015 CR
A064 4
E 101 A
R105 E
1122 R
2061 1
3062 2
4063 3
5064 4
5065 5
6065 5
7066 6
8067 7
9070 8
071 9
031 EM
031
^Y
\$

4.19 LINE PRINTER DIAGNOSTIC (ESAAA)

Run one pass.

Run Time: 3-15 min/printer

1. Type Control Y to return control to VMS.
2. Type RUN ESSAA to load and run the diagnostic supervisor.
3. Type RUN ESAAA to load and run the line printer diagnostic.
4. Select the unit or units to be tested, e.g., LPA0.
5. Console terminal output:

```
$ RUN ESSAA
DIAGNOSTIC SUPERVISOR. ZZ-ESSAA-3.05-203 15-FEB-1978 20:23:39.77

DS> RUN ESAAA
PROGRAM LOADED: ESAAA LINE PRINTER DIAGNOSTIC

PROGRAM: ESAAA LINE PRINTER DIAGNOSTIC, REV 1, DEPO 0.
```

```
***** SIZER NOT YET IMPLEMENTED *****
```

```
SELECT UNITS: LP:  
PRINTER CHARACTERISTICS  
MECHFORM
```

```
END OF RUN, 1 PASSES. 0 ERRORS DETECTED, TIME: 15-FEB-1978  
20:26:46.85
```

```
DS>
```

4.20 BUS INTERACTION (ESXBA)

Run one pass.

Run Time: 15 min, typical.

1. Ensure that the diagnostic supervisor is running in the user mode.
2. Type RUN ESXBA to load and run the BUSINT program.
3. Select the units to be tested and supply the TR number for each, e.g., DBA2:, DBA3:, MTA0:, MTA1:, DMA0:, DMA3:.
4. Console terminal output:

```
$  
$RUN DS  
DIAGNOSTIC SUPERVISOR. ZZ-ESSAA-X3.06-225 15-JAN-1978 14:43:20.99  
  
DS> LOAD ESXBA  
PROGRAM LOADED: ESXBA-BUSINT - VAX-11/780 BUS INTERACTION PROGRAM  
  
DS> START  
  
***** SIZER NOT YET IMPLEMENTED *****  
  
SELECT UNITS: DBA2:, DBA3:, MTA0:, MTA1:, DMA0:, DMA3:  
ENTER TR NUMBER: [(0), 1-15 (D)]: 8  
ENTER TR NUMBER: [(0), 1-15 (D)]: 8  
ENTER TR NUMBER: [(0), 1-15 (D)]: 8  
ENTER TR NUMBER: [(0), 1-15 (D)]: 8  
ENTER TR NUMBER: [(0), 1-15 (D)]: 3  
ENTER TR NUMBER: [(0), 1-15 (D)]: 3  
MAX WORKSET LIMIT OBTAINED: 500  
PROCESS SWAPPING ENABLED.  
MAXIMUM BUFFER SPACE OBTAINED: 2000 PAGES. STARTING ADDRESS:  
00019E00 (X), END ADDRESS 001130FF (X).  
  
MBAINTEST SECTION  
  
TESTING MBA 0 USING...  
  _DBA2  
  _DBA3  
  _MTA0  
  _MTA1
```

UBAINT TEST SECTION

TESTING UBA 0 USING...

 DMA0
 DMA1

SBIINT TEST SECTION

TESTING SBI USING...

WITH MBA DEVICES:

 DBA2
 DBA3
 MTA0
 MTA1

WITH UBA DEVICES:

 DMA0
 DMA1

PASSES COMPLETED: 1

SYSTEM TOTALS	THIS PASS	THIS RUN
SYSTEM ERRORS	0	0
DEVICE ERRORS	0	0
HARD ERRORS	0	0
DATA ERRORS	0	0
BYTES INPUT	16368000	16368000
BYTES OUTPUT	16380000	16368000
TOTALS BY MBA:	THIS PASS	THIS RUN
MBA0		
DEVICE ERRORS	0	0
HARD ERRORS	0	0
SOFT ERRORS	0	0
DATA ERRORS	0	0
BYTES INPUT	9820800	9820800
BYTES OUTPUT	9820800	9820800
TOTALS BY UBA:	THIS PASS	THIS RUN
UBA0		
DEVICE ERRORS	0	0
HARD ERRORS	0	0
SOFT ERRORS	0	0
DATA ERRORS	0	0
BYTES INPUT	6547200	6547200
BYTES OUTPUT	6547200	6547200
TOTALS BY DEVICE:	THIS PASS	THIS RUN
DEVICE: DBA2		
DEVICE ERRORS	0	0
HARD ERRORS	0	0
SOFT ERRORS	0	0
DATA ERRORS	0	0
BYTES INPUT	3273600	3273600
BYTES OUTPUT	3273600	3273600

DEVICE: DBA3		
DEVICE ERRORS	0	0
HARD ERRORS	0	0
SOFT ERRORS	0	0
DATA ERRORS	0	0
BYTES INPUT	3273600	3273600
BYTES OUTPUT	3273600	3273600

DEVICE: DBA3		
DEVICE ERRORS	0	0
HARD ERRORS	0	0
SOFT ERRORS	0	0
DATA ERRORS	0	0
BYTES INPUT	3273600	3273600
BYTES OUTPUT	3273600	3273600

DEVICE: MTA0		
DEVICE ERRORS	0	0
HARD ERRORS	0	0
SOFT ERRORS	0	0
DATA ERRORS	0	0
BYTES INPUT	3273600	3273600
BYTES OUTPUT	3273600	3273600

DEVICE: MTA1		
DEVICE ERRORS	0	0
HARD ERRORS	0	0
SOFT ERRORS	0	0
DATA ERRORS	0	0
BYTES INPUT	3273600	3273600
BYTES OUTPUT	3273600	3273600

DEVICE: DMA0		
DEVICE ERRORS	0	0
HARD ERRORS	0	0
SOFT ERRORS	0	0
DATA ERRORS	0	0
BYTES INPUT	3273600	3273600
BYTES OUTPUT	3273600	3273600

DEVICE: DMA1		
DEVICE ERRORS	0	0
HARD ERRORS	0	0
SOFT ERRORS	0	0
DATA ERRORS	0	0
BYTES INPUT	3273600	3273600
BYTES OUTPUT	3273600	3273600

END OF RUN, 1 PASSES, 0 ERRORS DETECTED, TIME: 15-JAN-1978
14:55:20:99

DS>

4.21 USER ENVIRONMENT TEST PACKAGE (UETP)

Run one pass.

Run Time: system specific.

The user environment test package is a collection of tests included on the VAX/VMS system disk. When the UETP runs correctly, it demonstrates that the hardware and software components of the VAX/VMS system are in working order. Run one pass of the UETP as follows.

1. Log out from the field service account:

```
$ LOGOUT
```

The system responds:

```
VAX/VMS LOGOUT at 12:30:10 17-JUL-1978
```

2. Log in to the SYSTEST account:

```
<CR>
```

```
USERNAME: SYSTEST
```

```
PASSWORD: UETP
```

3. Prepare the devices for testing. For each disk drive to be tested (not the system load device), perform the following steps:

Physically mount a scratch disk.

Set the drive to RUN.

Issue the following commands:

```
$ INIT/DATA CHECK DMA0: TEST 1  
$ MOUNT/SYSTEM DMA0: TEST 1  
$ CREATE/DIRECTORY DMA0: SYSTEST  
$ CREATE/DIRECTORY DMA0: 7
```

NOTE

When repeating this set of commands for each disk drive on the system, be sure to specify the device name (e.g., DMA0).

For each magnetic tape drive perform the following steps:

Physically mount a write enabled scratch tape at least 183 m (600 ft) long.

Press the ONLINE switch.

For each hard copy terminal and line printer, check the paper supply (2 pages for one pass of the UETP).

Press the ONLINE switch. Check the baud rates and terminal characteristics (these should still be set according to specifications given in Paragraph 4.17).

- Run the entire UETP by entering the UETP command procedure and responding to the three prompts, as shown below.

```

$ @ UETP/OUTPUT TEST=DATA
VAX/VMS UETP STARTED dd-mmm-yy hh:mm
ENTER NUMBER OF LOAD TEST USERS [D]: n*
ENTER NUMBER OF COMPLETE UETP TEST RUNS [D]: 1
ENTER SCRATCH MAGTAPE (E.G. MT0:) OR A <CR> device-name
<CR>

```

Table 4-1 Guideline for Selecting Number of Load Test Users

Size of Memory	Number of Load test users
256K	10
384K	15
512K	20
640K	25
768K	30
896K	35
1 megabyte	40
<hr/>	
256K	6
384K	9
512K	12
640K	15
768K	18
896K	21
1 megabyte	25

- Check the operator terminal output for errors. Indication of errors in this output (short file) can be followed up with an examination of the output file specified in the UETP command line (TEST DATA). In addition, UETP LOG, is a large log file containing a concatenation of individual log files from the following tests:

- The I/O device tests
- The native mode utility tests
- The system load test
- The compatibility mode tests

***Note:** Table 4-1 specifies responses to the load test users question, according to memory size.

6. If it becomes necessary to interrupt or terminate the UETP run, use the following commands, as appropriate.

First, type

^Y ; Control Y interrupts the
; current UETP test and
; temporarily returns control
; to the command language
; interpreter.

then

STOP ; Terminate execution of
; the UETP.

or

CONTINUE ; Continue the test from
; the point of interruption.

APPENDIX A HARDWARE DIAGNOSTIC ADDITIONS

A.1 SBI EXPANDER CABINET INSTALLATION

1. If the system to be installed includes an SBI expander cabinet, it should be placed between the system cabinet and the Unibus expander cabinet. The cabinets should not be bolted together until after the intercabinet cabling has been completed.
2. Three cables are tie wrapped to the bottom of the SBI expander cabinet on the side adjacent to the system cabinet. These should be attached to the appropriate receptacles on the I/O panel connector on the right side of the system cabinet. The six pin connector (ACLO-DCLO adapter cable) must be plugged into J7. Plug the three pin connector (DIGITAL power control bus cable) into J8. Plug the four pin connector (-5 V, +5 V, ground cable to SFT) into J9 (Figure 3-11).
3. Connect the three pin connector (DIGITAL power control bus cable), which is tie wrapped to the bottom of the Unibus expander cabinet, to J8 of the I/O panel on the right side of the SBI expander cabinet (Figure 3-11).
4. Route the three Unibus cables from the first BA11-K box in the Unibus expander cabinet along the bottom of the SBI expander cabinet. Connect the Unibus cables to the appropriate receptacles on the I/O panel on the right side of the system cabinet (P2 to J3, P1 to J2, P3 to J1, as shown in Figure 3-11).
5. Route the Massbus cables from the TM03 formatter through the Unibus expander cabinet and connect them to the I/O panel on the SBI expander cabinet or the system cabinet, depending on which RH780 (MBA) the formatter is to be connected to. Connect the cables to the J4, J5, and J6 receptacles on the selected panel, as shown in Figures 3-11 and 3-13.
6. If RP05, RP06, or RM03 disk drives are present, connect the Massbus cable to J3 on the I/O panel in the rear of the SBI expander cabinet or the system cabinet, depending on which RH780 is to service it.
7. Connect the six SBI cables between the rightmost SBI backplane in the system cabinet and the leftmost backplane in the SBI expander cabinet.
8. Bolt the cabinets together.
9. Connect ground straps between cabinets.
10. Continue with Paragraph 3.6.

A.2 TU45 TAPE DRIVE

If a TU45 tape drive is present, connect three Massbus cables to the expander I/O panel on the VAX-11/780 system cabinet. Cables MB“A”, MB“B”, and MB“C” plug into connectors J6, J5, and J4 on the panel, respectively, with the smooth side to the front and the striped edge down. Connect the other ends of those three Massbus cables to the IN jacks on the M5903 cards on the TM03 formatter, as shown in Figure A-1. If two or more TM03 formatters are included in the system, daisy chain the Massbus cables according to Figure A-2. Note that the last TM03 on the Massbus must be terminated

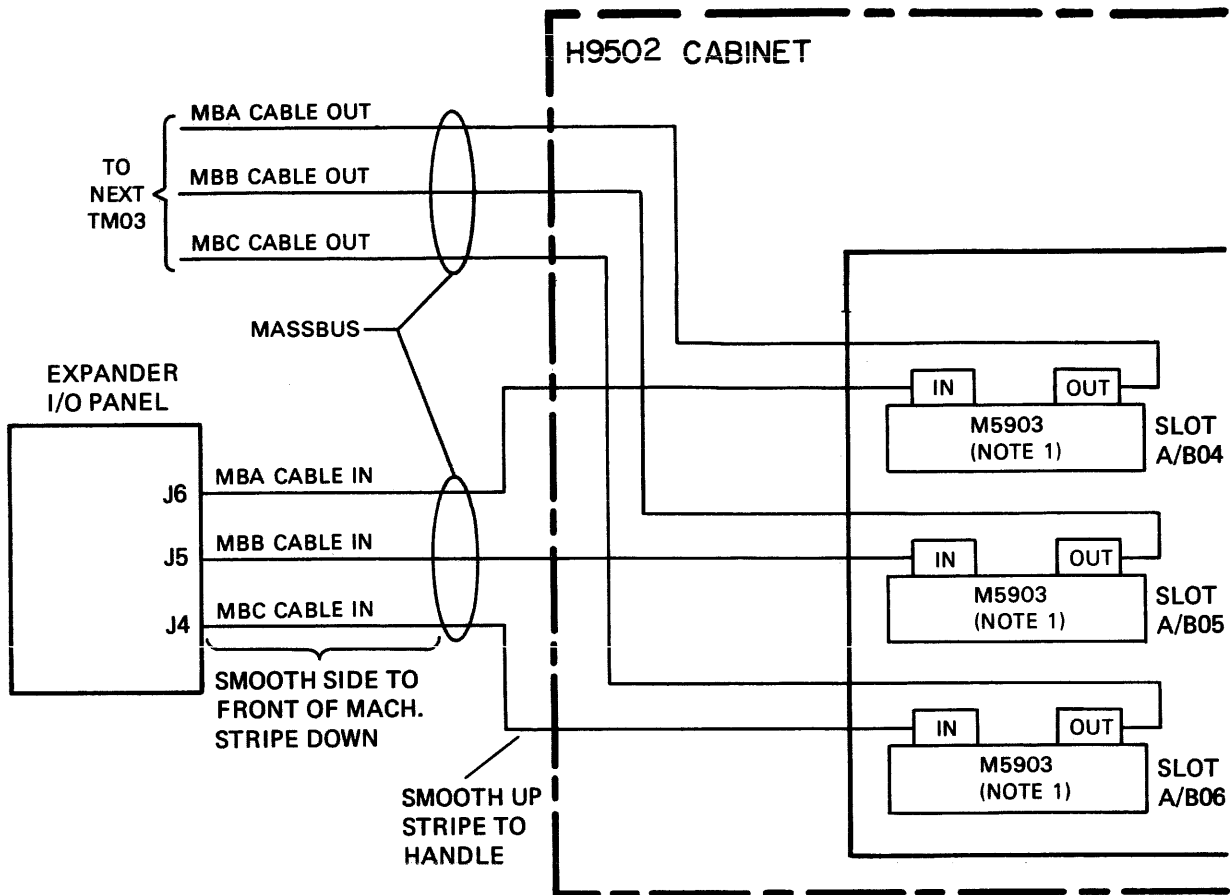

NOTES:

1. IF ONLY ONE TM03 IS USED IN SYSTEM, AN H870 TERMINATOR IS INSERTED INTO EACH OUT JACK, OR M5903-YA MODULES ARE USED WHICH PROVIDE MASSBUS TERMINATION.

TK-0728

Figure A-1 TM03 Cabling for TU45

properly. An H870 terminator must be placed in each of the three OUT jacks. Make sure that jumper W1 is out and jumper W2 is in on the H870 terminator connected to the M5903 module in slot A/B06 (MB“C”).

Daisy chain the DIGITAL power control bus to each 861 power controller.

Connect the three BC06R slave bus cables from the TM03 to J7, J9, and J11 on the MTA board as shown in Figure A-2. Insert the cables so that the smooth side is up and the striped edge is on the left, as shown in Figures A-2 and A-3.

NOTE

BC08R cables connect to the TU45 with 5412192 adapters. The adapters have pin A up at J102 and pin V up at J101 and J103. The ribbed side of the cable faces the rear of the cabinet at J101, J102, and J103.

Connect three BC08R ribbon cables from J1, J2, and J3 on the MTA board to the TU45 transport in the same cabinet, as shown in Figure A-4.

TM03 TO FIRST TU45

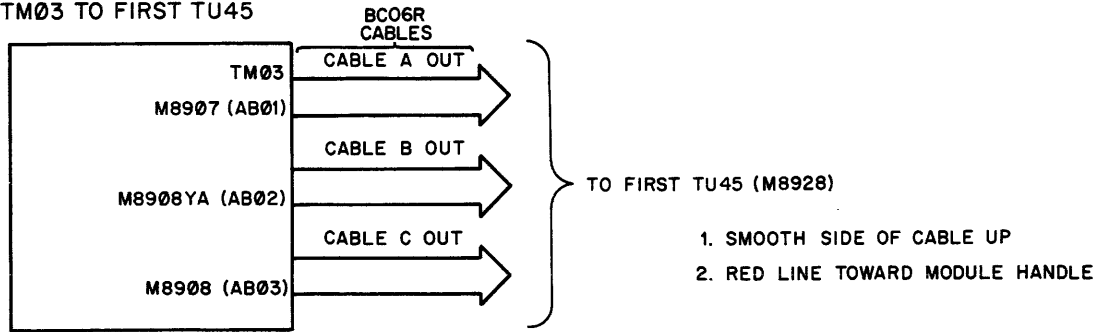

MID-BUS TU45
(MULTI TRANSPORT SYSTEM)

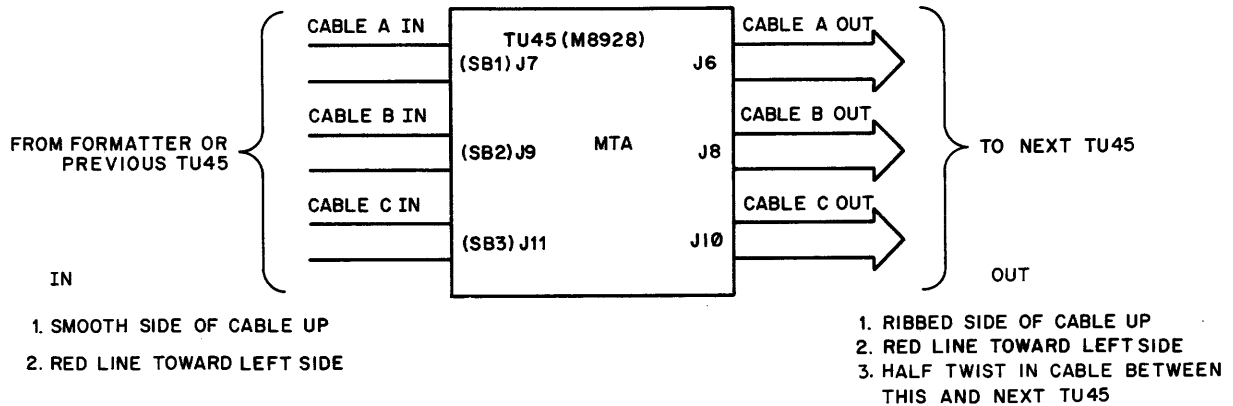

END-OF-BUS TU45

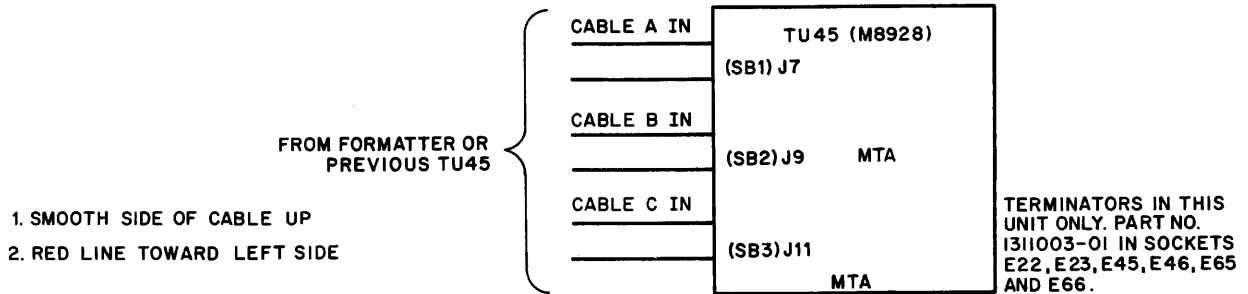

TK-0730

Figure A-2 TM03/TU45 Slave Bus Cabling

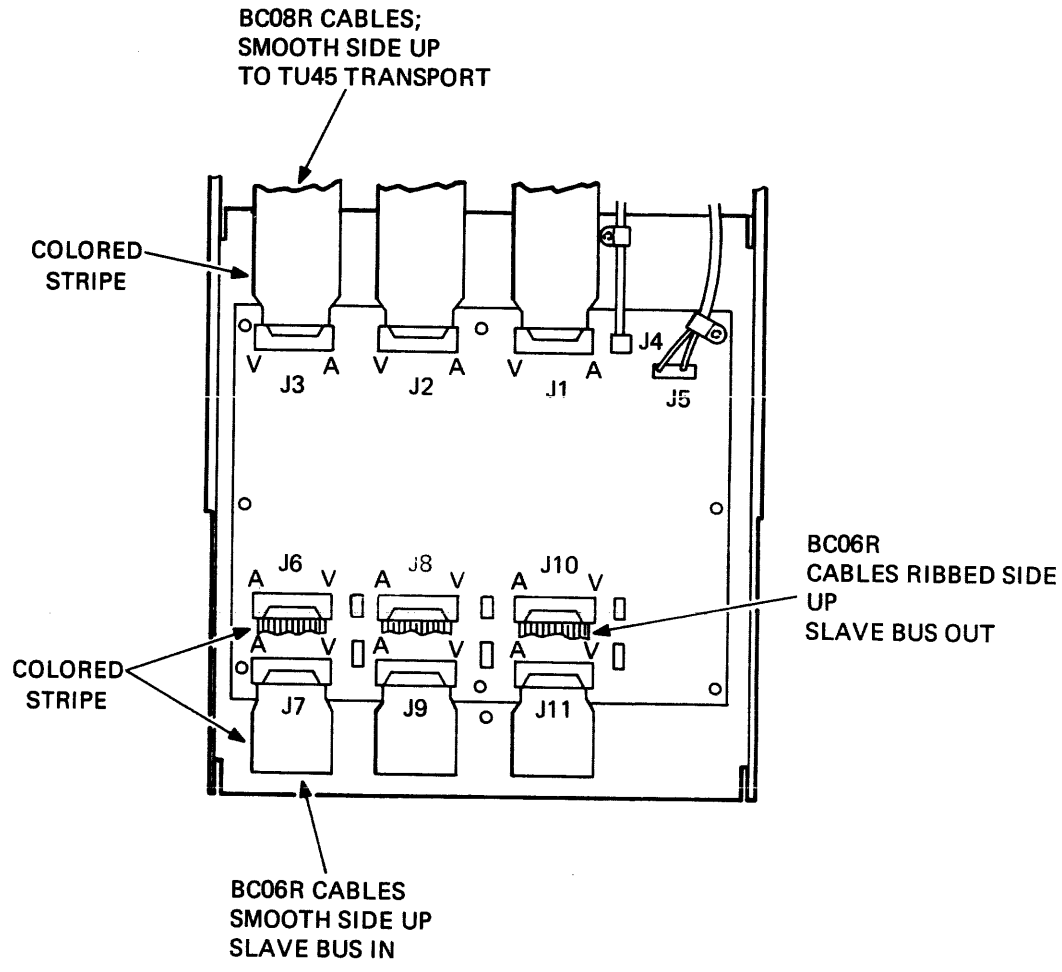

TK-0729

Figure A-3 Cable Orientation on M8928 MTA Module

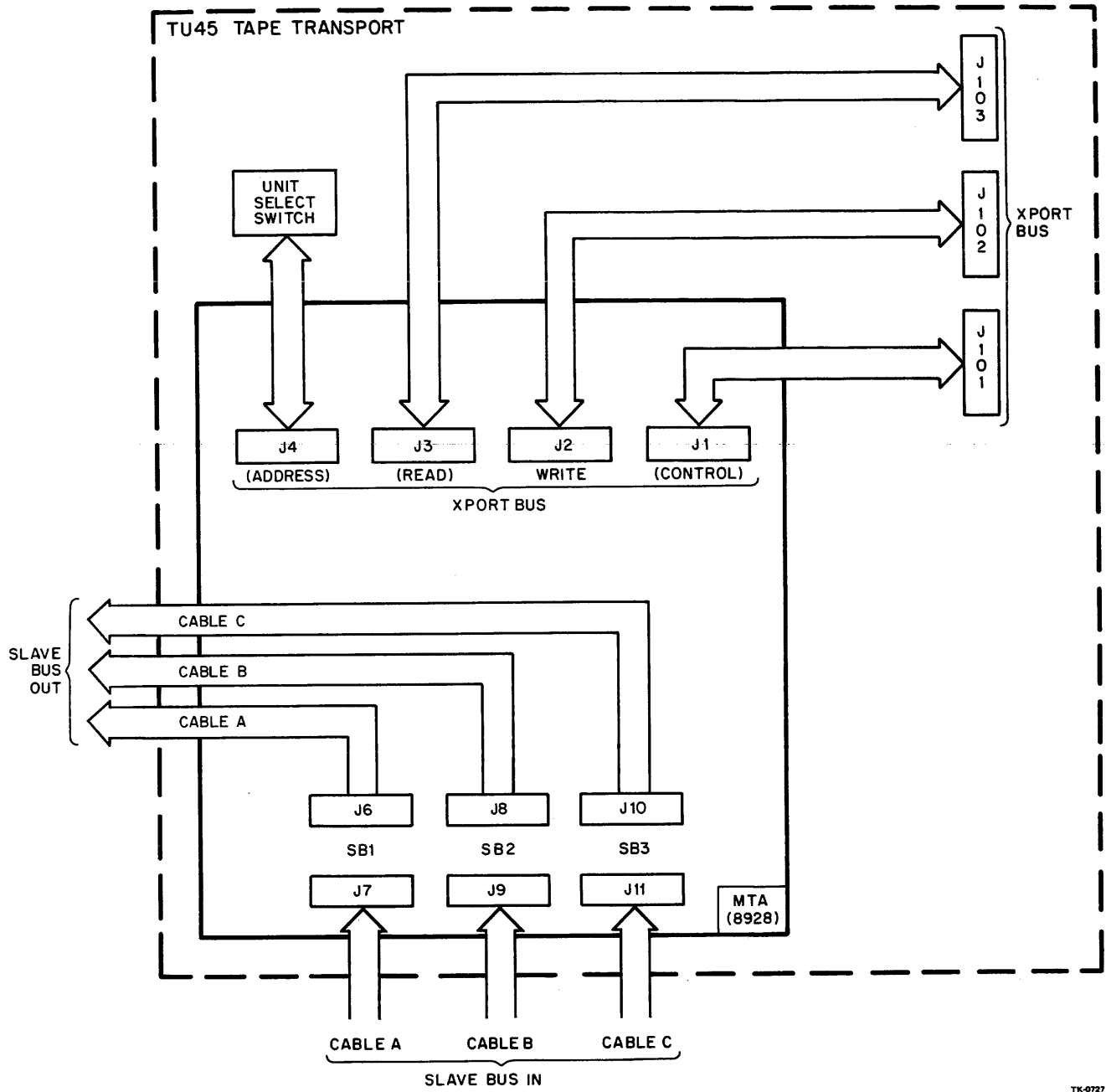

TK-0727

Figure A-4 MTA/TU45 Slave Bus Cabling

If two or more TU45 transports are used, daisy chain the slave bus cables between MTA boards by connecting three BC06R cables from J6, J8, and J10 (slave bus out) on the MTA board for the first transport to J7, J9, and J11 on the MTA board for the next transport. Make sure that the last MTA board in the series is configured properly to terminate the slave bus with DIP resistors (Figure A-2). Figure A-5 shows an overview of the TU45 cabling.

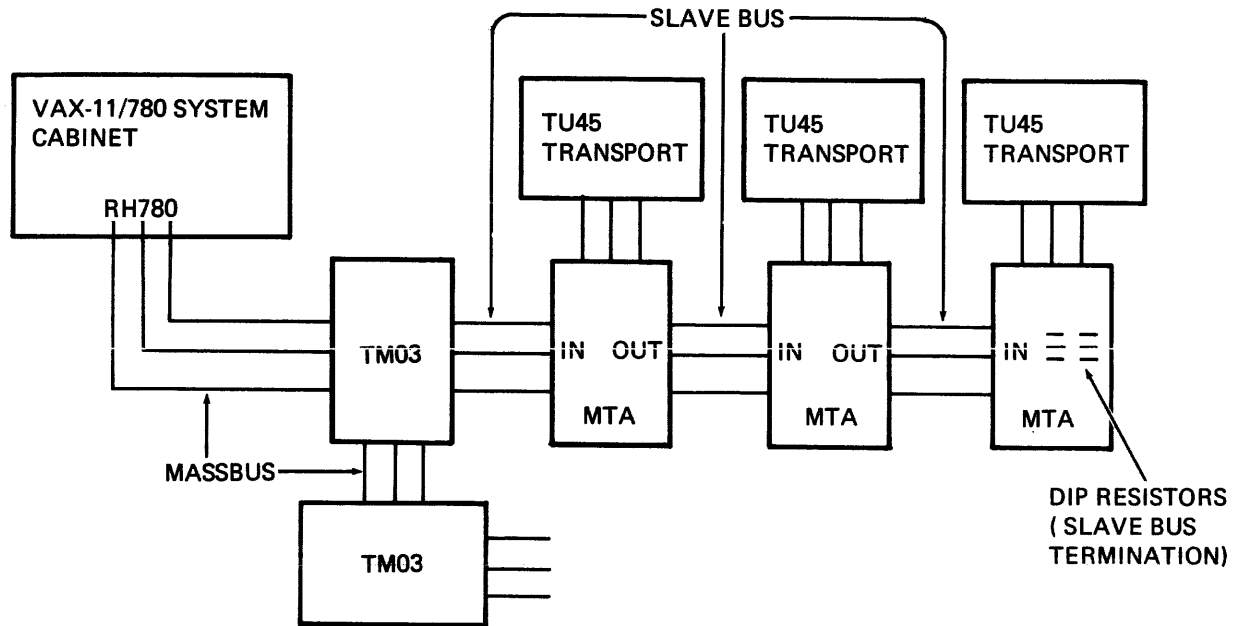

Figure A-5 TU45 Cabling Overview

A.3 DR11-B DIAGNOSTIC (ESDRA)

Run one pass.

1. Insert the test board (M968) in slot 4, connectors C and D of the DR11-B backplane, and then power up the system.
2. Insert diskette ZZ-ESZ3A.
3. Type Control P to return control to the console program and HALT to halt the VAX-11/780 CPU.
4. Type @ESDRA to load the diagnostic supervisor and the DR11-B diagnostic and to start the supervisor.
5. Type ST/SEC:DRB to start the DR11-B diagnostic.
6. Answer the questions posed by the program concerning the units to be tested.

A.4 CR11 CARD READER DIAGNOSTIC

Run one pass.

1. Type Control Y to return control to VMS.
2. Type RUN ESSAA to load and run the diagnostic supervisor.
3. Type RUN ESABA to load and start the CR11 card reader diagnostic.
4. Supply the requested information.
5. Two card decks specifically coded for the program must be used when testing the card reader. Each of the four tests in the program begins by prompting the operator to load either the binary deck or the alphanumeric deck into the hopper.
6. Place the appropriate deck in the hopper. Make sure that the mode switch on the back of the card reader is in the REMOTE position.
7. Press the reset switch to initiate each test after loading the card deck.

Console terminal output:

```
Run ESSAA
DIAGNOSTIC SUPERVISOR. ZZ-ESSAA-X4.03-435 27-JUL-1978
19:57:01.42
DS> RUN ESABA
^^ PROGRAM: ESABA CR11 CARD READER DIAGNOSTIC, REV 1.0, 4 TESTS.
SELECT UNITS: CR:
PUT BINARY DECK INTO HOPPER TO TEST CRB1 (IOS$M_BINARY)
PUT BINARY DECK INTO HOPPER TO TEST CRB2 (IOS$M_PACKED)
PUT ALPHA DECK INTO HOPPER TO TEST CRB1 (IOS$M_BINARY)
PUT ALPHA DECK INTO HOPPER TO TEST CRB2 (IOS$M_PACKED)
^^ END OF RUN. 0 ERRORS DETECTED. PASS COUNT: 1. TIME: 27-JUL-1978
19:59:28
DS>
```

Your comments and suggestions will help us in our continuous effort to improve the quality and usefulness of our publications.

What is your general reaction to this manual? In your judgment is it complete, accurate, well organized, well written, etc.? Is it easy to use? _____

What features are most useful? _____

What faults or errors have you found in the manual? _____

Does this manual satisfy the need you think it was intended to satisfy? _____

Does it satisfy *your* needs? _____ Why? _____

Please send me the current copy of the *Technical Documentation Catalog*, which contains information on the remainder of DIGITAL's technical documentation.

Name _____ Street _____
Title _____ City _____
Company _____ State/Country _____
Department _____ Zip _____

Additional copies of this document are available from:

Digital Equipment Corporation
444 Whitney Street
Northboro, Ma 01532
Attention: Communications Services (NR2/M15)
Customer Services Section

Order No. EK-SI780-IN-001

Fold Here -----

Do Not Tear - Fold Here and Staple -----

**FIRST CLASS
PERMIT NO. 33
MAYNARD, MASS.**

**BUSINESS REPLY MAIL
NO POSTAGE STAMP NECESSARY IF MAILED IN THE UNITED STATES**

Postage will be paid by:

**Digital Equipment Corporation
Technical Documentation Department
Maynard, Massachusetts 01754**

