

EK-RX012-PS-002

RX01/RX02

Pocket Service Guide

1st Edition, November 1980
2nd Edition, September 1981

Copyright © 1981
by Digital Equipment Corporation.
All Rights Reserved.

The reproduction of this material, in part or whole, is strictly prohibited. For copy information, contact the Educational Services Department, Digital Equipment Corporation, Maynard, Massachusetts 01754.

The information in this document is subject to change without notice. Digital Equipment Corporation assumes no responsibility for any errors that may appear in this document.

Printed in U.S.A.

The following are trademarks of Digital Equipment Corporation, Maynard, Massachusetts.

DEC	DECnet	OMNIBUS
DECUS	DECsystem-10	OS/8
DIGITAL	DECSYSTEM-20	PDT
Digital Logo	DECwriter	RSTS
PDP	DIBOL	RSX
UNIBUS	EduSystem	VMS
VAX	IAS	VT
	MASSBUS	

CONTENTS

1 TROUBLESHOOTING

1.1	General	1
1.2	Troubleshooting Charts	2
1.3	Power Supply Voltages	8
1.4	RX8/RX28 Subsystem	9
1.4.1	Bootstrap	13
1.4.2	Registers	13
1.4.3	Interface (M8357)	15
1.5	RX11/RXV11 Subsystem	15
1.5.1	Bootstrap	16
1.5.2	Registers	16
1.5.3	Interfaces (M7846 and M7946)	18
1.6	RX211/RXV21 Subsystem	18
1.6.1	Bootstrap	20
1.6.2	Registers	20
1.6.3	Interfaces (M8256 and M8029)	20

2 MECHANICAL SERVICING

2.1	General	25
2.2	RX01/RX02 Disk Drive Assembly	26
2.2.1	Rack-Mount	26
2.2.2	Case-Mount	27
2.3	Controller Board	29
2.4	Read/Write Board	30
2.5	Drive	32
2.6	Power Supply	35
2.7	Power Board Assembly (Regulators)	36
2.8	Drive Belt and AC Motor Pulley	37
2.9	Door Handle	38
2.9.1	Door Handle Removal	38
2.9.2	Door Handle Installation	38
2.10	Read/Write Head	39
2.11	Stepper Motor Lead Shaft	39

3 ALIGNMENT AND ADJUSTMENT

3.1	Handle Latch Wire	41
3.2	Drive Belt and AC Motor Pulley	41
3.3	Head Gap	43

APPENDIX A SPARE PARTS LIST

FIGURES

1-1	What System/Subsystem Is This?	3
1-2	Diskette Media	4
1-3	Head Plug (P3) to M7727	7
1-4	Power Supply Voltage Checks	9
1-5	RX8/RX28 Registers	14
1-6	M8357 Interface (RX8/RX28)	16
1-7	RX11/RXV11 Registers	17
1-8	M7846 Interface (RX11)	18
1-9	M7946 Interface (RXV11)	19
1-10	RX211/RXV21 Registers	21
1-11	M8256 Interface (RX211)	23
1-12	M8029 Interface (RXV21)	24
2-1	Subassembly Removal and Replacement	25
2-2	Removing and Replacing RX01/RX02 (Case-Mount)	27
2-3	Controller Board Connections	28
2-4	RX01 Read/Write Board Connections	30
2-5	RX02 Read/Write Board Connections	31
2-6	Plenum/Fan Assembly	33
2-7	Drive and Power Supply Removal	34
2-8	Power Supply Components	35
2-9	Capacitor C1 and C2 Connections	36
2-10	Drive Belt and AC Motor Pulley	37
2-11	Door Handle Assembly	39
2-12	Head Carriage Components (Top View)	40
3-1	Motor Pulley Alignment	41
3-2	Underside View of Drive	42
3-3	Head Gap Adjustment	43
3-4	RX01 Pressure Pad Mechanism (Front View)	44
3-5	RX02 Pressure Pad Mechanism (Front View)	45

TABLES

1-1	Reference Documentation	1
1-2	RX01/RX02 Field Replaceable Units	2
1-3	RX01/RX02 Troubleshooting Chart	3
1-4	Intermittent Problems	7
1-5	Voltages	8
1-6	Diagnostic Error Code Definitions and Probable Causes	10
1-7	Diagnostic Printout Troubleshooting Chart	12
1-8	RX8/RX28 Bootstraps	13
1-9	RX11/RXV11 Bootstrap	16
1-10	RX211/RXV21 Bootstrap	20
2-1	Switch Configuration for M7744	29

1 TROUBLESHOOTING

1.1 GENERAL

This chapter summarizes information on the disk drives, interface boards, and diagnostics for the RX01/RX02 subsystem. For additional information, refer to Table 1-1 for a list of appropriate documents.

NOTE

PDT floppy drives are not included in this document. Refer to the PDT Pocket Service Guide.

Table 1-1 Reference Documentation

Title	Order Number
RX01/RX02 Pocket Service Guide	EK-RX012-PS
RX01/RX02 Reference Card	EK-RX102-RC
RX01/08/11 Maintenance Manual	EK-ORX01-MM
RX02 Floppy Disk System Technical Manual	EK-ORX02-TM
RX8/RX11 RX01 Floppy Disk System	EK-ORX01-OP
RX02 Floppy Disk System Users Guide	EK-ORX02-UG
RXV11 Users Guide	EK-RXV11-OP
RX01/RX02 Customer Equipment Care	EK-RX012-EC
RX01 Floppy Disk IPB	EK-ORX01-IP
RX02 Floppy Disk IPB	EK-ORX02-IP
70-13077 Drive IPB	EK-13077-IP
H771 Power Supply IPB	EK-OH771-IP

The RX01/RX02 subsystem is made of seven field replaceable units (FRUs) plus the chassis and cables. The FRUs and their functions are listed in Table 1-2.

The RX01/RX02 may be in one of several types of subsystem configurations. Figure 1-1 diagrams the most popular configurations.

Parts commonly used in the RX01/RX02 are listed in the Spare Parts List in Appendix A.

1.2 TROUBLESHOOTING CHARTS

Table 1-3 lists the most common failures, their symptoms, and their remedies. Table 1-4 lists intermittent problems that can occur.

NOTE

When troubleshooting, always have the customer duplicate the problem if possible.

Always check all connections before servicing any board or other assemblies.

Table 1-2 RX01/RX02 Field Replaceable Units*

FRU	Function
Drive assembly	Does electromechanical handling of the diskette.
Read/write board	Transfers data, decodes/encodes data, selects drive, controls head positioning.
Controller board	Decodes commands from host and initiates functions.
Interface board	Converts bus signal levels to RX compatible levels. Controls interrupts and transfers commands and data.
Power supply (includes regulator board)	Steps down ac line voltage. Converts ac to dc. Regulates dc. Outputs ac to drive; outputs dc to read/write and controller boards.
Regulator board	Regulates dc voltages. Outputs dc to read/write and controller boards.
Plenum/fan assembly	Cools RX01/RX02 assembly.

* See Appendix A for part numbers.

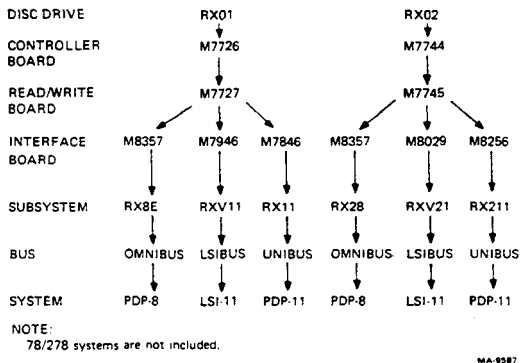

Figure 1-1 What System/Subsystem Is This?

Table 1-3 RX01/RX02 Troubleshooting Chart

Symptom	Possible Cause	Remedy
Door handle not latching properly	Latch wire	Adjust handle latch wire (Paragraph 3.1).
	Handle release button	Install headed-pin pivot (P/N 74-21076).
		Replace door handle.
Both drives inoperative, fan not turning (no indication of power)	Power cord	Check power cord and ac input.
	AC power fuse or circuit breaker	Replace ac power fuse (2.0 A) or reset circuit breaker.

NOTE

To check if diskette (Figure 1-2) is turning, align index hole in diskette with hole in cover. Place in drive and close cover. Then, remove diskette. If holes are still aligned, diskette is not turning.

Table 1-3 RX01/RX02 Troubleshooting Chart (Cont)

Symptom	Possible Cause	Remedy
---------	----------------	--------

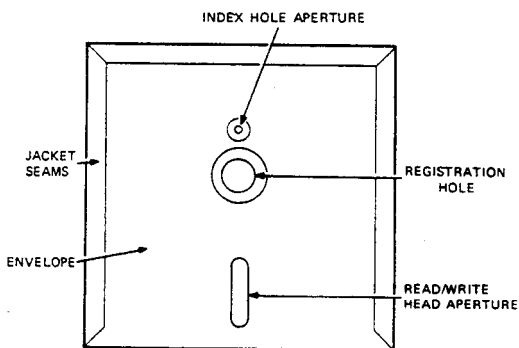

MA-1780A

Figure 1-2 Diskette Media

Diskette not turning	Belt	Replace belt (Paragraph 2.8).
	Drive power plug	Check plug connection to drive (Figure (2-7)).
	Power supply	Check voltages (Paragraph 1.2).
	Drive motor	Replace drive (Paragraph 2.5).
Both drives fail to initialize	Host	Make sure host is interacting with other I/O devices.
	Interface/ interface cable	Check connection and polarity of cable with host. Replace interface cable.
	Power supply	Check voltages (Paragraph 1.2).

Table 1-3 RX01/RX02 Troubleshooting Chart (Cont)

Symptom	Possible Cause	Remedy
	Configuration (RX02 only)	Set switches on controller board to correct position (Table 2-1).
	Interface board	Replace interface board.

CAUTION

Do not short out a board. When checking read/write or controller board, place insulating material on top of existing board and temporarily cable board in place. Remove board only when verified as faulty.

	Controller board	Replace board (Paragraph 2.3).
	Read/write board	Replace board (Paragraph 2.4).
One drive fails to initialize	Drive power connector	Check connector (Figure 2-7).

NOTE

In the RX02 unit, interchange all cables of drives 0 and 1 (Figure 2-5). If symptom appears on other drive, substitute boards to determine defective board (Paragraphs 2.3 and 2.4). If symptom remains on original drive, replace drive mechanism (Paragraph 2.5).

	Read/write board	Replace board (Paragraph 2.4).
	Read/write to controller cable	Replace cable.
	Controller board	Replace board (Paragraph 2.3).
	Drive	Replace drive (Paragraph 2.5).

Table 1-3 RX01/RX02 Troubleshooting Chart (Cont)

Symptom	Possible Cause	Remedy
NOTE Diagnostics should boot in drive 0 and 1 of unit A. Host software may not.		
Program cannot be booted or run from either drive.	Diskette	Replace diskette.
	Controller board	Replace board (Paragraph 2.3).
	Interface cable	Replace cable.
	Read/write board	Replace board (Paragraph 2.4).
	Read/write to controller cable	Replace cable.
Diagnostics boot in one drive only	Read/write board	Replace board (Paragraph 2.4).
	Drive	Replace drive (Paragraph 2.5).
Diagnostics boot but will not run	Diagnostic	Use correct diagnostics (Paragraphs 1.3 through 1.5).
	Load error	Reload diagnostic using second drive.
	Controller board	Replace board (Paragraph 2.3).
	Interface board	Replace interface.
	Interface cable	Replace cable.
Diagnostics run with errors	Subsystem	Look up errors in Tables 1-6 and 1-7.
Diagnostics run okay but intermittent errors persist	Subsystem	Go to Table 1-4.

Table 1-4 Intermittent Problems

Symptom	Possible Cause	Remedy
Errors with read/write data functions	Read/write head plug (P3)	Install resistor assembly (P/N 70-16263). The resistor assembly must always be installed when using M7726 and M7727 boards (Figure 1-3).

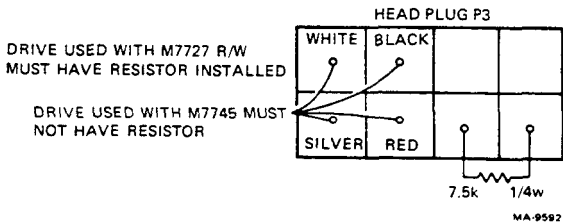
**Figure 1-3 Head Plug (P3) to M7727**

	Metal read/write head	If subsystem has one drive with a metal head and one with a ceramic head, replace drive with metal head.
Seek errors	Stepper motor lead shaft	Clean shaft with alcohol and regrease (Paragraph 2.11).
	Stepper motor burning etch	Stepper motor can cause burning or discoloration around transistors in rear corners of board. Replace drive and read/write board. (Paragraphs 2.4 and 2.5).
Diskettes do not recopy but appear okay	Faulty write current	Replace read/write board (Paragraph 2.4). Replace controller board (Paragraph 2.3).
Any symptom	Interface cable	Reinsert cable.

Table 1-4 Intermittent Problems (Cont)

Symptom	Possible Cause	Remedy
Any symptom	Interface cable	Replace cable.
	Controller to read/write cable	Reinsert cable.
		Replace cable.
	Connectors P3 through P7 (Figures 2-4 and 2-5)	Reinsert connectors. No brass Female ends should push out of plastic plugs.
Hold-down screw shorting to board	Install nylon washers on any hold-down screw near the board etch.	

1.3 POWER SUPPLY VOLTAGES

Use Table 1-5 and Figure 1-4 for all dc voltage checks. There are no adjustments. If voltages are incorrect, replace the power board (Paragraph 2.7) or the power supply (Paragraph 2.6).

Table 1-5 Voltages*

Pin	Voltage	Purpose
Connection P2 to J4/J3 (power board to controller board)		
1	+9.5 Vdc†	Initializes
2		No connection
3		Ground
4	+5 Vdc	Powers logic signal
5		Ground
6		No connection
Connection P1 and J2 (power board to read/write board)		
1		No connection
2	-5 Vdc	Powers analog IC
3		Ground
4	+5 Vdc	Powers logic signal
5	0.V	+24 V return
6	+24 Vdc	Powers stepper motor, erase and write current, head-load solenoid

* Use with Figure 1-4.

† Some documents wrongly state 10 V.

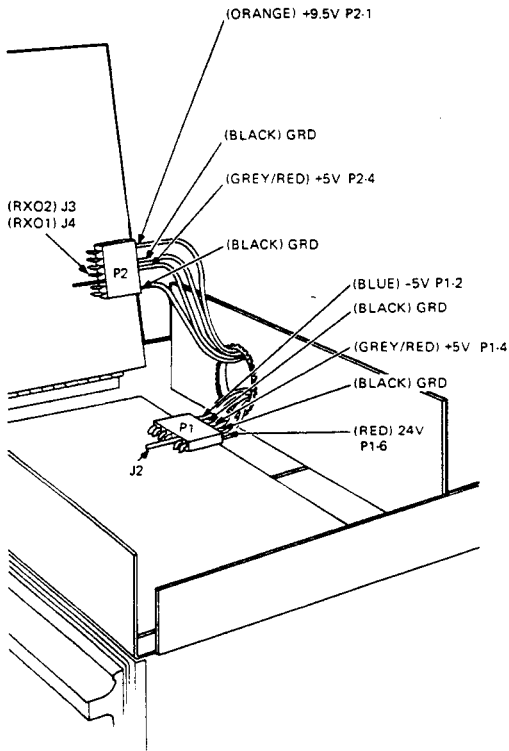

MA 41458

Figure 1-4 Power Supply Voltage Checks

1.4 RX8/RX28 SUBSYSTEM

Use this information for diagnostics, installations, and troubleshooting. Table 1-1 lists documents with additional information. The RX8/RX28 subsystem has two diagnostics.

- AIRXA(x) functional test
- AIRXB(x) performance exerciser*

Make sure the revision level of the diagnostic and diagnostic writeup are the same. Tables 1-6 and 1-7 are for use with diagnostic error printouts.

*The symbol (x) represents the revision level.

Table 1-6 Diagnostic Error Code Definitions and Probable Causes

Code	Definition	Causes
0010	Drive 0 failed to see home on initialize.	Drive Controller R/W electronics
0020	Drive 1 failed to see home on initialize.	Drive Controller R/W electronics
0030*	Found home when stepping in 10 tracks for init.	Drive Controller R/W electronics
0040	Tried to access a track greater than 76 (decimal).	Interface module Controller
0050	Home was found before desired track was reached.	R/W electronics Drive Controller
0060*	Self diagnostic error (Init).	Controller Cables Interface module
0070	Desired sector not found after looking at 52 headers (2 revolutions).	Diskette R/W electronics Drive Controller Interface module
0100*	Write command on a write-protected drive.	R/W electronics Controller
0110	More than 40 μ s and no SEP clock seen.	Diskette R/W electronics Drive Controller
0120	A preamble not found.	Diskette R/W electronics Drive Controller Power supply Interface module
0130	Preamble found but no ID mark found in time.	Diskette R/W electronics Controller

Table 1-6 Diagnostic Error Code Definitions and Probable Causes (Cont)

Code	Definition	Causes
0140*	CRC error on a header but error not asserted.	Controller Cables Interface module
0150	Good header track address does not compare with desired track.	R/W electronics Drive Controller
0160	Too many tries for an IDAM (identifies header).	R/W electronics Drive Controller
0170	Data AM not found in time.	Diskette R/W electronics Controller
0200	CRC error on reading the sector from disk. No code appears in ERREG.	Diskette R/W electronics Controller
0210*	Parity error on a word from I/F to controller.	Controller Interface module Cables
0220†	R/W electronics failed maintenance mode test.	R/W electronics Controller
0230†	Word count overflow.	Interface module Controller
0240†	Density error.	Diskette Controller Interface module R/W electronics
0250†	Wrong key word for set media density command.	Interface module Controller

* RX01 only

† RX02 only

Table 1-7 Diagnostic Printout Troubleshooting Chart

Symptom	Possible Cause	Remedy
Done bit timeout	Configuration (RX02 only)	Set switches (Table 2-1).
	Interface board	Replace board.
TR bit timeout	Controller board	Replace board (Paragraph 2.3).
	Interface board	Replace board.
Set density error	Diskette	Replace diskette.
	Controller board	Replace board (Paragraph 2.3).
	Read/write board	Replace board (Paragraph 2.4).
Data error but no CRC error	Controller board	Replace board (Paragraph 2.3).
	Interface board	Replace board.
Fill buffer error	NPR jumper	Cut jumper on PDP-11 backplane RX211.
Empty buffer error	Interface board	Replace board.
	Controller board	Replace board (Paragraph 2.3).
Unexpected interrupt to location XXX	Interface board	Set switches correctly.
		Replace board.

1.4.1 Bootstrap

When a front panel is available, use toggle-in routines (Table 1-8) to boot the floppy.

1.4.2 Registers

The RX8/RX28 registers are broken down in Figure 1-5.

Table 1-8 RX8/RX28 Bootstraps

RX8		RX28	
Location	Instruction	Location	Instruction
24	7126	20	1061
25	1060	21	1046
26	67x1	22	0060
27	7201	23	3061
30	4053	24	7327
31	4053	25	1061
32	7104	26	67x1
33 (START)	67x5	27	7301
34	5054	30	4053
35	67x4	31	4053
36	7450	32	7004
37	7610	33 (START)	67x5
40	5046	34	5054
41	1060	35	67x4
42	7041	36	7450
43	1061	37	5020
44	3060	40	1061
45	5024	41	67x1
46	67x1	42	1061
47	4053	43	0046
50	3002	44	1032
51	2050	45	3060
52	5047	46	0360
53	0000	47	4053
54	67x3	50	3002
55	5033	51	2050
56	67x2	52	5047
57	5453	53	0000
60	7024	54	67x3
61	6030	55	5033
		56	67x2
		57	5453
		60	0420
		61	0020

COMMAND AND STATUS REGISTER

RXCS, PDP-8, RX01 67X1

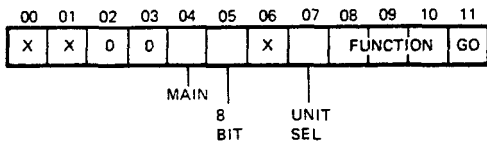

RX2CS, PDP-8, RX02 67 X 1

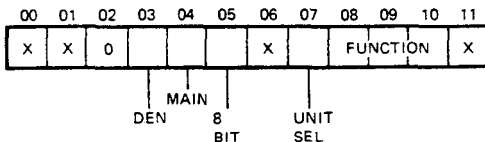

FUNCTION CODES

000 FILL BUFFER	100 NOT USED (RX01)
001 EMPTY BUFFER	SET DENSITY (RX02)
010 WRITE SECTOR	101 READ RXES
011 READ SECTOR	110 WRITE WITH DEL DATA MARK
	111 READ ERROR REG

ERROR AND STATUS REGISTER (StatusA)

RXES, PDP-8, RX01 67X2

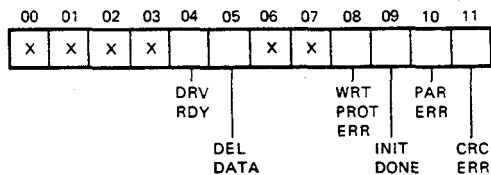

RX2ES, PDP-8, RX02 67 X 2

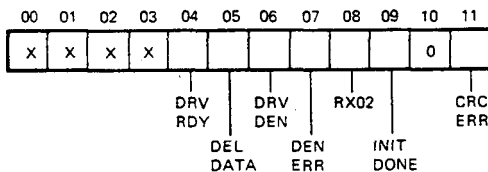

MA-9597

Figure 1-5 RX8/RX28 Registers (Sheet 1 of 2)

TRACK ADDRESS REGISTER

RXTA, RX2TA, PDP-8, RX01/02 67X2

00	01	02	03	04	05	06	07	08	09	10	11	
X	X	X	X	0	TRACK ADDRESS						0	114 ₈

DATA BUFFER REGISTER

RXDB, PDP-8, RX01/RX02 67X2

00	01	02	03	04	05	06	07	08	09	10	11
DATA - 12 BIT MODE ONLY				DATA BYTE							

SECTOR ADDRESS REGISTER

RXSA, RX2SA, PDP-8, RX01/02 67X2

00	01	02	03	04	05	06	07	08	09	10	11
X	X	X	X	0	0	0	SECTOR ADDRESS				32 ₈

MA-9598

Figure 1-5 RX8/RX28 Registers (Sheet 2 of 2)

1.4.3 Interface (M8357)

Use the M8357 board (Figure 1-6) for both RX01s and RX02s when they are connected to PDP-8 systems. Device code switch settings are the same whether the interface is on an RX8 or RX28 subsystem.

NOTE

RX01/RX02 interfacing to 78/278 series computers is part of the CPU.

1.5 RX11/RXV11 SUBSYSTEM

Use this information for diagnostics, installations, and troubleshooting. Table 1-1 lists documents with additional information. The RX11/RXV11 subsystem has two diagnostics.

ZRXA(x) system reliability test
ZRXB(x) interface diagnostic*

Make sure the revision level of the diagnostic and diagnostic writeup are the same. Use Tables 1-6 and 1-7 with error printouts.

*The symbol (x) represents the revision level.

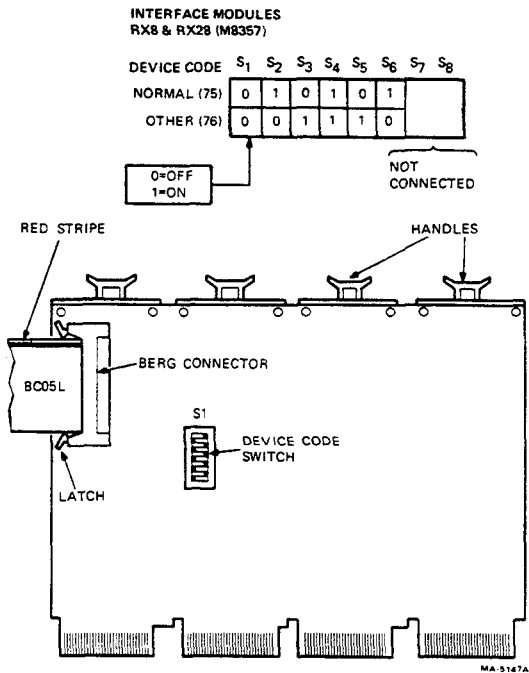

Figure 1-6 M8357 Interface (RX8/RX28)

1.5.1 Bootstrap

When a front panel is available, use a toggle-in routine (Table 1-9) to boot the floppy.

1.5.2 Registers

The RX11/RXV11 registers are broken down in Figure 1-7.

Table 1-9 RX11/RXV11 Bootstrap

Location	Instruction	Location	Instruction
1000	005000	1022	100405
1002	012701	1024	105711
1004	177170	1026	100004
1006	105711	1030	116120
1010	001776	1032	000002
1012	012711	1034	000770
1014	000003	1036	000000
1016	005711	1040	005000
1020	001776	1042	000110

ZRXD(x) RX02 performance exerciser
 ZRXF(x) RX02 function/logic
 ZRXC(x) RX02 utility driver (Brutus)
 ZRXE(x) RX02 formatter program*

Field Service requires ZRXD and ZRXF only. ZRXC is primarily an engineering tool. ZRXE sets media density only and does not write headers. Make sure the revision level of the diagnostic and diagnostic writeup are the same. Use Tables 1-6 and 1-7 with error printouts.

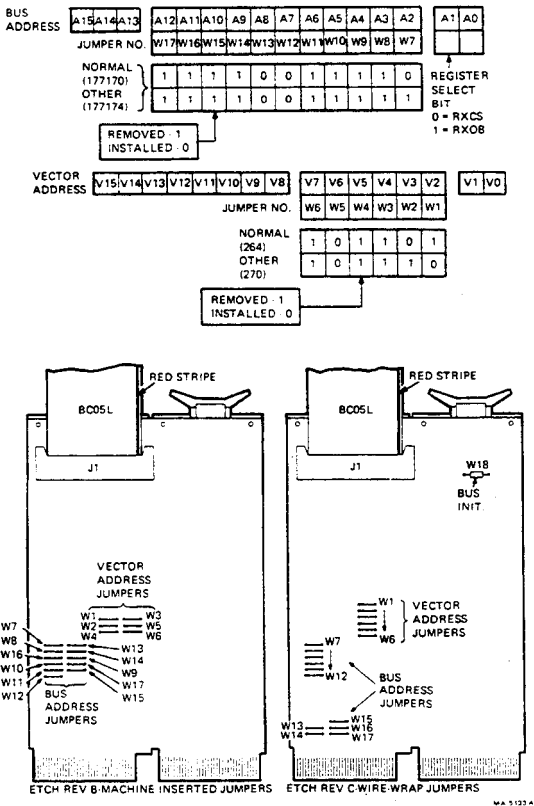

Figure 1-9 M7946 Interface (RXV11)

*The symbol (x) represents the revision level.

1.6.1 Bootstrap

When a front panel is available use a toggle-in routine (Table 1-10) to boot the floppy.

1.6.2 Registers

The RX211/RXV21 registers are broken down in Figure 1-10.

1.6.3 Interfaces (M8256 and M8029)

Use the M8256 (RX211) and M8029 (RXV21) boards with RX02s only. Figures 1-11 and 1-12 show normal bus and vector addresses.

Table 1-10 RX211/RXV21 Bootstrap

Location	Instruction	Location	Instruction
2000	012701	2060	000304
2002	177170	2062	030011
2004	012700	2064	001776
2066	100240	2056	100422
2010	005002	2070	012711
2012	012705	2072	000403
2014	000200	2074	030011
2016	012704	2076	001776
2020	000401	2100	100415
2022	012703	2102	010513
2024	177172	2104	030011
2026	030011	2106	001776
2030	001776	2110	100411
2032	100440	2112	010213
2034	012711	2114	060502
2036	000407	2116	060502
2040	030011	2120	122424
2042	001776	1211	120427
2044	100433	2124	000007
2046	110413	2126	003737
2050	000304	2130	005000
2052	030011	2132	005007
2054	001776	2134	000000
2056	110413		

COMMAND AND STATUS REGISTER

RX2CS, PDP-11/LSI-11, RX02 177170

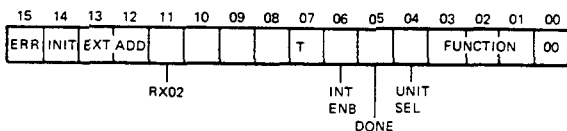

FUNCTION CODES

000 FILL BUFFER	101 READ RXES
001 EMPTY BUFFER	110 WRITE WITH DEL DATA MARK
010 WRITE SECTOR	111 READ ERROR REG
011 READ SECTOR	
100 NOT USED (RX01)	
SET DENSITY (RX02)	

ERROR AND STATUS REGISTER (STATUS A)

RX2ES, PDP-11/LSI-11, RX02 177172

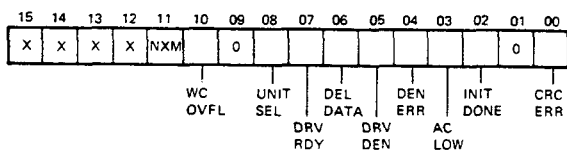

SECTOR ADDRESS REGISTER

RX2SA, PDP-11/LSI-11 RX01/02 177172

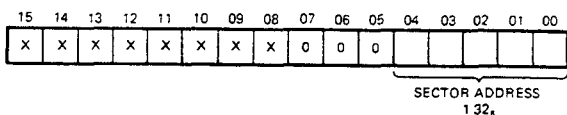

TRACK ADDRESS REGISTER

RX2TA, PDP-11/LSI-11 RX01/02 177172

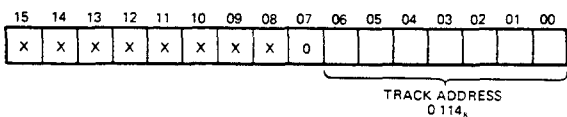

MA 9589

Figure 1-10 RX211/RXV21 Registers (Sheet 1 of 2)

WORD COUNT REGISTER

RX2WC, PDP-11/LSI-11, RX02 ONLY 177172

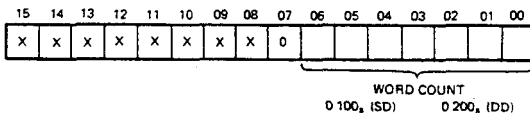

BUS ADDRESS REGISTER

RX2BA, PDP-11/LSI-11, RX02 ONLY 177172

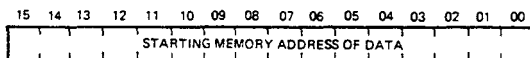

ERROR CODES

ERR REG				PDP 11, LSI 11				RX02 ONLY					
TRACK ADDR SEL DV				DV SEL	DEN DV1	HD LD	DEN DVO				DEN CMD	WORD 4	
TARGET SECTOR				TARGET TRACK									
CURRENT TRACK DV1				CURRENT TRACK DV0									
WORD COUNT REG				ERROR CODE									
15				8 7				4				0	WORD 1

MA 9580

Figure 1-10 RX211/RXV21 Registers (Sheet 2 of 2)

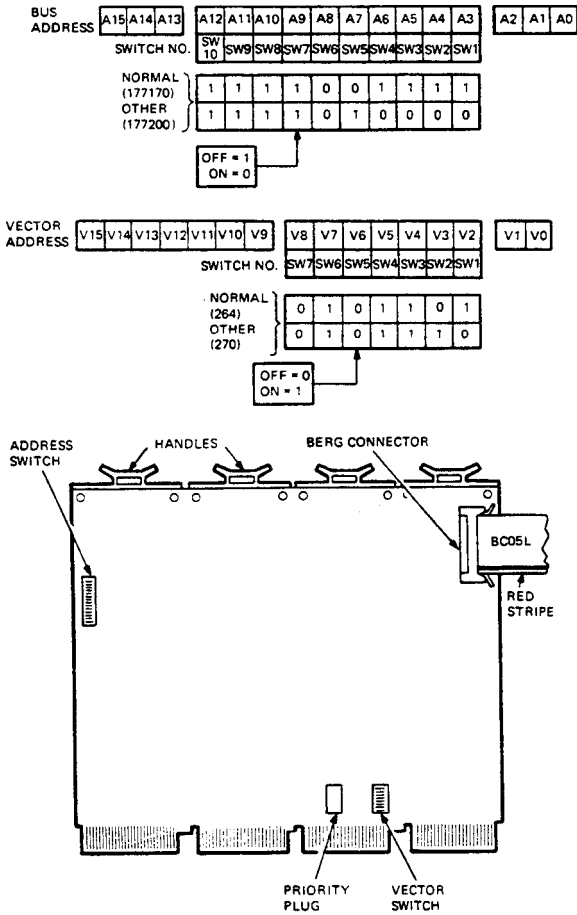
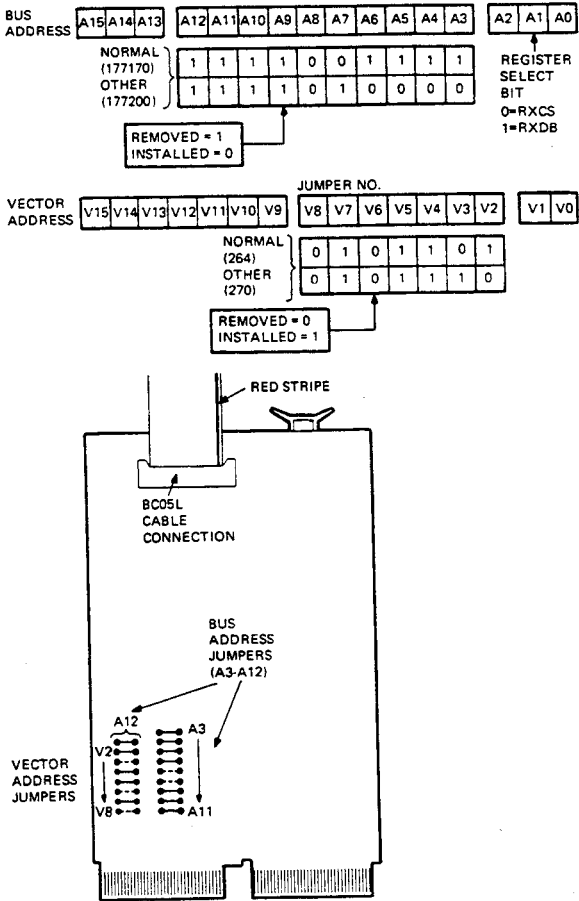

Figure 1-11 M8256 Interface (RX211)



MA 5132A

Figure 1-12 M8029 Interface (RXV21)

2 MECHANICAL SERVICING

2.1 GENERAL

This chapter describes the removal, replacement, and cleaning of RX01/RX02 assemblies, boards, and field replaceable components. Figure 2-1 shows the order in which units must be removed and provides convenient references to the appropriate paragraphs.

WARNING

Before attempting to remove or replace any assemblies, disconnect all power plugs and interface cables.

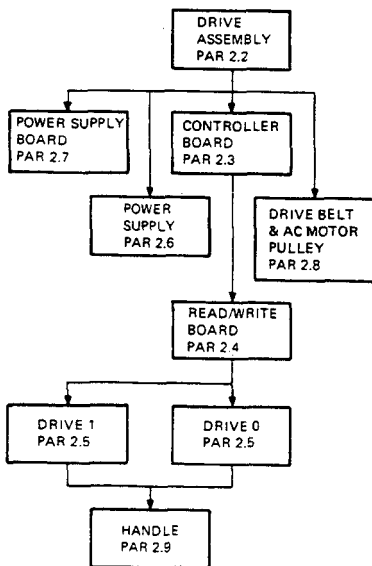

MA-41468

Figure 2-1 Subassembly Removal and Replacement

2.2 RX01/RX02 DISK DRIVE ASSEMBLY

Use the following procedures to remove the entire disk drive assembly from a system. Paragraph 2.2.1 applies to an RX01/RX02 mounted in a rack, and Paragraph 2.2.2 applies to an RX01/RX02 mounted in a case.

NOTE

Some RX01s and RX02s are mounted in other type cabinets. Refer to the appropriate system documentation in these cases.

2.2.1 Rack-Mount

Perform the following procedure to remove and install a rack-mounted RX01/RX02.

WARNING

Disconnect the power cable from the prime power source and the interface cable from the host before attempting to remove the RX01/RX02.

The disk drive assembly weighs approximately 65 pounds. Lifting the unit requires two people to avoid personal injury or equipment damage.

1. Disconnect power to the system.
2. Slide unit so that it is extended in the rack.
3. Disconnect the ac power cord from the host system.
4. Disconnect the interface cable from the interface board.
5. Remove any cable clamps holding the interface cable.
6. Carefully remove the RX01/RX02 from the rack by pressing in on the stop tabs. In some versions, eight screws on the side rails must be removed first.
7. Install the RX01/RX02 assembly by reversing steps 1 through 6.

2.2.2 Case-Mount

Perform the following procedure to remove and install a case-mounted RX01/RX02. Refer to Figure 2-2.

WARNING

Disconnect the power cable from the prime power source and the interface cable from the host before attempting to remove the RX01/RX02.

The disk drive assembly weighs approximately 65 pounds. Lifting the unit requires two people to avoid personal injury or equipment damage.

1. Disconnect the power and interface cables from the rear of the RX01/RX02 (Figure 2-2).
2. Remove mounting screws if present.
3. Slide the unit from the mini-desk.

NOTE

When replacing the unit in the mini-desk, brace the desk against the wall to prevent it from rolling.

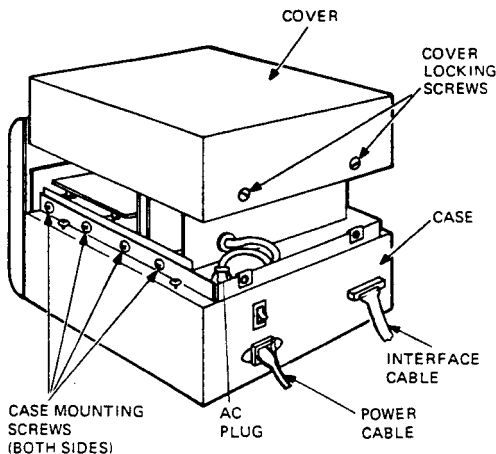

MA-41548

Figure 2-2 Removing and Replacing RX01/RX02 (Case-Mount)

4. Turn the two cover-locking screws on the back of the unit 1/4-turn counterclockwise (Figure 2-2).
5. Slide the top cover backwards and lift it straight up.
6. Remove the four case-mounting screws on each side of the case (Figure 2-2).
7. Remove the ac plug from the receptacle in the rear of the case.
8. Remove the three screws securing the controller to the chassis. Note the position of any nylon washer. Swing the board upright. Remove connector J1 of the interface cable from the controller board (Figure 2-3). Swing the board down.
9. Slide the chassis forward and remove it from the case.
10. Install the RX01/RX02 assembly by reversing steps 1 through 9.

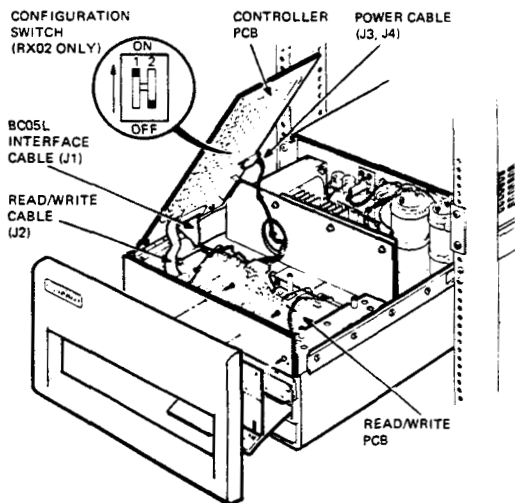

MA-5144B

Figure 2-3 Controller Board Connections

2.3 CONTROLLER BOARD

Perform the following procedure to remove and install the controller board. Refer to Figure 2-3.

1. Perform steps 1 through 5 in Paragraph 2.2.1 (rack-mount) or steps 1 through 6 in Paragraph 2.2.2 (case-mount).
2. Remove the three screws securing the controller to the chassis. Note the position of any nylon washer. Swing the board upright.
3. Remove J1, J2, and either J4 (RX01) or J3 (RX02) from the controller board.
4. Remove the three nuts (not the screws) securing the controller board to the hinge assembly. Remove the board.
5. If the controller is an RX02, make the proper switch settings on the new controller board (Figure 2-3). Refer to Table 2-1.

NOTE

When replacing the controller board, transfer the nuts and washers to the new board to act as spacers between the hinge and board.

6. Install the controller board and the RX01/RX02 assembly by reversing steps 1 through 5.

Table 2-1 Switch Configuration for M7744

System Designation	RX01 S1-1	DMA S1-2	Function
RX211, RXV21	Off	On	RX02 operates as RX02 (PDP-11, LSI-11), DMA.
RX8E, RX11, RXV11	On	Off	RX02 operates as RX01 (PDP-8, PDP-11, LSI-11), programmed I/O.
RX28	Off	Off	RX02 operates as RX02 (PDP-8), programmed I/O.

2.4 READ/WRITE BOARD

Perform the following procedure to remove and install the read/write board. Refer to Figures 2-4 and 2-5.

NOTE

When replacing a read/write board, check the etch for burn or discoloration. This may be most visible around the four transistors in both rear corners of the board. Replace the drive as well as the board if this occurs.

1. Perform steps 1 and 2 in Paragraph 2.3.
2. Remove all connectors for both drives (Figure 2-4 or 2-5).
3. Remove the eight screws and washers securing the read/write board to the chassis. (Note the position of the nylon washer if applicable.)

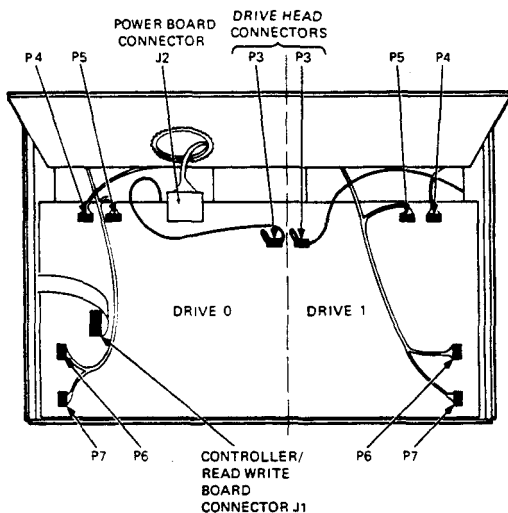

COLOR CODE

P7 - BLUE, GREEN, BLACK, GRAY (HOME PHOTOSENSOR)

P6 - BLACK, WHITE, BLUE, GRAY (INDEX PHOTOSENSOR)

P5 - GRAY, BLUE (HEAD LOAD SOLENOID)

P4 - YELLOW, RED, GRAY, BROWN, BLACK (STEPPER MOTOR)

MA-4155B

Figure 2-4 RX01 Read/Write Board Connections

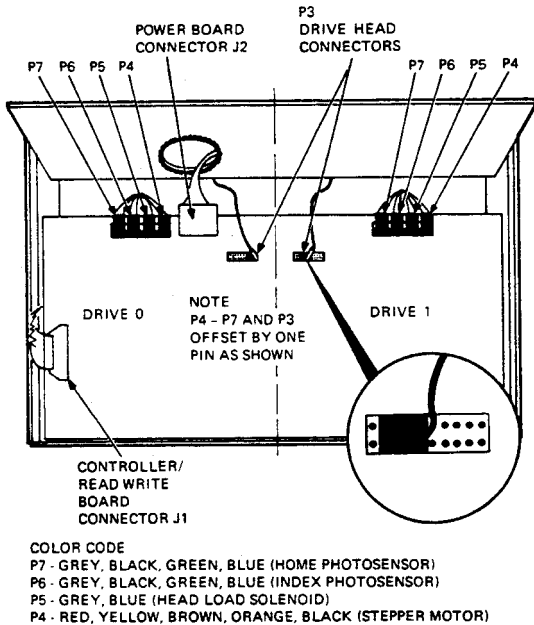

Figure 2-5 RX02 Read/Write Board Connections

CAUTION

When you reinstall the board, make sure the screw and the nylon washer that insulates the screw from the circuitry are in the correct location.

4. Install the read/write board and the RX01/RX02 assembly by reversing steps 1 through 3. Connect the power supply and drive connectors as shown in Figure 2-4 (RX01) or Figure 2-5 (RX02).

NOTE

Connector P3 can be reversed, but the positioning of the connector on the board is important.

2.5 DRIVE

Perform the following procedure to remove and install the drive.

1. Perform steps 1 and 2 in Paragraph 2.3.
2. Unplug all drive connectors from the read/write board of the drive in question.
3. Remove the head cable from the head cable clamp.

NOTE

The following two steps apply only to the case-mounted RX01/RX02.

4. Swing the controller board down. Secure it with one of the screws removed in step 1.
5. Set the RX01/RX02 on its side.
6. If necessary, remove the screws securing the plenum/fan assembly to the rear of the RX01/RX02 (Figure 2-6).

NOTE

Some early rack-mounted RX01s do not have a plenum/fan assembly. Retrofit any units found this way.

7. Disconnect the drive power connector from the rear of the drive (Figure 2-7).

CAUTION

Close the drive door before attempting to remove the drive unit. Support the drive assembly during the next step. It can fall out of the chassis at this point.

8. Remove the screw holding the controller board. Remove the six drive screws securing the drive assembly to the chassis (three on each side) (Figure 2-7). Remove the drive unit.
9. Install the drive and RX01/RX02 assembly by reversing steps 1 through 8.

NOTE

If using the M7727 read/write board, install the resistor assembly in head plug P3 (Figure 1-3).

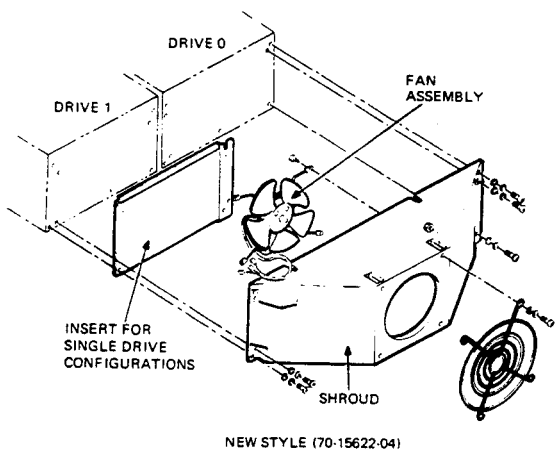
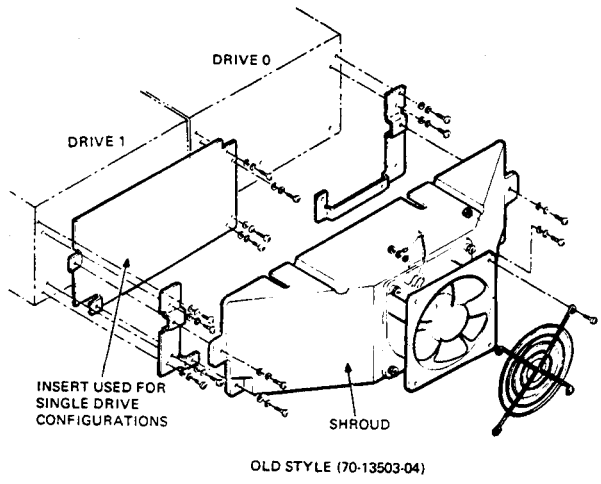

MA-5141A

Figure 2-6 Plenum/Fan Assembly

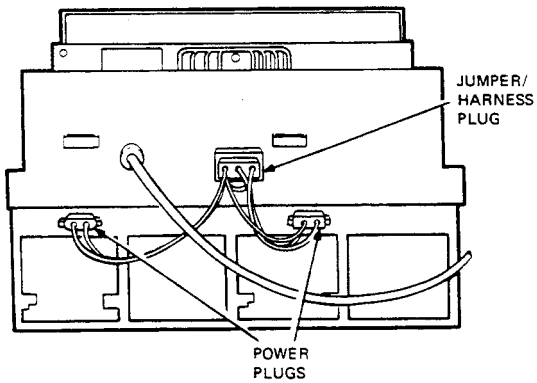
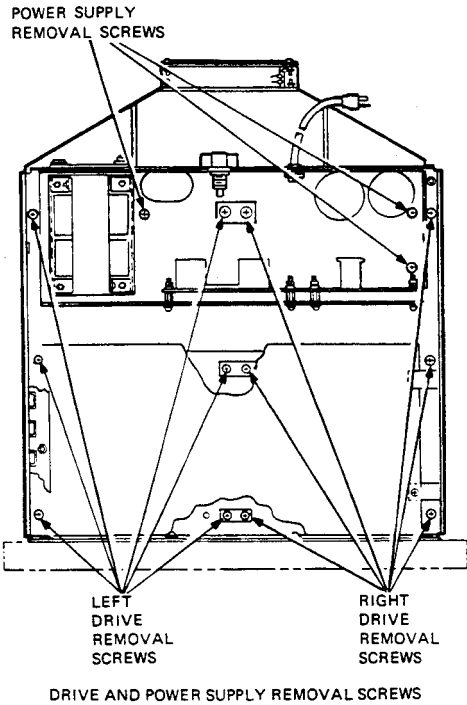

Figure 2-7 Drive and Power Supply Removal

2.6 POWER SUPPLY

Perform the following procedure to remove and install the power supply. Refer to Figure 2-8 and 2-9.

1. Perform steps 1 and 2 in Paragraph 2.3.

WARNING

Before attempting to remove the power supply, disconnect power from the drive. Then short out the two terminals on capacitors C1 and C2 (Figure 2-9).

2. Remove the jumper/harness plug from the rear of the power supply (Figure 2-8).
3. Remove the power board connectors from J2 on the read/write board and J3/J4 on the controller board (Figures 2-3 and 2-4).
4. Remove the interface cable clamp if applicable (Figure 2-8).
5. Remove the three power supply screws and washers securing the power supply to the RX01/RX02 chassis (Figure 2-7).
6. Lift the power supply free from the chassis.
7. Install the power supply and the RX01/RX02 assembly by reversing steps 1 through 6.

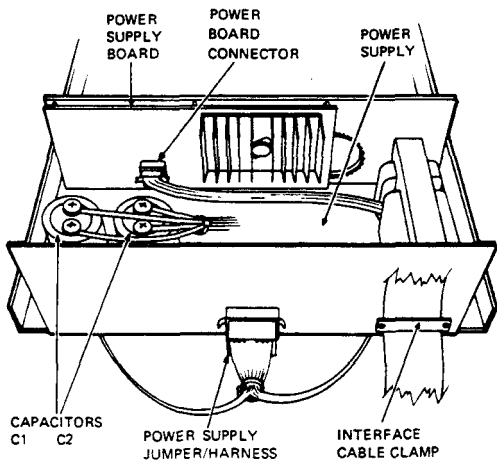

MA-41588

Figure 2-8 Power Supply Components

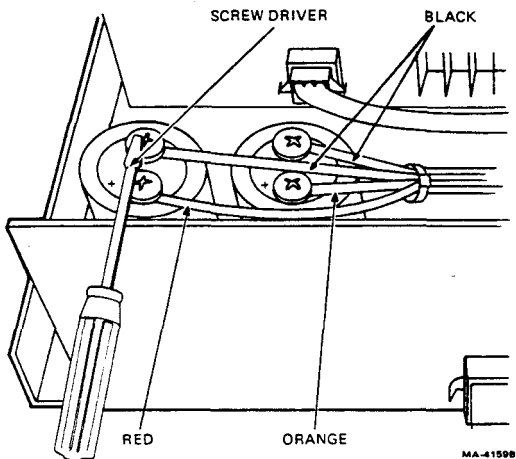

Figure 2-9 Capacitor C1 and C2 Connections

2.7 POWER BOARD ASSEMBLY (REGULATORS)

Perform the following procedure to remove and install the power board assembly. Refer to Figures 2-8 and 2-9.

1. Perform steps 1 and 2 in Paragraph 2.3.

WARNING

Before attempting to remove the power supply, disconnect power from the drive. Then short out the two terminals on capacitors C1 and C2 (Figure 2-9).

2. Disconnect the connector from the center of the power supply board (Figure 2-8).
3. Remove the power board connectors from J2 on the read/write board and J3/J4 on the the controller board (Figures 2-3 and 2-4).
4. Note the polarity of the leads on capacitors C1 and C2, and then remove the leads (Figure 2-8).
5. Remove the six screws securing the board to the power supply and remove the board. When installing, be careful not to tighten the screws too much.

CAUTION

Observe the correct polarity when connecting the wires to C1 and C2 (Figure 2-9).

6. Install the power board assembly and the RX01/RX02 assembly by reversing steps 1 through 5.

2.8 DRIVE BELT AND AC MOTOR PULLEY

Perform the following procedure to remove and install the drive belt and ac motor pulley.

1. Perform steps 1 and 2 in Paragraph 2.2.1 (rack-mount) or steps 1 through 10 in Paragraph 2.2.2 (case-mount).
2. Set the RX01/RX02 on its side (case-mount only). Remove the screws securing the bottom cover of the appropriate drive assembly. Remove the cover.
3. While turning the spindle pulley, remove the belt by rolling it off the spindle pulley (Figure 2-10).

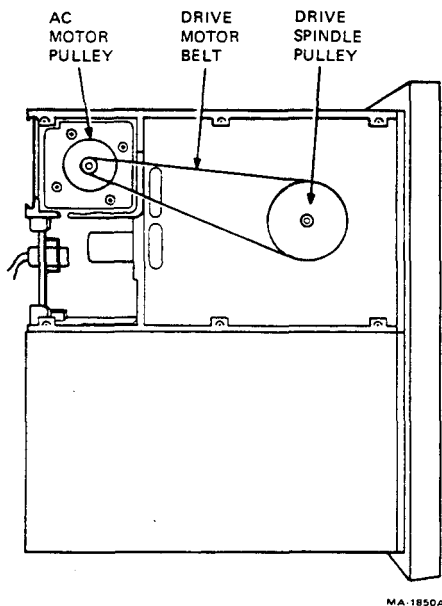

Figure 2-10 Drive Belt and AC Motor Pulley

NOTE

If the belt has fallen off, replace the ac motor pulley. If the belt is simply worn, go to step 6.

Replace the defective belt and pulley with the proper parts. See Appendix A for the correct part numbers.

4. Using a 1/16-inch Allen wrench, loosen the 6-32 set screw securing the pulley to the motor. Remove the pulley.
5. Place the new flanged pulley on the shaft.
6. Clean the face of the pulleys with alcohol.
7. Adjust pulley position and belt tension according to Paragraph 3.2.
8. Install the RX01/RX02 assembly by reversing steps 1 through 3.

2.9 DOOR HANDLE

Perform the following procedures to remove and install the door handle.

2.9.1 Door Handle Removal

1. Remove the drive assembly according to Paragraph 2.5.
2. Remove the two mounting screws securing the handle to the hinged cover (Figure 2-11). Hold the cover securely to prevent it from suddenly springing up.
3. Remove the handle by pulling it through the opening in the front panel.

2.9.2 Door Handle Installation

1. Insert the handle through the front panel and install the mounting screws, (Figure 2-11). Do not tighten the screws completely.
2. Adjust the handle so that the handle brackets do not rub on the front panel. Latch the handle.
3. Tighten the mounting screws.
4. Check the head gap clearance according to Paragraph 3.3. Do the adjustment if necessary.
5. Check again for freedom of movement. Install the drive according to Paragraph 2.5. Begin with step 9.

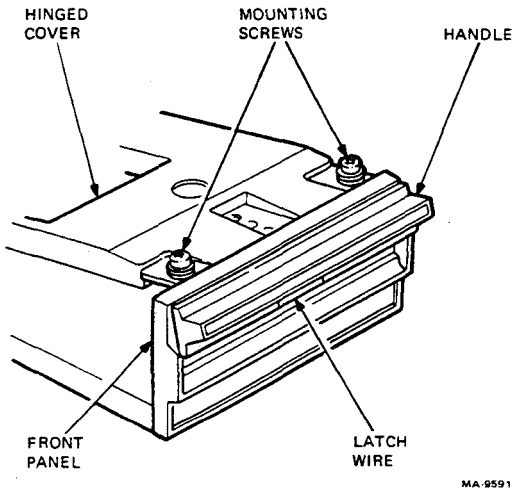

MA-9591

Figure 2-11 Door Handle Assembly

2.10 READ/WRITE HEAD

Perform the following procedure to clean the read/write head.

NOTE

Clean the read/write head only when error symptoms occur.

1. To reach the read/write head, remove the drive (Paragraph 2.5) or the read/write board (Paragraph 2.4).
2. Lift the pressure pad assembly (Figure 2-12). Clean the head with magnetic head-cleaner.
3. Install the unit by reversing step 1.

2.11 STEPPER MOTOR LEAD SHAFT

Perform the following procedure to clean the head shaft.

NOTE

Clean the head shaft only when error symptoms occur.

1. Remove the drive according to Paragraph 2.5.

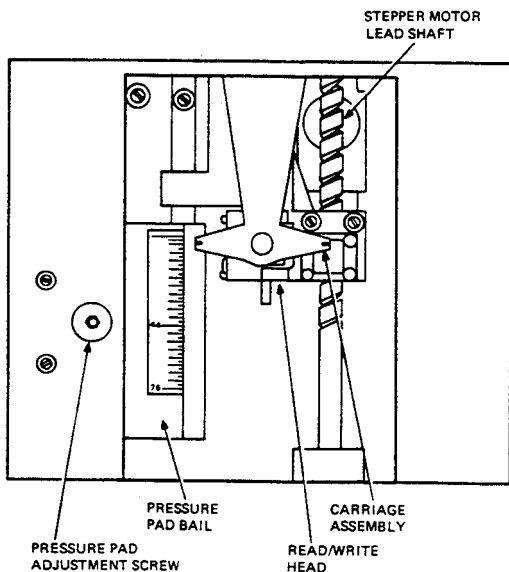

MA-0683A

Figure 2-12 Head Carriage Components
(Top View)

2. Clean the shaft (Figure 2-12) with alcohol while moving the carriage assembly in and out by hand-turning the shaft.
3. Add a little grease to the shaft. Use only molybium grease (lithium base, grade #2).
4. Install the drive according to Paragraph 2.5. Begin with step 9.

3 ALIGNMENT AND ADJUSTMENT

3.1 HANDLE LATCH WIRE

Adjust the handle latch wire (Figure 2-11) so that it firmly holds the handle latch. The wire must not rub against the latch when the handle is pushed past the latched position. To adjust the handle latch wire properly, perform the following steps.

1. Pull the latch wire out by placing a screwdriver between the wire and the front panel. Pry one side at a time until the wire firmly holds the handle latch.
2. Pull the latch wire in by tapping the wire loop on one side at a time. Do this until it does not rub the handle latch when the handle is pushed past the latched position.

3.2 DRIVE BELT AND AC MOTOR PULLEY

Perform the following procedure to adjust the drive belt and ac motor pulley.

1. Remove the drive belt and ac motor pulley according to Paragraph 2.8.
2. Using a straight edge, make sure the motor pulley aligns with the spindle pulley (Figure 3-1).

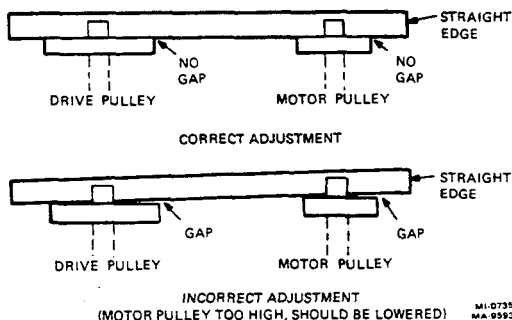

Figure 3-1 Motor Pulley Alignment

CAUTION

Misadjustment of the drive pulley causes the belt to fly off the pulley.

3. Tighten the set screw on the flat of the motor shaft.
4. Use the spacer gauge to check for correct spacing between the pulleys. This is critical for proper belt tension. When the motor and spindle pulleys hold the spacer gauge in place, the spacing is correct (Figure 3-2).

NOTE

Each type of drive has a different spacer gauge. Use the correct gauge (Appendix A).

5. If the spacing is wrong, loosen the four motor-mounting screws (Figure 3-2). Adjust the position of the motor for correct spacing and tighten the four screws.

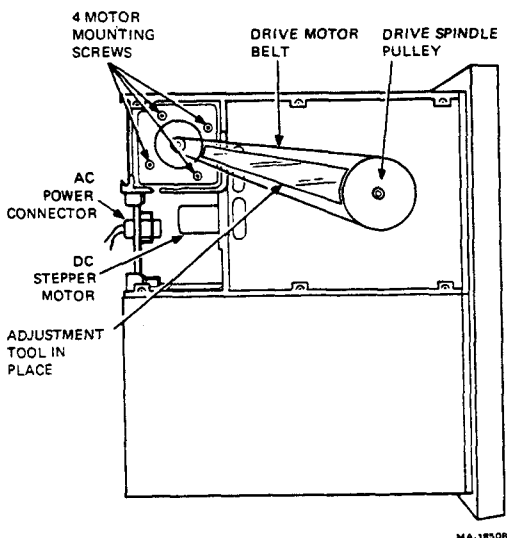

Figure 3-2 Underside View of Drive

6. Install the belt by rolling it onto the large spindle pulley.

CAUTION

Do not stretch the belt onto the pulley. It is nylon, not rubber. Stretching breaks nylon fibers and damages the belt.

7. Return to Paragraph 2.8.

3.3 HEAD GAP

Perform the following procedure to adjust the head gap.

1. Remove the read/write board according to Paragraph 2.4.

NOTE

Make sure the carriage assembly is riding on the top surface of the pressure pad bail (Figures 3-3 and 3-4).

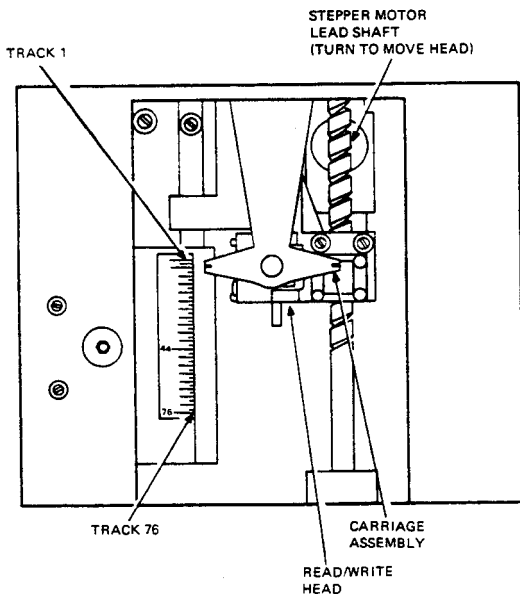

MA-6838

Figure 3-3 Head Gap Adjustment

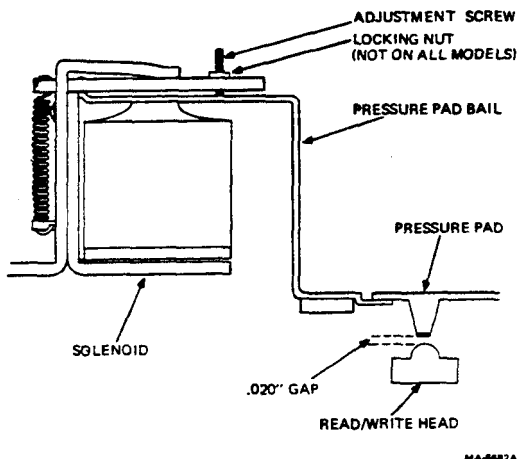

MA-9882A

Figure 3-4 RX01 Pressure Pad Mechanism
(Front View)

2. With the drive door closed, move the read/write head and carriage assembly as far away from the spindle as possible (track 1) (Figure 3-3).

NOTE

Move the head and carriage assembly by turning the stepper motor shaft.

3. With the drive door still closed, lift the pressure pad and place the plastic shim between the read/write head and felt pressure pad.

NOTE

The size of the plastic shim (P/N 93-06123-01) used for step 3 is important. Cut the yellow (0.020 in) shim to a 1 inch \times 1 inch square.

4. Refer to Figures 3-4 and 3-5. Set the RX01/RX02 on its side. If the shim stays in place, the head gap is too small. Unscrew the pressure pad adjustment screw until the shim falls out of place but drags slightly. If the shim does not drag, the head gap is too wide. Tighten the screw so that the shim drags as it falls out. On some models the gap is tightened by the locknut.

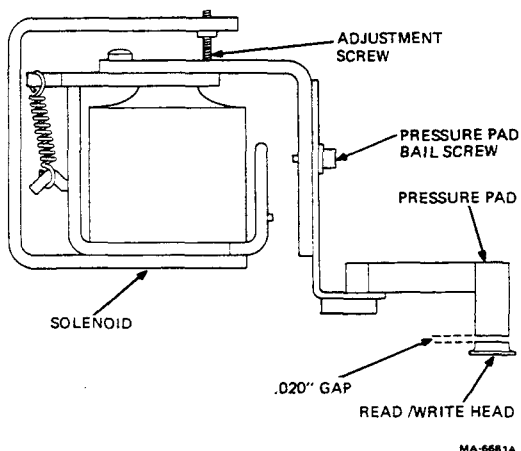

Figure 3-5 RX02 Pressure Pad Mechanism
(Front View)

- Once the gap has been adjusted, open and close the door several times.
- Close the door and recheck the gap. If it has changed, readjust the gap starting at step 2.
- Move the carriage assembly as close to the spindle as possible (track 76) and check the gap. Then, move the assembly to a midpoint, and check the gap. If the gap is correct at both points, skip step 8.
- Refer to Figure 3-5. If there is a pressure pad bail screw, loosen it. Move the bail so it is parallel to the carriage and the gap is the same at all tracks. Tighten the screw and perform step 6 again.

NOTE

If there is no pressure pad bail screw, adjustment is not possible. Replace the drive (Paragraph 2.5).

- Replace the read/write board according to Paragraph 2.4.

APPENDIX A SPARE PARTS LIST

Part	Description	DEC P/N
All Drives		
Power supply	110 V 60 Hz	H771-A
	110 V 50 Hz	H771-C
	230 V 50 Hz	H771-D
Power harness	Power supply to drive	
	90-120 V 50/60 Hz	70-10696-02
	100-132 V 50 Hz	70-10696-01
	180-240 V 50 Hz	70-10696-04
	200-264 V 50/60 Hz	70-10696-03
Fuse	2A slo blow	90-07216
Power board assembly	Regulator	70-10718-00
Plenum/fan assembly (Figure 2-6)	115 V, dual, new style	70-15622-04
	230 V, dual, new style	70-15622-05
	115 V, dual, old style	70-13503-04
	230 V, dual, old style	70-13503-05
Fan (Figure 2-6)	115 V, new style	12-15113-00
	230 V, new style	12-15742-00
	115 V, old style	12-13185-00
	230 V, old style	12-10930-01
Drive	60 Hz	70-13077-00
	50 Hz	70-13077-01
Flanged ac motor pulley	60 Hz	74-21078-00
	50 Hz	74-21078-01
Interface cable	Controller to host	BC05L-8
		BC05L-15

Part	Description	DEC P/N
All Drives		
Interface/board	Case-mounted units only	BC08R-02 54-14168
Sems screw	Hold-down for controller (Lockwasher attached)	90-09984-02
RX01 Drives Only		
Controller board		M7726
Read/write board		M7727
Resistor assembly	Must be installed in P3 connector when using M7727	70-16263-00
DIP cable	M7726 to M7727	70-08612-0F
Door handle assembly		70-14297-00
RX02 Drives Only		
Controller board		M7744
Read/write board		M7745
Ribbon cable	M7744 to M7745	70-15580-00
Door handle assembly		70-13454-00
70 Class Drives Only (70-13077)		
Drive belt	60 Hz 50 Hz	12-14005-00 12-14005-01
Spacer gauge	60 Hz 50 Hz	93-06353-02 93-06353-03

Part	Description	DEC P/N
Calcomp™ Drives Only (RX01-CA/CC)*		
Drive belt	60 Hz	12-13454-00
	50 Hz	12-13454-00
Spacer gauge	60 Hz	93-06353-00
	50 Hz	93-06353-01

™ Calcomp is a trade name of California Computer Products, Inc.

- These drives should be used when locally available to replace identical units. They cannot be ordered. Only 70 class drives can be ordered.

READER'S COMMENTS
RX01/RX02 POCKET SERVICE GUIDE
EK-RX012-PS-002

This Pocket Service Guide is intended for *Field Service Technicians*. Your comments and suggestions will help us in our continuous effort to improve its quality and usefulness.

What is your general reaction to this Pocket Service Guide?

	Excellent	Very Good	Good	Fair	Poor
Accuracy	<input type="checkbox"/>	<input type="checkbox"/>	<input type="checkbox"/>	<input type="checkbox"/>	<input type="checkbox"/>
Completeness	<input type="checkbox"/>	<input type="checkbox"/>	<input type="checkbox"/>	<input type="checkbox"/>	<input type="checkbox"/>
Organization	<input type="checkbox"/>	<input type="checkbox"/>	<input type="checkbox"/>	<input type="checkbox"/>	<input type="checkbox"/>
Format	<input type="checkbox"/>	<input type="checkbox"/>	<input type="checkbox"/>	<input type="checkbox"/>	<input type="checkbox"/>

What features are most useful?
 (Notes, Tables, Illustrations, etc.)

1. _____ 3. _____
 2. _____ 4. _____

Does the publication satisfy your needs? Yes No

What errors have you found?
 (Ref. page no., table no., and figure no.)

Comments.

Name _____

Title _____ Dept. _____

Company _____

Address _____

digital



No Postage
Necessary
if Mailed in the
United States

BUSINESS REPLY MAIL

FIRST CLASS PERMIT NO. 33 MAYNARD, MA.

POSTAGE WILL BE PAID BY ADDRESSEE

DIGITAL EQUIPMENT CORPORATION
EDUCATIONAL SERVICES DEVELOPMENT AND PUBLISHING
129 PARKER STREET, PK3-1/T12
MAYNARD, MA 01754

