

digital

RP05/RP06 disk drive
installation manual

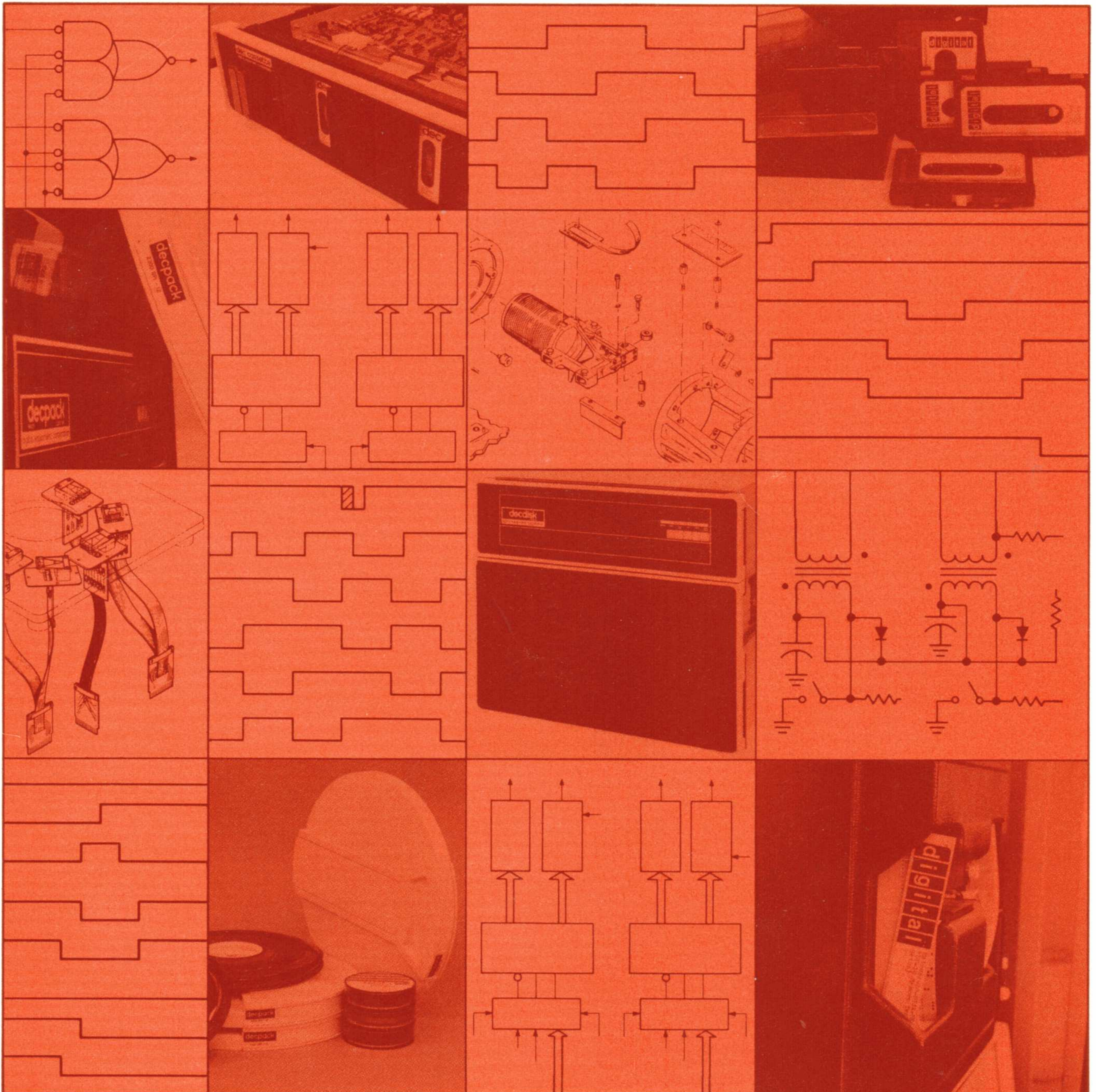

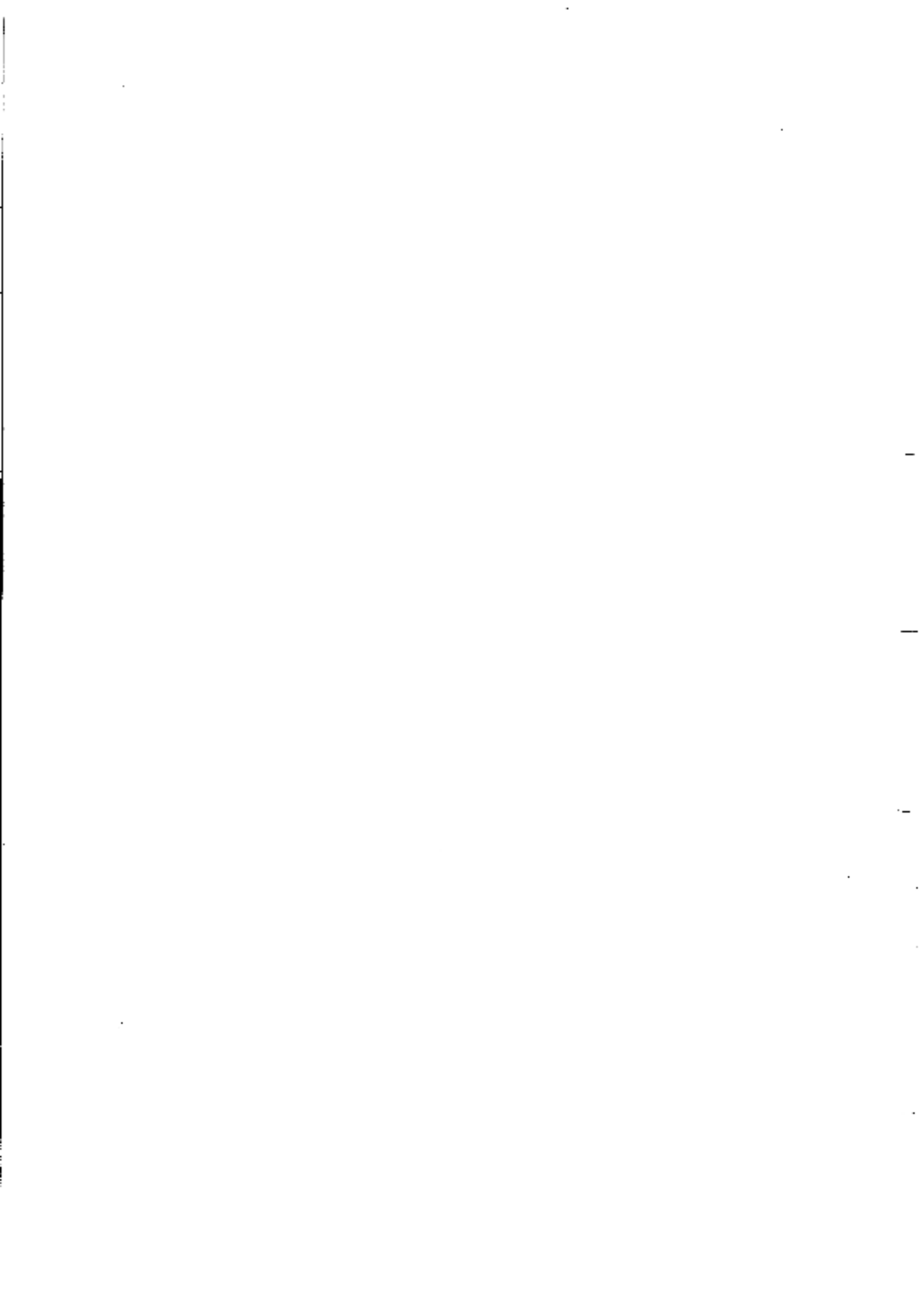

**RP05/RP06 disk drive
installation manual**

EK-RP056-IN-001

Preliminary, April 1976
1st Edition, March 1977

Copyright © 1976, 1977 by Digital Equipment Corporation

The material in this manual is for informational purposes and is subject to change without notice.

Digital Equipment Corporation assumes no responsibility for any errors which may appear in this manual.

Printed in U.S.A.

This document was set on DIGITAL's DECset-8000 computerized typesetting system.

DISCLAIMER

Removable media involve use, handling and maintenance which are beyond DEC's direct control. DEC disclaims responsibility for performance of the Equipment when operated with media not meeting DEC specifications or with media not maintained in accordance with procedures approved by DEC. DEC shall not be liable for damages to the Equipment or to media resulting from such operation.

The following are trademarks of Digital Equipment Corporation, Maynard, Massachusetts:

DEC	DECtape	PDP
DECCOMM	DECUS	RSTS
DECsystem-10	DIGITAL	TYPESET-8
DECSYSTEM-20	MASSBUS	TYPESET-11
		UNIBUS

CONTENTS

		Page
CHAPTER 1	GENERAL INFORMATION	
1.1	INTRODUCTION	1-1
1.2	MANUAL PURPOSE AND ORGANIZATION	1-2
1.2.1	Chapter Contents	1-2
1.2.2	Related Documentation	1-3
1.2.3	Option Designations	1-3
1.3	RP05/RP06 DISK DRIVE SPECIFICATIONS	1-3
1.3.1	Features	1-3
1.3.2	Mechanical Specifications	1-4
1.3.3	Electrical Specifications	1-4
1.3.4	Access Times	1-5
1.3.5	Operation	1-6
1.3.6	Disk Pack	1-6
CHAPTER 2	SITE PREPARATION	
2.1	SPACE	2-1
2.2	CABLING	2-2
2.2.1	RH11/RH70 Systems	2-2
2.2.2	RH10/RH20 Systems	2-2
2.3	POWER REQUIREMENTS	2-3
2.4	FLOOR LOADING	2-4
2.5	INSTALLATION CONSTRAINTS	2-4
2.6	FIRE AND SAFETY PRECAUTIONS	2-4
CHAPTER 3	ENVIRONMENTAL CONSIDERATIONS	
3.1	GENERAL	3-1
3.2	TEMPERATURE	3-1
3.3	RELATIVE HUMIDITY	3-1
3.4	HEAT DISSIPATION	3-1
3.5	ACOUSTICS	3-1
3.6	ALTITUDE	3-1
3.7	RADIATED EMISSIONS	3-2
3.8	AIR CIRCULATION	3-2
3.9	CLEANLINESS	3-2
CHAPTER 4	INSTALLATION	
4.1	UNPACKING AND INSPECTION	4-1
4.2	INSTALLING THE RP05/RP06	4-12
4.2.1	Safety Precautions	4-12
4.2.2	Installation Procedure	4-12
4.3	INSTALLATION CHECKS AND ADJUSTMENTS	4-17
4.3.1	DCL Unit Power Supply Voltage Checks	4-17
4.3.1.1	Regulator Board Module A1	4-17
4.3.1.2	Regulator Board Module A2	4-17

CONTENTS (CONT)

	Page	
4.3.2	Drive Power Supply Voltage Check	4-19
4.3.2.1	AC Power Checks	4-19
4.3.2.2	DC Power Checks	4-19
4.3.3	Readiness Tests	4-19
4.3.4	Drive Cycle Up/Down Checks	4-20
4.3.5	Response to Abnormal Conditions	4-21
4.3.5.1	Clearing an Unsafe Condition	4-21
4.3.5.2	Removing a Pack With No Drive Power	4-21
4.3.5.3	Detecting Head-to-Disk Interference	4-22
4.4	TESTER HOOKUP, ROUTINES, AND RUN OPTIONS	4-22
4.4.1	Tester Hookup	4-22
4.5	HEAD CLEANING	4-29
4.5.1	Head Inspection Procedure	4-29
4.5.2	Possible Head Conditions	4-30
4.5.2.1	Clean Head	4-30
4.5.2.2	Dirty Head	4-30
4.5.2.3	Head/Disk Interference	4-30
4.5.3	Head Cleaning	4-30
4.6	POWER	4-31
4.6.1	Power Conversion	4-31
4.6.1.1	50-Hz to 60-Hz Conversion	4-31
4.6.1.2	60-Hz to 50-Hz Conversion	4-32
4.6.2	Power Configuration Check	4-32
4.6.2.1	60-Hz Drive	4-32
4.6.2.2	50-Hz Drive	4-34
CHAPTER 5	INSTALLING THE RP05/RP06 INTO AN RJP05/RJP06 SUBSYSTEM	
5.1	INTRODUCTION	5-1
5.2	ELECTRICAL	5-1
5.2.1	Power Cable Connections	5-1
5.2.2	Unibus Cable Connections	5-3
5.2.2.1	Unibus A Connections	5-3
5.2.2.2	Unibus B Connections	5-3
5.2.3	Massbus Cable Connections	5-5
5.2.4	AC LO, DC LO	5-6
5.3	JUMPER CONFIGURATIONS	5-10
5.3.1	BCT Module (M7295)	5-10
5.3.1.1	Register Selection	5-10
5.3.1.2	BR Level Interrupt	5-10
5.3.1.3	NPR Latency	5-10
5.3.1.4	Bus Grant	5-10
5.3.1.5	Vector Address Jumpers	5-11
5.3.1.6	MXF Jumper	5-11
5.3.2	DBC Module (M7294)	5-11

CONTENTS (CONT)

		Page
5.3.2.1	NPR Cycle Selection Jumpers	5-11
5.3.2.2	Unibus Parity Jumpers	5-11
5.3.2.3	Start Counter Jumpers	5-11
5.3.3	CSR Module (M7296)	5-12
5.4	RH11 INSTALLATION PROCEDURE	5-12
CHAPTER 6	RJP05/RJP06 FIELD ACCEPTANCE PROCEDURES AND DIAGNOSTICS	
6.1	INTRODUCTION	6-1
6.2	ERROR DEFINITIONS/RATES	6-1
6.2.1	Hard Errors	6-1
6.2.2	Soft Errors	6-3
6.2.3	Pack-Attributable Errors	6-3
6.2.4	Seek Errors	6-3
6.3	RJP05/RJP06 FIELD ACCEPTANCE TEST	6-3
6.3.1	Operational Checks, Single Controller	6-3
6.3.2	Operational Checks, Dual Controller	6-6
6.4	DIAGNOSTIC MAINTENANCE	6-8
6.4.1	MAINDEC-11-DZRJG and MAINDEC-11-DZRJH – RP04/05/06 Diskless Controller Test	6-8
6.4.2	MAINDEC-11-DZRJI and MAINDEC-11-DZRJJ – RP04/05/06 Functional Controller Test	6-9
6.4.3	MAINDEC-11-DZRJE and MAINDEC-11-DZRJF RP04/05/06 Dual-Controller Logic Test (Parts 1 and 2)	6-9
6.4.4	MAINDEC-11-DZRJA – RP04/05/06 Mechanical and Read/Write Test	6-9
6.4.5	MAINDEC-11-DZRJD – RP04/05/06 Multidrive Exerciser	6-9
6.4.6	MAINDEC-11-DZRJB – RP04/05/06 Formatter Program	6-10
6.4.7	MAINDEC-11-DZRJC – RP04/05/06 Head Alignment Verification Program	6-10
CHAPTER 7	INSTALLING THE RP05/RP06 INTO AN RHP05/RHP06 SUBSYSTEM	
7.1	INTRODUCTION	7-1
7.2	ELECTRICAL	7-1
7.2.1	Power Cable Connections	7-3
7.2.2	Massbus Cable Connections	7-4
7.3	RH10 MAINTENANCE PANEL	7-4
7.4	VISUAL INSPECTION	7-6
CHAPTER 8	RHP05/RHP06 FIELD ACCEPTANCE PROCEDURES AND DIAGNOSTICS	
8.1	INTRODUCTION	8-1
8.2	ERROR DEFINITIONS/RATES	8-1
8.2.1	Soft Errors	8-1
8.2.2	Hard Errors	8-1
8.2.3	Seek Errors	8-1

CONTENTS (CONT)

	Page
8.2.4	Pack-Attributable Errors 8-1
8.2.5	Read Errors 8-1
8.3	RIP05/RIP06 ACCEPTANCE TESTING 8-2
8.4	DIAGNOSTIC DESCRIPTIONS 8-2
CHAPTER 9	INSTALLING THE RP05/RP06 INTO AN RTP05/RTP06 SUBSYSTEM
9.1	INTRODUCTION 9-1
9.2	ELECTRICAL 9-1
9.2.1	Power Cable Connections 9-1
9.2.1.1	RII20 9-1
9.2.1.2	RP05/RP06 9-2
9.2.2	Massbus Cable Connections 9-2
CHAPTER 10	RTP05/RTP06 FIELD ACCEPTANCE PROCEDURES AND DIAGNOSTICS
10.1	INTRODUCTION 10-1
10.2	ERROR DEFINITIONS/RATES 10-1
10.2.1	Soft Errors 10-1
10.2.2	Hard Errors 10-1
10.2.3	Seek Errors 10-1
10.2.4	Pack-Attributable Errors 10-1
10.2.5	Read Errors 10-1
10.3	RTP05/RTP06 ACCEPTANCE TESTING 10-2
10.4	DIAGNOSTIC DESCRIPTIONS 10-2
CHAPTER 11	INSTALLING THE RP05/RP06 INTO AN RWP05/RWP06 SUBSYSTEM
11.1	INTRODUCTION 11-1
11.2	ELECTRICAL 11-1
11.2.1	Power Cable Connections 11-1
11.2.2	Module Locations 11-1
11.2.3	Massbus Cable Connections 11-1
11.3	JUMPER CONFIGURATIONS 11-1
11.3.1	BCF Module (M8153) 11-4
11.3.1.1	Register Selection 11-4
11.3.1.2	BR Level Interrupt 11-4
11.3.1.3	Vector Address Jumpers 11-5
11.3.2	MDP Module (M8150) 11-5
11.4	LIGHT-EMITTING DIODES (LEDs) 11-5

CONTENTS (CONT)

	Page
CHAPTER 12	RWP05/RWP06 FIELD ACCEPTANCE PROCEDURES AND DIAGNOSTICS
12.1	INTRODUCTION 12-1
12.2	ERROR DEFINITIONS/RATES 12-1
12.2.1	Hard Errors 12-1
12.2.2	Soft Errors 12-1
12.2.3	Pack-Attributable Errors 12-1
12.2.4	Seek Errors 12-3
12.3	RWP05/RWP06 FIELD ACCEPTANCE TEST 12-3
12.4	DIAGNOSTIC MAINTENANCE 12-3
12.4.1	MAINDEC-11-DERHA - RH70 Controller Test 12-4
12.4.2	MAINDEC-11-DZRIG, MAINDEC-11-DZRJH - RP04/RP05/RP06 Diskless Controller Test 12-4
12.4.3	MAINDEC-11-DZRJI, MAINDEC-11-DZRJJ - RP04/RP05/RP06 Functional Controller Test 12-4
12.4.4	MAINDEC-11-DZRJA - Mechanical Read/Write Test 12-4
12.4.5	MAINDEC-11-DZRJE, MAINDEC-11-DZRJF - Dual-Port Logic Test (Parts 1 and 2) 12-4
12.4.6	MAINDEC-11-DZRJD - Multidrive Exerciser 12-5
12.4.7	MAINDEC-11-DZRJE - Formatter Program 12-5
12.4.8	MAINDEC-11-DZRJC - Head Alignment Verification Program 12-6
CHAPTER 13	OPTIONS
13.1	INTRODUCTION 13-1
13.2	DUAL-PORT OPERATION 13-1
13.2.1	Converting to Dual-Port 13-1
13.2.2	Conversion Procedure 13-1
13.3	UPGRADING THE RP05 TO AN RP06 13-11
13.3.1	Introduction 13-11
13.3.2	Mechanical Conversion 13-11
13.3.3	Head Conversion 13-12
13.3.4	Electrical Conversion 13-13
13.3.5	Test Procedure 13-13

FIGURES

Figure No.	Title	Page
1-1	Drive and DCL Assemblies	1-1
2-1	RP05/RP06 Service Clearances (Front)	2-1
2-2	RP05/RP06 Service Clearances (Rear)	2-2
2-3	Special 76-cm (30-in) RC06S Cable Configuration for Drive End	2-3
3-1	Air Flow and Filtration System	3-3
3-2	Disk Pack Relationship of Disk Head, Disk, Contaminants	3-4
4-1	Special Tools for RP05/RP06 Installation	4-3
4-2	Door Lock Override Mechanism	4-6
4-3	Location of Nameplate and Serial Number Tag	4-7
4-4	T-Block Viewed from Linear Motor	4-8
4-5	DCL/Drive Signal Interface Connections	4-8
4-6	Shipping Brackets	4-9
4-7	Absolute Filter and Pack Loading Rod	4-10
4-8	Shipping Spacers and Support Bar	4-11
4-9	RP05/RP06 Installation	4-13
4-10	RP05/RP06 Connector Panel	4-14
4-11	Massbus Connector Prior to Mounting	4-15
4-12	Massbus Connector Mounted	4-16
4-13	Power Distribution (DCL Unit)	4-18
4-14	RP05/RP06 800 Disk Storage Subsystem Tester	4-23
4-15	Tester Cable Hook-Up	4-24
4-16	Cleaning Heads in Drive	4-31
4-17	Transformer Primary and Secondary Connections	4-33
5-1	RH11 Module Utilization	5-2
5-2	Single-Port Unibus Configuration	5-4
5-3	Dual-Port Configuration — Memory on Unibus B	5-4
5-4	Dual-Port Configuration Memory and Processor on Unibus B	5-5
5-5	Massbus Cable System Configuration	5-6
5-6	Typical Power Fail Configuration for RH11 and Options Mounted in Same Expander Box	5-7
5-7	Typical Power Fail Configuration for Two RH11s Mounted in Same Expander Box	5-8
5-8	Typical Power Fail Configuration for RH11 and CPU Mounted in Processor Box	5-9
7-1	RP05/RP06 Register Format (RH10)	7-2
7-2	RH10/DF10/RP04/RP05/RP06 Interconnection Diagram	7-3
9-1	RH20/DF10/RP04/RP05/RP06 Interconnection Diagram	9-2
11-1	Module Utilization Chart	11-2
11-2	Massbus Cable System Configuration	11-3
11-3	LED Physical Locations	11-6
13-1	Drive and DCL Assemblies Rear View, Rear Panels Removed	13-2
13-2	Card Nest in Horizontal Position	13-3
13-3	DCL Rear View, Card Nest and Cable Assembly Extended	13-4
13-4	Card Nest and Cable Assembly PCB Layout	13-5

FIGURES (CONT)

Figure No.	Title	Page
13-5	Connecting Module C (M5903)	13-7
13-6	Connecting Module B (M5903)	13-8
13-7	Connecting Module A (M5903)	13-9
13-8	Module Locations of M5903S	13-10

TABLES

Table No.	Title	Page
4-1	Tools Required for RP05/RP06 Installation	4-2
4-2	DC Voltages	4-19
4-3	Tester Routine Numbers and Run Options	4-25
4-4	Function Switch Operations	4-28
4-5	Hexadecimal-Octal Conversion	4-29
6-1	RP05/RP06 Error Conditions	6-2
6-2	Format (MAINDEC-11-DZRJB) Run Procedure	6-5
12-1	RP05/RP06 Error Conditions	12-2

CHAPTER 1 GENERAL INFORMATION

1.1 INTRODUCTION

The RP05/RP06 Disk Drive (Figure 1-1) is a high-performance, direct-access, single-head-per-surface drive designed to enable a data-processing system to store and retrieve blocks of data at any location on a rotating disk. The RP05/RP06 consists of a 677-51 (RP05) or 677-01 (RP06) disk drive, which is manufactured by Memorex, and a device control logic (DCL) unit, which is manufactured by Digital Equipment Corporation. The DCL unit contains the control electronics required to supervise the RP05/RP06 operations.

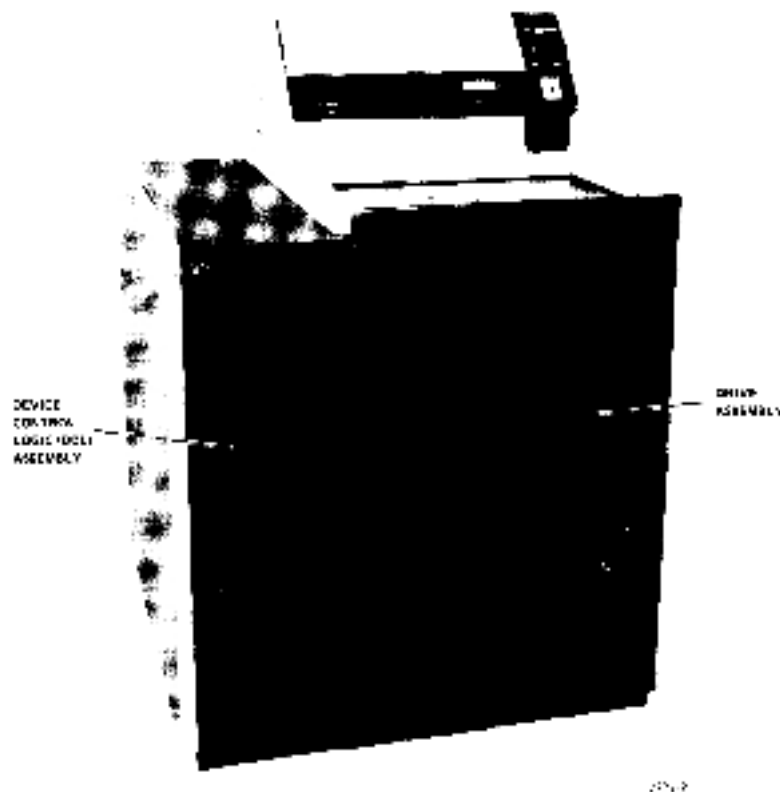

Figure 1-1 Drive and DCL Assemblies

The optional dual-access logic package may be accessed by either or both of the central processing units (CPUs) on a time-sharing basis. A switch on the control panel of the drive permits the control logic to select either or both CPUs.

NOTE

The primary functional difference between an RP05 and an RP06 Disk Drive is in their storage capacities. An RP05 can address up to 411 cylinders; an RP06 can address up to 815 cylinders. Except for this difference, the RP05 and RP06 are quite similar in their functions and interfaces. In this manual, when descriptions are applicable to both the RP05 and the RP06, they will be referred to either as the RP05/RP06 Disk Drive, or simply as disk drives. Where descriptions differ for the two drives, those differences will be noted and the individual drives will be referred to as the RP05 or RP06 Disk Drive.

1.2 MANUAL PURPOSE AND ORGANIZATION

This manual provides information on installing the RP05/RP06 Disk Drive into a computer system. To accomplish this purpose, the manual is organized in 13 chapters and is supported by the related documents listed in Paragraph 1.2.2.

1.2.1 Chapter Contents

Chapter 1 contains the general information necessary to introduce the RP05/RP06 and to present its characteristics and specifications.

Chapter 2 discusses the planning required to make the installation site compatible with operation of the RP05/RP06, with particular attention to such considerations as space, cabling, power, floor loading, and fire and safety precautions.

Chapter 3 covers the specific environmental characteristics of the RP05/RP06 with respect to temperature, relative humidity, air-conditioning and/or heat dissipation, acoustics, and cleanliness.

Chapter 4 describes the actual step-by-step process of installing the unit, from unpacking through preliminary checks and power verification.

Chapter 5 describes how to install the RP05/RP06 Disk Drive as a part of the RJP05/RJP06 subsystem. Chapter 6 lists the field acceptance procedures and diagnostics appropriate to such an installation.

Chapter 7 describes how to install the RP05/RP06 Disk Drive as a part of the RHP05/RHP06 subsystem. Chapter 8 lists the field acceptance procedures and diagnostics appropriate to such an installation.

Chapter 9 describes how to install the RP05/RP06 Disk Drive as a part of the RTP05/RTP06 subsystem. Chapter 10 lists the field acceptance procedures and diagnostics appropriate to such an installation.

Chapter 11 describes how to install the RP05/RP06 Disk Drive as a part of the RWP05/RWP06 subsystem. Chapter 12 lists the field acceptance procedures and diagnostics appropriate to such an installation.

Chapter 13 deals with the optional dual-port configuration and discusses the potential upgrading of RP05/RP06 operation.

1.2.2 Related Documentation

This manual and the following documents comprise a complete documentation package for the RP05/RP06 Disk Drive. When the drive is used with the PDP-11, applicable documents include:

- RJP05/RJP06 Moving Head Disk Subsystem Maintenance Manual (EK-RJP05-MM-001)
- RWP05/RWP06 Moving Head Disk Subsystem Maintenance Manual (EK-RWP56-MM-001)
- RP05/RP06 Device Control Logic Maintenance Manual (EK-RP056-MM-001)
- RP05/RP06 DCI. Print Set (MP0086).

Manuals related to the disk drive include:

- Memorex RP05/RP06 677-01/S1 DEC Disk Storage Drives Technical Manual (ER-00012)
- Memorex RP05/RP06 677-01/677-51 Disk Storage Drive Illustrated Parts Catalog (ER-00011)
- Memorex RP05/RP06 677-01 Logic Manual (EK-RP05M-TM-V02).

1.2.3 Option Designations

The single-access version of the RP05/RP06 Disk Drive is designated as the RP05/RP06-AA (60 Hz) or RP05/RP06-AB (50 Hz); the dual-access version is designated as the RP05/RP06-BA (60 Hz) or RP05/RP06-BB (50 Hz).

The disk pack used with RP05 Disk Drive, which is an IBM 3336 type, is designated as the RP04P Disk Pack. The disk pack used with the RP06 Disk Drive, which is an IBM 3336-11 type, is designated as the RP06P Disk Pack.

WARNING

The disk packs used on the RP05 and those used on the RP06 are NOT interchangeable. Attempts to force the wrong pack onto a drive can damage the pack or the drive, or both, and can lead to subsequent damage to other packs or drives.

1.3 RP05/RP06 DISK DRIVE SPECIFICATIONS

The RP05/RP06 Disk Drive is a high-performance, direct-access, single-head-per-surface drive that enables a data processing system to store or retrieve information at any location on a rotating disk pack.

1.3.1 Features

The RP05/RP06 features error detection and correction capability hardware that is permanently installed. Two sector formats are available:

- 20 sectors per data track (256 18-bit words per data field of each sector)
 - 2.79 μ s (burst rate)
 - 3.25 μ s (average rate for multiple sector transfers)
- 22 sectors per data track (256 16-bit words per data field of each sector)
 - 2.48 μ s (burst rate)
 - 2.96 μ s (average rate for multiple sector transfers).

The RP05/RP06 also offers remote standby operation and optional dual-controller capability.

1.3.2 Mechanical Specifications

Mounting Mounted in a free-standing cabinet, approximately 119 cm h × 84 cm w × 81 cm d (47 in h × 33 in w × 32 in d). The width includes a 25.4-cm (10-in) chassis attached to the side of the basic cabinet.

Weight 273 kg (600 lb)

1.3.3 Electrical Specifications

Standard Power Requirements

DC None

AC 208 Vac ± 10%, DELTA, 60 Hz ± 1%, 3-phase
380 Vac ± 10%, Star W/Neutral, 50 Hz ± 1%, 3-phase

Other Power Options 230 Vac ± 10%, DELTA, 60 Hz ± 1%, 3-phase
240 Vac ± 10%, DELTA, 50 Hz ± 1%, 3-phase
408 Vac ± 10%, Star W/Neutral, 50 Hz ± 1%, 3-phase
420 Vac ± 10%, Star W/Neutral, 50 Hz ± 1%, 3-phase
220 Vac ± 10%, DELTA, 50 Hz ± 1%, 3-phase
230 Vac ± 10%, DELTA, 50 Hz ± 1%, 3-phase

Surge (starting) current does not exceed five times running current which shall not exceed 6 A per phase (excluding DCL). Maximum phase current unbalance on two drives (excluding DCL) shall not exceed 70 percent. A maximum of two 60 Hz drives may be connected on any one 60 Hz ac cable string. Only one 50 Hz drive may be connected on any one 50 Hz cable string.

Non-Operating Temperature Range 10° C minimum, 43° C maximum
(50° F minimum, 110° F maximum)

Drive Cooling (Internal) Forced air

Maximum Wet Bulb Temperature 26° C (78° F)

Heat Dissipation 2100 W (7000 Btu/hr) maximum
1650 W (5500 Btu/hr) nominal

Relative Humidity 20% minimum, 80% maximum (no condensation)

Vibration 1.3 g from 2 to 5 Hz

Shock

Operating	3 g for 10 ms, 3 pulses in vertical direction only
Shipping	6 g for 30 ms, 3 pulses in vertical direction only

Read/Write

Number of Read/Write Heads	19 (plus 1 read head for the servo)
Cylinders Per Disk Pack	411 on an RP05 pack 815 on an RP06 pack
Tracks Per Cylinder	19
Total Number of Tracks	7,809 per RP05 disk pack 15,485 per RP06 disk pack
Data Bits Per Track, Maximum	107,520 (unformatted)
Data Bits Per Cylinder, Maximum	2,042,880 (unformatted)
Data Bits Per Disk Pack, Maximum	840,000,000 (unformatted) on an RP05 pack 1,665,000,000 (unformatted) on an RP06 pack
Data Rate (Nominal)	6,448,000 bits/second
Data Words Per Disk Pack (Formatted Capacity)	43,980,288 (22-sector pack, 16-bit words) on an RP05 pack 39,982,080 (20-sector pack, 18-bit words) on an RP05 pack 87,211,520 (22-sector pack, 16-bit words) on an RP06 pack 79,283,200 (20-sector pack, 18-bit words) on an RP06 pack
Data Compatibility	The drive allows for disk pack interchangeability between PDP-10/PDP-11/PDP-15 system through software-controlled format and data word width settings.

NOTE

RP05 and RP06 disk packs are not interchangeable.

1.3.4 Access Times

One Cylinder Seek	6 ms
Average Seek	28.5 ms
Maximum Seek	53 ms
Average Rotational Latency Time	8.33 ms

1.3.5 Operation

Start-Up Time (Head Load and First Seek)	15 seconds
Disk Rotational Speed	3600 rev/min \pm 2.5% (counterclockwise)
Stop Time (Retract Heads and Stop Disk Rotation)	15 seconds
Disk Drive Motor	1 hp induction, 208/230 Vac, single-phase
Bit-Cell Time	155 ns

1.3.6 Disk Pack

Type	RP04P pack (IBM 3336 type) for an RP05 RP06P pack (IBM 3336-11 type) for an RP06
Disk Diameter	35.56 cm (14 in)
Number of Disks	10 magnetic disks (not including upper and lower protective disks)
Magnetic Recording Surfaces	19 (uppermost surface is numbered zero)

CHAPTER 2 SITE PREPARATION

2.1 SPACE

Provision should be made for service clearances of 71 cm (28 in) at the front and rear of the RP05/RP06 Disk Drive, and 51 cm (20 in) at either side of a drive string (Figures 2-1 and 2-2). Space should also be made available in the system environment for storage of disk packs, each of which has a diameter of approximately 36 cm (14 in) when covered, and a height of approximately 18 cm (7 in) to the handle of the top assembly. Disk packs should never be stacked on top of one another; a designated shelf area is recommended for each pack.

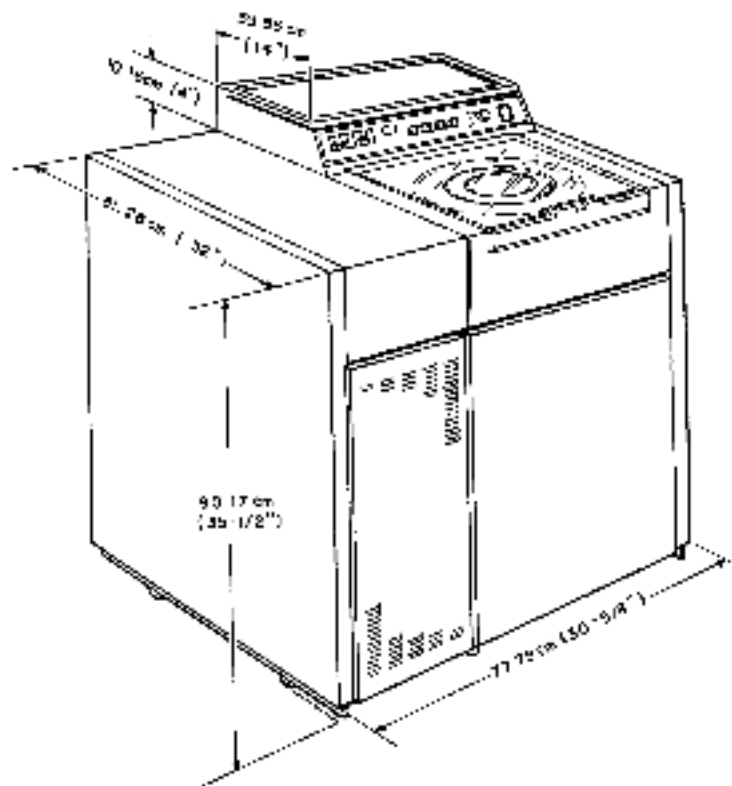

CP-1554

Figure 2-1 RP05/RP06 Service Clearances (Front)

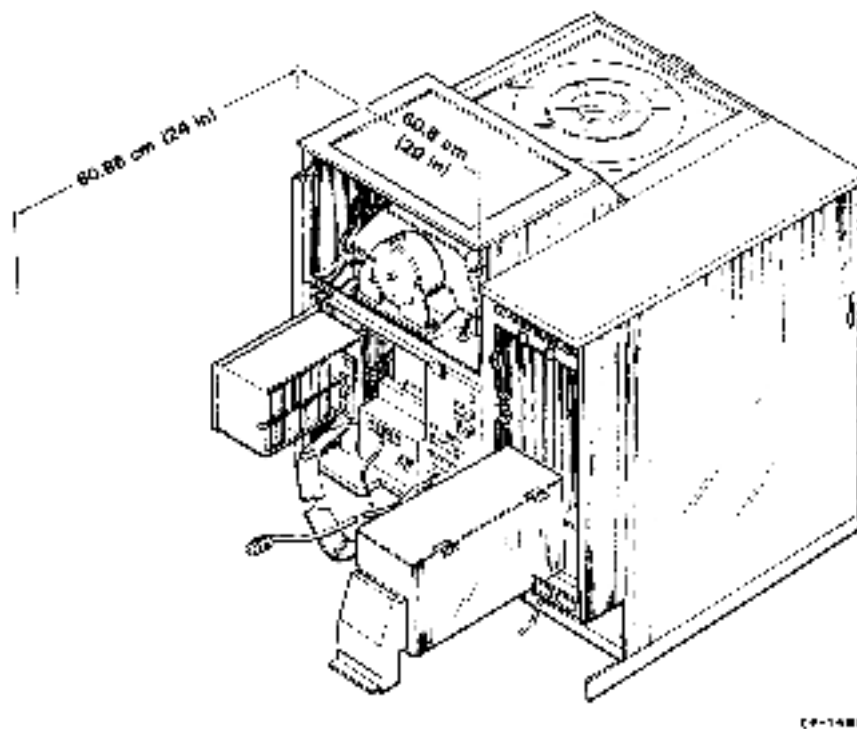

Figure 2-2 RP05/RP06 Service Clearances (Rear)

2.2 CABLING

No more than two 60 Hz RP05/RP06 Disk Drives and only one 50 Hz RP05/RP06 Disk Drive should be supplied from one ac power source. (Refer to Paragraph 4.2.2, step 5.) The ac power cable used to connect the drive to the facility power source must not exceed 4.6 m (15 ft) in length.

The maximum Massbus interface cable length available (round cable) is 12.2 m (40 ft); thus, the first drive must be mounted no more than that distance from the controller. Multiple drives installed in the *string* configuration (side-by-side) will be connected by a standard 76-cm (30-in) cable provided with each RP05/RP06. Figure 2-3 shows a modified RC06S cable (70-12066) configuration for drive-end RP05/RP06 use.

An optional 3-m (10-ft) cable can be provided for those situations where the string configuration cannot be utilized.

2.2.1 RH11/RH70 Systems

The aggregate length of all round cables in an RH11/RH70 system, regardless of the configuration selected, must not exceed 18.3 m (60 ft) per controller.

2.2.2 RH10/RH20 Systems

The aggregate length of all round cables in an RH10/RH20 system, regardless of the configuration selected, must not exceed 48.8 m (160 ft) minus 3.8 m (12.5 ft) for each RP05/RP06 on the system.

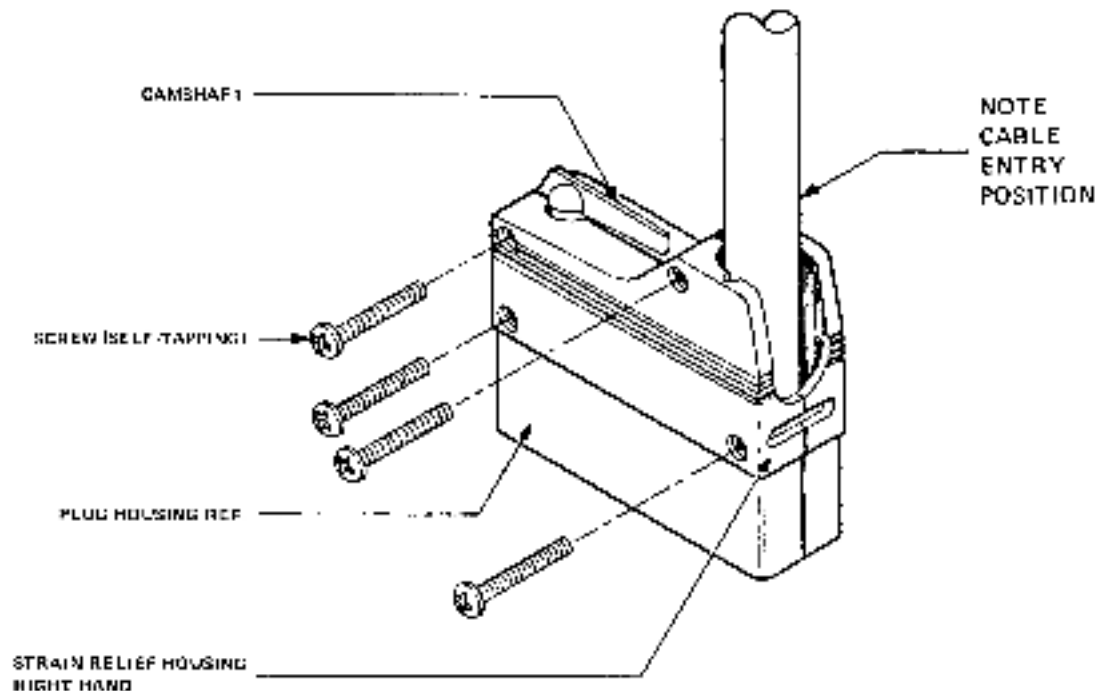

OF 2/90

Figure 2-3 Special 76-cm (30-in) BC06S Cable Configuration for Drive End

2.3 POWER REQUIREMENTS

Standard power requirements (ac) for RP05/RP06 Disk Drives are:

- 208 Vac \pm 10%, DELTA, 60 Hz \pm 1%, 3-phase
- 380 Vac \pm 10%, Star W/Neutral, 50 Hz \pm 1%, 3-phase.

Other power options include the following:

- 230 Vac \pm 10%, DELTA, 60 Hz \pm 1%, 3-phase
- 240 Vac \pm 10%, DELTA, 50 Hz \pm 1%, 3-phase
- 408 Vac \pm 10%, Star W/Neutral, 50 Hz \pm 1%, 3-phase
- 420 Vac \pm 10%, Star W/Neutral, 50 Hz \pm 1%, 3-phase
- 220 Vac \pm 10%, DELTA, 50 Hz \pm 1%, 3-phase
- 230 Vac \pm 10%, DELTA, 50 Hz \pm 1%, 3-phase.

Surge (starting) current does not exceed five times the running current, which should not exceed 6 A per phase, excluding DCL. The maximum phase current unbalance on two drives (excluding DCL) should not exceed 70 percent.

Receptacles that will accept the 120 V/208 V, 60-Hz plugs are designated variously by DEC (12-11210), NEMA (1.21-20R), Hubbell (2510), and Bryant (72120-FR). Receptacles that will accept 240/416 V, 50-Hz plugs bear a DEC designation (12-11259) but no NEMA or manufacturers' numbers are presently available.

It is also necessary to have 20 A circuit breakers.

Digital Equipment Corporation should be notified *well in advance of shipment* regarding the input power requirements so that the kits necessary for conversion to available facility power can be available at the time of installation.

2.4 FLOOR LOADING

The weight of the RP05/RP06 Disk Drive (272 kg/600 lb) alone is not sufficient to place unusual stress on most office building or industrial plant floors. However, the added weight should be considered in relation to the weight of the existing computer system and possible future expansion.

2.5 INSTALLATION CONSTRAINTS

The route the equipment will travel from the receiving area to the installation site should be studied in advance to ensure problem-free delivery. Among the factors to be taken into consideration are the height and location of loading doors; the size, capacity, and availability of elevators; the number and size of the aisles and doors en route; and any restrictions, such as bends or obstructions, in the hallways. Any constraints should be reported to Digital Equipment Corporation as soon as possible so that the requirements of the individual installation site may be considered when the unit is packed for shipment. The width of the RP05/RP06, 83.19 cm (32-3/4 in), can be reduced to 79.8 cm (31-3/8 in) by removing the side panels.

False flooring should not be necessary if the drives in the system are to be installed side-by-side in the string configuration, as the 76-cm (30-in) cables provided with the units are just long enough to be run inside the drive cabinets to connect the units. However, if geographical or other considerations necessitate some other configuration, or if the first RP05/RP06 in the string configuration is not adjacent to the controller, false flooring may be required to avoid exposed cables. It may be necessary to remove end panels.

2.6 FIRE AND SAFETY PRECAUTIONS

The RP05/RP06 Disk Drive presents no unusual additional fire or safety hazards to an existing computer system. Wiring should be carefully checked, however, to ensure that the capacity is adequate for the added load and for any contemplated expansion.

CHAPTER 3

ENVIRONMENTAL CONSIDERATIONS

3.1 GENERAL

The RP05/RP06 Disk Drive is capable of efficient operation even in marginal environments. The parameters of the operating environment are determined by the most restrictive facets of the system.

3.2 TEMPERATURE

The operating temperature range of the RP05/RP06 is from 16° C to 32° C (60° F to 90° F), with a maximum gradient of 2.8° C (5° F) per hour. The nonoperating temperature range is from 10° C to 44° C (50° F to 110° F), with a maximum gradient of 5.6° C (10° F) per hour. The shipping temperature range is from -45.6° C to 60° C (-50° F to 140° F), with a maximum gradient of 8.4° C (15° F) per hour.

3.3 RELATIVE HUMIDITY

Humidity control is important in any system, as static electricity can cause errors in any CPU with memory. The RP05/RP06 is designed to operate efficiently within a relative humidity range of 20 percent to 80 percent, with a maximum wet bulb temperature of 26° C (78° F) and a minimum dew point of 2° C (36° F). The nonoperating relative humidity range is from 8 percent to 85 percent, with no condensation. The shipping relative humidity range is from 5 percent to 90 percent, with no condensation.

3.4 HEAT DISSIPATION

Heat dissipation for the RP05/RP06 Disk Drive is 5500 Btu/hour, nominal and 7000 Btu/hour, maximum. By adding this figure to the total heat dissipation for the other system components, and then adjusting the result to compensate for such factors as the number of personnel, heat radiation from adjoining areas, sun exposure through windows, system efficiency, etc., the approximate cooling requirements for the system can be determined. It is advisable to allow a safety margin of at least 25 percent above the maximum estimated requirements.

3.5 ACOUSTICS

Most computer sites require at least some degree of acoustic treatment; however, the RP05/RP06 Disk Drive should not contribute unduly to the overall acoustic problem. Acoustic materials should neither produce nor harbor dust.

3.6 ALTITUDE

Computer system operation at high altitudes can result in heat dissipation problems. The maximum altitude specified for the RP05/RP06 is 1980 m (6500 ft). If operation at high altitudes is anticipated, DEC should be notified when the equipment is ordered.

3.7 RADIATED EMISSIONS

Sources of radiation such as FM, vehicle ignitions, and radar transmitters located in close proximity to the computer system may affect the performance of the RP05/RP06 Disk Drive because of the possible adverse effect magnetic fields can have on disk packs. A magnetic field with an intensity of 50 oersteds might destroy all of the information on an individual disk pack.

The effects of radiated emissions can be reduced by:

1. Grounding window screens and other large metal surfaces
2. Shielding interconnection cables with grounded shields
3. Verifying existing grounds for common-mode currents
4. In extreme radiation environments, providing a grounded cage for the system.

3.8 AIR CIRCULATION

The air circulation system of the RP05/RP06 Disk Drive (Figure 3-1) is designed to supply clean air for:

- Disk temperature control
- Pressurization of the shroud area
- Logic cage cooling.

To ensure that intake air moves freely into the drive, floor access must not be restricted by cables, etc.

3.9 CLEANLINESS

Although cleanliness is important in all facets of a computer system, it is particularly crucial to the RP05/RP06 Disk Drive. Disk packs are not sealed units and are extremely vulnerable to dirt. Even such minute obstructions as smoke particles, fingerprint smudges, or dust specks can cause head crashes and catastrophic destruction of heads and/or disk surfaces, as illustrated in Figure 3-2.

During site preparation, there are a number of steps that may be taken to enhance cleanliness.

- Seal all windows in the vicinity of the RP05/RP06 locations.
- If partitions are to be installed, consider floor-to-ceiling walls, which minimize the flow of dust.
- Check that the flow of air from the air-conditioning system will tend to carry lint, etc., away from the RP05/RP06 location. Provide filtration to inhibit dust and other particulate matter.
- If painting is to be done in advance of installation, select paint for walls, ceilings, and floors that will not tend to flake or powder excessively. (Waterbound distemper is generally unsatisfactory in this respect.)
- Select acoustic material that will neither produce nor harbor dust.
- Avoid glass fiber tiles that could produce abrasive particles, and floor coverings that tend to crack or crumble.
- Provide closed cabinets for disk storage.
- Clean and vacuum subfloor areas and air-conditioning systems just before installation.
- Place impregnated mats at each entrance to reduce the amount of dust tracked in from other areas.

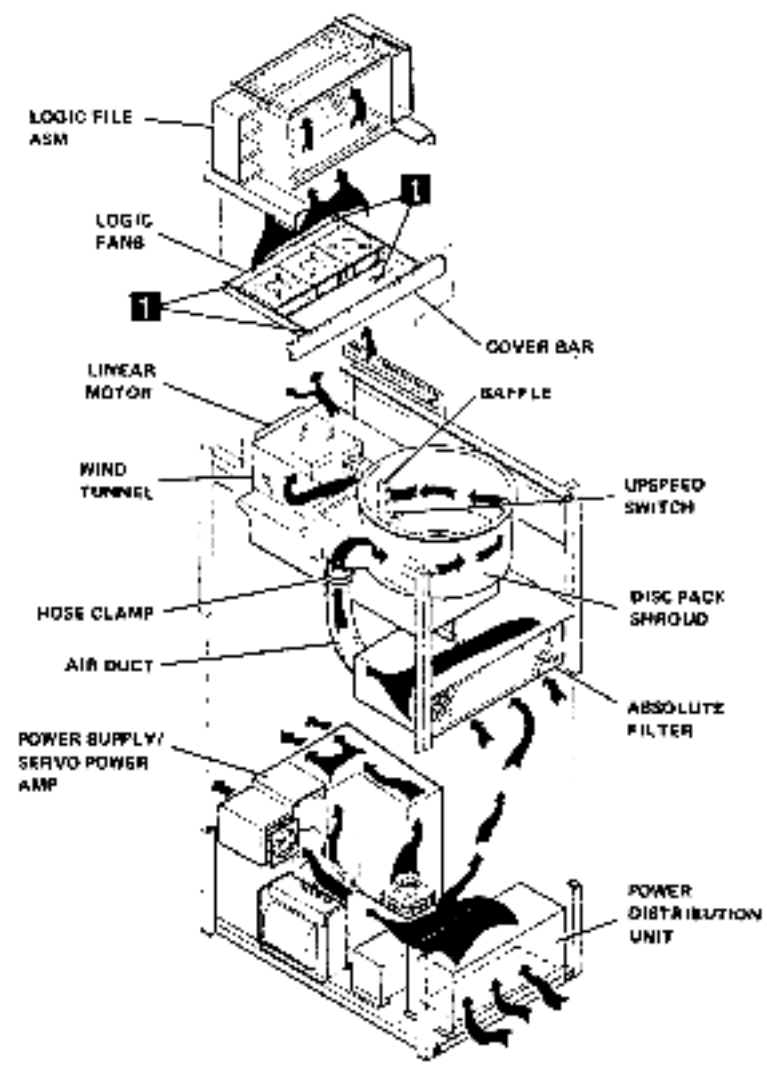

CP-9788

Figure 3-1 Air Flow and Filtration System

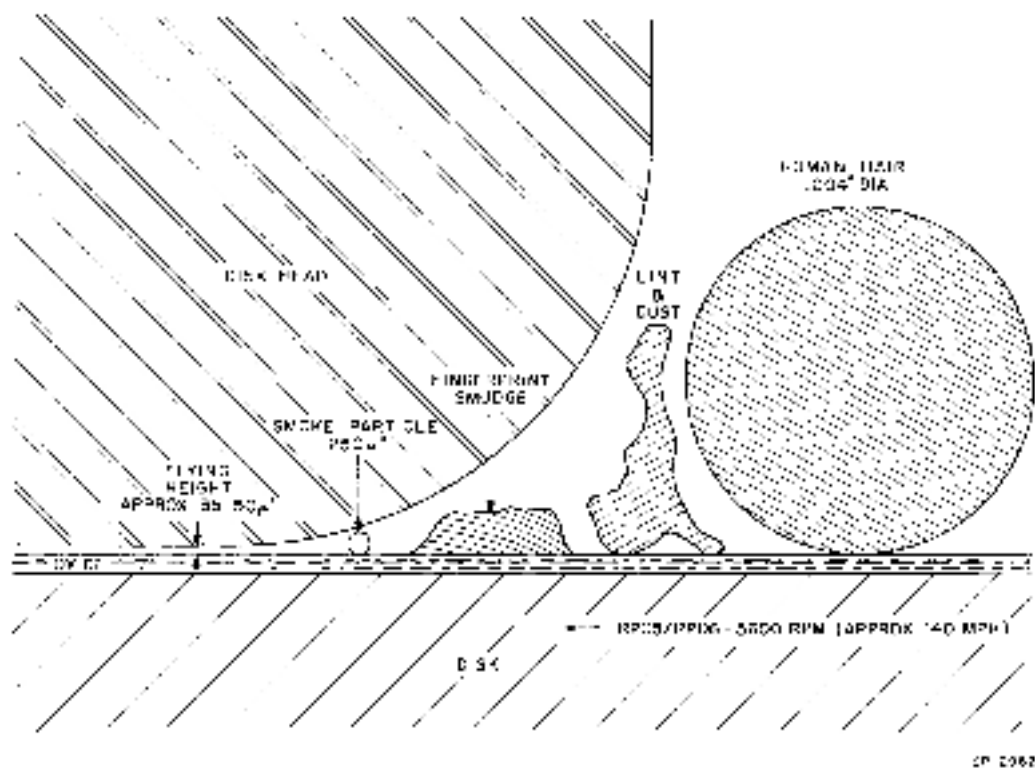

Figure 3-2 Disk Pack Relationship of Disk Head, Disk, Contaminants

CHAPTER 4 INSTALLATION

This chapter includes the procedures required to unpack and install the RP05/RP06 Disk Drive. The RP05/RP06 is designed to be installed as a remote device with control logic contained in an attached drive control logic (DCL) unit (Figure 1-3).

4.1 UNPACKING AND INSPECTION

The RP05/RP06 Disk Drive weighs approximately 272 kg (600 lb), and can be moved or lifted by a forklift or similar handling equipment. Table 4-1 lists special tools and equipment that would be required during an RP05/RP06 installation (Figure 4-1).

CAUTION

When moving or lifting the RP05/RP06 Disk Drive, always grasp the frame structure. Do NOT hold any part of the top or side covers.

The procedure for unpacking the RP05/RP06 is as follows.

1. The RP05/RP06 is shipped on a shipping skid, covered by a cardboard carton. Remove the two plastic straps that hold the disk pack on top of the carton, then remove the disk pack.
2. Remove the staples that fasten the four wooden slats to the bottom flanges of the cardboard-overlapped carton.
3. Remove the cardboard-overlapped carton.
4. After removing the hold-down bolts from the skid, install the leveling feet *before* removing the drive from the skid.
5. Remove the skid from under the drive.
6. Roll the RP05/RP06 to its designated location. Level it by lowering the eight levelers, removing all weight from the casters.
7. Remove the polyethylene bag that covers the RP05/RP06.

Table 4-1 Tools Required for RP05/RP06 Installation

Item	Part No.
Field Service Tool Kit	
Tektronix 453 oscilloscope, or equivalent	
<p>NOTE Oscilloscopes or meters used in the field should be calibrated frequently. Meter readings must be accurate within ± 1 percent, oscilloscope within ± 3 percent.</p>	
RP05/RP06 Disk Storage Subsystem Tester	
Absolute filter gauge	29-21290
C.E. Pack 3336 For RP05 For RP06	29-21292 29-22193
Data pack For RP05 For RP06	RP04-P RP06-P

NOTE

The Mechanical Alignment Kit (Capital Equipment) may be required if problems arise during installation of RP05/RP06 Disk Drives.

**RP06/06 DISK STORAGE
OFF-LINE TESTER**

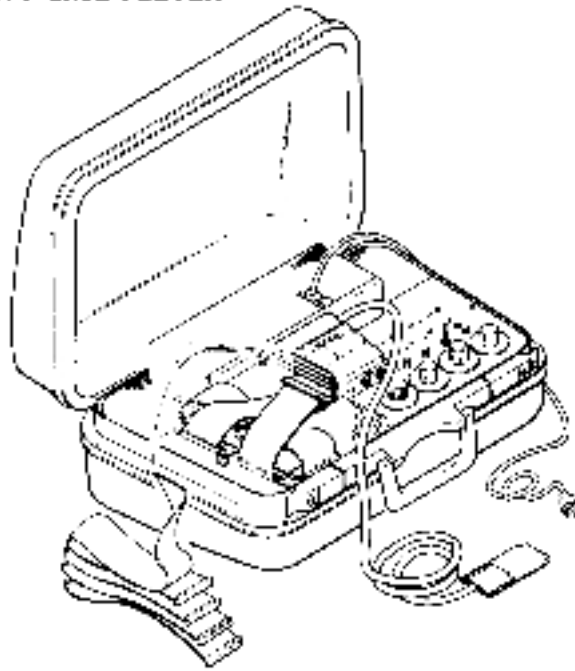

ABSOLUTE FILTER GAUGE (29-21290)

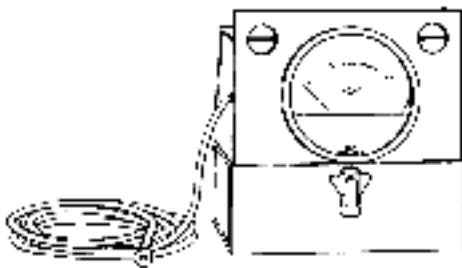

PCB EXTENDER (29-22190)



HEAD ALIGNMENT TOOLS

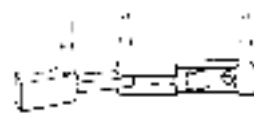

**HEAD INSTALLATION TOOL
P/N 29-22180**

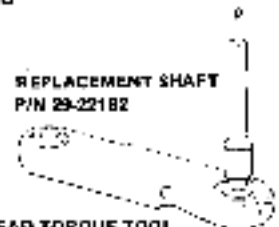

**REPLACEMENT SHAFT
P/N 29-22182**

**HEAD TORQUE TOOL
P/N 29-22181**

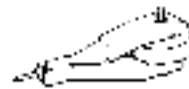

**HEAD ALIGNMENT TOOL
P/N 29-22179**

**HEAD CLEANING KIT
P/N 29-22563**



ALCOHOL

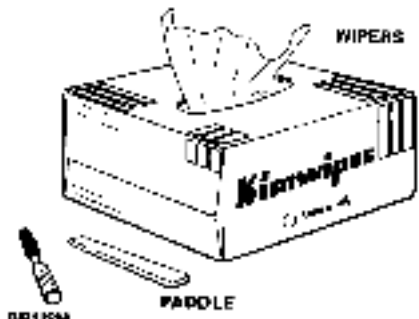

BRUSH

PADDLE

CP-2700

Figure 4-1 Special Tools for RP05/RP06 Installation (Sheet 1 of 2)

**MECHANICAL ALIGNMENT KIT
P/N 29-22183**

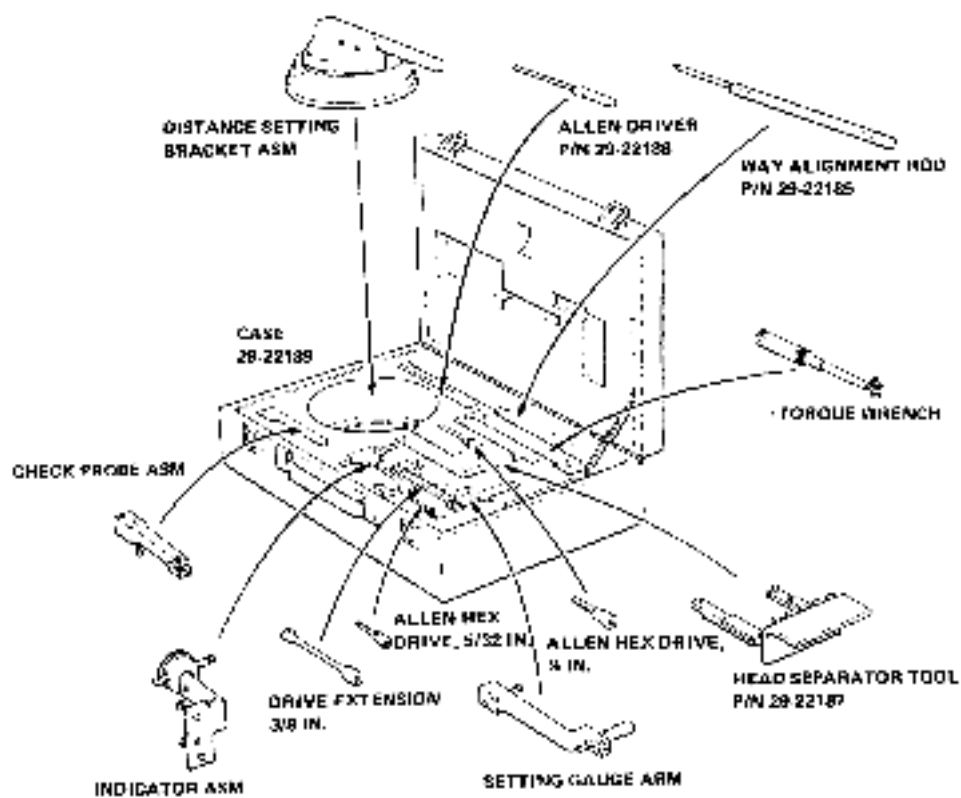

CP 2/87

Figure 4-1 Special Tools for RP05/RP06 Installation (Sheet 2 of 2)

8. Remove the package resting on top of the RP05/RP06; verify that it contains the following:

Item	Part No.
Skirts (7)	7411193
Screws (8)	9006418-1
Lock washers (8)	9006690
Flat washers (8)	9006661
Power sequence cable	7009491-0-1
Massbus cable*	7012066
Ground wire strap	7412827-03-0

*One each for single-access unit; two each for dual-access unit.

9. Remove the tape from the door end panels.
10. Visually inspect the exterior of the RP05/RP06 for evidence of shipping damage. Retain the original packing materials and receipts in case any claims are filed for shipping damage. All damage claims should be promptly filed with the transportation company involved, and Digital Equipment Corporation should be notified immediately of any such claim.
11. Remove all service covers for inspection.

NOTE

Side covers are not used between drives that are to be installed side-by-side in the string configuration. Only exposed sides should be covered.

12. Locate the door lock override mechanism (Figure 4-2), which is an arm that protrudes from the door lock solenoid. While pressing this mechanism downward, push the door and start sliding it toward the rear. Release the mechanism, and push the access door all the way back.
13. Manually turn the spindle in a counterclockwise direction to verify that it spins freely. Depress the cone-shaped pack-lock actuator at the right front of the spindle; manually turn the spindle in a clockwise direction. The spindle should lock to verify that it will hold the pack and permit disk pack top cover removal.

NOTE

The drive is transported with a shipping bracket installed to prevent carriage assembly motion during transit. Do NOT remove this shipping bracket yet.

14. Visually inspect the RP05/RP06; tighten all subassembly mounting hardware and all terminal connections. Access to the DCL unit backplane is gained by removing the rear cover. To then gain access to the logic modules, loosen the two thumbscrews at the top, pivot the assembly forward and down, and loosen two screws to remove the inside cover. To gain access to the DCL unit power supply, remove the front cover.

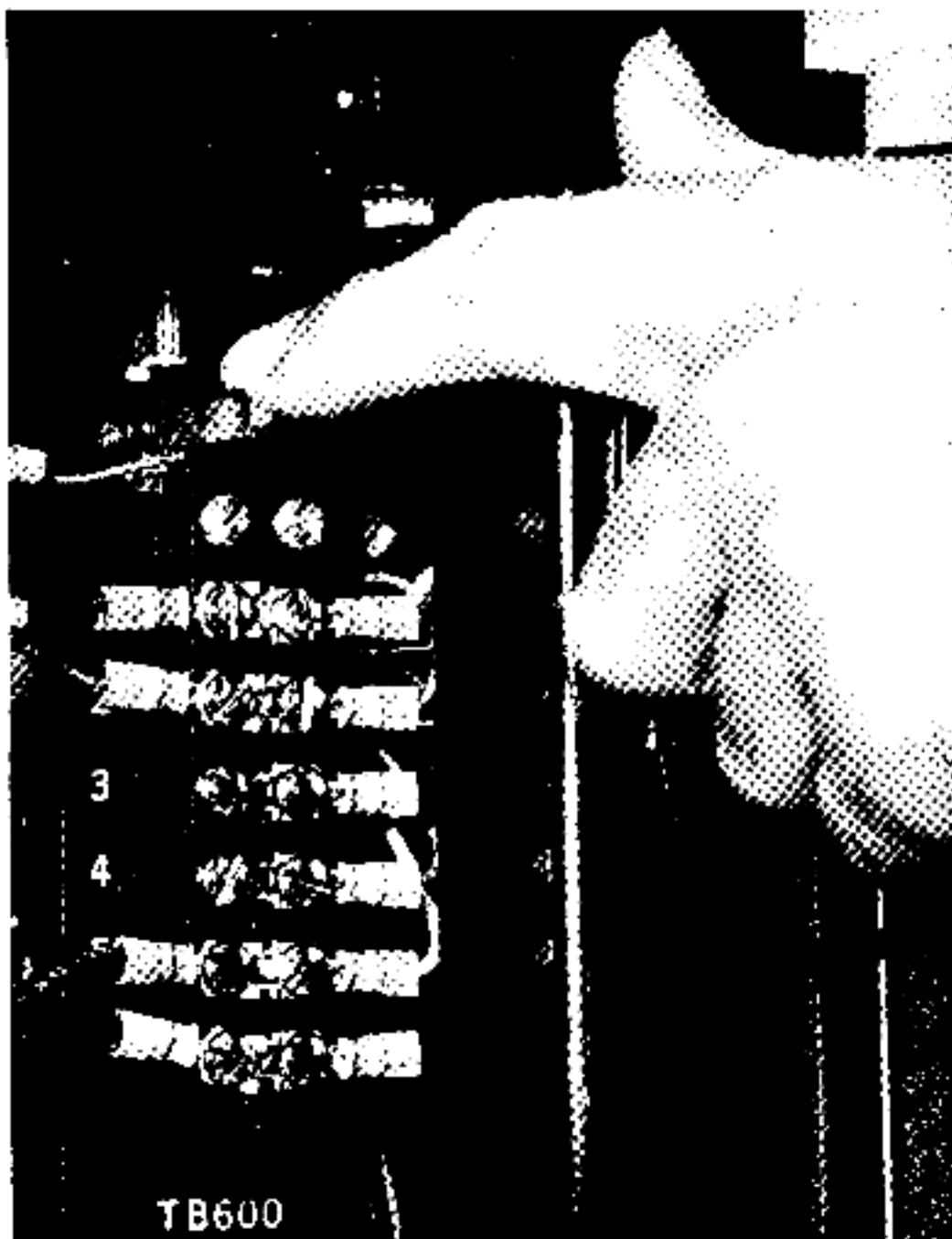

M-0521

Figure 4-2 Door Lock Override Mechanism

15. Check the drive power requirements on the nameplate (Figure 4-3) to verify that they agree with facility power. If a discrepancy exists, change the ac input power configuration of the RP05/RP06 to conform to available facility power (Paragraph 4.6). Verify that the power conversion plug is properly configured (Paragraph 4.6).

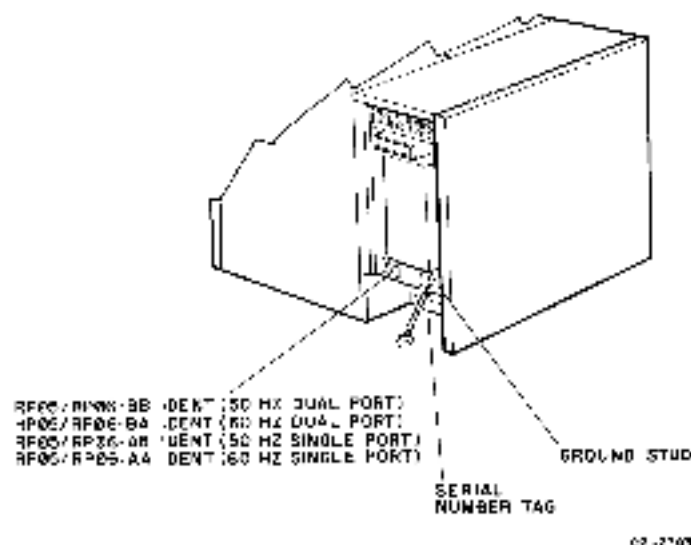

Figure 4-3 Location of Nameplate and Serial Number Tag

16. Check that matrix modules and head plugs are properly seated (Figure 4-4).
17. Visually check the cam-follower surfaces of all head/cam assemblies to verify that arms are properly engaged with cams on tower assemblies.

CAUTION

Never push the carriage forward so that the cam followers leave the cam unless the head separator tool is installed.

18. Check the four 40-pin ribbon cables (marked A, B, C, and D) that connect the drive to the DCU unit; ensure that the connectors are securely seated in the corresponding (A, B, C, or D) receptacle on module D01 or D02 (Figure 4-5).
19. Measure the electromagnetic actuator coil assembly (bobbin) resistance across the coil leads to determine that the resistance is 1.6 Ω (typical) and that no shorts or opens exist.
20. Remove shipping brackets from rear of deck plate and frame (Figure 4-6); provide room for accessing other shipping hardware by removing the absolute filter (Figure 4-7). (To remove the filter, reach through the left side of the drive with a screwdriver and remove the hose clamp at the rear of the filter, then slide the filter out.)

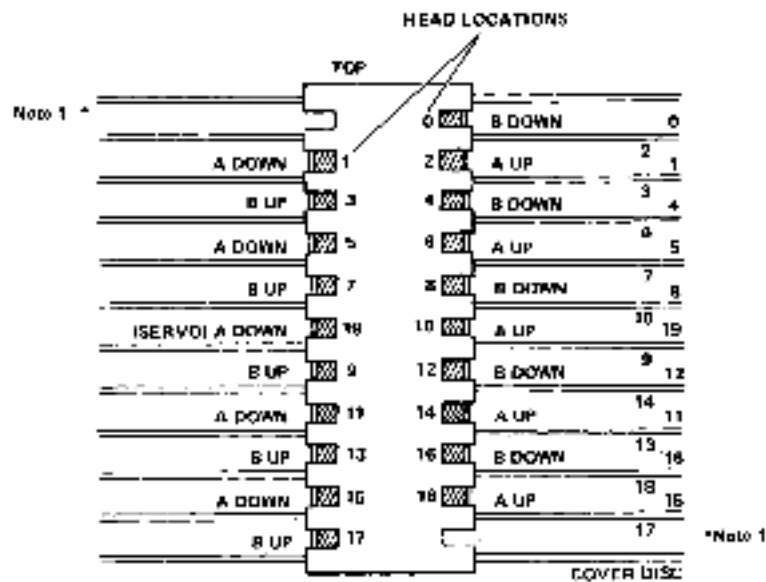

NOTES:

1. Do not attempt to install a head in three two locations. These slots are used only for the head separator reel.
2. Before installing a head, be sure that the etching (A-Up/Down, B Up/Down) agrees with the chart on the linear motor and the head position on the T-block.

CP-2785

Figure 4-4 T-Block Viewed from Linear Motor

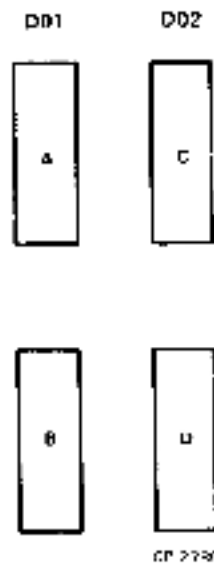

Figure 4-5 DCL/Drive Signal Interface Connections

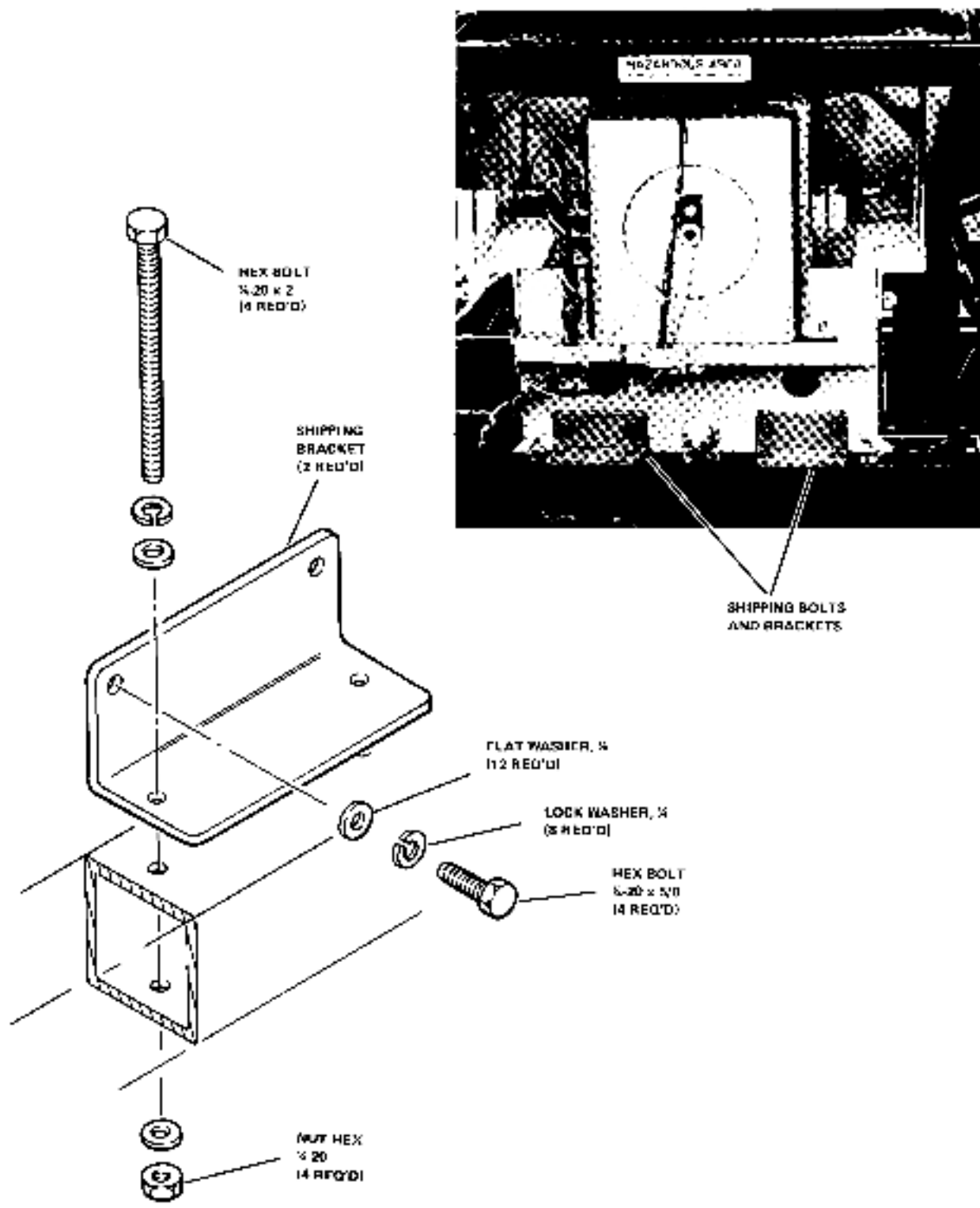
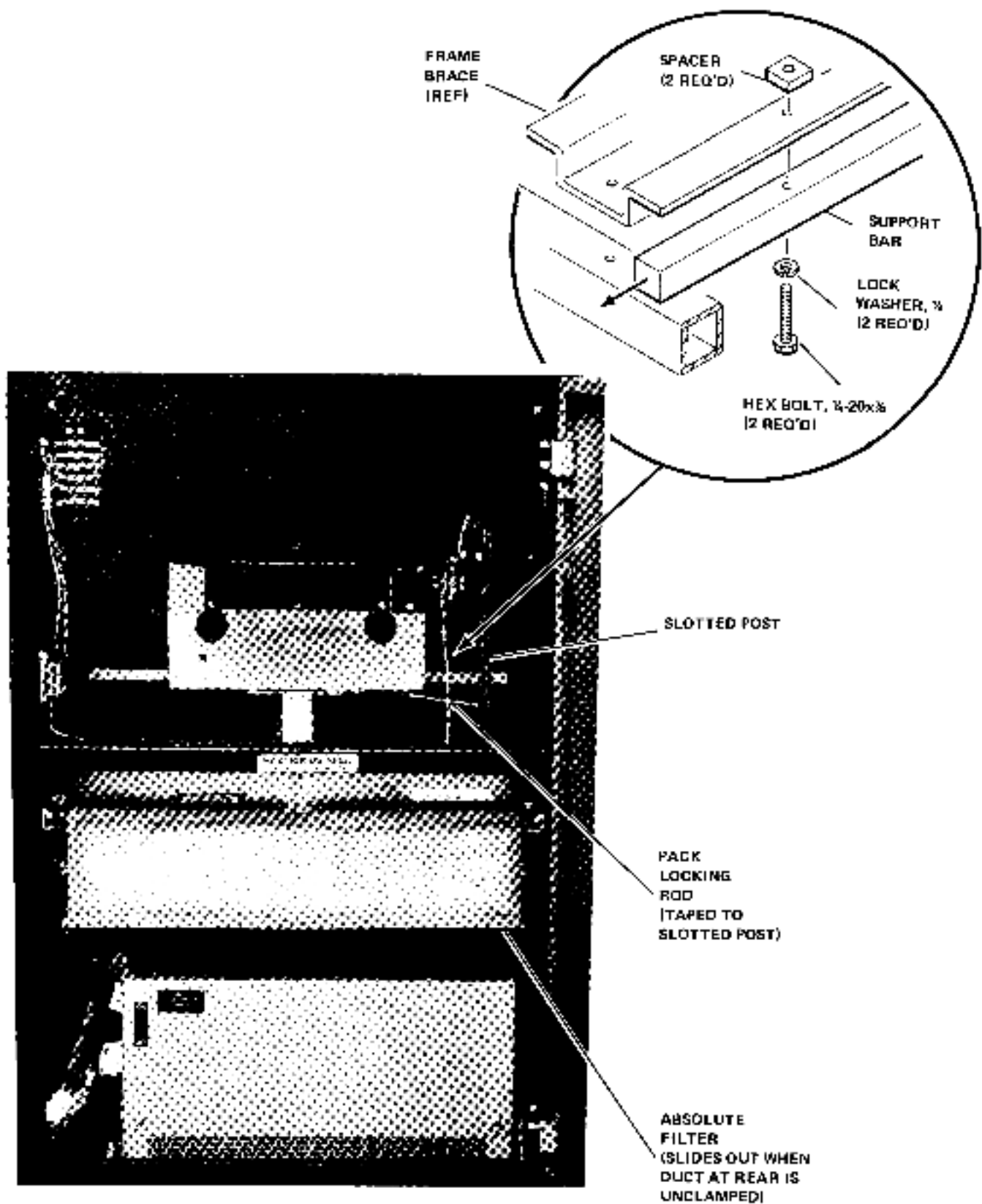

Figure 4-6 Shipping Brackets



M-0624

Figure 4-7 Absolute Filter and Pack Loading Rod

21. Remove two bolt washer spacer sets from the area between the frame and deck plate (Figure 4-8); remove the heavy support bar by pushing out from the side,

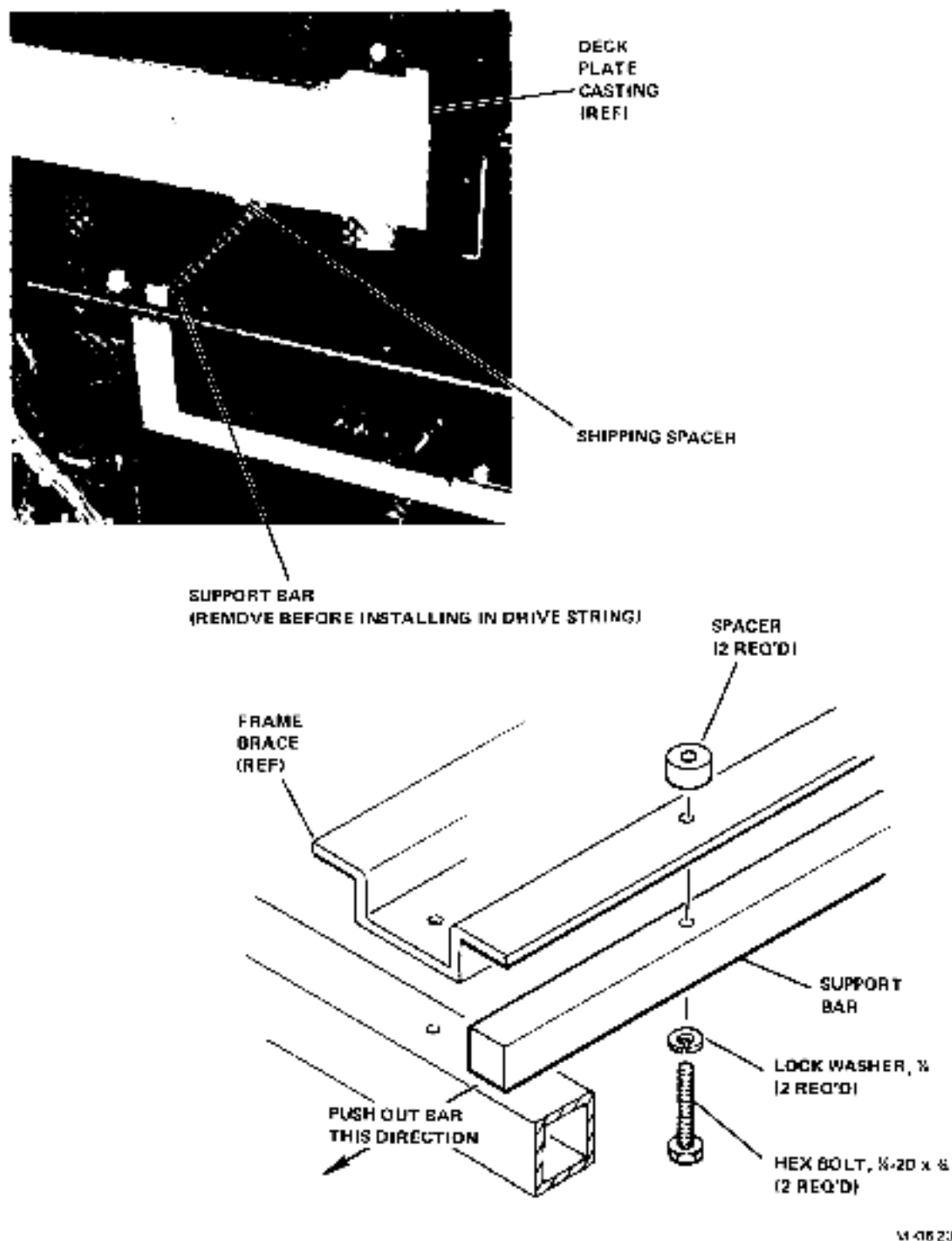

Figure 4-8 Shipping Spacers and Support Bar

22. Replace the absolute filter and clamp the hose to the rear of the filter.
23. Remove the tape (if any) wrapped around the disk pack locking rod and the slotted post (Figure 4-7); remove two strips of tape (if any) securing the wind tunnel (plastic deflector) to the deck plate. (To access the wind tunnel, swing open the rear cover of the drive.)
24. Remove shipping block on linear motor.
25. Replace all service covers removed in step 11, unless off-line checkout is to be performed at this time.

4.2 INSTALLING THE RP05/RP06

The first RP05/RP06 Disk Drive must be mounted within 12 m (40 ft) of the controller and within 4.4 m (15 ft) of a facility ac power source. The safety precautions should be observed while following the installation procedure in Paragraph 4.2.2.

4.2.1 Safety Precautions

Observe the following precautions to avoid injury to personnel or damage to the equipment.

1. Keep fingers and hands out of the area between the carriage and the disk pack while the drive is on.
2. Always remove ac power cables when it is necessary to work inside the drive sequencer assembly or on the transformer assembly terminals when the drive is not operating; high potentials of up to 230 Vac/60 Hz or 400 Vac/50 Hz are present.
3. Use only nonmagnetic tools near the linear motor, which includes an extremely powerful magnet. Use care when working in the linear motor area with magnetic materials, even though flux leakage is low in the pack area and outside the drive. Keep read/write heads away from the linear motor.
4. Avoid touching or blowing breath on read/write heads; skin acids can etch and ruin heads, and breath can cause condensation deposits that could disfigure the gliding surface.
5. Never manually move the carriage assembly forward without a spinning disk in place or the head separator tool installed.
6. Never remove or change modules without shutting down all internal drive power. Allow about 30 seconds for power supplies to bleed off.

4.2.2 Installation Procedure

1. Check that CH100 is OFF (Figure 4-9); then connect the power cable to the RP05/RP06. The cable to use for this purpose is:

70-6464-4	60 Hz
70-6464-3	50 Hz
2. It is possible to daisy-chain two 60 Hz drives to a single ac power source by plugging the power cable of the first directly into the source and connecting the first drive to the second by means of a 2.4-m (8-ft) power cable jumper (Part No. 7006600-1). Do not daisy-chain power to 50 Hz drives.



a. FRONT VIEW, PDU COVER OFF

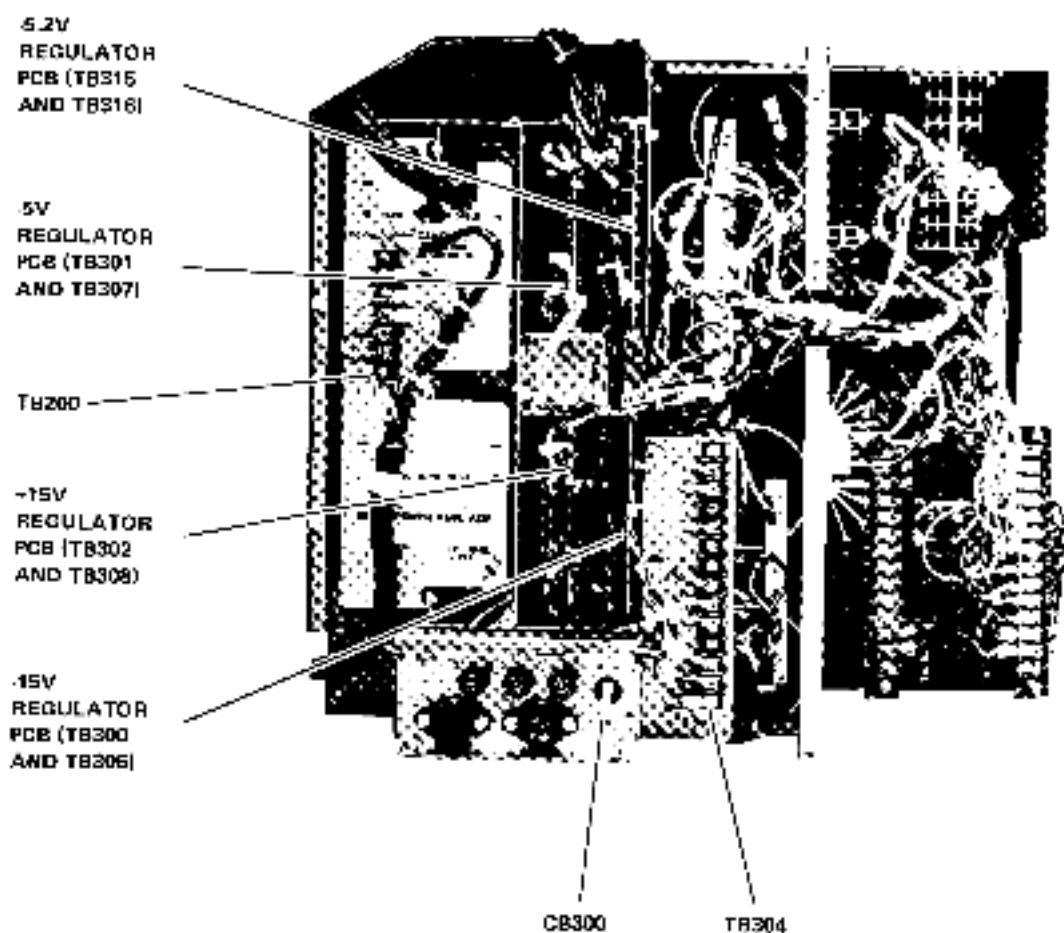

b. REAR VIEW, POWER SUPPLY COVER OFF

Figure 4-9 RP05/RP06 Installation

M 0625

3. Connect a 7.6-m (25-ft) ground wire (Part No. 741827-25) from the ground stud at the bottom of the DCL unit to the stud at the bottom of the cabinet containing the controller.
4. Check that the power sequence jumper (Part No. 7009490) is installed in J12 of the DCL unit. (Refer to drawing D-UA-RJP05-A-0 or D-UA-RJP06-A-0.)
5. Connect the round 7.6-m (25-ft) Massbus cable (BC06S-25) from the DCL unit connector marked "Controller A Input" (Figure 4-10) to the connector panel in the controller cabinet. Ensure that the drive end of this cable is bent at an angle of 90 degrees to the cable gate (Figure 2-3).

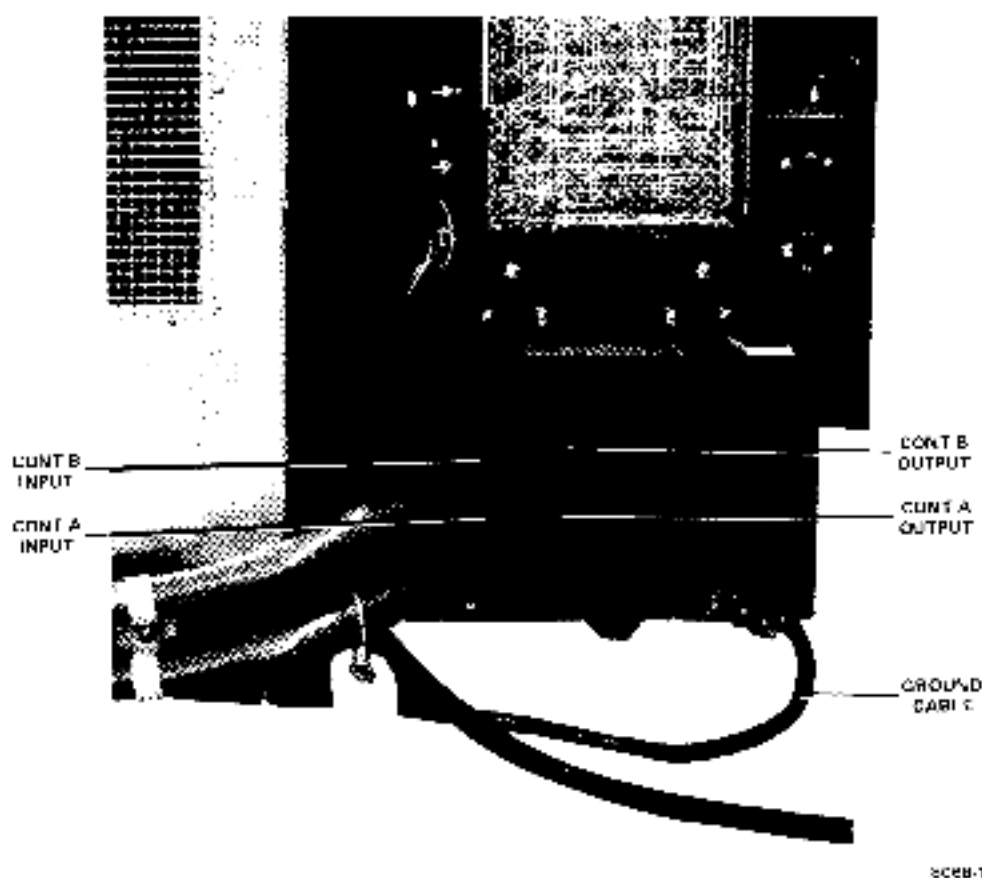

Figure 4-10 RP05/RP06 Connector Panel

6. If the installation is multidrive, proceed to step 7; otherwise, proceed to step 11.
7. Connect a round 76-cm (30-in) Massbus cable (7012066) from the DCL unit connector marked "Controller A Output" to the connector in the second drive marked "Controller A Input." Install cable clamps as shown in Figure 4-11.

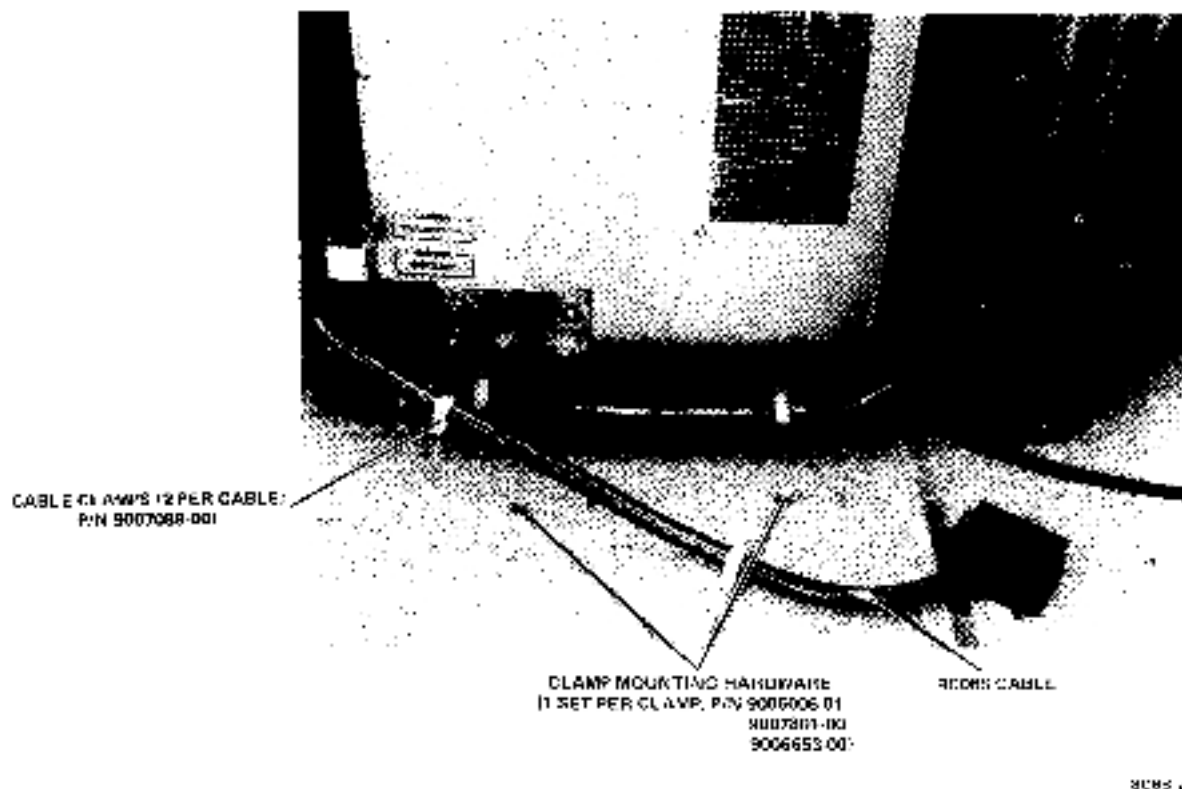
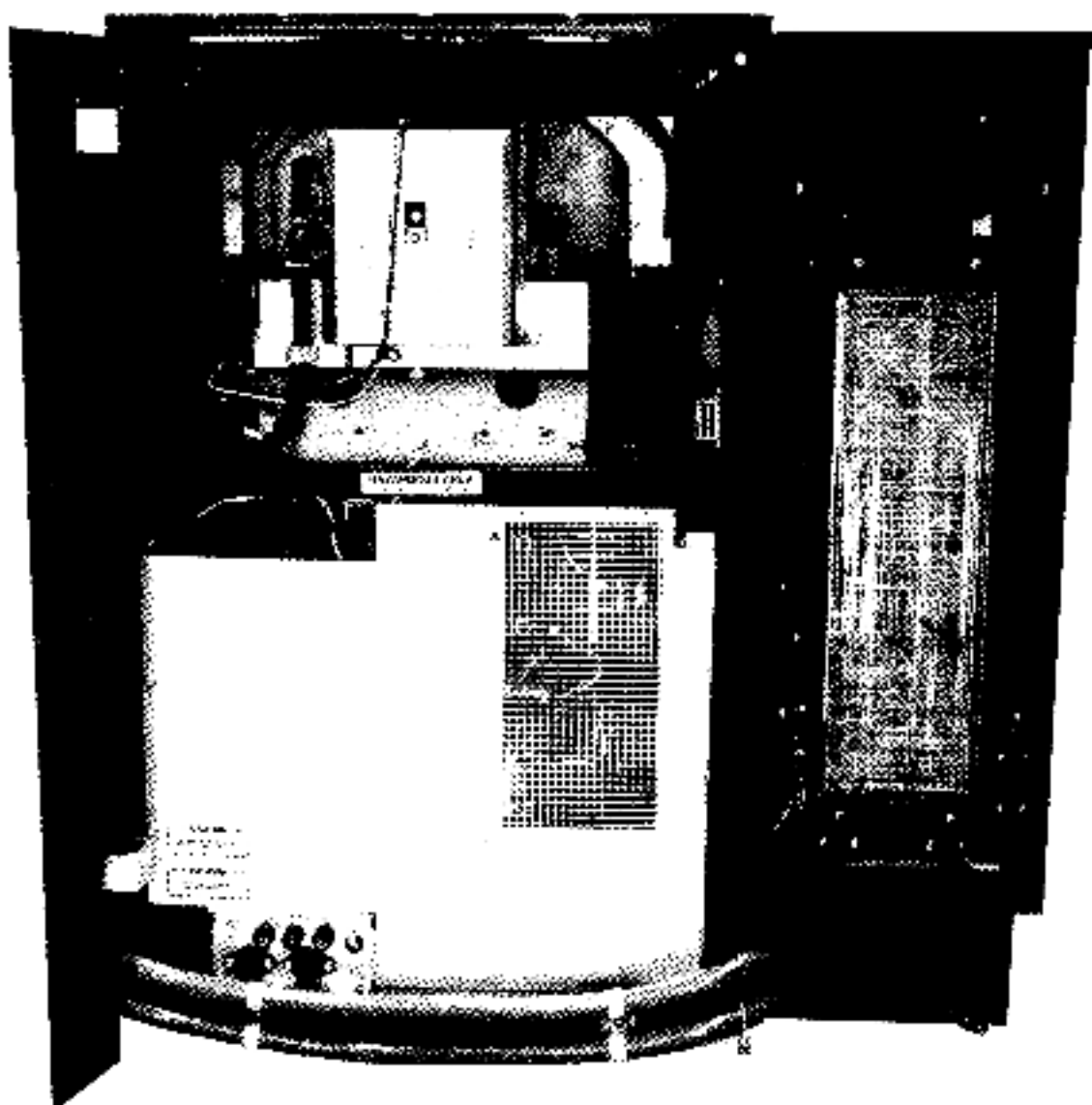

Figure 4-11 Massbus Connector Prior to Mounting

8. Repeat step 7 for each additional drive in the configuration.
9. Daisy-chain all drives by connecting 0.9-m (3-ft) ground wires from one DCL unit stud to the next.
10. Daisy-chain all drives by connecting 0.9-m (3-ft) power sequence cables (7009491-1) from J13 of the preceding drive to J12 of the next. For the first drive, a power sequence jumper should be connected to J12.
11. For the last drive, connect a Massbus terminator pack assembly (7009938) to the DCL unit connector marked "Controller A Output" (Figure 4-10).

NOTE

For a dual-controller configuration (drawing E-UA-RJP05-B-0 or E-UA-RJP06-B-0), install the second Massbus per the above pattern. Use the DCL unit connectors marked "Controller B Input" and "Controller B Output." A second Massbus terminator must be used in the last drive. The second controller may be mounted in the same cabinet as the first, or in a different one. If the same box is used, a second receptacle housing is mounted in the connector panel to accommodate the second Massbus; if different cabinets are used for the controllers, two connector panels are necessary.



9088 1

Figure 4-12 Massbus Connector Mounted

12. Lower the logic nest assembly in DCL unit and remove the rear cover.
13. Verify that the drive unit number switches on the M7787 module are all in the OFF position.

NOTE

Any switch left in the ON position will force the corresponding bit position in the unit number to zero.

14. Verify that the drive-type jumpers on the M7776 module are configured to reflect the proper type of drive, as follows:

Drive	W1	W2
RP05	IN	OUT
RP06	OUT	IN

If the serial number option is required, check board M7776 and configure jumpers according to the drive serial number.

4.3 INSTALLATION CHECKS AND ADJUSTMENTS

To verify performance and adjust the RP05/RP06, perform the various installation checks and adjustments described in the following paragraphs.

4.3.1 DCL Unit Power Supply Voltage Checks

The DCL unit power supply develops three dc output voltages (+5 Vdc, -15 Vdc, and +15 Vdc), and is constantly monitored by a power monitor unit. Turning ON the CBI circuit breaker at the base of the drive and the circuit breaker at the rear of the DCL unit activates the DCL unit power supply. The heavy dotted line in Figure 4-13a indicates the chassis outline; the lighter dotted lines indicate the two regulator board modules, A1 and A2. A1 is accessible from the front of the DCL unit; A2 is accessible from the rear. Figure 4-13b and the following paragraphs describe the functions of the two regulator board modules.

4.3.1.1 Regulator Board Module A1 – Regulator board A1 issues the following.

1. AC LO and DC LO to the power monitor – If these voltages should fail, the power monitor will set error flags.
2. +5 Vdc to the power monitor and to the DCL unit backplane – This voltage should be viewed on the DCL unit backplane (AA2 slot 1) and adjusted on the power supply.
3. -15 Vdc to the DCL unit backplane – This voltage should be viewed at the backplane (AB2 slot 1) and adjusted on the power supply.
4. +15 Vdc is not used and not monitored.

4.3.1.2 Regulator Board Module A2 – Regulator board A2 issues the following.

1. AC LO and DC LO to the power monitor – If these voltages should fail, the power monitor will set error flags.
2. +5 Vdc to the power monitor and to the DCL unit backplane – This voltage should be viewed on the DCL unit backplane (AA2 slot 9) and adjusted on the power supply.
3. +15 Vdc to the power monitor – This voltage should be viewed on the power monitor (plug 10, pin 5) and adjusted on the power supply.
4. -15 Vdc is not used and not monitored.

CAUTION

To avoid possible damage to the equipment or to the electrical system, do not adjust voltages beyond on the limits shown in Table 4-2.

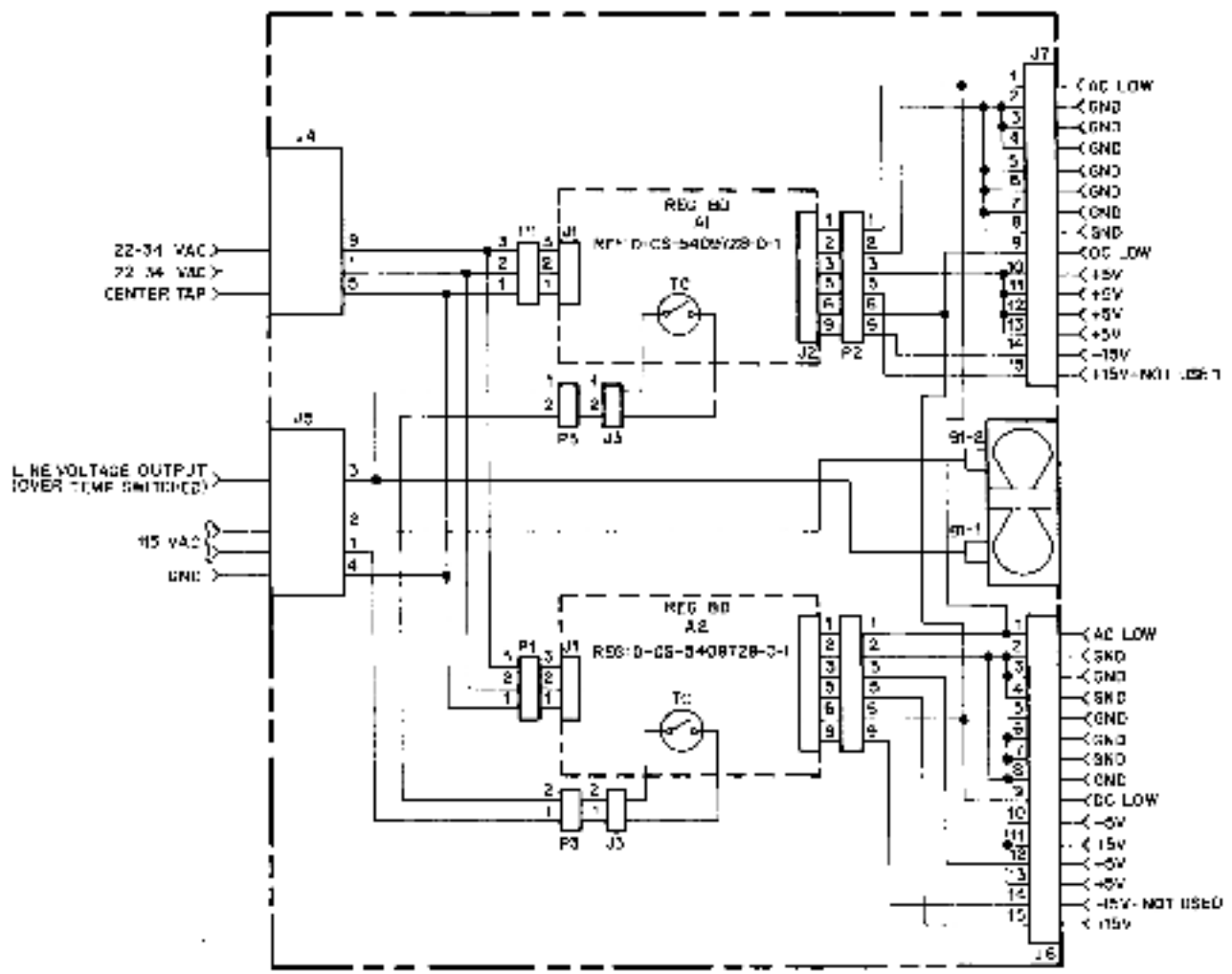

a. DCL Unit Power Supply Schematic

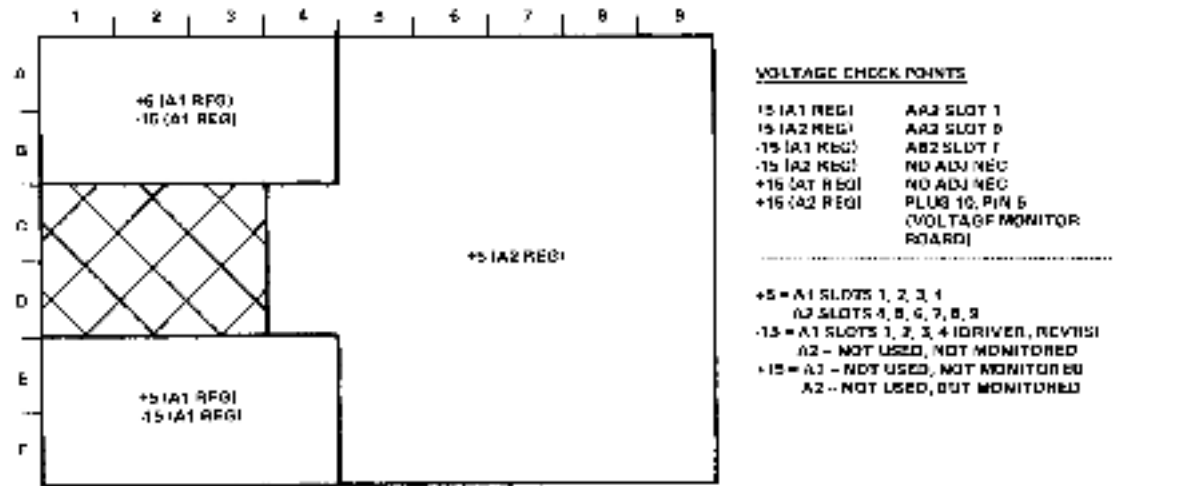

b. DCL Unit Voltage Checks

Figure 4-13 Power Distribution (DCL Unit)

Table 4-2 DC Voltages

Minimum	Nominal	Maximum	
+4.9	+5	+5.2	
-5.3	-5.2*	-5.1	
+14.7	+15	+15.3	
-15.3	-15	-14.7	
+19.0	+24	+29.0	} Not Adjustable
+45.0	+50	+55.0	

*At 1B500A terminal No. 3, not marked as -5.2.

4.3.2 Drive Power Supply Voltage Check**CAUTION**

Ensure that CBI is OFF before changing the position of any other circuit breaker.

Perform ac and dc power checks for the drive(s) as described in the following paragraphs.

4.3.2.1 AC Power Checks – Perform ac power checks as follows.

1. Set CB100 on the RP05/RP06 power distribution unit (PDU) to ON. (See Figure 4-9a.)
2. Verify that three fans located under the logic gate and two fans in power supply are operating (Figure 4-9b).
3. Verify that door interlock latch is released by sliding open the glass door.
4. Repeat steps 1, 2, and 3, above, for each drive in the installation.

4.3.2.2 DC Power Checks – Perform dc power checks as follows.

1. Momentarily press LAMP TEST on the operator panel; verify that all indicators are illuminated.
2. Set CB300 on the power supply to ON. (See Figure 4-9b).
3. Using a digital voltmeter, measure voltages at the back panel and compare them to the specifications in Table 4-2. With the one exception noted in the table, the measurement locations are etched onto the back panel itself, using their nominal voltage values. If adjustment is necessary, adjust these voltages as near the nominal values as possible.
4. Repeat steps 1 through 3, above, for each drive in the installation.

4.3.3 Readiness Tests

Test the drive(s) for readiness as follows.

1. Inspect and clean (as required) all heads in the drive, as described in Paragraphs 4.5.1 and 4.5.2.

2. Mount a scratch pack on the drive. Remove the logical address plug from the operator panel.

NOTE

The logical address plugs on the RP05 and RP06 can be removed simply by pulling them out.

3. Press the START/STOP switch to START. START and DOOR LOCKED should light, and the spindle should start spinning. Allow the drive to come up to speed and purge for 5 minutes. With the logical address plug removed and without a first launch, hand load heads very carefully. Check for binding or unusual noise that might indicate head-to-disk interference (HDI). (For clues on HDI detection, refer to Paragraph 4.3.5.8.) If HDI is observed, retract the heads, turn the drive OFF, and investigate the problem.
4. Install the any-numbered logical address plug; this will allow the heads to launch to track 000. Remove and reinstall the logical address plug; the drive should do a re-zero.
5. Verify the capability of the drive to execute a seek operation by using the off-line tester and running routines 01 through 03.
6. Perform the head alignment procedure described in Paragraph 4.5.5, using the off-line tester. Before starting head alignment, be sure that the drive is in the Write Protect mode and allow 30 minutes for thermal stabilization of drive and CE pack.

Repeat steps 1 through 6, above, for each drive in the installation.

NOTE

At this stage in the installation procedure, the following activities should be performed.

1. Verify correct system cabling and signal termination in the DCL unit.
2. Use system diagnostics to verify the presence of an operational condition in each drive.
3. Use system diagnostics to perform the system head alignment verification procedure.

4.3.4 Drive Cycle Up/Down Checks

To check the starting and stopping of the spindle motor, ensure that a logical address plug is installed, a disk pack is installed, and the glass access door is closed, then proceed as follows.

1. Verify that all lamps light by pushing the Lamp Test switch. This also indicates that main power is applied to the drive. If UNSAFE lights, indicating an unsafe condition, proceed to Paragraph 4.3.5.1 to clear this condition. When it is cleared, proceed to step 2, below.
2. Press the START/STOP switch to the START position, triggering the following series of events: START illuminates, DOOR LOCKED illuminates, and the pack begins to rotate. If DOOR LOCKED does not illuminate, close the door fully.

3. Wait approximately 20 seconds until the word **READY** illuminates, indicating that the drive is started and ready to execute commands. **START** and **DOOR LOCKED** should remain illuminated.
4. Stop the drive spindle motor by pressing the **START/STOP** switch to **STOP**. This extinguishes the **READY** and **START** lights, and causes the drive to retract heads. The **DOOR LOCKED** light is extinguished approximately 20 seconds later, when the motor-down sequence has been completed.

NOTE

The system can stop the drive motor by issuing a command to place the drive in Standby mode. Whether stopped by the system or the operator, the resulting status of indicators is the same, except that a stop by the system causes **STANDBY** to illuminate.

4.3.5 Response to Abnormal Conditions

4.3.5.1 Clearing an Unsafe Condition – A sequence malfunction during a start operation causes **UNSAFE** to illuminate and initiates an abnormal stop sequence in the drive. At the end of that sequence, the spindle should come to a complete stop. Pressing the **START/STOP** switch to **START** clears the unsafe condition and restarts the drive; if **UNSAFE** does not disappear or if it reoccurs during the normal starting sequence, corrective maintenance is necessary.

CAUTION

Any malfunction of the stop sequence (e.g., failure of the spindle to stop at the end of the sequence) requires corrective maintenance; do **NOT** attempt other operations. If it is necessary to remove ac power from the drive, first unload the heads manually.

4.3.5.2 Removing a Pack With No Drive Power – To remove a pack from a drive with no ac power applied, proceed as follows.

1. Verify that the spindle is stopped and the heads are retracted.
2. Pull open the drive's front cover. Referring to Figure 4-2, locate the door lock override mechanism; it is an arm protruding from the door lock solenoid. Press the mechanism downward, and while holding down, push the door and start sliding it toward the rear. Release the mechanism and push the access door all the way back.
3. Lower the top cover straight down over the pack, carefully avoiding contact with the edges of the disks. Turn the handle on the top cover two full turns counterclockwise.
4. Using the handle, remove the pack from the drive.
5. Immediately attach the bottom cover to the pack, and store.

4.3.5.3 Detecting Head-to-Disk Interference – Head-to-disk interference (HDI) results from head contact with a disk surface, usually the result of a foreign particle in the air stream or a protrusion from the disk surface causing the head to break through the air bearing and abrade the disk surface. This problem, if not corrected, can be propagated from pack to pack and, ultimately, from drive to drive. HDI symptoms include:

1. Sudden hard read errors
2. Black contamination on flying surface of any head
3. UNSAFE illuminating during a write operation
4. Uncommon noise from the disk, such as audible tinkling, zinging, or scratching, which become gradually louder toward a screech.

If any of the above symptoms are detected, stop the drive immediately.

CAUTION

1. If the suspected pack is replaced with another pack and the drive is operated, or if the suspected pack is used in another drive, damage to either the second drive or the substituted pack may well occur.
2. All packs and drives in use when HDI symptoms are detected must be checked for HDI by service personnel.

4.4 TESTER HOOKUP, ROUTINES, AND RUN OPTIONS

4.4.1 Tester Hookup

Hook up the RP05/RP06 Disk Storage Subsystem Tester (Figure 4-14) as follows.

1. Connect the tester to 115 Vac, 50/60 Hz wall power, and run Wrap Test for tester checkout. If no error occurs, proceed to step 2.
2. Turn off ac power to the drive and DCL and place the START/STOP switch in the STOP position.
3. Disconnect the drive from DCL I/O cables A, B, C, and D.
4. Connect tester I/O cables A, B, C, and D to the drive. Cables should be installed so that the "rib" sides of cables A and C face each other and B and D face each other.
5. Connect the tester's head alignment cable to the drive in slot B04 (Figure 4-15).
6. Connect the drive to ac wall power and set all ac/dc circuit breakers to on. STANDBY, READY, DOOR CLOSED, CTRL A, B, and UNSAFE should *not* be lit.
7. Press RESET in tester; all tester LED (light-emitting diode) displays should illuminate. Release RESET; all LED displays should extinguish.

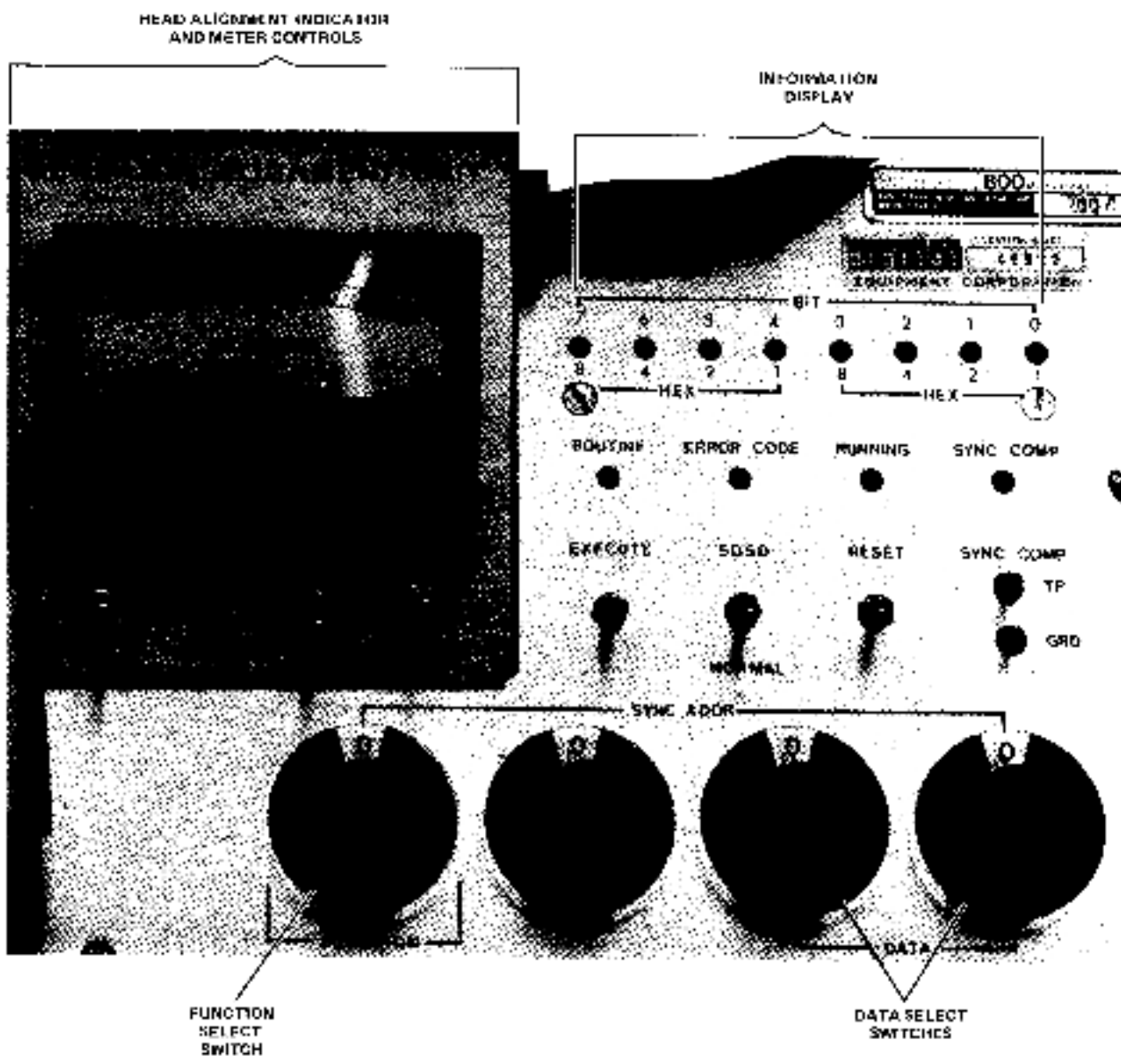

0214-2

Figure 4-14 RP05/RP06 800 Disk Storage Subsystem Tester

9. Toggle Reset on tester and observe that all indicators go off except STANDBY.
10. Depress START/STOP switch on the drive to START position. Observe that STANDBY indicator goes off.
11. Press Reset on tester. START indicator will light. If door is closed, DOOR LOCKED will light and spindle will now start spinning.
12. Heads will not load until a test routine is executed. Pressing reset on the tester will cause heads to retract and unload.
13. Perform the routines listed in Table 4-3 to verify operation of the drive. Details of these tests are contained in Appendix B of the *Memorex RP05/RP06 677-01/51 DEC Disk Storage Drives Technical Manual (ER-00012)*. Table 4-4 describes function switch operations. Some of the routines are expressed in hexadecimal form (base 16); Table 4-5 contains a conversion procedure between decimal, octal, and hexadecimal numbers.

Table 4-3 Tester Routine Numbers and Run Options

Routine	Test	Run Time (sec)*	Error Control/Run Options
00	Wrap	<1	01 = Loop on pass. 02 = Loop on error.
01	Incremental Seek	<1	01 = Run continuously and stop on error (default). 02 = Loop on error
02	Alternate Seek	<1	01 = Alternate seek stop on error. 02 = Loop on error.
03	Random Seek	<1	01 = Run continuously and stop on error (default). 02 = Loop on error.
04	Tachometer Gain Adjustment	<1	00 = Verify tachometer gain (no link). 01 = Adjustment mode 02 = Loop on error. 80 = Verify tachometer gain and link (default).

*Time required for one loop through the routine.

Table 4-3 Tester Routine Numbers and Run Options (Cont)

Routine	Test	Run Time (sec)*	Error Control/Run Options
05	Head Alignment	<1	01 = Run continuously and stop on error (default). 02 = Loop on error.
06	Head Alignment Verification	≈10	00 = Verify mode (default). 02 = Loop on error.
07	Head Alignment Track Seek	<1	00 = Run once and stop (default). 02 = Loop on error.
08	Write Read Verification	<2	00 = Write all heads of cylinder and stop (default). 02 = Loop on error.
09	Incremental Offset Read	<2	00 = Read once and stop (default). 01 = Read continuously and stop on error. 02 = Loop on error.
0A	Read Continuously (Errors Monitored)	≈20 min	01 = Read 65,535 times and stop (default). 02 = Loop on error.
0B	Read Write Safety	<1	00 = Check latches once (no link). 02 = Loop on error. 80 = Check latches once and link (default).

*Time required for one loop through the routine.

Table 4-3 Tester Routine Numbers and Run Options (Cont)

Routine	Test	Run Time (sec)*	Error Control/Run Options
0D	Offset	<1	00 = Run once and stop (no link). 01 = Run continuously and stop on error. 02 = Loop on error. 80 = Run once and link (default).
10	Index	<1	00 = Run once (no link). 01 = Run continuously and stop on error. 02 = Loop on error. 80 = Run once and link (default).
11	Display Drive Output Byte	<1	00 = Display one drive output byte. Byte number 00 (default).
12	Recalibrate	<1	00 = Run once (default). 02 = Loop on error.
13	Write	<1	00 = Write all heads of cylinder and stop. 01 = Write continuously and stop on error. 02 = Loop on error.

NOTE

Error code dictionaries and flowcharts for tester routines are contained in Appendix B. An error code of "FF" indicates successful completion of the test.

*Time required for one loop through the routine.

Link Options: Routines 0D, 10, 04, 0B, and 08 can be linked together to provide automatic consecutive execution of these routines. To run, load Routine 0D into function 1. Switch to function 0 and execute. An error code of "FF" indicates successful completion. Executing function F will display the last routine run if successful completion did not occur.

Table 4-4 Function Switch Operations

Function Position	Function Operation	Data Switch Entry	Comments
0	Execute routine	N/A	Executes the routine defined by function 1.
1	Enter routine to be run	XX	XX = the number of the routine to be run.
2	Enter parameter data	XX	Enters parameter data XX in the byte defined by function 3. Automatically increments to the next byte number at execution of this function.
3	Enter parameter byte	XX	XX = Parameter byte number to be operated on.
4	Display parameter byte	N/A	Displays parameter data of byte defined by function 3. Automatically increments the next byte number after execution of this function.
5	Error control/run options	XX	XX = Option code for routine to be run.
6	Advance head	N/A	May be selected only where head alignment feature is installed in the tester and the head alignment routine is running.
F	Display routine number	N/A	Displays the number of the routine just executed.

Table 4-5 Hexadecimal-Octal Conversion

Decimal	Binary	Octal	Hexadecimal
0	0000	0	0
1	0001	1	1
2	0010	2	2
3	0011	3	3
4	0100	4	4
5	0101	5	5
6	0110	6	6
7	0111	7	7
8	1000	10	8
9	1001	11	9
10	1010	12	A
11	1011	13	B
12	1100	14	C
13	1101	15	D
14	1110	16	E
15	1111	17	F

4.5 HEAD CLEANING

4.5.1 Head Inspection Procedure

Remove the disk pack and inspect the heads for evidence of brown streaks or residue on the white-colored sliders. Use of the dental inspection mirror permits an unobstructed view of each head surface. If a head faces upward, a better view of the head surface may be obtained by pushing the cam surface of the head arm down slightly with one finger. The downward-facing head directly above can also be inspected at this time via a dental mirror, which will also provide an unobstructed view of the upper head slider.

CAUTION

Do not touch the face of read/write heads with fingers or dental mirror. Oil from the skin can cause deposits of foreign materials to build up. Do not leave any residue or lint on the head. Do not blow on the head, as moisture from breath causes contamination.

4.5.2 Possible Head Conditions

Head inspection should categorize the head slider in one of the three conditions described in the following paragraphs.

4.5.2.1 Clean Head – If the head slider is clean and white, with no visible indications of lint or foreign material, no cleaning is required.

4.5.2.2 Dirty Head – If there is brown residue on the trailing edges of the slider, the head is dirty and needs cleaning.

4.5.2.3 Head/Disk Interference – If there are light brown or dark brown streaks across the face of the slider, head/disk interference (HDI), or *head crash* is indicated. In this case the head(s) should be removed and replaced.

CAUTION

If evidence of HDI is detected, all packs that have run on the affected drive should be isolated. These packs will require surface cleaning and inspection, or possibly a refurbishing by the vendor, before they can be run again on ANY drive. Failure to observe these precautions could result in further head crashes and damage to additional packs. Do NOT attempt to clean pack surfaces yourself!

4.5.3 Head Cleaning (Figure 4-16)

The need for cleaning heads should be determined by inspection and drive usage. Cleaning a clean head serves no useful purpose and exposes the head to possible contamination; therefore, frequency of cleaning must be based on the observed condition of the heads.

1. Clean and polish the heads, using a clean Kimwipe wrapped tightly and smoothly around the plastic paddle. Hold the paddle firmly against the head surface, keeping the paddle flat against the head at all times, and clean with a side-to-side motion.

NOTE:

A clean Kimwipe should be used for each head. The top of the wrapped paddle may be used for the upper head and the bottom for the lower head. However, the wipe should then be replaced with a clean one before beginning on the next head.

2. One to three drops of alcohol may be used; however, this *must* be followed by a polishing or buffing with a clean, dry Kimwipe-wrapped paddle. Use of a greater amount is permissible if the heads are extremely dirty, but *must* be followed by a cleaning with one to three drops of alcohol and then a dry buffing.
3. Reinspect the heads after cleaning to ensure that the residue has been completely removed, and no lint or paper fragments were left.



M 0622

Figure 4-16 Cleaning Heads in Drive

4.6 POWER

4.6.1 Power Conversion

NOTE

Following any frequency conversion, be sure to check power supply voltages both at the transformer primary and secondary windings and at regulator outputs.

4.6.1.1 50-Hz to 60-Hz Conversion – Materials needed are included in the 60-Hz Drive Motor Assembly Kit. The conversion procedure is as follows.

1. Replace the drive motor as described in Paragraph 4.6.6.2 of the *RP05/RP06 Technical Manual*.
2. Replace the drive belt as described in Paragraph 4.6.6.4 of the *RP05/RP06 Technical Manual*.
3. Verify that the Power Conversion Plug Assembly (Figure 4-6) has the phase-to-phase connector installed.

4. Determine the phase-to-phase voltage of the power source, and move power supply leads to appropriate terminals of TB319 on the transformer. (Refer to Figure 4-17.)
5. Refer to Figure 4-17 and move the following wires:

From TB317-1 to TB318-1
From TB317-3 to TB318-3
From TB317-4 to TB318-4
From TB317-6 to TB318-6
From TB317-7 to TB318-7
From TB317-9 to TB318-9
From TB317-10 to TB318-10
From TB317-12 to TB318-12.

4.6.1.2 60-Hz to 50-Hz Conversion – Materials needed are included in the 50-Hz Drive Motor Assembly Kit. The conversion procedure is as follows.

1. Replace the drive motor as described in Paragraph 4.6.6.2 of the *RP05/RP06 Technical Manual*.
2. Replace the drive belt as described in Paragraph 4.6.6.4 of the *RP05/RP06 Technical Manual*.
3. Determine if the power source is WYE or DELTA configured. Locate the Power Conversion Plug. If the source is DELTA, install the phase-to-phase plug. If the source is WYE, install the phase-to-neutral plug.
4. Determine the phase-to-phase voltage of power source if DELTA configured, or the phase-to-neutral voltage if WYE configured, and move power supply leads to appropriate terminals of TB319 on the transformer. (Refer to Figure 4-17.)
5. Refer to Figure 4-17 and move the following wires:

From TB318-1 to TB317-1
From TB318-3 to TB317-3
From TB318-4 to TB317-4
From TB318-6 to TB317-6
From TB318-7 to TB317-7
From TB318-9 to TB317-9
From TB318-10 to TB317-10
From TB318-12 to TB317-12.

4.6.2 Power Configuration Check

4.6.2.1 60-Hz Drive – The procedure for checking the power configuration is as follows.

1. Verify that the Power Conversion Plug Assembly (Part No. 215766, shown in Figure 4-6) has the phase-to-phase connector installed (P110 in the Memorex *RP05/RP06 677-01 Logic Manual*, EK-RP05M-TM-V01, page ZA100).
2. Determine the phase-to-phase voltage of the power source, and move power supply leads to appropriate terminals of TB319 on the transformer. (Refer to the above logic manual, page ZA100.)

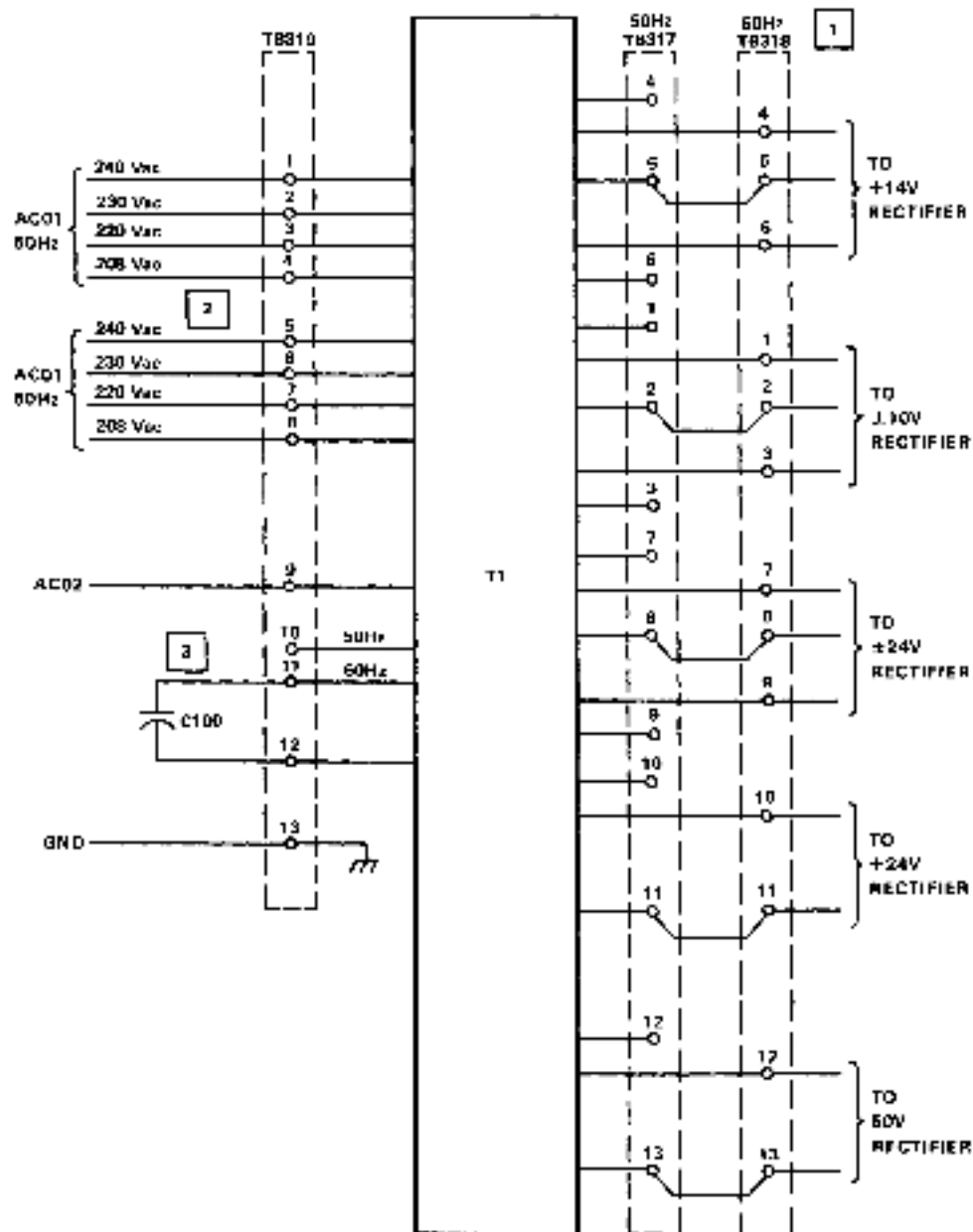

NOTES Unless otherwise specified:

1. Wiring shown for 60Hz. For 50Hz wire connections to corresponding points on T8317.
2. Connect lead to voltage tap closest to Inral supply voltage and at proper frequency.
3. Connect lead to appropriate tap (50Hz or 60Hz).

Refer to RP05/06 Logic Manual for more detail (EK-RP06M-TM-V02).

0P 2009

Figure 4-17 Transformer Primary and Secondary Connections

4.6.2.2 50-Hz Drive – The procedure for checking the power configuration is as follows.

1. Determine if power source is WYE or DELTA configured. Locate the Power Conversion Plug Assembly (Part No. 215766, shown in Figure 4-6). If the source is DELTA, install the phase-to-phase plug. If the source is WYE, install the phase-to-neutral plug (P110 in the above logic manual, page ZA100).
2. Determine the phase-to-phase voltage of power source if DELTA configured, or the phase-to-neutral voltage if WYE configured, and move the power supply leads to appropriate terminals of TB319 on the transformer. (Refer to the above logic manual, page ZD100).

CHAPTER 5

INSTALLING THE RP05/RP06 INTO AN RJP05/RJP06 SUBSYSTEM

5.1 INTRODUCTION

When one or more RP05 (or RP06) is combined with one or more RH11 controller, the combination is designated as an RJP05 (or RJP06) subsystem. System diagram E-SD-RP04-0-1 shows system interconnection, module locations, power wiring, and single-port and dual-port option data. More complete details regarding this type of installation can be found in the *RJP05/RJP06 Moving Head Disk Subsystem Maintenance Manual* (EK-RJP05-MM-001) and the *RP05/RP06 Device Control Logic Maintenance Manual* (EK-RP056-MM-001).

5.2 ELECTRICAL

Power cable connections, Unibus cable connections, and Massbus cable connections are described in the following paragraphs.

5.2.1 Power Cable Connections

Power is distributed to the two hex-height RH11 modules via two power cables that attach to the printed circuit backplane assembly by quick-disconnect tabs. (Refer to the RH11 wired assembly drawing, D-AD-7009397-0-0.) The power cables have Mate-N-Lok connectors on one end to connect to the power distribution panel located above the backplane, and quick-disconnect tabs on the other end to connect to the RH11 backplane assembly. The color codes associated with the power harness connections are as follows.

Harness No. 1 Rows 1-4		Harness No. 2 Rows 5-9	
+5 V	Red	AC LO (+3 V to +5 V)	Yellow
+5 V	Red	DC LO (+3 V to +5 V)	Violet
Gnd	Black	LTC (8 V peak-to-peak ac)	Brown
Gnd	Black	+15 V	Gray
		-15	Blue
		+5 V	Red
		+5 V	Red
		Gnd	Black
		Gnd	Black

CAUTION

Ensure that backplane wires are not damaged when power cables are connected to the backplane. Do not cut AC LO and DC LO wires out of the power harness, as they are used for power fail conditions on the Massbus and on both Unibus A and Unibus B ports.

After power connections have been made, check for power shorts with an ohmmeter. Ensure that all modules are firmly seated in the proper slots (Figure 5-1). Power up the CPU or expander box and measure voltages in accordance with values listed for the preceding color codes. After this is done, turn the power OFF.

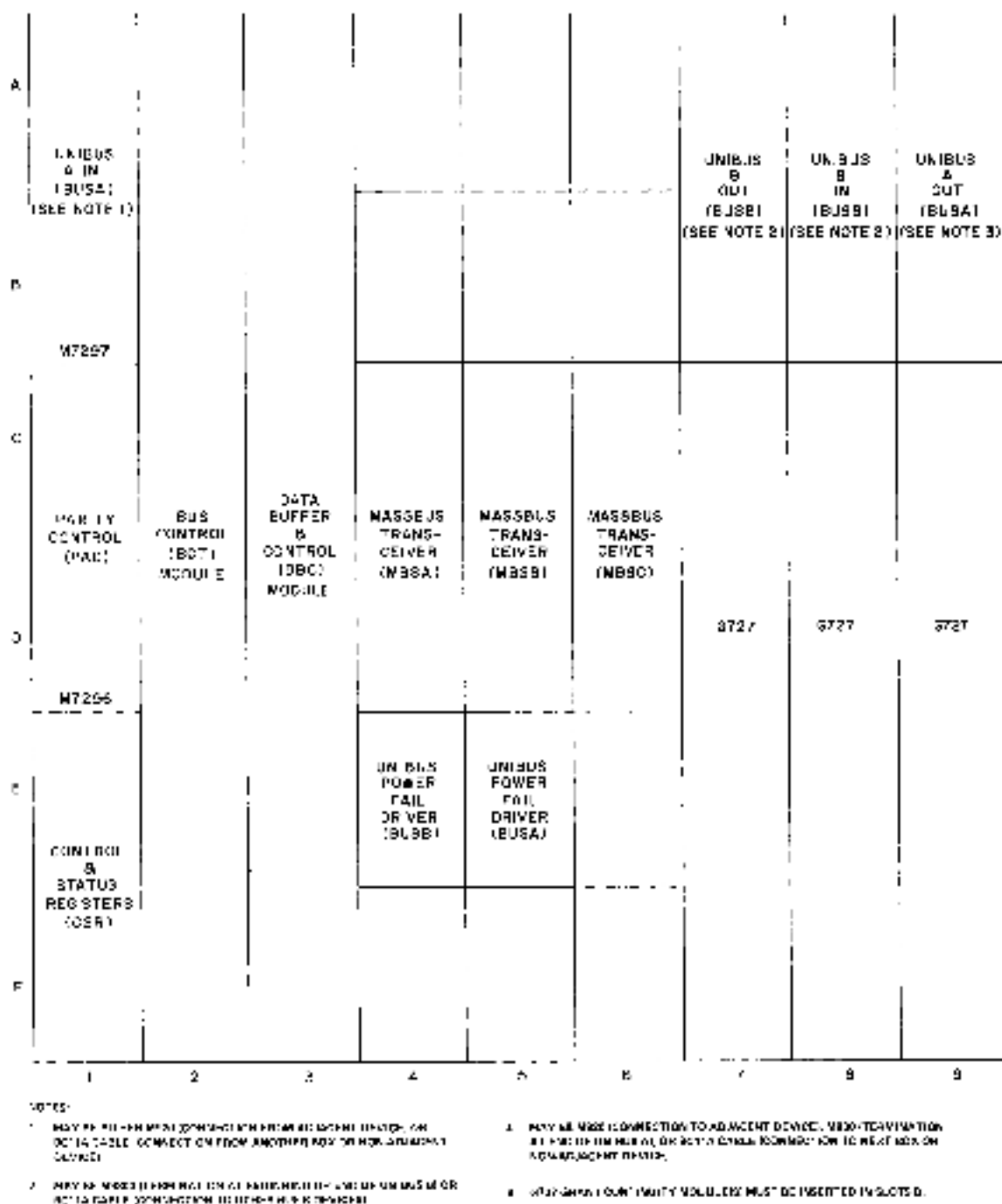

Figure 5-1 RH11 Module Utilization

5.2.2 Unibus Cable Connections

The RH11 is a two-port Unibus device capable of accepting two Unibus cable systems, designated Unibus A and Unibus B.

5.2.2.1 Unibus A Connections - The Unibus A cable slots connect the RH11 to the processor controlling it. The Unibus A cable enters the RH11 via slot A1B1 and connects to the next device via slot A9B9. (Refer to the module utilization drawing, D-MU-RH11-0-01.) Connections to slot A1B1 are made via the BC11A Unibus cable if the RH11 is the first Unibus A device in the mounting box. Otherwise, connection to A1B1 from the preceding device is made by an M920 Unibus Jumper module. If the next device on the Unibus is adjacent, connection is also made by an M920 module; if it is not adjacent, connection is made by a BC11A cable.

NOTE

If the RH11 is the last device on Unibus A, an M930 Terminator module is installed in slot A9B9.

5.2.2.2 Unibus B Connections - Unibus B connections are generally made in systems with multiport memories. When the Unibus B port of the RH11 is not used, an M9300 Terminator module (with jumper W1 cut) should be installed in slot A8B8 to terminate Unibus B signals into the RH11. The second M9300 Terminator module should *not* be used in A7B7 in order to conserve power. If the Unibus B port of the RH11 is used, connections are determined on the basis of whether a processor is connected to Unibus B. These connections are described below.

Processor on Unibus B - If a processor is connected to Unibus B, it is electrically connected at the beginning of the bus. In this case, the M930 Terminator modules supplied with the processor are used for bus termination, and the two M9300 modules supplied with the RH11 are not used.

NOTE

The M9300 Terminator module may be used as a substitute for the M930 Terminator module if the jumpers are selected correctly.

The Unibus B cable connection to the RH11 is made via slot A8B8 with a BC11A cable. Connection from the RH11 to the next device is made via a BC11A cable connected to slot A7B7. If the RH11 is the last device on the bus, the M930 or M9300 module is installed in slot A7B7 instead of the BC11A cable.

No Processor on Unibus B - If no processor is connected to Unibus B, an M9300 Unibus B Terminator module must be selected as an NPR arbitrator. If one RH11 is connected to Unibus B, the RH11 is electrically connected at the beginning of the bus with the M9300 selected to act as an NPR arbitrator. One M9300 Unibus B Terminator module is placed in slot A8B8 of the RH11. Jumper W1 of that module must be cut to enable the arbitration logic. Connection to other devices on Unibus B, such as memory, is made via a BC11A cable connected to slot A7B7. The second M9300 is installed in the last device on Unibus B. Jumper W2 is removed to terminate the Unibus with no processor connected.

NOTE

In this case, an M930 Terminator module can be substituted for the M9300 Unibus B Terminator in the last device slot. If more than one RH11 is installed, the user may have extra M9300 modules as a result of a particular configuration. Figures 5-2, 5-3, and 5-4 show typical Unibus configurations.

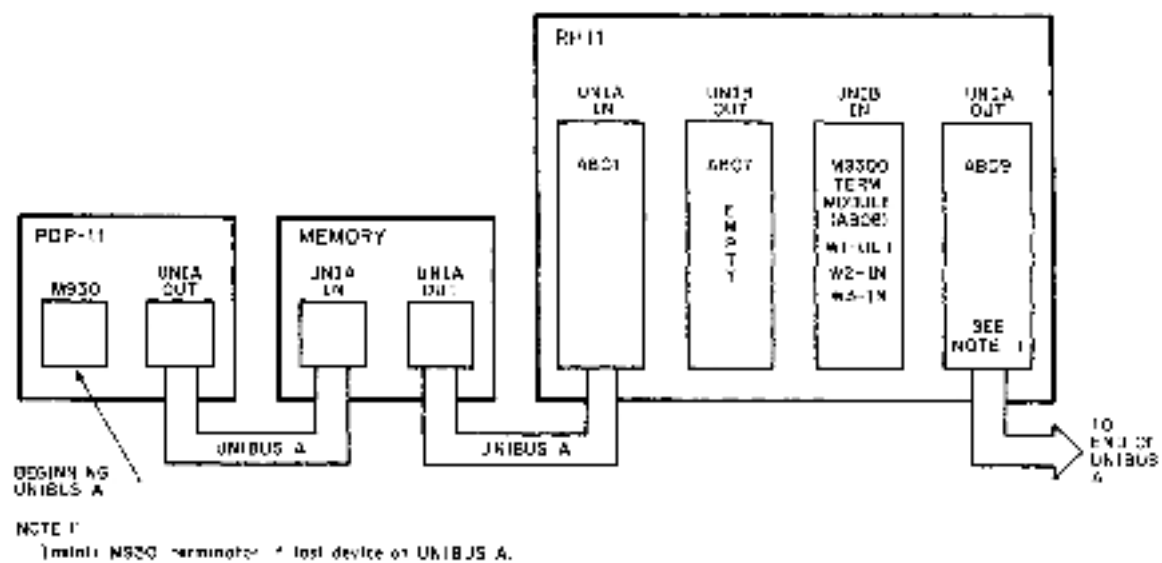

Figure 5-2 Single-Port Unibus Configuration

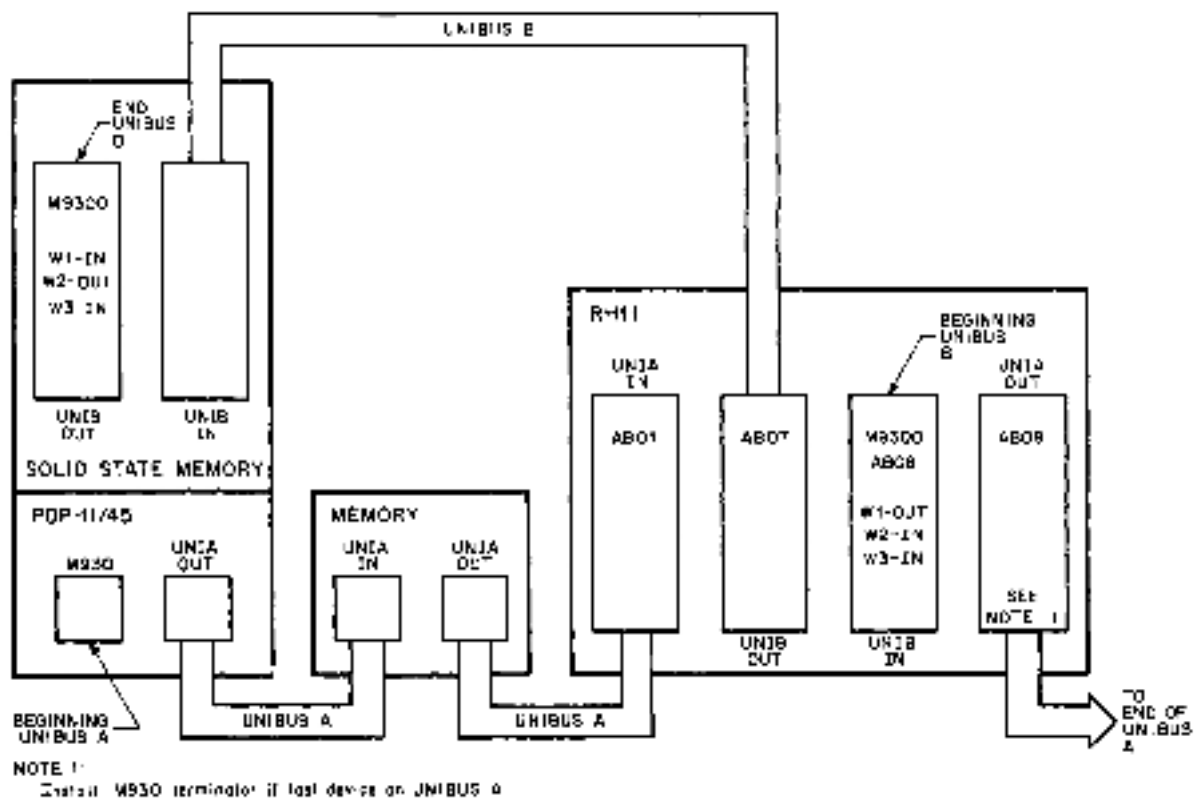
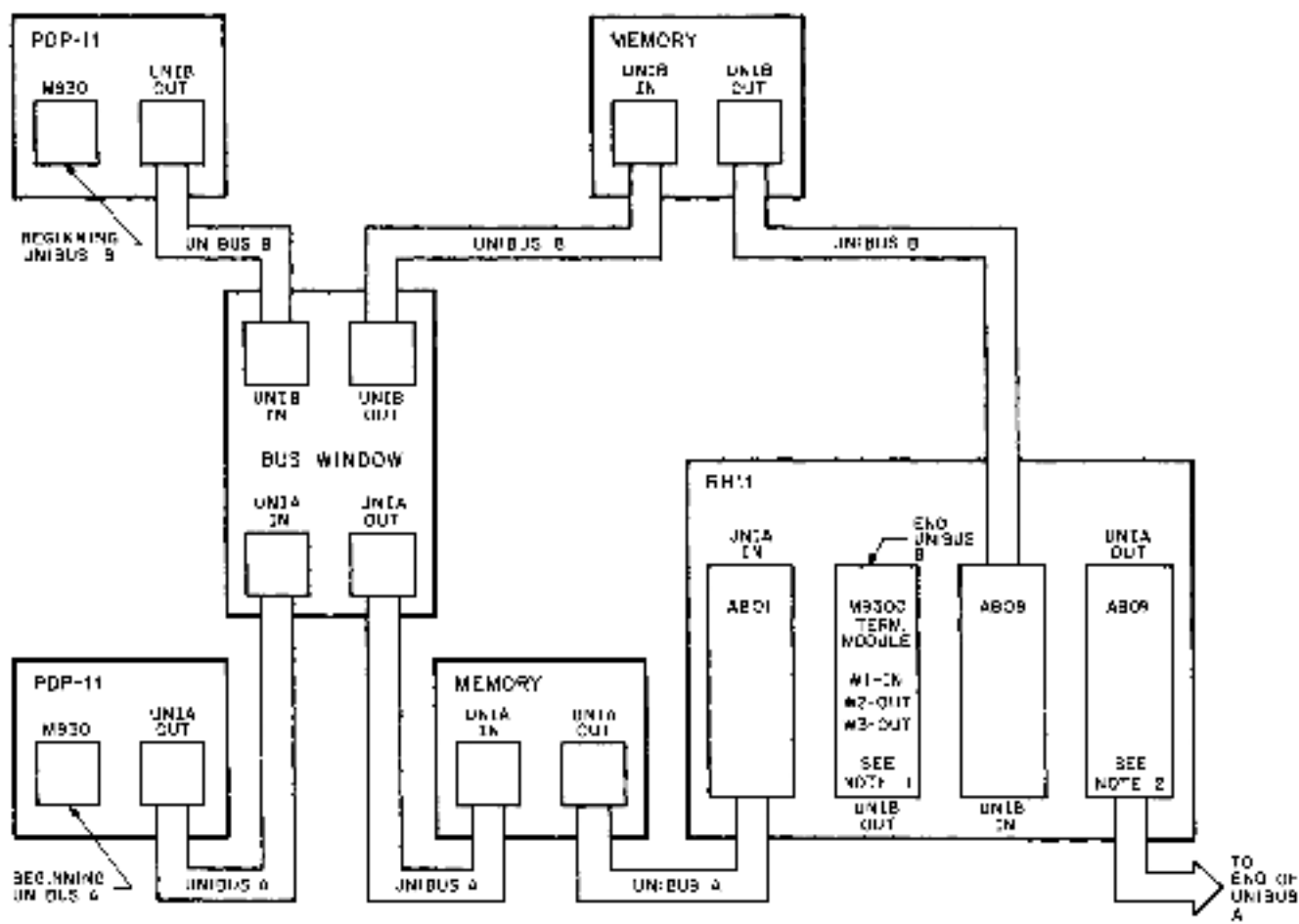

Figure 5-3 Dual-Port Configuration - Memory on Unibus B



NOTES:

1. If this configuration can be replaced by M930.
2. Install M930 terminator if any device on UNIBUS A.

11-2222

Figure 5-4 Dual-Port Configuration Memory and Processor on Unibus B

5.2.3 Massbus Cable Connections

Massbus connections to the RH11 are made via three 2.45-m (8-ft), 40-conductor ribbon cables (BC06R-08). These cables plug into three M5904 transceivers in the RH11, and are designated Massbus cables A, B, and C. These cables should be inserted into the modules with the edge-marking facing the module handles. The other ends of these cables mate to the input/output connector block assembly on the connector panel with the edge-marking facing up (per D-UA-RJP04-A-0). The connections are made as follows.

1. *Massbus Cable A* - From slot C4D4 of the RH11 to the righthand side of the connector block (viewed from the male side, springs at top). The edge-marking should face up.
2. *Massbus Cable B* - From slot C5D5 to the next connector slot, with the edge-marking facing up.
3. *Massbus Cable C* - From slot C6D6 to the next connector slot, with the edge-marking facing up.

To terminate the Massbus, a 7009938 terminator pack assembly should be plugged into the output connector(s) of the last drive (Figure 5-5). The Massbus cable connections to the RH11 are shown in Figure 5-2 and 5-3 for single-port and dual-port systems, respectively.

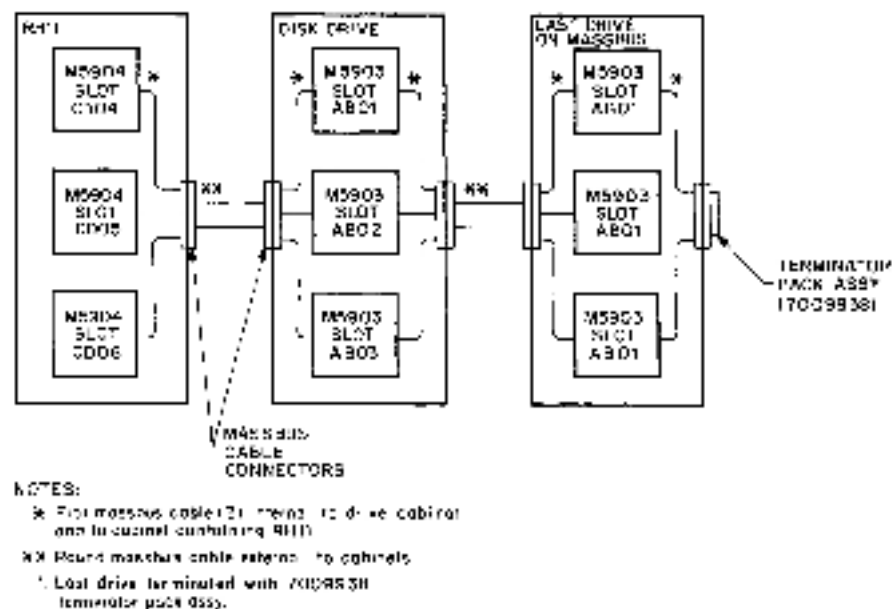

Figure 5-5 Massbus Cable System Configuration

5.2.4 AC LO, DC LO

AC LO and DC LO signals from the RH11 power supply must be connected to the RH11. There should be only one AC LO and one DC LO power fail connection to each Unibus from the power supply of each mounting box. (Otherwise, power fail conditions would latch up due to positive feedback to the power fail logic.) If a device already mounted in the mounting box to be used for the RH11 has AC LO and DC LO connections to a Unibus, remove the M688 Power Fail Drive module for that Unibus from the RH11. The M688 for Unibus A is located in slot E5; the M688 for Unibus B is located in slot F4.

The following is a summary of power fail configuration rules.

1. For each mounting box, there is only one AC LO and DC LO power fail connection to a Unibus from the power supply.
2. Power supply AC LO and DC LO must always be wired to each RH11 via the power harness.
3. Power fail signals may only be disconnected from a Unibus in an RH11 by removing the appropriate M688 Power Fail Driver module.

4. Power supply AC LO and DC LO should be disconnected from all other options mounted in the same box as the RH11 if they do not need those signals for internal operation.

Figures 5-6, 5-7, and 5-8 show three typical power fail configurations that conform to these rules.

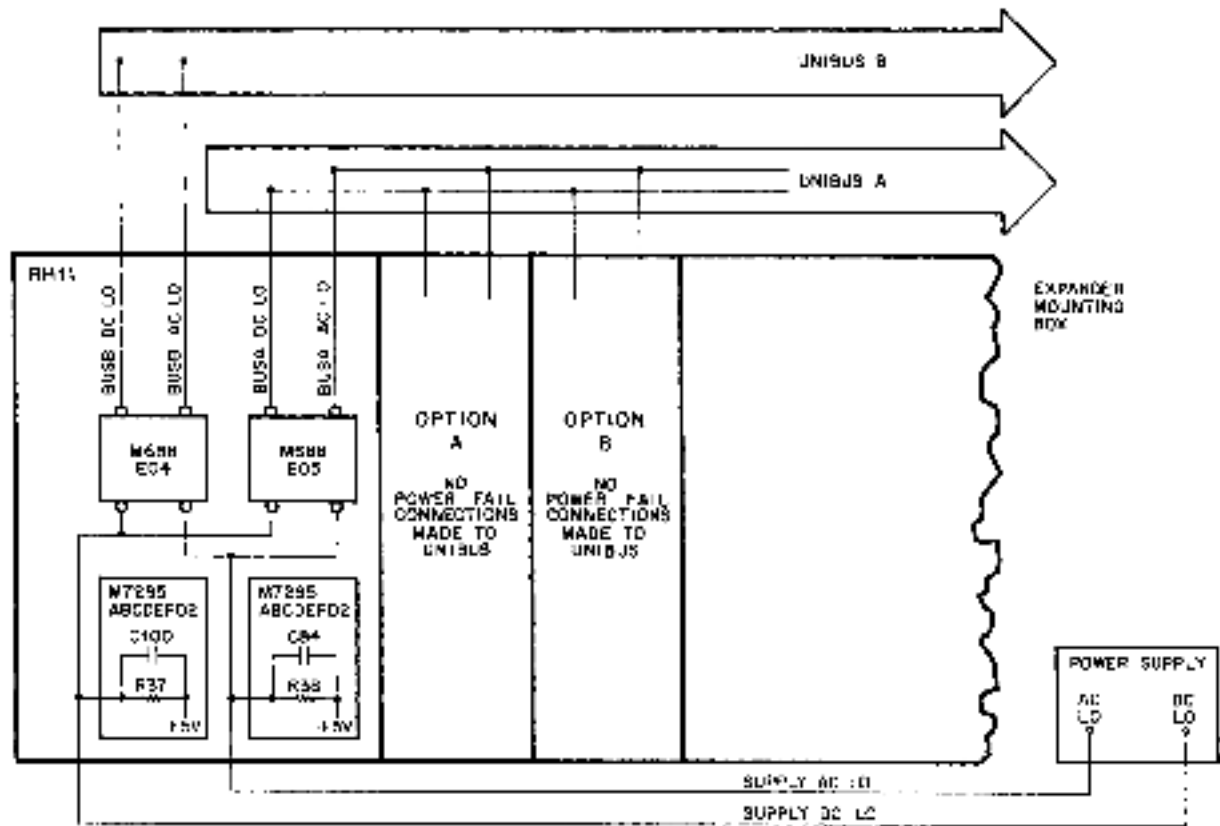

NOTE
See RH11 mounted with other options in
an expander mounting box.

P 2213

Figure 5-6 Typical Power Fail Configuration for RH11 and Options Mounted in Same Expander Box

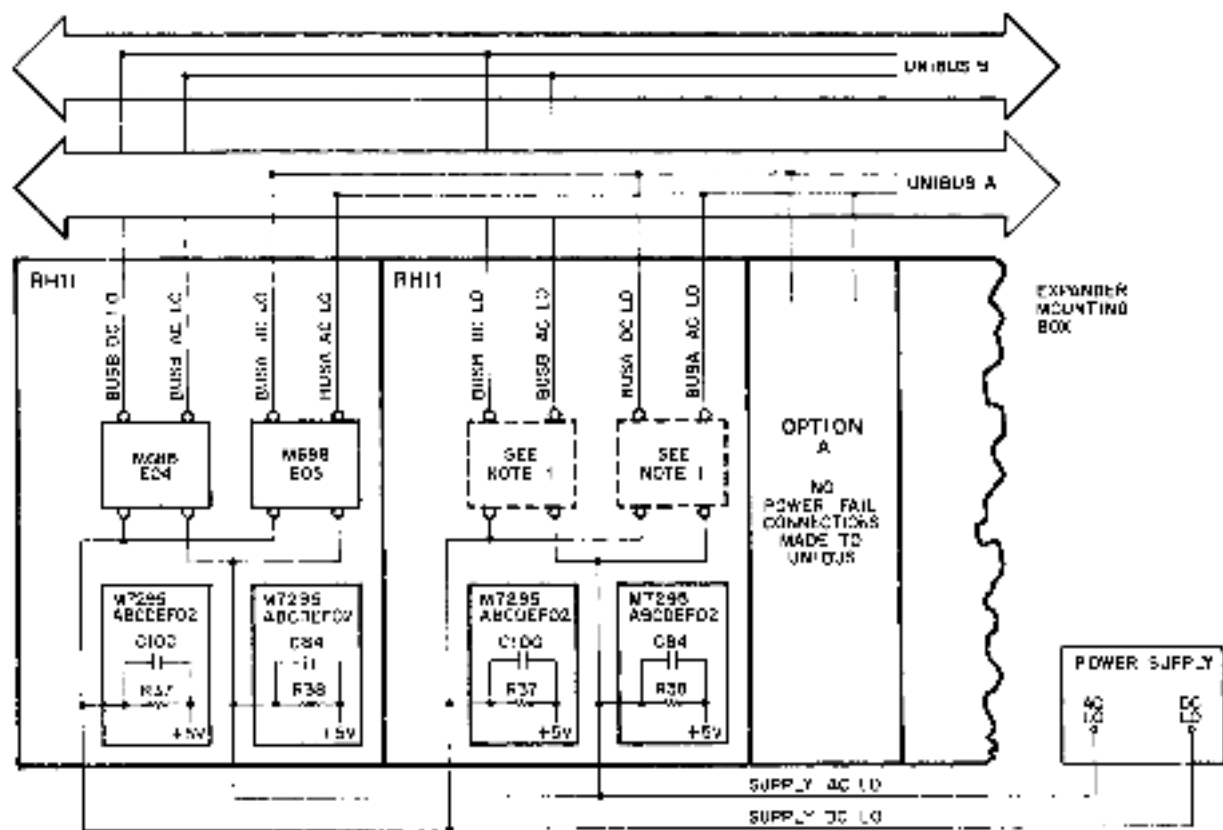

NOTE 1
 Disconnect power fail signals from BUSA by removing M68B in slot E05 & from BUSB by removing M68B in slot E04.

11-2576

Figure 5-7 Typical Power Fail Configuration for Two RH11s Mounted in Same Expander Box

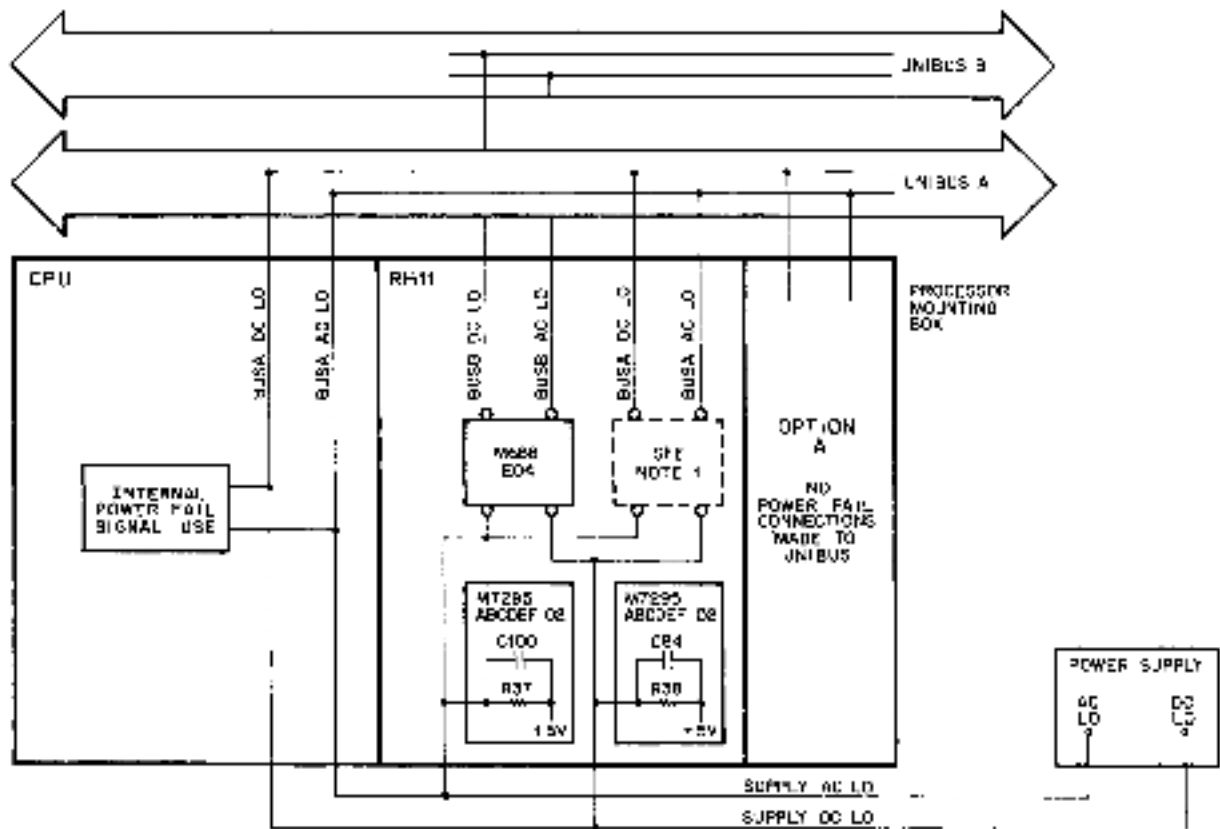

NOTE 1
 Disconnect power fail signals from BUSA by
 removing M688 in unit E04.

5-8*

Figure 5-8 Typical Power Fail Configuration for RH11 and CPU Mounted in Processor Box

5.3 JUMPER CONFIGURATIONS

The following paragraphs describe the various jumper configurations on the BCT, DBC, and CSR modules.

5.3.1 BCT Module (M7295)

The BCT module contains jumpers for register selection, BR level interrupt, NPR latency, vector address, and missed transfer error.

5.3.1.1 Register Selection – The RH11 is capable of responding to 30 possible Unibus addresses, with the exact number dependent on the Massbus device. For the RP05/RP06 Disk Drive, the following jumper configuration should be used (D-CS-M7295-0-1, sheet 2).

Jumper	Address Bit	Jumper In/Out*
W1	12	Out
W2	11	Out
W3	10	Out
W4	9	In
W5	8	Out
W6	7	Out
W7	6	Out
W8	5	In

*Jumper In = Binary 0.

Jumpers W1–W8 select the block of Unibus addresses to which the RH11-RP05/RP06 responds. The standard addressing block assigned is 776700–776746.

The jumpers in E3 (D-CS-M7295-0-1, sheet 2) are selected for the appropriate number of registers (20) in the RJP05/RJP06 subsystem.

Slot	Jumper	Jumper In/Out
E3	1-16	Out
	2-15	Out
	3-14	In
	4-13	In
	5-12(2)	In
	6-11(4)	Out
	7-10(8)	In
	8-9(16)	Out

5.3.1.2 BR Level Interrupt – The priority jumper plug for the RH11 is normally set for the BR5 level. This plug is located in E57 (D-CS-M7295, sheet 7).

5.3.1.3 NPR Latency – Special circuitry is incorporated on the BCT module to improve NPR latency time for devices connected to the Unibus. This circuitry is enabled via jumper W18 (D-CS-M7295-0-1, sheet 7). When the jumper is left in, the NPR latency feature is enabled. Not all PDP-11 processors will work with this special feature.

5.3.1.4 Bus Grant – If there are no small peripheral controllers installed in slots C7–F7, C8–F8, and C9–F9, G727 Grant Continuity modules must be installed in slot D7, D8, or D9. These modules merely continue the Bus Grant signals to the next device on the Unibus.

5.3.1.5 Vector Address Jumpers – The interrupt vector transferred to the processor is jumper-selectable via jumpers W11–W17, representing vector bits 2–8, respectively. The RJP05/06 subsystems are assigned a vector address of 000254, with the following jumper configuration.

Jumper	Vector Bits	Jumper In/Out*
W11	V2	In
W12	V3	In
W13	V4	Out
W14	V5	In
W15	V6	Out
W16	V7	In
W17	V8	Out

*Jumper In = Binary 1.

5.3.1.6 MXF Jumper – Jumper W19 (D-CD-M7295-0-1, sheet 9) is used to disable detection of MXF errors and is used during special maintenance procedures. W19 is normally left in.

5.3.2 DBC Module (M7294)

The DBC module contains jumpers for NPR cycle selection, Unibus parity, and start counter capacities.

5.3.2.1 NPR Cycle Selection Jumpers – Two jumpers select the type of cycle to be implemented when performing NPRs. Jumper E66 (3–14) (D-CS-M7294-0-1, sheet 2) selects the RH11 to perform one memory reference for each NPR request; this jumper is removed in the RJP05/RJP06 subsystem to allow back-to-back memory cycles to occur. Jumper E66 (2–15) takes advantage of dedicated Unibus B systems (those in which the RH11 is used exclusively as a Unibus B master) by allowing the RH11 to transfer complete consecutive blocks of data without giving up the Unibus; to implement this feature, both this jumper and E66 (3–14) must be cut (BUS HOG mode).

5.3.2.2 Unibus Parity Jumpers – The RH11 option can be selected for 16-data-bit transfers (plus two parity bits) or 18-data-bit transfers. Unibus A and Unibus B can each be selected individually via jumpers W1 and W2 (D-CS-M7294-0-1, sheet 8). If left in, jumper W1 allows parity error code detection on Unibus A when the RH11 is performing DATI operations; if W1 is removed, the PA and PB parity lines of Unibus B are used as data bits 16 and 17, respectively. Jumper W2 serves Unibus B in the same manner as W1 serves Unibus A. Both jumpers are normally left in.

5.3.2.3 Start Counter Jumpers – Various Silo capacities are jumper-selectable before a write operation onto the disk drive is started. The jumper selections are listed below (D-CS-M7294-0-1, sheet 9).

Jumper E66, Pins 1–16	Selects full capacity of 64 words
Jumper E66, Pins 5–12	Selects 32 words
Jumper E66, Pins 7–10	Selects 16 words
No Jumper	Selects 1 word

NOTE

Only the jumper representing the desired Silo capacity should be connected. The other jumpers should be removed. For RJP05/RJP06 subsystems, the 64-word jumper (E66, pins 1–16) should be connected.

5.3.3 CSR Module (M7296)

The CSR module contains a jumper (W1 on D-CS-M7296-0-1, sheet 2) to allow for Unibus A selection only. This jumper overrides the ability of the program to select Unibus B data transfers. The jumper is normally removed.

5.4 RH11 INSTALLATION PROCEDURE

This procedure should be performed twice when installing RJP05/RJP06-BA or -BB subsystems.

1. Visually check the RH11 backplane assembly for bent pins by sighting along the rows of pins from two directions. Also check for pinched or broken wires.
2. Check the backplane for the current wire-wrap revision and remove and check all RH11 modules for current ECO revisions.
3. Mount the RH11 backplane assembly in the appropriate mounting box using four 8/32-inch X 1-inch Allen-head screws.
4. Connect the two power harnesses to the RH11 as described in Paragraph 5.2.1. Ensure that Mate-N-Lok connectors are seated firmly in the power distribution panel located on the chassis above the backplane.
5. Check the RH11 backplane again for bent pins and shorted wires.
6. Power-up the CPU or expander box and check all voltages, then power-down.
7. Check that the wires supplying AC LO and DC LO signals from the power supply are connected to the RH11, as described in Paragraph 5.2.4.
8. Verify and/or select the jumper configurations in the RH11 according to Paragraph 5.3 and drawing D-CS-M7295-0-1.
9. Verify that all modules are placed according to the RH11 module utilization list (D-MU-RH11-0-1).
10. Verify that Unibus cable connections are made according to Paragraph 5.2.2.
11. Mount an input/output connector block assembly (7009861) to a connector panel (7412379) with four 4/40-inch X 5-inch screws (9008042-8).
12. Verify that two pressure-sensitive labels are applied to the connector panel for each input/output connector block assembly (E-UA-RJP05-A-0 or E-UA-RJP06-A-0). Label 1 is applied above the input/output connector block assembly, and Label 2 is applied below it.

Controller					
A	B	1	2	3	4

Label 1

The second line of Label 1 must be marked so that only one letter and one number are visible. The single controller (RH11) used in an RJP05/06-AA or -AB subsystem, as well as the first controller used in an RJP05/06-BA or -BB subsystem, is referred to as controller A. If it is the first subsystem using the connector panel, it is designated controller A1 (etc., up to controller A4). The second controller in an RJP05/06-BA or -BB subsystem is designated as controller BX, where X is the same subsystem number as the associated controller A.

Example: Two RH11 controllers are mounted in the same cabinet, one for each of two RJP05/06-AA subsystems. Each RH11 uses one input/output connector block on the connector panel; the first is called controller A1, the second is A2. Later, an RJP05/06-BA subsystem is installed with its two RH11 controllers mounted in the same cabinet. The remaining two slots on the connector panel are used, with one being labeled A3 and the other B3.

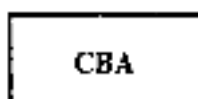

Label 2

This label simply shows the relative positions of the flat Massbus cables A, B, and C.

13. Mount the connector panel at the bottom rear of the cabinet containing the RH11, using four 10/32-inch Tinnerman nuts (Part No. 9006586) and four 10/32-inch \times 0.38-inch Truss-head screws (Part No. 9006071-3). (Refer to D-UA-RJP05-A-0 or D-UA-RJP06-A-0.)
14. Verify that Massbus cable connections are according to Paragraph 5.2.3.
15. Clean the air filters at the top of the mounting cabinet, if necessary.
16. Check mounting cabinet fans for proper operation.

CHAPTER 6

RJP05/RJP06 FIELD ACCEPTANCE PROCEDURES AND DIAGNOSTICS

6.1 INTRODUCTION

Field acceptance testing is intended to demonstrate performance of the RP05/RP06 Disk Drive and/or the RJP05/RJP06 subsystem to the customer prior to his acceptance.

6.2 ERROR DEFINITIONS/RATES

The RP05/RP06 contains three registers to display the various error conditions possible. Error register 1 (RHER 1) indicates the operational error related to command and control; error registers 2 and 3 (RHER 2, RHER 3) indicate drive error conditions. Two bits of RHER 3 (SKI and OCY1) indicate seek errors and are used to calculate the seek error rate (Paragraph 6.2.4). Four bits of RHER 1 (HCRC, HCE, ECH, and DCK, which may include DTE and FER) indicate data errors; the remaining bits of RHER 1 indicate command and control errors. Table 6-1 lists indications of the various error types and their explanations.

6.2.1 Hard Errors

Any failure to read data correctly after a complete recovery sequence with ECC enabled constitutes an irrecoverable, or hard, error. (A complete recovery sequence consists of 28 retries, 16 at the nominal head position, and 2 each at selected offsets; 10 μm , 20.3 μm , and 30.4 μm (400, 800, and 1200 microinches) for the RP05, and 5 μm , 10 μm , and 15.2 μm (200, 400, and 600 microinches) for the RP06. Errors that are not ECC-correctable include bursts greater than 11 bits in length and isolated dropped bits (separated by more than 11 bits) within a sector. The allowable error rate for hard errors is one error per 10^7 bits read.

Table 6-1 RP05/RP06 Error Conditions

Bit	Bit Set Register	Error Type	Explanation
HCE HCRC	RHER 1 RHER 1	Soft	Sector Count Field/Desired. Sector Compare fails due to CRC failure.
HCRC	RHER 1	Soft	Sector Count Field matches desired sector field but there is CRC error.
HCRC FER	RHER 1 RHER 1	Soft	Format bit in first header word incorrect. NOTE FER without HCRC during an operation that reads the header indicates wrong format pack mounted.
DCK	RHER 1	Soft	Error detected during read operation by examination of ECC bytes; correctable by retry sequence.
DCK ECH	RHER 1 RHER 1	Hard	Error detected which is ECC uncorrectable through 28 retry sequence (16 retries at nominal head position and 12 with head offset).
SKI	RHER 2	Seek	1. Seek operation fails to complete within 85 ms of initiation. 2. Recalibration operation fails to complete within 500 ms of initiation. 3. Offset or return-to-centerline operations fail to complete within 10 ms of initiation.
SKI OCYL	RHER 3 RHER 3	Seek	Positioner has drifted off cylinder subsequent to completion of positioning operation.
HCE	RHER 1	Seek	Sector Count Field (RHLA) does not match Desired Sector Field (RHDST) and there is not a CRC error. This error is not caused by a positioner failure; It is due to a DCL failure. Therefore, HCE alone indicates an RP05/RP06 seek error and not a 677-51 or 677-01 drive seek failure.

6.2.2 Soft Errors

Any failure to read data correctly on the first try that is then read successfully during a recovery sequence constitutes a recoverable, or soft, error. (Refer to Paragraph 6.2.1 for definition of a complete recovery sequence.) The allowable error rate for soft errors is one error per 10^9 bits read.

6.2.3 Pack-Attributable Errors

An error caused by imperfections in the recording surface is regarded as pack-attributable, or media-dependent. If the imperfection is less than 11 bits long, it is ECC-correctable and will appear as a soft error; if more than 11 bits long, it will appear as a hard error. On a given pack, pack-attributable errors will always appear at the same cylinder, sector, and track addresses, with an ECC POS R&G value within 11 bits. The definitions of hard and soft errors in Paragraphs 6.2.1 and 6.2.2 apply only to randomly distributed errors, and do not take into account errors that are pack-attributable. Imperfections in the pack surface may be found by mapping the pack using the formatter program.

6.2.4 Seek Errors

Any positioning operation that is not completed within a specified time (85 ms for Seek commands, 500 ms for Recalibrate commands, and 10 ms for Offset and Return to Centerline commands), or that terminates with the positioner in an incorrect location, constitutes a seek error. The allowable error rate for seek errors is one error per 10^6 seek operations.

6.3 RJP05/RJP06 FIELD ACCEPTANCE TEST

The RJP05/RP06 Field Acceptance Test is designed to demonstrate the performance of the RP05/RP06 Disk Drive when used with an R111 controller.

6.3.1 Operational Checks, Single Controller

When all installation procedures have been completed, the tests described in the following paragraphs should be performed. The total time required to run these tests, in the absence of failures, is 3.5 hours per RP04 or RP05, and 4.7 hours per RP06. The diagnostics are defined in Paragraph 6.4).

RP04/05/06 Diskless Controller Test, Part 1 (Static 1A) – MAINDEC-11-DZRJG

Run Procedure	Run two passes, using default parameters.
Errors Allowed	None
Error Recovery Procedure	Correct problem and restart acceptance on failing drive.
Approximate Run Time	5 minutes/drive

RP04/05/06 Diskless Controller Test, Part 2 (Static 1B) – MAINDEC-11-DZRJH

Run Procedure	Run two passes, using default parameters.
Error Allowed	None
Error Recover Procedure	Correct problem and restart acceptance on failing drive.
Approximate Run Time	10 minutes/drive

RP04/05/06 Functional Controller Test, Part 1 (Static 2A) – MAINDEC-11-DZRJI

Run Procedure	Run two passes, using default parameters.
Errors Allowed	Only pack-attributable errors
Error Recovery Procedure	Correct problem and restart acceptance on failing drive.
Approximate Run Time	5 minutes/drive

RP04/05/06 Functional Controller Test, Part 2 (Static 2B) – MAINDEC-11-DZRJJ

Run Procedure	Run two passes, using default parameters.
Errors Allowed	Only pack-attributable errors
Error Recovery Procedure	Correct problem and restart acceptance on failing drive.
Approximate Run Time	5 minutes/drive

Format Program – MAINDEC-11-DZRJB

Run Procedure	Run according to Table 6-2.
Errors Allowed	Pack-attributable errors only
Error Recovery Procedure	Correct problem and restart acceptance on failing drive.
Approximate Run Time	8 minutes/RP05; 16 minutes/RP06.

RP04/05/06 Mechanical and Read/Write Test – MAINDEC-11-DZRJA

Run Procedure	One pass of all tests, using default parameters. Ten passes of tests 0 through 6.
Errors Allowed	Pack-attributable errors only. (Use same pack as Format Program.)
Error Recovery Procedure	Correct problem and restart acceptance on failing drive.
Approximate Run Time	1 hour, 15 minutes/RP05; 2 hours, 30 minutes/RP06

RP04/05/06 Multidrive Exerciser – MAINDEC-11-DZRJD

Run Procedure	Runs all drives, using default parameters until 6.25×10^7 words have been transferred on all drives
Errors Allowed	One soft error that is not pack-attributable. (Use same pack as Format Program.)
Error Recovery Procedure	Drop failing drive from test. Continue test on remaining drives. Correct problem and restart acceptance on failing drive.
Approximate Run Time	1 hour, 30 minutes/drive

DEC/X11

Run Procedure Run configured for system with default parameters for one hour.

Errors Allowed Two system soft errors that are not pack-attributable. (Use same pack as Format Program.) Data late errors (DLT) are to be expected on heavily-loaded systems and, as such, should not be considered as errors.

Error Recovery Procedure Drop failing drive and continue test on remaining drives. Correct problem and restart acceptance on failing drive.

Table 6-2 Format (MAINDEC-11-DZRJB) Run Procedure

DRV 0	DRV 1	DRV 2	DRV 3	DRV 4	DRV 5	DRV 6	DRV 7	
Default Option (1)	Write Check (1)	Write Check (1)	Write Check (1)	Write Check (1)	Write Check (1)	Write Check (1)	Write Check (1)	
Write Check (1)	Default Option (2)	Write Check (2)	Write Check (2)	Write Check (2)	Write Check (2)	Write Check (2)	Write Check (2)	
	Write Check (2)	Default Option (3)	Write Check (3)	Write Check (3)	Write Check (3)	Write Check (3)	Write Check (3)	
		Write Check (3)	Default Option (4)	Write Check (4)	Write Check (4)	Write Check (4)	Write Check (4)	
			Write Check (4)	Default Option (5)	Write Check (5)	Write Check (5)	Write Check (5)	Write Check (5)
				Write Check (5)	Default Option (6)	Write Check (6)	Write Check (6)	Write Check (6)
						Write Check (6)	Default Option (7)	Write Check (7)
							Write Check (7)	Default Option (8)

To avoid compatibility problems:

1. Use the same CE pack for all drives that will have packs.
2. Format all scratch packs on the same drive.
3. Isolate compatibility problems using Table 6-2.

6.3.2 Operational Checks, Dual Controller

When all installation procedures have been completed, the tests described in the following paragraphs should be performed. The total time required to run these tests, in the absence of failures, is 4.5 hours per RP05 and 5.5 hours per RP06. The diagnostics are defined in Paragraph 6.4.

RP04/05/06 Diskless Controller Test, Part 1 (Static 1A) – MAINDEC-11-DZRJG

Run Procedure	Run two passes, using default parameters (both ports).
Errors Allowed	None
Error Recovery Procedure	Correct problem and restart acceptance on failing drive.
Approximate Run Time	5 minutes/drive/port

RP04/05/06 Diskless Controller Test, Part 2 (Static 1B) – MAINDEC-11-DZRJH

Run Procedure	Run two passes, using default parameters (both ports).
Errors Allowed	None
Error Recovery Procedure	Correct problem and restart acceptance on failing drive.
Approximate Run Time	10 minutes/drive/port

RP04/RP05/RP06 Functional Controller Test, Part 1 (Static 2A) – MAINDEC-11-DZRJI

Run Procedure	Run two passes, using default parameters (both ports).
Error Allowed	Only pack-attributable errors
Error Recovery Procedure	Correct problem and restart acceptance on failing drive.
Approximate Run Time	5 minutes/drive/port

RP04/05/06 Functional Controller Test, Part 2 (Static 2B) – MAINDEC-11-DZRJJ

Run Procedure	Run two passes, using default parameters (both ports).
Errors Allowed	Only pack-attributable errors
Error Recovery Procedure	Correct problem and restart acceptance on failing drive.
Approximate Run Time	5 minutes/drive/port

Dual Controller Logic Test, Part 1 – MAINDEC-11-DZRJE

Run Procedure	Install dual controller option test cable (Part No. 7010507-02). Run two passes, using default parameters.
Errors Allowed	Pack-attributable errors only
Error Recovery Procedures	Correct problem and restart acceptance on failing drive.
Approximate Run Time	5 minutes/drive

Dual Controller Logic Test, Part 2 MAINDEC-11-DZRJF

Run Procedure	Install dual controller option test cable (Part No. 7010507-02). Run one pass, using default parameters.
Errors Allowed	None
Error Recovery Procedure	Correct problem and restart acceptance on failing drive.
Approximate Run Time	5 minutes/drive

Format Program - MAINDEC-11-DZRJB

Run Procedure	Run according to Table 6-2 (one port only).
Errors Allowed	Pack-attributable errors only
Error Recovery Procedure	Correct problem and restart acceptance on failing drive.
Approximate Run Time	15 minutes/drive

Mechanical R/W Test - MAINDEC-11-DZRJA

Run Procedure	One pass of all tests, using default parameters (one port only). Ten passes of tests 0 through 6 (one port only).
Errors Allowed	Pack-attributable errors only. (Use same pack as Format Program.)
Error Recovery Procedure	Correct problem and restart acceptance on failing drive.
Approximate Run Time	1 hour, 15 minutes/drive/port/RP05; 2 hours, 30 minutes/drive/port/RP06.

RP04/05/06 Multidrive Exerciser - MAINDEC-11-DZRJD

Run Procedure	Runs all drives, using default parameters until 6.25×10^7 words have been transferred on all drives. (Run both ports simultaneously.)
Errors Allowed	One soft error that is not pack-attributable. (Use same pack as Format Program.)
Error Recovery Procedure	Drop failing drive from test. Continue test on remaining drives. Correct problem and restart acceptance on failing drive.
Approximate Run Time	2 hours/drive

DEC/X11

Run Procedure	Run configured for system with default parameters for one (both ports).
Errors Allowed	Two system soft errors that are not pack-attributable. (Use same pack as Format Program.) Data late errors (DLT) are to be expected on heavily-loaded systems and, as such, should not be considered as errors.
Error Recovery Procedure	Drop failing drive and continue test on remaining drives. Correct problem and restart acceptance on failing drive.

6.4 DIAGNOSTIC MAINTENANCE

The diagnostic programs described herein are employed with the RJP05/06 subsystems. The following diagnostics are briefly described. Refer to the applicable diagnostic operating procedures for detailed information.

Test Programs

MAINDEC-11-DZRJG MAINDEC-11-DZRJH	RP04/05/06 Diskless Controller Test (Parts 1 and 2)
MAINDEC-11-DZRJI MAINDEC-11-DZRJJ	RP04/05/06 Functional Controller Test (Parts 1 and 2)
MAINDEC-11-DZRJE MAINDEC-11-DZRJF	RP04/05/06 Dual-Controller Logic Test (Parts 1 and 2)
MAINDEC-11-DZRJA	RP04/05/06 Mechanical and Read/Write Test

System Exerciser Program

MAINDEC-11-DZRJD	RP04/05/06 Multidrive Exerciser
------------------	---------------------------------

Utility Programs

MAINDEC-11-DZEJB	RP04/05/06 Formatter Program
MAINDEC-11-DZRJC	RP04/05/06 Head Alignment Verification Program

6.4.1 MAINDEC-11-DZRJG and MAINDEC-11-DZRJH - RP04/05/06 Diskless Controller Test

This program tests the RHH and the DCL portion of the drive. The DCL is the device control logic used to make the RP05/06 Massbus compatible and must be plugged into the MDLI, or appropriately terminated. The program does not use the disk surface or any signals from the MDLI. The MDLI is the mass device level interface which connects the DCL to the drive assembly.

If the disk is powered up, it must be in the Heads Unloaded position. After a successful run (with no errors) of this diagnostic, it can be ascertained that the DCL logic that processes the data is working properly. The logic that handles the mechanical commands is not tested in this diagnostic. All data commands use the Maintenance register in the Wraparound mode.

6.4.2 MAINDEC-11-DZRJI and MAINDEC-11-DZRJJ – RP04/05/06 Functional Controller Test

The diagnostic tests the DCL portion of the drive. It exercises the disk surface and the mechanical of the drive to prove proper operation of the subsystem. To run the diagnostic, a disk pack with no vital information written on it is essential. The disk pack need not be formatted.

After a successful run of this diagnostic (with no errors), it can be concluded that the RP05/06 subsystem is functional. Extended drive testing, timing and subsystem interaction is left to other diagnostics. The RP04/05/06 Diskless Controller Test (MAINDEC-11-DZRJG and MAINDEC-11-DZRJH) must have been run successfully before the Functional Controller Test diagnostics can be run.

6.4.3 MAINDEC-11-DZRJE and MAINDEC-11-DZRJF – RP04/05/06 Dual-Controller Logic Test (Parts 1 and 2)

This program checks the dual-controller logic in the DCL portion of the RP05/06 and requires a special adapter cable.

6.4.4 MAINDEC-11-DZRJA – RP04/05/06 Mechanical and Read/Write Test

This program contains 19 tests numbered 0 through 22.* Tests 0 through 6 use a Read Header and Data command to read the cylinder, track, and sector information from the header; the tests then check the information for validity, ensuring that the seek operation functions properly. Tests 7 through 12 measure the rotational speed, the one-cylinder seek, the average seek, and the maximum seek times to ensure that they are all within the specified tolerances. Tests 13 and 14 ensure that the sector and track addressing circuitry is working properly. Test 15 ensures that the data storage and retrieval capabilities are operative. Test 16 is used to stress and check the read/write and servo systems. Test 17 performs all possible seek combinations and verifies that the cylinder difference calculation is correct for all possible combinations of cylinders. Test 20 verifies that the drive's positioner is not drifting off cylinder after the on cylinder indication has been set. Test 21 performs a series of random seeks with the position verified immediately after the seek has completed.

The program starts by identifying itself and determining that all drives are available for testing. All drives are then tested beginning with the lowest numerical drive and proceeding in sequential order. One pass (tests 0 through 15, 20, and 21) is performed on each drive before moving to the next drive in sequence. The drive to be tested will be typed at the beginning of each pass. At the completion of each pass, an end-of-pass message will be typed. After testing all drives, an end-of-test message will be typed.

6.4.5 MAINDEC-11-DZRJD – RP04/05/06 Multidrive Exerciser

The Multidrive Exerciser Program exercises one to eight disk drives attached to the same RH11. If two or more disk drives are being exercised, operations on the drives are overlapped. (Other drives are performing seek/search operations while one drive is performing a data transfer or write-check operation.) Operations among the drives are optimized so that a high subsystem data transfer rate or a high positioning operation rate is maintained.

The performance of each drive is monitored by the program. If a drive exceeds a reset number of errors in any of several categories, that drive is automatically deassigned. (The operator may override the automatic deassignment feature.) The program reports performance statistics for each drive being exercised on request from the operator or automatically at an interval determined by the operator.

All data transfer commands are used (i.e., Write Data, Write Header and Data, Read Data, and Read Header and Data) as well as Write-Check Data and Write-Check Header and Data commands. Recalibrate and Read-In Preset commands are used at startup and drive initialization. Recalibrate, Offset, and Return to Centerline commands are used during error processing.

*Test 22 is an RJP04 Subsystem Test and is not applicable to the RJP05/06 subsystems.

Program/operator communications are through the Teletype⁴; program options are selected by Switch register settings and errors are normally reported on the Teletype. However, if a line printer is available, the program will use the printer for error message display.

All commands, data patterns, and data buffer sizes are selected randomly by the program. The addresses (e.g., cylinder, track, and sector) for each operation are also selected randomly.

At the completion of each operation, the program checks the RFI1. The program requires data packs created by the Formatter Program (MAINDEC-11-DZRJB), by the Read/Write and Mechanical Test (MAINDEC-11-DZRJA), or by the Data Pack Generation command of the Exerciser Program.

6.4.6 MAINDEC-11-DZRJB - RP04/05/06 Formatter Program

The Formatter Program is designed to write and verify header and data information on all possible disk pack addresses with the intention of testing the retention of the recording surfaces. The format is maintained on a basis of 411 cylinders (for an RP05; 815 cylinders for an RP06), 19 tracks per cylinder, and 22 sectors per track.

This program formats the disk pack on the assigned drive one track at a time. The data fields are written with the selected pattern. Key words are written with 0s. Each track is verified with a Write-Check command immediately after it is written.

The portion of the pack to be formatted is determined by the first and last cylinder and track addresses, inclusively. A single track is the smallest element that may be formatted.

Write-check errors are reported when they are detected. If an error is detected, the sector must be rewritten and verified correctly two successive times to be considered usable. Sectors that cannot be written correctly twice after an error will be declared unacceptable by the program.

After the last track has been formatted and verified, an additional check is performed. The header of track 0 and sector 0 of each cylinder is read and compared by the software. This check is performed to isolate a possible positioner error that may have occurred during the format operation. Two such cases of positioner malfunction are: failure of the positioner to advance to the next cylinder, and advancement of the positioner past the cylinder desired.

6.4.7 MAINDEC-11-DZRJC - RP04/05/06 Head Alignment Verification Program

This program checks head alignment of the RP05/06 disk drives. For the RP05 drive, the program checks alignment of heads 0 through 18 at cylinder 245 and heads 0 and 18 at cylinders 4 and 400. For the RP06 drive, the program checks alignment of heads 0 through 18 at cylinder 496 and heads 0, 1, 10, 17, and 18 at cylinders 8 and 800. Alignment is then reverified at the basic alignment cylinder (245 for the RP05; 496 for the RP06). The operator will be notified if any head is out of alignment by more than the specified value.

The program requires that the head alignment test box (Perch) be connected to the drive under test and that the alignment disk pack to be mounted. The program provides options which allow the operator to use the head alignment test box to perform head alignment and to exercise the positioner to verify that the heads were tightened properly after alignment.

⁴Teletype is a registered trademark of Teletype Corporation.

CHAPTER 7

INSTALLING THE RP05/RP06 INTO AN RHP05/RHP06 SUBSYSTEM

7.1 INTRODUCTION

When one or more RP05 is combined with one or more RH10 controller, the combination is designated as an RHP05 subsystem. When one or more RP06 is combined with one or more RH10 controller, the combination is designated as an RHP06 subsystem. The Massbus interface and all channel bus, I/O bus, and Massbus operations that apply to the RH10/R504 are described in detail in the *RH10 Massbus Controller Maintenance Manual* and also apply to the RP05/RP06. The drives have 16 Massbus registers; Figure 7-1 shows the formats for all RP05/RP06 Massbus registers in an RHP05/RHP06 subsystem. Refer to drawing D-FD-RH10-0-INST for DATA0 and CON0/CON1 formats.

RP05/RP06 Massbus commands are as follows.

Octal Code	Command
01	No Op
03	Unload
05	Seek
07	Recalibrate
11	Drive Clear
13	Release
15	Offset
17	Return to Centerline
21	Read-in Preset
23	Pack Acknowledge
31	Search
61	Write Data
63	Write Header and Data
71	Read Data
73	Read Header and Data

These command codes may be set in the last two octal digits of the switch panel, and are displayed in the CR FUNCTION CODE lights. Figure 7-2 represents a simplified block diagram showing typical RHP05/RHP06 subsystem cable types and connections.

7.2 ELECTRICAL

Power cable connections and Massbus cable connections are described in the following paragraphs.

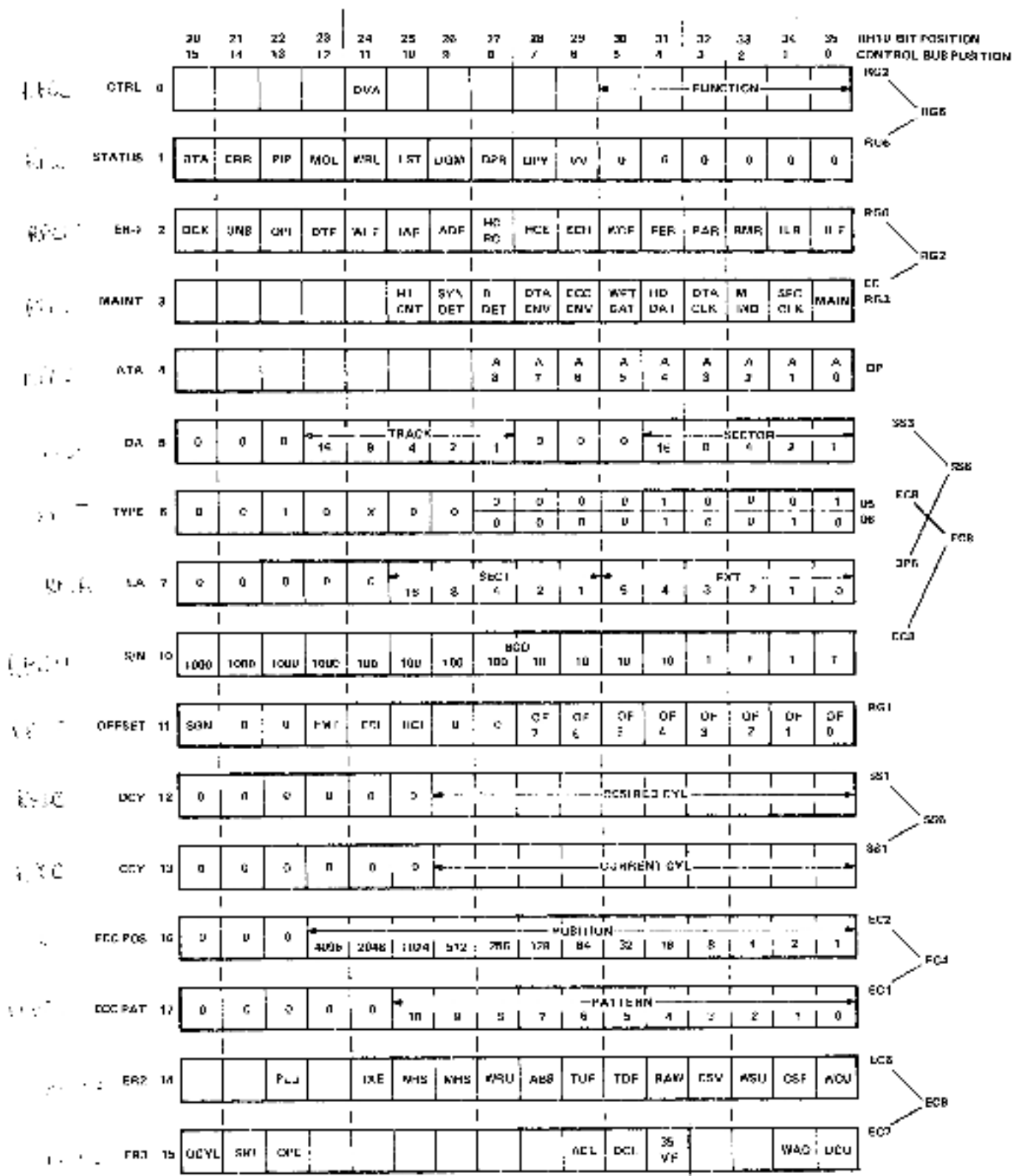
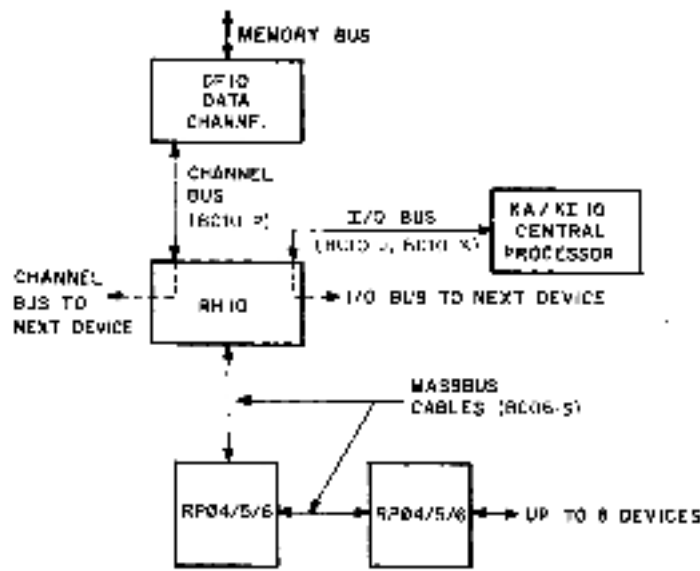

Figure 7-1 RP05/RP06 Register Format (RH10)



SP-2793

Figure 7-2 RH10/DF10/RP04/RP05/RP06 Interconnection Diagram

7.2.1 Power Cable Connections

Power is distributed within an RHP05/06 subsystem by means of the self-contained RH10 power supply and a DEC type-857 power control. The +5 Vdc and -15 Vdc requirements of the system are provided by DEC type-742 power supplies; the +15 Vdc requirement is provided by a DEC type-783 power supply. Power is applied to the subsystem as follows.

1. Insert the drive power plug into the unswitched side of the 861 power control.
2. Connect the incoming remote power cable (3-wire) into J1 of the drive, and the output remote power cable into J2, if applicable.
3. Connect the power sequence into J3 if this is the first drive; otherwise, connect the incoming 4-wire power sequence cable to J3.
4. If this is the last drive, or the only drive, no connection need be made to J4; otherwise, a 4-wire sequence cable is output from J4 to J3 of the next drive. Part numbers are:

70-08288	J1, J2 cable, 3-wire
70-09490	J3 jumper plug, 1st device
70-09491	J3, J4 cable, 4-wire

5. Turn SW1 to REMOTE and turn the circuit breaker ON. When the CPU is turned ON, all drives (if multidrive) will power sequence up, one at a time.
6. Ensure that phasing is correct by noting that the pack spins in a *counterclockwise* direction. If not, reverse the phases in the power box.
7. When preceding steps have been completed, the drive is physically mounted. Refer to the acceptance procedures in Chapter 8.

7.2.2 Massbus Cable Connections

The RP05/RP06 connects to the RH10 by means of a round Massbus cable assembly (BC06S). Flat cable is used within the DCL from the round cable transition connector up to the M5903 standard Massbus transceiver modules in the DCL. Two round cable connection paths exist; one for input from the previous RH10 or RP05/RP06 and one for output to the next device. If another drive is to follow, route a BC06S round Massbus cable assembly out through the rear of the drive through the right cable clamp and into the next drive. Terminate the last drive in the subsystem by a termination block (70-09938), which is installed via a zero-insertion-force connector to the final round cable connector block. Be sure that W2 of terminator board "C" is the only jumper cut, as this enables Massfail.

NOTE

CBI may be OFF in the terminating drive, yet the Massbus will operate.

7.3 RH10 MAINTENANCE PANEL

The RH10 contains a maintenance panel that can be useful for off-line troubleshooting of an initial installation before running dedicated diagnostic programs. Most cable and DCL problems can be found and repaired in this manner. The following examples show how the maintenance panel can be used to check the RP05/RP06 configuration, if the RH10 but not the CPU, is available. Run MD-10-DIDRPK (RP06) or MD-10-DDRPJ (RP05) for a thorough check of cables and drive system, if the CPU is available.

Example 1 - Initial Hookup

1. Place the LOCAL/REMOTE switch to LOCAL, with all other switches OFF.
2. Start drive(s) and ascertain that the CONTROLLER SELECT switch points to the correct port. Wait for READY to come ON.
3. Deposit 01000N000000 in the switches (with N the number of the drive to be tested). Read Register 1 (DRSR), which is the Drive Status register.
4. Press CLEAR, then press START.
5. The DIB register data should be 010600 [starting with bit 0 as the first and total octal digit (Figure 7-1)]. If the DIB register data is not correct, check the DIB CBT0 light. If this is ON, the drive did not recognize the command. In any case, the cables and drives in the chain are suspect. If problems exist, power down the drives (by setting CBI to OFF) to eliminate DCL faults and investigate cable/transceiver problems using one drive.

NOTE

The terminators do not require power to operate.

6. If the response was correct, deposit 00400N000021 in the switches. This is a Read-In Preset command.
7. Press CLEAR, then press START.
8. Repeat steps 3 and 4.
9. The DIB Register Data should be 010700. The VOLUME VALID bit is now set.
10. If the data is not correct, set the RECYCLE switch to ON and repeat steps 6 and 7. (Dynamic logic cannot be observed with the oscilloscope.)

Example 2 - Read Data

1. Execute steps 1-4 of Example 1.
2. Deposit 40400N000071 (read data command) in the switches.
3. Press CLEAR, then press START.
4. The indicator panel should show both DONE and NOT BUSY to be ON. DR EXC should be OFF, and DBT0 should not be set. RUN should be OFF, and FIN EN should be ON. DH10 indicates that the DCL failed to respond to the command. If DBT0 is set, go to Example 3 (Recycle Read) to set up an oscilloscope loop. CR CBT0 should be OFF.
5. If DR EXC is set, proceed with the subsequent steps.
6. Deposit 020000N000000 in the switch panel.
7. Press START; do *not* press CLEAR.
8. The contents of Error Register 1 are now displayed. Analyze this data, referring to Figure 7-1.
9. Repeat steps 6-8, using 14 and then 15 as the first two digits, to read Error Registers 2 and 3.

Example 3 - Recycle Read

1. Place the LOCAL/REMOTE switch in LOCAL, with all other switches OFF.
2. Deposit 00400N000021 in the switches.
3. Press CLEAR, then press START.
4. Deposit 01000N000000 in the switches.
5. Press START.
6. Check the DIB Register Data for 010700. (Steps 4, 5, and 6 are for continuity only.)
7. Deposit 05400N000000 in the switches. This is a set to zero of the track and sector address. When recycling, this DIB command is reexecuted following every read.
8. Press START; do *not* press CLEAR.
9. Deposit 40400N000071 in the switches.
10. Set RECYCLE to ON, and press START. The drive will now continually read cylinder, track, sector 0, and can be examined with an oscilloscope. If the entire disk is to be read, omit steps 7 and 8, and the RH10 will automatically move through the entire disk.

Example 4 - Write Data

1. Place the LOCAL/REMOTE switch in LOCAL, with all other switches OFF.
2. Deposit 00400N000021 in the switches.
3. Press CLEAR, then press START.
4. Deposit 40400N000061 in the switches.
5. Press START.
6. The indicator panel should show both DONE and NOT BUSY as being ON. DR EXC should be OFF, and DHT0 should not be set. Debug in accordance with Examples 2 and 3, but use the Write Function code (61) where applicable. RUN should be OFF, and FIN EN should be ON.
7. The data in the Data Buffer lights was written onto the drive (zeros, in this case).
8. To set a data pattern into the Data Buffer for writing, set the switches to 50400NPPPPPP (where P is the pattern).
9. Press START, and repeat steps 4 and 5.

NOTE

Do *not* press CLEAR; this will erase the error.

7.4 VISUAL INSPECTION

Before the acceptance testing is performed, the following visual inspections should be made.

1. Verify that all modules are configured according to the RP05/RP06 Module Utilization List.
2. Ensure that all modules are firmly seated in the system backplane assembly.
3. Inspect the backplane wiring for broken wires or damaged pins; repair or replace as needed.
4. Ensure that the power cable is firmly attached to the system backplane assembly (RP05/RP06).
5. Clean the air filters at the top of the cabinet, if necessary.
6. Ensure that all round Massbus cables are properly terminated and firmly seated, and that the bus is terminated. Inspect the DCL to verify that all flat cables are firmly seated.
7. Check the cabinet fans for proper operation.

CHAPTER 8

RHP05/RHP06 FIELD ACCEPTANCE PROCEDURES AND DIAGNOSTICS

8.1 INTRODUCTION

Field acceptance testing is intended to demonstrate performance of the RP05/RP06 Disk Drive and/or the RHP05/RHP06 subsystem to the customer prior to his acceptance.

8.2 ERROR DEFINITIONS/RATES

The RP05/RP06 contains three registers to display the various error conditions possible. Error register 1 (RHER 1) indicates the operational error related to command and control; error register 2 and 3 (RHER 2, RHER 3) indicate drive error conditions. Two bits of RHER 3 (SKI and OCYL) indicate seek errors and are used to calculate the seek error rate (Paragraph 8.2.3). Six bits of RHER 1 (OPS, DTE, DCK, HCRC, HCE, and ECH) indicate data errors; the remaining bits of RHER 1 indicate command and control errors. Table 6-1 lists indications of the various error types and their explanations.

If all ECCs are installed, MAINDEC-10-DDRPJ and MAINDEC-10-DDRPK should run with no errors detected. Error definitions for MAINDEC-10-DDRPI are listed in the following paragraphs.

8.2.1 Soft Errors

Any error recoverable by the retry sequence (including retry, offset, and ECC) constitutes a soft error.

8.2.2 Hard Errors

Any error not recoverable the retry sequence constitutes a hard error. No hard errors are permitted.

8.2.3 Seek Errors

Seek errors include SKI, OCYL, or HCE (header compare errors) where the printout shows that the drive is on the wrong cylinder. HCE logic faults and miscompares of sector and track are not seek errors. The allowable error rate for seek errors is 1 error per 10^6 seeks.

8.2.4 Pack-Attributable Errors

Pack-attributable errors include any errors (DCK, ECH, OPI, DTE, etc.) that occur on the same cylinder and head (track) more than once, even though they may not occur every time. A record of the pack location of every error should be kept so that pack errors can be identified, as they may occur on a certain area as rarely as one time in ten. The pack specification allows a total of 20 pack errors maximum, no more than 5 of which may be hard pack errors.

8.2.5 Read Errors

Errors such as DCK, DCK/ECH, DTE, HCRC, or HCE where one or more bits are picked or dropped in the header field on the correct cylinder constitute read errors. The allowable error rate for read errors is 1 per 10^9 bits read, not counting pack errors.

8.3 RHP05/RHP06 ACCEPTANCE TESTING

The RHP05/RHP06 Field Acceptance Test is designed to demonstrate the performance of the RP05/RP06 Disk Drive when used with an RH10 controller.

1. Run MAINDEC-10-DDRHA for one pass (controller diagnostic).
2. Run one pass of:

 MAINDEC-10-DDRPJ for RP05 on each port
 MAINDEC-10-DDRPK for RP06 on each port.
3. Run one pass of MAINDEC-10-DDRPI, selecting "ACCEPT." (All drives may be selected at once.)
4. For dual-port systems, also run the special dual-port tests in MAINDEC-11-DDRPJ and -DDRPK according to the instructions in the diagnostic. A special test cable (7010507-02) is required.

8.4 DIAGNOSTIC DESCRIPTIONS

For complete descriptions of specific diagnostics, refer to the diagnostics themselves.

MAINDEC-10-DDRHA Deviceless Diagnostic

This program exercises the major portion of RH10 logic; no Massbus device necessarily has to be connected to the system. The I/O bus and DF10/DF10C channel bus paths are thoroughly exercised.

MAINDEC-10-DDRPJ (RP05); MAINDEC-10-DDRPK (RP06)

This program is a gate-by-gate check of the DCL, and attempts to exercise all of the disk logic functionally. It provides module callout capability upon error. When run, this diagnostic verifies the Massbus cables, drive, and DCL subsystems.

It starts with simple control bus transfers, moves on to seek exercising, and finally checks the data path. A loop-on-error capability is provided. A separate switch-selectable feature allows testing of dual-port systems. The head-alignment program is also included.

MAINDEC-10-DDRPI Reliability Diagnostic

This is a reliability diagnostic for an RHP05/RHP06 system consisting of any number of controllers with up to eight drives of either type, mixed. Basic and complex seek patterns and data transfers are executed. This program can be used to format or read packs, check the mechanical timing, establish the read error reliability, etc. It may also be run under time-sharing.

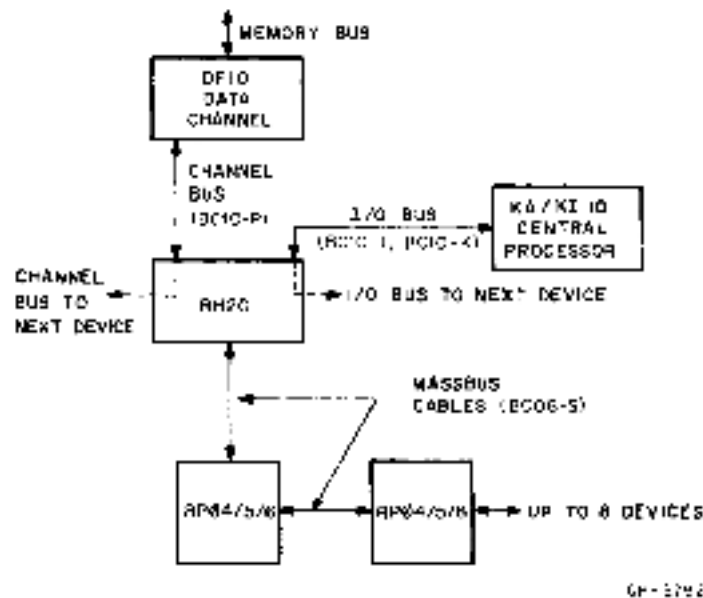

Figure 9-1 RH20/DF10/RP04/RP05/RP06 Interconnection Diagram

9.2.1.2 RP05/RP06 – Drives are plugged into a 3-phase power outlet through 4.6 m (15 ft) or less of ac cable supplied with the drive. One drive may be power-daisy-chained to another, but a third drive may not be added.

NOTE

When the drive is started, the pack should spin in a counterclockwise direction. If it does not, the phases must be reversed, or else the drive will not perform properly.

9.2.2 Massbus Cable Connections

Round Massbus cable (BC06S) is used to connect the RH20 to the drive, and to connect the drives to each other. Short cables (70-12066-00) 81.28 cm (32 in) long are used to connect the RP05/RP06 drives together. Skins must be removed from the drives before these cables can be used.

The last drive in the system must be terminated by a termination block (7009938) for the Massbus to operate correctly. Jumper W2 of the C terminator board must be the only jumper cut, as this enables Massfail.

NOTE

The terminator does not require power to work; thus, the last drive on the chain may be powered down.

Any mixture of RP04, RP05, and RP06 drives may be supported on the system provided that the proper software is run. Also, any drive may be dual-ported to the RH11 front end. This is accomplished via the same BC06 cables and another termination block. For software purposes, this drive should be logical zero.

NOTE

Unused ports do not require terminators.

If there are RH20s present without any drives connected to them, a terminator should be put on the RH20 plug to avoid spurious problems.

CHAPTER 10

RTP05/RTP06 FIELD ACCEPTANCE PROCEDURES AND DIAGNOSTICS

10.1 INTRODUCTION

Field acceptance testing is intended to demonstrate performance of the RP05/RP06 Disk Drive and/or the RTP05/RTP06 subsystem to the customer prior to his acceptance.

10.2 ERROR DEFINITIONS/RATES

The RP05/RP06 contains three registers to display the various error conditions possible. Error register 1 (RHER 1) indicates the operational error related to command and control; error registers 2 and 3 (RHER 2, RHER 3) indicate drive error conditions. Two bits of RHER 3 (SKI and OCYL) indicate seek errors and are used to calculate the seek error rate (Paragraph 10.2.3). Six bits of RHER 1 (OPS, DTE, DCK, HCRC, HCE, and ECH) indicate data errors; the remaining bits of RHER 1 indicate command and control errors. Table 6-1 lists indications of the various error types and their explanations.

If all ECOs are installed, MAINDEC-10-DFRPJ and MAINDEC-10-DFRPK should run with no errors detected. Error definitions for MAINDEC-10-DDRPI are listed in the following paragraphs.

10.2.1 Soft Errors

Any error recoverable by the retry sequence (including retry, offset, and ECC) constitutes a soft error.

10.2.2 Hard Errors

Any error not recoverable by the retry sequence constitutes a hard error. No hard errors are permitted.

10.2.3 Seek Errors

Seek errors include SKI, OCYL, or HCE (head compare errors) where the printout shows that the drive is on the wrong cylinder. HCE logic faults and miscompares of sector and track are not seek errors. The allowable error rate for seek errors is 1 error per 10^6 seeks.

10.2.4 Pack-Attributable Errors

Pack-attributable errors include any errors (DCK, ECH, OPI, DTE, etc.) that occur on the same cylinder and head (track) more than once, even though they may not occur every time. A record of the pack location of every error should be kept so that pack errors can be identified, as they may occur on a certain area as rarely as one time in ten. The pack specification allows a total of 20 pack errors maximum, no more than five of which may be hard pack errors.

10.2.5 Read Errors

Errors such as DCK, DCK/ECH, DTE, HCRC, or HCE where one or more bits are picked up or dropped in the header field on the correct cylinder constitute read errors. The allowable error rate for read errors is 1 per 10^9 bits read, not counting pack errors.

10.3 RTP05/RTP06 ACCEPTANCE TESTING

The RTP05/RTP06 Field Acceptance Test is designed to demonstrate the performance of the RP05/RP06 Disk Drive when used with an RH20 controller.

1. Run any applicable CPU and/or memory diagnostics.
2. Run one pass of MAINDEC-10-DFSXA, System Exerciser, to verify interaction between disk drive, controller, channel, and memory.
3. Run MAINDEC-10-DFRHB for one pass with no errors (controller diagnostic).
4. Run one pass of:
 - MAINDEC-10-DFRPJ for RP05 on each port
 - MAINDEC-10-DFRPK for RP06 on each port.
5. Run one pass of MAINDEC-10-DDRPI, selecting "ACCEPT." (All drives may be selected at once.)
6. For dual-port systems, also run the special dual-port tests in MAINDEC-11-DFRPJ and -DFRPK according to the instructions in the diagnostic. A special test cable (7010507-02) is required.

10.4 DIAGNOSTIC DESCRIPTIONS

For complete descriptions of specific diagnostics, refer to the diagnostics themselves.

MAINDEC-10-DFRIB

This is an RH20 controller diagnostic that checks the 3-board RH20 option as it interacts with the channel. It allows for testing of the Massbus data and control buses through a hardware wrap feature. A terminator must be used either on the end drive or on the RH20 plug itself if no drives are cabled to it. If drives are on the system, select a drive number not on the system, so that only the RH20 is tested.

MAINDEC-10-DFRPJ (RP05); MAINDEC-10-DFRPK (RP06)

This program is a gate-by-gate check of the DCL, and attempts to exercise all of the disk logic functionally. It provides module callout capability upon error. When run, this diagnostic verifies the Massbus cables, drive, and DCL subsystem.

It starts with simple control bus transfers, moves on to seek exercising, and finally checks the data path. A loop-on-error capability is provided. A separate switch-selectable feature allows testing of dual-port systems. The head alignment program is also included.

MAINDEC-10-DDRPI

This is a reliability diagnostic for an RTP05/RTP06 system consisting of any number of controllers with up to eight drives of either type, mixed. Basic and complex seek patterns and data transfers are executed. This program can be used to format or read packs, check the mechanical timing, establish the read error reliability, etc. It may also be run under time-sharing.

CHAPTER 11 INSTALLING THE RP05/RP06 INTO AN RWP05/RWP06 SUBSYSTEM

11.1 INTRODUCTION

When one or more RP05 is combined with one or more RH70 controller, the combination is designated as an RWP05 subsystem. When one or more RP06 is combined with one or more RH70 controller, the combination is designated as an RWP06 subsystem. More complete details regarding this type of installation can be found in the *RWP05/RWP06 Moving Head Disk Subsystem Maintenance Manual* (EK-RWP05-MM-001) and the *RP05/RP06 Device Control Logic Maintenance Manual* (EK-RP056-MM-001).

11.2 ELECTRICAL

Power cable connections, Unibus cable connections, and Massbus cable connections are described in the following paragraphs.

11.2.1 Power Cable Connections

The PDP-11/70 CPU mounting box contains a wired backplane that runs the full depth of the box. The Unibus signals are prewired on the backplane. Power to the RH70 is provided by the cabinet power supply as follows.

+5 V \pm 18.5 A max -15 V \pm 0.5 A max

11.2.2 Module Locations

The PDP-11/70 CPU mounting box contains the floating point unit, central processor, memory management, Unibus map, cache, five small peripheral controller (SPC) slots, the KW11-L line frequency clock, and up to four RH70 controllers. Figure 11-1 shows the location of the respective modules. Ensure that all modules are firmly seated in the proper slots when installing the device.

11.2.3 Massbus Cable Connections

Massbus connections to the RH70 are made via three 40-conductor ribbon cables. These cables plug into three M5904 transceivers in the RH70, and are designated Massbus Cable A, Massbus Cable B, and Massbus Cable C. These cables should be inserted into the modules with the edge marking facing the module handles. The other ends of these cables mate to the input/output connector block assembly on the connector panel with the edge marking facing up. The connections are made as indicated in Figure 11-2.

To terminate the Massbus, a 7009938 terminator pack assembly should be plugged into the output connector(s) of the last RP05/RP06 drive attached to the Massbus.

11.3 JUMPER CONFIGURATIONS

The following paragraphs describe the various jumper configurations on the BCT and MDP modules.

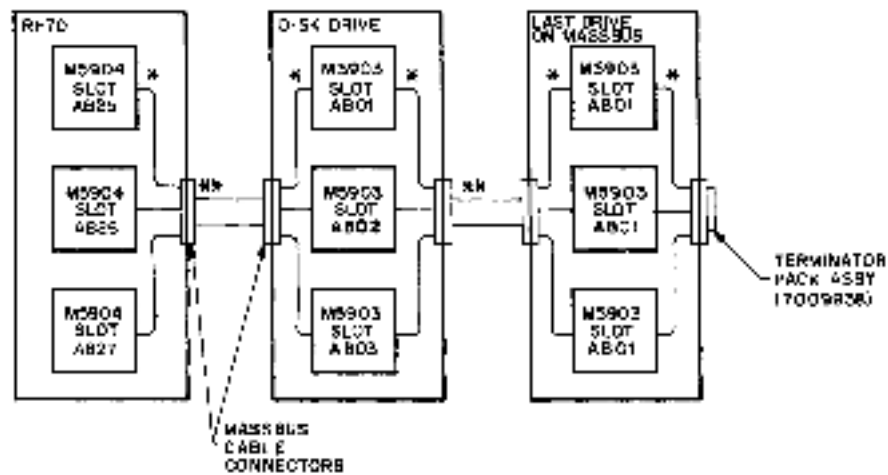

NOTES:

* Flat massbus cable (3) internal to RPS5/08 cabinet and to cabinet containing RP7D

MM Round massbus cable external to cabinets.

1. Last drive terminated with 700938 terminator pack only.

*	CONTROLLER A	CONTROLLER B	CONTROLLER C	CONTROLLER D
MASSBUS CABLE A	AB 25	AB 29	AB 33	AB 37
MASSBUS CABLE B	AB 26	AB 30	AB 34	AB 38
MASSBUS CABLE C	AB 27	AB 31	AB 35	AB 39

11-1424

Figure 11-2 Massbus Cable System Configuration

11.3.1 BCT Module (M8153)

The BCT module contains jumpers for register selection, BR level interrupt, and vector address.

11.3.1.1 Register Selection – The RH70 is capable of responding to 32 possible Unibus addresses, with the exact number dependent of the Massbus device. Jumpers W8–W15 select the block of Unibus addresses to which the RWP05/RWP06 subsystem will respond. The standard addressing block assigned is 776700–776752. For the RWP05/RWP06 subsystem, the following jumper configuration should be used. (Refer to D-CS-M8153-0-1, sheet 2 of 6.)

Jumper In = Binary 0

Address Bit	Jumper	Jumper In/Jumper Out
12	W14	OUT
11	W10	IN
10	W9	OUT
9	W8	IN
8	W11	IN
7	W13	IN
6	W15	IN
5	W12	OUT

ADDR
BIT

17	16	15	14	13	12	11	10	9	8	7	6	5	4	3	2	1	0
1	1	1	1	1	1	0	1	0	0	0	0	1	X	X	X	X	X
7			7			2		0			4 to 7			0 to 7			

The jumpers in E41 (D-CS-M8153-0-1, sheet 2 of 6) are selected for the appropriate number of registers in the subsystem minus 2. For example, there are 22 registers in the RWP05/RWP06 subsystem, so the jumpers are selected for a weighted value of 22 – 2, or 20, as shown below.

Jumper In = Binary 0

Slot	Jumper	Jumper In/Jumper Out
E41	1–16	OUT
	2–15	OUT
	3–14	IN
	4–13	IN
	5–12 (2)	IN
	6–11 (4)	OUT
	7–10 (8)	IN
	8–9 (16)	OUT

11.3.1.2 BR Level Interrupt – The priority jumper plug for the RH70 is normally set for the BR5 level. This plug is located in F022 (refer to D-CS-M8153-0-1, sheet 4 of 6).

11.3.1.3 Vector Address Jumpers – The interrupt vector transferred to the processor is jumper-selectable via jumpers W1–W7, representing vector bits 2–8. The RWP05/RWP06 subsystem has been assigned a vector address of 000254. The jumper configuration for this address is shown below.

Jumper In = Binary 1

Vector Bits	Jumper	Jumper In/Jumper Out
V2	W7	IN
V3	W3	IN
V4	W6	OUT
V5	W2	IN
V6	W5	OUT
V7	W1	IN
V8	W4	OUT

V8	V7	V6	V5	V4	V3	V2	V1	V0
0	1	0	0	0	0	1	0	0
2			5			4		

11.3.2 MDP Module (M8150)

The MDP module contains jumpers that allow maintenance personnel to disconnect wired-OR corrections from the Exclusive-OR network used to detect write-check errors.

These jumpers are designated W1–W4, and are shown on D-CS-M8150-0-1, sheet 6 of 9. The jumpers provide maintenance personnel with a method of isolating a faulty output (stuck low) of the wired-OR bus to one of four integrated circuit (IC) chips, which perform the exclusive-OR function during write-check operations. For example, if the output of the E21 and E23 open-collector line is stuck low when scoping of inputs indicates that it should be high, the faulty IC (E21 or E23) can be ascertained by removing jumpers W2 and W1. If, after the jumpers are removed, the outputs of the exclusive-OR gates in E23 are still low, the E23 chip is probably defective. If E23 outputs are high, the E21 chip is probably defective (outputs stuck low).

11.4 LIGHT-EMITTING DIODES (LEDs)

The following light-emitting diodes are incorporated into the RH70 Massbus controller logic BCT module (Figure 11-3) on the M8153.

- SSYN (Slave Sync) D-CS-M8153-0-1, sheet 3 of 6
- TRA (Transfer) D-CS-M8153-0-1, sheet 3 of 6
- BG IN (Bus Grant In) D-CS-M8153-0-1, sheet 4 of 6
- SACK (Selection Acknowledged) D-CS-M8153-0-1, sheet 4 of 6
- BBSY (Bus Busy) D-CS-M8153-0-1, sheet 4 of 6

These LEDs aid maintenance personnel in isolating certain system faults, as described in the following paragraphs.

System Fault No. 1 – Unibus on PDP-11/70 is in “hung” condition. (No operations can be performed on Unibus.)

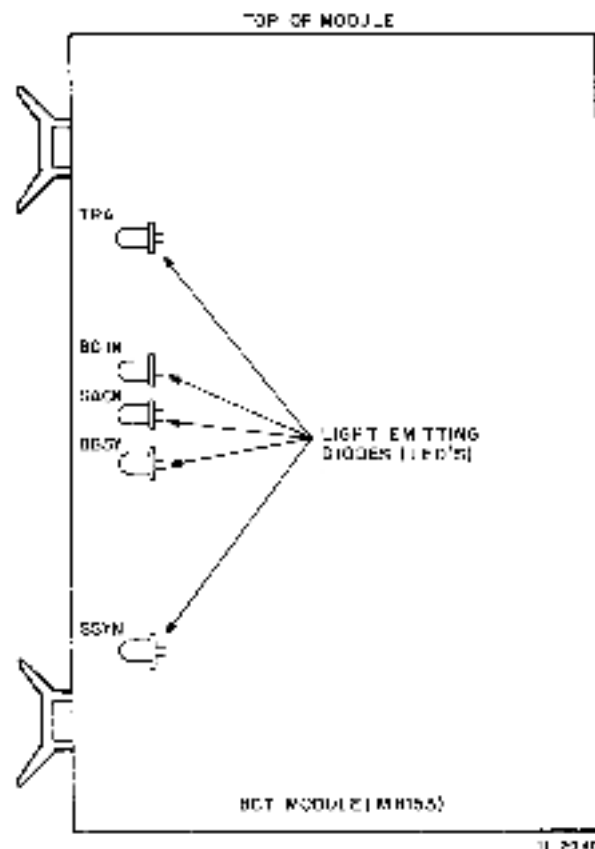

Figure 11-3 LED Physical Locations

Diagnosis - This condition may be caused by:

1. Stuck SACK
2. Stuck BBSY
3. Stuck SSYN.

The LED associated with the fault condition will be continuously illuminated. (LEDs may flicker intermittently during normal operation.)

System Fault No. 2 - Unibus device interrupt sequence not functioning properly. (Processor continuously loops in service routine and fails to execute instructions.)

Diagnosis - This condition is caused by discontinuity of the Bus Grant signal on the Unibus from the processor to the device interrupting, and may be caused by missing Grant continuity cards or defective circuitry, which normally passes Grant signals from device to device. These will cause the BG IN LED to become illuminated, indicating that the Unibus BG IN signal coming to the device is stuck high.

System Fault No. 3 - Processor attempts to read or write a remote register in the RWP05/RWP06 subsystem and receives an address error indication on the console (CPU traps to location 4).

Diagnosis - This condition may be caused by a stuck TRA signal on the Massbus that prevents the SSYN response from the RH70. This condition can be determined if local registers in the RH70 can be successfully accessed. If no register responds, the address jumpers may be selected improperly.

CHAPTER 12

RWP05/RWP06 FIELD ACCEPTANCE PROCEDURES AND DIAGNOSTICS

12.1 INTRODUCTION

Field acceptance testing is intended to demonstrate performance of the RP05/RP06 Disk Drive and/or the RWP05/RWP06 subsystem to the customer prior to his acceptance.

12.2 ERROR DEFINITIONS/RATES

The RP05/RP06 contains three registers to display the various error conditions possible. Error register 1 (RHER 1) indicates the operational error related to command and control; error registers 2 and 3 (RHER 2, RHER 3) indicate drive error conditions. Two bits of RHER 3 (SK1 and OCY1) indicate seek errors and are used to calculate the seek error rate (Paragraph 12.2.4). Four bits of RHER 1 (HCRC, HCF, ECH, and DCK, which may include DTE and FER) indicate data errors; the remaining bits of RHER 1 indicate command and control errors. Table 12-1 lists indications of the various error types and their explanations.

12.2.1 Hard Errors

Any failure to read data correctly after a complete recovery sequence with ECC enabled constitutes an irrecoverable, or hard, error. (A complete recovery sequence consists of 28 retries, 16 at the nominal head position, and 2 each at selected offsets; 10.1 μm , 20.3 μm , and 34.8 μm (400, 800, and 1200 microinches) for the RP05, and 5 μm , 10.2 μm , and 15.2 μm (200, 400, and 600 microinches) for the RP06. (The first release of the DIGITAL PDP-11 operating system does not include offset capability.) Errors that are not ECC-correctable include bursts greater than 11 bits in length and isolated dropped bits (separated by more than 11 bits) within a sector. The allowable error rate for hard errors is one error per 10^{12} bits read.

12.2.2 Soft Errors

Any failure to read data correctly on the first try that is then read successfully during a recovery sequence constitutes a recoverable, or soft, error. (Refer to Paragraph 12.2.1 for definition of a complete recovery sequence.) The allowable error rate for soft errors is one error per 10^9 bits read.

12.2.3 Pack-Attributable Errors

An error caused by imperfections in the recording surface is regarded as pack-attributable, or media-dependent. If the imperfection is less than 11 bits long, it is ECC-correctable and will appear as a soft error; if more than 11 bits long, it will appear as a hard error. On a given pack, pack-attributable errors will always appear at the same cylinder, sector, and track addresses, with an ECC POS REG value within 11 bits. The definitions of hard and soft errors in Paragraphs 12.2.1 and 12.2.2 apply only to randomly distributed errors, and do not take into account errors that are pack-attributable. Imperfections in the pack surface may be found by mapping the pack using the formatter program.

Table 12-1 RP05/RP06 Error Conditions

Bit	Bit Set Register	Error Type	Explanation
HCF HCRC	RHER 1 RHER 1	Soft	Sector Count Field/Desired. Sector Compare fails due to CRC failure.
HCRC	RHER 1	Soft	Sector Count Field matches desired sector field but there is CRC error.
HCRC FER	RHER 1 RHER 1	Soft	Format bit in first header word incorrect. NOTE FER without HCRC during an operation that reads the header indicates wrong format pack mounted.
DCK	RHER 1	Soft	Error detected during read operation by examination of ECC bytes; correctable by retry sequence.
DCK ECH	RHER 1 RHER 1	Hard	Error detected which is ECC uncorrectable through 28 retry sequence (16 retries at nominal head position and 12 with head offset).
SKI	RHER 3	Seek	1. Seek operation fails to complete within 85 ms of initiation. 2. Recalibration operation fails to complete within 500 ms of initiation. 3. Offset or return-to-centerline operation fail to complete within 10 ms of initiation.
SKI OCYL	RHER 3 RHER 3	Seek	Positioner has drifted off cylinder subsequent to completion of positioning operation.
HCE	RHER 1	Seek	Sector Count Field (RHLA) does not match Desired Sector Field (RHDS) and there is not a CRC error. This error is not caused by a positioner failure. It is due to a DCL failure. Therefore, HCE alone indicates an RP05/RP06 seek error and not a 677-51 or 677-01 drive seek failure.

12.2.4 Seek Errors

Any positioning operation that is not completed within a specified time (85 ms for Seek commands, 500 ms for Recalibrate commands, and 10 ms for Offset and Return to Centerline commands), or that terminates with the positioner in an incorrect location, constitutes a seek error. The allowable error rate for seek errors is one error per 10^9 seek operations.

12.3 RWP05/RWP06 FIELD ACCEPTANCE TEST

The tests described in Paragraph 12.4 may be used, individually or in combination, to demonstrate the performance of the RP05/RP06 Disk Drive when used with an RH70 controller.

12.4 DIAGNOSTIC MAINTENANCE

The diagnostic programs described herein are employed with the RWP04/RWP05/RWP06 subsystem. Refer to the applicable diagnostic operating procedures for more detailed information.

Test Programs

MAINDEC-11-DERHA	RH70 Controller Test
MAINDEC-11-DZRJA	Mechanical Read/Write Test
MAINDEC-11-DZRJE	Dual-Port Logic Test, Part 1
MAINDEC-11-DZRJF	Dual-Port Logic Test, Part 2
MAINDEC-11-DZRJG	RP04/RP05/RP06 Diskless Controller Test (Static I, Part I)
MAINDEC-11-DZRJH	RP04/RP05/RP06 Diskless Controller Test (Static I, Part II)
MAINDEC-11-DZRJI	RP04/RP05/RP06 Functional Controller Test (Static II, Part I)
MAINDEC-11-DZRJJ	RP04/RP05/RP06 Functional Controller Test (Static II, Part II)

System Exerciser Program

MAINDEC-11-DZRJD	Multidrive Exerciser
------------------	----------------------

Utility Programs

MAINDEC-11-DZRJB	Formatter Program
MAINDEC-11-DZRJC	Head Alignment Verification Program

12.4.1 MAINDEC-11-DERHA – RH70 Controller Test

This diagnostic verifies that the RH70 controller is operating correctly. The diagnostic can test up to four RH70 controllers simultaneously; however, an operating Massbus peripheral must be connected to each RH70 controller. The major tests in the diagnostic are:

1. Determining whether all registers in the controller can be read from or written into
2. Checking error conditions in the controller by causing an error and observing the results on the associated error bit in the CS1, CS2, or CS3 registers
3. Checking that the data buffer can accurately store and transfer data.

12.4.2 MAINDEC-11-DZRJG, MAINDEC-11-DZRJH – RP04/RP05/RP06 Diskless Controller Test

This program tests the RH70 and the DCL portion of the RP04/RP05/RP06 Disk Drive. The DCL makes the drive compatible with the Massbus, and must be plugged into the MDLI or appropriately terminated. (The MDLI is the mass device level interface that connects the DCL to the drive assembly.) The program does not use the disk surface or any signals from the MDLI.

If the disk is powered up, it must be in the Heads Unloaded position. After a successful run (with no errors) of this diagnostic, it can be ascertained that the DCL logic that processes the data is working properly. The logic that handles the mechanical commands is not tested in this diagnostic. All data commands use the Maintenance register in the Wraparound mode.

12.4.3 MAINDEC-11-DZRJI, MAINDEC-11-DZRJJ – RP04/RP05/RP06 Functional Controller Test

This diagnostic tests the DCL portion of the drive. It exercises the disk surface and the mechanics of the drive to prove proper operation of the subsystem. To run the diagnostic, a disk pack *with no vital information written on it* is essential. The disk pack need not be formatted.

After a successful run of this diagnostic (with no errors), it can be concluded that the DCL circuitry in the RP04/RP05/RP06 works successfully while not connected to the rest of the subsystem. System interaction and drive timing are left to other diagnostics. (This diagnostic presupposes that MAINDEC-11-DZRJG and MAINDEC-11-DZRJH have been run successfully.)

12.4.4 MAINDEC-11-DZRJA – Mechanical Read/Write Test

This program contains 15 tests, numbered 0–16. Tests 0–6 use a Read Header and Data command to read the cylinder, track, and sector information from the header. The tests then check the information for validity, ensuring that the seek operation functions properly. Tests 7–12 measure the rotational speed, the one-cylinder seek, the average seek, and the maximum seek times to ensure that they are all within the specified tolerances. Tests 13 and 14 ensure that the sector and track addressing circuitry is working properly. Test 15 ensures that the data storage and retrieval capabilities are operative. Test 16 is used to stress and check the read/write and servo systems.

The program starts by identifying itself and determining that all drives are available for testing. All drives are then tested, beginning with the lowest numerical drive and proceeding in sequential order. One pass (tests 0–15) is performed on each drive before moving to the next drive in sequence. The number of the drive to be tested is typed at the beginning of each pass. At the completion of each pass, an end-of-pass message is typed. After all drives have been tested, an end-of-test message is typed.

12.4.5 MAINDEC-11-DZRJE, MAINDEC-11-DZRJF – Dual-Port Logic Test (Parts 1 and 2)

This program checks the dual-port logic in the DCL portion of the drive; it requires a special adapter cable.

12.4.6 MAINDEC-11-DZRJD - Multidrive Exerciser

The RP04/RP05/RP06 Multidrive Exerciser program exercises from one to eight drives attached to the same RH70. If two or more of the drives are being exercised, operations on the drives are overlapped. (One drive performs a data transfer or write-check operation while others are performing seek/search operations.) Optimization makes it possible to maintain a high subsystem data transfer rate or a high positioning operation rate.

The performance of each drive is monitored by the program. If a drive exceeds a preset number of errors in any of several categories, that drive is automatically deassigned. (The operator may override the automatic deassignment feature.) The program reports performance statistics for each drive being exercised on request from the operator, or automatically at an interval determined by the operator.

All data transfer commands are used (i.e., Write Data, Write Header and Data, Read Data, and Read Header and Data), as well as Write-Check Data and Write-Check Header and Data commands. Recalibrate and Read-In Preset commands are used at startup and drive initialization. Recalibrate, Offset, and Return to Centerline commands are used during error processing.

Program/operator communications are through the console device; program options are selected by Switch register settings and errors are normally reported on the teletypewriter. However, if a line-printer is available, the program will use the printer for error message display.

All commands, data patterns, and data buffer sizes are selected randomly by the program. The addresses (e.g., cylinder, track, and sector) for each operation are also selected randomly.

At the completion of each operation, the program checks the RH70. The program requires data packs created by the Formatter program (MAINDEC-11-DERPL), the Read/Write Mechanical Test (MAINDEC-11-DERPK), or the Data Pack Generation command of the Exerciser program.

12.4.7 MAINDEC-11-DZRJB - Formatter Program

The RP05/RP06 Formatter program is designed to write and verify header and data information on all possible disk pack addresses with the intention of testing the retention of the recording surfaces. The format is maintained on a basis of 411 cylinders, 19 tracks per cylinder, and 22 sectors per track.

This program formats the disk pack on the assigned drive, one track at a time. The data fields are written with the selected pattern. Key words are written with 0s. Each track is verified with a Write-Check command immediately after it is written.

The portion of the pack to be formatted is determined by the first and last cylinder and track addresses, inclusively. A single track is the smallest element that may be formatted.

Write-check errors are reported when they are detected. If an error is detected, the sector must be rewritten and verified correctly *two successive times* to be considered usable. Sectors that cannot be written correctly twice after an error will be declared unacceptable by the program.

After the last track has been formatted and verified, an additional check is performed. The header of track 0 and sector 0 of each cylinder is read and compared by the software. This check is performed to isolate a possible positioner error that may have occurred during the format operation. Two such cases of positioner malfunction are: failure of the positioner to advance to the next cylinder, and advancement of the positioner past the desired cylinder.

12.4.8 MAINDEC-11-DZRJC - Head Alignment Verification Program

This program checks head alignment at cylinder 245, heads 0-18, and at cylinders 400 and 4, heads 0 and 18, and also rechecks alignment of cylinder 245, heads 0-18. The operator is notified if any head is out of alignment by more than the specified amount.

The procedure for checking head alignment is as follows.

1. Offset the positioner to $+30\ \mu\text{m}$ (+1200 microinches).
2. Store the sign change bit.
3. Move the positioner in the opposite direction in $0.64\text{-}\mu\text{m}$ (25-microinch) increments until the sign change bit changes value. Store the offset value.
4. Offset the positioner to $-30\ \mu\text{m}$ (-1200 microinches) and repeat steps 2 and 3.
5. Average the two sign change offset values and report if the selected head is misaligned by more than $\pm 3.9\ \mu\text{m}$ (± 150 microinches) for cylinder 245 or by more than $\pm 9\ \mu\text{m}$ (± 350 microinches) for cylinders 4 and 400.

Repeat the above sequence for all heads at cylinder 245, and for heads 0 and 18 at cylinders 4 and 400.

CHAPTER 13 OPTIONS

13.1 INTRODUCTION

The following paragraphs describe some of the ways in which the RP05/RP06 Disk Drive can be optionally configured.

13.2 DUAL-PORT OPERATION

The RP05/RP06 interface logic is designed to permit access by two different controllers, with the setting of the CONTROL switch on the drive front panel determining which controller is to be granted access. When the switch is set to the center position (A/B), the drive may be accessed by either controller, and will be controlled by that controller until its operation is completed.

13.2.1 Converting to Dual-Port

Converting an RP05/RP06 Disk Drive to dual-port operation takes approximately 2.5 manhours and requires only an 8.7 mm (11/32-inch) open or box wrench and a 2.4-mm (3/32-inch) hex (Allen) wrench. In order for the dual-port option to be operable, the M7775 (dual-port) board must be at Etch Rev. C or higher and CS Rev. D or higher.

13.2.2 Conversion Procedure

To convert the RP05/RP06 Disk Drive from single-port to dual-port operation, proceed as follows.

1. With power OFF, move the drive (if necessary) so that the side cover of the DCL is accessible.
2. Remove the side cover, revealing a metal plate.
3. Remove the six screws holding the metal plate, and remove the plate.
4. Remove the rear cover of the DCL.
5. Loosen the two fastener screws at the top of the DCL assembly (Figure 13-1). Pivot the card nest down to the horizontal position (Figure 13-2).
6. Loosen the two fastener screws (Figure 13-3) that are holding the air flow cover closed. Lift the air cover to the vertical position (Figure 13-4).
7. Remove the three cable clamps (two on the left-hand side, one at the bottom inside the frame).
8. Lay the new harness (Port B) in position over the existing harness (Port A), with the red-lined edge of the cabling up along the side of the card nest. Pull the new harness until the top cable connector is flush with the front of the card nest (Figure 13-2).

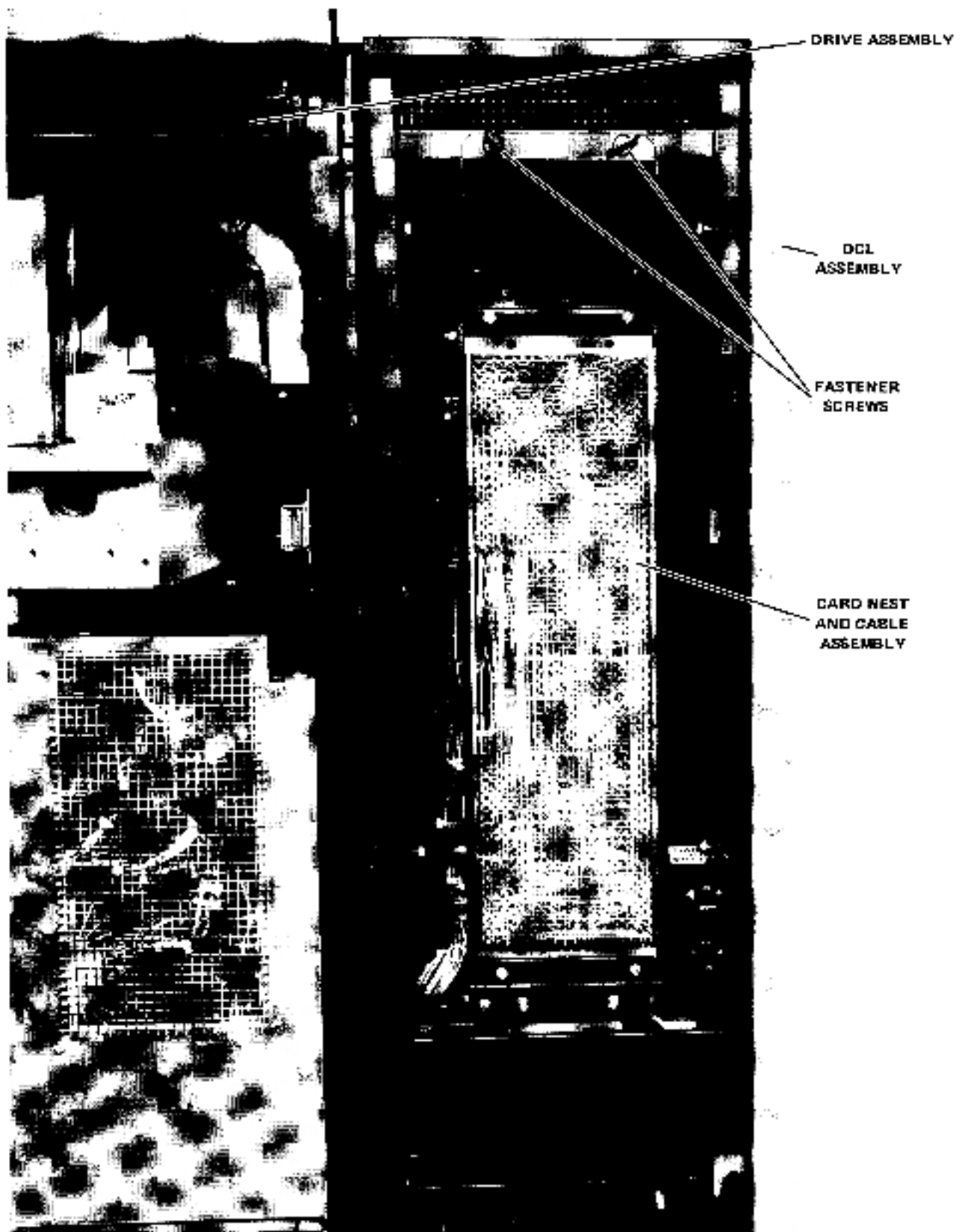

7777-1

Figure 13-1 Drive and DCL Assemblies Rear View, Rear Panels Removed

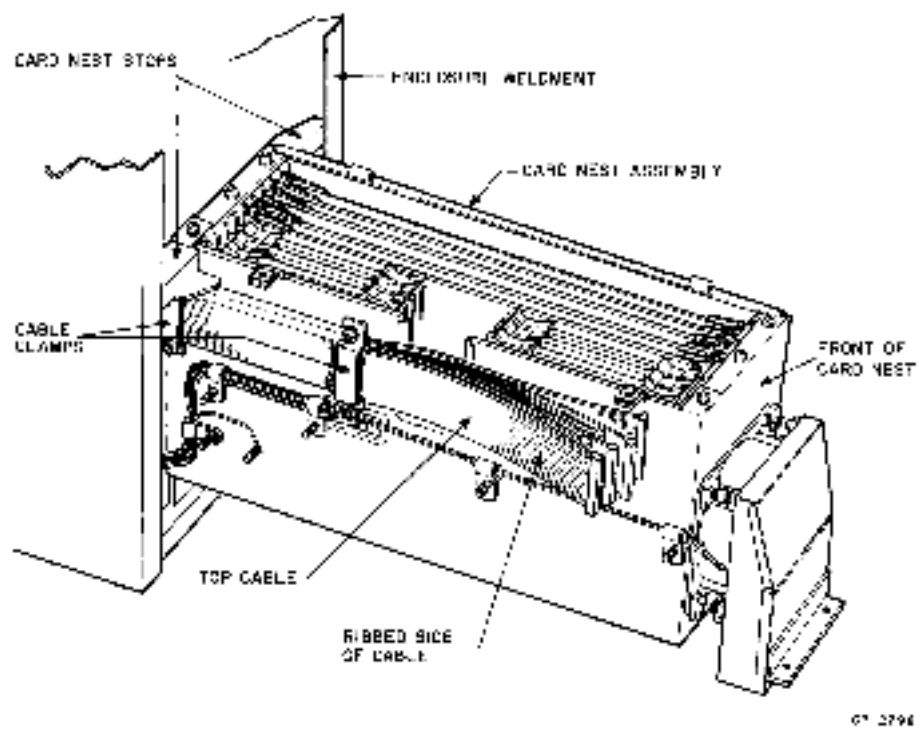
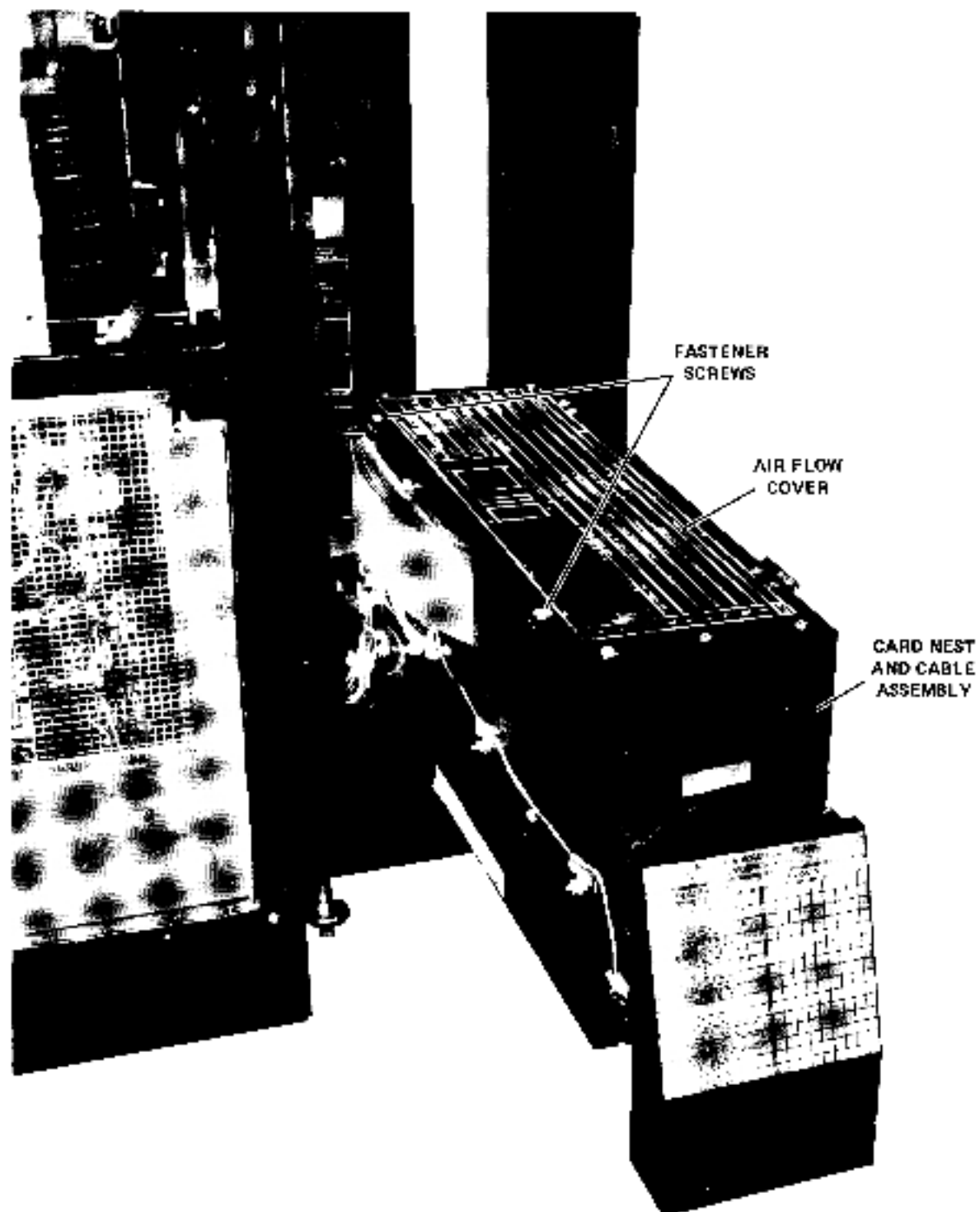
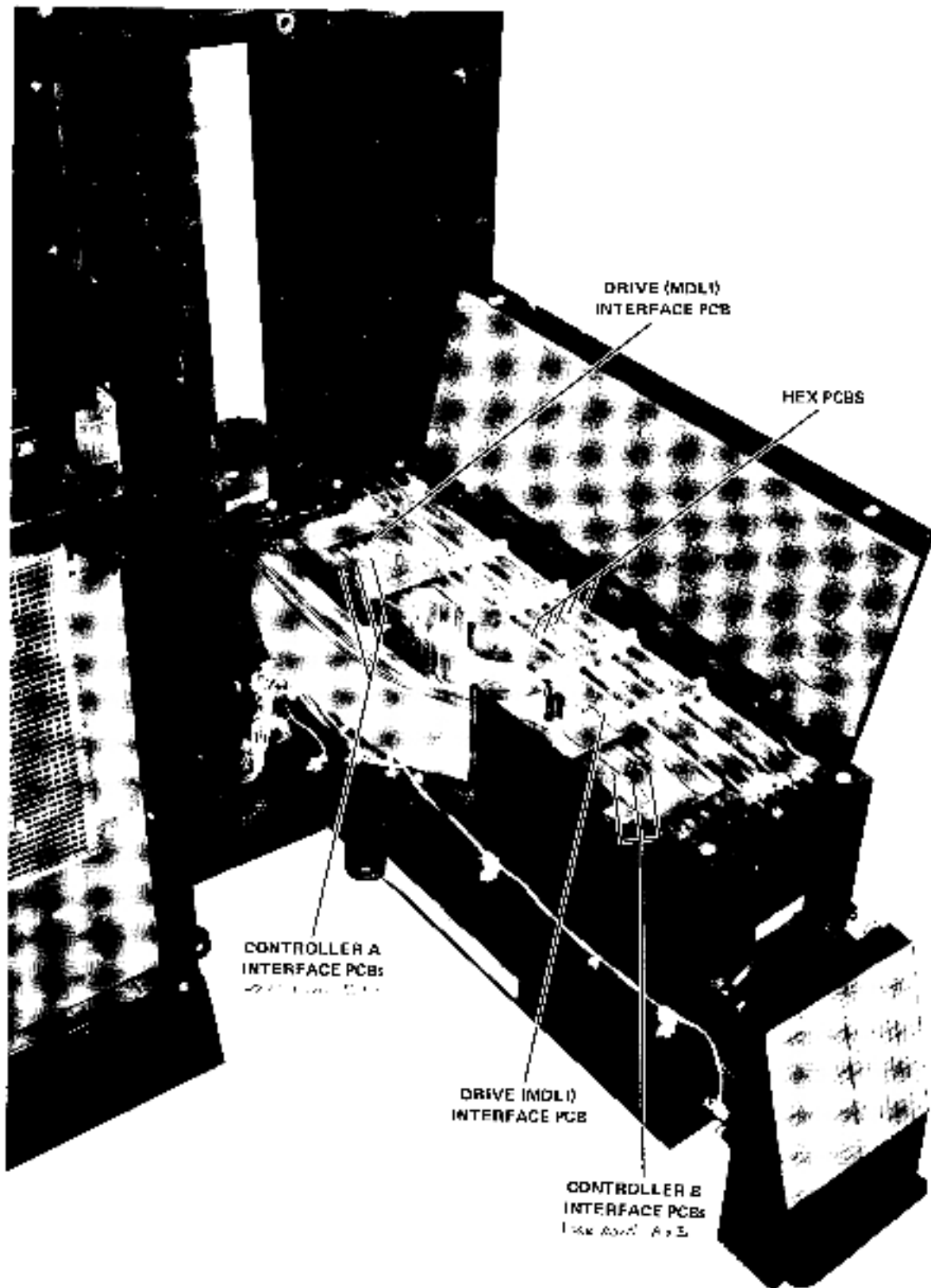

Figure 13-2 Card Nest in Horizontal Position



7777-5

Figure 13-3 DCL Rear View, Card Nest and Cable Assembly Extended



777-4

Figure 13-4 Card Nest and Cable Assembly PCB Layout

9. Twist the Port B harness the way the Port A harness is twisted, so that the Port B harness is above the Port A harness after the twist.
10. Replace the three cable clamps temporarily to support the Port B harness while proceeding with subsequent steps.
11. Attach the two cables closest to the side of the card nest to an M5903 Driver/Receiver module as shown in Figure 13-5; this will be Module C of Port B.
12. Attach the two cables in the middle of the Port B cable group to another M5903 Driver/Receiver module as shown in Figure 13-6; this will be Module B of Port B.
13. Attach the two outside cables to another M5903 as shown in Figure 13-7; this will be Module A of Port B.
14. Plug the M5903 modules into the card nest as shown in Figure 13-8, with Module A in Slot 1, Module B in Slot 2, and Module C in slot 3.
15. Run the other end of the Port B cables out through the top two Massbus connector holes, which should be empty.
16. Connect the cables to Massbus connectors, as follows:

B Input		B Output
Cable A	Top	Cable C
Cable B	Middle	Cable B
Cable C	Bottom	Cable A

The red-lined edge should be up with respect to the retainer spring.

17. Install the two Massbus connectors into the appropriate holes, using four hex screws on each; check the reverse side of the connector to ensure that no pins popped out when the cable was secured.
18. Tighten all three of the cable clamps, taking care not to pinch the cable edges.
19. Return the air flow cover to the horizontal position; remove the black-tape that covers the Port B decal.
20. Use the 76-cm (30-inch) Massbus cable to connect the drive with the succeeding one; if this is the last drive on the string, use a terminator.
21. Remove the M7776 Error Correction Logic module; cut Jumper W9.
22. Replace the M7776 module; when scoped, pin CU2 should now represent a logic 1 (+3 V), necessary for dual-port operation.
23. Fasten the air flow cover closed, using the two fastener screws (Figure 13-3).
24. Close the card nest; fasten with two fastener screws (Figure 13-1).
25. Replace the rear cover, metal plate, and side cover, and move the drive back into position.

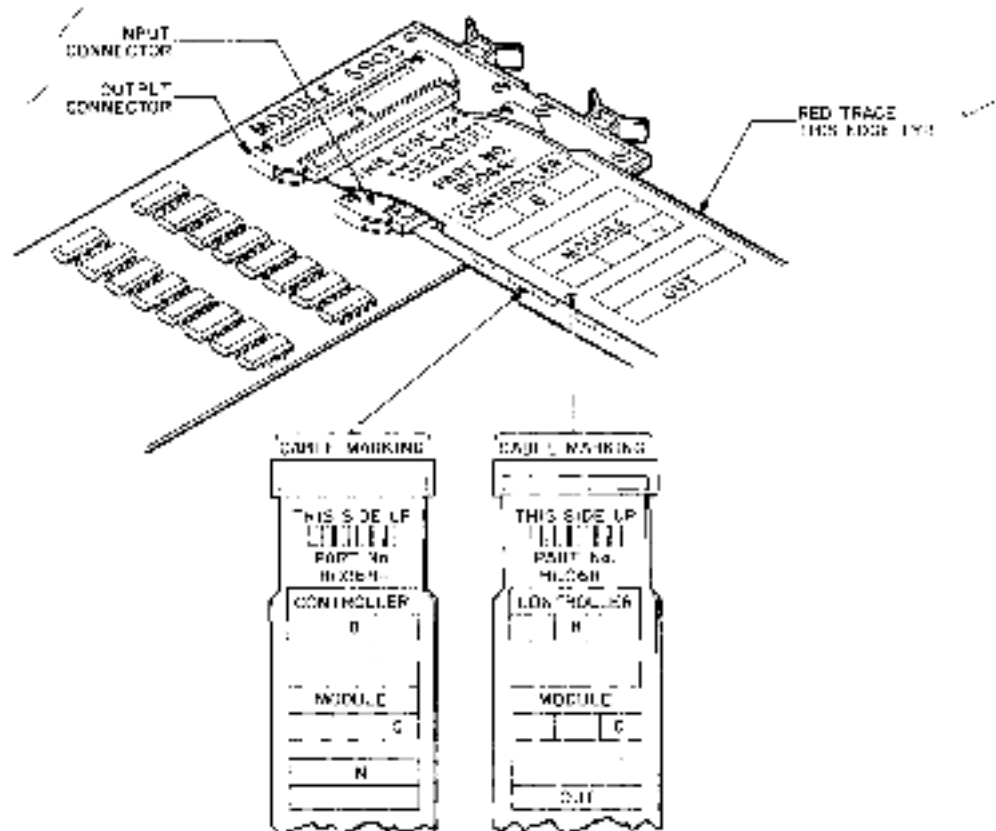

64-2794

Figure 13-5 Connecting Module C (M5903)

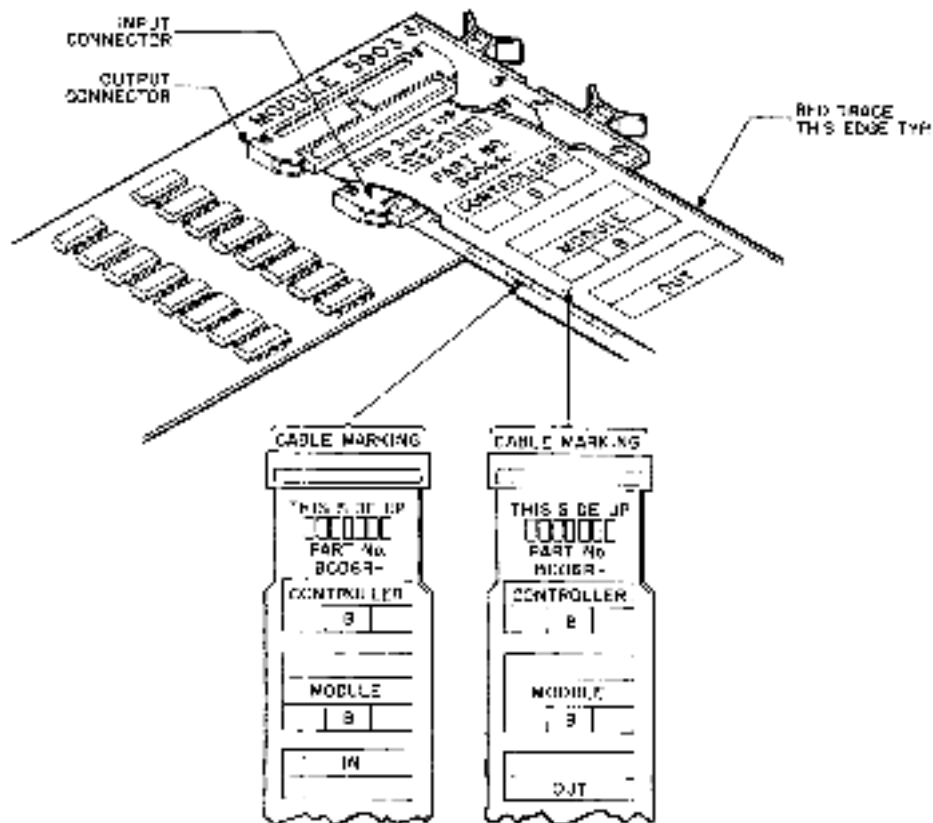

CP 2786

Figure 13-6 Connecting Module B (M5903)

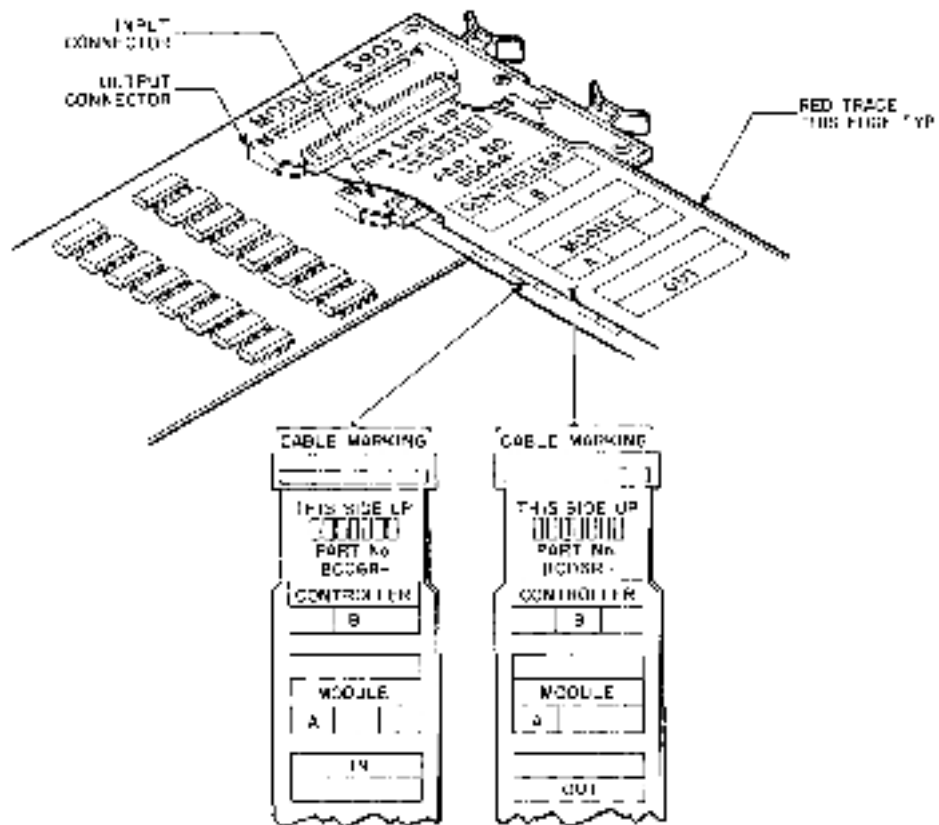

67 2736

Figure 13-7 Connecting Module A (M5903)

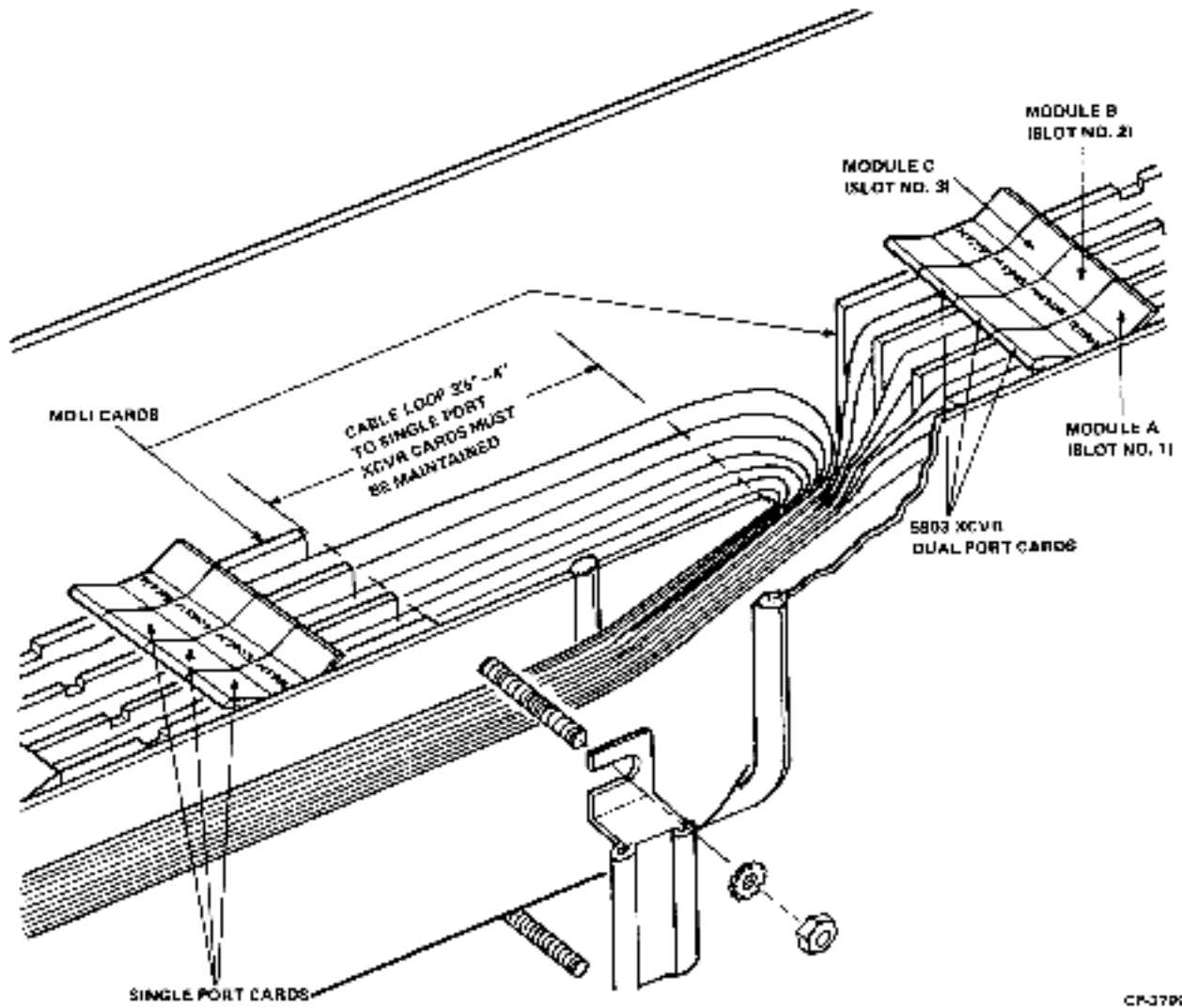

Figure 13-8 Module Locations of M5903S

13.3 UPGRADING THE RP05 TO AN RP06

13.3.1 Introduction

Materials Required

1. RP06-U Upgrade Kit (kit includes RP06-P data pack)
2. 200-megabyte CE Pack (29-22193)
3. RP05/06 Perch Tester

Reference Material

1. *RP05/06 Maintenance Manual* (ER-00012)
2. *RP05/06 Logic Manual* (EK-RP05M-TM-V02)
3. *RP05/06 DCL Maintenance Manual* (EK-RP054-MM-001)
4. *RP05/06 IPB Manual* (ER-00011)

Estimated Time to Install – 8 hours

13.3.2 Mechanical Conversion

1. Remove absolute filter by removing hose clamp under shroud per Paragraph 4.1.2.0.
2. Remove the spindle ground from the spindle by removing two mounting screws and one washer spacer from deck plate. (See Figure 6, sheet 3 in the *RP05/06 IPB Manual*.)
3. Remove glass door by first removing door bumpers/anti-lift (2×) from glass door tracks, then slide glass door forward out of drive. (See Figure 2 in the *RP05/06 IPB Manual*.)
4. Remove shroud cover by removing the four screws attaching the shroud cover to the glass door tracks (logic gate to be pushed forward to remove two screws at the rear of shroud cover).

CAUTION

When removing or installing shroud, take special care not to damage the pack sensor and the pack sensor seal.

5. Remove the shroud by removing six screws. First, remove the two screws located behind shroud air baffle, then remove the four screws at bottom of shroud which attach the shroud to the deck plate. (See Figure 6, sheet 1 in the *RP05/06 IPB Manual*.)
6. Remove the 100-megabyte spindle lock shaft from the spindle by removing the three allen screws, the holding plate, and the conical spring. Then, with one hand prepared to catch the falling lock shaft, carefully tap the top of the lock shaft to release it from the spindle. (See Figure 6, sheet 3 in the *RP05/06 IPB Manual*.)
7. Place all brass shims removed with the 100-megabyte lock shaft on the 200-megabyte lock shaft prior to installation into the spindle (three shims maximum). Lightly coat lock shaft O-ring with Andoc C™ or equivalent. Wipe all excessive oil from lock shaft.

™Andoc C is a trademark of the Esso Oil Company.

8. Install the 200-megabyte lock shaft (Memorex Part No. 215013) by inserting it through the bottom of the spindle. Reinstall the conical spring, holding plate, and the three allen screws removed in step 6.
9. Head conversion: Remove all 100-megabyte heads (all hardware will be re-used).
10. Remove the 1000-megabyte head load cams (2×) (black) from cam towers by removing four screws in each cam.
11. Install the 200-megabyte head load cams (2×) (white, Memorex Part No. 215087), using screws removed in step 10. (See Figure 6, sheet 1 in the *RP05/06 IPB Manual*.)
12. Install the shroud, by first engaging the shroud to the locating pin in the cam tower, using screws removed in step 5.
13. Install shroud cover, using screws removed in step 4. (Inspect shroud cover seal for damage. If damage is present, replace shroud cover.)
14. Install the glass door and door bumper anti-lift (2×), using screws removed in step 3.
15. Install the spindle ground, spacer washer, and screws removed in step 2.
16. Install absolute filter removed in step 1.
17. Logo replacement: Raise indicator panel, remove lamp matrix PCB, then remove the five nuts retaining the trim strip to the indicator panel. Then, remove the logo/dead front by sliding the logo/dead front free of the indicator panel; replace with logo/dead front (Memorex Part No. 215745), in reverse of removal procedure. (See Figure 3 in the *RP05/06 IPB Manual*.)

13.3.3 Head Conversion

CAUTION

Strict adherence to the technical manual is mandatory when installing heads. Improper installation of heads may cause catastrophic head-to-disk interference.

1. Install all 200-megabyte heads, using head installation tool (Memorex Part No. 210105). Using torque tool (Memorex Part No. 210109), torque data heads to initial torque values. Torque servo head to final torque. (Refer to Paragraph 4.6.2 in the *RP05/06 Maintenance Manual*.)
 - a. Data Heads Torque
 - Initial torque: 2.5 ± 0.5 in-lb
 - Final torque: 6.0 ± 1 in-lb
 - b. Servo head torque: 6 ± 1 in-lb
2. Observing from the shroud, inspect all heads to ensure they are positioned properly on head load cams.

13.3.4 Electrical Conversion

1. Replace the 100-megabyte VSER PCB (location D14) with 200-megabyte VSER PCB (Memorex Part No. 012476).
2. Replace the 100-megabyte PSER PCB (location D15) with the 200-megabyte PSER PCB (Memorex Part No. 012481).
3. Replace the 100-megabyte WLOG PCB (location D17) with the 200-megabyte WLOG PCB (Memorex Part No. 012746).
4. Rework the input PCB by removing the wire between pins 8 and 9 in location 1-C or location J) on component side of PCB. Cut trace J1 if necessary.
5. Replace the 100-megabyte matrix PCBs (2x) located on cam tower with the 200-megabyte matrix PCBs (2x) (Memorex Part No. 012491). Then, plug the head connector into the matrix PCB.
6. In DCL, install jumper W3 on seek and search control logic M7786.
7. In DCL, reconfigure drive type number on error correction logic M7776 for one of the following drive types.

Drive Type Number (Octal)	Drive Type
020022	RP06-A (single control)
024022	RP06-B (dual control)

13.3.5 Test Procedure

1. Install double-density scratch pack, non-CE-pack.
2. Power drive up.
3. After drive disk pack has been rotating at 3600 rev/min for 5 minutes, carefully perform hand launch of heads as a precaution to assure that all heads are installed and flying correctly. Then, perform first seek with the lap plug installed. (See Paragraphs 4.3.3.1 to 4.3.3.3.)

CAUTION

During the hand launch of heads or during first seek with lap installed, if there is any high pitch or abrasive sound noticeable from the disk, retract the heads immediately and power drive down and inspect all heads for possible damage.

4. Power drive down and remove disk pack.
5. Install double-density CE pack, start drive, and allow drive temperature to stabilize for one hour.
6. Align heads using model 800 tester and head alignment tool. After heads are aligned, torque all data heads to final torque. (Refer to Paragraph 4.6.3 in the *RP05/06 Maintenance Manual*.)
7. Install data pack RP06-P and perform diagnostic and acceptance tests per field acceptance procedure as described in Chapter 6, 8, 10, or 12.

Reader's Comments

RP05/RP06 DISK DRIVE
INSTALLATION MANUAL
EK-RP056-IN-001

Your comments and suggestions will help us in our continuous effort to improve the quality and usefulness of our publications.

What is your general reaction to this manual? In your judgment is it complete, accurate, well organized, well written, etc.? Is it easy to use? _____

What features are most useful? _____

What faults do you find with the manual? _____

Does this manual satisfy the need you think it was intended to satisfy? _____

Does it satisfy *your* needs? _____ Why? _____

Would you please indicate any factual errors you have found. _____

Please describe your position. _____

Name _____ Organization _____

Street _____ Department _____

City _____ State _____ Zip or Country _____

Fold Here

Do Not Tear - Fold Here and Staple

**FIRST CLASS
PERMIT NO. 33
MAYNARD, MASS.**

**BUSINESS REPLY MAIL
NO POSTAGE STAMP NECESSARY IF MAILED IN THE UNITED STATES**

Postage will be paid by:

Digital Equipment Corporation
Technical Documentation Department
Maynard, Massachusetts 01754



DIGITAL EQUIPMENT CORPORATION **digital** WORLDWIDE SALES AND SERVICE

MAIN OFFICE AND PLANT

Maynard, Massachusetts, U.S.A. 01754 • Telephone: From Metropolitan Boston: 646-8600 • Elsewhere: (617)-897-5111
TWX: 710-347-0212 Cable: DIGITAL MAYN Telex: 94-8457

DOMESTIC

NORTHEAST

REGIONAL OFFICE:

235 Wyman Street, Waltham, Mass. 02154
Telephone: (617)-890-0330/0310 Dataphone: 617-890-3012 or 3013

CONNECTICUT

Meriden
240 Pomeroy Ave., Meriden, Conn. 06540
Telephone: (203)-237-8441/7466 Dataphone: 203-237-8205

Fairfield
1275 Post Road, Fairfield, Conn. 06430
Telephone: (203)-255-5991

NEW YORK

Rochester
130 Allens Creek Road, Rochester, New York
Telephone: (716)-461-1700 Dataphone: 716-244-1680

Syracuse
6700 Thompson Road, Syracuse, New York 13211
Telephone: (315)-437-1593/7085 Dataphone: 315-454-4152

MASSACHUSETTS

Marlborough
One Iron Way
Marlborough, Mass. 01752
Telephone: (617)-481-7400 Telex: 710-347-0348

MID-ATLANTIC

REGIONAL OFFICE:

U.S. Route 1, Princeton, New Jersey 08540
Telephone: (609)-452-2940

FLORIDA

Orlando
Suite 130, 7001 Lake Ellenor Drive, Orlando, Florida 32809
Telephone: (305)-851-4450 Dataphone: 305-859-2360

GEORGIA

Atlanta
2815 Clearview Place, Suite 100
Atlanta, Georgia 03040
Telephone: (404)-451-7411 Dataphone: 305-859-2360

NORTH CAROLINA

Durham/Chapel Hill
Executive Park
3700 Chapel Hill Blvd.
Durham, North Carolina 27707
Telephone: (919)-489-3347 Dataphone: 919-489-7832

NEW JERSEY

Fairfield
253 Passaic Ave., Fairfield, New Jersey 07006
Telephone: (201)-227-9280 Dataphone: 201-227-9280
Metuchen
95 Main Street, Metuchen, New Jersey 08840
Telephone: (201)-549-4100/2000 Dataphone: 201-548-0144

MID-ATLANTIC (cont.)

Princeton
U.S. Route 1, Princeton, New Jersey 08540
Telephone: (609)-452-2940 Dataphone: 609-452-2940

NEW YORK

Long Island
1 Huntington Quadrangle
Suite 1507 Huntington Station, New York 11746
Telephone: (516)-694-4131 (212)-895-8095
Dataphone: 516-293-5693

Manhattan
810 7th Ave., 22nd Floor
New York, N.Y. 10019
Telephone: (212)-582-1300

PENNSYLVANIA

Philadelphia
Digital Hall
1740 Walton Road, Blue Bell, Pennsylvania 19422
Telephone: (215)-825-4200

TENNESSEE

Knoxville
6311 Kingston Pike, Suite 21E
Knoxville, Tennessee 37919
Telephone: (615)-588-6571 Dataphone: 615-584-0571

WASHINGTON D.C.

Lanham 30 Office Building
4900 Princess Garden Parkway, Lanham, Maryland
Telephone: (301)-459-7900 Dataphone: 301-459-7900 X53

CENTRAL

REGIONAL OFFICE:

1850 Frontage Road, Northbrook, Illinois 60062
Telephone: (312)-498-2500 Dataphone: 312-498-2500
Ex. 78

INDIANA

Indianapolis
21 Beachway Drive, Suite G
Indianapolis, Indiana 46224
Telephone: (317)-243-8341 Dataphone: 317-247-1212

ILLINOIS

Chicago
1850 Frontage Road
Northbrook, Illinois 60062 Dataphone: 312-498-2500

LOUISIANA

New Orleans
3100 Ridgelake Drive, Suite 108
Metairie, Louisiana 70002
Telephone: (504)-837-0257 Dataphone: 504-833-2800

CENTRAL (cont.)

MICHIGAN

Ann Arbor
230 Huron View Boulevard, Ann Arbor, Michigan 48103
Telephone: (313)-761-1150 Dataphone: 313-769-9883

Detroit
23777 Greenfield Road
Suite 189
Southfield, Michigan 48075 Dataphone: 313-557-3063

MINNESOTA

Minneapolis
8030 Cedar Ave. South, Minneapolis, Minnesota 55420
Telephone: (612)-854-6562-3-4-5 Dataphone: 612-854-1410

MISSOURI

Kansas City
12401 East 43rd Street, Independence, Missouri 64055
Telephone: (816)-252-2300 Dataphone: 816-461-3100

ST. LOUIS

Suite 110, 115 Progress Parkway
Maryland Heights, Missouri 63043
Telephone: (314)-878-4310 Dataphone: 816-461-3100

OHIO

Cleveland
2500 Euclid Avenue, Euclid, Ohio 44117
Telephone: (216)-946-8484 Dataphone: 216-946-8477

DAYTON

3101 Kettering Boulevard
Dayton, Ohio 45439
Telephone: (513)-294-3323 Dataphone: 513-298-4724

OKLAHOMA

Tulsa
3140 S. Winston
Winston Sq. Bldg., Suite 4, Tulsa, Oklahoma 74135
Telephone: (918)-749-4476 Dataphone: 918-749-2714

PENNSYLVANIA

Pittsburgh
400 Penn. Center Boulevard, Pittsburgh, Pennsylvania 15235
Telephone: (412)-243-9404 Dataphone: 412-824-9730

TEXAS

Dallas
Plaza North, Suite 513
2880 LBJ Freeway, Dallas, Texas 75234
Telephone: (214)-620-2051 Dataphone: 214-620-2061

HOUSTON

6656 Hornwood Drive
Monterey Park, Houston, Texas 77036
Telephone: (713)-777-3471 Dataphone: 713-777-1071

WISCONSIN

Milwaukee
8531 West Capitol Drive, Milwaukee, Wisconsin 53222
Telephone: (414)-463-9110 Dataphone: 414-463-9115

WEST

REGIONAL OFFICE:

310 Soquel Way, Sunnyvale, California 94086
Telephone: (408)-735-9200 Dataphone: 408-735-1820

ARIZONA

Phoenix
4358 East Broadway Road, Phoenix, Arizona 85040
Telephone: (602)-268-3488 Dataphone: 602-268-7371

CALIFORNIA

Santa Ana
2110 S. Anne Street, Santa Ana, California 92704
Telephone: (714)-979-2460 Dataphone: 714-979-6850

SAN DIEGO

6154 Mission Gorge Road
Suite 110, San Diego, California
Telephone: (714)-280-7880/7970 Dataphone: 714-280-7825

SAN FRANCISCO

1400 Terra Bella, Mountain View, California 94040
Telephone: (415)-964-6200 Dataphone: 415-964-1436

OAKLAND

7850 Edgewater Drive, Oakland, California 94621
Telephone: (415)-635-5453/7830 Dataphone: 415-562-2160

WEST LOS ANGELES

1510 Cotner Avenue, Los Angeles, California 90025
Telephone: (213)-479-3791/4318 Dataphone: 213-478-5626

COLORADO

7901 E. Bellevue Avenue
Suite 5, Englewood, Colorado 80110
Telephone: (303)-770-6150 Dataphone: 303-770-6628

NEW MEXICO

Albuquerque
10200 Manual N.E., Albuquerque, New Mexico 87112
Telephone: (505)-296-5411/5428 Dataphone: 505-294-2330

OREGON

Portland
Suite 168
5319 S.W. Westgate Drive, Portland, Oregon 97221
Telephone: (503)-297-3761/3765

UTAH

Salt Lake City
429 Lawn Dale Drive, Salt Lake City, Utah 84115
Telephone: (801)-487-4669 Dataphone: 801-467-0535

WASHINGTON

Bellevue
13401 N.E. Bellevue, Redmond Road, Suite 111
Bellevue, Washington 98005
Telephone: (206)-545-4058/455-5404 Dataphone: 206-747-3754

INTERNATIONAL

EUROPEAN HEADQUARTERS

Digital Equipment Corporation International Europe
81 route de l'Aire
1211 Geneva 26, Switzerland
Telephone: 42 79 50 Telex: 22 883

FRANCE

Digital Equipment France
Centre Silic — Cidex L 225
94533 Rungis, France
Telephone: 687-23-33 Telex: 26840

GRENOBLE

Digital Equipment France
Tour Mangin
16 Rue Du Gal Mangin
38100 Grenoble, France
Telephone: (76)-87-56-01 Telex: 212-32882

GERMAN FEDERAL REPUBLIC

Digital Equipment GmbH
MUNICH
8 Muenchen 13, Wallensteinplatz 2
Telephone: 0811-35031 Telex: 524-226

COLOGNE

5 Koeln 41, Aachener Strasse 311
Telephone: 0221-44-40-95 Telex: 888-2269
Telegram: Flip Chip Koeln

FRANKFURT

6078 Neu-Isenburg 2
Am Forstaus Gravebruch 5-7
Telephone: 06102-5526 Telex: 41-76-82

HANNOVER

3 Hannover, Podbielskistrasse 102
Telephone: 0511-69-70-95 Telex: 922-952

STUTTGART

D-7301 Kempt, Stuttgart
Marco-Polo-Strasse 1
Telephone: (0771)-45-50-65 Telex: 841-722-393

AUSTRIA

Digital Equipment Corporation Ges.m.b.H.
VIENNA
Mariahilferstrasse 136, 1150 Vienna 15, Austria
Telephone: 85 51 86

UNITED KINGDOM

Digital Equipment Co. Ltd.
U.K. HEADQUARTERS
Fountain House, Butts Centre
Reading RG1 7QN, England
Telephone: (0734) 583555 Telex: 8483278

BIRMINGHAM

Maney Buildings
29/31 Birmingham Rd., Sutton Coldfield
Warwickshire, England
Telephone: 021-355-5501 Telex: 337-060

BRISTOL

Fish Ponds Road, Fish Ponds
Bristol, England BS163HQ
Telephone: Bristol 651-431

EALING

Bilton House, Uxbridge Road, Ealing, London W.5
Telephone: 01-579-2334 Telex: 22371

EDINBURGH

Shiel House, Craigshill, Livingston,
West Lothian, Scotland
Telephone: 32705 Telex: 727113

LONDON

Management House
43 Parker St., Holborn, London
WC 2B 5PT, England
Telephone: 01-405-2614/4067 Telex: 27560

MANCHESTER

Arndale House
Chester Road, Stretford, Manchester M32 9BH
Telephone: (061)-865-7011 Telex: 668666

UNITED KINGDOM (cont.)

READING
Fountain House, Butts Centre
Reading RG1 7QN, England
Telephone: (0734)-583555 Telex: 8483278

NETHERLANDS

Digital Equipment N.V.
THE HAGUE
Sir Winston Churchillian 370
Rijswijk/The Hague, Netherlands
Telephone: 94 9220 Telex: 32533

BELGIUM

Digital Equipment N.V./S.A.
BRUSSELS
108 Rue D'Arlon
1040 Brussels, Belgium
Telephone: 02-139256 Telex: 25297

SWEDEN

Digital Equipment AB
STOCKHOLM
Englundavagen 7, 171 41 Solna, Sweden
Telephone: 98 13 90 Telex: 173 50
Cable: Digital Stockholm

NORWAY

Digital Equipment Corp. A/S
OSLO
Trondheimsveien 47
Oslo 5, Norway
Telephone: 02/68 34 40 Telex: 19079 DEC N

DENMARK

Digital Equipment Aktiefolag
COPENHAGEN
Hellerupvej 66
2900 Hellerup, Denmark

FINLAND

Digital Equipment AB
HELSINKI
Titismaantie 6
SF-00710 Helsinki 71
Telephone: (090) 370133
Cable: Digital Helsinki

SWITZERLAND

Digital Equipment Corporation S.A.
GENEVA
20, Quai Ernest Ansermet
Boite Postale 23, 1211 Geneva 8, Switzerland
Telephone No. 022 20 40 20 and 20 58 93 and 20 68 93
Telex: 28 92 01

ZURICH

Digital Equipment Corp. AG
Schaffhauserstr. 315
CH-8050 Zurich, Switzerland
Telephone: 01 46 41 91 Telex: 56059

ITALY

Digital Equipment S.p.A.
MILAN
Corso Garibaldi 49, 20121 Milano, Italy
Telephone: (02)-879-051/2/3/4/5 Telex: 843-33615

SPAIN

Digital Equipment Corporation Ltd.
MADRID
Atnio Ingenieros S.A., Enrique Larreta 12, Madrid 16
Telephone: 215 35 43 Telex: 27249

BARCELONA

Atnio Ingenieros S.A., Granduxer 76, Barcelona 6
Telephone: 221 44 66

ISRAEL

DEC Systems Computers Ltd.
TEL AVIV
Suite 103, Southern Habakuk Street
Tel Aviv, Israel
Telephone: (03) 443114/440763 Telex: 922-33-3163

CANADA

Digital Equipment of Canada, Ltd.
CANADIAN HEADQUARTERS
P.O. Box 11500
Ottawa, Ontario, Canada
K2H 8K8
Telephone: (613)-592-5111 TWX: 610-562-8732

TORONTO

2550 Goldenridge Road, Mississauga, Ontario
Telephone: (416)-270-9400 TWX: 610-492-7118

MONTREAL

9045 Cote De Liesse
Dorval, Quebec, Canada H9P 2M9
Telephone: (514)-636-9393 Telex: 610-422-4124

CALGARY/Edmonton

Suite 140, 6940 Fisher Road S.E.
Calgary, Alberta, Canada
Telephone: (403)-435-4881 TWX: 403-255-7408

VANCOUVER

Suite 202
644 S.W. Marine Dr., Vancouver
British Columbia, Canada V6P 5Y1
Telephone: (604)-325-3231 Telex: 610-929-2006

GENERAL INTERNATIONAL SALES

REGIONAL OFFICE

146 Main Street, Maynard, Massachusetts 01754
Telephone: (617) 897-5111
From Metropolitan Boston, 646-8600
TWX: 710-347-0217/0212
Cable: DIGITAL MAYN
Telex: 94-8457

AUSTRALIA

Digital Equipment Australia Pty. Ltd.
ADELAIDE
6 Montrose Avenue
Norwood, South Australia 5067
Telephone: (08)-42-1339 Telex: 790-82825

BRISBANE

133 Leichhardt Street
Spring Hill
Brisbane, Queensland, Australia 4000
Telephone: (072)-293088 Telex: 790-40616

CANBERRA

27 Collie St.
Fyshwick, A.C.T. 2609 Australia
Telephone: (062)-959073

MELBOURNE

60 Park Street, South Melbourne, Victoria 3205
Australia
Telephone: (03)-699-2888 Telex: 790-30700

PERTH

643 Murray Street
West Perth, Western Australia 6005
Telephone: (092)-21 4993 Telex: 790-92140

SYDNEY

P.O. Box 491, Crows Nest
N.S.W. Australia 2065
Telephone: (02)-439-2963 Telex: 790-20740

NEW ZEALAND

Digital Equipment Corporation Ltd.
AUCKLAND
Hilton House, 430 Queen Street, Box 2471
Auckland, New Zealand
Telephone: 75533

JAPAN

Digital Equipment Corporation International
Kowa Building No. 16 — Annex, First Floor
9-20 Akasaka 1-Chome
Minato-Ku, Tokyo 107, Japan
Telephone: 588-2771 Telex: J-26428
Rikei Trading Co., Ltd. (sales only)
Kozato-Kaikun Bldg.
No. 18-14 Nishishimbashi 1-Chome
Minato-Ku, Tokyo, Japan
Telephone: 5915246 Telex: 781-4208

PUERTO RICO

Digital Equipment Corporation De Puerto Rico
407 del Parque Street
Santurce, Puerto Rico 00912
Telephone: (809)-723-8068/67 Telex: 385-9056

ARGENTINA

BUENOS AIRES
Coasin S.A.
Virrey del Pino, 4071, Buenos Aires
Telephone: 52-3185 Telex: 012-2284

BRAZIL

RIO DE JANEIRO — GB
Ambriex S.A.
Rua Ceara, 104, 2 e 3 andares ZC - 29
Rio De Janeiro — GB
Telephone: 264-7406/0461/7625

SÃO PAULO

Ambriex S.A.
Rua Tupi, 535
Sao Paulo — SP
Telephone: 52-7806/1870, 51-0912

PORTO ALEGRE — RS

Rua Coronel Vicente 421/101
Porto Alegre