

Rack-Mountable VAXserver/VAX 4000-Series System Conversion Guide

Order Number EK-RM430-CG-001

**Digital Equipment Corporation
Maynard, Massachusetts**

January 1992

The information in this document is subject to change without notice and should not be construed as a commitment by Digital Equipment Corporation. Digital Equipment Corporation assumes no responsibility for any errors that may appear in this document.

Copyright © Digital Equipment Corporation 1992

All rights reserved.

Printed in U.S.A.

The following are trademarks of Digital Equipment Corporation.

DEC	PDP	VAX
MicroVAX	DSSI	ThinWire
VAXcluster	KDA	KLESI
DESTA	DECnet	TK
VAXserver		DIGITAL logo

This document was prepared using VAX DOCUMENT, Version 2.0.

Contents

Preface

v

Chapter 1 Rack-Mountable VAX/VAXserver 4000-300 to 4000-500 Conversion

- 1.1 Summary of Conversion 1-1
- 1.2 Before Installing the Kit 1-2
- 1.3 Unpacking the Kit 1-2
- 1.4 Installing the Kit 1-5
- 1.5 Removing and Replacing the BA441 Storage Backplane 1-10

Appendix A Mandatory Module Return Procedure and Forms

- A.1 Return Procedure A-1
- A.2 Digital Forms A-3
- A.3 Customer Administrative Services (CAS) District Offices A-13

Index

Figures

1-1	Conversion Kit Hardware Contents	1-4
1-2	Conversion Kit Software Contents	1-5
1-3	Model/Serial Label Location	1-7
1-4	Conversion and Serial Labels Location	1-8
1-5	Medallion Location	1-9
1-6	Removing the ISE Devices	1-11
1-7	Storage Backplane Assembly Showing the DSSI, SCSI and Power Connections	1-13
1-8	Backplane Assembly	1-15

Tables

1	Conversion Kits	v
---	---------------------------	---

Preface

This conversion guide describes how to install the 680XL-XX (4000-500 upgrade kit) in the Rack-Mountable VAX/VAXserver 4000 Model 300 system.

Intended Audience

This document is intended for Digital Services personnel and licensed self-maintenance customers.

Conversion Kits

Table 1 lists the system (before conversion), the conversion kit number, and the upgrade (after conversion).

Table 1: Conversion Kits

System	Conversion Kit Number	Upgrade
Rack-Mountable VAX/VAXserver 4000-300	680XL-AA, -AB, -AC, -AD, -AE, -AF -BA, -BB, -BC, -BD, -BE, -BF	Rack- Mountable VAX 4000-500 VAXserver 4000-500

Customer Responsibilities

Customers should not install the conversion kit unless they are qualified self-maintenance customers. Only qualified maintenance personnel should perform the installation procedure. If you are not a qualified self-maintenance customer, call Digital Services to schedule a system conversion.

It is the customer's responsibility to perform a software backup before a Digital Services representative arrives at your site.

When the conversion is complete, return the old CPU module to Digital. Appendix A contains forms that need to be completed by the Digital Services representative and signed by the customer and Digital Services representative.

Digital Services Responsibilities

The Digital Services representative should contact the customer to ensure that the customer's software is backed up before arriving at the site.

After installation of the conversion kit, the Digital Services representative must complete the following forms and remove them from this document by tearing them along the perforated line. The forms must be signed by the customer and the Digital Services representative. The following forms are in Appendix A:

- Digital Services Worksheet
- Installation Receipt–Customer Copy
- Installation Receipt–Digital Services Copy
- Return Material Checklist

The Digital Services representative should give the customer the signed Installation Receipt–Customer Copy. The representative should include the signed Installation Receipt–Digital Services Copy with the CPU module that is being returned to Digital to ensure the customer receives credit.

Organization

This document contains one chapter and one appendix:

- Chapter 1—Describes how to install the conversion kit 680XL-XX (4000-500 upgrade) in a Rack-Mountable VAX/VAXserver 4000-300 system.
- Appendix A—Contains forms for the return of the module and a list of the Customer Administrative Services (CAS) district offices.

The following conventions are used in this guide:

Convention	Meaning
CAUTION	Provides information to prevent damage to equipment or software.
NOTE	Provides general information about the current topic.

Related Documents

The following list contains related documents:

Documentation	Order Number
<i>BA440/BA430 Enclosure Maintenance</i>	EK-348AB-MG
<i>KA670 CPU System Maintenance</i>	EK-347AB-MG
<i>KA680 CPU System Maintenance</i>	EK-454AA-MG
<i>VMS License Management Utility Manual</i>	AA-LA33A-TE

Chapter 1

Rack-Mountable VAX/VAXserver 4000-300 to 4000-500 Conversion

This chapter describes how to convert a Rack-Mountable VAX 4000-300 system to a Rack-Mountable VAX 4000-500 system or a Rack-Mountable VAXserver 4000-300 system to a Rack-Mountable VAXserver 4000-500 system.

1.1 Summary of Conversion

The tasks required to convert from a Rack-Mountable VAX/VAXserver 4000 Model 300 system to a Rack-Mountable VAX/VAXserver 4000 Model 500 system are summarized as follows. To begin the actual conversion, go to Section 1.3.

1. Unpack and verify the contents of the conversion kit.
2. Have the customer back up the system software.
3. Run the diagnostics to verify system operation.
4. Shut down the system and slide the system out of the cabinet.

NOTE

If the conversion kit is one of the following variations, go to Section 1.5 and proceed with the system upgrade:

-AA, -AB, -AC, -AD, -AE, -AF

**If the conversion kit is one of the following variations, continue with step 5:
-BA, -BB, -BC, -BD, -BE, -BF**

For details on the following procedures see the applicable installation manual.

5. Open the H3604 console module and disconnect the CPU cables.
6. Remove the old CPU module and memory module (L4001-XX).
7. Install the new CPU module and memory module (L4004-XX).
8. Reconnect the CPU cable.
9. Close the H3604 console module.
10. Reconnect the H3604 external cable.
11. Install the new medallion and labels.
12. Run the diagnostics to verify system operation.
13. Have the customer verify that the system software loads and operates correctly.
14. Complete the forms in Appendix A.

1.2 Before Installing the Kit

Before installing the kit:

1. Have the customer back up the system disk before Customer Services arrives. It is the customer's responsibility to back up the system disk.
2. Power up the system and run diagnostics to verify system operation.
3. Turn off the system power before installing the kit.

1.3 Unpacking the Kit

To unpack the kit:

1. Make sure there is no external damage on the shipping container, such as dents, holes, or crushed corners.

2. Unpack the conversion kit and check its contents against the shipping invoice.

CAUTION

Modules can be damaged by static discharge if an antistatic wrist strap and antistatic mat are not used during handling. The wrist strap and mat are in the antistatic kit in the Digital Services toolkit.

Figure 1–1 lists the conversion kit contents for the following conversion kits:

- 680XL-AA
- 680XL-AB
- 680XL-AC
- 680XL-AD
- 680XL-AE
- 680XL-AF
- 680XL-BA
- 680XL-BB
- 680XL-BC
- 680XL-BD
- 680XL-BE
- 680XL-BF

Figure 1–1: Conversion Kit Hardware Contents

Description	Part Number	-AA	-AB	-AC	-AD	-AE	-AF	-BA	-BB	-BC	-BD	-BE	-BF
NVAX CPU Module	L4002-BA	X	X	X	X	X	X	X	X	X	X	X	X
64MB DRAM Array	MS690-CA	X		X				X		X			
128MB DRAM Array	MS690-DA		X		X				X		X		
Conversion Label	36-15946-00	X	X	X	X	X	X	X	X	X	X	X	X
Module Number Label	36-26883-C3	X	X	X	X	X	X	X	X	X	X	X	X
Logo/Model Label	36-35523-11	X	X	X	X	X	X	X	X	X	X	X	X
Storage Backplane	70-28602-02 (B01)	X	X	X	X	X	X						
Medallion	74-41672-11	X	X	X	X	X	X	X	X	X	X	X	X
Color Strip	74-40914-01	X	X	X	X	X	X	X	X	X	X	X	X
Conversion Guide	EK-RM430-CG	X	X	X	X	X	X	X	X	X	X	X	X
VAX 4000 Doc Kit	QZ-K42AA-GZ	X	X	X	X	X	X	X	X	X	X	X	X

CS-8954

Note

The system must have VMS Version 5.5 or higher to support all of the 680XL-XX upgrades. Also, the system must have a Revision B01 or higher of the storage backplane (70-28602-02) to support all 680XL-XX upgrades.

Figure 1–2 lists the conversion kit software contents.

Figure 1–2: Conversion Kit Software Contents

Description	Part Number	-AA	-AB	-AC	-AD	-AE	-AF	-BA	-BB	-BC	-BD	-BE	-BF
VMS Base (FAS)	QL-OO1AR-TB			X	X		X			X	X		
VMS 40 User	QL-OO1AR-TD	X	X			X		X	X			X	
DECnet Endnode	QL-DO4AR-GD	X	X			X		X	X			X	
DECnet F/F	QL-DO5AR-GB			X	X		X			X	X		X
VAXcluster	QL-VBRAR-GB			X	X		X			X	X		X

CS-8953

3. Unpack the CPU module and memory modules and place them on the grounded antistatic mat.
4. Save the packing material for returning the old module to Digital.
5. If any item is missing or damaged:
 - Contact the customer's sales representative.
 - Contact the customer's delivery agent.

1.4 Installing the Kit

The CPU and memory modules have ratchet ejector handles to ensure a snug fit against the system's backplane.

To install the conversion kit:

1. Turn off the power switch on the front bezel and release the four captive screws. Pull the chassis out.
2. Put on the grounded wrist strap and attach the alligator clip to the system's chassis.
3. Open the H3604 console module. Note the position of the internal cable connected to the module. Carefully disconnect the internal cable.
4. Remove the old CPU module and all memory modules and install the new CPU module and memory modules.

5. Reconnect the internal cable to the CPU module. Close and lock the H3604 console module.
6. Attach the new CPU label on the depression on the right-most side of the H3604 console module panel (see Figure 1-3).
7. Attach the new memory label to the depression on the left-most side of the H3604 console module panel.

Figure 1-3: Model/Serial Label Location

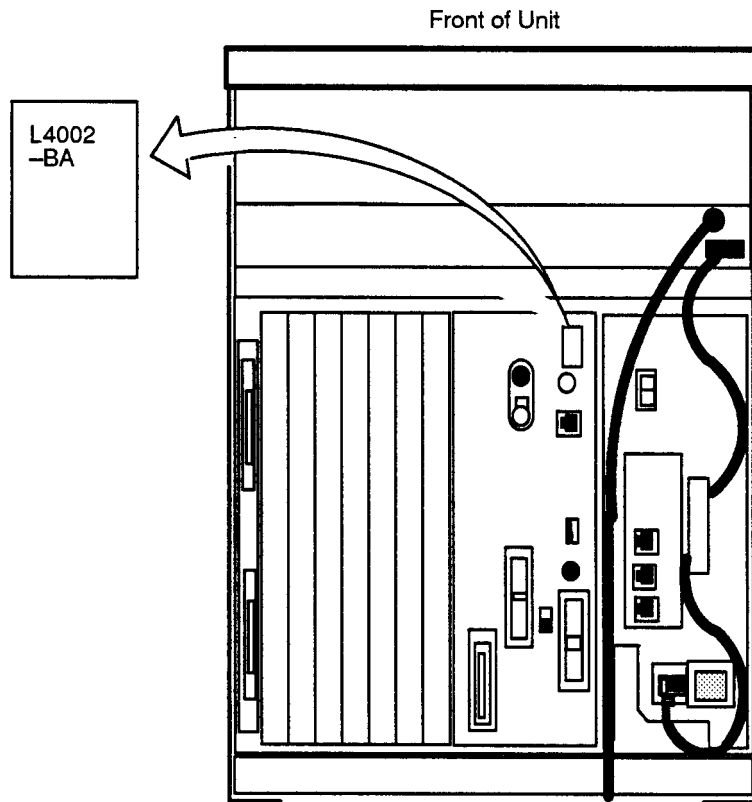

CS-8948

8. Power up the system and run the system diagnostics to verify system operation.
9. Attach the new model/serial label to the right of the existing model/serial label on the right side of the system chassis (see Figure 1-4).

10. Attach the new conversion label above the new model/serial label (see Figure 1-4).

Figure 1-4: Conversion and Serial Labels Location

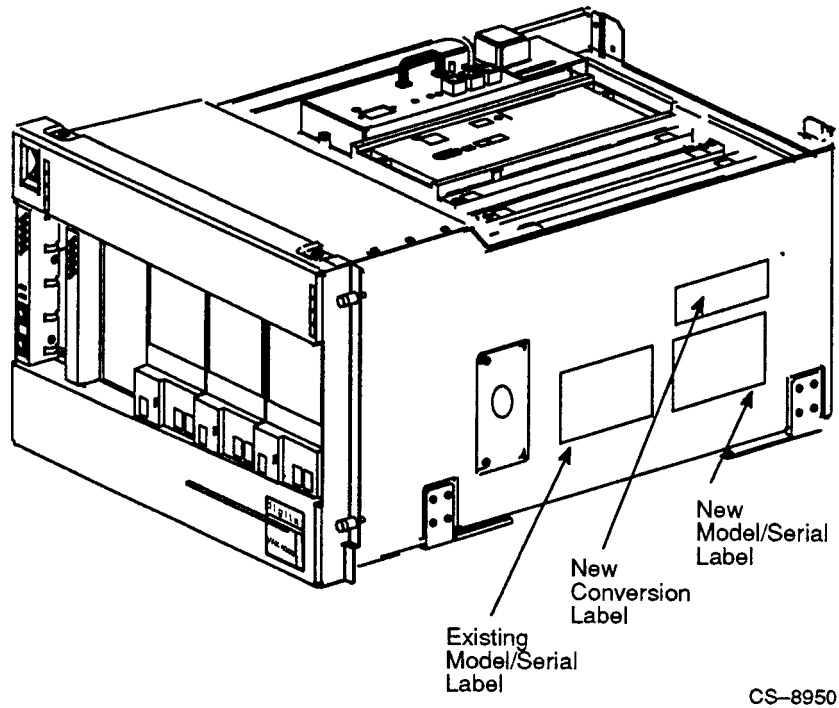

11. Remove the old medallion and color strip by using a flat-blade screwdriver to lift it off the front panel (see Figure 1-5).

Figure 1-5: Medallion Location

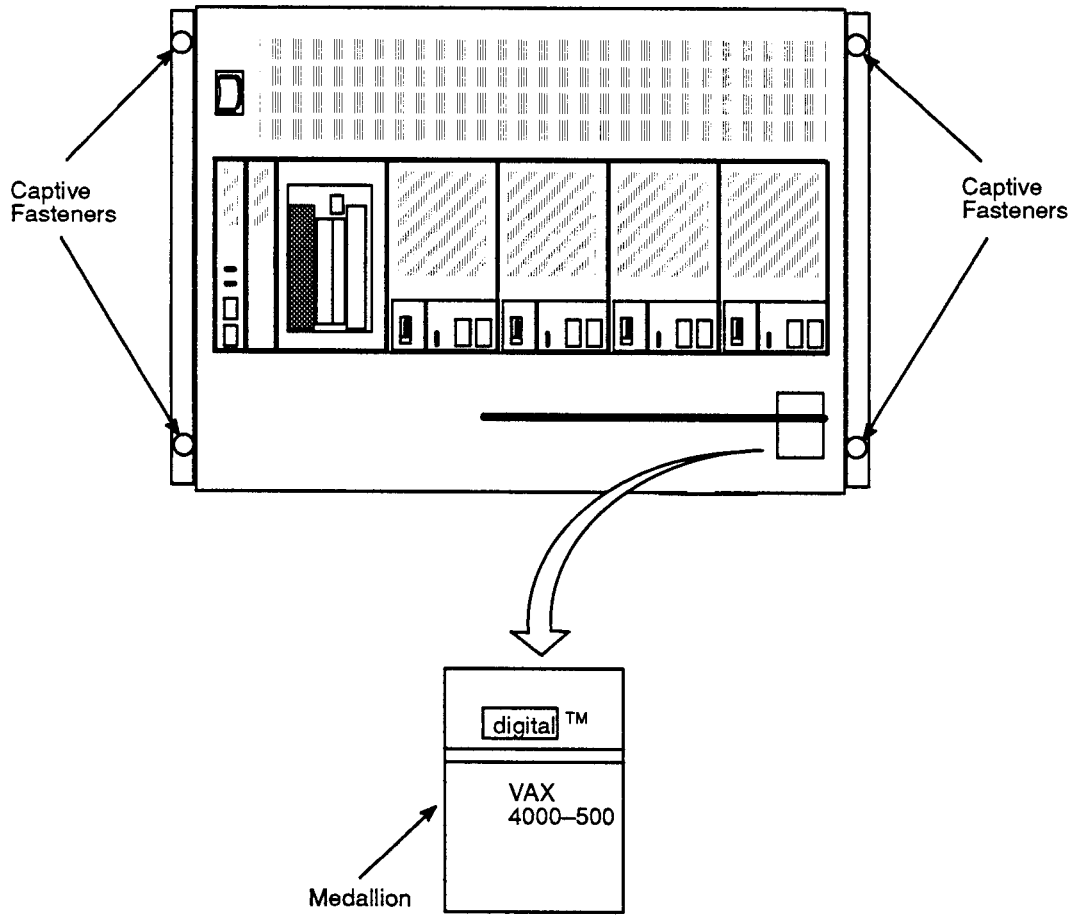

CS-8951

12. Install the new medallion.
13. Have the customer reinstall the system backup information.
14. Complete the forms in Appendix A.

1.5 Removing and Replacing the BA441 Storage Backplane

This section describes the removal and replacement procedures for the BA441 storage backplane (70-28602-02).

Removal Procedure

Perform the steps in the following procedure to remove the storage backplane assembly from the chassis:

1. Turn the main ON/OFF power switch to OFF and disconnect the power cord from the wall receptacle.
2. Release the two captive fasteners on each side of the front bezel that secure the chassis to the cabinet rails (see Figure 1-5).
3. Remove two 10-32 x 1/2 inch screws from the top of the chassis bezel.
4. Remove two 10-32 x 1/2 inch screws from the bottom of the chassis bezel.
5. Remove the chassis bezel.
6. Loosen the captive 6-32 x 3/8 inch screw securing each of the integrated storage equipment (ISE) bezels (some may be blank bezel covers).

NOTE

Be sure to note the bus identification number of each ISE before removing the cover. Each ISE device must be installed in its correct slot. Leave the cables connected to the ISE front panels to keep the appropriate ID plug with the correct ISE.

7. Remove the ISE bezels (see Figure 1-6).
8. Loosen the two captive screws that secure the ISE device to the chassis.
9. Remove all ISE devices and set aside on a clear work surface. Identify each ISE device for proper reinstalled location.
10. If a TK70 tape drive is installed, slide the device part way out and reach in through the top of the chassis and remove the control cable by pressing the two connector locking tabs. Move the cable to the rear.

11. Slide the TK70 tape drive out and set it aside on a clear work surface.

Figure 1-6: Removing the ISE Devices

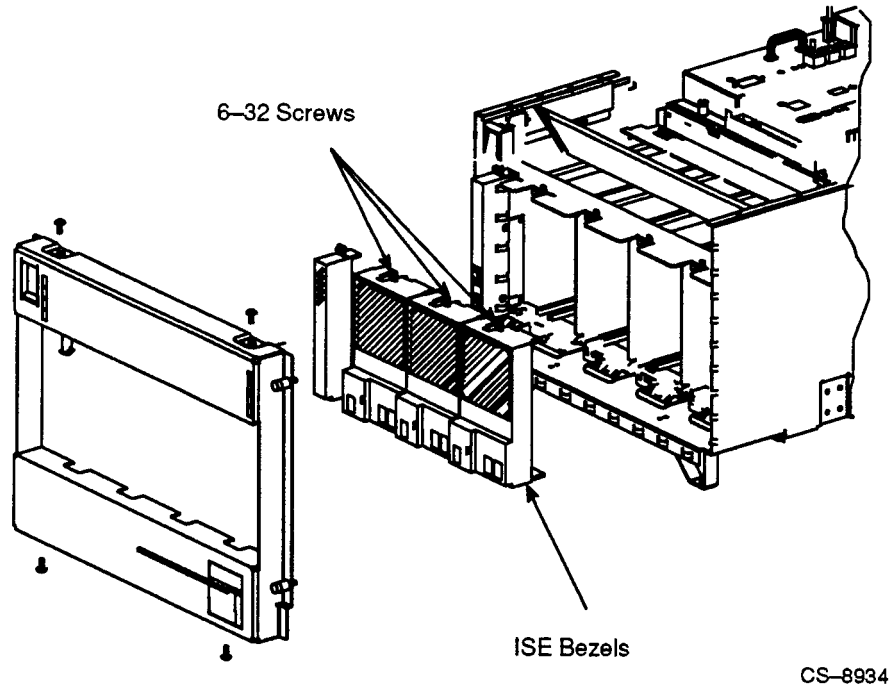

CAUTION

When removing cables from the backplane assembly, label the cables and connectors to ensure their correct replacement.

12. Remove the two DSSI and two SCSI cables from the storage backplane (see Figure 1-7).

CAUTION

When removing the storage backplane assembly, be sure that all connector extractors will not be interfering with the side of the chassis as the storage backplane is removed from the chassis.

13. Unplug the four power connectors from the storage backplane (pull the cables down and away from the storage backplane). See Figure 1-7.

Figure 1-7: Storage Backplane Assembly Showing the DSSI, SCSI and Power Connections

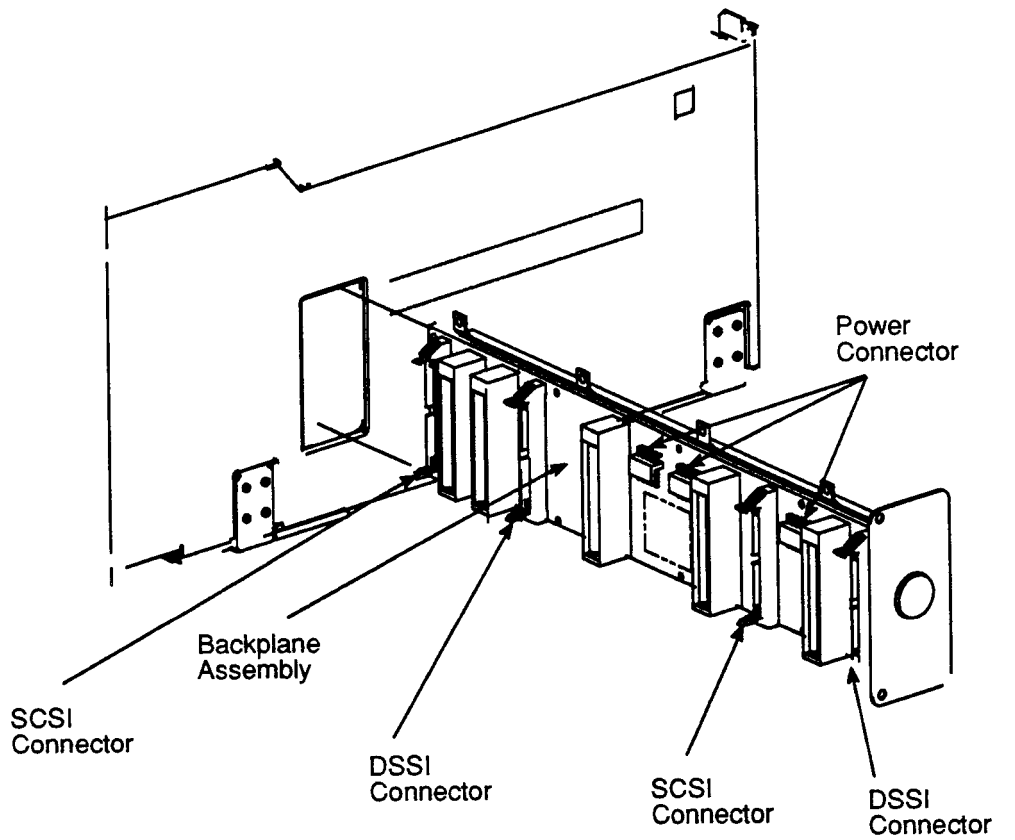

CS-8949

14. Pull the chassis forward to the lock position.
15. Remove the metal plug button from the side of the storage backplane assembly (see Figure 1-8).
16. Remove the two 6-32 x 3/8 inch screws from the storage backplane assembly cover panel.

17. Slide the storage backplane assembly through the opening in the chassis to your right (see Figure 1–8).

Replacement Procedure

To replace the storage backplane assembly, perform the reverse actions of the previous steps in reverse order.

CAUTION

When installing the storage backplane assembly, be sure that the assembly is properly aligned to the rails. Also, ensure that all connector extractors are not interfering with the side of the chassis as the assembly is pushed in place.

Figure 1-8: Backplane Assembly

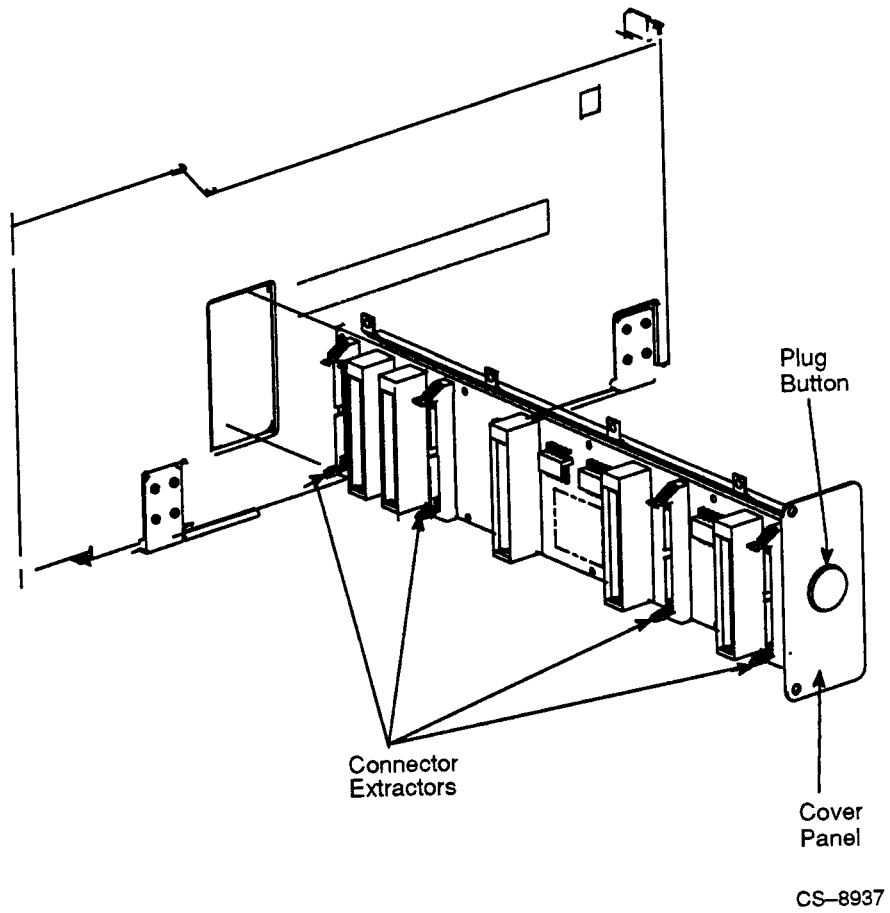

Appendix A

Mandatory Module Return Procedure and Forms

The old CPU modules need to be returned to Digital. Digital Services personnel must ensure that the instructions to repackage and return the old CPU module to Digital are followed. The instructions apply only to U.S. area installations.

For installations outside the U.S. area, contact the local Digital office for return destination instructions.

A.1 Return Procedure

1. Obtain the serial number of the system being upgraded. (Customer Administrative Services (CAS) cannot process the order without this serial number.)
2. Ensure that the serial number is on the Purchase Order.
3. Issue a hardcopy quotation to the customer, referencing the serial number, and state the following:
"Return of the replaced modules to Digital is a condition of sale for this upgrade. Failure to return the modules will result in a penalty charge. Installation of hardware by Digital Services personnel is required."
4. Pack the old modules using the packaging material set aside from the carton of the conversion kit (quad-height module box).

Pack the modules first in the nickel-plated bag, then in the pink plastic wrapping, and finally in the box.

5. Complete the Digital Services Worksheet in Section A.2. It documents the work you performed.

Return the worksheet to your contract administrator at the branch office.

6. Contact your local Digital Customer Administrative Services (CAS) office to obtain information for the Installation Receipt and the Return Material Checklist in Section A.2. Section A.3 lists the CAS district offices and their phone numbers.

Ask the CAS representative for a return authorization (RA) number. CAS will contact the customer to arrange for carrier pickup and return of the module to Digital.

7. Complete both copies of the Installation Receipt.

The first copy is the customer's receipt. It shows that the installation was completed and that Digital Services contacted CAS.

Return the second copy to Digital Services along with the old modules to ensure that the customer does not incur a penalty charge.

8. Complete the Return Material Checklist.

Return the checklist with the old modules.

9. Place the self-adhesive mailing label on the module box you are returning.

Write the return authorization (RA) number in the space provided on the label.

10. Seal the box for shipment.

Refer questions regarding the return procedure to the local account representative.

Note

Customers who do not return their old CPU modules will be charged a fee.

A.2 Digital Forms

This section contains the:

- Digital Services Worksheet
- Installation Receipt, Customer Copy
- Installation Receipt, Digital Services Copy
- Return Material Checklist

Digital Services Worksheet

This form acts as a verification of the work performed on the system and as a check on the procedures used. Please fill out this form and return it to your Contract Administrator for updating the customer's contract.

Customer: _____

System Serial Number: _____

Old System Model Number: _____

Old CPU Module Serial Number: _____

New System Name: _____

New System Model Number: _____

New CPU Module Serial Number: _____

Old Memory Modules Serial Numbers: _____

New Memory Modules Serial Numbers: _____

Installation Receipt—Customer Copy

For the conversion of Rack-Mountable VAXserver 4000-300, and Rack-Mountable VAX/VAXserver 4000-300 to 4000-500.

This form acts as a customer receipt and as verification for Digital Services that the 680XL-XX conversion kit was installed.

Digital Services: Complete both copies of this form. Then, give a copy to the customer and a copy to the local CAS office for filing with customer documents.

Customer: Digital will contact you within the next several days to arrange for package pickup and return. Keep this copy as your record of installation by Digital.

Note

Contact the local CAS office to obtain the return authorization (RA) number. See Section A.3 for the closest CAS office. You should have the Digital order number available. Be sure to note the name of the person you speak with.

Name of CAS representative: _____

Branch Office: _____ will arrange for package pickup and return.

Return Authorization (RA) Number: _____

Digital Order Number: _____

Old CPU Module Serial Number: _____

Converted to: _____

New CPU Module Serial Number: _____

Installation was performed on this date: _____

Module Packed for Return:

Customer Name: _____ Phone Number: _____

Customer Signature: _____

Digital Services Representative Signature: _____

Installation Receipt—Digital Services Copy

For the conversion of Rack-Mountable VAXserver 4000-300, and Rack-Mountable VAX/VAXserver 4000-300 to 4000-500.

This form acts as a customer receipt and as verification for Digital Services that the 680XL-XX conversion kit was installed.

Digital Services: Complete both copies of this form. Then, give a copy to the customer and a copy to the local CAS office for filing with customer documents.

Customer: Digital will contact you within the next several days to arrange for package pickup and return. Keep this copy as your record of installation by Digital.

Note

Contact the local CAS office to obtain the return authorization (RA) number. See Section A.3 for the closest CAS office. You should have the Digital order number available. Be sure to note the name of the person you speak with.

Name of CAS representative: _____

Branch Office: _____ will arrange for package pickup and return.

Return Authorization (RA) Number: _____

Digital Order Number: _____

Old CPU Module Serial Number: _____

Converted to: _____

New CPU Module Serial Number: _____

Installation was performed on this date: _____

Module Packed for Return:

Customer Name: _____ Phone Number: _____

Customer Signature: _____

Digital Services Representative Signature: _____

A-10 Mandatory Module Return Procedure and Forms

Return Material Checklist

For the conversion of Rack-Mountable VAXserver 4000-300, and Rack-Mountable VAX/VAXserver 4000-300 to 4000-500.

This form must be filled out and returned with the old modules to ensure that the customer does not incur a penalty charge.

Return Authorization (RA) Number: _____

Digital Order Number: _____

Customer Name: _____

Customer Address: _____

Customer Contact: _____

******* Include This Form With Your Module Return*******

A.3 Customer Administrative Services (CAS) District Offices

Name, Location	Phone Number
Allegheny District, Pittsburgh	(412) 244-7410
Carolinas District, Columbia	(803) 798-6477
Chicago District, Chicago	(312) 806-2478
Connecticut District, Meriden	(203) 634-5325
CSS District, Nashua	(603) 884-6549
DECdirect District, Nashua	(603) 884-9115
Florida District, Tampa	(813) 882-6822
Greater Boston District, Waltham	(617) 895-5455
Great Lakes District, Detroit	(313) 344-2285
Los Angeles District, Culver City	(213) 417-4232
Midsouth District, Memphis	(901) 761-6712
New England District, Bedford	(603) 472-6061
New Jersey Commercial District, Piscataway	(201) 562-4728
New Jersey Financial District, New York	(212) 714-2648
New York Financial District, New York	(212) 714-2648
New York Suburban District, Tarrytown	(914) 524-5284
North Central District, Minneapolis	(612) 851-2225
North Texas/Oklahoma District, Dallas	(214) 404-6135
Northwest District, Bellevue	(206) 462-2540
Ohio Valley District, Cincinnati	(513) 984-7739
Philadelphia District, Blue Bell	(215) 834-4115
Rocky Mountain District, Englewood	(303) 649-3073
Santa Clara District, Santa Clara	(408) 496-4274
Southeast District, Atlanta	(404) 257-2282

Name, Location	Phone Number
Southern California District, Costa Mesa	(714) 850-7606
South Texas District, Houston	(713) 953-3918
Southwest District, Tempe	(602) 894-4747
Upstate New York District, Rochester	(716) 385-7152
U.S. Distribution/Sales District, Marlboro	(508) 480-4259
Virginia District, Landover	(301) 306-2566
Washington DC District, Landover	(301) 459-2890
Washington DC District, FDA Landover	(301) 459-2292

Index

C

CAS district offices, A-13
Checklist, return material, A-11
Conversion kits
 unpacking 680XL, 1-2
 680XL-XX installation, 1-5

D

Digital Services worksheet, A-5
District offices, CAS, A-13

F

Forms, A-1, A-3
 Digital Services worksheet, A-5
 installation receipt, customer
 copy, A-7
 installation receipt, Digital
 Services copy, A-9
 procedure, A-1
 return material checklist, A-11

I

Installation
 680XL-XX conversion kit, 1-5
Installation receipt
 customer copy, A-7
 Digital Services copy, A-9

K

Kit Contents
 680XL-XX, 1-3

M

Mandatory Module return procedure
 and forms, A-1
Mandatory Return procedure, A-1
Material checklist, return, A-11

O

Offices, CAS district, A-13

R

Receipt, installation
 customer copy, A-7
 Digital Services copy, A-9
Return material checklist, A-11

U

Unpacking
 680XL-XX conversion kit, 1-2

W

Worksheet, Digital Services, A-5

X

680XL conversion kit

installation, 1-5

680XL-XX conversion kit

unpacking, 1-2