

**ILLUSTRATED
PARTS
BREAKDOWN**

**RX33
FLEXIBLE DISK DRIVE**

HOW TO USE THE IPB

GENERAL

This IPB is compiled following the organization and nomenclature of the engineering drawing structure.

MAJOR ASSEMBLY LOCATOR (When Applicable)

The Major Assembly Locator (first illustration) is an index that provides a description and a figure reference for all illustrations used in this manual.

INDENTED PARTS LIST

This manual identifies each assembly being broken down (figure reference callout), and all parts of that assembly. Further breakdown of an assembly is shown by an asterisk (*) preceding the item callouts in the Description Column. The number of asterisks preceding an item is used to denote the subordination of that item with respect to the Major Assembly. A single asterisk preceding an item description indicates that the item is part of the major assembly being illustrated. Items that are subordinate to single asterisks items, are denoted by two asterisks (**) and immediately follow the related single asterisk item. Additional asterisks are used, as required, to denote further subordination. This system of part identification, provides a means for the user to identify the next higher assembly item and make alternate selections for parts when the required replacement part of assembly is not immediately available.

COLUMN CALLOUT DESCRIPTION

Figure and Item - Indicates the figure number and item number of each part.

Description - Lists the name of the part and pertinent specifications (when required). Asterisks preceding the description denote the subordination of the part to the next higher assembly.

DEC Part No. - Lists the Digital part ordering number. A blank in this column indicates a Digital part number was not assigned at the time of publication.

ECO Cut-In - The notation at the top of this column indicates the ECO level of the system (option), at which the IPB was initially prepared. Subsequent ECO level designations, that modify existing parts or add new parts to the device, are inserted in the ECO Cut-In column next to the part that is added or modified.

Used On Code - Letters in this column correspond to the variation codes assigned in Figure 1. Parts with an Alpha notation(s) are used only in those option variations. A blank indicates that the part is used on all option variations.

Ref Fig No. - A cross reference between illustrations. For each Major Assembly, the number in this column denotes the figure of the next higher assembly. For all subassemblies, the number in this column denotes the figure showing additional detailed breakdown.

PART NUMBER/PART DESCRIPTION SORT SECTION

Parts are sorted both numerically and alphabetically by description, referenced to a location within the IPB, by figure number and item number.

REVISION HISTORY			DATE	OTHER IPB MANUALS REQUIRED TO SUPPORT THIS OPTION
PRINTING	ECO LEVEL			
1st Printing	RX33	00000-00000	2-Jun-86	N/A

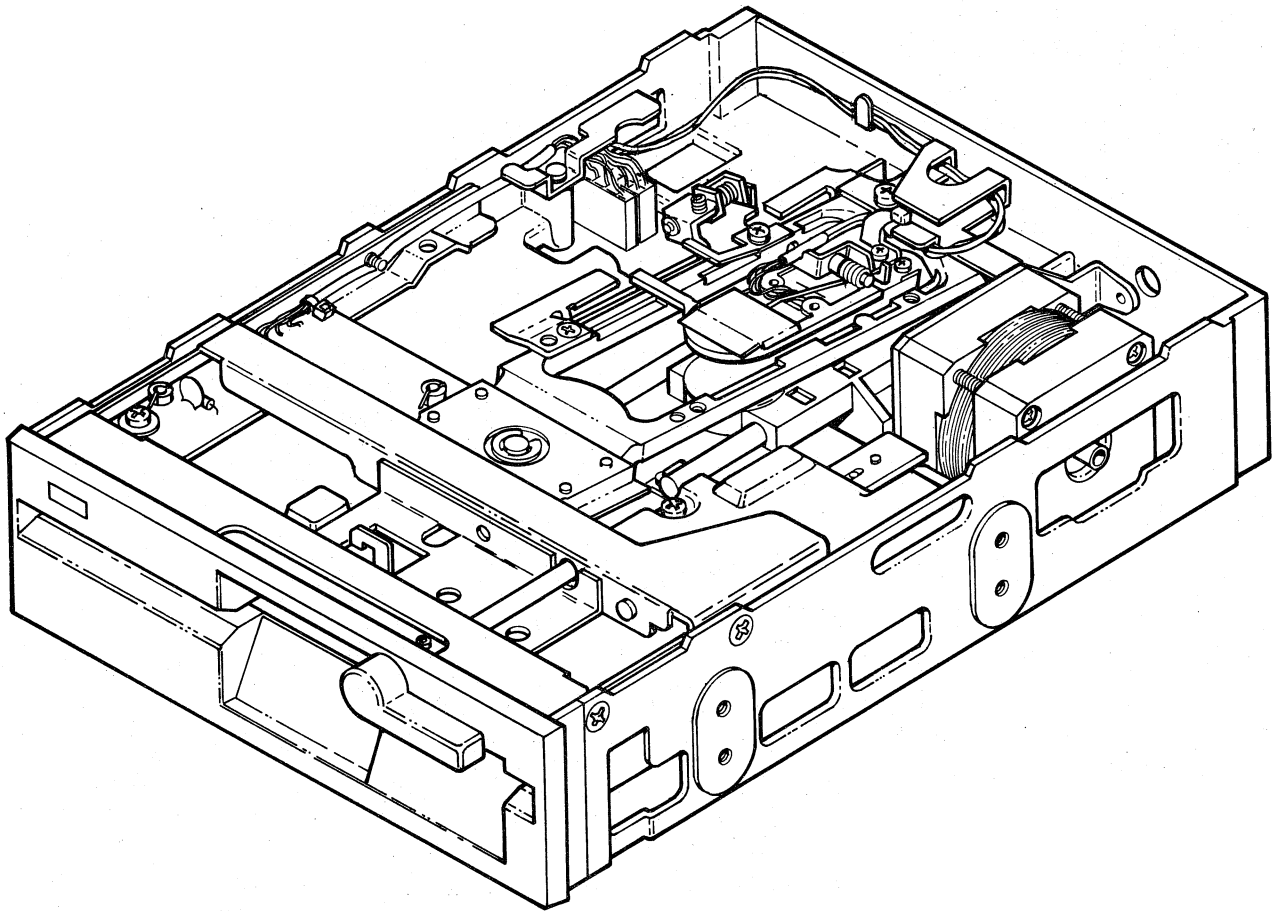

RX33-01A

Figure 1. RX33 Flexible Disk Drive Assembly (Sheet 1 of 2)

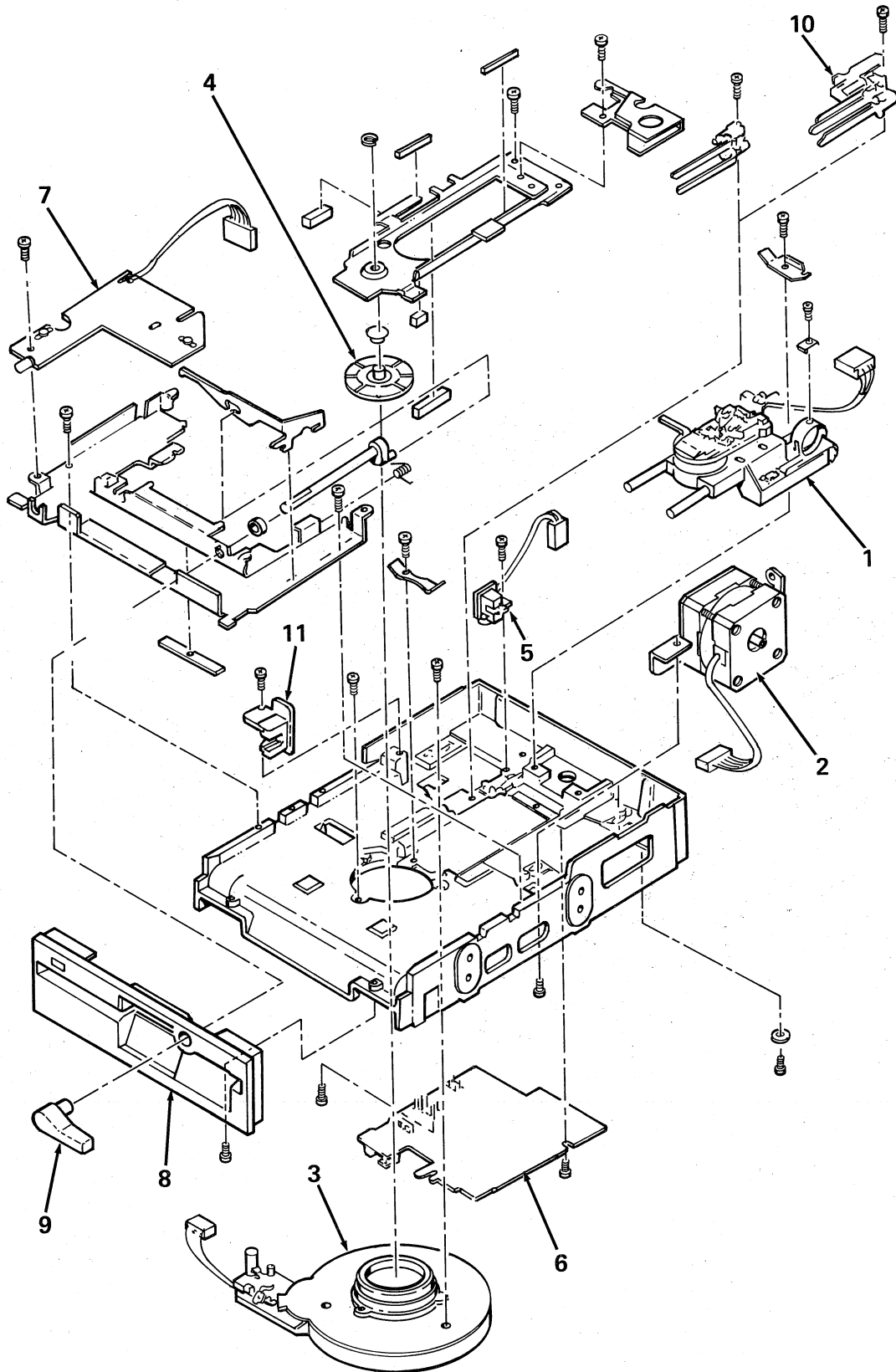

RX33-01

Figure 1. RX33 Flexible Disk Drive Assembly (Sheet 2 of 2)

FIG. & ITEM NO.	DESCRIPTION	DEC PART NO.	ECO CUT-IN RX33 00000	USED ON CODE	REF FIG NO.
1-	RX33 FLEXIBLE DISK DRIVE (30-24962-01)	RX33-00			
1	*Head Carriage Assembly	29-25987-00			
2	*Stepping Motor Assembly	29-25988-00			
3	*DD Motor Assembly	29-25989-00			
4	*Collet Assembly	29-25990-00			
5	*Too Sensor Module	29-25982-00			
6	*MFD Control Module	29-25983-00			
7	*Front OPT Module	29-25984-00			
8	*Front Bezel Assembly	29-25985-00			
9	*Front Lever Assembly	29-25986-00			
10	*CSS Assembly	29-25980-00			
11	*Disk Sensor Module	29-25981-00			

**ILLUSTRATED PARTS BREAKDOWN
COMMENT SHEET**

Any and all comments and suggestions for correcting errors and/or additional information to improve this manual will be reviewed and researched for possible use when this manual is revised and/or reprinted. Enter your comments and suggestions in the form provided below and return to Technical Documentation.

MODEL RX33 FLEXIBLE DISK DRIVE

PUBLICATION NO. EK-ORX33-IP-001

FIGURE NO. _____ ITEM NO. _____
CHANGE FROM _____
CHANGE TO _____

FIGURE NO. _____ ITEM NO. _____
CHANGE FROM _____
CHANGE TO _____

FIGURE NO. _____ ITEM NO. _____
CHANGE FROM _____
CHANGE TO _____

FIGURE NO. _____ ITEM NO. _____
CHANGE FROM _____
CHANGE TO _____

FIGURE NO. _____ ITEM NO. _____
CHANGE FROM _____
CHANGE TO _____

FIGURE NO. _____ ITEM NO. _____
CHANGE FROM _____
CHANGE TO _____

ADDITIONAL COMMENT(S)

Please describe your position. _____

Name _____ Organization _____

Street _____ Department _____

City _____ State _____ Zip or Country _____

Fold Here-----

Do Not Tear - Fold Here and Staple-----

digital



No Postage
Necessary
if Mailed in the
United States

BUSINESS REPLY MAIL

FIRST CLASS PERMIT NO. 33 MAYNARD, MA

POSTAGE WILL BE PAID BY ADDRESSEE

Digital Equipment Corporation
Educational Services
129 Parker Street, PK03-2/H31
Maynard, MA 01754

