

# LOP8/78 Printer Systems Technical Manual

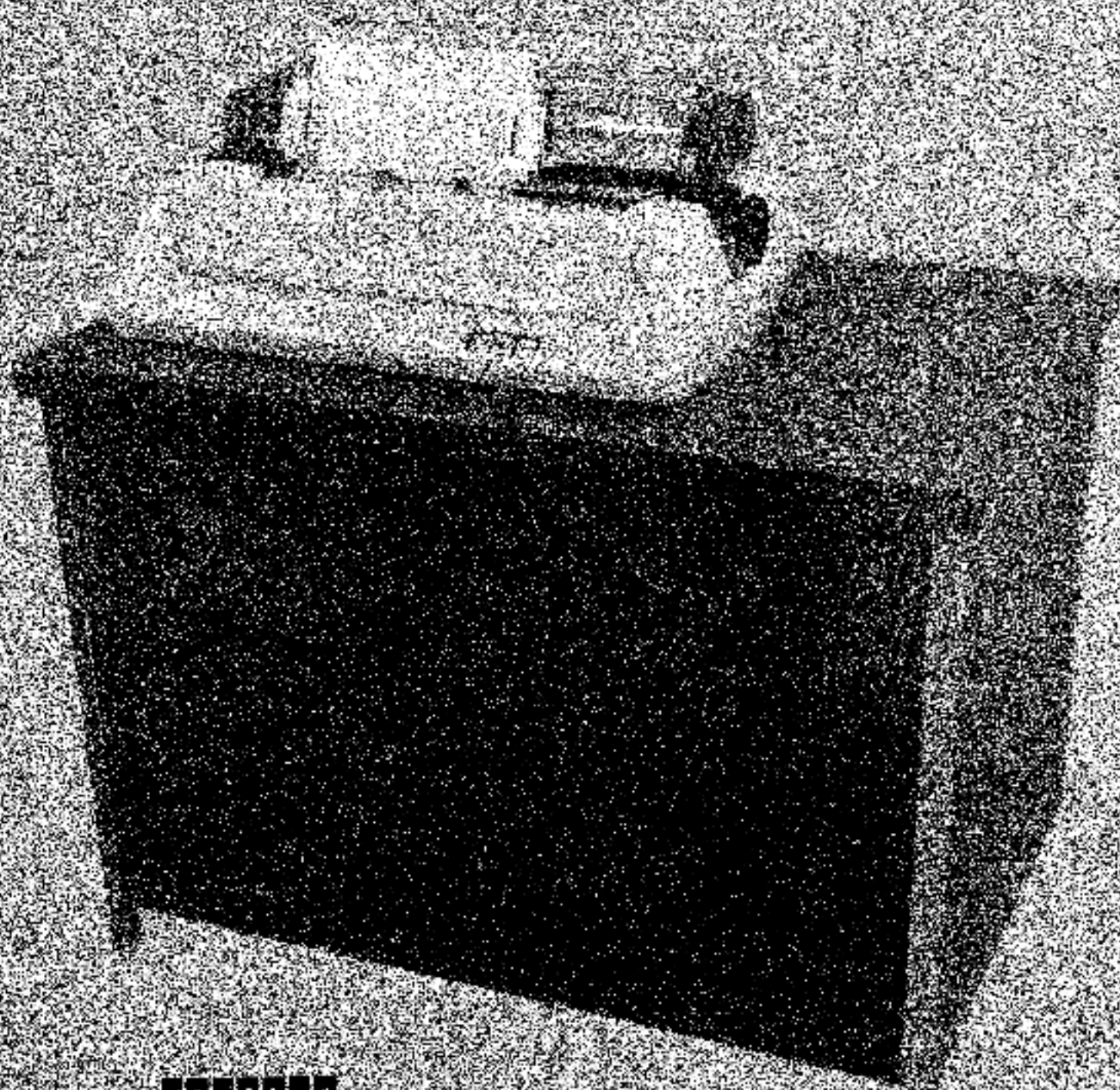

300000



# **LQP8/78 Printer Systems Technical Manual**

## **CAUTION**

The carriage assembly removal/replacement procedures in this manual supersede all previous printings of this manual.

1st Edition, June 1976  
2nd Edition, February 1977  
3rd Edition, September 1977  
3rd Edition (Rev), June 1980

Copyright © 1976, 1977, 1980 by Digital Equipment Corporation

The material in this manual is for informational purposes and is subject to change without notice.

Digital Equipment Corporation assumes no responsibility for any errors which may appear in this manual.

Printed in U.S.A.

This document was set on DIGITAL's DECset-4000 computerized typesetting system.

The following are trademarks of Digital Equipment Corporation, Maynard, Massachusetts:

DEC	DECtape	PDP
DECMM	DECUS	RSTS
DECsystem-10	DIGITAL	TYPESET-8
DECSYSTEM-20	MASSBUS	TYPESET-11
		UNIBUS

# CONTENTS

		Page
<b>CHAPTER 1</b>	<b>DESCRIPTION</b>	
1.1	INTRODUCTION	1-1
1.2	EQUIPMENT SUPPLIED	1-1
1.3	PHYSICAL DESCRIPTION	1-3
1.3.1	Printer Assembly	1-3
1.3.2	Printer Power Supply	1-5
1.3.3	IQPS-E Controller	1-5
1.3.4	BC03R Signal Cable	1-5
1.3.5	BC80F-25 Interface Cable	1-5
1.4	APPLICABLE DOCUMENTS	1-7
1.5	PERFORMANCE SPECIFICATIONS	1-7
<b>CHAPTER 2</b>	<b>INSTALLATION AND CHECKOUT GUIDE</b>	
2.1	GENERAL	2-1
2.2	UNPACKING AND INSPECTION	2-2
2.3	INSTALLING THE CONTROLLER MODULE	2-2
2.4	INSTALLING THE BC03R SIGNAL CABLE	2-4
2.5	PAPER INSTALLATION/ALIGNMENT (Without Forms Tractor)	2-9
2.6	PRINT DENSITY ADJUSTMENT	2-10
2.7	PRE-OPERATIONAL CHECKOUT	2-10
<b>CHAPTER 3</b>	<b>OPERATION</b>	
3.1	GENERAL	3-1
3.2	OPERATING CONTROLS AND INDICATORS	3-1
3.3	LOADING PAPER	3-1
3.3.1	Using Paper Guide Cradle	3-1
3.3.2	Using Forms Tractor	3-4
3.4	CHANGING RIBBONS	3-11
3.5	CHANGING PRINT WHEELS	3-11
3.6	ENERGIZING THE PRINTER ASSEMBLY	3-15
3.7	NORMAL OPERATING PROCEDURE	3-15
3.8	OPERATOR MAINTENANCE	3-16
3.9	FORMS TRACTOR REMOVAL	3-16
3.10	SKIRT AND PLATEN REMOVAL	3-16
3.11	PAPER GUIDE CRADLE REMOVAL/INSTALLATION	3-17
3.12	PLATEN AND SKIRT INSTALLATION	3-19
3.13	EMERGENCY OPERATION	3-21
3.14	DE-ENERGIZING THE PRINTER ASSEMBLY	3-21
<b>CHAPTER 4</b>	<b>PROGRAMMING</b>	
4.1	GENERAL	4-1
4.2	CONTROLLER INTERFACE SIGNALS	4-1
4.3	IOU INSTRUCTIONS	4-4
4.4	PROGRAMMING CONSIDERATIONS	4-10
4.5	PROGRAMMING EXAMPLES	4-11

## CONTENTS (CONT)

		Page
<b>CHAPTER 5</b>	<b>TECHNICAL DESCRIPTION</b>	
5.1	INTRODUCTION . . . . .	5-1
5.2	GENERAL INFORMATION . . . . .	5-1
5.2.1	Logic Diagrams . . . . .	5-1
5.2.2	IC Complement . . . . .	5-1
5.2.3	Printer Interface Signals . . . . .	5-1
5.2.4	Omnibus Interface Signals . . . . .	5-4
5.2.5	PDP-8 Word Structure . . . . .	5-4
5.3	DETAILED THEORY . . . . .	5-5
5.3.1	Basic Printer Operation . . . . .	5-5
5.3.2	Restore Printer and Clear DONE Flag (IOT 6507) . . . . .	5-5
5.3.3	Read Status Register (IOT 6505) . . . . .	5-7
5.3.4	Write Status (IOT 6506) . . . . .	5-7
5.3.5	Print Character (IOT 6504) . . . . .	5-8
5.3.6	Move Carriage (IOT 6503) . . . . .	5-9
5.3.7	Move Paper (IOT 6502) . . . . .	5-10
5.3.8	Read Data Buffer into Accumulator (IOT 6501) . . . . .	5-10
5.3.9	Skip on Done (IOT 6500) . . . . .	5-10
<b>CHAPTER 6</b>	<b>SERVICE</b>	
6.1	INTRODUCTION . . . . .	6-1
6.1.1	Scope . . . . .	6-1
6.1.2	Maintenance Plan . . . . .	6-1
6.1.3	Resources . . . . .	6-1
6.2	PREVENTIVE MAINTENANCE . . . . .	6-2
6.2.1	Preventive Maintenance Schedule . . . . .	6-2
6.2.2	Materials Required . . . . .	6-2
6.2.3	Customer Performed Equipment Maintenance . . . . .	6-2
6.2.4	Field Service Preventive Maintenance . . . . .	6-2
6.2.4.1	Inspection . . . . .	6-2
6.2.4.2	Cleaning . . . . .	6-2
6.2.4.3	Lubrication . . . . .	6-3
6.3	DIAGNOSTIC FUNCTIONAL DESCRIPTION . . . . .	6-6
6.3.1	Overall Performance Test . . . . .	6-6
6.3.1.1	Controller Diagnostic Test . . . . .	6-6
6.3.1.2	Printer Dynamic Diagnostic Tests . . . . .	6-6
6.3.1.3	Diagnostic Load and Run Procedure . . . . .	6-7
6.3.1.4	Manual Entry of Characters for Printing . . . . .	6-8
6.3.1.5	Halting an In-Process Dynamic Diagnostic Test . . . . .	6-8
6.3.1.6	Restarting Dynamic Diagnostic After Halt . . . . .	6-8
6.3.1.7	Procedure for Modifying the Contents of a Location . . . . .	6-8
6.4	FUNCTIONAL SECTION FAULT ISOLATION . . . . .	6-9
6.4.1	Specific Tests and Descriptions . . . . .	6-9
6.4.2	Fault Isolation . . . . .	6-9
6.5	TROUBLESHOOTING . . . . .	6-9
6.5.1	Initial Analysis . . . . .	6-9
6.5.2	Alignment and Adjustment . . . . .	6-11

## CONTENTS (CONT)

		Page
6.5.2.1	Print Wheel to Hammer Adjustment.....	6-13
6.5.2.2	Platen to Print Wheel Alignment Procedure.....	6-14
6.5.2.3	Card Guide Height and Position Adjustment.....	6-16
6.5.2.4	Ribbon Height Adjustment.....	6-17
6.5.2.5	Carriage Home Adjustment.....	6-19
6.5.2.6	Hammer Armature Gap Adjustments.....	6-20
6.5.2.7	Platen Height Adjustment.....	6-20
6.5.2.8	Paper Feed Adjustment.....	6-34
6.5.2.9	Print Wheel Home Sensor (Transducer) Alignment.....	6-35
6.5.3	Removal and Replacement.....	6-34
6.5.3.1	Carriage Removal Procedure.....	6-37
6.5.3.2	Carriage Replacement Procedure.....	6-52
<b>APPENDIX A</b>	<b>MODIFIED ASCII CODE FOR STANDARD PRINT WHEEL</b>	
<b>APPENDIX B</b>	<b>POSITION OF CHARACTERS ON PRINT WHEEL</b>	
<b>APPENDIX C</b>	<b>INTERFACE WIRING DETAILS</b>	
<b>APPENDIX D</b>	<b>DETAILS OF INTEGRATED CIRCUITS ON LQP8-E CONTROLLER</b>	
<b>APPENDIX E</b>	<b>TROUBLESHOOTING FLOWCHART</b>	
<b>APPENDIX F</b>	<b>LQP8-F SERIAL PRINTER</b>	
F.1	SCOPE.....	F-1
F.2	INTRODUCTION.....	F-1
F.2.1	Equipment Supplied.....	F-1
F.2.2	Physical Description.....	F-2
F.2.3	General Specifications.....	F-3
F.2.4	Applicable Documents.....	F-4
F.3	PREOPERATIONAL CHECKOUT.....	F-4
F.4	FUNCTIONAL DESCRIPTION.....	F-5
F.5	SERVICING.....	F-5
F.5.1	General.....	F-5
F.5.2	Maintenance Plan.....	F-6
F.5.3	FRU, Spares and Tools.....	F-6
F.5.4	Diagnostics.....	F-7
F.5.5	Troubleshooting.....	F-7
F.5.6	Module Removal and Replacement.....	F-8
F.6	INTERFACE WIRING DETAILS.....	F-8

## FIGURES

Figure No.	Title	Page
1-1	Typical LQP8 Printer System .....	1-2
1-2	LQP01 Printer Without Forms Tractor .....	1-6
2-1	Site Considerations for LQP8 Printer and Desk .....	2-1
2-2	Packaging of LQP8 Printer System .....	2-3
2-3	Jumper Wires on LQP8-E Controller Module .....	2-4
2-4	Raising Printer Access Cover .....	2-5
2-5	View Showing Top Cover Release Lever .....	2-6
2-6	View Showing Power and Signal Cable Connections .....	2-7
2-7	Interconnection Diagram for Typical LQP8 Printer System .....	2-8
2-8	Paper Alignment Holes .....	2-9
3-1	Forms Tractor Clamp Assembly .....	3-5
3-2	Forms Tractor Installation .....	3-6
3-3	Positioning of Platen Pressure Release Lever When Forms Tractor Is Installed .....	3-7
3-4	Major Elements of Forms Tractor .....	3-8
3-5	Loading Paper Through Slot in Desk Top .....	3-9
3-6	Loading Paper in Forms Tractor from Rear .....	3-10
3-7	Ribbon Removal .....	3-12
3-8	Inner Carriage Assembly Tilted Away from Platen .....	3-13
3-9	View Showing Print Wheel Motor Shaft and Print Wheel Alignment Hole .....	3-14
3-10	Skirt Removal .....	3-17
3-11	Pressing Platen Latches .....	3-18
3-12	View Showing Paper Guide Cradle .....	3-19
3-13	Readying Platen for Installation .....	3-20
3-14	Platen Installed .....	3-21
4-1	Controller Interface Signals .....	4-2
4-2	LQPSR Bit Interpretation .....	4-2
4-3	IOT Instruction Format .....	4-4
4-4	Programming Paper Motion .....	4-8
4-5	Programming Carriage Motion .....	4-9
4-6	Programming Printer Commands .....	4-10
4-7	Programming Example No. 1 .....	4-11
4-8	Programming Example No. 2 .....	4-13
5-1	Controller Block Diagram .....	5-2
5-2	Waveforms for IOT 6507 (Restore Function) .....	5-6
5-3	Waveforms for IOT 6505 (Read Status) .....	5-7
5-4	Waveforms for IOT 6506 (Load Status) .....	5-8
5-5	Waveforms for IOT 6504 (Print Character) .....	5-9
5-6	Waveforms for IOT 6503 (Carriage Motion) .....	5-10
5-7	Waveforms for IOT 6502 (Paper Motion) .....	5-11
6-1	Carriage System Lubrication Points .....	6-4
6-2	Carrier System Lubrication Points .....	6-5
6-3	Platen Lubrication Points .....	6-6
6-4	Printed Circuit Board Layout and Function Description .....	6-12
6-5	Multipurpose Alignment Tool .....	6-13
6-6	Print Wheel-to-Hammer Alignment Positions .....	6-14
6-7	Platen-to-Print Wheel Adjustment .....	6-15
6-8	Card Guide Height Adjustment .....	6-16

## FIGURES (CONT)

Figure No.	Title	Page
6-9	Ribbon Height Adjustment.....	6-18
6-10	Exploded View of Ribbon Lift Assembly.....	6-19
6-11	Carriage Home Adjustment.....	6-20
6-12	Hammer Gap Adjustments.....	6-21
6-13	Eccentrics for Adjusting Platen Height.....	6-21
6-14	Paper Feed Adjusting Hardware.....	6-34
6-15	Exploded View of Carriage Assembly.....	6-36
6-16	Printer Showing Cover and Signal Cable Removed.....	6-39
6-17	Printer Tilted on Back.....	6-40
6-18	Printer Showing Bottom Panel Removed.....	6-41
6-19	Bottom View Showing Connectors, Cables, Tie Wraps, and Attaching Hardware.....	6-42
6-20	Bottom View Showing Connectors Removed.....	6-43
6-21	Bottom View Showing Bottom Plate Removed.....	6-44
6-22	Bottom View Showing Carriage Assembly Positioned for Carriage Assembly Pulley Access.....	6-45
6-23	View Showing Pulley Hold-Down Screw.....	6-46
6-24	View Showing Carriage Assembly Bottom Pulley with Hold-Down Screw Removed.....	6-47
6-25	View Showing Slide Rail Hold-Down Screws.....	6-48
6-26	View Showing Top Slide Rail Disengaged from Clamp.....	6-49
6-27	View Showing Top Slide Rail Disengaged from Carriage Assembly.....	6-50
6-28	View Showing Bottom Slide Rail Disengaged from Clamp and Rubber Bushing Removed.....	6-51
6-29	View Showing Carriage Assembly Removed from Slide Rails.....	6-52
A-1	Modified ASCII Example.....	A-2
B-1	Print Wheel Characters.....	B-1
C-1	Interconnection Diagram for Typical LQP8 Printer System.....	C-2
E-1	LQP8 Troubleshooting Flowchart.....	E-3
F-1	LQPXX-CS Serial Interface Components.....	F-2
F-2	LQPXX-CS Cable Connection Diagram.....	F-3
F-3	Mother Board Switch Settings.....	F-5
F-4	Functional Block Diagram.....	F-6
F-5	Self-Test Functional Test Printout.....	F-9

## TABLES

Table No.	Title	Page
1-1	LQP8 Printer Systems.....	1-1
1-2	Equipment Supplied.....	1-3
1-3	Standard Print Wheel Fonts Available from DIGITAL.....	1-3
1-4	Special Order Print Wheels.....	1-4
1-5	Applicable Documents.....	1-7
1-6	LQP8 Performance Specifications.....	1-9
3-1	Operating Controls and Indicators.....	3-2

## TABLES (CONT)

Table No.	Title	Page
3-2	Operator Maintenance Chart.....	3-16
4-1	Bit Description for LQPSR.....	4-3
4-2	Functional Description of I/O Instructions.....	4-5
5-1	Controller IC Complement.....	5-1
5-2	Printer Interface Signals.....	5-3
6-1	Recommended LQP8 Field Service Branch Spares.....	6-1
6-2	Catastrophic Failure Troubleshooting Chart.....	6-10
6-3	Degraded Print Quality Troubleshooting Chart.....	6-22
C-1	Pin Assignments on LQP8-E Controller Module Connector J1.....	C-3
C-2	Pin Assignments on Power Supply Connector P4.....	C-4
E-1	LQP8 System Problems.....	E-1
F-1	Equipment Supplied with the LQPXX-CS.....	F-1
F-2	Recommended FRU Spares and Tools for the LQPXX-CS.....	F-7

## CHAPTER 1 DESCRIPTION

### 1.1 INTRODUCTION

This manual contains both user and field service information for the LQP8 Printer System. Each system is comprised of: an LQP01 serial printer (with forms tractor), an LQP8-E controller, a power supply, an enclosed metal desk, signal cabling, and accessories (Figure 1-1).

The LQP8/78 (i.e., LQP78) printer is interfaced to the VT78 DECstation processor-display unit via the BC80F-25 interface cable. Unlike other versions of the LQP8 systems, the LQP8/78 printer does not contain a controller. Other than these differences, both printer systems are identical in operation and performance.

The LQP8 Printer System is designed primarily for use with the PDP-8 family of positive bus computers. The LQP8 uses a lightweight, plastic print wheel as the basic printing mechanism for high-quality alphanumeric and graphic reproduction. The printer is capable of obtaining a print speed of up to 45 characters per second.

There is no keyboard on the LQP01 printer. In a normal word processing application, messages are typed on a separate keyboard for display and subsequent editing on a video terminal. The edited message is then transmitted from the word processor memory to the LQP01 for hard copy printouts.

Table 1-1 lists the model designations for the LQP8 Printer Systems. Models LQP8-EA and LQP8-EB are identical except for the wiring of the input power transformer in the power supply. Model LQP8-EA operates on 115 Vac, 50 or 60 Hz; Model LQP8-EB operates on 230 Vac, 50 or 60 Hz. The power supply is prewired at the factory (prior to shipment) for either 115 or 230 Vac operation.

Table 1-1 LQP8 Printer Systems

Model	Consists Of	Input Power
LQP8-EA	LQP01-A Printer, Power Supply and Desk LQP8-E Controller (M8366 plus BC03R-25)	115 Vac, 50 or 60 Hz
LQP8-EB	LQP01-B Printer, Power Supply and Desk LQP8-E Controller (M8366 plus BC03R-25)	230 Vac, 50 or 60 Hz

### 1.2 EQUIPMENT SUPPLIED

Table 1-2 lists the quantity and DIGITAL part number for each item supplied with the LQP8.

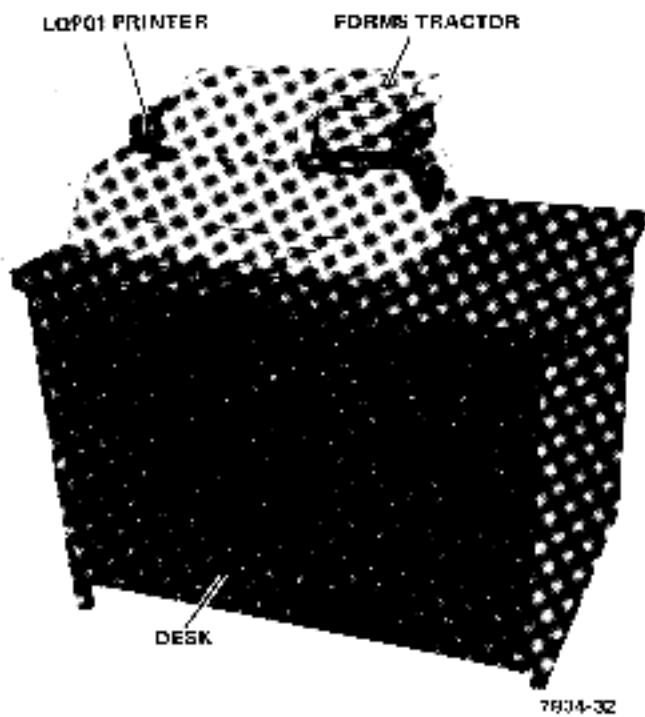

7834-23  
TYPICAL PRINT WHEEL



7834-1  
BC03R FLAT SIGNAL CABLE



7834-3  
AC/DC POWER SUPPLY

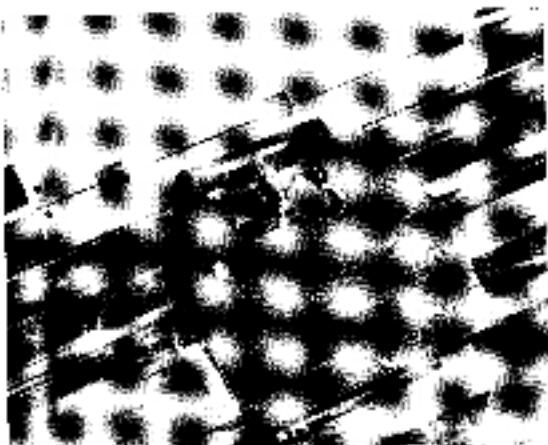

7834-5  
RIBBON CARTRIDGE

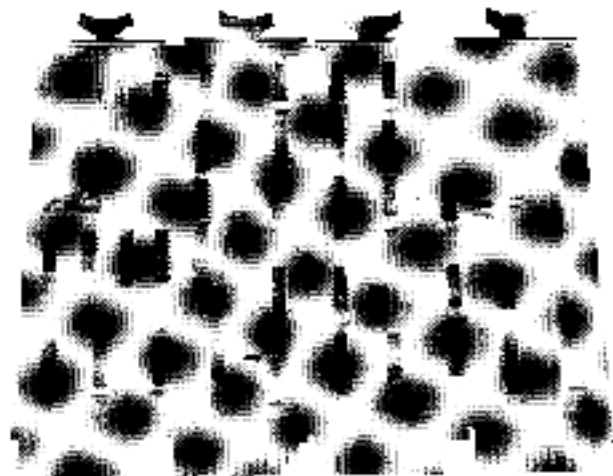

7834-30  
LQP0-E INTERFACE CONTROLLER

Figure 1-1 Typical LQP0 Printer System

**Table 1-2 Equipment Supplied**

Quantity	Name	DIGITAL Part No.
1 each	Printer	30-13086-00
1 each	Forms Tractor	30-13087-00
1 each	Power Supply	30-13094-00
1 each	Desk	34-13093-00
1 each	Controller	LQP8-E
1 each	I/O Cable	BC03R-0-0
1 stack	Paper, Fanfold, 15-in Wide	----
1 each	Print Wheel (Courier 72)	36-13256-04
1 each	Ribbon Cartridge, Cloth, Black	36-13259-02
1 each	Ribbon Cartridge, Mylar, Black	36-13259-01

### 1.3 PHYSICAL DESCRIPTION

#### 1.3.1 Printer Assembly

The model (LQP01) printer is a modified Diablo Model 1345 HyType II Serial Impact Printer\*. It is a rugged, compact unit featuring multiple-forms capability, letter quality printing, and minimum maintenance. Unique machine design features eliminate most of the moving parts that are found in conventional stand-alone printers.

The printer uses a 96-character set printing element in either 10 or 12 pitch. Horizontal column spacing is in increments of 1/120th of an inch (120 positions per inch), and vertical line spacing is in increments of 1/48th of an inch (48 print positions per inch).

The typing ribbon is completely enclosed in a durable, non-smudge cartridge-type holder; it also snaps easily in and out of place for easy replacement.

Single-color cloth ribbons (approximately 1 million impressions) and mylar ribbons (approximately 200,000 impressions) are standard DIGITAL accessories. Cloth ribbons are continuous loop, mylar ribbons have an end-of-ribbon sensor to stop the printer when the sensor is activated.

The inner carriage assembly tilts away from the platen for easy access and exchange of print wheels. There are four print wheels that are standard DIGITAL accessories (Table 1-3). Table 1-4 lists the print wheels that are available on request. The 7-bit modified ASCII code (in octal) for programming the print wheel characters is detailed in Appendix A.

\*Diablo Systems, Inc., Hayward, California 94545

**Table 1-3 Standard Print Wheel Fonts Available from DIGITAL**

Font	Pitch	DIGITAL Part No.
Courier 10	10	36-13256-01
Pica 10	10	36-13256-02
Elite 12	12	36-13256-03
Courier 72	10	36-13256-04

**Table 1-4 Special Order Print Wheels\***

Font Style	Pitch	Font Style	Pitch
APL 10	10	Kana Gothic Pica 10	10
British Pica 10	10	Manifold 10	10
Courier Legal 10	10	OCR-A	10
Courier Legal 10A	10	OCR-B	10
Forms Gothic S-10	10	OCR-B Kana	10
French Prestige Cubic	10	Pica Legal 10A	10
General Scientific 10	10	Prestige Elite Legal 12	12
German Pica 10	10	Scandin Elite 12	12
Kana Gothic Elite 12	12	UK Courier 10	10

\*Available upon request.

Contact your DIGITAL/Diablo Sales Representative for samples of these print styles, or information on unlisted print wheels.

Each print wheel is 7.62 cm (3 in) in diameter and resembles a daisy with 96 petals, one for each character. All of the standard print wheels are directly interchangeable and easily snap in and out of place in a matter of seconds.

The letter E is the home position for the print wheel; that is, E is the starting position of the wheel when the printer is initialized (restored). The print wheel control logic computes the shortest distance and direction of movement to place the next character to be printed in front of the print hammer. On receipt of the first character, the print wheel rotates up to 3.14100 radians (180 degrees) in either direction, depending on the selected character location, and then stops. The print hammer hits the petal, with the result that the character is printed on the paper. On receipt of the next character, the print wheel moves up to 3.14100 radians (180 degrees) in either direction from the first character position and the printing process continues.

Print wheel velocity is a function of the distance to be traveled, with the wheel stopping prior to each print hammer stroke. A 3-position hammer-intensity switch (under the access cover) permits manual adjustment for variable font size and multiple-forms requirements.

Carriage movement permits printing in either direction (left-to-right or right-to-left) along the horizontal axis with equal speed and ease. By printing in the reverse direction, a carriage return is avoided, resulting in a 15 percent increase in speed. With power off, the carriage can be moved manually along the platen. When power is applied and the printer is initialized, the carriage automatically returns to its leftmost (home) position.

Paper feed is controlled by a friction-fed platen that can be used with or without the forms tractor option. If the forms tractor option is not used, a paper guide cradle is installed. In this configuration, paper is loaded from the top side of the printer, around the platen. Paper movement can be forward (upward) or backward (downward). Note that if the forms tractor option is installed, downward motion is not possible. A platen position control lever provides the operator with the ability to adjust for paper thickness and/or multiple forms.

When the forms tractor option is used, the paper guide cradle must be removed to facilitate installation. In this configuration, fanfold paper is loaded from the bottom of the printer, through a slot in the desk, and onto the forms tractor. In this case, paper movement can only be in the forward (upward) direction. The forms tractor accommodates single-sheet or multiple-form paper (up to six parts) with standard 1.27 cm (1/2 in) hole spacing. The forms tractor option is mounted on top of the printer and is driven by the paper feed drive train. The tractor is adjustable to any form from 4.45 cm (1-3/4 in) to 38.10 cm (15 in) wide.

The operator control panel (Figure 1-2) contains two status indicators (PRINTER READY and END OF RIBBON) and one pushbutton switch (PAUSE). When lit, PRINTER READY indicates the printer is on-line and ready for printing. END OF RIBBON lights when the mylar ribbon is exhausted. Pressing the PAUSE pushbutton lights the PAUSE lamp and causes the printer to complete all commands currently in process and then stop. This feature permits the operator to change print wheels or to service exhaustible supplies such as ribbon and paper without having to power down the system. When service is completed, the PAUSE pushbutton is pressed to extinguish the PAUSE lamp and permit normal print operations to be resumed without losing any information.

Additional operator controls shown in Figure 1-2 include: left and right bail arms for moving the paper bail forward or backward; a platen pressure release lever for paper positioning and line-up; and a platen position control lever for multiple-copy control. The right-hand platen knob can be pushed in and adjusted for fine vertical paper movement.

Printer electronics and cable connections are located at the rear of the printer, below the ventilated cover.

A paper guide rack assembly is permanently attached to the printer cover assembly (Figure 1-2). Two other rack assemblies (upper and lower) are added to the printer when the forms tractor option is installed (not shown). The rack assemblies facilitate better air circulation over the printer electronics and also guide the paper properly to prevent paper jams.

### 1.3.2 Printer Power Supply

The printer power supply is a Diablo Model 1329 regulated supply, which is a self-contained unit that measures 45.72 cm (18 in) long by 20.73 cm (8.16 in) wide by 8.31 cm (3.27 in) high (approximate dimensions). The power supply is mounted in a metal enclosure inside the desk. An ac power cable on the front of the supply connects the power supply to the main power source. An output power cable on the rear of the supply connects the power supply to a 14-pin connector on the right rear side of the printer. There are no power on-off indicators or switches on the supply. However, an external circuit breaker is provided on the power control box inside the desk. Output dc voltages from the power supply are:  $\pm 15$  Vdc and +5 Vdc.

### 1.3.3 LQP8-E Controller

The interface controller is a single M8366 quad module with TTL logic. It is installed on the PDP-8 Omnibus and connected to the LQP01 printer via a 50-conductor BC03R-25 flat cable. There are two jumper selectable options: six jumpers for device IOT selection, and one jumper for printer initialization (restore). The normal IOT device code is 50.

### 1.3.4 BC03R Signal Cable

The BC03R cable furnished with the LQP8 Printer System is a standard 7.62 m (25 ft) DIGITAL cable. A cable length of 15.24 m (50 ft) is available on special order.

### 1.3.5 BC80F-25 Interface Cable

The BC80F interface cable furnished with the LQP8/78 (i.e., LQP78) Printer System is a standard 7.62 m (25 ft) DIGITAL cable. It connects to the VT78 DECstation processor-display unit through the parallel I/O plug on the rear interconnection panel.

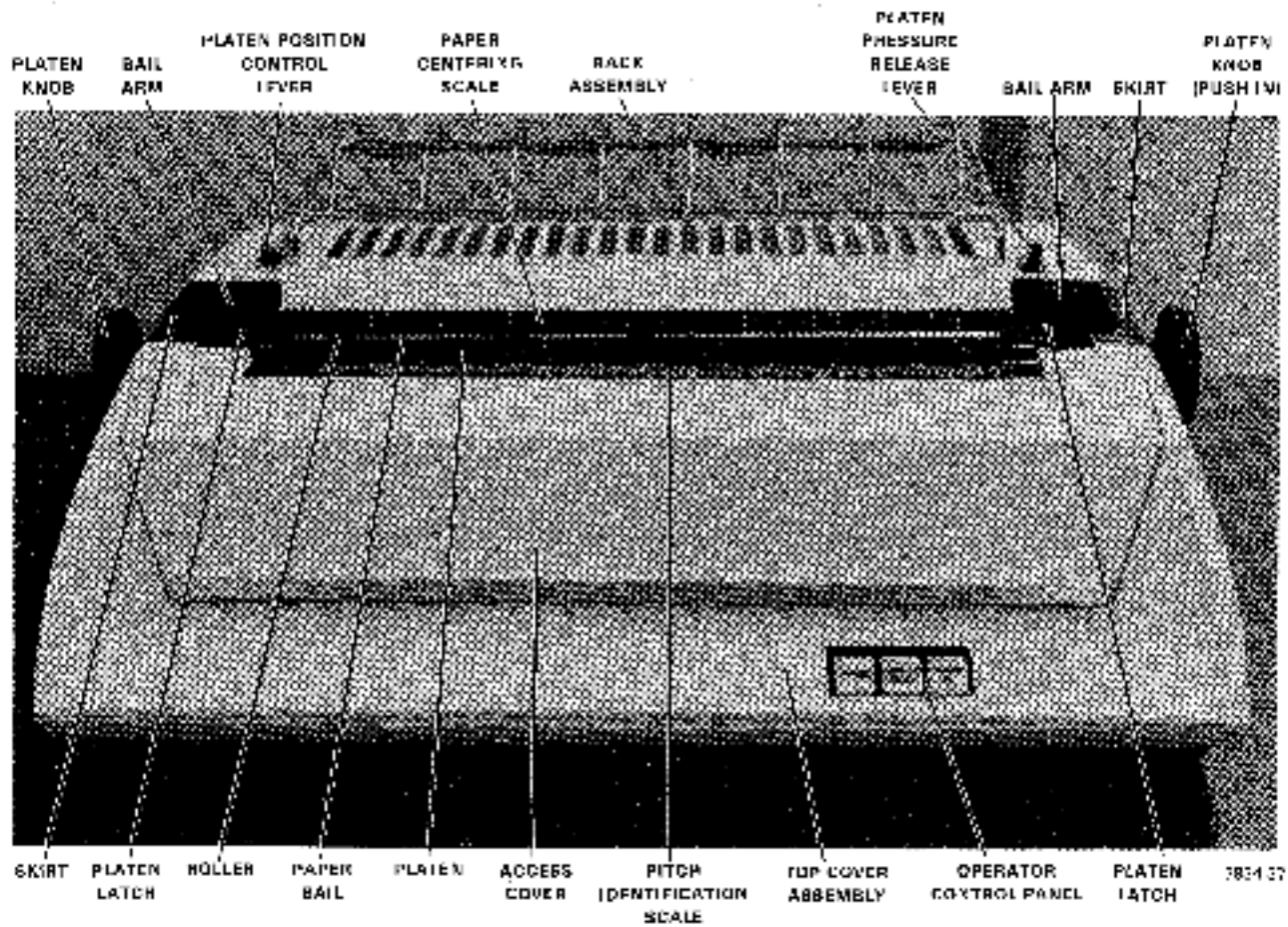

Figure 1-2 LQP01 Printer Without Forms Tractor

#### 1.4 APPLICABLE DOCUMENTS

This manual and the *Diablo Series 1300 HyType II Printer Manual* must be used together for a complete understanding of LQP8 Printer Systems. The prime subject of this manual is the LQP8-E controller. However, in addition to the LQP8-E controller, this manual also includes sections covering printer installation, operation, programming, and preventive maintenance. The prime objective of the Diablo printer manual is the printer itself. That manual presents a detailed discussion of the print mechanism and also covers detailed theory and maintenance.

Table 1-5 lists other DIGITAL documents that are applicable to LQP8 Printer Systems.

Detailed controller logic diagrams, wiring diagrams, and board layout are contained in the LQP8 Field Maintenance Print Set (MP00098).

#### 1.5 PERFORMANCE SPECIFICATIONS

Complete performance specifications for an LQP8 Printer System are listed in Table 1-6. Note that the LQP8 is a high-quality printer designed for light-medium duty application. Service agreements for this device are available to cover field maintenance on typical applications. Time and materials service is available for printer applications which exceed medium duty usage; that is, over 70 printing hours per month or 10 million characters per month.

Table 1-5 Applicable Documents

Title	Number	Description
Series 1300 HyType II Printer Maintenance Manual	Diablo 82403P	Provides a detailed description of the Diablo Series 1300 Printers. Also covers installation, operation, theory, and basic maintenance.
Model 1329 Power Supply Maintenance Manual	Diablo 820013A	Covers description, installation, operation, theory, and maintenance of Model 1329 Power Supply. Also contains detailed parts list.
PDP-8/A Miniprocessor Handbook	*FB-04595 750200/0-19 04-25	Introduction to the basic PDP-8/A system. Describes internal design and packaging; PDP-8/A operating and real-time systems; instructions for operating and programming the PDP-8/A; the PDP-8/A Omnibus; standard interface hardware; the PDP-8/A semiconductor memory, with read only memory (ROM) programming instructions; PDP-8/A core memory systems; and user information to plan and prepare for installation of the PDP-8/A.

**Table I-5 Applicable Documents (Cont)**

Title	Number	Description
PDP-8/A Miniprocessor User's Manual	*EK-8A002-MM-001	Contains detailed description of PDP-8/A miniprocessor. Also covers PDP-8/A installation, Omnibus interfacing, detailed theory of operation of CPU and memories, I/O options, and power supply. Concludes with detailed maintenance and troubleshooting information, and complete print set.
PDP-8/E, -8/M, and -8/F Small Computer Handbook	*018-00173-2546-S-09-100	Introduction to the basic PDP-8/E, -8/M, and -8/F systems, with emphasis on the PDP-8/E. Describes internal design and packaging, operating systems and software, programming, Omnibus interfacing, peripherals, installation planning, and I/O design.
PDP-8/E, -8/F, and -8/M Processor Maintenance Manual	*LK-8F001-MM-004	A three volume series containing detailed installation procedures, logic theory, and maintenance instructions. Volume 1 deals with the basic computer; Volume 2 covers internal bus options; and Volume 3 is concerned with external bus options.
OS/8 Handbook	*DEC-58-OSIIBA-A-D	Describes the OS/8 Operating System for the PDP-8/E computer.
DS310 Installation Manual	FK-DS310-IN-000	Contains detailed information on the installation and checkout of the DEC DATASYSTEM 310 Word Processing System.
Operator's Tutorial Manual	EK-1Y81M-TM-001	The Operator's Tutorial Manual is used together with a teaching diskette (floppy) to provide programmed self-instruction for the WPS-8 software system. This includes: recording, editing, printout, file manipulation, and other word processing functions.

**Table 1-5 Applicable Documents (Cont)**

Title	Number	Description
System Reference Guide	EK-TY88R-RC-001	A pocket-sized summary of all the features of WPS-8. Its purpose is to provide quick, concise reminders about system operation after completion of training.
System Reference Manual	FK-TY88R-RM-001	A technically oriented manual that provides more detailed explanations of features and functions than those presented in the Operator's Tutorial Manual.

\*Applicable manuals are furnished with the system at time of installation. The document number depends upon the specific PDP-8 family processor.

**Table 1-6 LQP8 Performance Specifications**

---

<b>Print Speed</b> Up to 45 characters per second
<b>Character Set</b> 96 characters
<b>Print Line</b> 33.27 cm (13.1 in) 132 columns on 10 pitch 158 columns on 12 pitch
<b>Paper Width</b> 38.1 cm (15 in) maximum
<b>Carriage Return</b> 300 ms maximum
<b>Tabulation</b> Horizontal tab in either right or left direction
<b>Column Spacing</b> 60 positions per inch 120 positions per inch selectable
<b>Paper Feed</b> Up or down (without forms tractor); up only (with forms tractor)

---

**Table 1-6 LQP8 Performance Specifications (Cont)**

---

<b>Line Spacing</b>	48 positions per inch nominal
<b>Paper Feed Speed</b>	10.16 cm (4 in) per second plus 50 ms settling delay (typical)
<b>Paper Skew</b>	Movement from one line to any position on next line
<b>Paper Feed Forms Thickness</b>	Manual selection, up to 0.0686 cm (0.027 in)
<b>AC Power Requirements</b>	115 Vac or 230 Vac $\pm$ 10%, 50 or 60 Hz $\pm$ 1 Hz
<b>DC Power Requirements*</b>	
+ 5 Vdc @ 4 A	regulated within 2%
+15 Vdc @ 6 A peak	regulated within 5%
-15 Vdc @ 6 A peak	regulated within 5%
100 W	(typical average)
<b>Ribbon Element</b>	Interchangeable cartridge with end-of-ribbon indicator for mylar ribbons
<b>Ribbon Type</b>	Single-color cloth or film-base carbon (mylar)
<b>Paper Feed Capability</b>	Friction Feed Adjustable Tractor Feed
<b>Physical Characteristics (Printer)</b>	Dimensions 59.06 cm (23.25 in) long $\times$ 34.37 cm (13.53 in) wide $\times$ 22.23 cm (8.75 in) high (without tractor) $\times$ 26.91 cm (10.75 in) high (with tractor)
	Weight (with tractor) 12.70 kg (28 lb) Weight (without tractor) 12.25 kg (27 lb)
<b>Physical Characteristics (Desk)</b>	Dimensions 91.44 cm (36 in) long $\times$ 60.96 cm (24 in) wide $\times$ 68.58 cm (27 in) high
<b>Physical Characteristics (Power Supply)</b>	Dimensions 45.72 cm (18 in) long $\times$ 20.73 cm (8.16 in) wide $\times$ 8.31 cm (3.27 in) high

---

**Table 1-6 LQP8 Performance Specifications (Cont)**

---

**\*\*Physical Characteristics (Printer, Desk, and Power Supply)**

Dimensions (overall) 91.44 cm (36 in) long  
× 60.96 cm (24 in) wide × 95.89 cm (37-3/4 in) high

**Recommended Operating Conditions**

Temperature 18° C to 24° C (65° F to 75° F)  
Humidity 40% to 60%

**NOTE**

**Keep the system out of direct sunlight. Maintain the recommended humidity range to prevent static electricity.**

**Suggested Application**

Not more than 70 printing hours per month or 10 million characters per month

---

\*Furnished by printer power supply.

\*\*Excludes BC03R signal cable. With forms tractor.



## CHAPTER 2 INSTALLATION AND CHECKOUT GUIDE

### 2.1 GENERAL

This chapter contains step-by-step instructions for unpacking the LQP8 Printer System and performing cabling and interconnections. The printer should be installed in an area that is free of excessive dust, dirt, corrosive fumes, and vapors. To ensure that the unit has proper ventilation and cooling, the ventilation openings at the top and bottom of the printer housing should not be obstructed. Adequate clearance must also be provided for servicing the unit (refer to Figure 2-1).

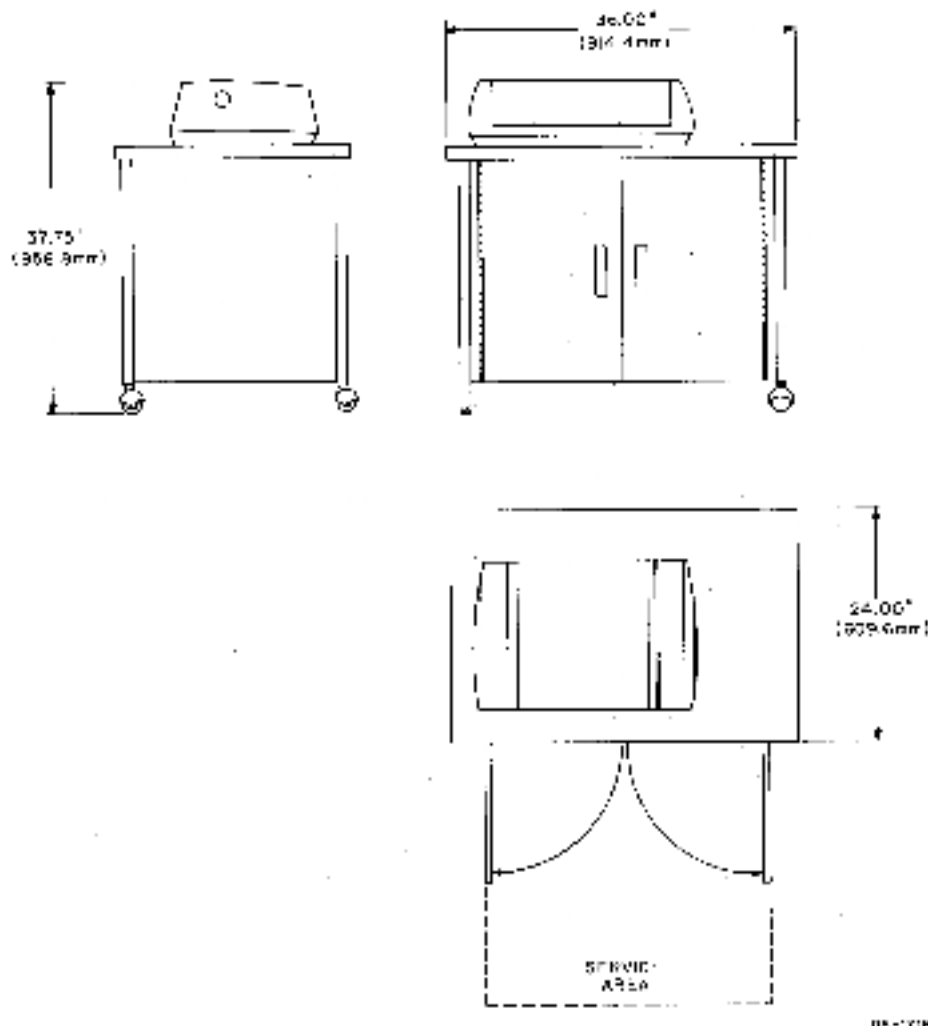

Figure 2-1 Site Considerations for LQP8 Printer and Desk

## 2.2 UNPACKING AND INSPECTION

The LQP8 Printer System is normally shipped in two separate containers: one contains the LQP01 printer, desk, and power supply and comes as an assembled unit; and one carton contains the LQP8-E controller and the BC03R signal cable. A shipping container inside the desk contains the forms tractor option. The platen, paper guide cradle, ribbon cartridge, and print wheel are all installed in the printer prior to shipment. No special instructions are needed and/or required for unpacking the controller or the BC03R signal cable. To unpack the LQP01 items, proceed as follows:

1. Cut the steel retaining straps securing the shipping carton and discard them (Figure 2-2).
2. Remove the top half of the slotted carton by sliding it upward and over the contents of the shipping carton.
3. Remove the poly bag.
4. Cut and remove the plastic strapping around the ends of the desk and remove the corner supports from the desk.
5. Remove the shipping retainer bar (held in place by screws) from the desk feet.
6. Remove all shock-absorbing packing material from around the desk.
7. Remove the printer/desk assembly from the shipping skid and position it in the desired location. Adjust the leveling feet on the desk, as necessary, to level the entire unit.
8. Remove the filament tape that secures the desk doors. Then remove the two tie wraps securing the print head and carriage assembly (Figure 2-2).
9. Remove and unpack the forms tractor.
10. Make a visual inspection of the printer, desk, power supply, and other parts for possible shipping damage. Check the enclosed packing list for lost or missing items. Report any damaged or missing items to your local DIGITAL Field Service or Sales Office and to the local carrier.
11. If necessary, wipe all outer surfaces with a clean, soft, lint-free cloth to remove dust and other foreign particles.

## 2.3 INSTALLING THE CONTROLLER MODULE

Before installing the controller module in the Omnibus, check the jumper wire connections on the module (Figure 2-3). Jumpers W1 through W6 determine the device selection code, which can range from 00<sub>h</sub> to 77<sub>h</sub> (except Interrupt 00<sub>h</sub> and Extended Memory 20<sub>h</sub> through 27<sub>h</sub>). In a standard configuration, 50<sub>h</sub> is the normal device selection code. This is represented by jumpers W1 and W3 being soldered in place. To change the selection code, it is only necessary to change these jumper connections to the desired configuration (from 00<sub>h</sub> to 77<sub>h</sub>).

When jumper W7 is installed, a printer restore operation occurs whenever a system INITIALIZE pulse is generated. This feature may be bypassed, if desired, by unsoldering and removing jumper W7. (Refer to Chapters 4 and 5 of this manual for additional details concerning the printer restore operation.)

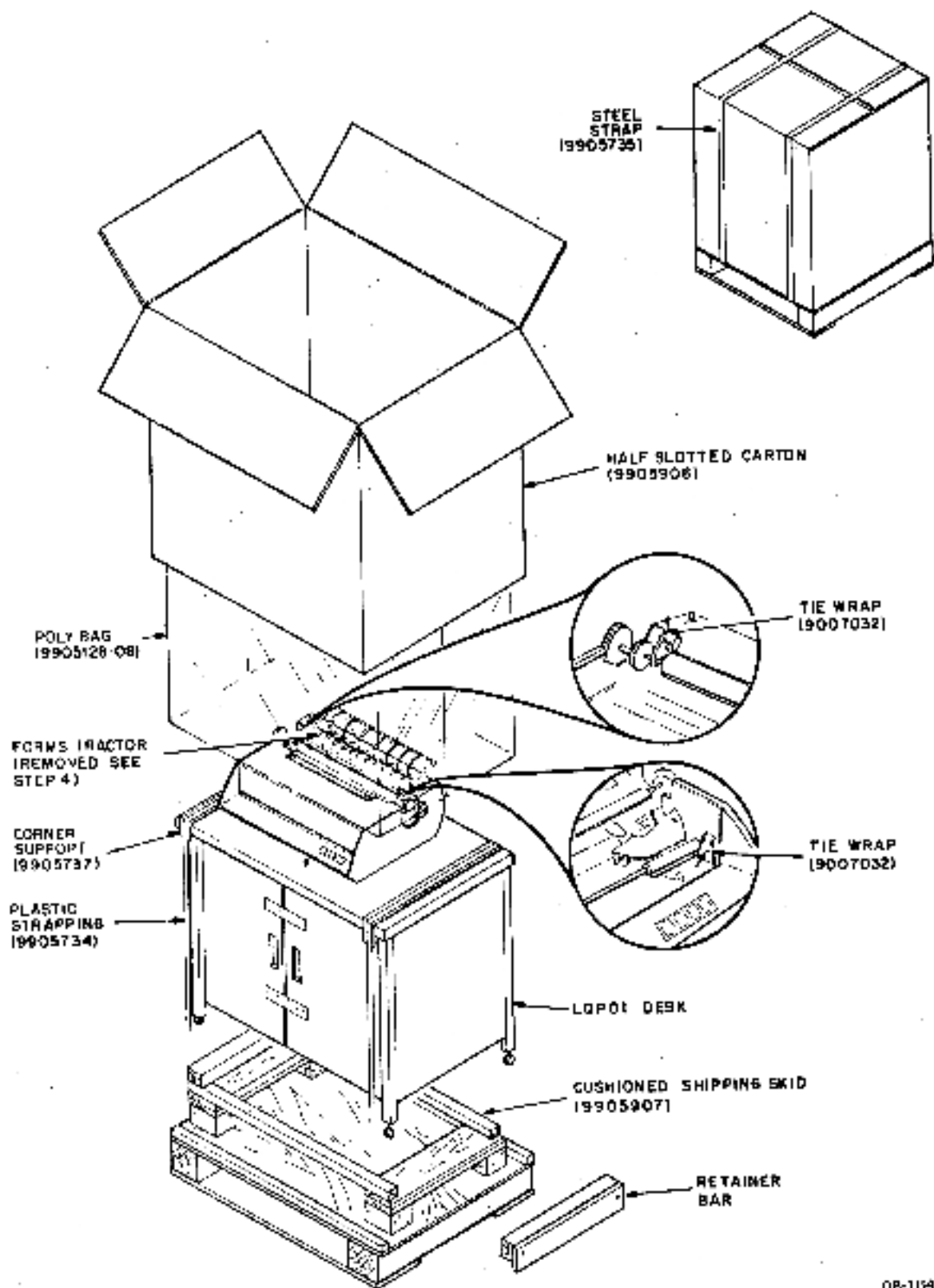

08-1145

Figure 2-2 Packaging of LQP8 Printer System

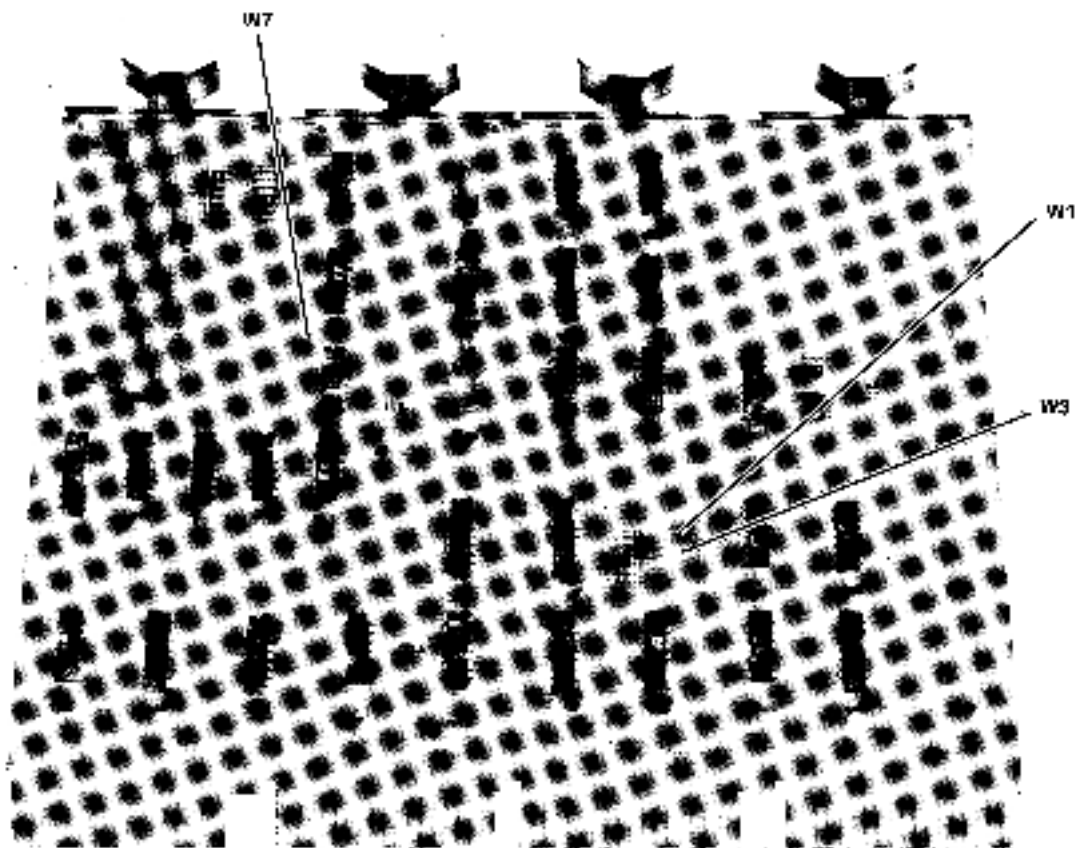

7834-90

Figure 2-3 Jumper Wires on LQP8-E Controller Module

#### 2.4 INSTALLING THE BC03R SIGNAL CABLE

To install the signal cable, proceed as follows:

1. Lift and remove the printer access cover, as shown in Figure 2-4.
2. Remove the platen (see Paragraph 3.10 for details).
3. Move the top cover release levers (Figure 2-5) fully forward (toward the control panel). This enables the entire printer top cover to be removed for access to the printed circuit boards (Figure 2-6).
4. Route the BC03R signal cable through the printer cabinet as shown in Figure 2-7. Refer to Appendix D for pin assignments for the power supply and connector cable.

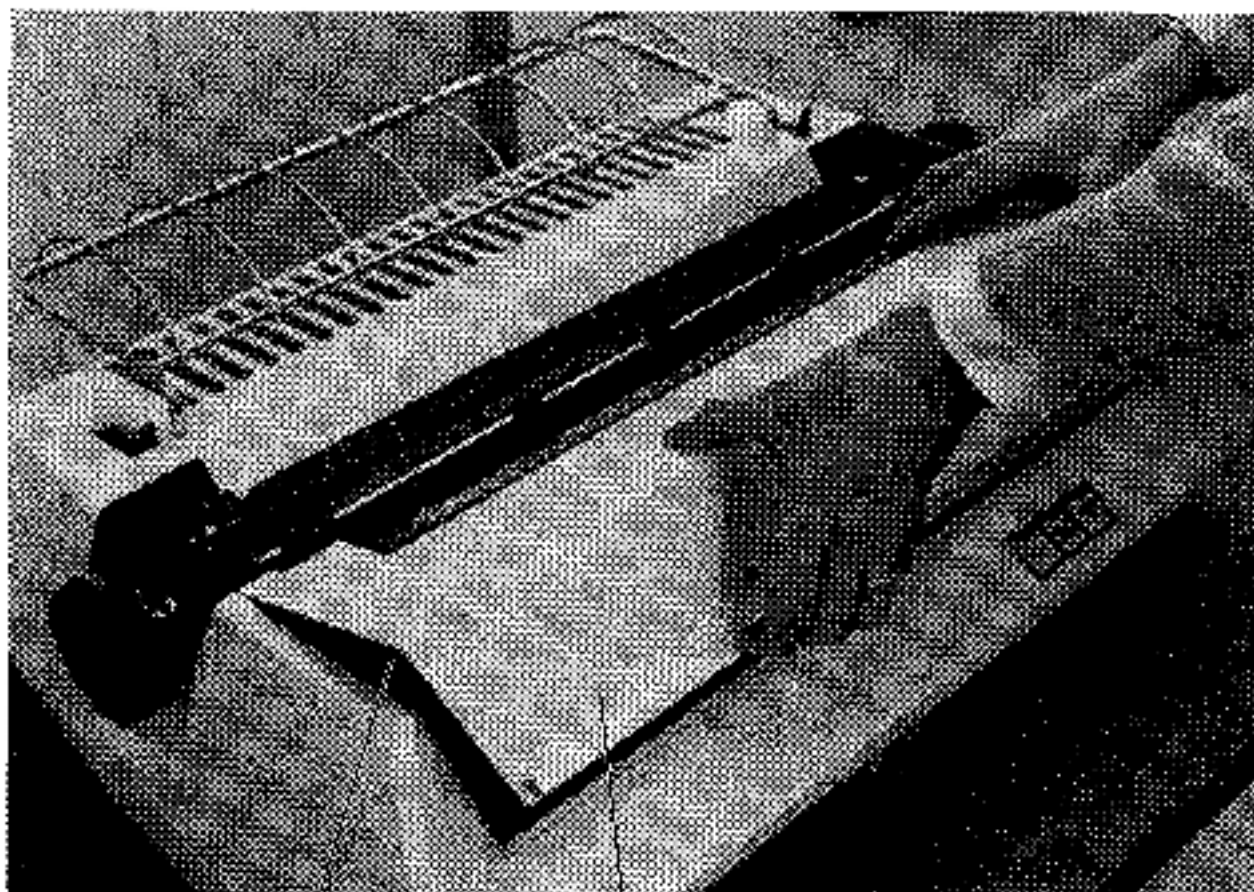

ACCESS  
COVER  
LATCH

ACCESS  
COVER

7874 32

Figure 2-4 Raising Printer Access Cover

5. Plug one end of the BC03R cable into the connector on printer module Logic 1 (Figure 2-6). Plug the other end of the cable into the connector on the LQP8-E controller module. (Subsequently, the controller module will be connected to the Omnibus in the user system.)

**NOTE**

After installing the signal cable, check that the power cable connection is also secure (Figure 2-6). Then, check that the printed circuit boards are seated properly. These boards are keyed for proper installation.

6. Make sure that the paper guide cradle (Figure 2-8) is installed.

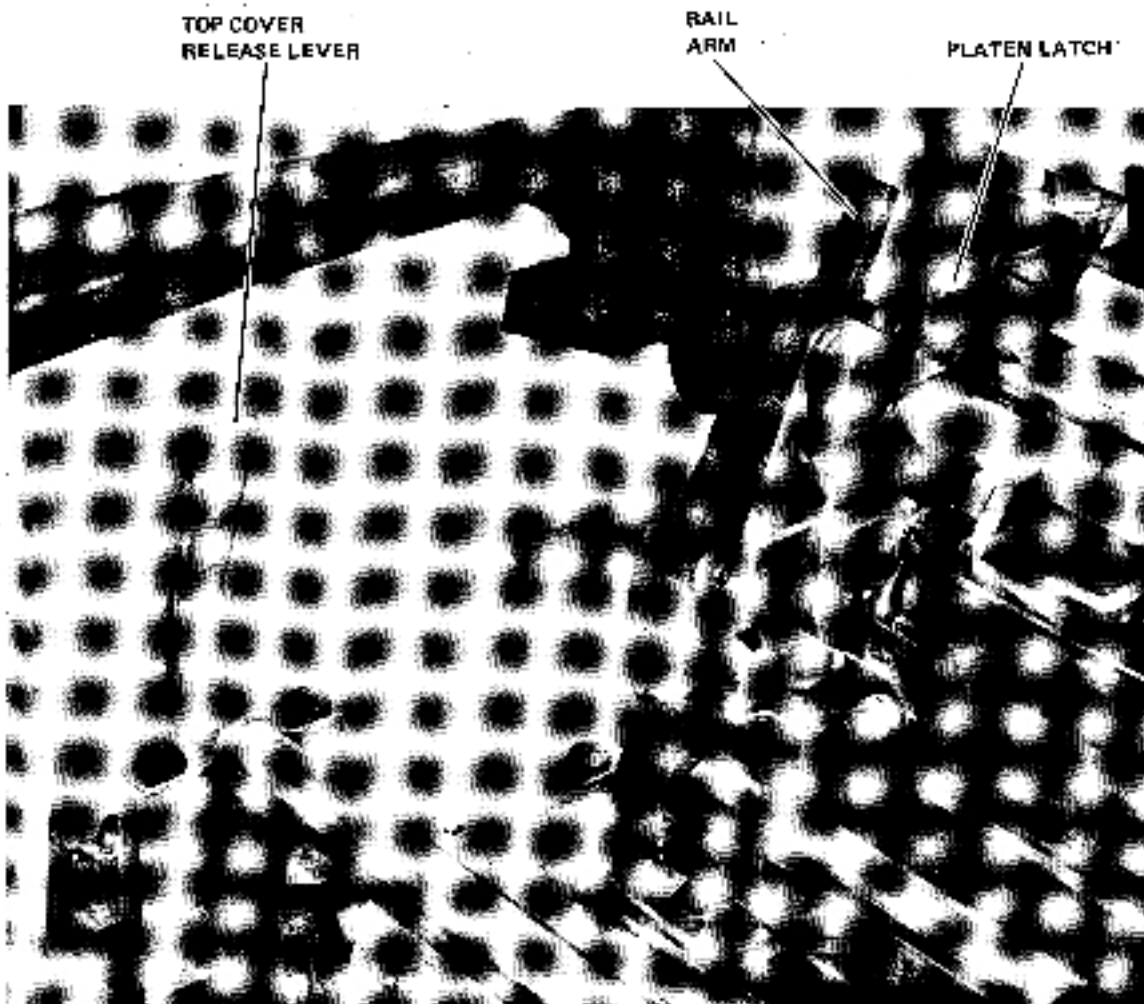

7834-10

Figure 2-5 View Showing Top Cover Release Lever

7. Reinstall the printer top cover. (It will be necessary to move the top cover release levers to seat the cover properly.)
8. Reinstall the platen and skirts (see Paragraph 3.12 for details).
9. Reinstall the printer access cover.

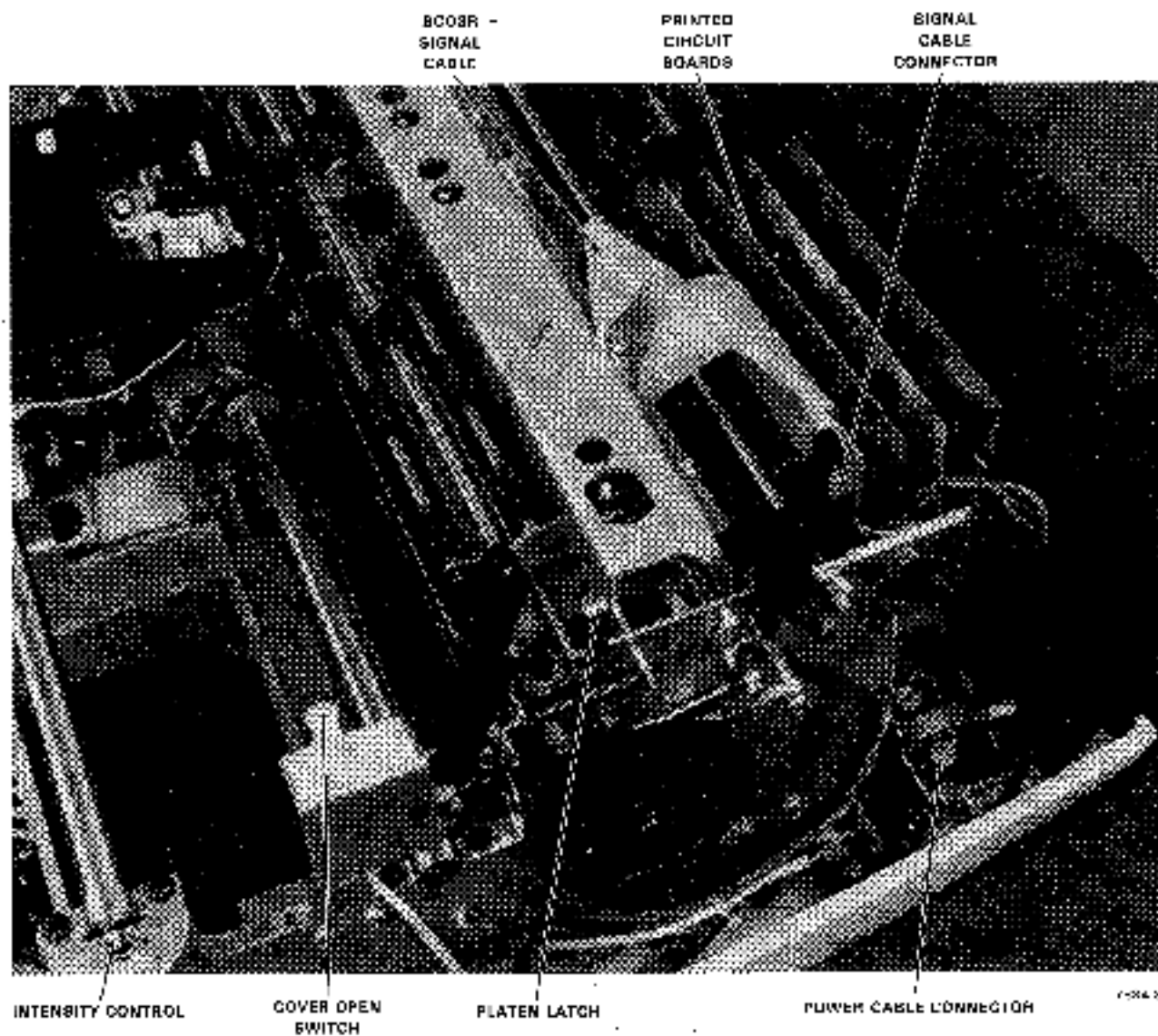

DO NOT FOLD CABLE

Figure 2-6 View Showing Power and Signal Cable Connections

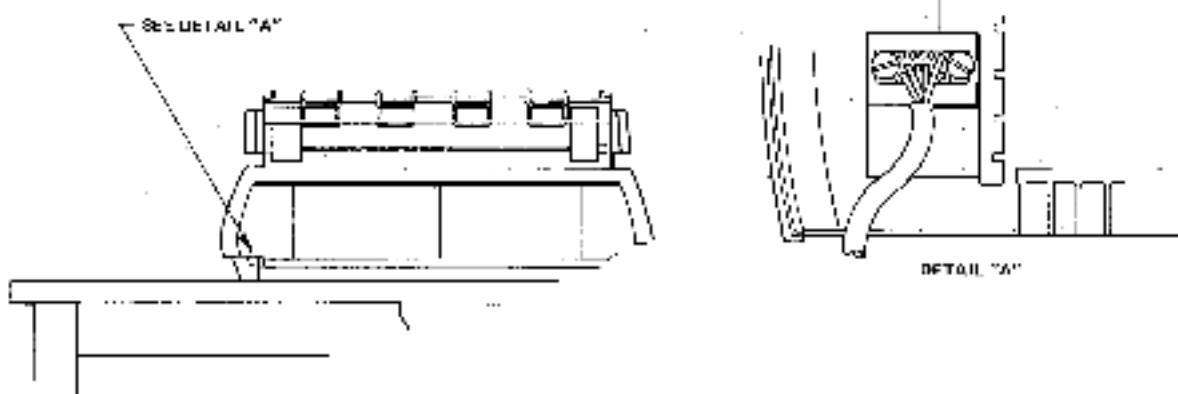
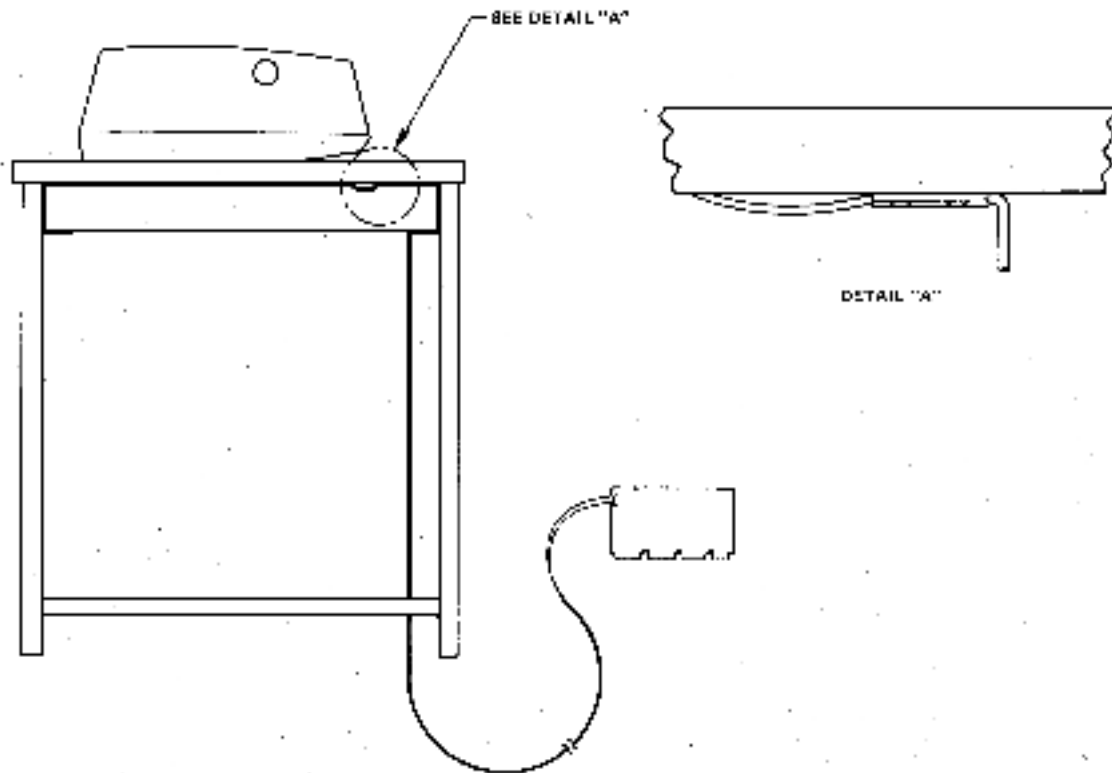

DN 1043

Figure 2-7 Interconnection Diagram for Typical LQP8 Printer System

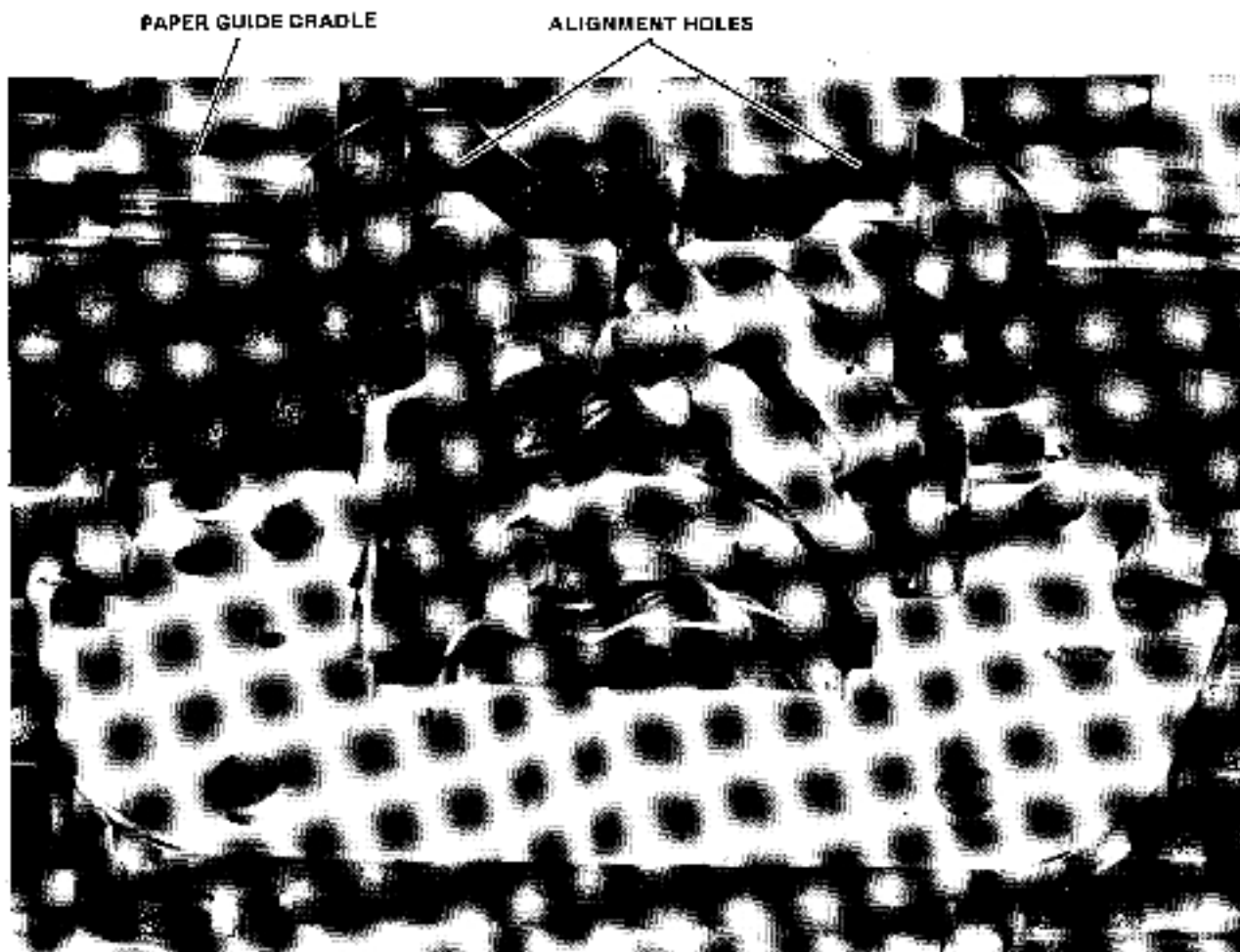

7634-4A

Figure 2-8 Paper Alignment Holes

### 2.5 PAPER INSTALLATION/ALIGNMENT (Without Forms Tractor)

Proceed as follows, using single-sheet lined paper (or substitute), to align the paper:

1. If necessary, move the platen pressure release lever (Figure 1-2) away from the platen (to increase pressure).
2. Pull the paper bail away from the platen.
3. Holding the paper aligned horizontally to provide the desired margins, insert it into the printer over the rack assembly, and behind the platen. Adjust the platen position control lever, as required (full forward for single-sheet paper).
4. Use the platen knob to roll the paper into the printer until it is approximately 5.08 cm (2 in) above the paper bail.

5. If necessary, pull the platen pressure release lever forward and manually position the paper until it is straight. Two paper alignment holes (Figure 2-8) are provided for this purpose. (A straight line on the paper should just touch the bottom edge of each alignment hole. This is where the bottom of each printed character will touch.) When alignment is complete, move the platen pressure release lever back, away from the platen.
6. Push the paper bail back. The rollers should ride on the paper.
7. Position the paper for the first line of printing. Push the right-hand platen knob in and rotate (adjust) it if fine positioning is necessary.

## **2.6 PRINT DENSITY ADJUSTMENT**

The hammer intensity control switch, shown in Figure 2-6, has three positions: high (H), medium (M), and low (L). The desired setting will depend primarily on font size and the number of copies being printed. As a rule, the switch is initially placed in the medium (center) position and moved, if necessary, after the test printout is made (Paragraph 2.7).

## **2.7 PRE-OPERATIONAL CHECKOUT**

The purpose of the pre-operational checkout is to ensure that the printer has been installed and loaded properly and is ready for operation. Instructions for running the test program are contained in the MAINDEC diagnostic listing (refer to Chapter 6). If the test must be stopped for any reason, such as adjusting print intensity or adding paper, simply press the PAUSE switch on the printer control panel. The PAUSE switch will light and cause the printer to finish all commands in process and then stop. When service is completed, press the PAUSE pushbutton to resume testing.

### **NOTE**

**If the PAUSE mode lasts longer than 5 seconds, the diagnostic will indicate a status error and will have to be reinitiated.**

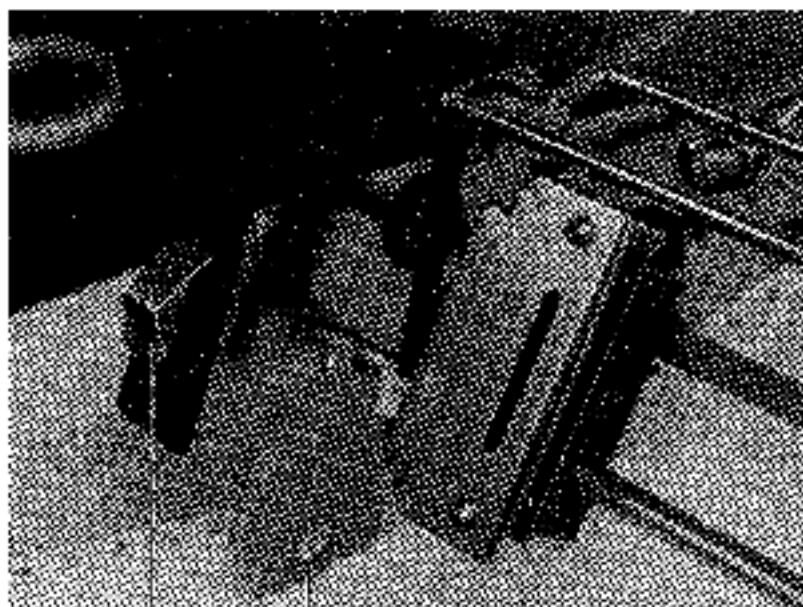

CLAMP  
BUTTON

CLAMP

703-10

A. Clamp in Normally Closed Position

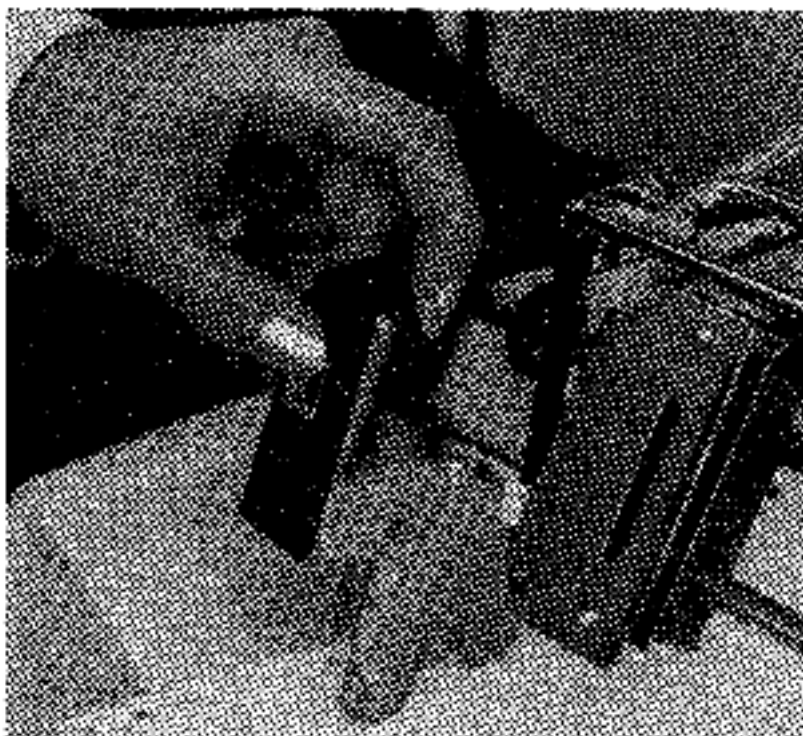

703-11

B. Opening Clamp by Pressing Clamp Button

Figure 3-1 Forms Tractor Clamp Assembly

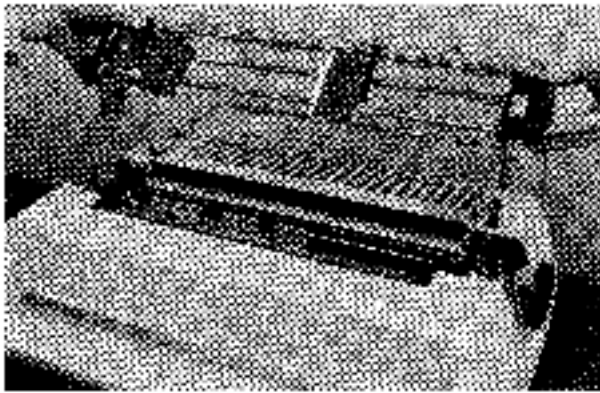

A. Raise Forms Tractor Over Printer

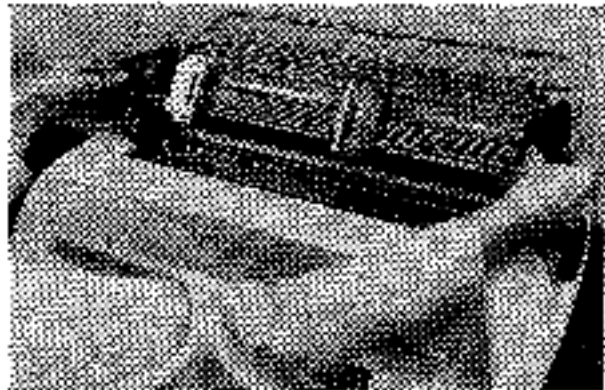

B. Lower Forms Tractor and Depress Clamp Buttons to Engage Clamps to Shaft Below

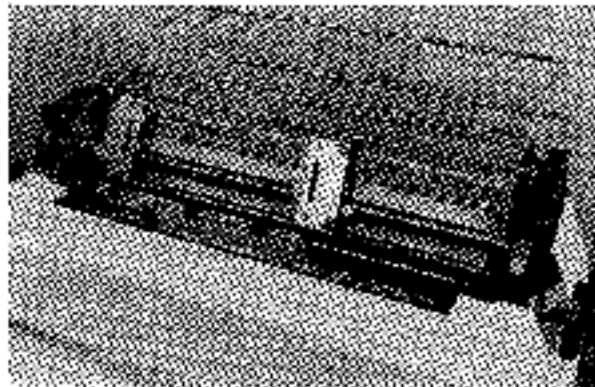

C. Forms Tractor Properly Seated

Figure 3-2 Forms Tractor Installation

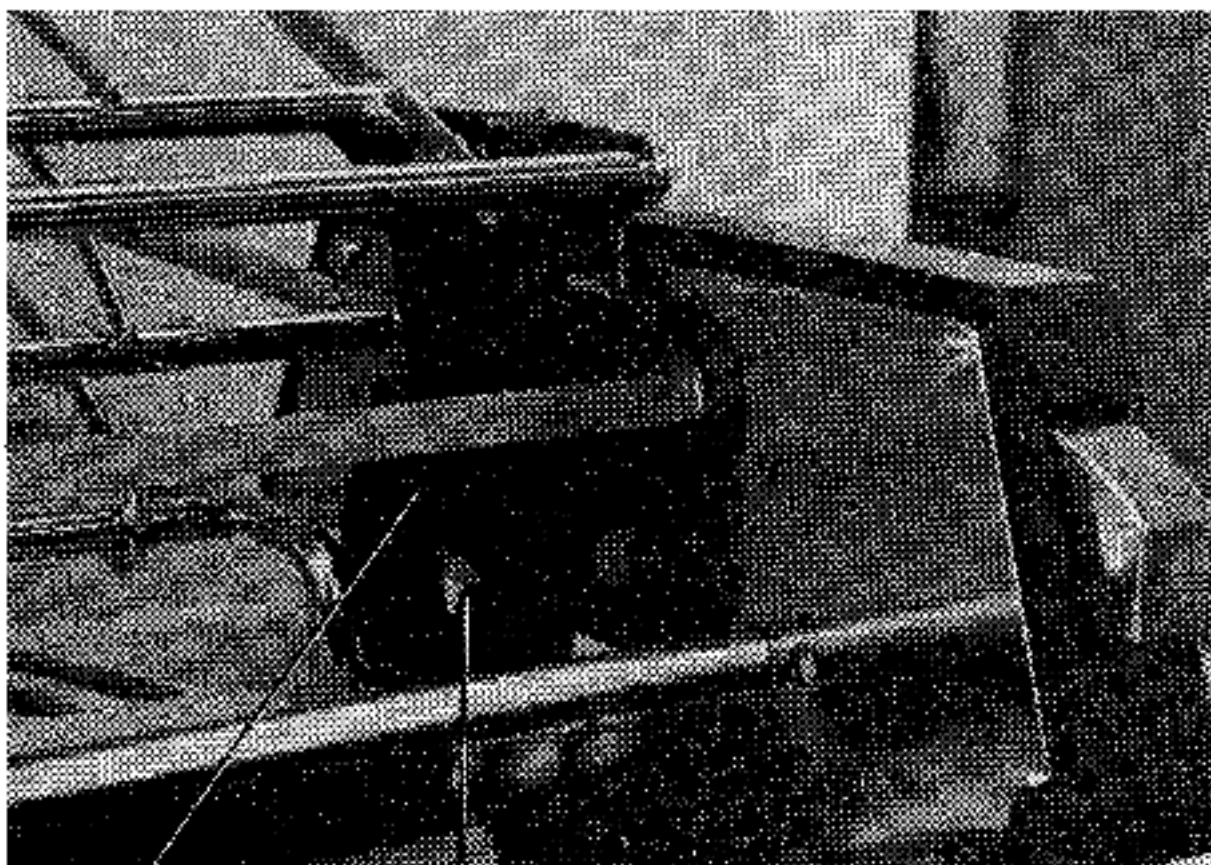

TAG

PLATEN PRESSURE RELEASE LEVER  
(IN FORWARD POSITION)

7874 20

Figure 3-3 Positioning of Platen Pressure Release Lever  
When Forms Tractor Is Installed

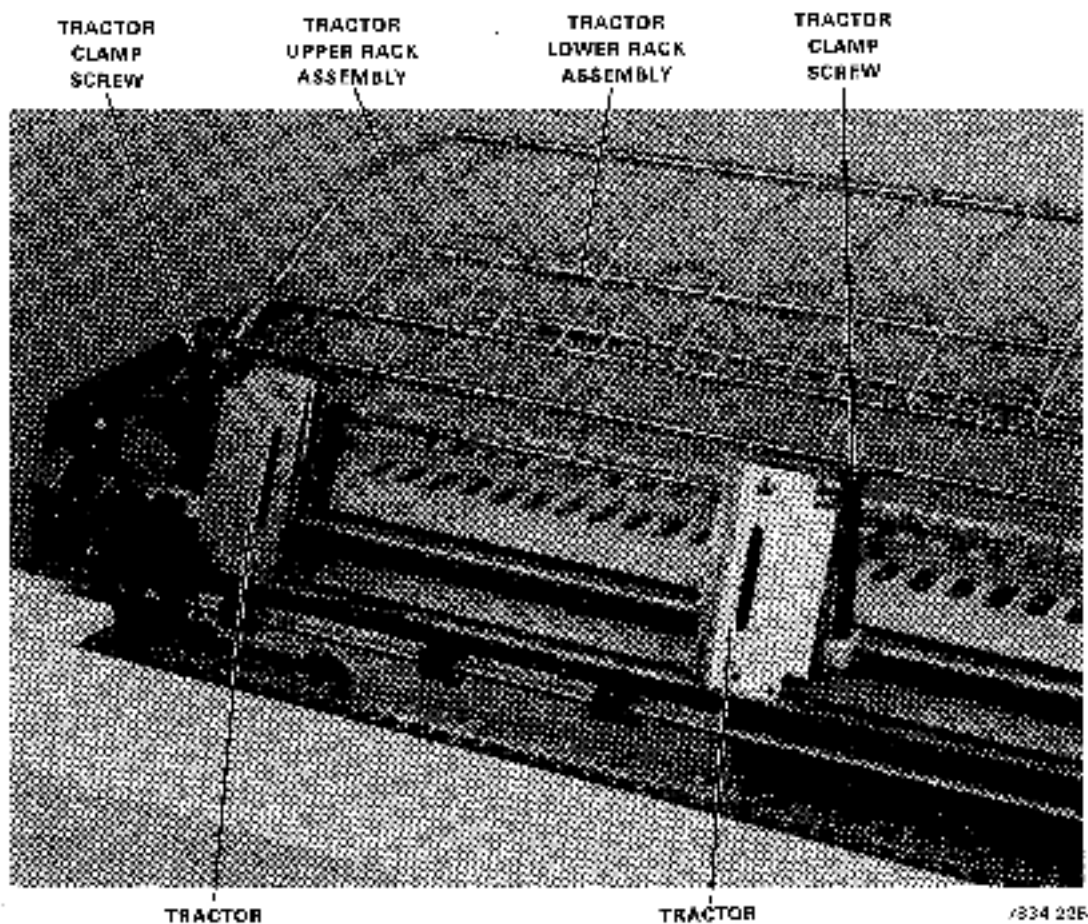

Figure 3-4 Major Elements of Forms Tractor

Figure 3-5 illustrates the procedure for loading fanfold paper through the slot in the desktop, Figure 3-6 illustrates the procedure for loading fanfold paper from the rear of the desk. The basic loading procedure is essentially as follows:

1. Make sure the platen pressure release lever is forward, as shown in Figure 3-3.
2. Pull the paper bail forward, away from the platen.
3. Insert the first of the continuous forms into the printer. If loading from the rear, move paper over the tractor lower rack assembly and down behind the platen. Roll the paper around the platen until it is approximately 15.24 to 20.32 cm (6 to 8 in) above the typing line. If loading from the front, move the paper directly through the slot in the desk top, in front of the platen.
4. Open the left-hand tractor assembly. Place the paper form over the teeth and then close the tractor.



7014-39

Figure 3-5 Loading Paper Through Slot in Desk Top

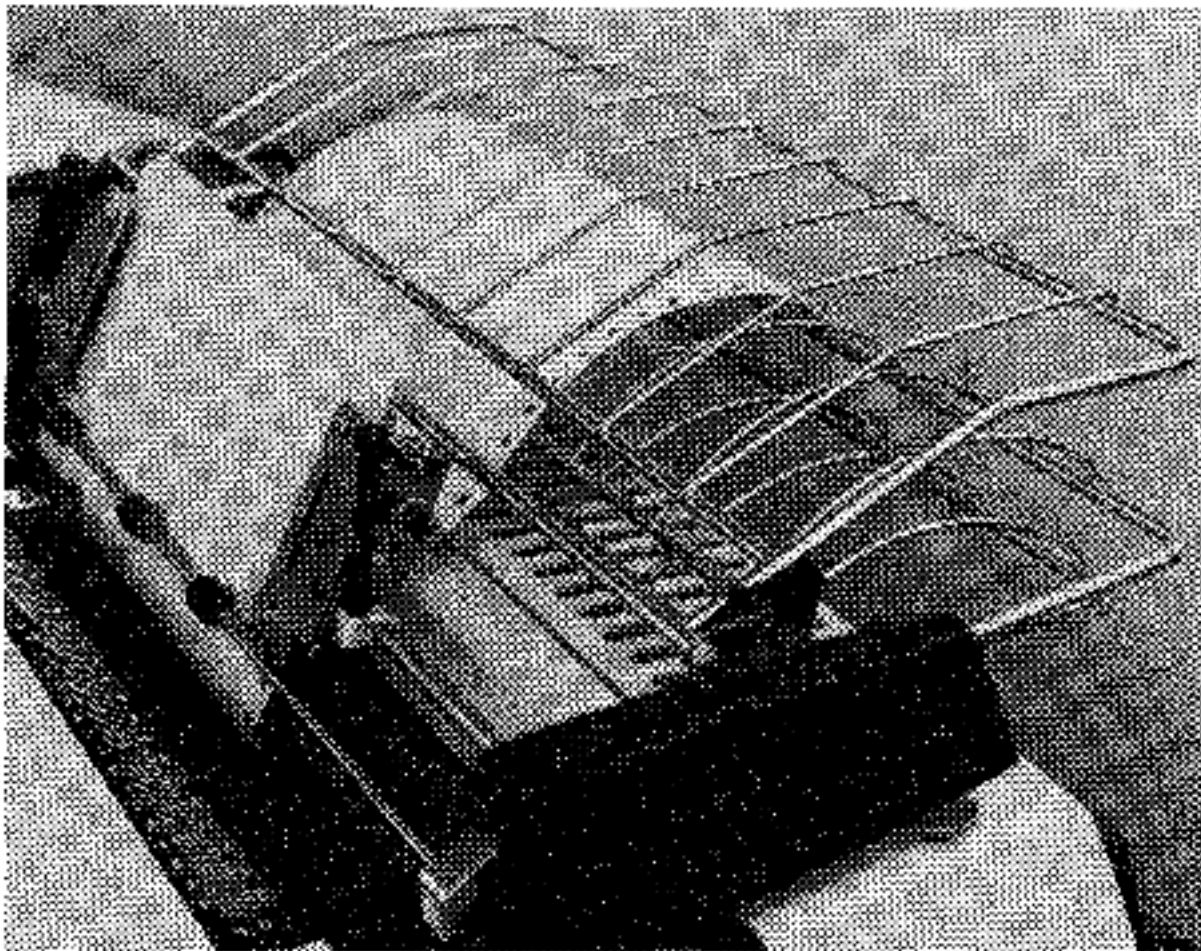

7024-14

Figure 3-6 Loading Paper in Forms Tractor from Rear

5. Align the form, place it over the teeth on the right-hand tractor assembly, and close that tractor. Some minor adjustment of the tractors may be necessary to ensure that the paper is not too tight or too loose.
6. Tighten the tractor clamp screws.
7. Push the paper bail back into position against the paper form.
8. Use the platen knob to position the form for the first line of typing. (Normally, the first form is used only to get the forms started through the forms tractor and is not used for printing.)

#### NOTE

The paper form should be aligned with the paper alignment holes (Figure 2-8). If necessary, adjust the feet on the forms tractor until alignment is correct.

#### CAUTION

Tear paper only along perforations. Support paper when tearing to avoid distorting the tractor-feed holes in the paper in the machine.

### 3.4 CHANGING RIBBONS

Remove the old ribbon cartridge as follows:

1. Remove the printer access cover (Figure 2-4).
2. Using both forefingers, push down on the two plastic latches (Figure 3-7A) that secure the ribbon cartridge to the platform.
3. Using both thumbs, tilt the front of the ribbon cartridge upward so that the ribbon is clear of the print wheel (Figure 3-7B).
4. Remove the ribbon cartridge and discard.

Install the new ribbon cartridge as follows:

1. Turn the small ribbon advance knob (Figure 3-7B) in the direction indicated by the arrow, enough to remove all slack from the ribbon.
2. Slide the exposed portion of the ribbon behind the two ribbon guide posts located in front of the print wheel (Figure 3-7A). Then snap the cartridge into place on the platform.
3. Gently rock the ribbon cartridge up and down several times to make sure that the ribbon is free of the print wheel.
4. If necessary, tighten the ribbon by means of the ribbon advance knob.

When completed, install the printer access cover.

### 3.5 CHANGING PRINT WHEELS

To remove the existing print wheel, proceed as follows:

1. First, remove the printer access cover and the ribbon cartridge (Figures 2-4 and 3-7).
2. Tilt the inner carriage assembly away from the platen and hold stationary with one hand (Figure 3-8).
3. With the other hand, remove the print wheel by pulling straight up on the knob at the print wheel hub (Figure 3-9). Place the print wheel in its protective case.

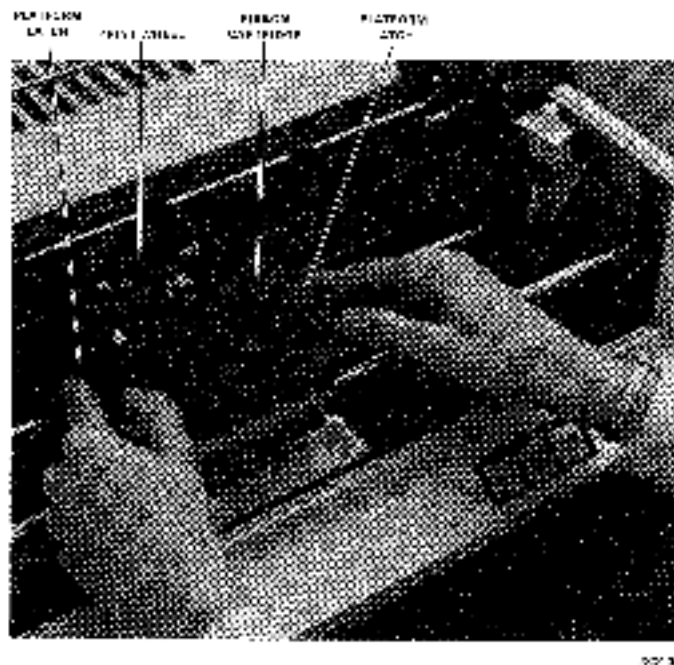

A. Press Down on Platform Latches

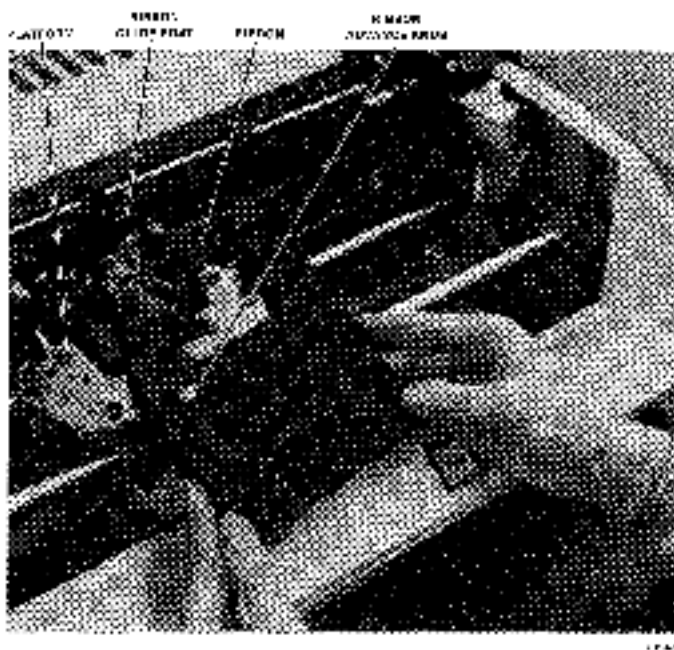

B. Tilt Ribbon Cartridge Upward  
Figure 3-7 Ribbon Removal



Figure 3-8 Inner Carriage Assembly Titled Away from Platen

To install another print wheel, proceed as follows:

1. Tilt the inner carriage assembly away from the platen to expose the print wheel motor shaft (Figure 3-8).
2. Remove the print wheel from its protective plastic case and position the wheel over the print wheel motor shaft (Figure 3-9), rotating the wheel until its alignment hole lines up with the alignment tab protruding from the shaft hub.
3. Press the hub of the wheel firmly onto the end of the print wheel motor shaft and lock the wheel in place.

**NOTE**

**Be sure the wheel is firmly seated or printing errors will occur.**

4. Move the inner carriage assembly back to its normal operating position.

When installation is completed, install the ribbon cartridge and then the printer access cover.

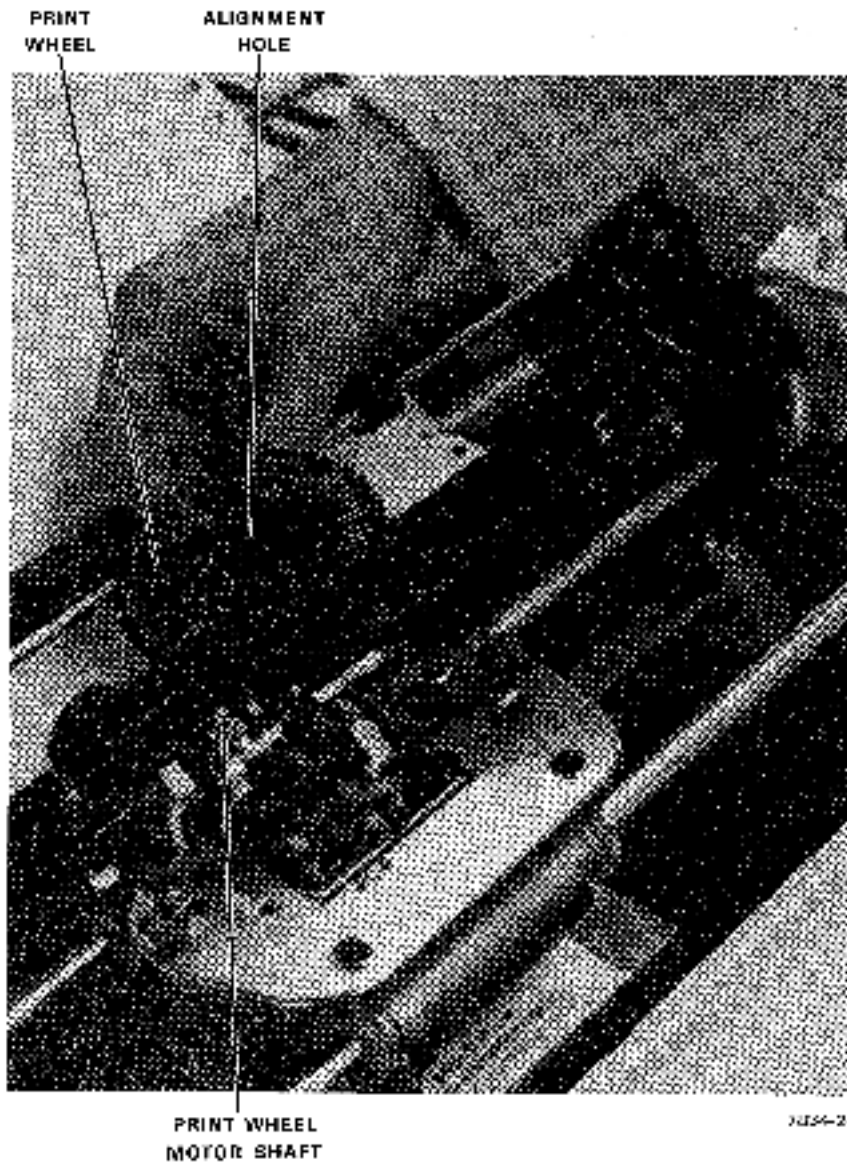

Figure 3-9 View Showing Print Wheel Motor Shaft  
and Print Wheel Alignment Hole

### 3.6 ENERGIZING THE PRINTER ASSEMBLY

The circuit breaker on the desk power control box controls power to the printer (Appendix D). When the circuit breaker is closed, its associated lamp will light, and ac power will be applied to the printer power supply. DC power will then be applied to the printer itself. When the printer is ready for operation, the PRINTER READY indicator on the operator control panel (Figure 1-2) should light. The printer is now ready to receive and print data received from the user system.

#### WARNING

The printer is electronically controlled. It has few moving parts and, therefore, provides trouble-free operation for long periods of time. The operator can help extend these trouble-free periods by exercising reasonable care in the handling of food and beverages around the printer. Should an accidental spill occur, maintenance personnel should be called as soon as possible to clean and check the unit thoroughly. For operator safety, dangling jewelry should not be worn since it could get caught in the printer carriage. Also, never make or break cable connections to the printer while power is on. Finally, remember that applying power to the printer initiates a Restore sequence, which includes movement of the carriage. Make sure the carriage is free to move before applying power.

### 3.7 NORMAL OPERATING PROCEDURE

Normally, the operator performs no maintenance on the printer except to load paper, change print wheels, and install ribbons. When the printer is energized, and operating on-line proceed as follows to stop the machine for servicing exhaustible supplies:

1. Press the PAUSE pushbutton. The PAUSE pushbutton should light. A short time later, the printing operation should stop.
2. Remove the printer access cover and perform the desired operation.
3. Install the printer access cover.
4. Press the PAUSE pushbutton. The PAUSE pushbutton indicator should go out. A short time later, the printer operation should continue.

If a mylar ribbon cartridge is installed, a sensor at the end of the ribbon will activate an electrical signal to stop the printer. When the printer stops, the PRINTER READY indicator will extinguish and the END OF RIBBON indicator will light. Proceed as follows:

1. Press the PAUSE pushbutton.
2. Replace the ribbon cartridge.
3. Press the PAUSE pushbutton.

When the printing operation continues, the PRINTER READY lamp will again light and the END OF RIBBON indicator will go out.

To prevent the printer from running out of paper during normal operation, add a sufficient supply before starting the operation. Allow approximately 2.54 cm (1 in) of fanfold paper for 2.5 hours of printing.

### 3.8 OPERATOR MAINTENANCE

Table 3-2 summarizes maintenance procedures that should be performed by the operator at scheduled intervals. These procedures are primarily limited to visual inspection and minor cleaning duties. Lubrication and major maintenance should be performed by qualified technical personnel only.

Table 3-2 Operator Maintenance Chart

Interval	Action to be Performed
Weekly or as required	Use isopropyl alcohol saturated cleaning pads and wipers* to remove fingerprints and other smudges from the printer frame and cover.
Monthly or as required	<p>With power removed, clean the inside of the carriage area. If necessary, remove and clean the forms tractor, paper guide cradle, and/or platen at that time. (See Paragraphs 3.9, 3.10, and 3.11 for instructions on removing the forms tractor, the platen, and the paper guide cradle, respectively.)</p> <p>Clean the platen pressure rollers and paper bail tires using a platen cleaner such as Fedron Platen Cleaner. Do not use alcohol on these or other rubber parts.</p> <p>The print wheel does not require cleaning under normal operating conditions. Slight ink build-up is normal, especially with a new cloth ribbon. Only unusually severe and prolonged operating conditions will make print wheel cleaning necessary, in which case isopropyl alcohol can be used.</p>

\*91% isopropyl alcohol.

### 3.9 FORMS TRACTOR REMOVAL

To remove the forms tractor, proceed as follows (Figure 3-2):

1. Make sure the paper bail is pulled forward.
2. Press the two clamp buttons down as far as possible and lift the forms tractor straight up. Exert sufficient strength to lift the assembly clear of the printer in one upward motion.

Instructions for re-installing the forms tractor are contained in Paragraph 3.3.2.

### 3.10 SKIRT AND PLATEN REMOVAL

In order to remove the friction-feed platen, it is first necessary to remove each skirt (Figure 3-10) as follows:

1. Remove the access cover.
2. Swing the back end of the skirt inward, toward the carriage assembly.
3. Push the front end of the skirt into the skirt holding bracket.
4. Lift up the back end of the skirt and remove the skirt completely from printer frame.

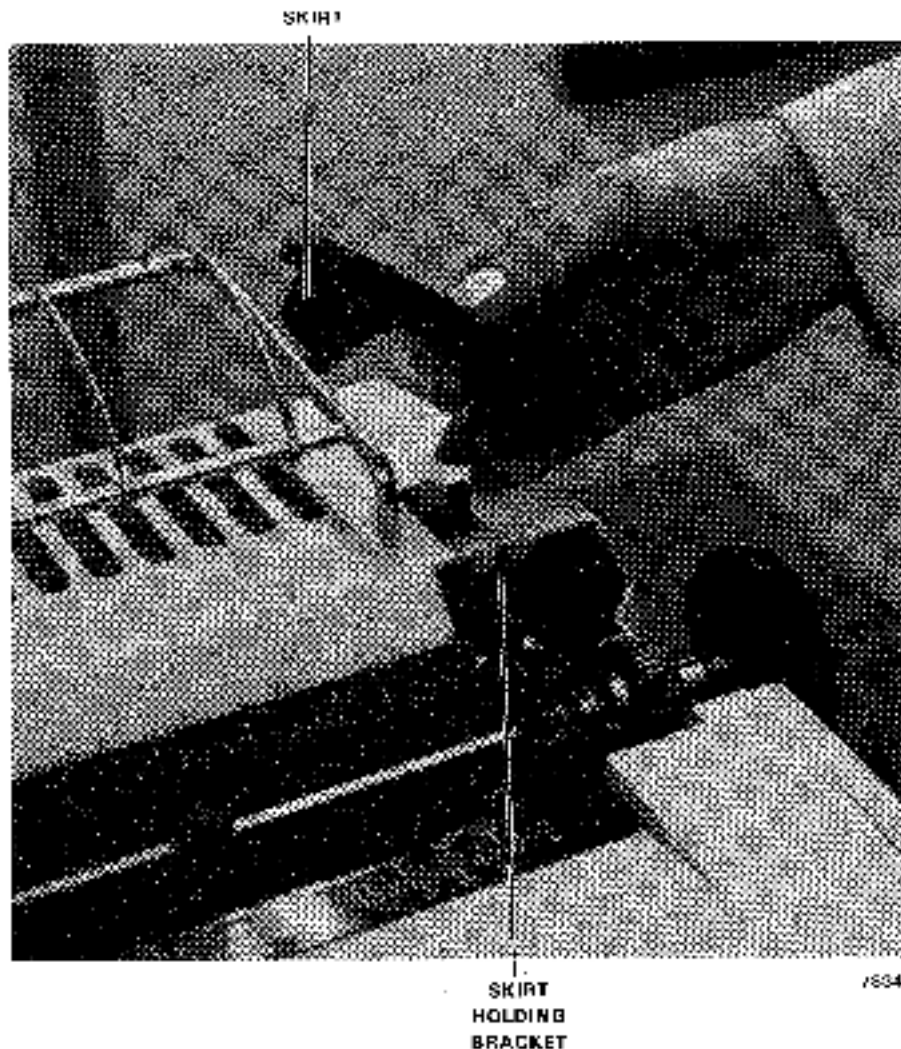

Figure 3-10 Skirt Removal

With the skirts removed, proceed as follows to remove the platen:

1. Move the paper bail forward.
2. Press both platen latches as shown in Figure 3-11.
3. Raise the platen upward, straight out of the printer.

### 3.11 PAPER GUIDE CRADLE REMOVAL/INSTALLATION

With the skirts and platen removed (Paragraph 3.10), the paper guide cradle can be lifted directly out of the carriage area (Figure 3-12). To re-install the cradle, place it over the rollers so that the rollers protrude through the slots in the cradle.

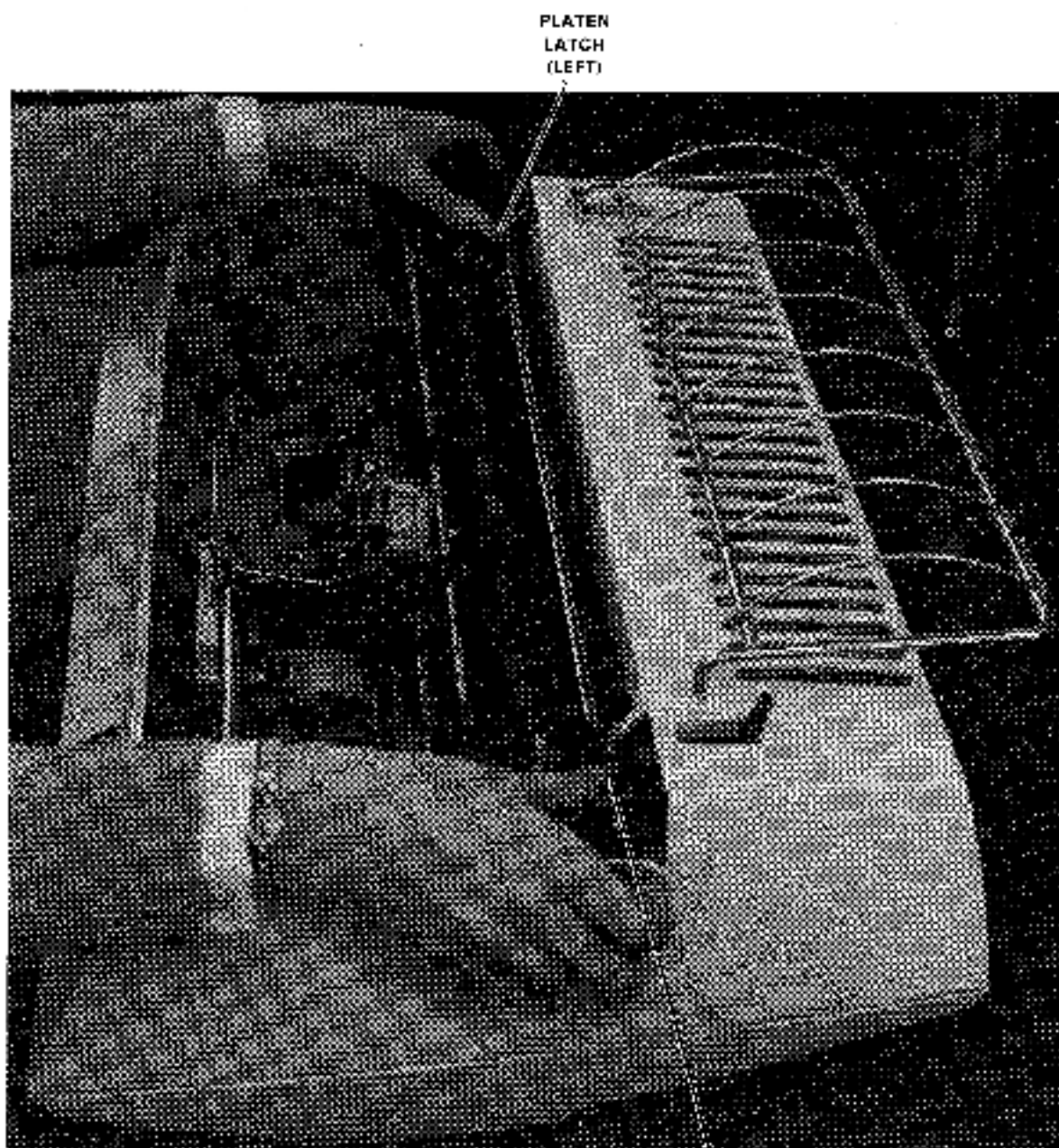

Figure 3-11 Pressing Platen Latches

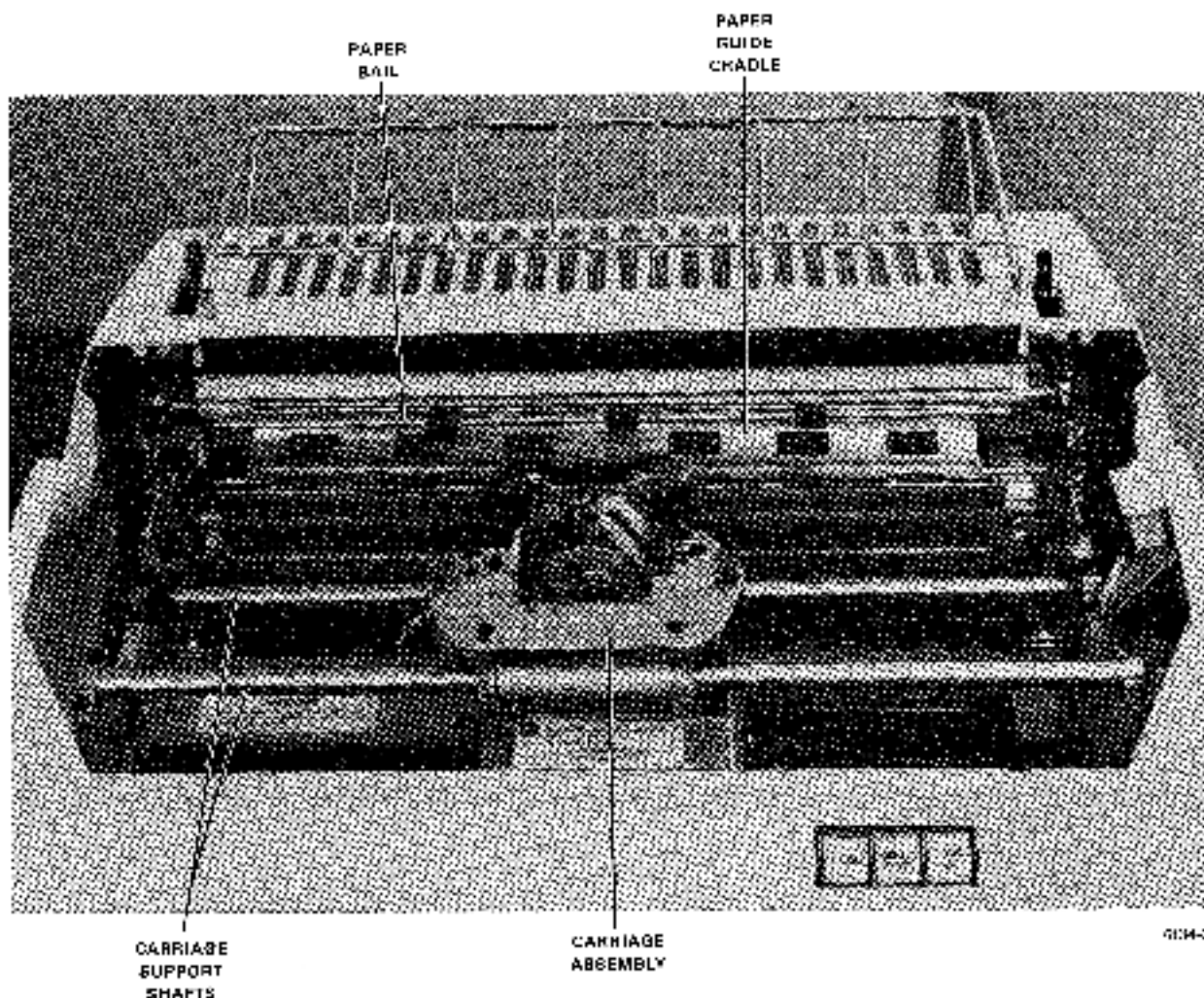
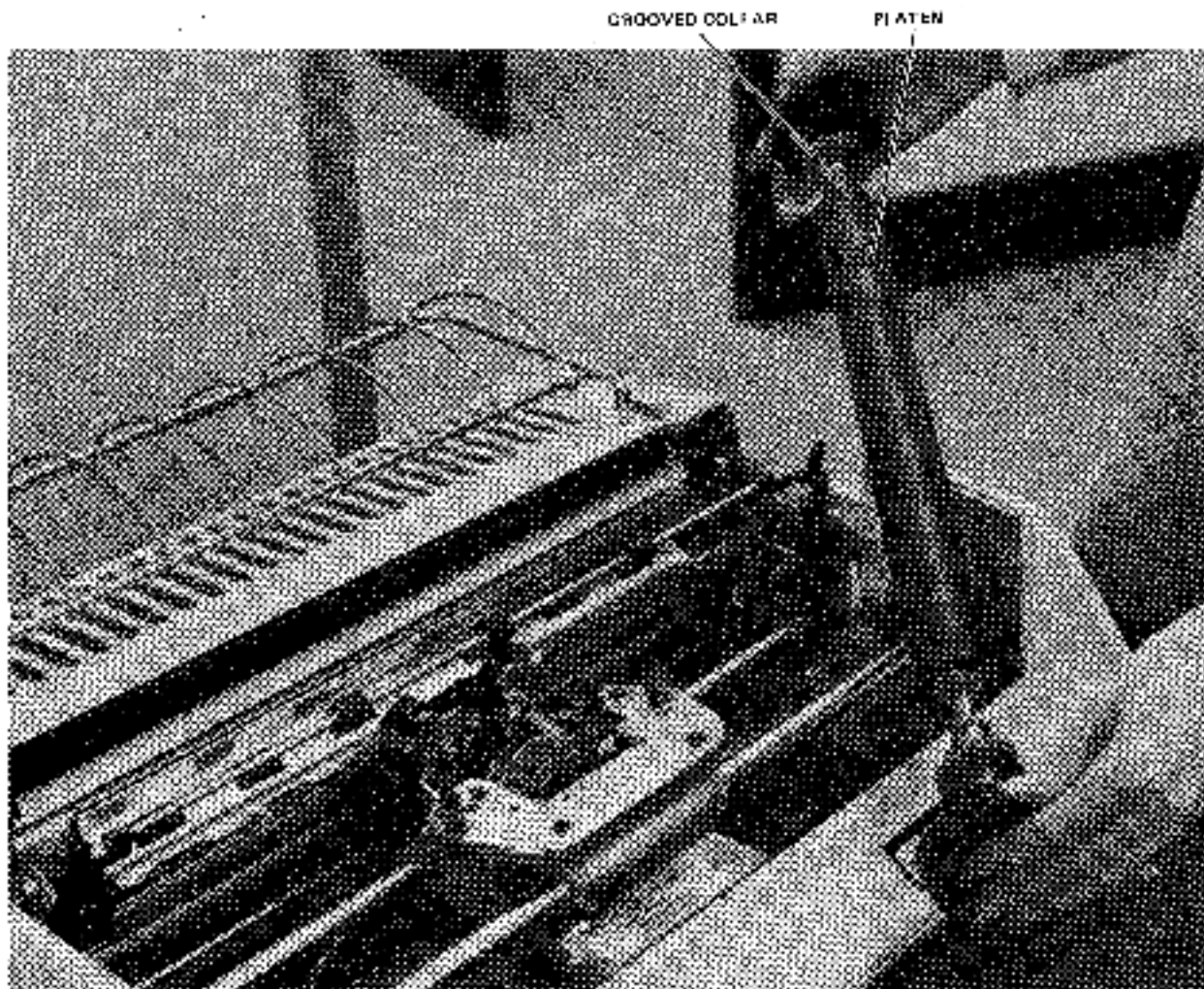

Figure 3-12 View Showing Paper Guide Cradle

### 3.12 PLATEN AND SKIRT INSTALLATION

With the skirts removed (Figure 3-10), proceed as follows to install the friction-feed platen:

1. Make sure the paper bail is pulled forward and the paper centering scale is moved up and out of the way.
2. Pick up the platen by both knobs, holding the end with the grooved collar in the right hand (Figure 3-13).
3. Position the platen over the printer so that the collar on the right end is aligned with the right-hand printer side frame. Press the platen latches with both thumbs (Figure 3-11) and install the platen so that the gears mesh. Release the platen latches.
4. Rotate the platen to be certain it is seated properly (Figure 3-14).



7034-0

Figure 3-13 Readying Platen for Installation

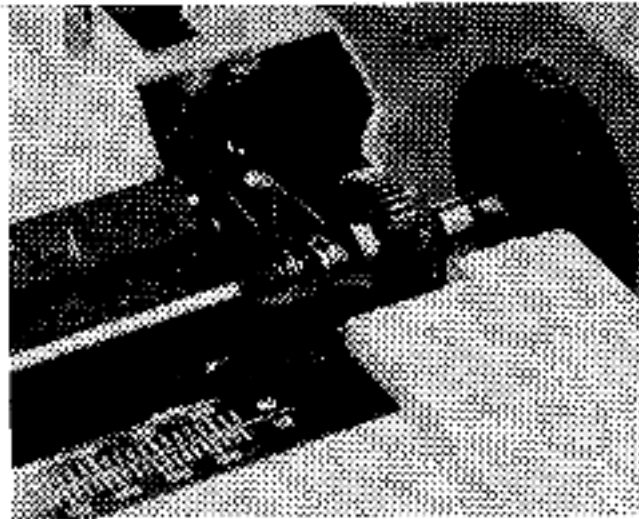

Figure 3-14 Platen Installed

To install a skirt, proceed as follows:

1. Make sure the access cover is removed.
2. Hold the skirt directly over the end of the cover frame near the platen knob (Figure 3-10).
3. Tilt the front end of the skirt slightly downward and insert it fully into the skirt holding bracket.
4. Move the back end of the skirt downward and toward the outside frame until the skirt snaps in place.
5. Install the access cover.

### 3.13 EMERGENCY OPERATION

Pressing the PAUSE pushbutton is considered the normal procedure for stopping a printing operation. If this action fails, remove ac power to the printer by opening the associated circuit breaker (Appendix D).

### 3.14 DE-ENERGIZING THE PRINTER ASSEMBLY

For normal removal of power from the printer system, open the associated circuit breaker. Do not open the circuit breaker or remove primary ac power while the machine is printing. Wait at least 5 seconds after the last message is printed.



## CHAPTER 4 PROGRAMMING

### 4.1 GENERAL

This chapter contains detailed information for programming LQP8 Printer Systems. In addition to a tabulation of specific address assignments and bit definitions, two sample programs are included. These programs illustrate the different functions that can be programmed in a typical word-processing application. The logic and timing involved in the execution of the instructions are covered in Chapter 5.

### 4.2 CONTROLLER INTERFACE SIGNALS

Figure 4-1 identifies the various interface signals between the Omnibus, the LQP8-E controller, and the LQP01 printer. The manner and sequence in which these signals are asserted determine the different modes of printer operation.

In a typical word processing application, where continuous text is to be printed, the programming sequence is generally as follows:

1. The system is initialized, returning the printer carriage to the leftmost position.
2. The printer status lines are sampled.
3. The single-colored ribbon is lifted.
4. The first data character is strobed into the printer and printed.
5. The carriage is moved to the next position.
6. The second character is printed, and so forth.
7. At the end of the line, the paper is moved upward (or backward) as in a regular line feed.
8. The carriage either remains at the right end to print the next line from right to left, or is programmed to return to the leftmost position so that printing again occurs from left to right.

Any number of variations to the aforementioned sequence are possible, depending on the way in which the Input/Output Transfer (IOT) instructions are programmed.

Omnibus interface signals are described in the appropriate PDP-8 manual. Printer interface signals are covered in detail in Chapter 5 of this manual. Bit configurations at the output of the controller status register (LQPSR) are illustrated in Figure 4-2 and described in Table 4-1. Data transfer from controller to accumulator (AC) occurs during execution of an IOT 6505 instruction. The controller data buffer (LQPIBH) merely stores a 12-bit data word and can be interrogated by an IOT 6501 instruction, if required.

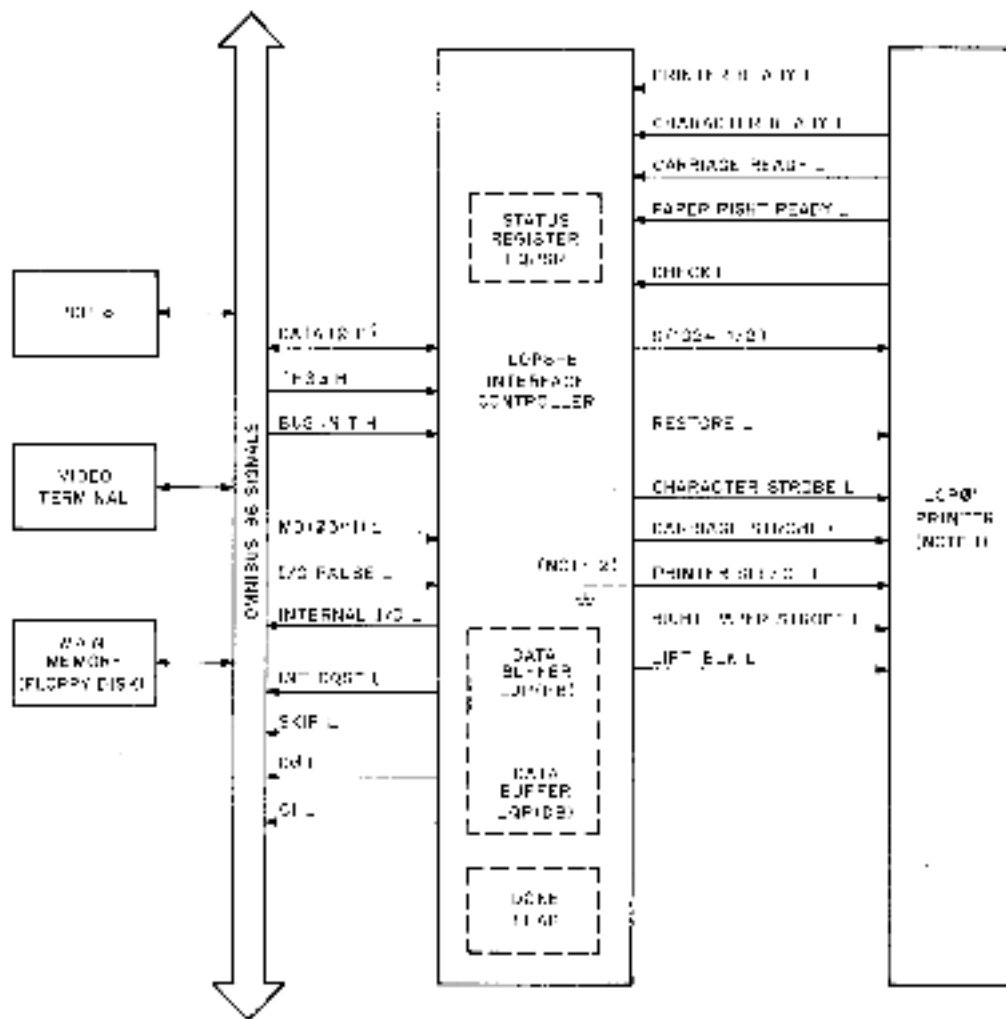

- NOTE:
1. Only those printer signals actually connected are shown on this diagram.
  2. The PRINTER SELECT line is grounded and the effect is always asserted.

4-1-100

Figure 4-1 Controller Interface Signals

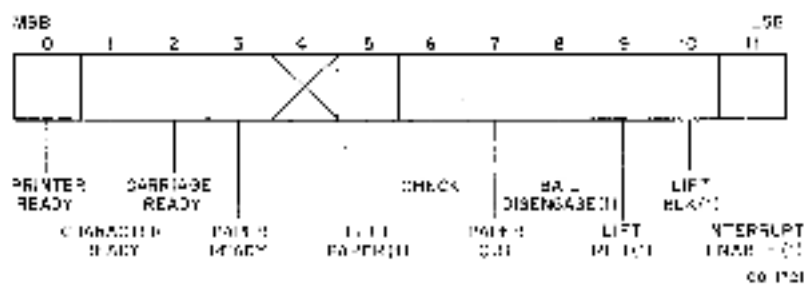

Figure 4-2 LQPSR Bit Interpretation

Table 4-1 Bit Description for LQPSR

Data Bit	Name	Description
0	PRINTER READY	When set, this bit indicates that the printer is properly supplied with power and no internal malfunctions exist. During restore, this bit is cleared. This is a read-only bit.
1	CHARACTER READY	When set, this bit indicates that the printer is ready to accept a print command. This is a read-only bit.
2	CARRIAGE READY	When set, this bit indicates that the printer is ready to accept a carriage motion command. This is a read-only bit.
3	PAPER READY	When set, this bit indicates that the printer is ready to accept a paper motion command. This is a read-only bit.
4	UNUSED	
5	LEFT PAPER (1)	When cleared, this bit enables the RIGHT PAPER STROBE.
6	CHECK	When set, this bit indicates that an internal malfunction exists within the printer mechanism, or the power supply has gone out of tolerance, and will clear all the printer READY status lines (LQPSR bits 0, 1, 2, and 3). If this condition was caused by improper programming or by a transient error condition, this bit must be cleared by IOT or system reset before the printer will execute any further commands. This is a read-only bit. If a permanent error exists, this bit cannot be cleared and corrective maintenance must be performed.
7	PAPER OUT	Not used.
8	BAIL DISENGAGE	Not used.
9	LEFT RED (1)	Not used.
10	LEFT BLK (1)	When set, this bit indicates that single-color ribbon has been raised into position for printing. When not set, it indicates that the ribbon has been lowered.
11	INTERRUPT ENABLE	When set, this bit enables an interrupt request to the PDP-8 processor upon setting of the internal controller DONE flag.

### 4.3 IOT INSTRUCTIONS

LQP01 operation is controlled by eight different IOT instructions. The format of a typical IOT instruction is shown in Figure 4-3. Bits 0-2 contain the op code, which must be octal 6 to specify an IOT instruction on the PDP-8. Bits 3-8 contain the device selection code that is transmitted to every peripheral device whenever the IOT instruction is executed. The LQP8 Printer System can be configured to recognize codes in the range of 00<sub>3</sub>-77<sub>8</sub>. The standard configuration has a device code of 50<sub>3</sub>. The last three bits of the IOT instruction (bits 9-11) contain the operation specification code. These bits are used to specify the eight different printer operations:

Standard IOT	Function	Mnemonic
6500	Skip on DONE flag	LQSK
6501	Read controller data buffer (LQPDB) into AC	LQRB
6502	Move paper and clear DONE flag	LQMP
6503	Move carriage and clear DONE flag	LQMC
6504	Print character and clear DONE flag	LQPC
6505	Read controller status (LQPSR) into AC and clear DONE flag	LQRS
6506	Write status (LQPSR) from AC and set DONE flag	LQLS
6507	Restore printer and clear DONE flag	LQRE

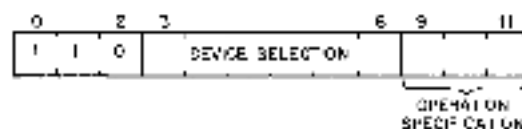

Figure 4-3 IOT Instruction Format

A detailed description of each IOT instruction is presented in Table 4-2.

Table 4-2 Functional Description of IOT Instructions

IOT Instruction	Functional Description
6500	<p><b>Skip on DONE Flag</b>            Enables program to skip the next instruction if the internal controller DONE flag is set. This flag may be set in a number of ways as described by the following IOTs.</p>
6501	<p><b>Read Data Buffer (LQIDB) into AC</b>            First clears the PDP-8 AC, then transfers the current contents of the controller data buffer (LQIDB) to the AC.</p>
6502	<p><b>Move Paper and Clear DONE Flag</b>            Causes the platen to move the paper a selected distance and direction in increments of 1.22 cm (1/48 in). To produce paper motion, the AC is first loaded with a binary word in bit positions 1-10, indicating a relative displacement of paper in multiples of 1.22 cm (1/48 in) (Figure 4-4). Bit 10 is the least significant bit and bit 11 is unused. Bit 0 indicates the direction of movement. Setting bit 0 = 1 reverses paper motion; setting bit 0 = 0 advances the paper.</p> <p>When the IOT is issued, the contents of the AC are transferred to the data buffer (LQIDB), the AC is cleared, the controller DONE flag is cleared, and the printer is given the paper motion command. The printer will immediately negate its PAPER READY line [bit 3 of status register (LQPSR)] and ignore any further paper motion commands. Upon completion of the paper movement, the PAPER READY bit will be asserted and set the internal DONE flag.</p> <p style="text-align: center;"><b>NOTE</b>            The user system must keep track of paper positioning.</p>
6503	<p><b>Move Carriage and Clear DONE Flag</b>            Causes the carriage to move a selected distance and direction in increments of 0.3048 cm (1/120 in). To produce carriage motion, the AC is first loaded with a binary word in bits 1-11, indicating the relative displacement of carriage motion in multiples of 0.3048 cm (1/120 in) (Figure 4-5). Bit 11 is the least significant bit. Bit 0 indicates the direction of carriage motion. Setting bit 0 = 1 moves the carriage to the left; setting bit 0 = 0 moves the carriage to the right.</p>

Table 4-2 Functional Description of IOT Instructions (Cont)

IOT Instruction	Functional Description
	<p>When this IOT is issued, the contents of the AC are transferred to the data buffer (LQPD8), the AC is cleared, the DONE flag is cleared, and the printer is given the carriage motion command. The printer will immediately negate its CARRIAGE READY line [bit 2 of status register (LQPSR)] and ignore any further carriage motion commands. Upon completion of carriage movement, the CARRIAGE READY bit will be asserted and set the internal DONE flag.</p> <p style="text-align: center;"><b>NOTE</b></p> <p>The user system must continually update itself as to carriage position for proper control of carriage motion, particularly for carriage return. Otherwise, the carriage may crash into the left/right stops and a CHECK error will be granted.</p>
6504	<p><b>Print Character and Clear DONE Flag</b>            Causes a selected character to be printed. To print a character, the AC is first loaded with the binary code for one of 96 available characters in a modified ASCII format in bit positions 4-10 (Figure 4-6). Bit 10 is the least significant bit. Bits 0, 1, 2, 3, and 11 are unused. When the IOT is issued, the contents of the AC are transferred to the data buffer (LQPD8), the AC is cleared, the DONE flag is cleared, and the printer is given the print character command. The printer will immediately negate its CHARACTER READY line [bit 1 of status register (LQPSR)] and ignore any further print character commands. Upon completion of the printing operation, the CHARACTER READY bit will be asserted and set the internal DONE flag.</p>
6505	<p><b>Read Status (LQPSR) into AC and Clear DONE Flag</b>            Transfers the contents of the status register (LQPSR) into the AC and then clears the internal DONE flag.</p>
6506	<p><b>Write Status (LQPSR) from AC and Set DONE Flag</b>            Transfers current contents of AC into the controller status register (LQPSR) and clears AC. Of 12 data bits, only 5 are stored in the printer buffer (LQPP8) and also transferred to the status register (LQPSR); these are data bits 5, 8, 9, 10, and 11. At the same time, the DONE flag is set. Any printer operations that take place depend on the status of the data lines. If data bit 10 is asserted, the LIFT BLK (1) status line (bit 10 of LQPSR) is asserted and the printer ribbon is lifted to the up position. If data bit 11 is asserted, then the INT ENBL (1) flag (bit 11 of LQPSR) is asserted. When the INT ENBL (1) and DONE flags are both set at the same time, then the Omnibus signal labeled INT RQST (Interrupt Request) is asserted. The ribbon will remain in the up position and/or the INT ENBL (1) flag will be set until: (1) the controller is initialized; or (2) another IOT 6506 instruction is programmed with a different data word. In this case, the Omnibus interrupt request will not change.</p>

Table 4-2 Functional Description of IOT Instructions (Cont)

IOT Instruction	Functional Description
6507	<p><b>Restore Printer and Clear DONE Flag</b>            Clears a transient error condition within the printer (bit 6 of LQPSR) and moves the carriage to the leftmost position. Upon receipt of the Restore command, the DONE flag is cleared and the printer negates all of its READY status lines (bits 0, 1, 2, 3 of LQPSR) while the carriage is positioning to its home position. Because of the slow speed of the carriage movement during a restore, this IOT should not be used as a carriage return. The contents of the AC are both unaltered and unused by the restore IOT. Upon completion of the Restore operation, the printer asserts all its READY lines and the internal DONE flag is set.</p> <p>The Restore operation also occurs whenever a system INITIALIZE pulse is sent by the processor. This feature can be deleted, if desired, by removal of jumper W7 on the M8366 controller module.</p> <p style="text-align: center;"><b>NOTE</b></p> <p>If restore is used to clear a CHECK condition (bit 6 of LQPSR), the internal DONE flag will not be cleared and should be cleared by a Read Status instruction (IOT 6505). If CHECK is not present or if the restore is caused by a system INIT, DONE will be cleared.</p>

**Example: Programming Paper Motion**

An example for paper motion is shown below. To move the platen upward 1.27 cm (1/2 in); first find the total number of increments required:

$$\begin{aligned}
 X &= 1.27 \text{ cm (0.5 in) (48 increments/inch)} \\
 &= 24 \text{ increments (base 10)}
 \end{aligned}$$

Convert the number of increments from decimal to octal code, then code bit 0 for direction, thusly:

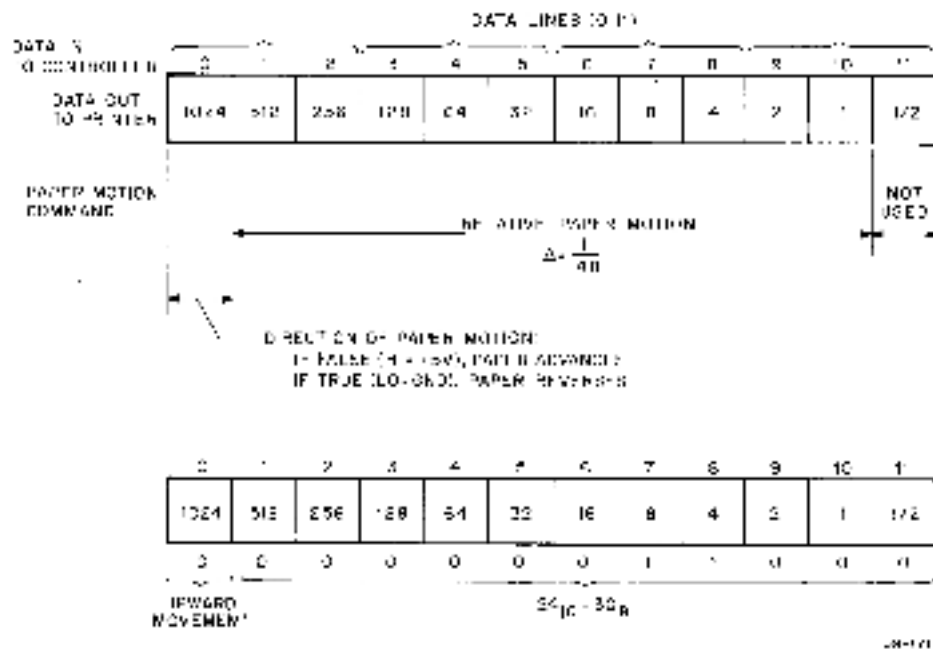

Figure 4-4 Programming Paper Motion

### Example: Programming Carriage Motion

An example for carriage motion is shown below.

To move the carriage 15.24 cm (6 in) to the right, first find the total number of increments required:

$$\begin{aligned} X &= 15.24 \text{ cm (6 in) (120 increments/inch)} \\ &= 720 \text{ increments (base 10)} \end{aligned}$$

Convert the number of increments from decimal to octal code, then code bit 0 for direction, thusly:

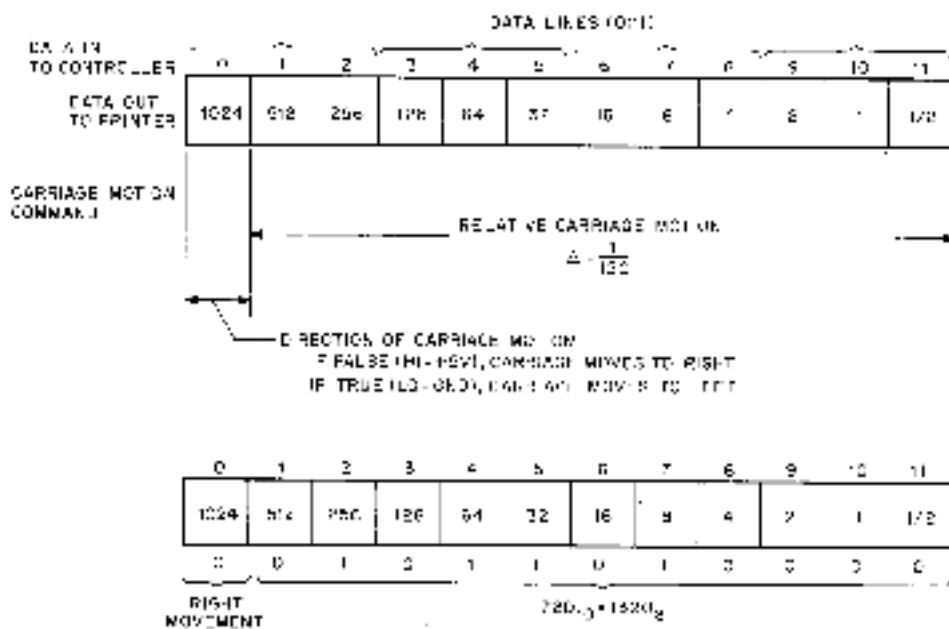

Figure 4-5 Programming Carriage Motion

**Example: Programming Printer Commands**

An example for printing a character is shown below.

To print the uppercase letter A, first find the modified ASCII code in Appendix A. In this case, the code is 0202<sub>h</sub>, and is programmed as follows:

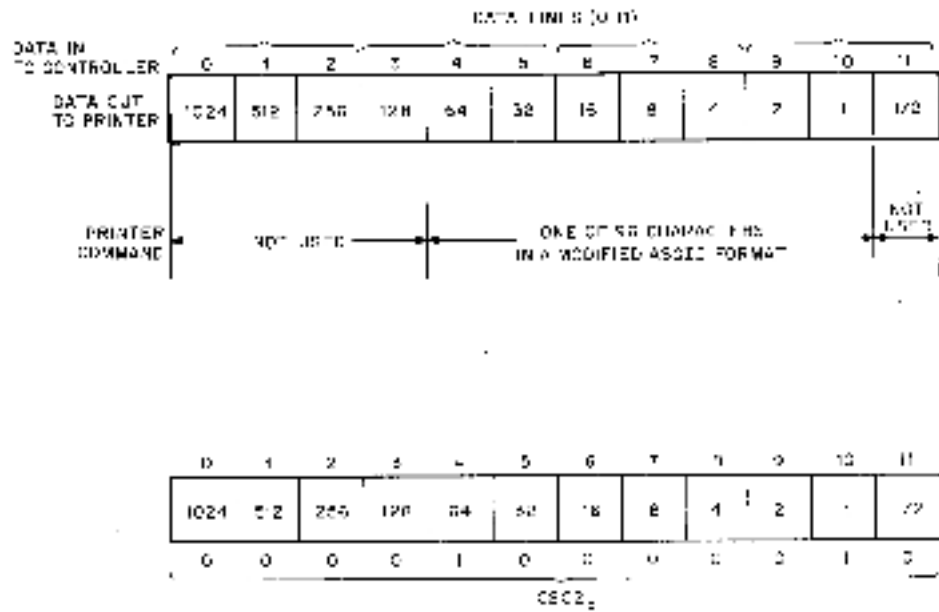

Figure 4-6 Programming Printer Commands

**4.4 PROGRAMMING CONSIDERATIONS**

The following conditions should be considered when programming the printer system:

**Overlap** – System throughput can be improved greatly by overlapping commands to the printer. The printing, carriage motion, and paper motion hardware are each independently selected and controlled to allow more than one operation to be in process at any given time. Only the actual firing of the print hammer is interlocked with carriage and paper motion. This allows the user to give a paper motion command, carriage motion command, and print character command in rapid succession. This will start the carriage, platen, and print wheel into simultaneous motion. If the print wheel positions properly prior to completion of carriage and platen motion, the print hammer will wait until all motion stops before firing. Care should be taken when interpreting interrupts. In this case, an interrupt can only indicate that the printer status has changed since the last examination of the LQPSR and any subsequent commands must be based on the change in status. Printer operations will actually occur in the same order that they are given.

**Ribbon Lift** – The print hammer is interlocked with ribbon motion to inhibit the execution of either of these functions while the other is in progress. This allows the acceptance of a ribbon lift followed immediately by a print character or a print character followed immediately by a ribbon drop without fear of misprinting a character.

**DONE Flag** - In addition to those conditions already defined in Table 4-2, the following conditions will set the internal DONE flag:

- PAPER OUT (bit 7 of LQPSR) being asserted.
- PRINTER READY (bit 0 of LQPSR) being negated.
- CHECK (bit 6 of LQPSR) being asserted.

**Ribbon Out** - The printer is equipped with a ribbon out detector to prevent the deterioration of print quality on an unattended machine. If a mylar ribbon (with an end-of-ribbon sensor) is exhausted, the CHARACTER READY bit (bit 1 of LQPSR) will be negated and the printer will not accept any print character commands until the ribbon is replaced.

#### 4.5 PROGRAMMING EXAMPLES

Figures 4-7 and 4-8 illustrate the programming involved when an LQP8 Printer System is used in conjunction with a DIGITAL DS310-W Word Processing System.

	PAL10	V1124	L-PAR-76	SEISE	PAGE 1-1
55	2216	127E		TAD	SPACE /SET CARRIAGE MOVEMENT MAGNITUDE
57	2237	6503		LQPC	/ISSUE MOVE CARRIAGE 10"
55	2216	127E		TAD	/SET CARRIAGE MOVEMENT MAGNITUDE
59	2241	127E		TAD	/ADD CURRENT CARRIAGE POSITION
67	2252	227E		BCA	/UPDATE CARRIAGE POSITION POINTER
61	2243	5217		JMP	/CONTINUE PRINTING CURRENT LINE
62			/		
63	2249	7513	ORLF,	CLA CLL 140 WTR	/SET BIT ZERO FOR LEFT MOVEMENT
64	2245	3E7E		TAD	/ADD CARRIAGE POSITION
65	2245	55F3		LQPC	/MOVE CARRIAGE TO COLUMN 8
66	2247	6505		LQPS	/READ STATUS SENSOR
67	2252	2275		AND	/MASK BIT ONE
68	2251	1274		XAD	/XOR COMPLEMENT OF PAPER READY
69	2452	7A08		STA CLA	/SKIP IF PAPER READY = 1
70	2253	5247		JMP	/WAIT FOR PAPER READY
71	2254	1271		TAD	/SET PAPER FEED MAGNITUDE
72	2255	4C9E		LQPP	/ISSUE MOVE PAPER 10"
73	2256	73F5		CLA CLL 140 HAL	/SET BIT 10
74	2257	1265		TAD	/ADD CHARACTER CODE
75	2262	2255		BCA	/UPDATE TO NEXT CHARACTER
76	2241	227E		BCA	/CLEAN CARRIAGE POSITION POINTER
77	2242	2267		INCRT	/INCREMENT LINE COUNT
78	2243	5214		JMP	/CONTINUE WITH NEXT LINE
79	2244	520E		JMP	/START OVER
80			/		
81	2265	2306	CHAR,	2	/STORE AREA OF CHARACTER TO PRINT
82	2266	230F	CHARCT,	8	/CHARACTER COUNTER
83	2267	230V	LINECT,	8	/LINE COUNTER
84	2270	2314	SPACE,	2314	/CHARACTER SPACING MAGNITUDE
85	2271	2326	LINE,	2326	/LINE SPACING MAGNITUDE
86	2272	2328	SAVPOS,	A	/CARRIAGE POSITION POINTER
87	2273	2324	LENGTH,	2324	/NUMBER OF CHARACTERS PER LINE
88	2274	7420	K1400,	7420	
89	2275	2420	K1401,	2420	
90	2276	2190	K1000,	2190	
91	2277	2020	K2000,	2020	
92	2300	6402	N0300,	6402	
93	2301	1002	K1300,	1002	
94	2302	7402	X7300,	7402	
95	2303	7542	4100,	7542	
96			/		
97			/		
98			SEN		

Figure 4-7 Programming Example No. 1 (Sheet 1 of 2)

```

1 /
2 /
3 /LOP=5 PROGRAMMING EXAMPLE #1
4 /
5 /
6 /
7 /THIS PROGRAM PRINTS ONE LINE (132 COLUMNS) OF EACH OF THE
8 /86 PRINTABLE CHARACTERS USING THE STATUS REGISTER READY BITS
9 /TO INDICATE WHEN THE PRINTER IS READY TO ACCEPT A COMMAND.
10 /THIS METHOD RESULTS IN MAXIMUM THROUGHPUT SINCE COMMANDS
11 /ARE OVERLAPPED AND ARE INDEPENDENT OF ALL OTHER READY BITS.
12 /
13 /
14 6572 LGRS=6508 /SKIP IN DONE FLAG
15 6571 LGRS=6501 /READ DATA BUFFER
16 6568 LGRS=6502 /MOVE PAPER
17 6527 LGRS=6503 /MOVE CARRIAGE
18 6504 LGRS=6504 /PRINT CHARACTER
19 6505 LGRS=6505 /READ STATUS REGISTER
20 6506 LGRS=6506 /LOAD STATUS REGISTER
21 6507 LGRS=6507 /RESTORE PRINTER
22 /
23 /
24 8202 *END
25 /
26 8208 6507 /RESTORE PRINTER
27 8201 6508 /LOAD STATUS REGISTER
28 8202 8274 AND RTIME /MASK READY BITS
29 8203 1272 AND RADD /AND COMPLEMENT OF ALL READY
30 8204 7432 ORA CL4 /OR IN RESTORE COMPLETE
31 8205 5001 JPR /WAIT FOR RESTORE COMPLETE
32 8206 1876 AND R100 /AND FIRST ASCII CODE
33 8207 5005 ORA ORAM /OR IN FOR PRINTING
34 8210 7392 CL4 CLL IAC PAL /SET NOT 10
35 8211 6576 CLR8 /LEFT RIBBON
36 8212 1323 TAD N100 /SET NUMBER OF LINES TO PRINT
37 8213 7267 TCR L1000 /SET UP LINE COUNTER
38 8214 1273 TAD LLASTH /SET NUMBER OF CHARACTERS PER LINE
39 8215 7841 CLR /GENERATE IT
40 8216 7266 ORA CTRCNT /SET UP CHARACTER COUNTER
41 8217 6505 PRNTLPA LGRS /READ STATUS REGISTER
42 8208 8277 AND R200 /MASK BIT ONE
43 8211 1517 TAD R200 /AND COMPLEMENT OF CHARACTER READY
44 8212 7542 ORA CL4 /OR IN IF CHARACTER READY = 1
45 8213 5217 JPR /WAIT FOR CHARACTER READY
46 8214 1265 TAD CTRCNT /GET CHARACTER TO PRINT
47 8215 6504 LGRS /ISSUE PRINT CHARACTER CMD
48 8216 6505 LGRS /READ STATUS REGISTER
49 8217 2501 AND R1002 /MASK BIT 2
50 8218 1542 TAD R1002 /AND COMPLEMENT OF CARRIAGE READY
51 8219 7842 ORA CL4 /OR IN IF CARRIAGE READY = 1
52 8220 5220 JPR /WAIT FOR CARRIAGE READY
53 8221 2506 JCR /INCREMENT CHARACTER COUNTER
54 8224 7432 AND R100 /SKIP IF NOT END OF LINE
55 8225 5244 JPR /END OF LINE

```

Figure 4-7 Programming Example No. 1 (Sheet 2 of 2)

```

PAGE 1  V14E4  4-MAR-76  13:57  PAGE 1

1 /
2 /
3 /ZLCP-5 PROGRAMMING EXAMPLE #2/
4 /
5 /
6 /THIS PROGRAM PRINTS ONE LINE (132 COLUMNS) OF EACH OF THE
7 /96 PRINTABLE CHARACTERS USING THE DONE FLAG C INDICATE
8 /WHEN THE CURRENT POSITION OPERATION IS COMPLETE. THIS METHOD RESULTS
9 /IN A SLOWER PRINTING SPEED SINCE THE PRINTER COMMANDS ARE NOT
10 /OVERLAPPED. A CHECK OF THE DATA BUFFER IS MADE AFTER EACH COMMAND TO
11 /ENSURE THAT THE CORRECT DATA HAS LOADED IN EACH CASE. ANY ERROR
12 /WILL RESULT IN A PROGRAM HALT.
13 /
14 /
15 /
16 /
17 0540 LCRP=0540 /SKIP ON DONE FLAG
18 0541 LCRP=0541 /READ DATA BUFFER
19 0542 LCP=0502 /MOVE PAPER
20 0535 LCP=0502 /MOVE CARRIAGE
21 0520 LCP=0500 /PRINT CHARACTER
22 0505 LCRS=0505 /READ STATUS REGISTER
23 0500 LCLSR=0500 /LOAD STATUS REGISTER
24 0507 LCRP=0507 /RESTORE PRINTER
25 /
26 /
27 0240 *ERR
28 /
29 /
30 0240 0507 BEGIN, LCRP /RESTORE PRINTER
31 0271 0509 LCRS /READ STATUS REGISTER
32 0202 0510 AND R7000 /MASK READY BITS
33 0205 1001 TAD R400 /ADD COMPLEMENT OF ALL READY
34 0204 7000 SYA CLA /SKIP IF ALL READY
35 0208 0201 JNF BEGIN+1 /WAIT FOR READY BIT
36 0206 1307 TAD R100 /GET FIRST CHARACTER CODE
37 0207 0302 DCA CHAR /SAVE FOR PRINTING
38 0212 7005 CLA CLL TAD R40 /SET BIT IN
39 0211 0500 LDIR /LEFT FIELD
40 0212 1305 TAD LENGTH /GET LINE LENGTH, NUMBER OF CHARACTERS
41 0213 7001 DCA /RESERVE IT
42 0214 0301 DCA CHRCNT /GET LP CHARACTER COUNTER
43 0215 1300 BEGINLP, TAD CHAR /GET CHARACTER TO PRINT
44 0216 0214 LCRP /PRINT CHARACTER
45 0217 1302 TAD CHAR /GET CODE SENT
46 0220 7001 DCA /RESERVE FOR CHECKING DATA BUFFER
47 0221 0307 DCA SAVEIF /SAVE FOR CHECKING DATA BUFFER
48 0222 0501 LCRP /READ DATA BUFFER
49 0223 1307 TAD SAVEIF /ADD DATA CHECK VALUE
50 0224 7000 D2A CLA /SKIP IF DATA SENT = DATA READ
51 0225 0272 JNF ERROR /GO TO ERROR ROUTINE
52 0226 0500 LCRP /TEST DONE FLAG
53 0227 0225 DCA /WAIT FOR DONE FLAG
54 0230 0301 ISZ CHRCNT /INCREMENT CHARACTER COUNT
55 0231 7410 BRP /SKIP IF NOT END OF LINE

```

Figure 4-8 Programming Example No. 2 (Sheet 1 of 2)

```

PAL13  Y1424  L=PAR=76  L0157  PAGE 1-1

76  0237  6252          JNF  CHLF  /END OF LINE
77  0238  1321          TAO  SPACE  /SET CHARACTER SPACING MAGNITUDE
78  0239  4523          LINC  /MOVE CARRIAGE
79  0239  1321          TAO  SPACE  /SET CHARACTER SPACING MAGNITUDE
80  0236  7041          CIA  /MAGNIF FOR DATA BUFFER CHECK
81  0237  3387          COA  SAVBUF  /SAVE FOR CHECKING DATA BUFFER
82  0240  6521          LDRB  /READ DATA BUFFER
83  0241  1327          TAO  SAVBUF  /ADD DATA CHECK VALUE
84  0242  7440          SZ4  CLA  /SKIP IF DATA SENT = 0%, READ
85  0243  5272          JPP  ERROR  /GO TO ERROR ROUTINE
86  0244  6523          LDRB  /TEST DONE FLAG
87  0245  5244          JPP  J=1  /ACT FOR DONE FLAG
88  0246  1323          TAO  SPACE  /SET CHARACTER SPACING MAGNITUDE
89  0247  1325          TAO  SAVPOS  /ADD CURRENT CARRIAGE POSITION
90  0250  1325          COA  SAVPOS  /SAVE NEW CARRIAGE POSN IN
91  0251  5215          JPP  PRINTP  /CONTINUE WITH CURRENT LINE
92
93  0252  7213          /
94  0253  1325          DRLF  CLA  CLL  IAC  WTR  /SET BIT ZERO
95  0254  5423          TAO  SAVPOS  /ADD CURRENT CARRIAGE POSITION
96  0255  5423          LDRB  /MOVE CARRIAGE LEFT TO COLUMN R
97  0256  5420          LDRB  /TEST DONE FLAG
98  0256  5455          JPP  J=1  /ACT FOR DONE FLAG
99  0257  1374          TAO  LINE  /SET PAPER FOLD POSITION
100  0260  5420          LDRB  /ADVANCE PAPER TO NEXT LINE
101  0261  5413          LDRB  /TEST DONE FLAG
102  0262  5427          JPP  J=1  /ACT FOR DONE FLAG
103  0263  7225          CLA  CLL  IAC  RAL  /SET BIT 15
104  0264  1323          TAO  CHAR  /ADD CURRENT CHARACTER CODE
105  0265  5374          COA  CHAR  /SAVE NEW CHARACTER CODE
106  0266  5365          COA  SAVPOS  /UPDATE CARRIAGE POSITION POINTER
107  0267  2328          ITC  LINCNT  /INCREMENT LINE COUNTER
108  0270  5212          JNF  PRINTP=3  /CONTINUE WITH NEXT LINE
109  0271  5200          JMP  6214  /START OVER
110
111
112
113
114
115
116
117
118
119
120
121
122
123
124
125
126
127
128
129
130
131
132
133
134
135
136
137
138
139
140
141
142
143
144
145
146
147
148
149
150
151
152
153
154
155
156
157
158
159
160
161
162
163
164
165
166
167
168
169
170
171
172
173
174
175
176
177
178
179
180
181
182
183
184
185
186
187
188
189
190
191
192
193
194
195
196
197
198
199
200
201
202
203
204
205
206
207
208
209
210
211
212
213
214
215
216
217
218
219
220
221
222
223
224
225
226
227
228
229
230
231
232
233
234
235
236
237
238
239
240
241
242
243
244
245
246
247
248
249
250
251
252
253
254
255
256
257
258
259
260
261
262
263
264
265
266
267
268
269
270
271
272
273
274
275
276
277
278
279
280
281
282
283
284
285
286
287
288
289
290
291
292
293
294
295
296
297
298
299
300
301
302
303
304
305
306
307
308
309
310
311
312
313
314
315
316
317
318
319
320
321
322
323
324
325
326
327
328
329
330
331
332
333
334
335
336
337
338
339
340
341
342
343
344
345
346
347
348
349
350
351
352
353
354
355
356
357
358
359
360
361
362
363
364
365
366
367
368
369
370
371
372
373
374
375
376
377
378
379
380
381
382
383
384
385
386
387
388
389
390
391
392
393
394
395
396
397
398
399
400
401
402
403
404
405
406
407
408
409
410
411
412
413
414
415
416
417
418
419
420
421
422
423
424
425
426
427
428
429
430
431
432
433
434
435
436
437
438
439
440
441
442
443
444
445
446
447
448
449
450
451
452
453
454
455
456
457
458
459
460
461
462
463
464
465
466
467
468
469
470
471
472
473
474
475
476
477
478
479
480
481
482
483
484
485
486
487
488
489
490
491
492
493
494
495
496
497
498
499
500
501
502
503
504
505
506
507
508
509
510
511
512
513
514
515
516
517
518
519
520
521
522
523
524
525
526
527
528
529
530
531
532
533
534
535
536
537
538
539
540
541
542
543
544
545
546
547
548
549
550
551
552
553
554
555
556
557
558
559
560
561
562
563
564
565
566
567
568
569
570
571
572
573
574
575
576
577
578
579
580
581
582
583
584
585
586
587
588
589
590
591
592
593
594
595
596
597
598
599
600
601
602
603
604
605
606
607
608
609
610
611
612
613
614
615
616
617
618
619
620
621
622
623
624
625
626
627
628
629
630
631
632
633
634
635
636
637
638
639
640
641
642
643
644
645
646
647
648
649
650
651
652
653
654
655
656
657
658
659
660
661
662
663
664
665
666
667
668
669
670
671
672
673
674
675
676
677
678
679
680
681
682
683
684
685
686
687
688
689
690
691
692
693
694
695
696
697
698
699
700
701
702
703
704
705
706
707
708
709
710
711
712
713
714
715
716
717
718
719
720
721
722
723
724
725
726
727
728
729
730
731
732
733
734
735
736
737
738
739
740
741
742
743
744
745
746
747
748
749
750
751
752
753
754
755
756
757
758
759
760
761
762
763
764
765
766
767
768
769
770
771
772
773
774
775
776
777
778
779
780
781
782
783
784
785
786
787
788
789
790
791
792
793
794
795
796
797
798
799
800
801
802
803
804
805
806
807
808
809
810
811
812
813
814
815
816
817
818
819
820
821
822
823
824
825
826
827
828
829
830
831
832
833
834
835
836
837
838
839
840
841
842
843
844
845
846
847
848
849
850
851
852
853
854
855
856
857
858
859
860
861
862
863
864
865
866
867
868
869
870
871
872
873
874
875
876
877
878
879
880
881
882
883
884
885
886
887
888
889
890
891
892
893
894
895
896
897
898
899
900
901
902
903
904
905
906
907
908
909
910
911
912
913
914
915
916
917
918
919
920
921
922
923
924
925
926
927
928
929
930
931
932
933
934
935
936
937
938
939
940
941
942
943
944
945
946
947
948
949
950
951
952
953
954
955
956
957
958
959
960
961
962
963
964
965
966
967
968
969
970
971
972
973
974
975
976
977
978
979
980
981
982
983
984
985
986
987
988
989
990
991
992
993
994
995
996
997
998
999
1000

```

```

PAL13  Y1424  M=PAR=76  L0157  PAGE 1-2

111
112
113
114
115
116
117
118
119
120
121
122
123
124
125
126
127
128
129
130
131
132
133
134
135
136
137
138
139
140
141
142
143
144
145
146
147
148
149
150
151
152
153
154
155
156
157
158
159
160
161
162
163
164
165
166
167
168
169
170
171
172
173
174
175
176
177
178
179
180
181
182
183
184
185
186
187
188
189
190
191
192
193
194
195
196
197
198
199
200
201
202
203
204
205
206
207
208
209
210
211
212
213
214
215
216
217
218
219
220
221
222
223
224
225
226
227
228
229
230
231
232
233
234
235
236
237
238
239
240
241
242
243
244
245
246
247
248
249
250
251
252
253
254
255
256
257
258
259
260
261
262
263
264
265
266
267
268
269
270
271
272
273
274
275
276
277
278
279
280
281
282
283
284
285
286
287
288
289
290
291
292
293
294
295
296
297
298
299
300
301
302
303
304
305
306
307
308
309
310
311
312
313
314
315
316
317
318
319
320
321
322
323
324
325
326
327
328
329
330
331
332
333
334
335
336
337
338
339
340
341
342
343
344
345
346
347
348
349
350
351
352
353
354
355
356
357
358
359
360
361
362
363
364
365
366
367
368
369
370
371
372
373
374
375
376
377
378
379
380
381
382
383
384
385
386
387
388
389
390
391
392
393
394
395
396
397
398
399
400
401
402
403
404
405
406
407
408
409
410
411
412
413
414
415
416
417
418
419
420
421
422
423
424
425
426
427
428
429
430
431
432
433
434
435
436
437
438
439
440
441
442
443
444
445
446
447
448
449
450
451
452
453
454
455
456
457
458
459
460
461
462
463
464
465
466
467
468
469
470
471
472
473
474
475
476
477
478
479
480
481
482
483
484
485
486
487
488
489
490
491
492
493
494
495
496
497
498
499
500
501
502
503
504
505
506
507
508
509
510
511
512
513
514
515
516
517
518
519
520
521
522
523
524
525
526
527
528
529
530
531
532
533
534
535
536
537
538
539
540
541
542
543
544
545
546
547
548
549
550
551
552
553
554
555
556
557
558
559
560
561
562
563
564
565
566
567
568
569
570
571
572
573
574
575
576
577
578
579
580
581
582
583
584
585
586
587
588
589
590
591
592
593
594
595
596
597
598
599
600
601
602
603
604
605
606
607
608
609
610
611
612
613
614
615
616
617
618
619
620
621
622
623
624
625
626
627
628
629
630
631
632
633
634
635
636
637
638
639
640
641
642
643
644
645
646
647
648
649
650
651
652
653
654
655
656
657
658
659
660
661
662
663
664
665
666
667
668
669
670
671
672
673
674
675
676
677
678
679
680
681
682
683
684
685
686
687
688
689
690
691
692
693
694
695
696
697
698
699
700
701
702
703
704
705
706
707
708
709
710
711
712
713
714
715
716
717
718
719
720
721
722
723
724
725
726
727
728
729
730
731
732
733
734
735
736
737
738
739
740
741
742
743
744
745
746
747
748
749
750
751
752
753
754
755
756
757
758
759
760
761
762
763
764
765
766
767
768
769
770
771
772
773
774
775
776
777
778
779
780
781
782
783
784
785
786
787
788
789
790
791
792
793
794
795
796
797
798
799
800
801
802
803
804
805
806
807
808
809
810
811
812
813
814
815
816
817
818
819
820
821
822
823
824
825
826
827
828
829
830
831
832
833
834
835
836
837
838
839
840
841
842
843
844
845
846
847
848
849
850
851
852
853
854
855
856
857
858
859
860
861
862
863
864
865
866
867
868
869
870
871
872
873
874
875
876
877
878
879
880
881
882
883
884
885
886
887
888
889
890
891
892
893
894
895
896
897
898
899
900
901
902
903
904
905
906
907
908
909
910
911
912
913
914
915
916
917
918
919
920
921
922
923
924
925
926
927
928
929
930
931
932
933
934
935
936
937
938
939
940
941
942
943
944
945
946
947
948
949
950
951
952
953
954
955
956
957
958
959
960
961
962
963
964
965
966
967
968
969
970
971
972
973
974
975
976
977
978
979
980
981
982
983
984
985
986
987
988
989
990
991
992
993
994
995
996
997
998
999
1000

```

Figure 4-8 Programming Example No. 2 (Sheet 2 of 2)

Inputs to the printer include: 4 Strobe lines, 12 Data lines, a Printer Select line, a Top of Form line, a Bail Disengage line, and Ribbon Lift and Restore command lines. (The Top of Form line, the Bail Disengage line, the Lift Red line, and the Left Paper Strobe line are not used with the DEC DATASYSTEM 310W.) Outputs from the printer include: 5 Ready lines, a Check line, and an unused Paper Out line. All of these lines are channeled from printer connector J7 (located on top edge of the Logic 1 PCB) to connector J1 on the M8366 controller board. Power is applied to the printer from the printer power supply. Power is applied to the controller from the PDP-8 power bus.

The function of each printer interface signal is described in Table 5-2.

Table 5-2 Printer Interface Signals

Signal	Function
PRINTER SELECT Line	When TRUE (low), this signal allows the printer to respond to other input commands and enables the output status lines to the controller.
DATA Line	<p>Twelve data lines receive binary coded information which represents various operations for each printer command. These lines must be asserted at least 200 ns prior to any strobe command.</p> <p><b>Printer Commands:</b> Data lines 04 through 10 (Figure 5-1) represent one of 96 characters in a modified ASCII format. Data 04 is the most significant bit. Data 1/2 and 128 through 1024 are unused.</p> <p><b>Paper Motion Commands:</b> Data lines 01 through 10 represent a relative paper position motion in increments of 1.22 cm (1/48 in). Data 01 is the most significant bit. Data 0024 indicates the direction of paper motion. If FALSE (high), the paper advances. If TRUE (low), the paper reverses. Data 1/2 is unused.</p> <p><b>Carriage Motion Commands:</b> Data lines 01 through 11 represent a relative carriage motion in increments of 0.3048 cm (1/120 in). Data 01 is the most significant bit. Data 0024 indicates the direction of carriage motion. If FALSE (high), the carriage moves to the right. If TRUE (low), the carriage moves to the left.</p>
CHARACTER STROBE Line	This strobe pulse starts the print wheel in motion to position the selected character in front of the print hammer. When all print wheel, paper, and carriage motion has stopped, the hammer fires to print the character. Minimum pulse width is 500 ns.
CARRIAGE STROBE Line	This strobe pulse moves the carriage assembly a selected direction and distance. Minimum pulse width is 500 ns.
RIGHT PAPER STROBE Line	In the LQP01, this strobe pulse moves the entire platen a selected distance and direction. Minimum pulse width is 500 ns.
LEFT PAPER STROBE Line	(Available on special order only.)

Table 5-2 Printer Interface Signals (Cont)

Signal	Function
RESTORE Line	This strobe line causes the printer to abort all operations in process, clear any error conditions, and move the carriage to the extreme leftmost position. Minimum pulse width is 500 ns.
LIFT BLACK Line	This signal controls the print ribbon position. When LIFT BLACK is TRUE (low), the ribbon is lifted to the up position for printing in the primary ribbon color. When LIFT BLACK is FALSE (high), the ribbon is dropped to its down position for printing in the secondary color of a two-color ribbon or to provide printed character visibility for a single-color ribbon. This signal is interlocked with the character printing function. If either ribbon motion or character printing is in process, the other will not occur until the first is complete.
CHECK Line	This condition indicates that an error has occurred in the printer as a result of a malfunction or an illegal command. All machine activity is stopped and all input and output signals are disabled, except RESTORE. Only a RESTORE strobe or the removal and reapplication of printer power can clear a CHECK condition.
CHARACTER READY Line	This line indicates that the printer is ready to begin a print cycle and will go FALSE (high) while the printer is in the process of printing a character. This line is suppressed when an END OF RIBBON condition occurs.
CARRIAGE READY Line	This line indicates that the printer is ready to accept a carriage motion command. This line will go FALSE (high) while the carriage is in motion.
PAPER RIGHT READY Line	This line indicates that the printer is ready to accept a paper motion command. This line will go FALSE (high) while the platen is in motion.
PAPER LEFT READY Line	This line is always FALSE (high).
PRINTER READY Line	This line indicates that the printer is selected, is properly supplied with power, and no internal malfunction exists. The line goes FALSE during a Restore operation.
PAPER OUT Line	(In the LQPD1, this line is not used.)

#### 5.2.4 Omnibus Interface Signals

Standard PDP-8 signals interface between the Omnibus and the controller. Detailed information on the function and timing of these signals is contained in the associated PDP-8 maintenance manual.

#### 5.2.5 PDP-8 Word Structure

The PDP-8 uses 12-bit words for both data and instructions. The function of the eight IOT instructions is discussed in Chapter 4 of this manual; circuit operation during the execution of each instruction is discussed in the following paragraphs.

## 5.3 DETAILED THEORY

### 5.3.1 Basic Printer Operation

When the circuit breaker on the printer desk is closed, dc power is applied to the printer via the printer power supply. Initializing various circuits, clearing the controller DONE flag, restoring the carriage to the leftmost position, and returning the print wheel to home position is usually accomplished by either powering up the computer or (with the computer powered up) pressing the INIT key on the programmer's console. Initialization can also be accomplished by executing a Clear All Flags instruction (IOT 6407) or a Restore instruction (IOT 6507). Thereafter, the sequence of operation in a typical word processing application is generally, but not necessarily, in the following order:

1. Reading the controller status register (IOT 6505) to sample the Ready lines.
2. Lifting the single-colored ribbon (IOT 6506).
3. Printing the first character (IOT 6504).
4. Moving the carriage to the next position (IOT 6503).
5. Printing the second character (IOT 6504).
6. Moving the carriage to the next position (IOT 6503).
7. Repeating steps 2 through 6 until a complete line is printed.
8. Performing a line feed or other paper movement (IOT 6502).
9. Printing in the reverse direction (right to left) or performing a carriage return (IOT 6503) and then printing in the forward direction (left to right).

Other operations include Skip on Done (IOT 6500) and Read Data Buffer (IOT 6501).

The theory of operation of each of the eight IOT instructions is discussed in the following paragraphs.

#### NOTE

The timing relationships in Figures 5-2 through 5-7 are approximate and not necessarily drawn to scale.

### 5.3.2 Restore Printer and Clear DONE Flag (IOT 6507)

Observe the controller block diagram in Figure 5-1 and the corresponding IOT 6507 waveforms in Figure 5-2.

When the printer address is decoded, there is a match, and INTERNAL I/O L is asserted. At the same time, the lines labeled D1 IOT 7 L and D1 IOT 2, 3, 4, 7 H are asserted. When timing pulse TP3 occurs, TP03 H is asserted, so that D1 TP3 1 is asserted. The leading edge of D1 TP3 triggers the 2  $\mu$ s one-shot. The high output of the 2  $\mu$ s one-shot clocks D1 IOT 7 L into the corresponding D flip-flop, whose one output is applied to a NAND gate. The low output of the 2  $\mu$ s one-shot is labeled D3 CLEAR DONE L and is also asserted at this time, causing D5 DONE (1) H to be negated.

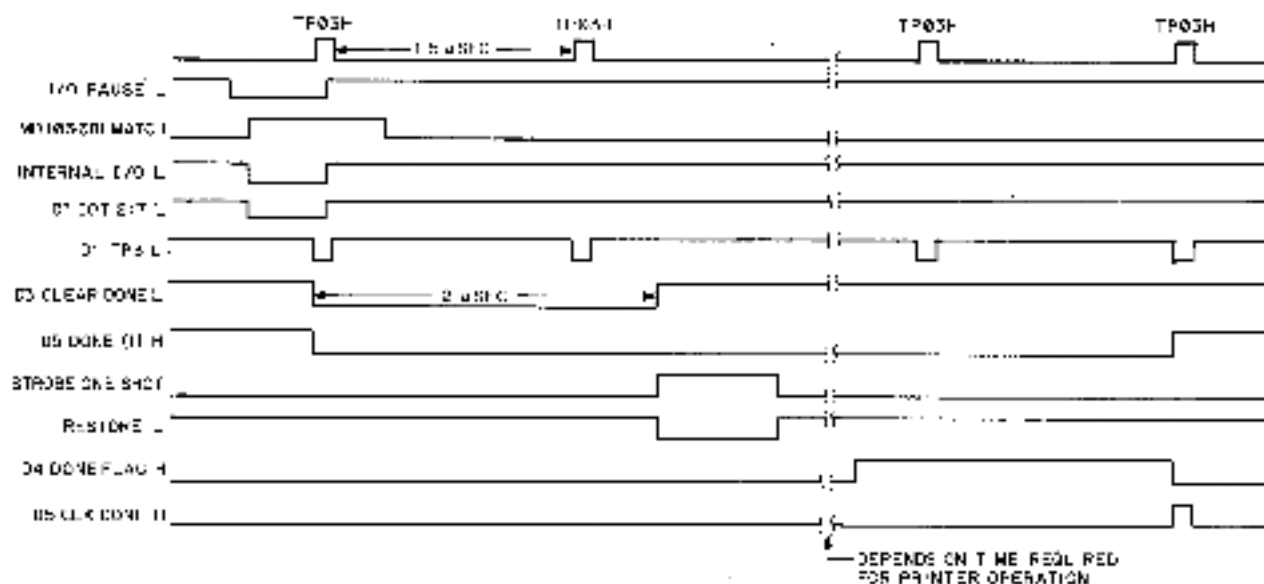

00-1017

Figure 5-2 Waveforms for IOT 6507 (Restore Function)

At the end of 2 μs, the high output of the settling delay one-shot goes low, triggering the strobe one-shot. The high output of the 500 ns one-shot gates D1 IOT 7 L into the printer as RESTORE L. The Restore strobe clears any printer error conditions and initiates movement of the carriage toward the extreme leftmost position and movement of the print wheel toward its home position. While the carriage and print wheel are moving, the printer negates all of its Ready status lines. When the strobe one-shot times out, RESTORE L is negated. Upon completion of the Restore operation, all of the printer Ready status lines are asserted. The end result is that D4 DONE FLAG H is asserted. This, in turn, enables the first of two sequentially arranged flip-flops in the sync logic (flip-flop E1-5). Setting of the first flip-flop occurs on the trailing edge of the next D1 TP3 L clock pulse and causes the second flip-flop (E1-9) to be enabled. Generation of the next D1 TP3 L clock signal now effects the following:

1. Asserts signal D5 DONE (1) H which, in turn, generates the INT RQST L signal to the PDP-8.
2. Asserts signal D5 CLR DONE H to clear the READY detect flip-flops and negate signal D4 DONE FLAG H.

Another way of restoring the printer is to assert BUS INIT H. In this case, D1 INIT L is asserted, so that RESTORE L is asserted (provided jumper W7 is installed), D5 DONE (1) H is negated, and all registers and flip-flops are cleared. When D3 LEFT PAPER (1) H goes low, the PAPER RIGHT READY L line to the status register is enabled. When BUS INIT H goes low, D1 INIT L goes high, so that RESTORE L is negated. Signal D5 DONE (1) H is asserted to generate INT RQST L in the same way as described in the preceding paragraph.

The CHECK L signal remains negated until an error or malfunction occurs, at which time it is asserted. A Restore sequence will clear a CHECK condition but will not clear signal D5 DONE (1) H (DONE flag). In this case, the DONE flag should be cleared by a Read Status instruction (IOT 6505). Removal and reapplication of printer power will also initiate the Restore sequence to clear a Check condition, but not the DONE flag.

### 5.3.3 Read Status Register (IOT 6505)

Observe the controller block diagram in Figure 5-1 and the corresponding IOT 6505 waveforms in Figure 5-3.

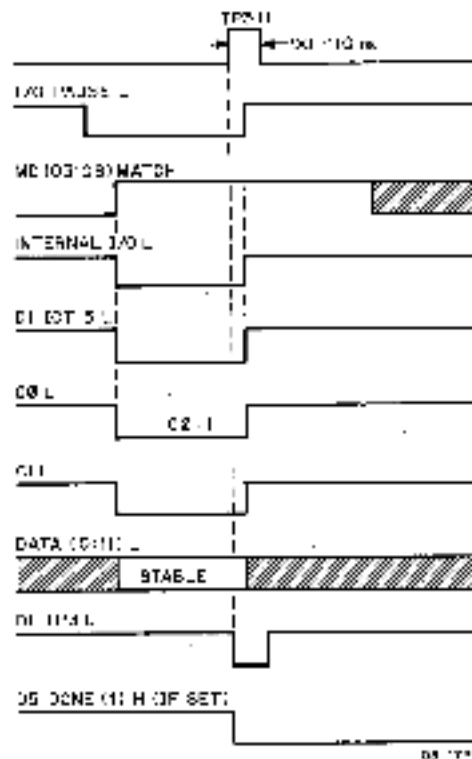

Figure 5-3 Waveforms for IOT 6505 (Read Status)

When the printer address is decoded, there is a match, and INTERNAL I/O is asserted. At the same time, D1 IOT 5 L is asserted, C0 L is asserted, and C1 L is asserted. Asserting C0 and C1 sets up the condition for transferring the data, DATA (0:11) L, to the accumulator from the controller transceivers. The actual gating of the status lines takes place when D1 IOT 5 L is asserted. Asserting D1 IOT 5 L also causes D5 DONE (1) H to be negated at clock time TP3 (D1 TP3 L asserted).

### 5.3.4 Write Status (IOT 6506)

Observe the controller block diagram in Figure 5-1 and the corresponding IOT 6506 waveforms in Figure 5-4.

When the printer address is decoded, there is a match, and INTERNAL I/O is asserted. At the same time, D1 IOT 6 L is asserted and C0 L is asserted. The combination of C0 L asserted and C1 L negated is the condition for transferring the current contents of the accumulator into the controller via the data lines, DATA (0:11) L. The data applied to the controller transceivers becomes D2 DATA (0:11). Of these 12 signals, only five are applied to the inputs of the status register flip-flops. These lines are labeled D2 DATA (5, 8, 9, 10, 11) H.

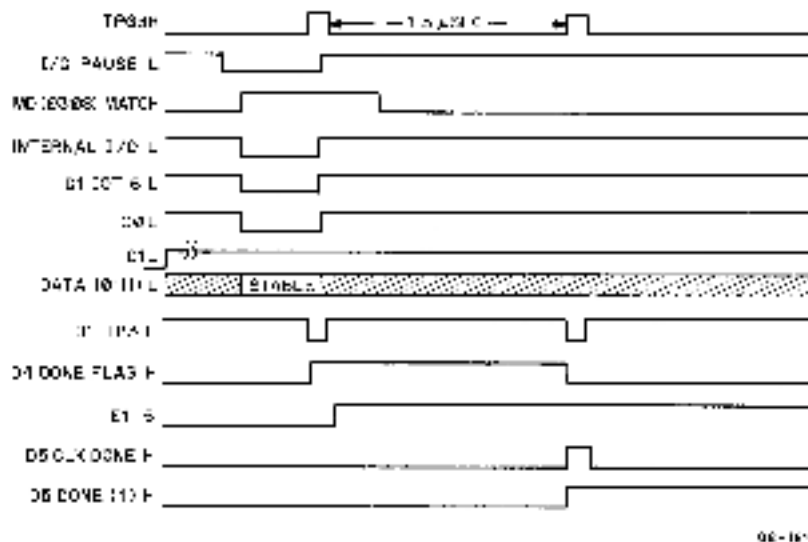

Figure 5-4 Waveforms for IOT 6506 (Load Status)

At clock time TP3, the D2 DATA signals are clocked into their corresponding status register flip-flops, and D3 SRT DONE H is asserted, so that D5 DONE (1) H is asserted. Printer operations that now take place depend on the stored content of the status register as described below:

1. If D2 DATA 10 H is asserted, then D3 LEFT BLK (1) H is now asserted, so that LEFT BLK L is asserted. When LEFT BLK L is asserted, the printer ribbon is lifted to the up position.
2. If D2 DATA 11 H is asserted, then D3 INT ENBL (1) H is asserted.
3. If D2 DATA 5 H is asserted, then D3 LEFT PAPER (1) H is asserted and D3 LEFT PAPER (0) H is negated. Similarly, if D2 DATA 8 and 9 are asserted, D3 HALF DIS-ENGAGE (1) H and D3 LIFT RED (1) H are asserted.

When D3 INT ENBL (1) H and D5 DONE (1) H are both asserted, then INT RQST L is also asserted.

### 5.3.5 Print Character (IOT 6504)

Observe the controller block diagram in Figure 5-1 and the corresponding IOT 6504 waveforms in Figure 5-5.

When the printer address is decoded, there is a match and INTERNAL I/O L is asserted. At the same time, the following signals are also asserted:

- D1 IOT 4 L
- D1 IOT 2, 3, 4 L
- D1 IOT 2, 3, 4, 7 H
- C0 L

The combination of C0 L asserted and C1 L negated is the condition for transferring the current contents of the accumulator into the controller via the data lines, DATA (0:11) L. This particular data represents a printer command (1 of 96 characters).

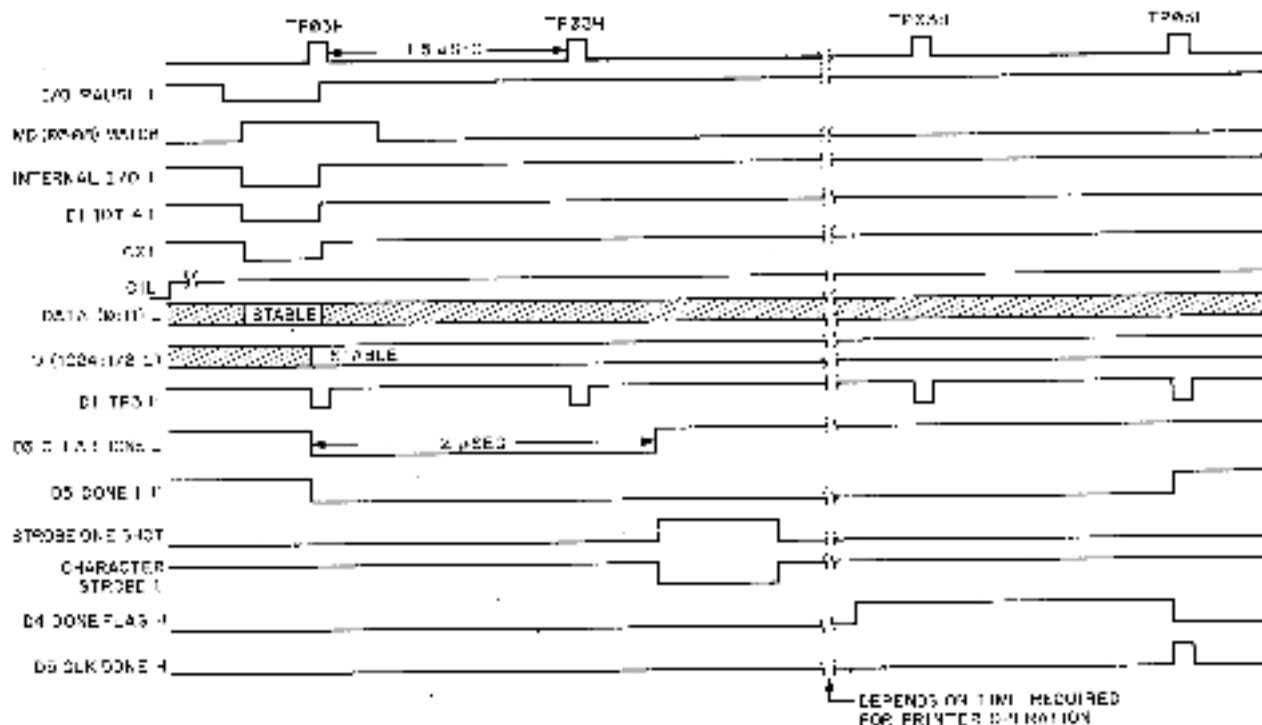

Figure 5-5 Waveforms for IOT 6504 (Print Character)

When timing pulse TP3 occurs, TP03 H is asserted, so that D1 TP3 L is asserted. The combination of D1 TP3 L and D1 IOT 2, 3, 4 L clocks the data into the LQADB data buffer, with the result that the corresponding bits of D (1024:1/2) L are asserted. In this case, D64 L is the MSB and D1 L is the LSB (Figure 4-6).

The leading edge of D1 TP3 triggers the settling delay one-shot. The high output of the settling delay one-shot clocks D1 IOT 4 L into the corresponding instruction storage flip-flop, whose one output is applied to a NAND gate. The low output of the settling delay one-shot is labeled D3 CLEAR DONE L and is also asserted at this time, causing DS DONE (1) H to be negated.

When the settling delay one-shot times out, its high output goes low, triggering the strobe one-shot. The high output of the strobe one-shot gates D1 IOT 4 L into the printer as CHARACTER STROBE L. The CHARACTER STROBE transfers the printer command into the printer. The decoded command initiates movement of the print wheel to the programmed character, whereupon the print hammer is energized to actually print the character. While the print wheel is moving, the printer negates the CHARACTER READY line and ignores any further print character commands. Upon completion of the printing operation, the CHARACTER READY bit is asserted, thereby causing D4 DONE FLAG H to be asserted. After this signal, DS DONE (1) H is generated in the same manner as described for the Restore function.

### 5.3.6 Move Carriage (IOT 6503)

Observe the controller block diagram in Figure 5-1 and the corresponding IOT 6503 waveforms in Figure 5-6.

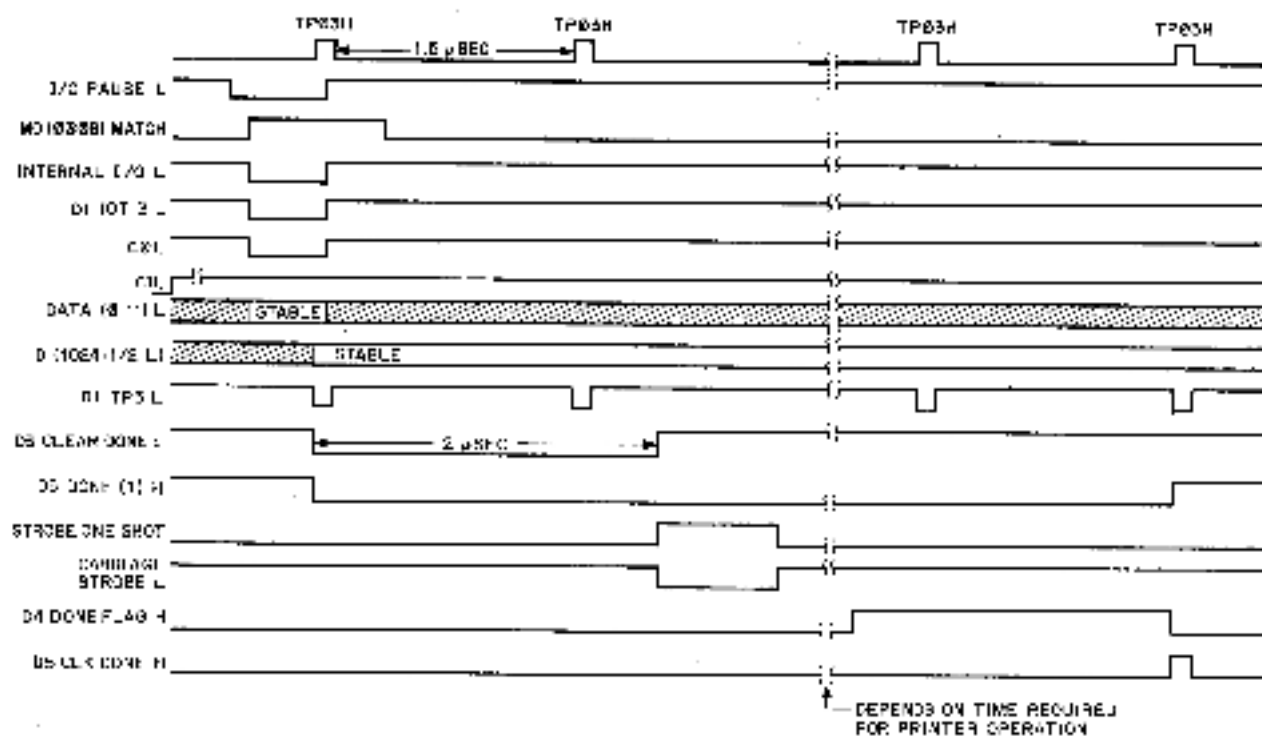

Figure 5-6 Waveforms for IOT 6503 (Carriage Motion)

Circuit operation for this instruction is the same as that for IOT 6504 (Print Character) except that CARRIAGE STROBE L is asserted and the CARRIAGE READY status line sets the DONE flag. Interpretation of the data bits for carriage movement is illustrated in Figure 4-5.

### 5.3.7 Move Paper (IOT 6502)

Observe the controller block diagram in Figure 5-1 and the corresponding IOT 6502 waveforms in Figure 5-7.

Circuit operation for this instruction is the same as that for IOT 6504 (Print Character) except that RIGHT PAPER STROBE L is asserted when the strobe one-shot is triggered and D2 DBR 11(1) H is negated, except that the PAPER RIGHT READY status line sets the DONE flag. Interpretation of the data bits for paper movement is illustrated in Figure 4-4.

### 5.3.8 Read Data Buffer into Accumulator (IOT 6501)

When the printer address is decoded there is a match, and INTERNAL I/O L is asserted (Figure 5-1). At the same time, D1 IOT 1 L is asserted, as are C0 L and C1 L. The combination of C0 L and C1 L both asserted is the condition for clearing the accumulator and then reading data from the controller data buffer into the accumulator. In this case, D2 DBR 0(1) H through D2 DBR 11(1) H are gated onto the Omnibus via the transceivers when D1 IOT 1 L goes low.

### 5.3.9 Skip on Done (IOT 6500)

When the printer address is decoded, there is a match, and INTERNAL I/O L is asserted (Figure 5-1). Concurrently, D1 IOT 0 L is asserted. If DONE is already set [D5 DONE (1) H asserted], then SKIP L is asserted and applied to the PDP-8 via the Omnibus.

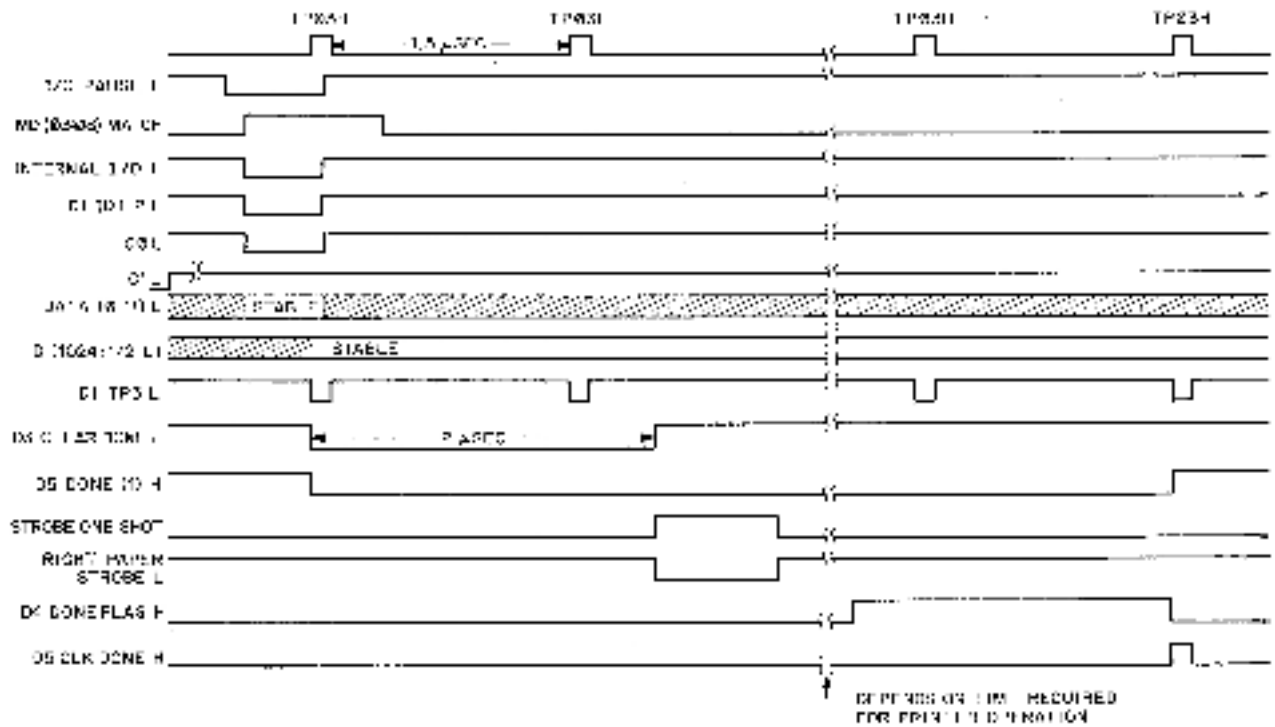

CS 15/0

Figure 5-7 Waveforms for IOT 6502 (Paper Motion)



## CHAPTER 6 SERVICE

### 6.1 INTRODUCTION

#### 6.1.1 Scope

This chapter describes preventive and corrective maintenance procedures for the LQP8-E printer. Helpful hints to facilitate fault isolation are provided, wherever possible, and step-by-step procedures to remedy field repairable malfunctions are given. Load and run procedures for the LQP8-E diagnostics are also described. A troubleshooting flowchart is provided in Appendix E as a quick reference for isolating problem areas.

#### 6.1.2 Maintenance Plan

Except for mechanical alignment, repair of the LQP8 is carried out on a module swap basis. All PCBs, as well as the carriage assembly, are field replaceable. Printers requiring re-stringing of the carriage drive cable or replacement of the carriage drive motor are to be swapped out of service and returned to a depot repair facility for repair. Preventive maintenance (cleaning and lubrication) is to be carried out on a non-scheduled basis.

#### 6.1.3 Resources

All maintenance is accomplished using the parts and materials provided in the spares kit contained at each applicable field service branch. A list of the materials included in this kit is given in Table 6-1.

**Table 6-1 Recommended LQP8 Field Service Branch Spares**

Part/Material	Part/Material
Power Amplifier PCB	Lever, Manifold
Carriage Amplifier, PCB	Hammer Energy Switch
Servo PCB	Cover Open Switch
Logic 2 PCB	Logic 1 PCB
1300 Alignment Tool	Mother PCB
T15 Torx Driver	Transducer PCB
T9 Torx Driver	Carriage Assembly
328 Lamp (6)	Shaft, Carriage
Fuse 3AG5A (3)	Hammer Armature Assembly
Fuse 3AG7A (3)	Pickup, Magnetic
Fuse GBB8 (3)	Rear Carriage Bearing
Interface Module	Ribbon Lift Assembly
Ribbon Lift Coil Assembly	Ribbon Out Sensor
Gear, 8ST Spur	Carriage Home Sensor
Platen Knob	Set Screw
Lever, Pressure Release	Bail Arm, Right
Bail Arm, Left	

## 6.2 PREVENTIVE MAINTENANCE

### 6.2.1 Preventive Maintenance Schedule

There is no rigid schedule for preventive maintenance. It is to be completed during service calls and then only when it is evident that no lubrication has been carried out in the last six months. If no service calls have been made on a given printer in a one year time period, then a special trip should be made to clean and lubricate the printer.

### 6.2.2 Materials Required

Cleaners and lubricants required for the preventive maintenance procedures are listed below.

Isopropyl Alcohol 91%	Multipurpose Lithium Grease
Molycote 557	Polyoil Type 280 (8cc)
Loctite	Thickness Gauge
Platen Cleaner 3.79 (1 gal)	Teletype Grease

### 6.2.3 Customer Performed Equipment Maintenance

Customer maintenance of the LQP8 is limited to removal of foreign materials from print wheels, platen, or ribbon lift platform. This includes foreign materials that might be introduced by spillage or dirt and dust creating factors.

### 6.2.4 Field Service Preventive Maintenance

Preventive maintenance executed by field service personnel consists of three activities: inspection, cleaning, and lubrication.

#### 6.2.4.1 Inspection - To inspect the LQP8-E printer, proceed as follows:

1. Remove power from the LQP8-E by pressing the system ON/OFF switch or by disconnecting the ac power cord going to the printer power supply (base of cabinet).
2. Remove front panel and top cover to gain access to printer mechanisms and PCBs.
3. Inspect all printer subassemblies for signs of wear and loss, broken, or charred components.
4. Check the platen system for looseness or wobble.
5. Check the carriage system for looseness, wobble, and accumulation of foreign material on the slide rails that could lead to erratic carriage movement.
6. Check the carriage drive cable thoroughly for signs of fray or wear.
7. Remove the forms tractor, platen, ribbon cartridge, and print wheel. Inspect each item for signs of wear. This completes the inspection process.

**6.2.4.2 Cleaning** - Most areas of the LQP8-E are to be cleaned using alcohol saturated wipers. Exceptions are the platen (which should be cleaned while removed from the printer), the platen pressure rollers, and paper bail tires - all of which are made of rubber. Use a platen cleaner such as Fedron to clean these parts.

When cleaning all non-rubber components, proceed as follows:

1. Using alcohol saturated wipers, thoroughly clean the printer to remove the accumulation of paper residue, ink, and dust.
2. Pay special attention to cleaning the slide rails and pulley to ensure free or non-restrictive movement of the carriage assembly.

To clean the platen and other rubber parts, the platen cleaner must be used.

**CAUTION**

**Ensure that the platen cleaner does not come in contact with surfaces other than those rubber parts mentioned above. Platen cleaner may be harmful to certain finishes.**

Clean the platen and other rubber surfaces with a wiper saturated with platen cleaner.

**CAUTION**

**Do not drop platen when cleaning. Warpage may result and introduce erratic printout when reinstalled.**

**6.2.4.3 Lubrication** – Lubricate the inspected and cleaned printer in accordance with the following conditions:

1. Lubricate approximately every six months for printers in normal daily use.

**CAUTION**

**Do not lubricate too often. Too much lubricant can be worse than none at all.**

2. Lubricate a printer that has been sitting idle for an extended period (such as a branch loaner) before putting in use. Areas to be lubricated are: carriage system, carrier system, and platen. Lubricate the carriage system (Figure 6-1) as follows:
  - a. Carriage Rails (A) – Clean these items with alcohol wipers only.
  - b. Carriage Rail Bearings (B) – Spray with Molycote and manually oil on each side of carriage rails.
  - c. Carriage Pivots (C) – Apply one drop of polyoil to the pivot on each side of the carriage frame.
  - d. Carriage Pivot Spring Loops (D) – Lightly grease the end loops and posts on the pivot spring on each side of the carriage frame with lithium grease.
  - e. Ribbon Base Plate Pivots (E) – Saturate the felt washer on each end of the base plate pivot shaft with polyoil.

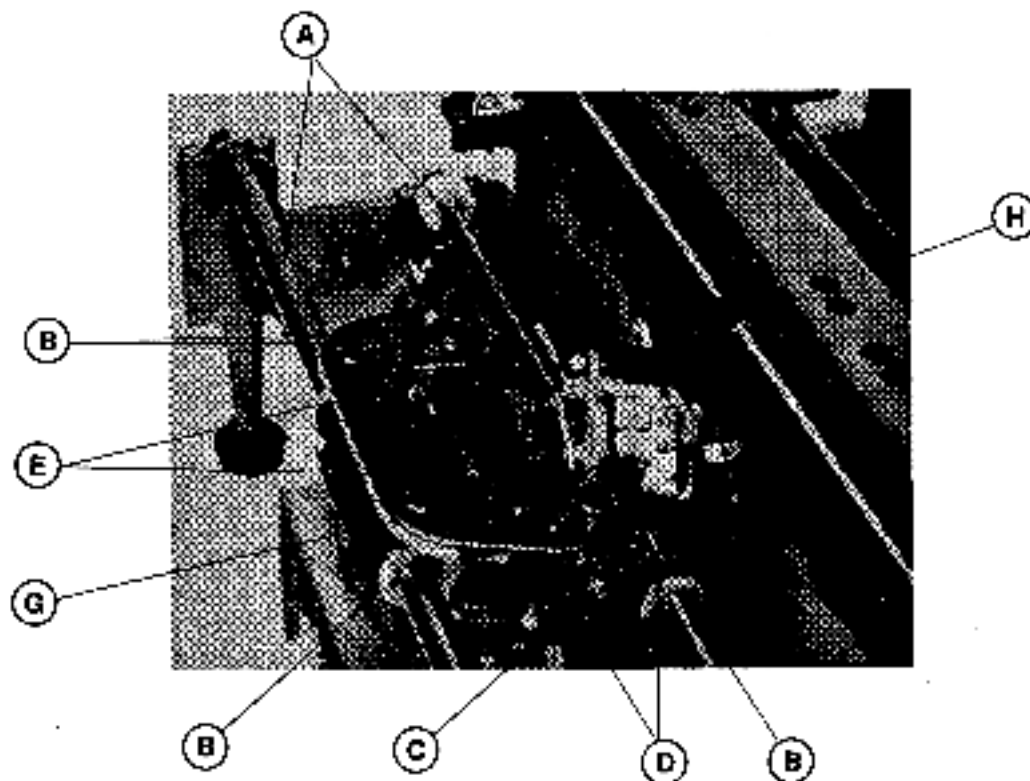

Figure 6-1 Carriage System Lubrication Points

M-0868

- f. Ribbon Drive System (F) – Apply one drop of polyoil to the drive and idler gear shafts and to the drive key slot.
- g. Hammer Armature Pivots (G) – Remove the rubber cup and fill the grease chamber with lithium grease. Replace rubber cup when finished.
- h. Print Hammer (H) – DO NOT lubricate this item. If customer uses cloth ribbon, ensure that hammer is clean.

Lubricate the carrier system (Figure 6-2) as follows:

1. Paper Feed Roller Shaft Pins (A) – Lightly grease the eight (8) pressure roller shaft pins with lithium grease.
2. Platen Position Lever Detent Plate (B) – Lightly grease the inside of this plate with lithium grease.
3. Platen Position Slide Plates (Carrier Frame) (C) – Lightly grease exposed slide surfaces (lever moved limit to limit) and all points of contact with pivots, eccentrics, guides, etc., with lithium grease.

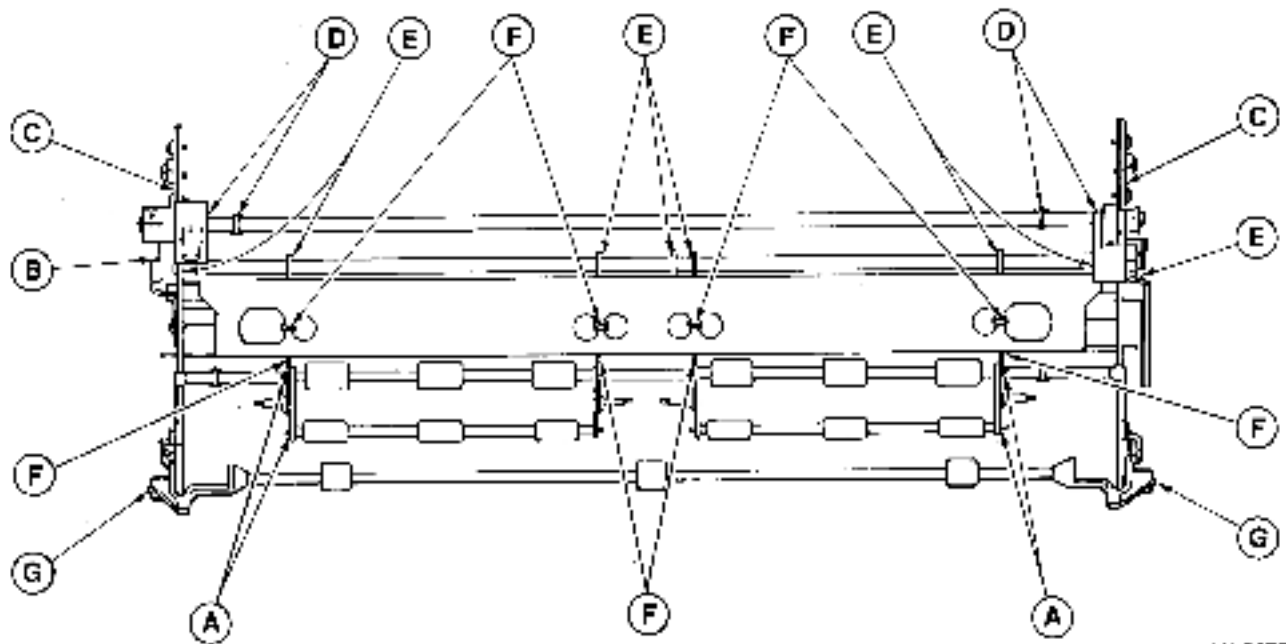

MI-047B

Figure 6-2 Carrier System Lubrication Points

4. Platen Position Torque Shaft Ends, Bearing Surfaces, and Spring Loops (D) - Lightly grease these points with lithium grease.
5. Paper Release Lever Tab Ramp and Shaft Pivots (E) - Lightly grease these points with lithium grease.
6. Paper Release Torque Shaft Pivots and Arm Slots (F) - Lightly grease these points with lithium grease.
7. Paper Bail Pivots (G) - Lightly grease these two points with lithium grease.

Lubricate the platen (Figure 6-3) as follows:

1. Paper Feed Idler Gear (A) - Inspect the large felt washer behind this gear. If it is becoming white in color, saturate with polyoil.
2. Platen Release Tab Arms (B) - Lightly grease the contact area between these arms and the carrier side frames.
3. Platen Hubs (C) - Apply one drop of polyoil to the bore of the hub at each end of the platen.

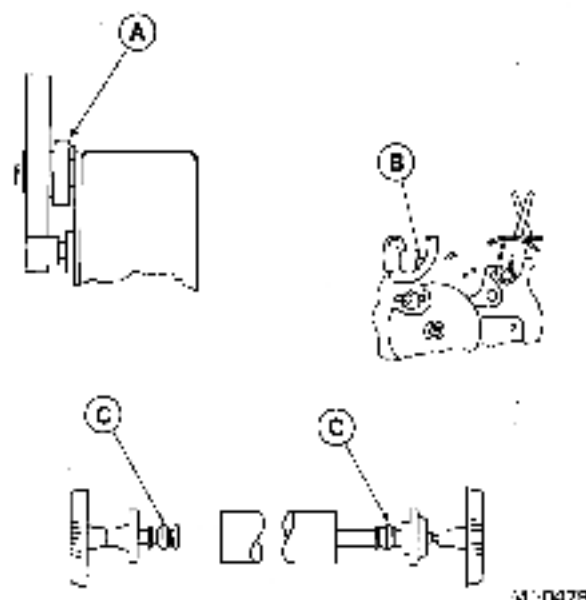

Figure 6-3 Platen Lubrication Points

### 6.3 DIAGNOSTIC FUNCTIONAL DESCRIPTION

#### 6.3.1 Overall Performance Test

Diagnostic test DHLQA is used to check the overall performance of both the controller and printer. This diagnostic has two main parts:

1. Internal logic tests - These tests are run with the LQP8-E printer placed off-line and serves to exercise the controller (M8366) circuits.
2. Dynamic printer tests - These tests are executed with the LQP8-E printer on-line and dynamically check all printer operational capabilities.

**6.3.1.1 Controller Diagnostic Test** - For this check, the printer must be placed off-line. Do this by removing the printer top front cover. The controller diagnostic test is now activated by following the steps in Paragraph 6.3.1.3.

Once initiated, the internal logic test loops 4096 times and, provided that there are no errors, the message END OF LOGIC TEST is displayed on completion of the test.

If an error occurs, the internal logic program displays "DHLQA FAILED." Also, the following program parameters are displayed: FC=XXXX, AC=XXXX, MQ=XXXX, FL=XXXX.

**6.3.1.2 Printer Dynamic Diagnostic Tests** - For these checks, the printer must be placed on-line. Do this by replacing the front cover on the printer. The printer dynamic diagnostic tests can now be activated by following the steps given in Paragraph 6.3.1.3.

**6.3.1.3 Diagnostic Load and Run Procedure** – To load and run printer diagnostic DHLQA, proceed as follows:

1. With system power ON, place diagnostic diskette in Drive 0 (left port).
2. Close drive door.
3. Press START switch then observe that the VT52 displays the following:  
0123
4. Type any key on keyboard, then wait for the VT52 to display the following:  
—
5. When running internal logic test, proceed to step 6. When running dynamic printer tests, proceed to step 8.
6. Using the keyboard, type any key and observe the following message:  
R DHLQA (or whatever version software installed)
7. Press the RETURN key on the keyboard. The diagnostic now begins automatically at address 0200<sub>i</sub> (internal logic test).
8. Type the following message on the VT52 display:  
GET SYS DHLQA . SV
9. Press the RETURN key.

**NOTE**

At this point, service personnel may wish to alter certain diagnostic program constants in order to run the tests on 21.59 cm (8-1/2 in) rather than 35.56 cm (14 in) paper. Altering of constants is covered in Paragraph 6.3.2.7.

10. Type the following message on the VT52 display:  
START 0203
11. Press the RETURN key; then, while holding the CTRL key down, type the letter G.
12. Check that VT52 displays the following:  
SR=
13. Type the number of the desired dynamic printer test [0045–0057 (e.g., swirl pattern is 51<sub>o</sub>)].
14. Press the RETURN key. The selected diagnostic test is now executed on the printer.

**6.3.1.4 Manual Entry of Characters for Printing** – Printing of operator-selected characters is accomplished using dynamic diagnostic test 56<sub>8</sub>. To print a line of desired characters, proceed as follows:

1. Select diagnostic test 56<sub>8</sub> using the steps in Paragraph 6.3.2.3.
2. Enter a line of desired character via the keyboard. Each character is displayed on the VT52 display as it is typed.
3. When the desired line of characters is entered and displayed, press the RETURN key. The displayed character string is now echoed on the printer.

**6.3.1.5 Halting an In-Process Dynamic Diagnostic Test** – To stop an in-process printer diagnostic test, simultaneously press the CTRL and T keys on the keyboard.

**6.3.1.6 Restarting Dynamic Diagnostic After Halt** – To initiate another diagnostic following a halt, proceed as follows:

1. While holding the CTRL key down, type the letter G.
2. Enter the number of the desired diagnostic test.
3. Press the RETURN key; the newly selected diagnostic test is now executed.

**6.3.1.7 Procedure for Modifying the Contents of a Location** – To modify a location [e.g., as for 21.59 cm (8-1/2 in) rather than 35.56 cm (14 in) wide paper] proceed as follows:

1. Simultaneously press the CTRL and C keys.
2. Check that VT52 displays the following:  

---
3. Type the following message on the VT52:  
OD
4. Press the RETURN key; then check that the VT52 display executes two line feed commands.
5. Type the octal notation of the address to be altered; then press the / (slash) key.
6. Check that the location address and its contents are displayed on the VT52. For example, if a line length constant of 0204<sub>8</sub> is stored in location 0134<sub>8</sub>, then the message displayed on the VT52 is:  
  
0134/0204
7. Enter the new parameters in the selected location by typing the desired values on the keyboard. [For example, location 0134 is changed from 0204<sub>8</sub> to 0110<sub>8</sub> to run the diagnostic on 21.59 (8-1/2 in) paper. Similarly, location 1534<sub>8</sub> is changed from 3044<sub>8</sub> to 1700<sub>8</sub> to run test 47<sub>8</sub> on 21.59 (8-1/2 in) paper].
8. Press the RETURN key. The new parameters are now entered in the selected location.
9. See step 10 in Paragraph 6.3.1.3 for restart procedure.

## 6.4 FUNCTIONAL SECTION FAULT ISOLATION

### 6.4.1 Specific Tests and Descriptions

When reported failures indicate erratic printer behavior or degraded print quality, a total performance check can be achieved quickly through use of selective diagnostic tests for specific operations or characters. These tests completely exercise the printer. A breakdown of the diagnostics and the operational capabilities they test are as follows:

1. Test 45 - Horizontal spacing. This test checks that the carriage is being positioned by the programmed amount before printing each dot.
2. Test 46 - Vertical spacing. This tests checks that the paper is advanced by the programmed amount prior to printing a 5.08 cm (2 in) line of underscores.
3. Test 47 - Carriage positioning. This test checks that the carriage is being positioned correctly.
4. Test 50 - One line/character. This test checks the print velocity of the printer.
5. Test 51 - Swirl pattern. This test checks the printing of all characters on the print wheel. Printing of a dozen lines is sufficient to determine the quality of print. Line feed problems can also be detected during this check by observing the relationship between acute accent and underscore characters.
6. Test 52 - Ribbon lift/drop with overprint. This test checks the ribbon lift capabilities of the printer.
7. Test 54 - Nonprinting character codes. This test checks that none of the ASCII control characters can cause an erroneous character printout. For all control characters, the lower case w is printed.
8. Test 56 - Operator generated print line. This test allows the operator to enter a line of characters on the display for subsequent printout on the LQP8. To further evaluate print quality, use this test as follows:
  - a. Enter and then print a line of capital Zs. The observed printout can then be used to check platen height settings.
  - b. Enter and then print a line of capital Hs. The observed printout can then be used to check print wheel to hammer alignment.

### 6.4.2 Fault Isolation

Table 6-2 summarizes catastrophic failure modes and remedial actions for the LQP8-E printer. Table 6-3 summarizes degraded printout failure modes and related corrective actions.

## 6.5 TROUBLESHOOTING

### 6.5.1 Initial Analysis

In general, printer malfunctions can be considered as falling into one of two broad categories:

1. Printer fails to print - Such catastrophic faults usually stem from electrical or electronic malfunctions such as no ac power, a bad power supply, or defective PCBs.
2. Printed data is erroneous or degraded - Failures falling in this category generally are caused by misalignment of one or more of the numerous LQP8-E mechanical adjustments.

Table 6-2 Catastrophic Failure Troubleshooting Chart

Symptom	Probable Cause	Action	Reference	
Printer does not power up and no indicator lamps light	Low ac line voltage/current	Check line power		
	Defective power cord or not plugged in	Plug in or replace		
	Blown power supply fuse(s)	Replace fuse(s)		
	Power supply defective	Replace power supply		
	Faulty controller PCB	Swap out controller PCB		
PRINTER READY lamp lights but printer exhibits no carriage and/or print wheel movement	Faulty controller PCB	Swap out controller PCB		
Printer goes into and remains in CHECK	Defective interface cable or not properly seated in connectors	Check connections and repair or replace interface cable as required		
	Low voltage output from power supply	Adjust power output		
Carriage overshoots on long slews	Low voltage output from power supply	Adjust power output		Diablo Power Supply Manual
Power supply output normal but no carriage movement	Carriage amplifier PCBs defective	Repair or replace PCBs		Diablo Power Supply Manual
Power supply output normal but no print wheel movement	Print wheel PCBs defective	Repair or replace PCBs		

Occasional and inconsistent problems such as the printer going into check or a broken mylar ribbon are special cases, that is, they do not fall in either of the above categories. In most instances, however, the field service representative can begin the analysis by placing the observed fault in either of the previously mentioned two categories.

Printers receiving normal power and yet falling in the fails-to-print category may have a faulty controller PCB or the interface cabling may be disconnected/defective. A swap out of controller PCBs in the PDP-8, coupled with a check of interface wiring connections, may correct such malfunctions. The internal logic test portion of the printer diagnostic test should be run to evaluate controller PCB operation prior to swap out. If the printer still fails to print following replacement of the controller PCB, then the printer PCBs should be swapped out, beginning with the logic 2 PCB.

If the printer exhibits some movement (e.g., carriage and print wheel motion) but still does not print, the fault most likely lies in the printer PCB (Figure 6-4). If the printer still fails to print, following a swap out of the print wheel amplifier PCB, it could mean that the hammer armature coil is open/burned out and must be replaced. In such case, the entire carriage assembly must be replaced.

Figure 6-4 indicates the main role(s) played by each of the printer PCBs and as such is useful in determining which PCB should be swapped out for any given malfunction. For example, if there is print wheel and hammer movement, but no carriage motion, then the carriage amplifier and servo PCBs should be swapped out. (Refer to Figure 6-16 for further PCB reference locations.)

Troubleshooting information at the end of this chapter breaks down all failure types in greater detail. Symptoms and remedial actions are listed for all malfunctions in the fails-to-print category. For malfunctions in the degraded print category, sample printout errata (related to the dynamic diagnostic tests) are shown. The related adjustment procedure for correcting the degraded print quality is also referenced.

### 6.5.2 Alignment and Adjustment

The subsequent paragraphs describe the alignment procedures to be carried out on the LQP8-E printer. The majority of these adjustments require use of the special alignment tool included in the spares kit. Figure 6-5 shows an outline of the tool and indicates the intended use of its various mechanical features.

The following conditions are set forth as prerequisites for carrying out alignment procedures involving the special tool.

1. Power - Power is to be applied when making these adjustments. Power is necessary to electrically detent the print wheel and carriage servo motors. It is also necessary for cycling the printer through a Restore sequence when required.
2. Platen - A defect free platen is to be installed for all platen adjustments.
3. Ribbon - Ribbon adjustments are to be made with a mylar ribbon installed.
4. Platen position (manifold) lever - This control is to be positioned fully forward for all adjustments.

#### CAUTION

To prevent damage to the printer, always remove the alignment tool from the print wheel motor shaft before initiating a Restore sequence.

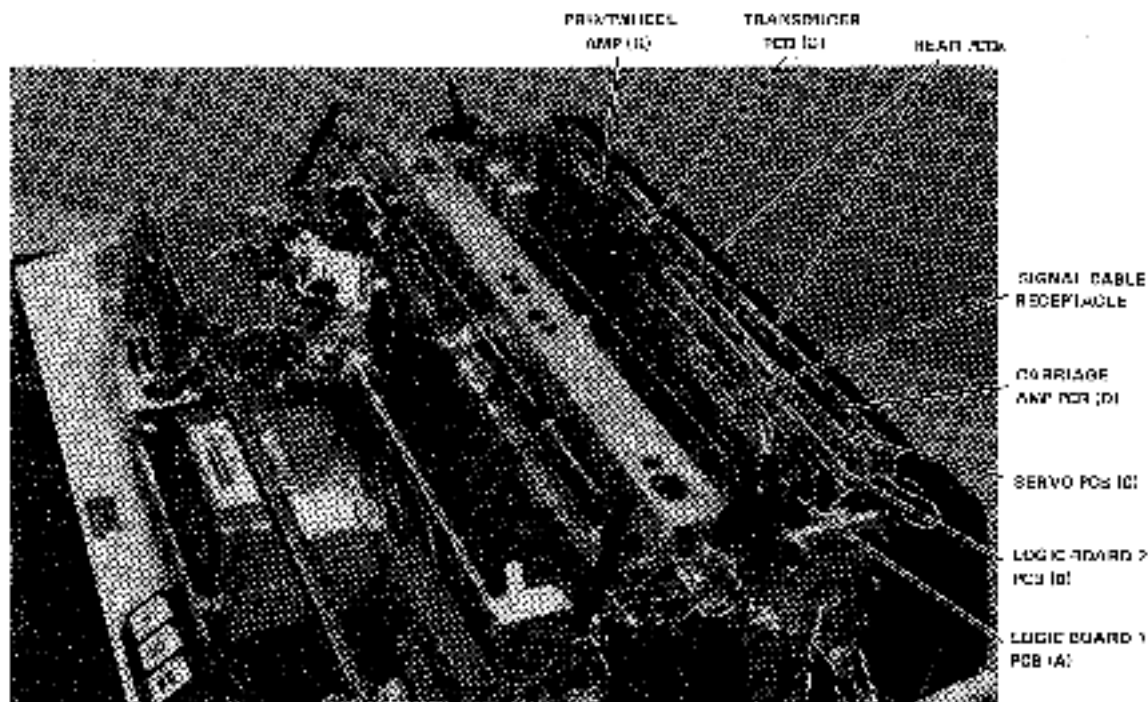

6044-1K

#### Print Wheel Amplifier PCB (II)

- Print wheel power transistors
- Ribbon feed circuit
- Hammer energy/Drive circuit

#### Transducer PCB (G)

- Generates transducer signals
- Generates carriage position and print wheel position signals

#### Carriage Amplifier (PCB) (D)

- Power monitor circuit
- Paper feed circuit
- Carriage power transistors

#### Servo PCB (C)

- D/A Converter
- Main summing circuit. Generates servo error signal for print wheel and carriage
- Generate C and D pulses
- Feedback circuit for print wheel and carriage
- Processes hammer energy commands

#### Logic 2 PCB (B)

- System sublock (B,C)
- Program memory, program counters, comparators, scratch pad, table ROM, instruction decode, operating registers A and B, adders, storage register

#### Logic 1 PCB (A)

- Interface
- Processes input commands and data
- Generates ready and status signals

Figure 6-4 Printed Circuit Board Layout and Function Description

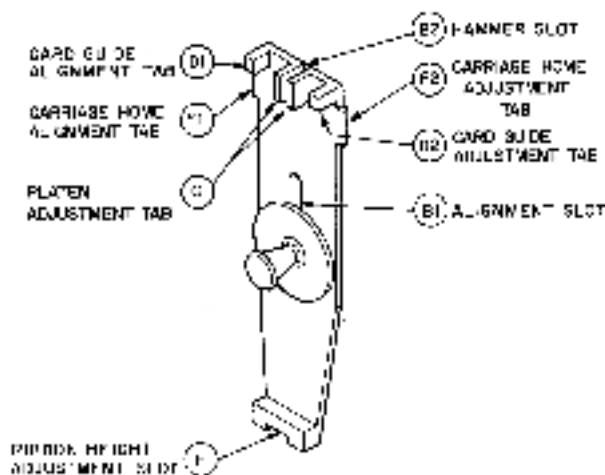

08-1740

Figure 6-5 Multipurpose Alignment Tool

**6.5.2.1 Print Wheel to Hammer Adjustment** - To align the print wheel with the hammer, proceed as follows:

1. Apply power to the printer, and verify completion of Restore sequence.
2. Remove any paper from the carrier, remove the ribbon cartridge, and remove the print wheel.
3. Install the tool firmly on the print wheel motor shaft, and ensure that it is properly seated with its alignment slot B1 centered over the print wheel alignment tab. Rotate the print wheel motor and tool to bring the tool's hammer slot B2 to the top in front of the print hammer.
4. Block the carriage home sensor (insert a piece of dark paper in its slot) to detent the print wheel motor.
5. Manually push the hammer forward lightly, until its face enters hammer slot B2 on the tool (Figure 6-6). If the hammer slides easily into the tool slot without contacting the sides of the slot, print wheel to hammer alignment is correct. Therefore, no adjustment is necessary. If the hammer face contacts the tool surface, continue with this procedure.

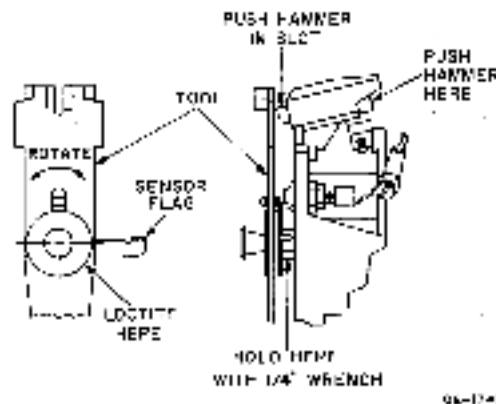

Figure 6-6 Print Wheel-to-Hammer Alignment Positions

6. Place a 1/4 inch open wrench on the nut of the print wheel motor shaft and hold to prevent the shaft from turning. Move the tool, as necessary, to achieve proper alignment with the hammer.

#### CAUTION

In this step, the tool is moving the print wheel locator tab/sensor flag on the motor shaft. This part has been bonded to the shaft with Loctite. If it is necessary to flex this part to break the Loctite bond, exercise care not to deform the part. Re-bond with Loctite when alignment has been completed. Care is essential in this step since movement of the home sensor flag (relative to the home sensor transducer) may necessitate carrying out the adjustment procedure in Paragraph 6.5.2.9.

7. Repeat step 5 to verify proper print wheel to hammer alignment; then, remove carriage home sensor block.

**6.5.2.2 Platen to Print Wheel Alignment Procedure** - This adjustment affects both platen height position and card guide position. Therefore, both of these adjustment procedures must be carried out after aligning the platen to the print wheel. Proceed as follows:

1. Apply power and loosen the card guide mounting screws and lower the guide as far as it will go.

#### WARNING

If the alignment tool is installed prior to applying power, the print wheel motor shaft will attempt to spin to the HOME position with the tool attached. The resultant action could cause both personal injury and major damage to the carriage area of the printer.

2. Tilt the print wheel motor forward and verify that the alignment tool (mounted on the print wheel shaft) clears the card guide completely (Figure 6-7). Tilt it back again.

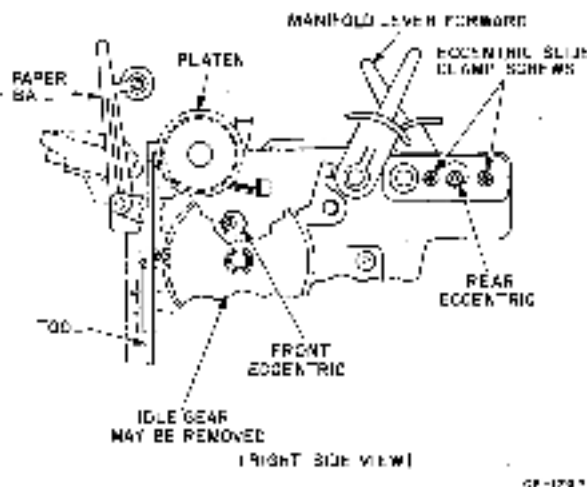

Figure 6-7 Platen-to-Print Wheel Adjustment

3. Place the carriage servo switch (located near top edge of the carriage power amplifier, PCB, slot D) in the OFF position.
4. Using a 1/4 inch open end wrench, loosen the locknut on the front eccentric, position the front eccentric on each end of the carrier assembly, and set each to its midrange (lobe facing away from you).
5. Move the carriage as far left as it will go. Tilt the print wheel motor forward and verify the following relationship between the platen and the tool:
  - a. The minimum platen setting is when the tool's platen adjustment tabs (C) lightly touch the platen surface with a barely perceptible drag.
  - b. The maximum platen setting is when clearance of no more than 0.0076 cm (0.003 in) can be measured between the tabs (C) and the platen surface.
6. Tilt the print wheel motor back and move the carriage as far as it will go; then, tilt the print wheel motor forward again and check the platen-to-tool relationship. If the platen adjustment is within the limits stated above, and is equal for both ends of the platen, then no adjustment is necessary. If the print wheel to platen setting is out of tolerance, continue with the following steps.
7. Loosen the two rear eccentric slide clamp screws and the screw for the rear eccentric itself.
8. Adjust the rear eccentric, using a 7/16 inch open end wrench, to bring the platen clearance to within the limits specified; then, tighten the slide clamp screws.

9. Move the carriage to the opposite end of the platen and check for proper clearance.
10. Repeat steps 8 and 9 until the clearance on each end of the platen are within specified limits and are equal.
11. Tighten rear eccentric clamp screws when adjustment has been completed.

**6.5.2.3 Card Guide Height and Position Adjustment** - When this procedure is carried out immediately after the platen to print wheel adjustment, it can be assumed that the two card guide mounting screws have already been loosened and the card guide lowered. If the card guide has not been lowered, loosen the two mounting screws and lower the guide as far as it will go. Also, ensure that the alignment tool is positioned firmly on the motor shaft. To adjust the card guide position, proceed as follows:

1. Push the print hammer into the hammer slot (B2) on the tool, and hold it there (Figure 6-8).

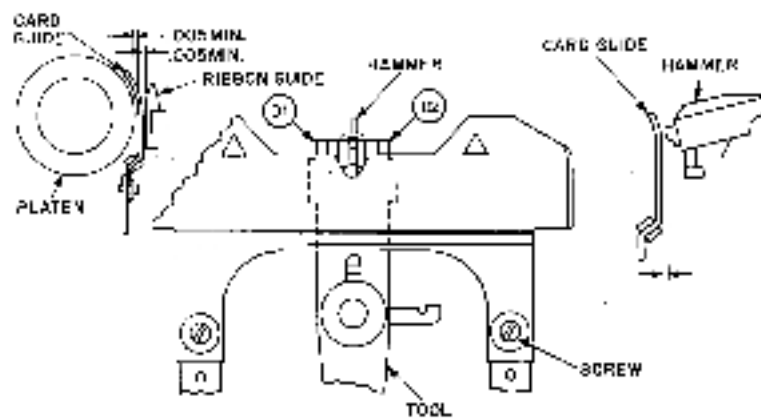

Figure 6-8 Card Guide Height Adjustment

2. Raise the card guide gently, until its top edge contacts the undersides of card guide alignment tabs, D1 and D2, with equal pressure.
3. Release the hammer and, while holding the card guide in contact with the tool, tighten the card guide's two mounting screws.
4. Using a 0.0127 cm (0.005 in) plastic shim, check for no-drag shim clearance between the card guide and the ribbon guide posts on both sides of the carriage. Normally, this dimension is set by the depth of the ribbon guide post tabs. Shim drag indicates the card guide has become tilted, in which case its support arms should be gently reformed to achieve proper clearance around the ribbon guide posts.
5. Using the 0.0127 cm (0.005 in) plastic shim, check for no-drag clearance between the card guide and the platen along the full length of the platen.

**6.5.2.4 Ribbon Height Adjustment** - To adjust the ribbon height (Figure 6-9) proceed as follows:

1. Manually position the carriage assembly to the left of the carriage drive motor.
2. Using a Torx driver, loosen (do not remove) the front slide rail hold down screws; then, move the slide rail to the left to disengage it from the carriage assembly.
3. Using long nose pliers, remove the two retainer clamps from beneath the front slide rail bearing assembly (Figure 6-9).
4. Remove the slide rail bearing assembly to gain access to the ribbon lift coil mounting screws (Figure 6-10).
5. Place a 5/32 inch box and wrench on one of the two lock nuts (Figure 6-10), then use a 3/16 inch nut driver to loosen the screw a couple of turns. Repeat loosening procedure for the second bolt.
6. Using a 3/16 inch wrench, loosen ribbon lift eccentric locking screw (Figure 6-9).
7. Remove print wheel and install alignment tool firmly on print wheel shaft.
8. Install a mylar multistrike ribbon; then, rotate tool so that wide gap (E) at base of tool is positioned opposite print wheel hammer.
9. Manually push up on ribbon lift grommet (Figure 6-9) so that grommet contacts ribbon lift eccentric.
10. Using a slotted head screwdriver, rotate eccentric so that a mylar ribbon appears in notch (E) on alignment tool; then tighten the ribbon lift eccentric locking screw.

**NOTE**

**Lobe of eccentric must be facing front of machine.**

11. Insert a 0.02032 cm (0.008 in) plastic shim between ribbon lift coil and pole plate.
12. With ribbon lift grommet clamped against eccentric, energize ribbon lift coil (see Diagnostics).
13. Place a 0.02032 cm (0.008 in) plastic shim between ribbon lift coils and pole plate (Figure 6-10).
14. Place 5/32 inch wrench over one of the two lock nuts.
15. While holding rear of ribbon lift plate down [with 0.02032 cm (0.008 in) plastic shim in place], use a 3/16 inch nut driver to exert upward pressure on ribbon lift coil mounting bolt; then tighten the bolt. Repeat steps 14 and 15 for remaining ribbon lift mounting bolt. The clearance between top of ribbon lift coils and ribbon base plate should now be exactly 0.02032 cm (0.008 in).
16. De-energize ribbon lift coil by pressing the RETURN key on the keyboard.

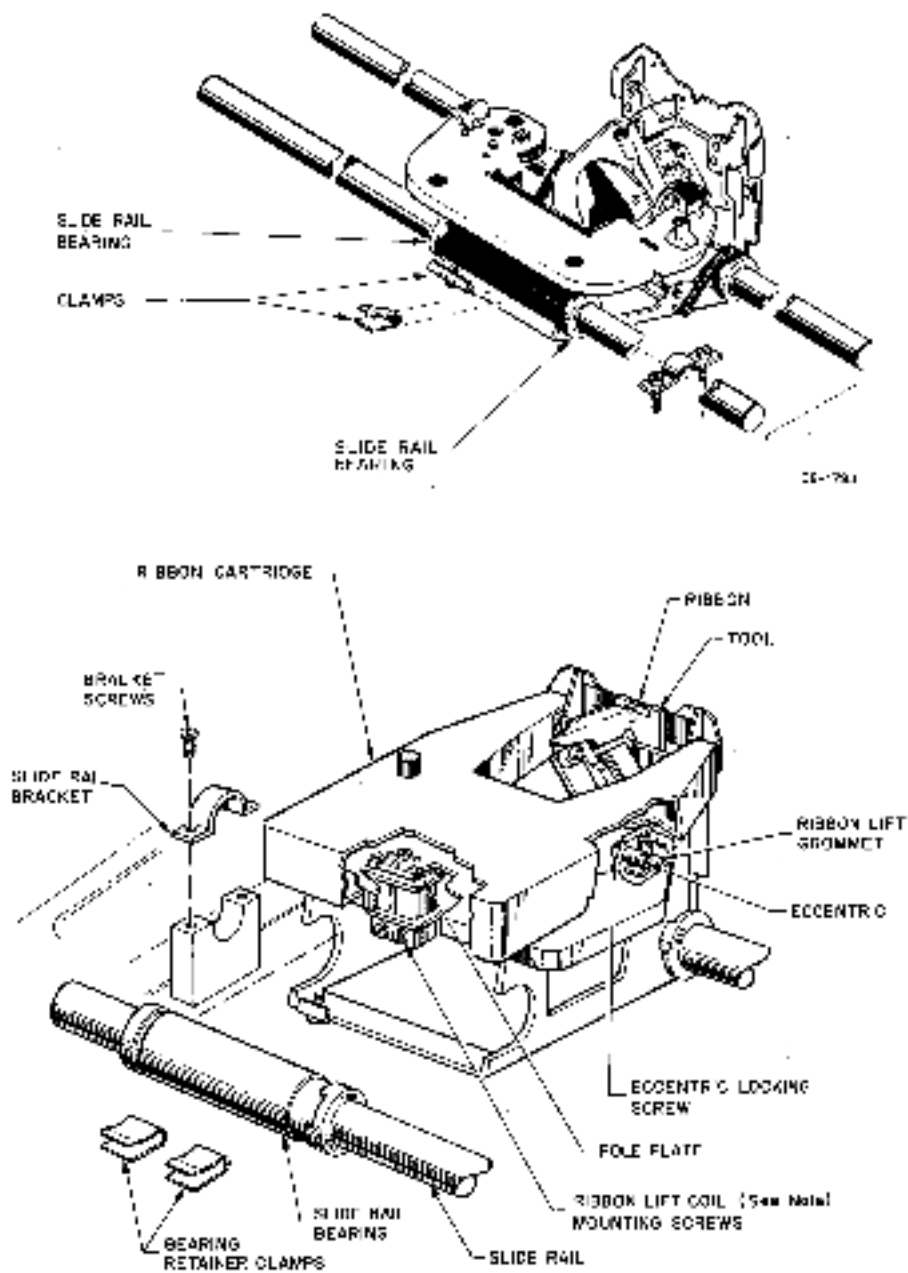

06-794

06-1734

Figure 6-9 Ribbon Height Adjustment

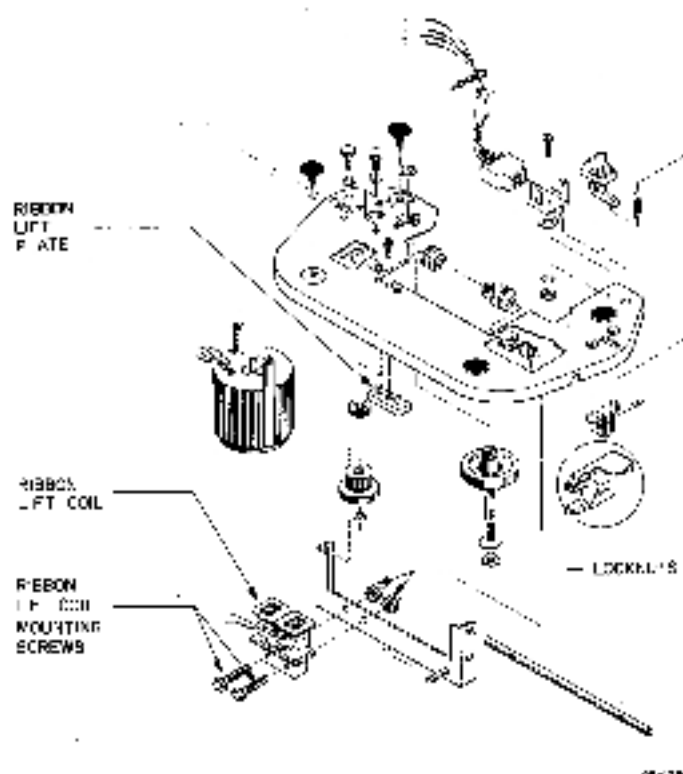

Figure 6-10 Exploded View of Ribbon Lift Assembly

17. While holding the ribbon lift grommet against ribbon lift eccentric, measure the gap between ribbon lift coils and pole plate. The gap should measure between 0.0076 and 0.02032 cm (0.003 and 0.008 in). Also, top of mylar ribbon should be visible in notch (E) on alignment tool. If not, repeat procedure in steps 10 through 16.
18. On successful completion of procedure, remove alignment tool and replace slide rail bearing assembly and slide rail by reversing procedure in steps 1 through 4.

**6.5.2.5 Carriage Home Adjustment** - To adjust the position of the carriage home sensor flag (Figure 6-11), proceed as follows:

1. With power applied to the printer, initiate a Restore sequence.
2. Insert alignment tool between printer mainframe casting and the carriage frame (Figure 6-11).
3. Using a feeler gauge, measure the distance between tool tabs F1/F2 and mainframe casting. Check for a maximum cumulative distance between tool tabs and mainframe casting of not more than 0.02032 cm (0.008 in).
4. If gap exceeds 0.02032 cm (0.008 in), loosen eccentric locking screw, then adjust eccentric for proper gap.
5. Tighten eccentric locking screw following adjustment.

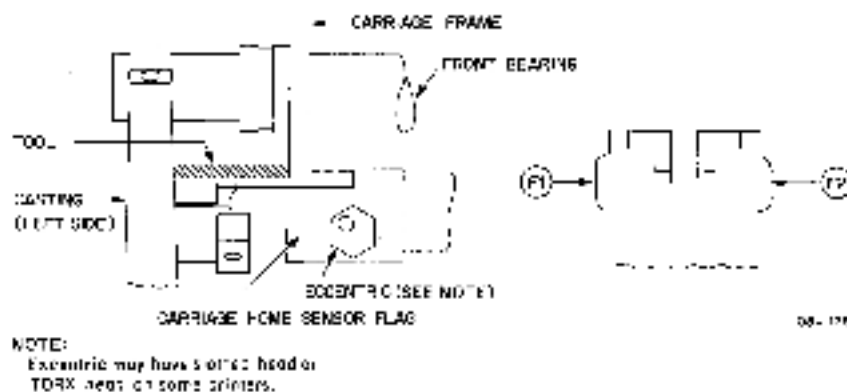

Figure 6-11 Carriage Home Adjustment

**6.5.2.6 Hammer Armature Gap Adjustments** – To adjust the hammer armature gap (Figure 6-12), proceed as follows:

1. Remove ribbon cartridge and swing platen adjust lever fully forward.
2. Install a print wheel and then align one of the print wheel character petals with the print hammer.
3. Hold the hammer armature (Item A on Figure 6-12) against the hammer coils (F).
4. Push the print hammer (C) in as far as it will go to lightly rest the print wheel character petal (D) against the platen (P).
5. Measure the gap between the print hammer (C) and the hammer armature (A). This gap must be between 0.18542 cm (0.073 in) and 0.21082 cm (0.083 in). If not, loosen armature assembly mounting screws (G) and position hammer armature for the above gap. After adjustment, tighten mounting screws (G).
6. Measure gap between hammer armature (A) and the armature stop eccentric (B). This gap must be between 0.11938 cm (0.047 in) and 0.12192 cm (0.048 in). Adjust the eccentric to achieve this gap setting.

**6.5.2.7 Platen Height Adjustment** – Platen height adjustment is achieved by rotating the eccentrics (Item A, Figure 6-13) at each end of the printer. Prior to adjusting platen height, print a line of capital Zs by using diagnostic test 56. Examine the printed Zs (see samples shown in Table 6-3) to determine which side of the platen is too low/high. Next, remove the platen and adjust the eccentrics for best print quality. After adjustment, the platen can be replaced and a new line of Zs printed to see if further adjustment is required.

**6.5.2.9 Print Wheel Home Sensor (Transducer) Alignment** – This alignment procedure is not routinely performed in the field. It is to be carried out only under special conditions such as the following:

1. Random print errors continue to occur following substitution of the carriage assembly.
2. The transducer needs alignment following the print wheel to hammer adjustment (Paragraph 6.5.2.1).

Alignment of the print wheel home sensor is a three step procedure – print wheel to hammer alignment, transducer gap adjustment, and print wheel even timing signal alignment. The second of these steps adjusts the amplitude of the transducer output spike, while the third adjusts the relationship of the print wheel even clock to the leading edge of the transducer square wave. An oscilloscope is required for this procedure.

To align the print wheel to the hammer, apply power and follow the procedure given in Paragraph 6.5.2.1. Rotate the print wheel on the shaft, if necessary, to achieve alignment. Replace the special tool on the print wheel shaft with a print wheel then continue the procedure by performing the following steps:

1. Remove printer covers.
2. Remove power from the printer by pressing the system POWER on/off switch or by disconnecting ac power cord leading to printer power supply.
3. Remove transducer PCB and place on extender board; then re-insert extender board in transducer slot.

#### CAUTION

Never remove PCBs when power is applied as damage may result. Further, never apply power with a PCB removed since this could also prove harmful to the printer.

4. Place oscilloscope probe on resistor D20 on the transducer PCB.
5. Re-apply power to the printer.
6. Initiate a Restore operation by pressing the cover interlock switch. (If a diagnostic routine that loops on the Restore sequence is available, use it rather than manually pressing the interlock switch.)
7. Observe the oscilloscope for a 600 mV negative going spike each time the interlock switch is pressed.
8. If the observed spike is less than 600 mV, use a 5/16 inch wrench to loosen the rear nut (Figure 6-15) on the print wheel transducer; then, manually screw the transducer in or out to achieve the 600 mV condition.
9. Lock in position by tightening rear nut.

#### CAUTION

Be careful not to use too much force since damage to transducer plastic housing may result. Also, ensure that print wheel sensor arm does not hit transducer (Figure 6-15).

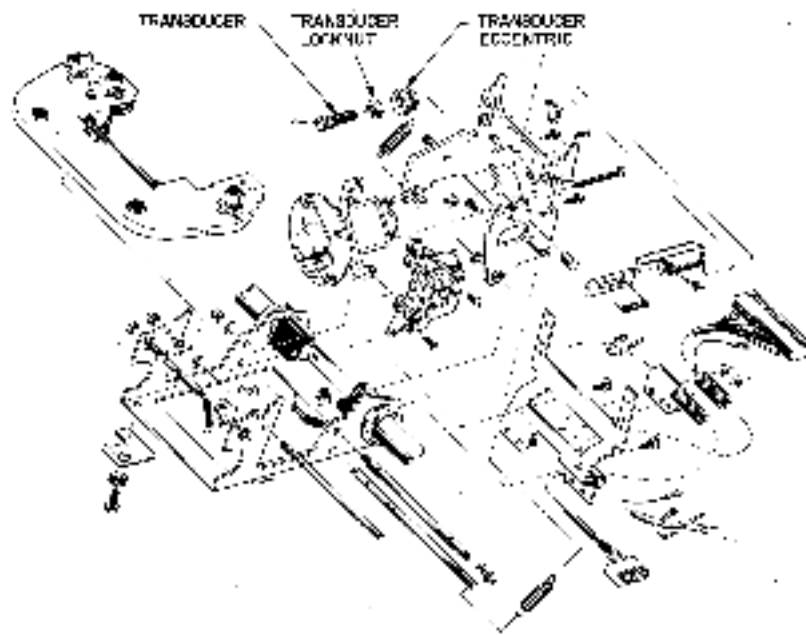

100-1700

Figure 6-15 Exploded View of Carriage Assembly

10. Remove power from the printer as in step 2.
11. Remove extender board and disconnect transducer PCB; then, re-insert transducer PCB in slot G.
12. Remove logic board 1, PCB and place on extender board; then, insert extender board in slot A.
13. Reapply power to the printer.
14. Connect one of the oscilloscope probes between the channel 1 external trigger input (e.g., CH 1 EXT TRIG INPUT if a Tektronix model 453 oscilloscope is being used) and print wheel home check point (chip E25, pin 14 of logic board 1).
15. Place oscilloscope channel 2 probe on print wheel even check point (chip E25, pin 6 of logic board 1).
16. Set the oscilloscope controls for the following conditions:
  - a. External source (e.g., SOURCE switch to EXT on model 453).
  - b. Trigger on negative (e.g., SLOPE to - on model 453).
  - c. 50  $\mu$ s per screen division (e.g., TIME/DIV switch to 50 on model 453).
17. Observe the oscilloscope screen; then, initiate a Restore sequence by pressing the cover interlock switch. Check for a negative going transition in the displayed trace.
18. Vary the channel 2 position control (e.g., POSITION on model 453) until the negative transition produced on each Restore sequence appears in the center of the screen.
19. Set the oscilloscope controls for 20  $\mu$ s per screen division.
20. Place a 7/16 wrench on the transducer eccentric (Figure 6-15); then rotate eccentric so that negative transition occurs 160  $\mu$ s after the start of the trace (negative transition coincides with eighth division marker on the screen).

#### NOTE

Movement of the transducer eccentric will probably affect the voltage level achieved in steps 2 through 9. Therefore, the entire procedure must be repeated until the spike observed in step 8 is 600 mV and the trace observed in step 20 equals 160  $\mu$ s.

21. Initiate a series of Restore sequences; ensure that the print wheel stops over letter E after each restore.

### 6.5.3 Removal and Replacement

The subsequent paragraphs present a step by step procedure for removing and replacing the carriage assembly. Figures 6-16 through 6-29 are provided as an aid in identifying parts during the removal and replacement process.

**6.5.3.1 Carriage Removal Procedure** - To remove the carriage assembly, proceed as follows:

**CAUTION**

Caution must be exercised during the carriage removal/replacement procedure to ensure that the carriage pulley is not unstrung and that the carriage pulley is not allowed to spin (flip). If the cable is unstrung, the printer will have to be returned to the manufacturer for service and repair.

1. Remove cover, PCB hold-down bracket, and signal cable from the printer.
2. Remove the two rear logic boards containing heat sinks (Figures 6-16 and 6-17).
3. Remove signal cable from logic board 1 (Figure 6-16).
4. Tilt assembly as shown in Figure 6-17 and remove the four screws securing rubber feet.
5. Remove bottom panel with cord (Figure 6-18).
6. Remove three cable connectors, as many Fastons as necessary, and tie wraps (Figure 6-19).
7. Remove bottom plate by disconnecting four screws (Figure 6-20).
8. Remove ground wire screw under paper chute (Figure 6-21).
9. Cut tie wraps attaching wires to bottom plate (Figure 6-21).
10. Pop carriage cable out of clips to free it from bottom plate (Figure 6-21).

**NOTE**

For reinstallation, twist the carriage cable connector two turns counterclockwise before installation. This prevents the cable from dragging and possible damage.

11. Remove four screws, two clamps with two screws each (Figures 6-19 and 6-21), to free wires from bottom plate. Note and mark the position of the clamps before they are removed. Installation of these clamps is critical for proper mechanical clearance.
12. Push all wires through top and out of way so they do not interfere with subsequent steps.
13. Move carriage assembly to right side of carriage drive motor; that is, to position shown in Figure 6-22.
14. Place Torx driver on carriage pulley hold-down screw (Figure 6-22 and 6-23).
15. Loosen but do not remove the cable tension screws (Figure 6-21). It is recommended that no more than two or three turns be made when loosening these screws.
16. Remove hold-down screw from carriage pulley. Catch the washer between carriage assembly and the pulley (protruding side sets under pulley).

17. Slide carriage to the left gently so the pulley does not disengage from cable wire (Figure 6-24) and that there is no evidence of drag.

**NOTE**

**If pulley disengages cable wire, it is difficult to restring and the unit may have to be returned to the manufacturer for service and repair.**

18. Loosen, but do not remove, eight rail hold-down screws to loosen four rail clamps (Figure 6-25).
19. Move the two rubber bumpers toward the middle of the slide rail (approximately 6 inches to the right as viewed in Figure 6-25).
20. Slide bottom rail to the left to disengage it from carriage assembly (Figures 6-26 and 6-27). Remove rubber bushing.
21. Hold carriage steady (Figure 6-28) and slide top rail to left.
22. Disengage top rail from carriage assembly, then remove carriage assembly from printer (Figure 6-29).

**NOTE**

**After installing rails, retighten cable tension screws loosened in step 15.**

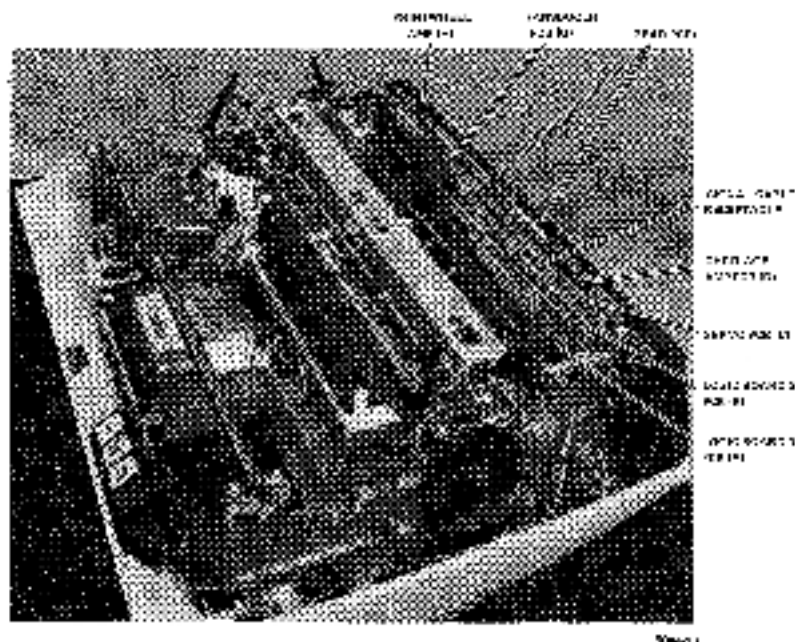

Figure 6-16 Printer Showing Cover and Signal Cable Removed

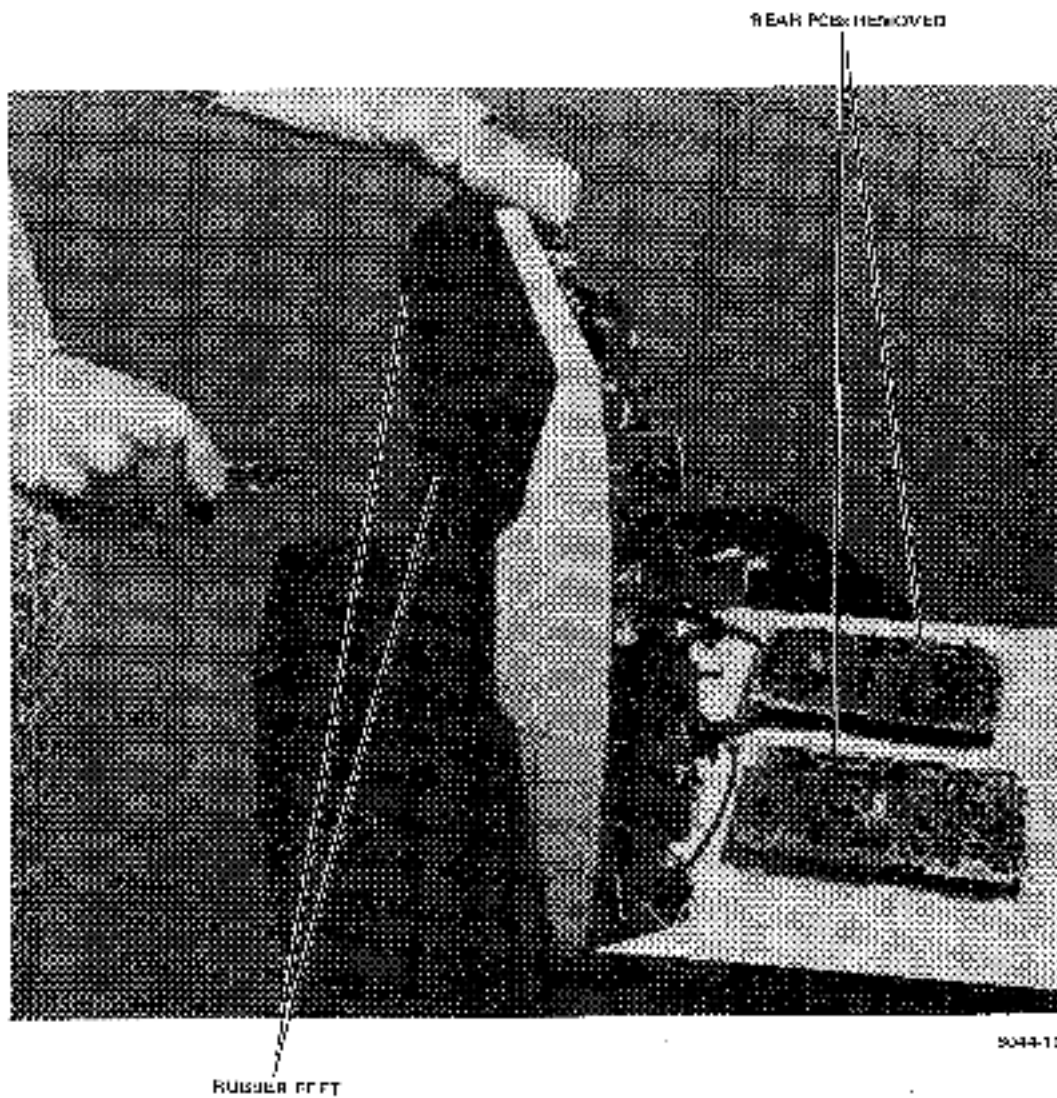
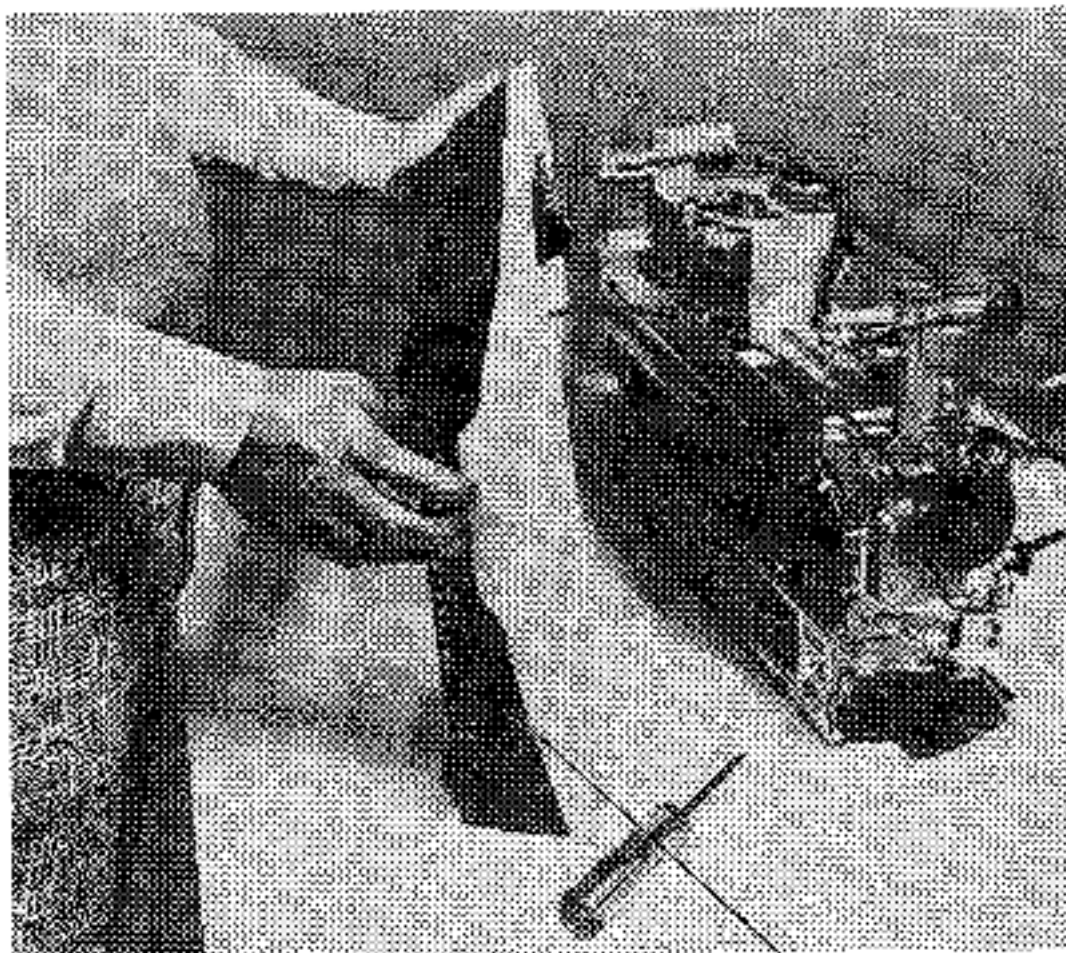

Figure 6-17 Printer Tilted on Back



BOTTOM PANEL REMOVED

AD54 17

Figure 6-18 Printer Showing Bottom Panel Removed

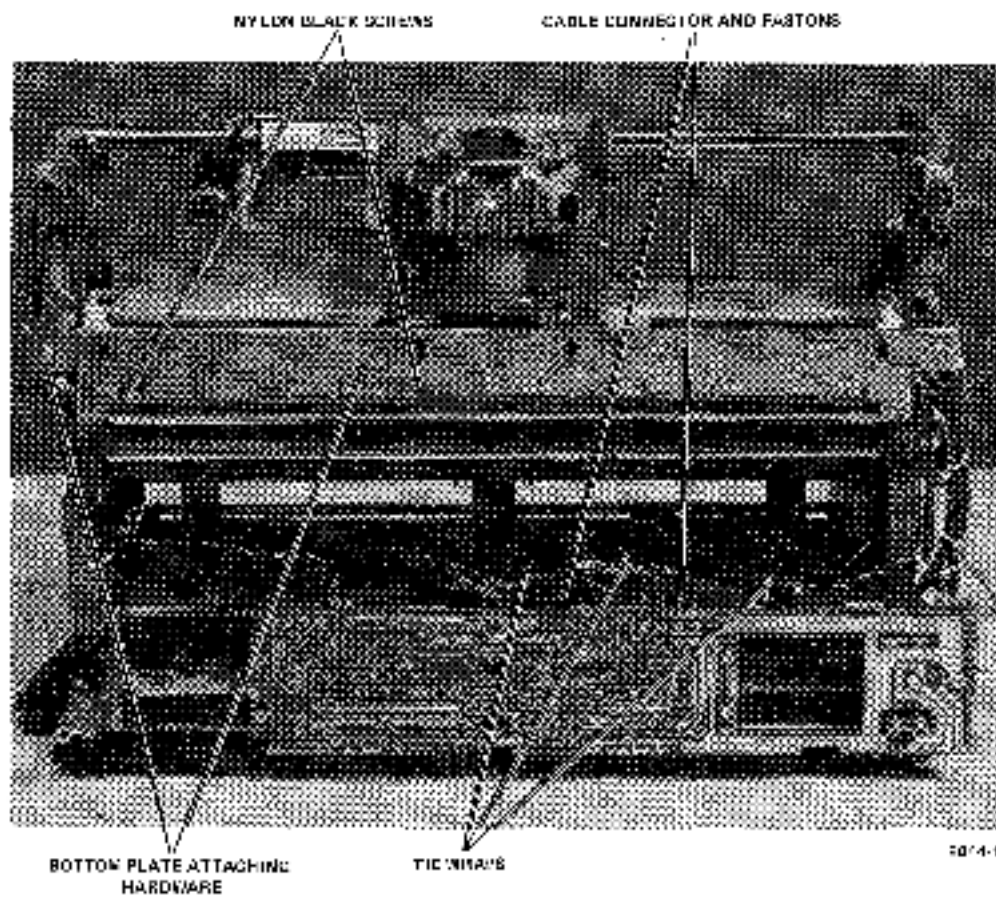
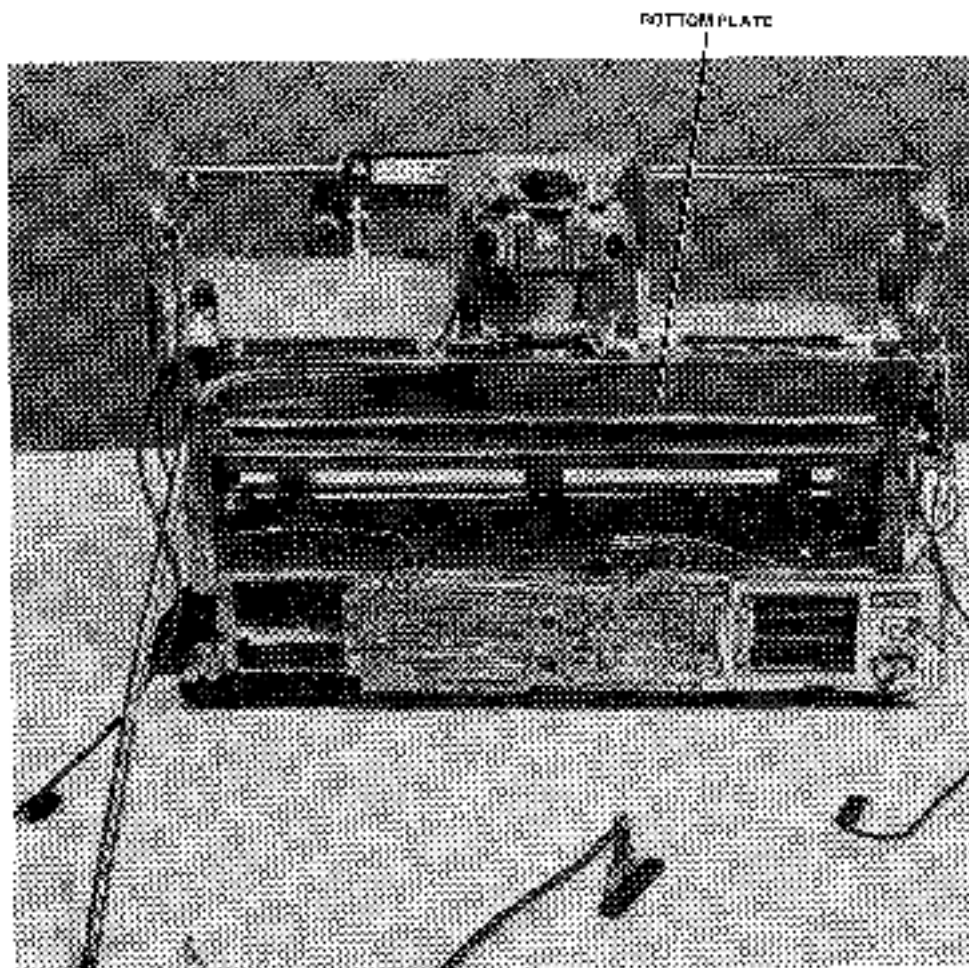

Figure 6-19 Bottom View Showing Connectors, Cables, Tie Wraps, and Attaching Hardware



0044 11

Figure 6-20 Bottom View Showing Connectors Removed

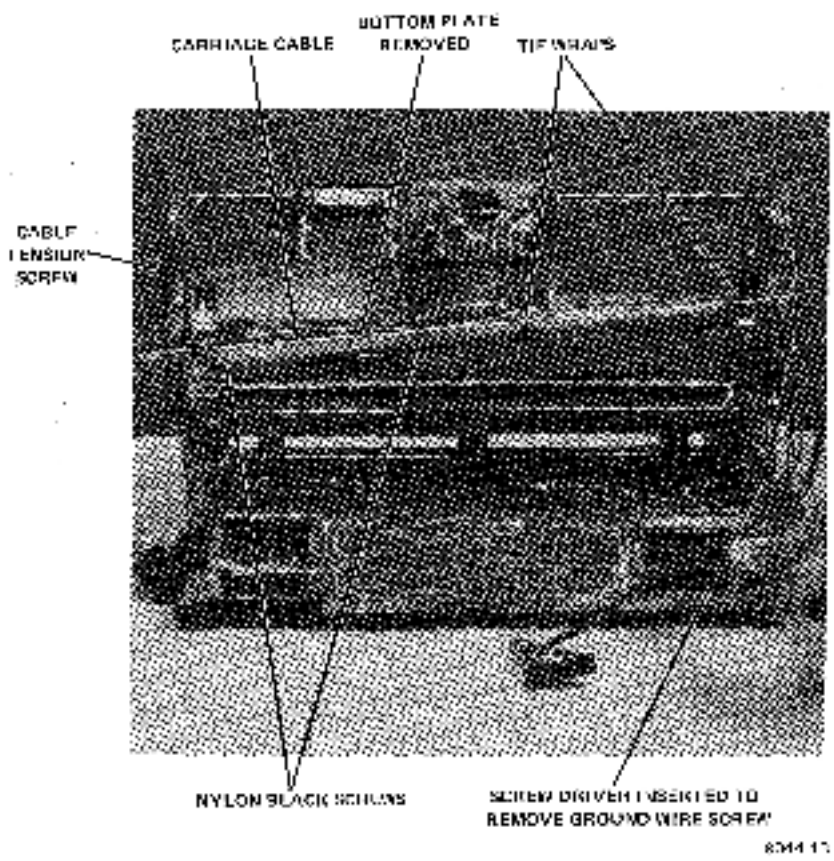
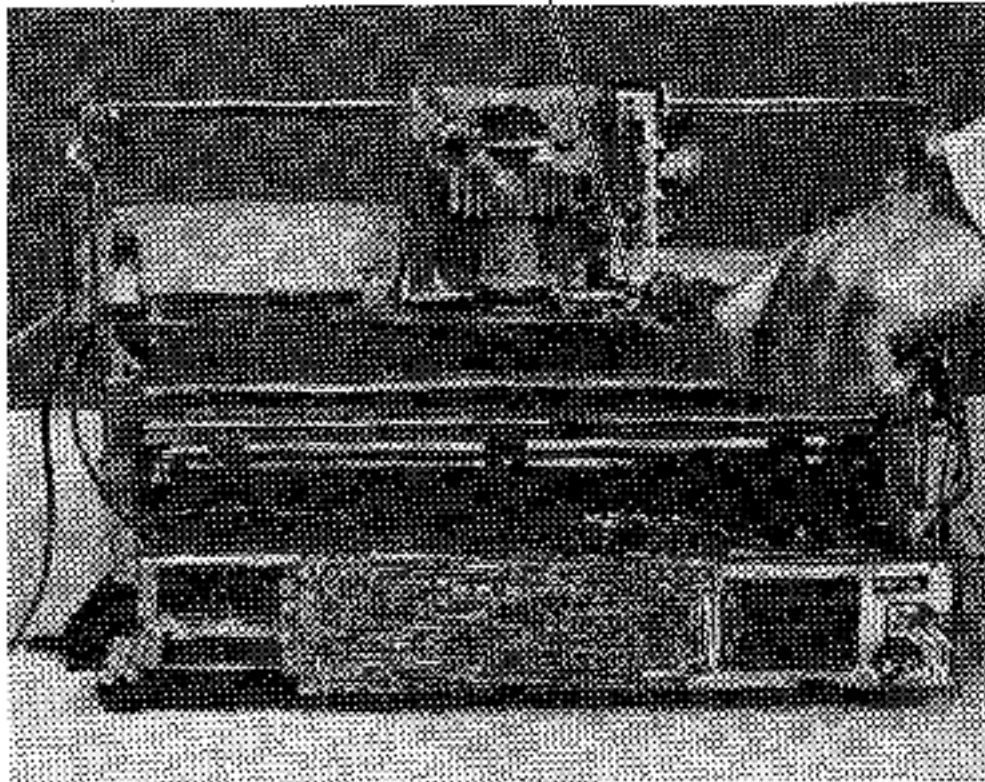

Figure 6-21 Bottom View Showing Bottom Plate Removed

TORK DRIVER INSERTED TO ACCESS  
CARRIAGE PULLEY HOLD DOWN SCREW



024-4

Figure 6-22 Bottom View Showing Carriage Assembly  
Positioned for Carriage Assembly Pulley Access

BOTTOM CARRIAGE ASSEMBLY PULLEY

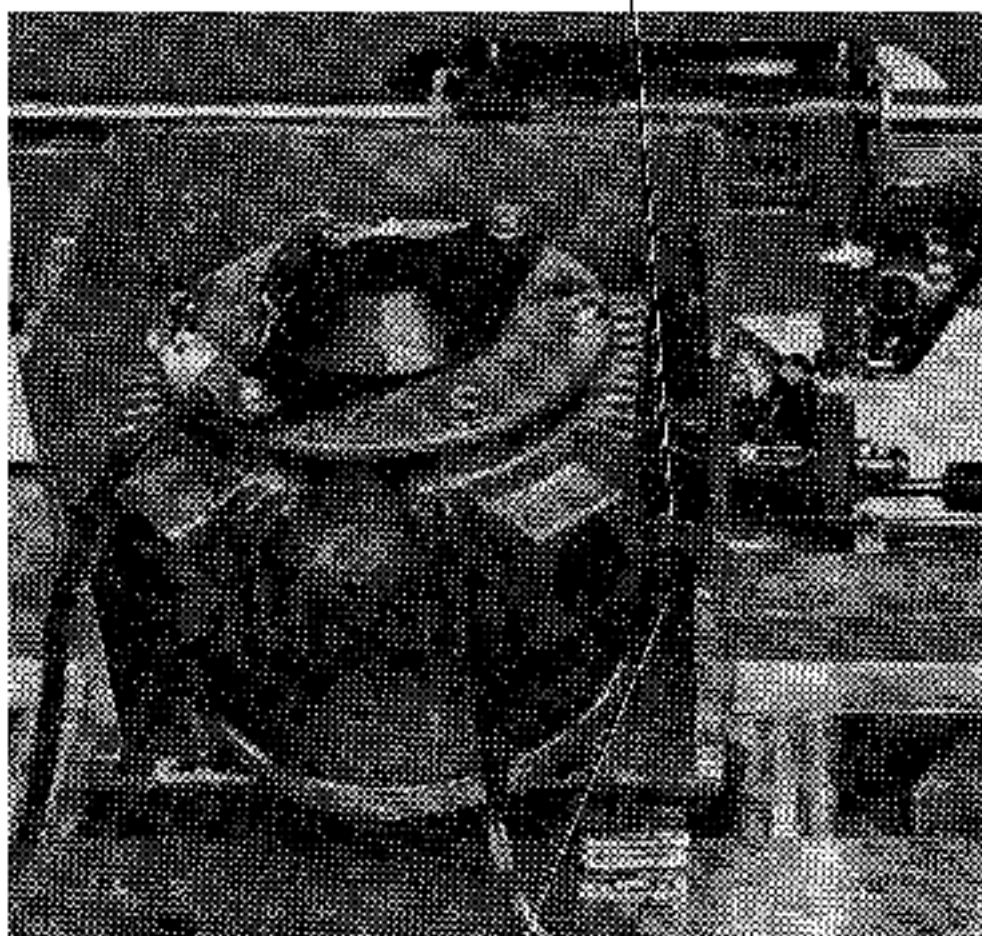

HOLD DOWN SCREW

FIGURE 6-23

Figure 6-23 View Showing Pulley Hold-Down Screw

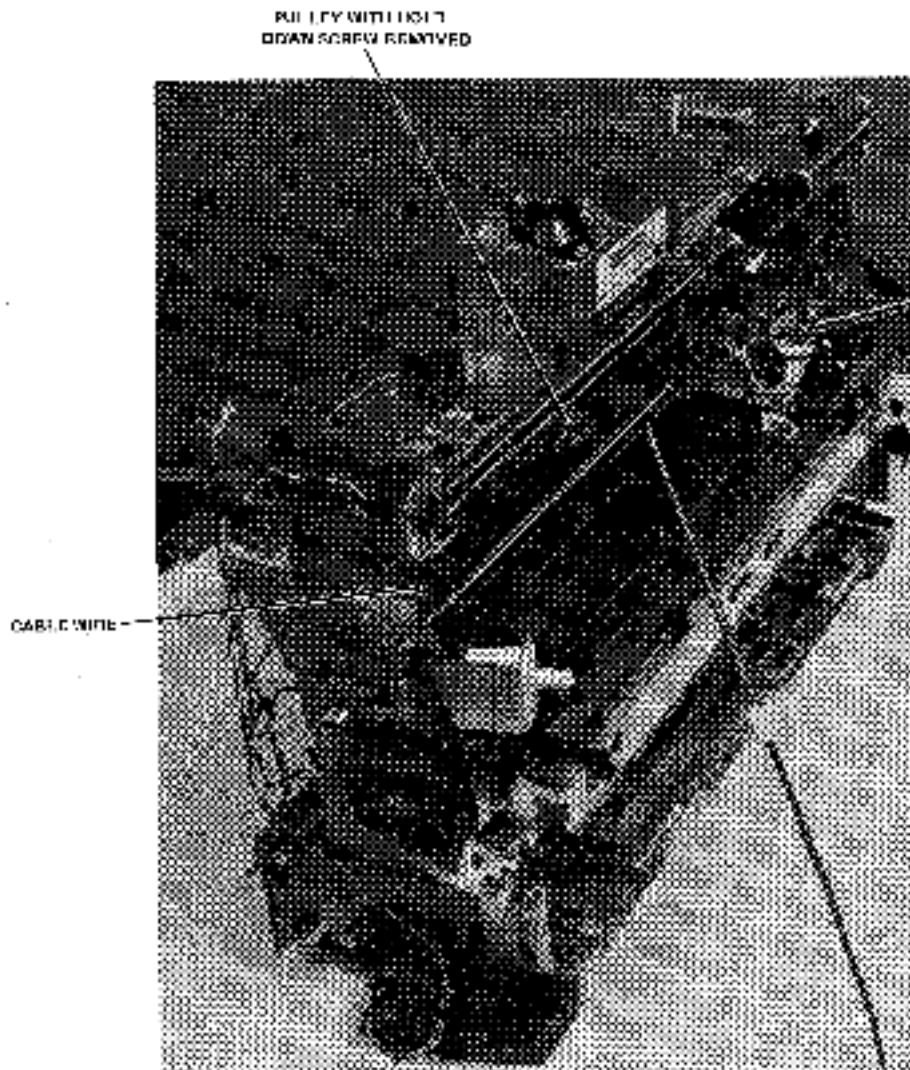
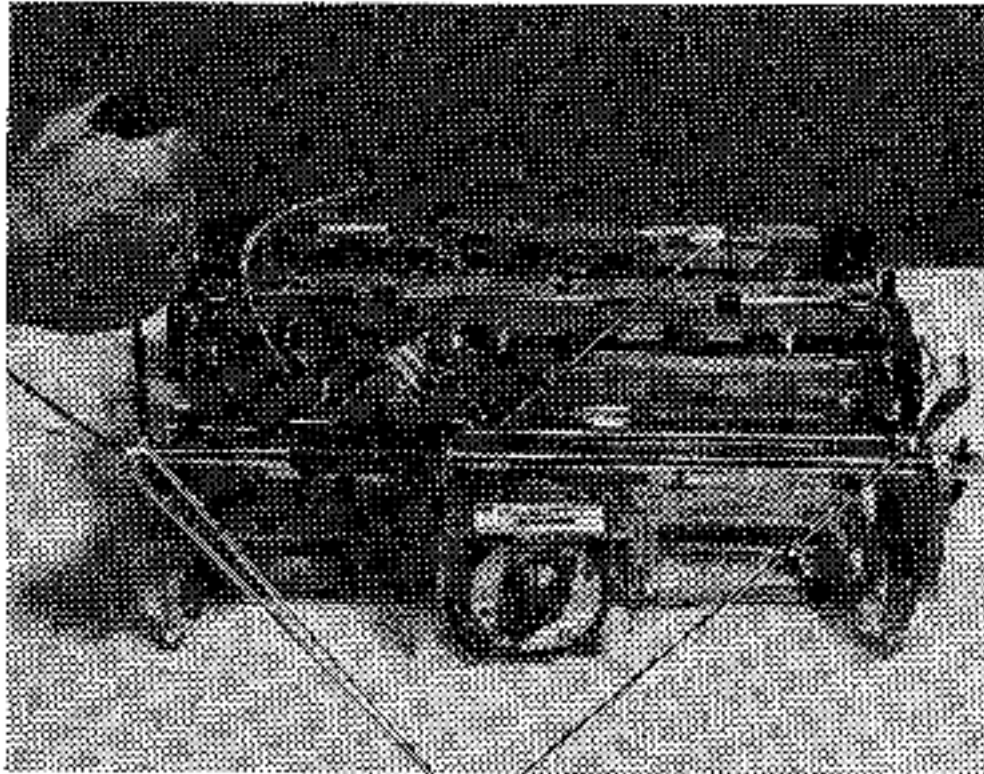

Figure 6-24

Figure 6-24 View Showing Carriage Assembly Bottom  
Pulley with Hold-Down Screw Removed



00467

SLIDE RAIL  
HOLD DOWN SCREWS

Figure 6-25 View Showing Slide Rail Hold-Down Screws

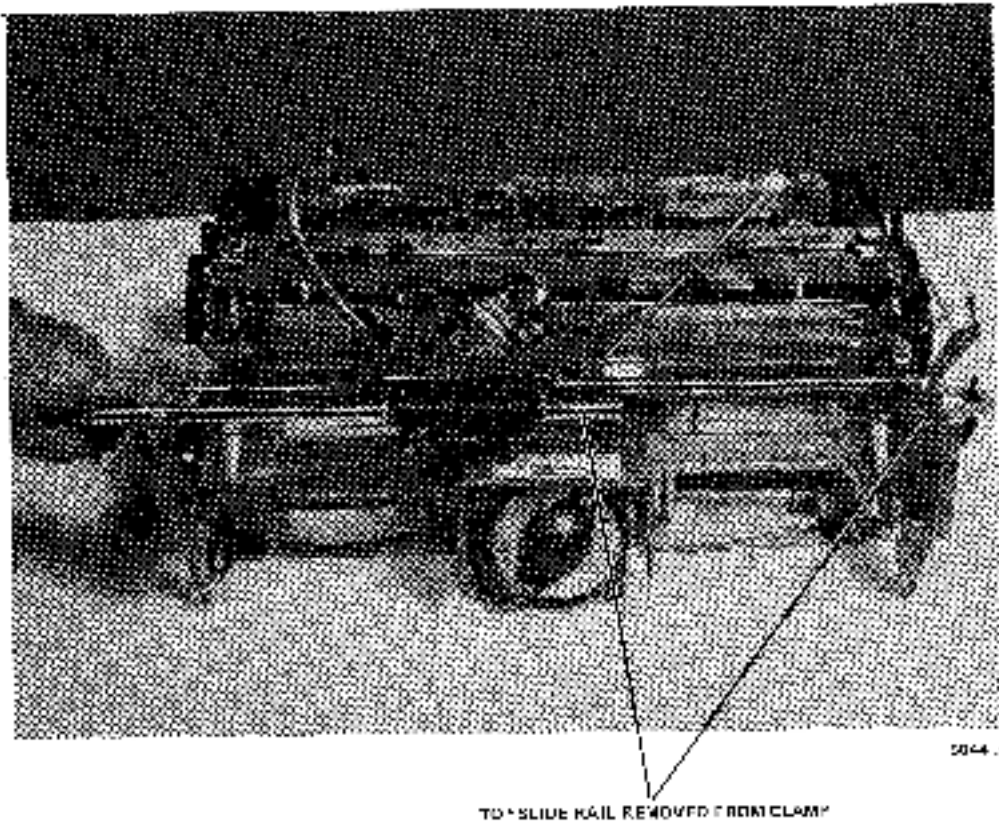

TO SLIDE RAIL REMOVED FROM CLAMP

Figure 6-26 View Showing Top Slide Rail Disengaged from Clamp

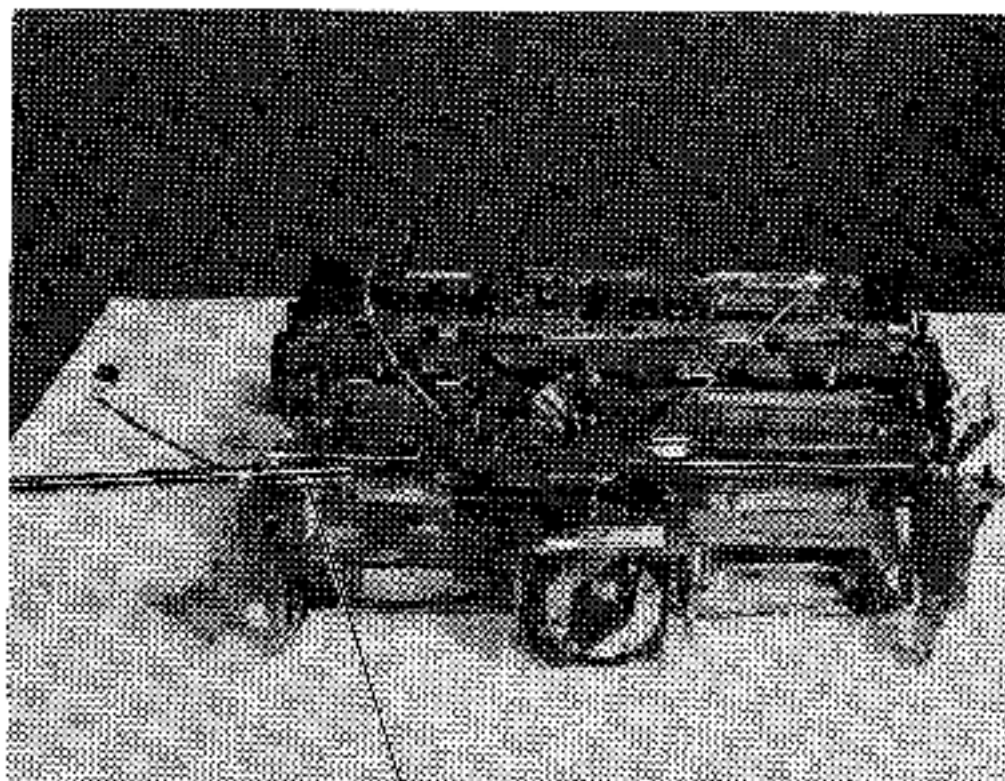

TOP SLIDE RAIL DISENGAGED  
FROM CARRIAGE ASSY

5044-D

Figure 6-27 View Showing Top Slide Rail Disengaged  
from Carriage Assembly

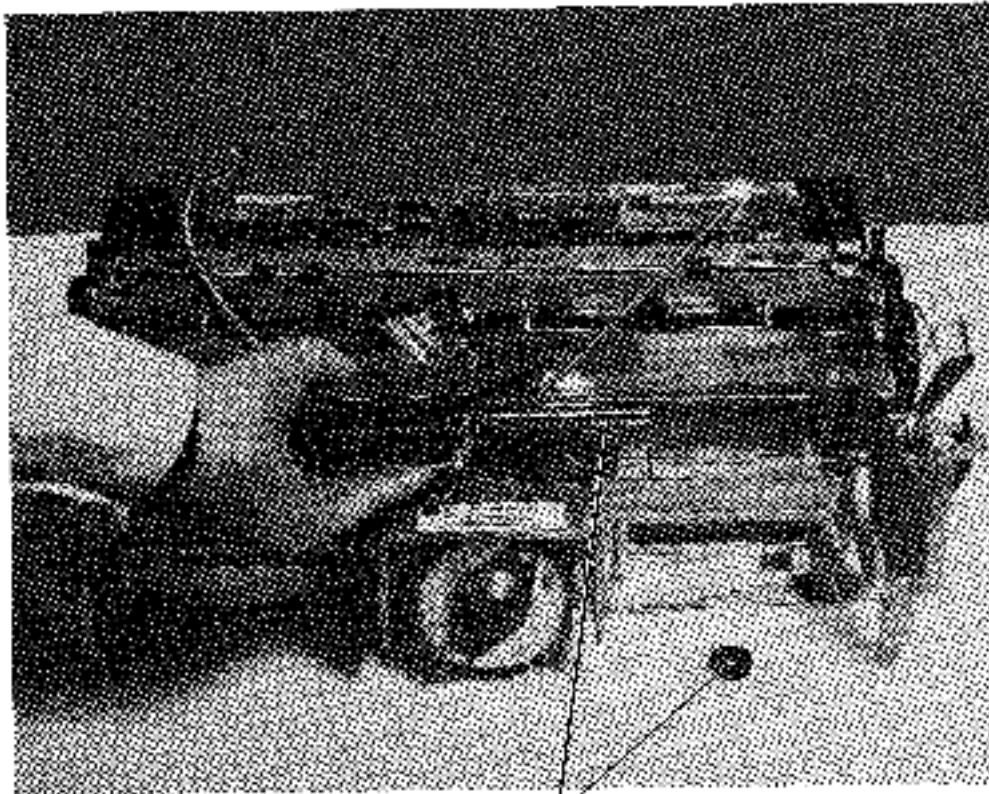

RUBBER BUSHING REMOVED  
FROM BOTTOM SLIDE RAIL

0244 11

Figure 6-28 View Showing Bottom Slide Rail Disengaged from  
Clamp and Rubber Bushing Removed

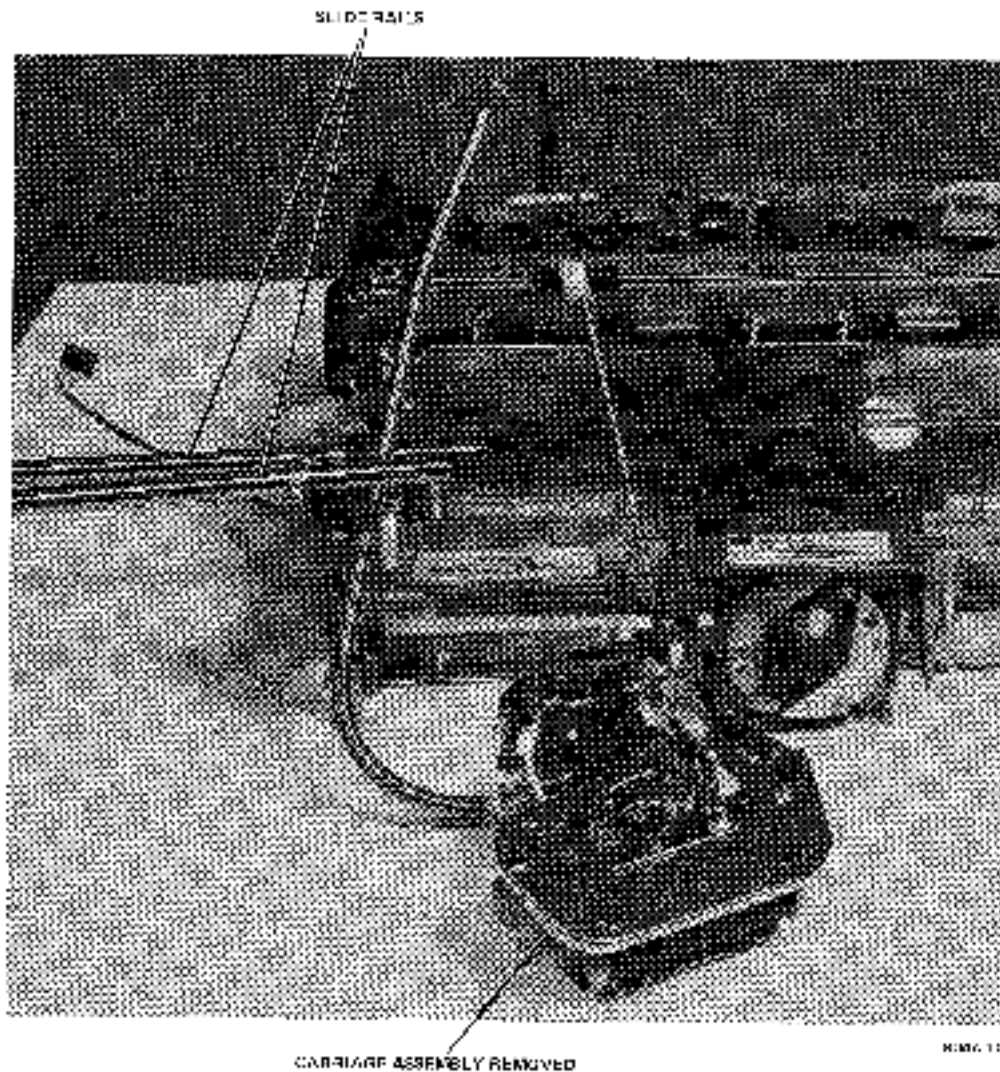

Figure 6-29 View Showing Carriage Assembly  
Removed from Slide Rails

**6.5.3.2 Carriage Replacement Procedure** - Essentially, carriage assembly replacement is accomplished by reversing the removal procedure. It may be necessary to install new rear bearing and card carriage guide assemblies on the new carriage assembly prior to undertaking the replacement procedure. Also, the various alignments such as ribbon lift, print wheel home, hammer angle, and the carriage carrier adjustments must be taken into consideration in the replacement process. When replacing the washer between the pulley and carriage assembly, the addition of grease to the protruding side of the washer will aid in holding it in place. The pulley should be secured before pulling the cables back to the rear of the unit.

**NOTE**

During installation, install top rail first to remove mechanical stress for reinstallation of carriage assembly.

**APPENDIX A**

**MODIFIED ASCII CODE FOR STANDARD PRINT WHEEL**

0100	€	0200	@	0300	
0102	!	0202	A	0302	a
0104	"	0204	B	0304	b
0106	#	0206	C	0306	c
0110	\$	0210	D	0310	d
0112	%	0212	E	0312	e
0114	&	0214	F	0314	f
0116	'	0216	G	0316	g
0120	(	0220	H	0320	h
0122	)	0222	I	0322	i
0124	*	0224	J	0324	j
0126	+	0226	K	0326	k
0130	,	0230	L	0330	l
0132	-	0232	M	0332	m
0134	.	0234	N	0334	n
0136	/	0236	O	0336	o
0140	0	0240	P	0340	p
0142	1	0242	Q	0342	q
0144	2	0244	R	0344	r
0146	3	0246	S	0346	s
0150	4	0250	T	0350	t
0152	5	0252	U	0352	u
0154	6	0254	V	0354	v
0156	7	0256	W	0356	w
0160	8	0260	X	0360	x
0162	9	0262	Y	0362	y
0164	:	0264	Z	0364	z
0166	;	0266	[	0366	{
0170	<	0270	\	0370	
0172	=	0272	]	0372	}
0174	>	0274	^	0374	~
0176	?	0276	_	0376	~

NOTES:

1. Octal numbers are actually a modified ASCII which is shifted left one position. See example on next page.
2. Actual positioning of characters on print wheel is shown in Appendix B.

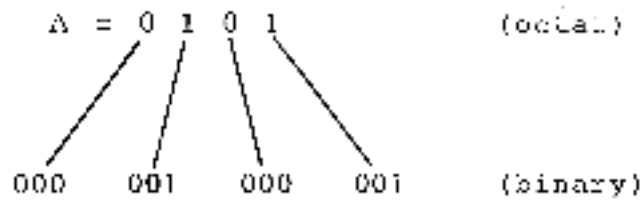

**Standard ASCII Example**

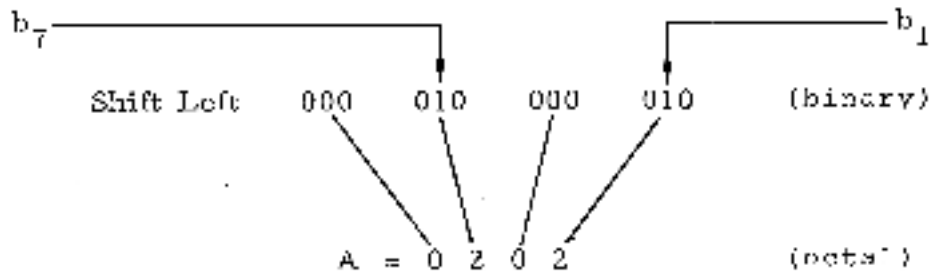

**Modified ASCII Example**

Figure A-1 Modified ASCII Example

## APPENDIX B POSITION OF CHARACTERS ON PRINT WHEEL

[ 2 ] c	[37] o	[62] @	[20] P	[66] ,	[96] p
[68] l	[33] 1	[11] A	[27] Q	[64] a	[92] q
[70] "	[34] 2	[ 8 ] B	[13] R	[78] b	[81] r
[48] #	[35] 3	[10] C	[14] S	[79] c	[83] s
[44] \$	[36] 4	[22] D	[16] T	[75] d	[80] t
[47] %	[38] 5	[15] E	[23] U	[83] e	[91] u
[69] &	[39] 6	[ 9 ] F	[30] V	[89] f	[73] v
[54] '	[40] 7	[24] G	[ 4 ] W	[74] g	[ 0 ] w
[60] {	[41] 8	[17] H	[32] X	[87] h	[75] x
[58] }	[12] 9	[20] I	[25] Y	[86] i	[94] y
[61] *	[12] :	[29] J	[ 7 ] Z	[73] j	[95] z
[46] +	[31] ;	[28] K	[53] [	[93] k	[49] {
[ 3 ] ,	[57] <	[21] L	[63] \	[77] l	[59] }
[43] .	[40] =	[ 6 ] M	[51] ]	[71] m	[67] }
[ 5 ] ,	[50] >	[19] N	[64] ^	[82] n	[52] ~
[66] /	[65] ?	[18] O	[55] -	[60] o	[ 1 ] _

[ ] Print wheel spoke position as viewed from the character side of the print wheel

Figure B-1 Print Wheel Characters



## APPENDIX C INTERFACE WIRING DETAILS

Figure C-1 shows the interconnections between the PDP-8 Omnibus, the LQP8-E controller, the LQP01 printer, and the ac/dc power supply in a typical LQP8 printer system. Actual pin assignments are listed in Tables C-1 and C-2.

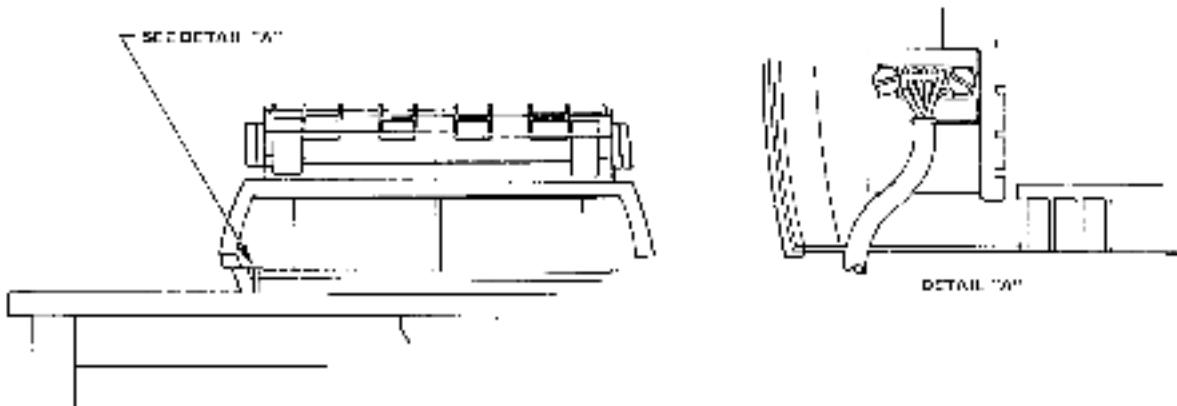
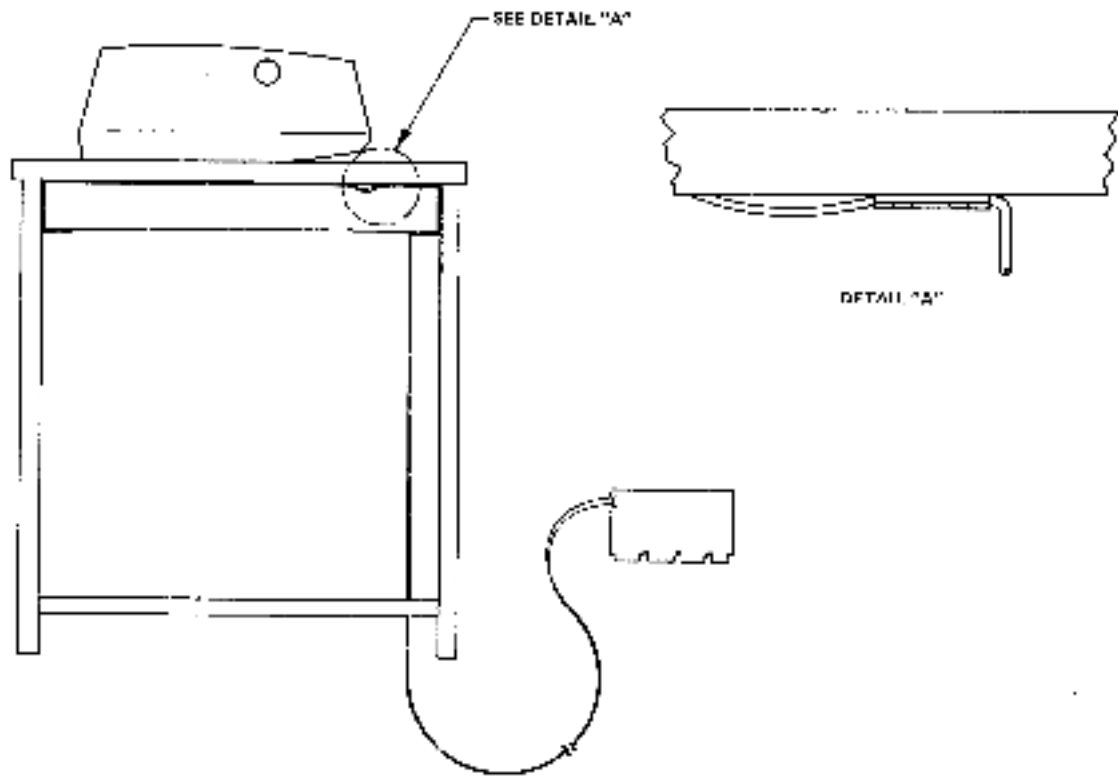

CD-1043

Figure C-1 Interconnection Diagram for Typical I.QP8 Printer System

**Table C-1 Pin Assignments on LQP8-E Controller Module Connector J1\***

Pin	Signal Name	Pin	Signal Name
1	Gnd	26	Top of Form
2	Data 1/2	27	Gnd
3	Data 1	28	Lift Blk
4	Data 2	29	Gnd
5	Data 4	30	Lift Red
6	Data 8	31	Gnd
7	Data 16	32	Printer Select
8	Data 32	33	Gnd
9	Data 64	34	Bail Disengage
10	Data 128	35	Gnd
11	Data 256	36	Gnd
12	Data 512	37	Check
13	Data 1024	38	Gnd
14	Unused	39	Character Ready
15	Gnd	40	Gnd
16	Restore	41	Carriage Ready
17	Gnd	42	Gnd
18	Character Strobe	43	Paper Right Ready
19	Gnd	44	Gnd
20	Carriage Strobe	45	Paper Left Ready
21	Gnd	46	Gnd
22	Right Paper Strobe	47	Printer Ready
23	Gnd	48	Gnd
24	Left Paper Strobe	49	Paper Out
25	Gnd	50	Gnd

\*See Table S-2 for the function of these interface signals.

Table C-2 Pin Assignments on Power Supply Connector P4

Recommended wire within power cable is UL APPROVED, type 1095, 300 volt.

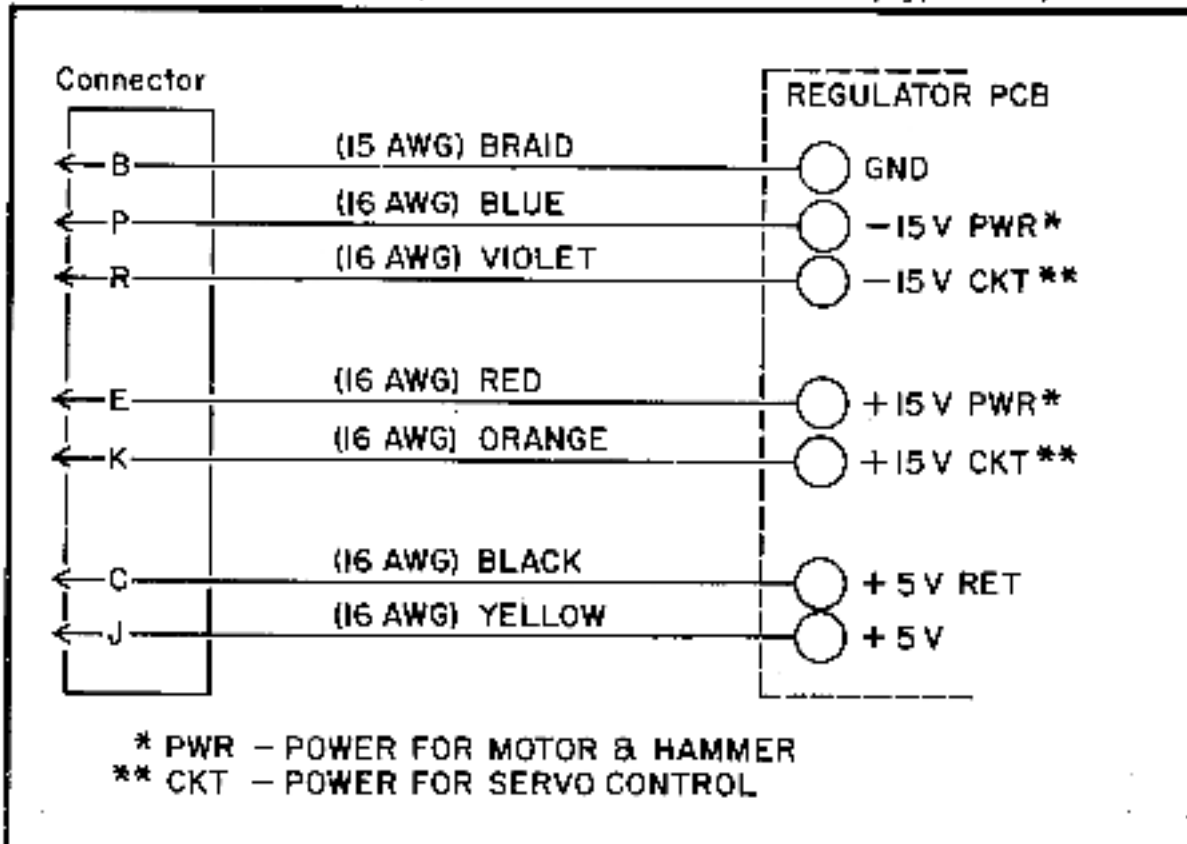

**APPENDIX D**  
**DETAILS OF INTEGRATED CIRCUITS**  
**ON LQP8-E CONTROLLER**

This appendix contains logic diagrams and other technical data on the following integrated circuits:

7442  
7474  
74123  
74174  
74175  
8136

### 74123 RETRIGGERABLE MONOSTABLE MULTIVIBRATOR

The 74123 Monostable Multivibrator provides d-c triggering from gated low-level active (A) and high level active (B) inputs. Overriding direct clear inputs and complementary outputs are also provided.

By triggering the input before the output pulse is terminated, the output pulse may be extended. The overriding clear capability permits any output pulse to be terminated at a predetermined time, independently of the external timing components.

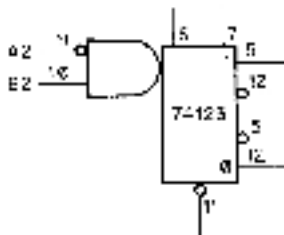
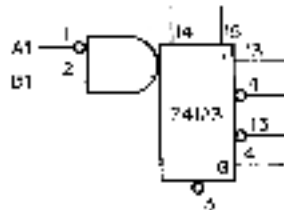

—5V +PIN 15  
—2N J +PIN 1

IC 74123

TRUTH TABLE

INPUTS		OUTPUTS	
A	B	Q	Q'
H	X	L	H
X	L	L	H
L	L	L	H
L	H	H	L

NOTE: H = high level (steady state), L = low level (steady state),  $\uparrow$  = transition from low to high level,  $\downarrow$  = transition from high to low level,  $\square$  = one high level pulse,  $\square$  = one low-level pulse, X = irrelevant (any input, including transitional)

00-7123-02

### 7442 4 LINE TO 1 LINE DECODER

These BCD-to-decimal decoders consist of eight inverters and ten 4-input NAND gates. The inverters are connected in pairs to make BCD input data available for decoding by the NAND gates.

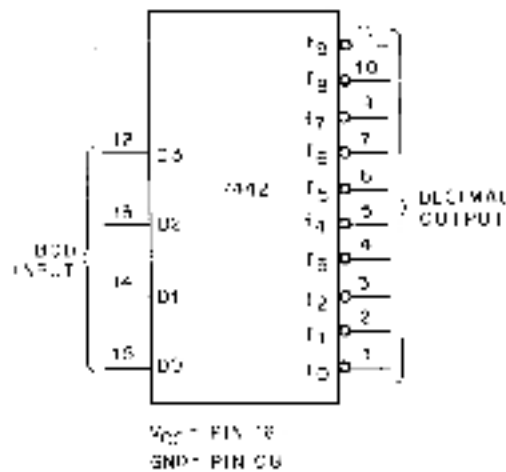

IC 7442

7442  
TRUTH TABLE

BCD Input				Decimal Output									
D3	D2	D1	D0	10	11	12	13	14	15	16	17	18	19
0	0	0	0	0	1	1	1	1	1	1	1	1	1
0	0	0	1	1	0	1	1	1	1	1	1	1	1
0	0	1	0	1	1	0	1	1	1	1	1	1	1
0	0	1	1	1	1	1	0	1	1	1	1	1	1
0	1	0	0	1	1	1	1	0	1	1	1	1	1
0	1	0	1	1	1	1	1	1	0	1	1	1	1
0	1	1	0	1	1	1	1	1	1	0	1	1	1
0	1	1	1	1	1	1	1	1	1	1	0	1	1
1	0	0	0	1	1	1	1	1	1	1	1	1	0
1	0	0	1	1	1	1	1	1	1	1	1	1	1
1	0	1	0	1	1	1	1	1	1	1	1	1	1
1	0	1	1	1	1	1	1	1	1	1	1	1	1
1	1	0	0	1	1	1	1	1	1	1	1	1	1
1	1	0	1	1	1	1	1	1	1	1	1	1	1
1	1	1	0	1	1	1	1	1	1	1	1	1	1
1	1	1	1	1	1	1	1	1	1	1	1	1	1

### 8136 6-BIT, UNIFIED-BUS COMPARATOR

The 8136 compares two binary words (from 2 to 6 bits in length) and indicates matching bit-for-bit of the two words. Inputs for one word are TTL, while those of the second word are high impedance receivers driven by a terminated data bus. The transfer of information to the output occurs as long as the STB input is logic 0. Inputs may be changed while the STB input is at the logic 1 level without affecting the state of the output.

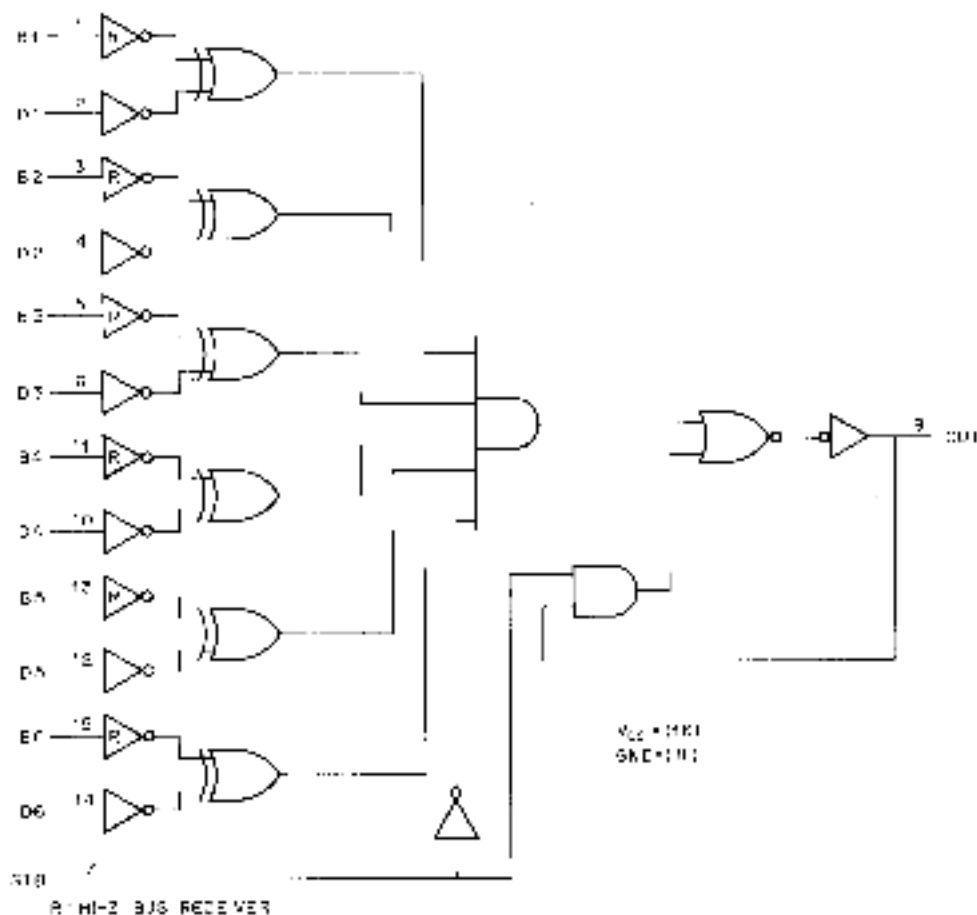

# 74175 Quad Storage Register

TRUTH TABLE

INPUT	OUTPUT
$I_n$	$Q_n$
0	0 (L)
1	1 (H)

$I_n$  - Bit line before clock pulse.  
 $Q_n$  - Bit line after clock pulse.

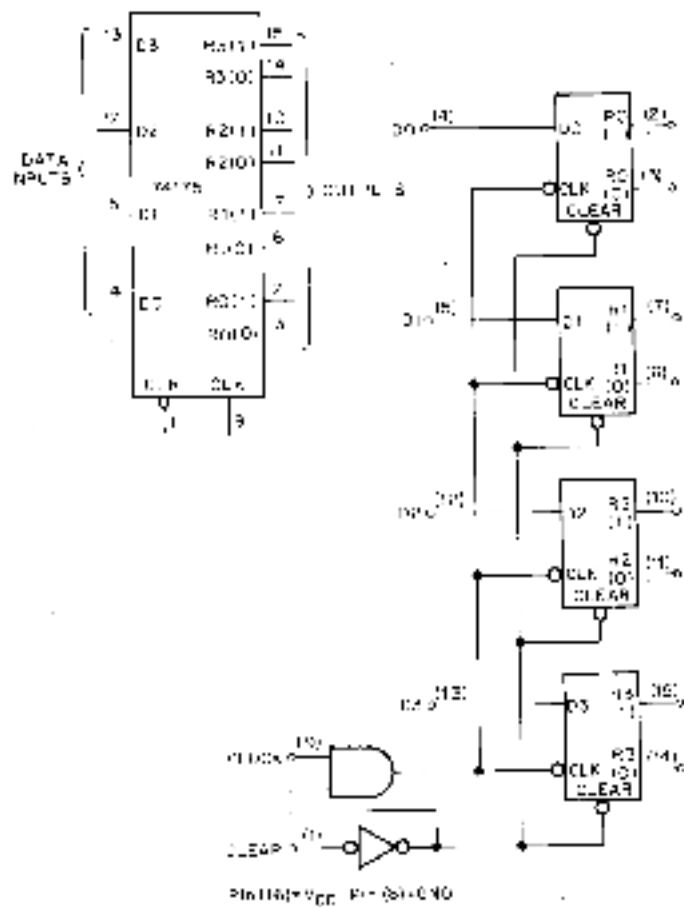

# 74174 HEX D FLIP-FLOP REGISTER

TRUTH TABLE

INPUT $T_n$	OUTPUT $Q_n$
0	$\bar{Q}(1)$
1	H
-	L

$T_n$  - All time before clock pulse.  
 $T_n$  - 1-10% time after clock pulse.

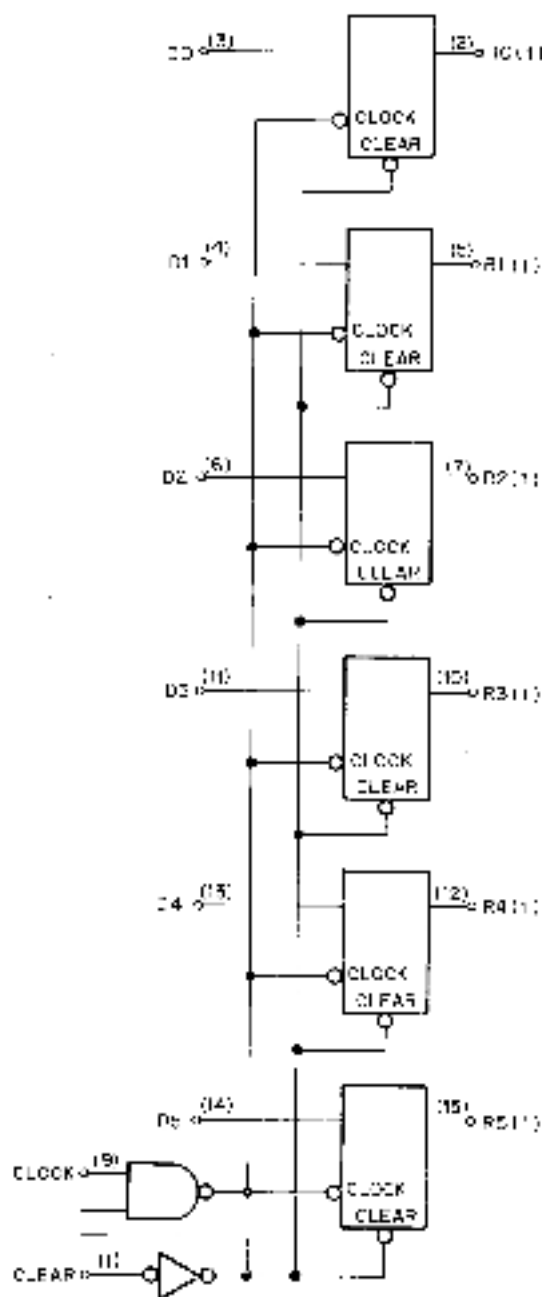
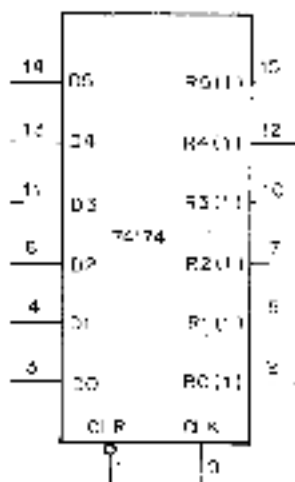

Pin (16) =  $V_{CC}$ , Pin (18) = GND

10-14174-1

# 7474 Dual Flip-Flop

TRUTH TABLE FOR  
7474 STANDARD CONFIGURATION  
(J-K FLIP-FLOP)

Q <sub>1</sub>		Q <sub>2</sub>		
Pin 1 (J)	Pin 2 (K)	Pin 2 (J)	Pin 5 (K)	Pin 6 (Q)
High	High	Low	Low	High
High	Low	High	High	Low
Low	High	X	X	High
Low	Low	X	X	Low

X = indeterminate output.  
 1 = high level after user setup.  
 0 = low level.  
 X = no connection.

## STANDARD CONFIGURATION



VCC = Pin 14  
 GND = Pin 07

## REFINED CONFIGURATION

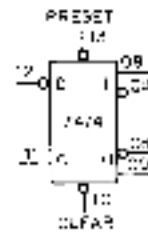
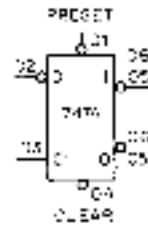

VCC = Pin 14  
 GND = Pin 07



## APPENDIX E TROUBLESHOOTING FLOWCHART

Table E-1 and Figure E-1 are designed to be quick reference guides to isolate problems within the LQP8 printer system. More detailed procedures and adjustments are described in Chapters 5 and 6 of this manual.

**Table E-1 LQP8 System Problems**

Symptom	Possible Solution
Uneven density of characters	<p>For top and bottom of characters adjust:</p> <ul style="list-style-type: none"> <li>Platen height</li> <li>Ribbon lift</li> <li>Platen to print wheel (PW) gap</li> </ul> <p>For sides of characters adjust:</p> <ul style="list-style-type: none"> <li>PW alignment</li> <li>PW home</li> </ul>
Print wheel spins continuously on power up.	<p>Adjust the distance between magnetic pickup and PW flag for 0.001. Another technique is to adjust this distance until 550 MV appears at D20 on servo board.</p> <p>Replace carriage assembly.</p>
Print wheel home position is off by character. Carriage does not move on power up.	<p>Adjust magnetic pickup eccentric by turning brass nut.</p> <p>Replace carriage assembly.</p> <p>Check fuses on +15 V power supply.</p> <p>Replace carriage amp PCB.</p>
No ribbon lift.	<p>Adjust ribbon coil.</p> <p>Adjust ribbon eccentric.</p> <p>Replace PW amp PCB.</p>
Mylar ribbon broke.	<p>Check for rough edge on ribbon guide.</p> <p>Adjust card guide.</p> <p>Replace ribbon cartridge.</p>
Prints incorrect (random character)	<p>Replace PW amp PCB.</p> <p>Replace carriage assembly.</p>

Table E-1 LQP8 System Problems (Cont)

Symptom	Possible Solution
Erratic paper feed	Adjust eccentric on paper feed plastic gear (85T). Bud paper feed motor Replace carriage amp PCB. Replace platen.
No ribbon drive	Replace ribbon cartridge Print wheel power amp card Logic #2 board Ribbon motor
Erratic stepping of carriage	Transducer board Carriage power amp board Servo board Logic #2 Logic #1 Replace carriage assembly.
Carriage homes to the right.	Carriage home sensor is shorted.
Status error: no "character ready signal"	Character print wheel home position time/voltage off Adjust carriage home position sensor.

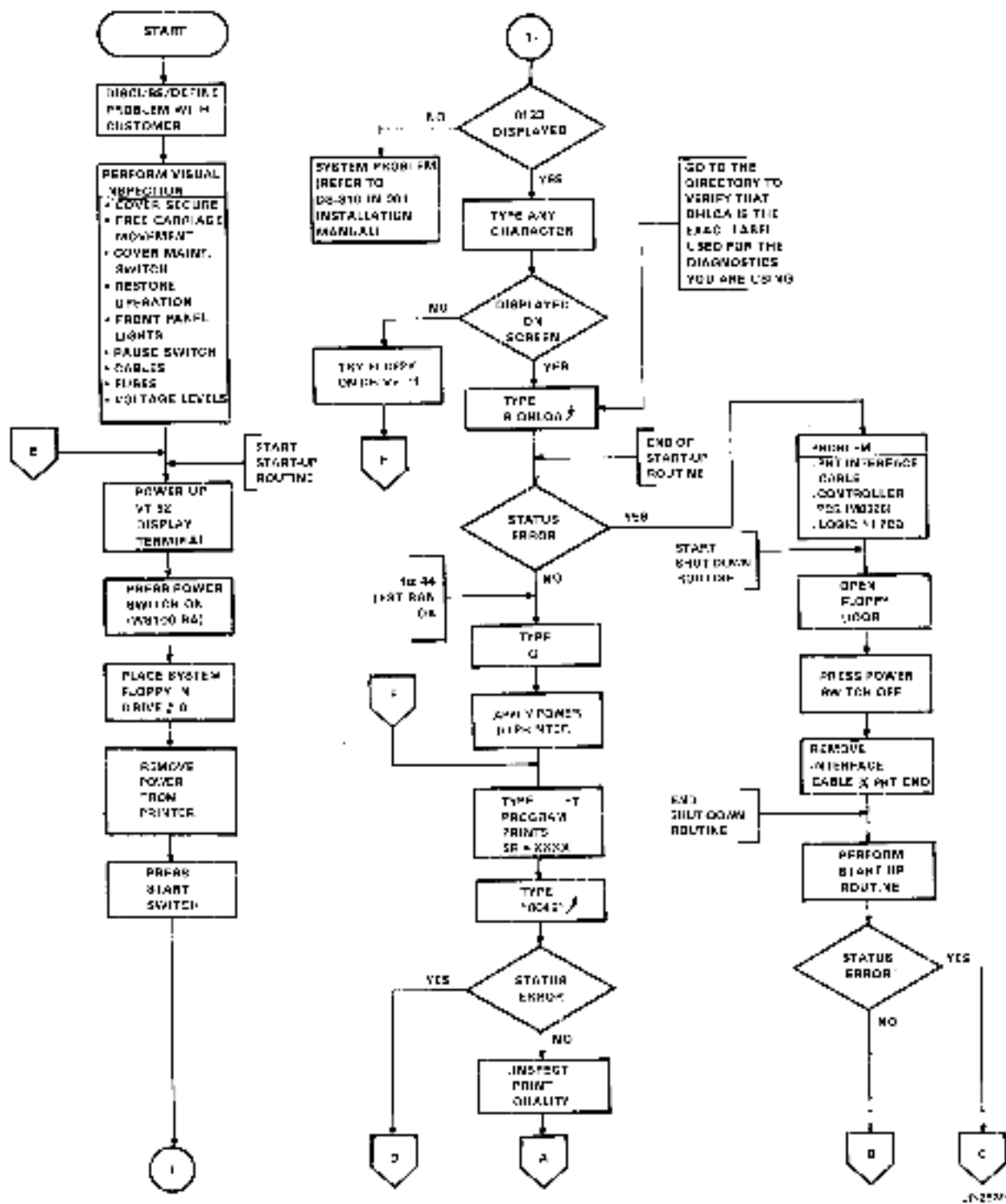
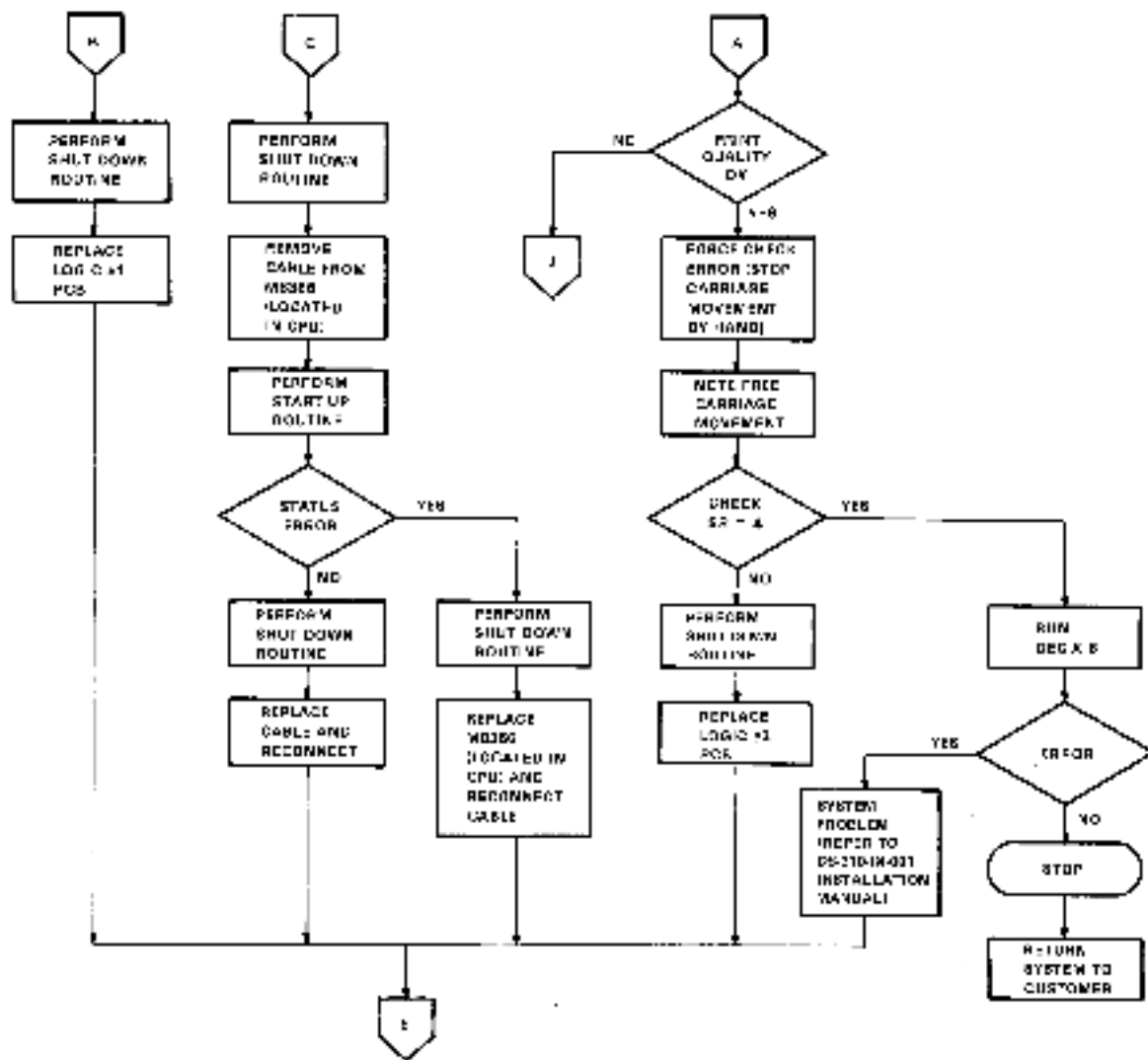

Figure E-1 LQ8 Troubleshooting Flowchart (Sheet 1 of 6)



11-2441

Figure E-1 LQP8 Troubleshooting Flowchart (Sheet 2 of 6)

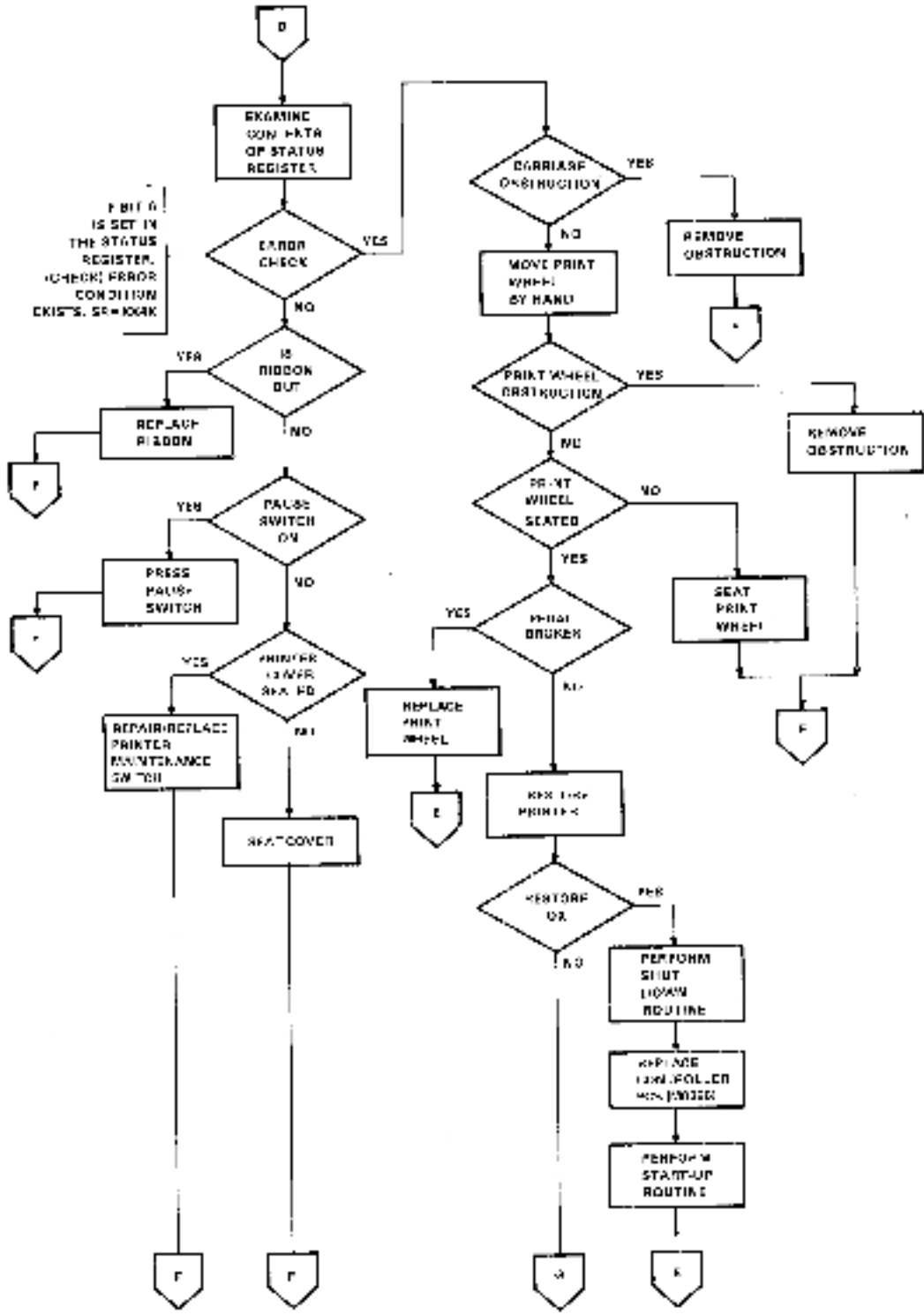

Figure E-1 LQP8 Troubleshooting Flowchart (Sheet 3 of 6)

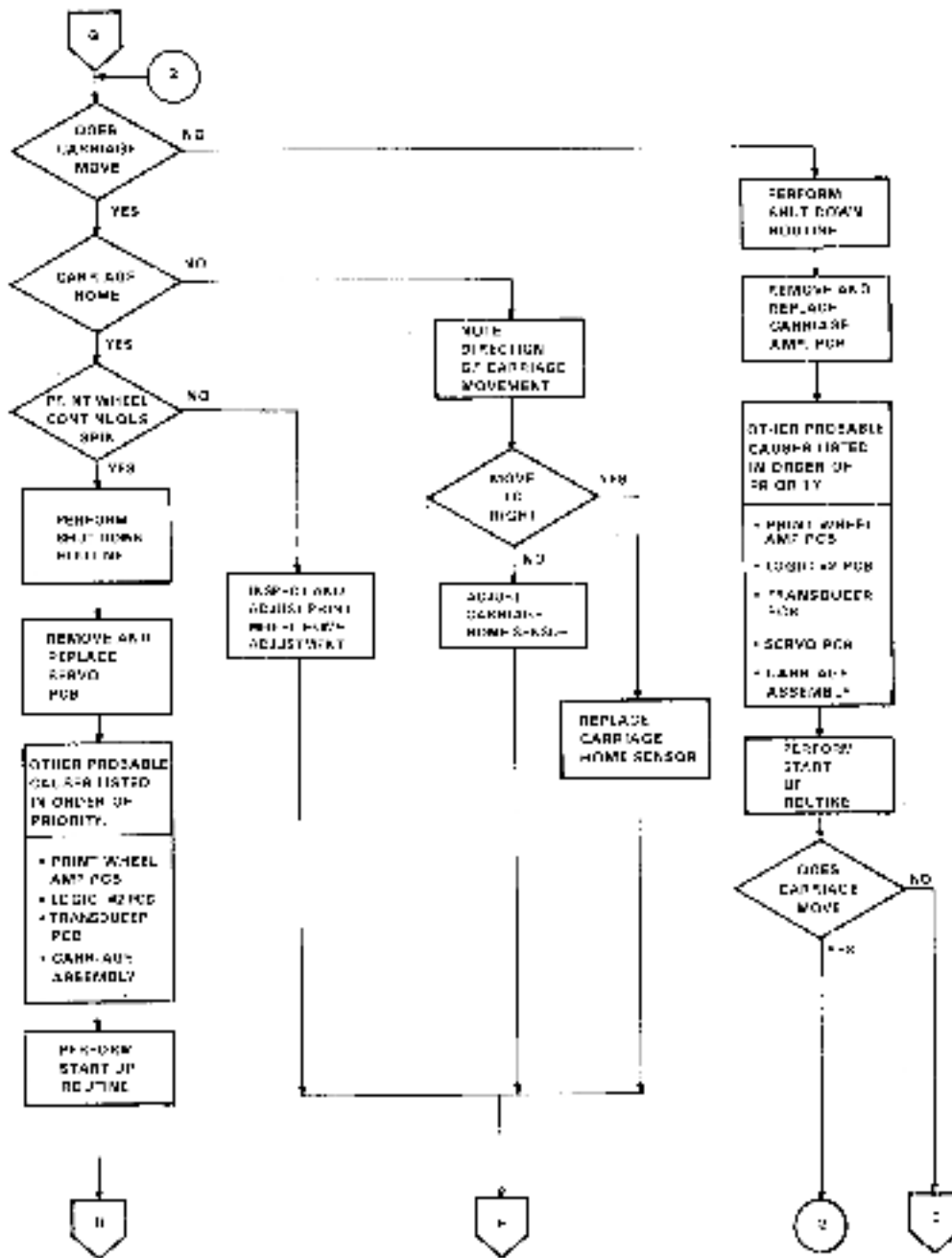
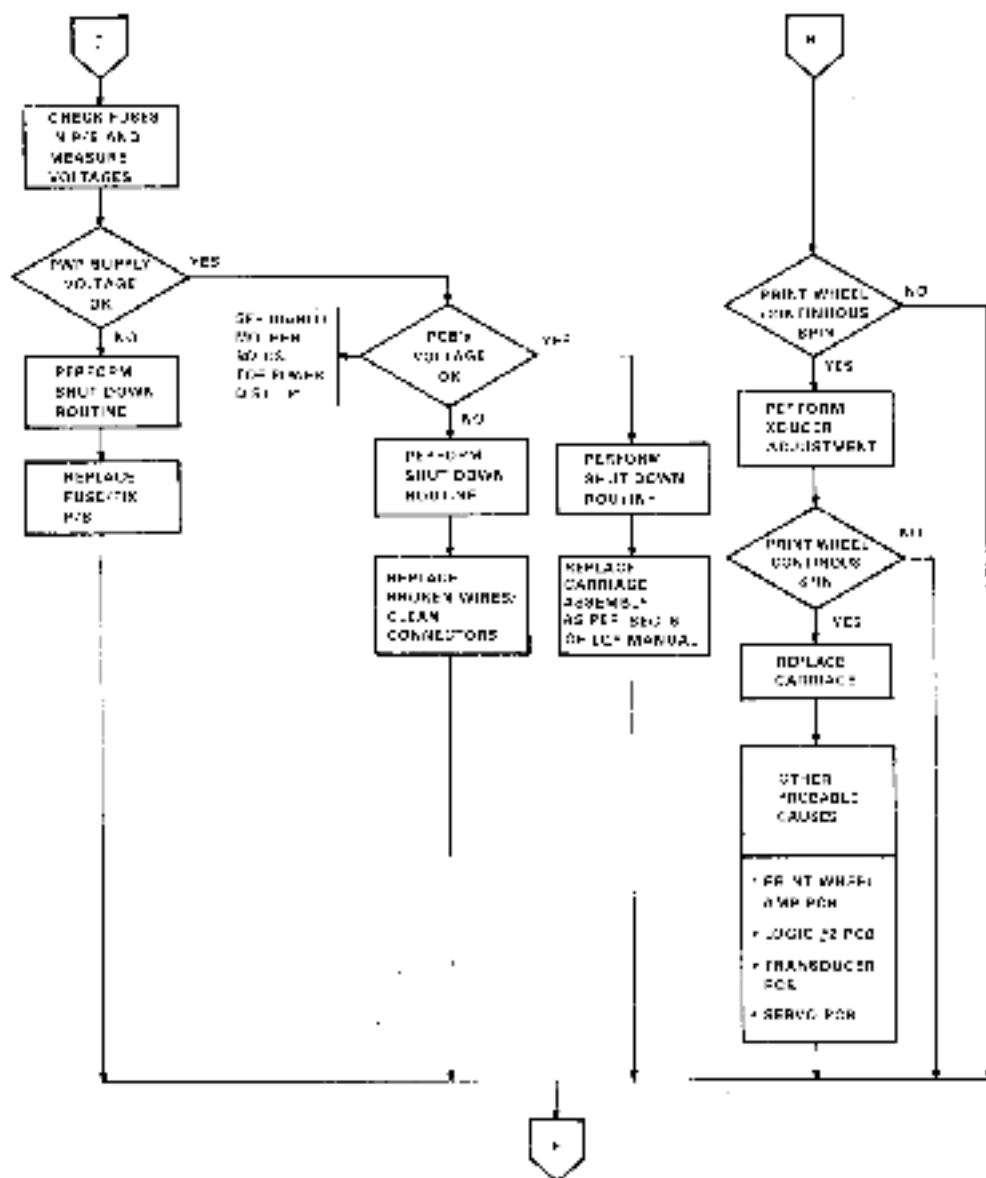

Figure E-1 LQP8 Troubleshooting Flowchart (Sheet 4 of 6)



75-1004

Figure E-1 LQP8 Troubleshooting Flowchart (Sheet 5 of 6)



## APPENDIX F LQP8-F SERIAL PRINTER

### F.1 SCOPE

This appendix is written as a reference document to support DIGITAL Field Service personnel in maintaining the LQP8-F serial printer.

### F.2 INTRODUCTION

The LQP8-F serial printer is a modified LQP01 that processes data from an asynchronous serial line.

The LQP8-F consists of an LQP01 printer with the LQPXX-CS option (a serial-to-parallel signal converter interface) installed. The LQPXX-CS, consisting of two modules, is inserted into the two empty slots in the LQP01 printer. This interface converts Electronic Industries Association (EIA) RS-232-C level input signals to parallel data, which is used by the LQP01 printer.

The LQPXX-CS is 8085A microprocessor based. The interface microprocessor is self-starting at power up and runs a fixed program. The fixed program is capable of exercising the interface and printer in self-test mode.

Two versions of the LQP8-F are available:

- LQP8-FA for 120 V, 60 Hz
- LQP8-FD for 240 V, 50 Hz

The LQPXX-CS is an add-on option to either the LQP8-F or the LQP78-P printer. When the LQPXX-CS is added to the LQP01 printer, the result is the LQP8-F serial printer.

#### F.2.1 Equipment Supplied

Table F-1 lists the quantity and DIGITAL part number for each item supplied with the LQPXX-CS serial printer interface option.

**Table F-1 Equipment Supplied with the LQPXX-CS**

Quantity	Name	DIGITAL Part No.
1	LQP Serial Interface (Mother)	5413937-00
1	LQP Serial Interface (Daughter)	5413935-00
1	Cable, Mother/Daughter Power	7015506-00
1	Cable, Mother/Daughter Signal	7017247-00
1	Cable, Option Control	7017235-11
1	Cable, Serial Input	7017236-1C
1	Connector Bracket	7423178-00
1	Cable, Printer Signal	BC302D-1B

**NOTE**

Refer to the Field Maintenance Print Set Parts List for DIGITAL part numbers of mounting hardware, brackets, and connectors.

**F.2.2 Physical Description**

The LQPXX-CS serial printer interface consists of two printed circuit boards (PCBs) and associated cables, as shown in Figure F-1. These two PCBs (mother and daughter boards) are physically and electrically connected and are removed and installed as a dual PCB package. Only the mother board plugs into the LQP111 printer mother board.

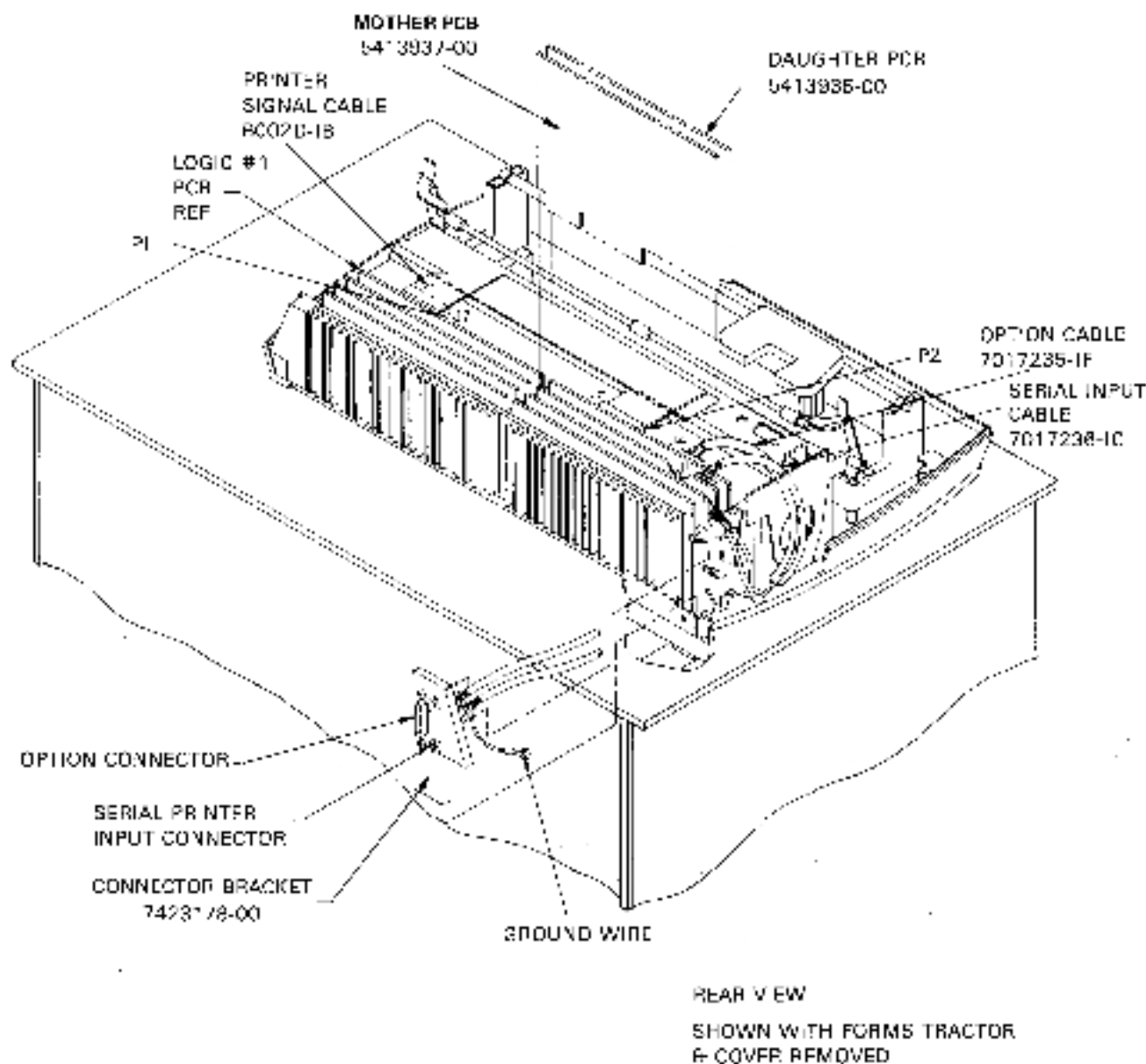

VK 2233

Figure F-1 LQPXX-CS Serial Interface Components

The mother and daughter boards are connected together with snap-in fasteners. They are interconnected by a power cable and a signal cable to create a mother/daughter pair. The mother board is 14.22 by 19.69 cm (5.6 by 7.750 inches), and the daughter board is 13.46 by 19.69 cm (5.3 by 7.750 inches). The snap-in fasteners space the boards 1.43 cm (0.56 inches) apart and hold them together.

Three cables attach to the interface. Two of the cables extend outside the LQP01 printer case at the rear: one connects the interface to the supporting RS-232-C device, and the other connects the interface to the option connector. The third cable connects the interface to the LQP01 at the Logic #1 PCB. Figure F-2 illustrates the cable connections.

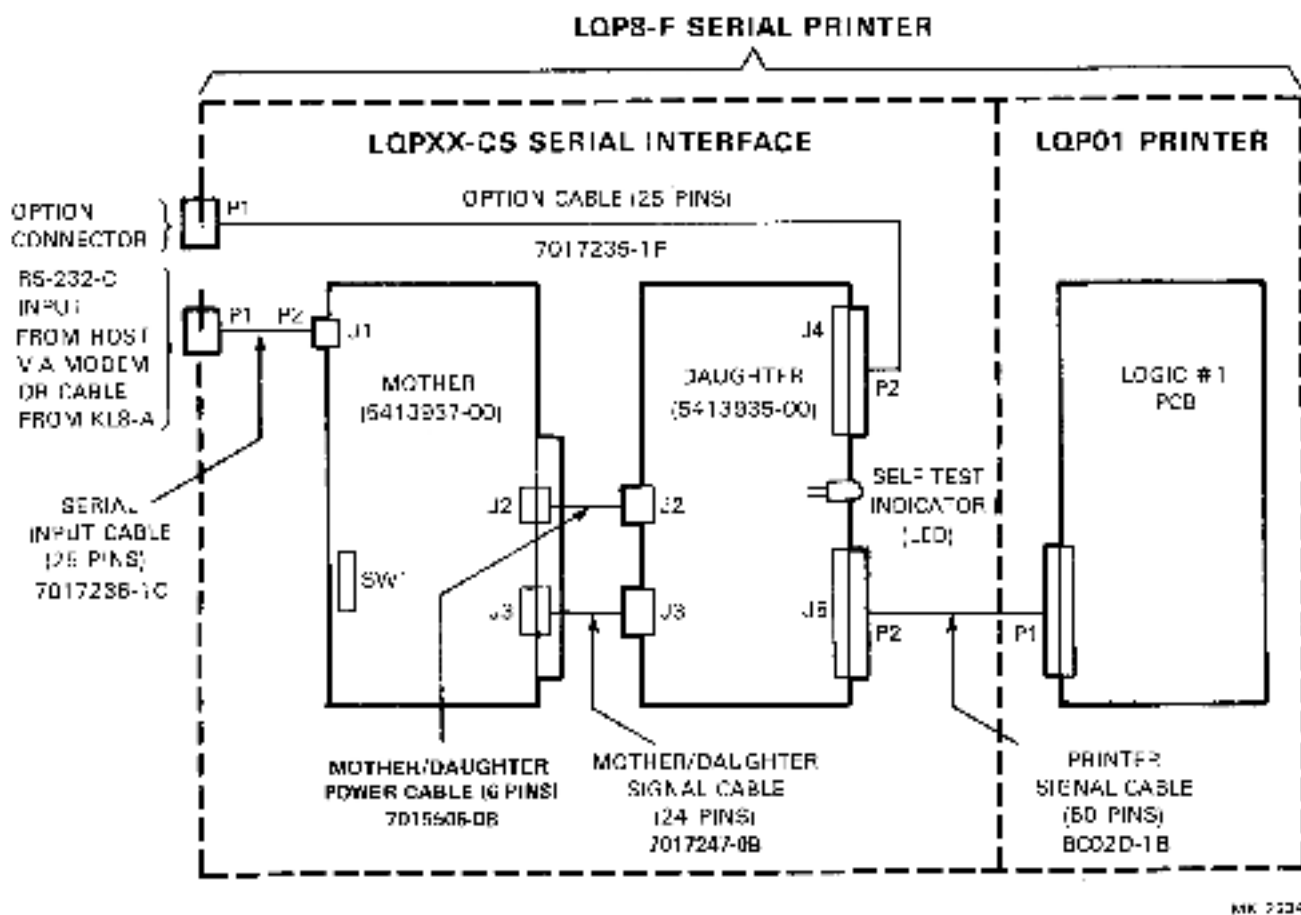

Figure F-2 LQPXX-CS Cable Connection Diagram

### F.2.3 General Specifications

Input Buffer	310 character
Serial I/O Medium	RS-232-C
Serial I/O Format	8 bits, no parity, 2 stop bits
Serial I/O Code	ASCII

Baud Rate	300, 600, 1200, 2400, 4800, or 9600 (switch selectable)
Parallel Output	Compatible with DIGITAL LQP01 printer
Environment	DEC STD 102 Class B
Temperature	15°C to 32°C (59°F to 90°F)
Relative Humidity	10% to 80% (no condensation)
Maximum Wet Bulb Temperature	28°C (82°F)
Minimum Dew Point Temperature	2°C (36°F)
Altitude (Operating)	Sea level to 2.4 km (8000 ft)
Dimensions	Compatible with DIGITAL LQP01 printer
Power Required	+5 V at 1.0 A nominal, 2.0 A maximum +15 V at 3.0 A maximum, 0.074 A nominal -15 V at 0.034 A nominal

#### F.2.4 Applicable Documents

The following documents are relevant to the LQP8-F serial printer:

- *Using the Letter Quality Printer*, AA-J042A-TK
- *Serial Printer Interface Self Test Diagnostics*, AILQAA0
- *Field Maintenance Print Set*, MP00800

#### F.3 PREOPERATIONAL CHECKOUT

A null modem cable (DIGITAL Part No. BC03M) is plugged into the EIA connector outside the printer, and the other end is plugged into the appropriate connection on the system.

The printer is tested by using the AILQAA0 diagnostic and the system software to ensure that the printer is operating correctly.

Either WPS-8 or WS200 software supports the LQP8-F serial printer.

Verify that the switch settings discussed in the following paragraph are correct.

#### Mother Board Switch Settings

Refer to Figure F-3 and verify that the SW1 switches are set to the correct baud rate and that the self-test switch (SW1-2) is in the correct position. Each baud rate is selected with a single switch on and all others off (that is, only one baud rate switch should be on). Printers are normally run with switch SW1-2 off.

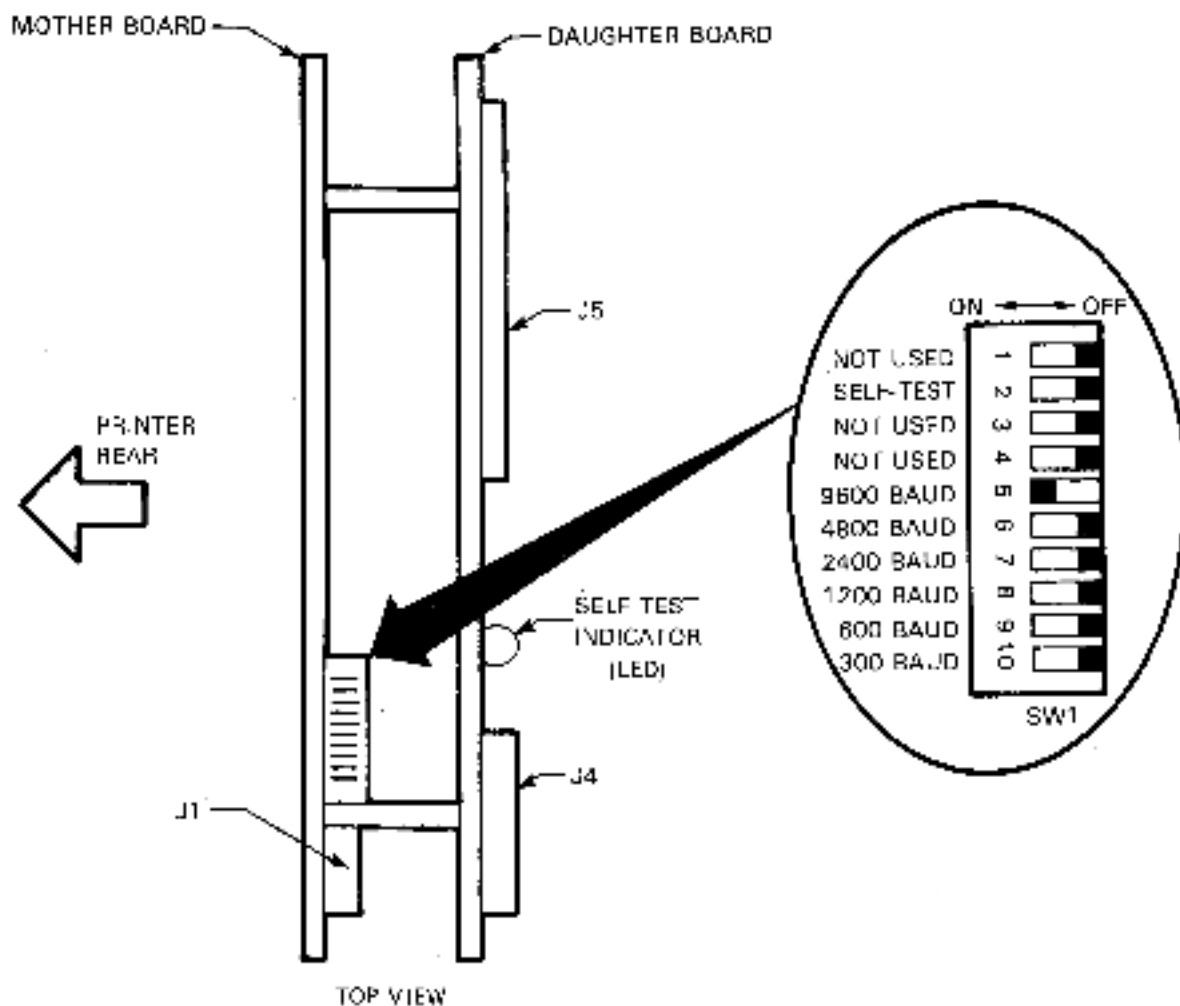

MK 2236

Figure F-3 Mother Board Switch Settings

#### F.4 FUNCTIONAL DESCRIPTION

The LQPXX-CS is designed to receive serial input data on the mother module. The input is decoded and sent to the daughter module. The daughter module converts the decoded input to parallel information to feed the printer.

Status information from the printer is sent to the interface, encoded, and passed to the system hardware.

Figure F 4 provides a functional block diagram of the LQPXX-CS interface.

#### F.5 SERVICING

##### F.5.1 General

This section describes the Field Service maintenance procedures for the LQPXX-CS serial printer interface.

The LQPXX-CS serial printer interface requires no preventive maintenance and no alignment and adjustment.

### F.5.2 Maintenance Plan

The corrective maintenance philosophy is FRU (field replaceable unit) swap (that is, modules and cables).

The mother and daughter modules can be quickly separated from each other because of the use of snap-in fasteners. All cables are attached to the interface with connectors to allow easy module removal. Setting the self-test switch (see Figure F-3, switch SW1-2) to ON allows the power on/start-up internal test and the stand-alone printer test to run. A passed or failed condition is indicated by the self-test (LED) indicator located on the daughter board.

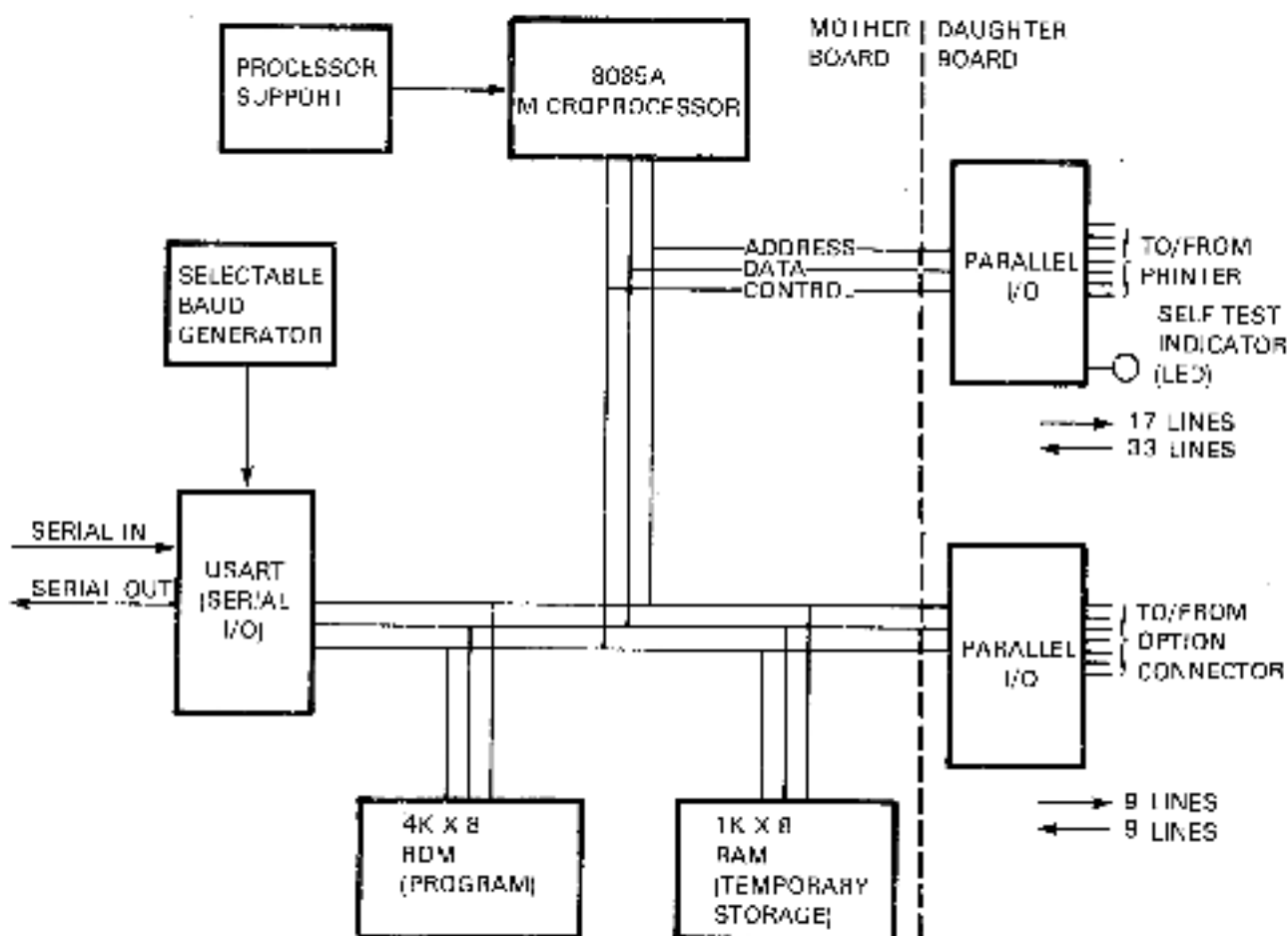

W.K. 2226

Figure F-4 Functional Block Diagram

### F.5.3 FRU Spares and Tools

Table F-2 lists the recommended spares for FRU maintenance.

#### NOTE

No special tools and test equipment are required.

**Table F-2 Recommended FRU Spares and Tools for the LQPXX-CS**

Name	DIGITAL Part No.
Mother Module	5413937-00
Daughter Module	5413935-00
Mother/Daughter Power Cable	7015806-0B
Mother/Daughter Signal Cable	7017247-0B
Printer Signal Cable	BC0210-1B
Serial Input Cable	7017236-1C
Option Control Cable	7017235-1F
Support/Spacer Circuit Board	9009213-02

**F.5.4 Diagnostics**

Use the A11QAA0 diagnostic software for WS78, WS80, and WS200 systems, which is available on discrete for testing the LQP8-I serial printer. Procedures for running these diagnostics are not provided in this appendix.

A11QAA0 is the diagnostic name. Hard copy listing is AC-F775A MA. Microfiche listing is AH-F775A-MA.

**F.5.5 Troubleshooting**

The LQP8-I will run as a stand-alone unit by setting the self-test switch (Figure F-3, switch SW 1-2) to the ON position before power up; this allows the microprocessor to be loaded with and start running the self-test program at power-up time. The self-test program first runs an internal interface test and then runs a continuous printer exerciser test. At power-up time the GO/NO GO LED (a self-test indicator located on the daughter board) will light three times over a period of 2 seconds and will extinguish after successful completion of the internal interface test. Then the printer exerciser program will print a 9.6 inch long line of characters from left to right and a 9.6 inch long line of characters from right to left. It will continuously repeat the sequence (see Figure F-5) until power is removed.

There are two troubleshooting aids:

- The built-in self-test.
- The LQP Printer Diagnostic.

Failures can be determined by visual inspection of the GO/NO GO LED and the printer output.

Repair consists of replacing the FRU that has failed.

The system hardware connection can be tested separately from the LQP8-I. This is accomplished by attaching an EIA loop-back connector to the cable attached to the system and then running a loop-back test on the KL8-A.

**Self-Test Procedure**

With the printer top covers removed and the self-test switch (SW1-2, see Figure F-3) set to ON, perform the following steps:

1. Load 14 inch wide paper (or 8 1/2 inch wide paper installed sideways) into the printer.

2. Apply power to the printer and observe that the self-test indicator (Figure F-3) lights three times over a period of 2 seconds and then goes off. This lighting sequence indicates a successful internal test of both LQPXX-C5 interface modules. If the self-test indicator fails to light, or lights and fails to go out, replace the failing interface module.
3. Next, the printer functional test starts and continues printing full character set lines, as shown in Figure F-5. Note that there is a 1-second pause at the end of each line to allow for the ribbon to drop.

**NOTE**

**To temporarily stop the printing, press the PAUSE push button. Press it again to resume printing.**

4. To terminate the self-test, switch off ac power to the printer and then set the self-test switch (Figure F-3) to OFF.

### F.5.6 Module Removal and Replacement

To remove the mother/daughter module pair, remove the printer top covers and remove the PCB clamp. Then perform the following steps:

1. Remove the serial input cable P2 at the mother board connector J1 (see Figure F-1).
2. Remove the option cable P3 at the daughter board J4.
3. Remove the printer signal cable P2 at the daughter board J5.
4. Remove the mother/daughter module pair from the backplane.

Replacement procedures are the reverse of removal procedures.

### F.6 INTERFACE WIRING DETAILS

The serial input cable (RS-232-C Connector J1 DB25S Connector) consists of the following pins:

Pin	Function	Pin	Function
1	Printer chassis ground	14	Not used
2	Transmitted data	15	Not used
3	Received data	16	Not used
4	Not used	17	Not used
5	Not used	18	Not used
6	Not used	19	Not used
7	Signal ground	20	Data terminal ready
8	Not used	21	Not used
9	Not used	22	Not used
10	Not used	23	Not used
11	Not used	24	Not used
12	Not used	25	Not used
13	Not used		

```

i#321()#+, -/0123456789:;<=>?@ABCDEFGHIJKLMNQRSTUWXYZ[\]^_`{|}~"#$%&'()*+,-./:;
i#322()#+, -/0123456789:;<=>?@ABCDEFGHIJKLMNQRSTUWXYZ[\]^_`{|}~"#$%&'()*+,-./:;
i#323()#+, -/0123456789:;<=>?@ABCDEFGHIJKLMNQRSTUWXYZ[\]^_`{|}~"#$%&'()*+,-./:;
i#324()#+, -/0123456789:;<=>?@ABCDEFGHIJKLMNQRSTUWXYZ[\]^_`{|}~"#$%&'()*+,-./:;
i#325()#+, -/0123456789:;<=>?@ABCDEFGHIJKLMNQRSTUWXYZ[\]^_`{|}~"#$%&'()*+,-./:;
i#326()#+, -/0123456789:;<=>?@ABCDEFGHIJKLMNQRSTUWXYZ[\]^_`{|}~"#$%&'()*+,-./:;
i#327()#+, -/0123456789:;<=>?@ABCDEFGHIJKLMNQRSTUWXYZ[\]^_`{|}~"#$%&'()*+,-./:;
i#328()#+, -/0123456789:;<=>?@ABCDEFGHIJKLMNQRSTUWXYZ[\]^_`{|}~"#$%&'()*+,-./:;
i#329()#+, -/0123456789:;<=>?@ABCDEFGHIJKLMNQRSTUWXYZ[\]^_`{|}~"#$%&'()*+,-./:;
i#330()#+, -/0123456789:;<=>?@ABCDEFGHIJKLMNQRSTUWXYZ[\]^_`{|}~"#$%&'()*+,-./:;
i#331()#+, -/0123456789:;<=>?@ABCDEFGHIJKLMNQRSTUWXYZ[\]^_`{|}~"#$%&'()*+,-./:;
i#332()#+, -/0123456789:;<=>?@ABCDEFGHIJKLMNQRSTUWXYZ[\]^_`{|}~"#$%&'()*+,-./:;
i#333()#+, -/0123456789:;<=>?@ABCDEFGHIJKLMNQRSTUWXYZ[\]^_`{|}~"#$%&'()*+,-./:;
i#334()#+, -/0123456789:;<=>?@ABCDEFGHIJKLMNQRSTUWXYZ[\]^_`{|}~"#$%&'()*+,-./:;
i#335()#+, -/0123456789:;<=>?@ABCDEFGHIJKLMNQRSTUWXYZ[\]^_`{|}~"#$%&'()*+,-./:;
i#336()#+, -/0123456789:;<=>?@ABCDEFGHIJKLMNQRSTUWXYZ[\]^_`{|}~"#$%&'()*+,-./:;
i#337()#+, -/0123456789:;<=>?@ABCDEFGHIJKLMNQRSTUWXYZ[\]^_`{|}~"#$%&'()*+,-./:;
i#338()#+, -/0123456789:;<=>?@ABCDEFGHIJKLMNQRSTUWXYZ[\]^_`{|}~"#$%&'()*+,-./:;
i#339()#+, -/0123456789:;<=>?@ABCDEFGHIJKLMNQRSTUWXYZ[\]^_`{|}~"#$%&'()*+,-./:;
i#340()#+, -/0123456789:;<=>?@ABCDEFGHIJKLMNQRSTUWXYZ[\]^_`{|}~"#$%&'()*+,-./:;

```

NOTE:  
 A 1 SECOND PAUSE  
 HERE AFTER EACH  
 LINE IS PRINTED.

24.38 CM (9.6 INCHES)

Figure F-5 Self Test Functional Test Printout

MM 2784



Your comments and suggestions will help us in our continuous effort to improve the quality and usefulness of our publications.

What is your general reaction to this manual? In your judgement is it complete, accurate, well organized, well written, etc? Is it easy to use? \_\_\_\_\_  
\_\_\_\_\_  
\_\_\_\_\_

What features are most useful? \_\_\_\_\_  
\_\_\_\_\_  
\_\_\_\_\_

What faults or errors have you found in the manual? \_\_\_\_\_  
\_\_\_\_\_  
\_\_\_\_\_

Does this manual satisfy the need you think it was intended to satisfy? \_\_\_\_\_

Does it satisfy *your* needs? \_\_\_\_\_ Why? \_\_\_\_\_  
\_\_\_\_\_  
\_\_\_\_\_

- Please send me the current copy of the *Technical Documentation Catalog*, which contains information on the remainder of DIGITAL's technical documentation.

Name \_\_\_\_\_ Street \_\_\_\_\_  
Title \_\_\_\_\_ City \_\_\_\_\_  
Company \_\_\_\_\_ State/Country \_\_\_\_\_  
Department \_\_\_\_\_ Zip \_\_\_\_\_

Additional copies of this document are available from:

Digital Equipment Corporation  
444 Whitney Street  
Northboro, MA 01532

Attention: Communications Services (NR2/M15)  
Customer Services Section

Order No.     EK-OLQP8-TM-003

-----  
Fold Here  
-----

-----  
Do Not Tear - Fold Here and Staple  
-----

**digital**



No Postage  
Necessary  
if Mailed in the  
United States

**BUSINESS REPLY MAIL**

POST OFFICE PERMIT NO. 58 MERRIMACK, NH

POSTAGE WILL BE PAID BY ADDRESSEE

Digital Equipment Corporation  
Educational Services Development & Publishing  
Continental Blvd. (MK1/2M25)  
Merrimack, N.H. 03054





**digital**

digital equipment corporation