

**LSI-11, PDP-11/03
user's manual**

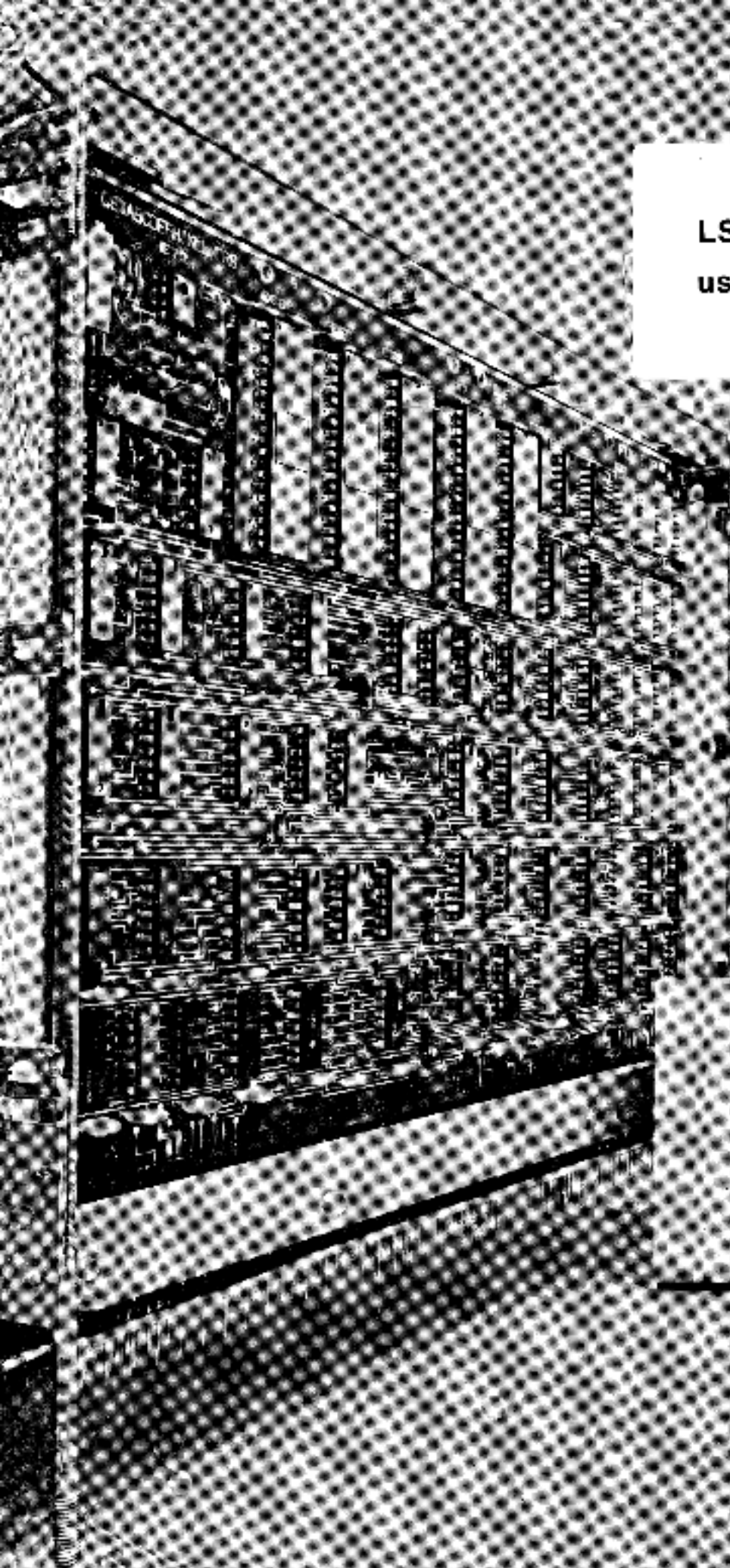

PARSONS CORPORATION

11/76

**LSI-11, PDP-11/03
user's manual**

1st Edition, September 1975
2nd Printing (Rev), November 1975
3rd Printing (Rev), May 1976

Copyright © 1975, 1976 by Digital Equipment Corporation

The material in this manual is for informational purposes and is subject to change without notice.

Digital Equipment Corporation assumes no responsibility for any errors which may appear in this manual.

Printed in U.S.A.

The following are trademarks of Digital Equipment Corporation, Maynard, Massachusetts:

DEC	DECtape	PDP
DECCOMM	DECUS	RSTS
DECsystem-10	DIGITAL	TYPESET-8
DECsystem-20	MASSBUS	TYPESET-11
		UNIBUS

CONTENTS

		Page
CHAPTER 1	INTRODUCTION	
1.1	GENERAL	1-1
1.2	SCOPE	1-1
1.3	REFERENCES	1-1
CHAPTER 2	LSI-11 SYSTEM OVERVIEW	
2.1	GENERAL	2-1
2.2	SYSTEM CONFIGURATIONS	2-1
2.3	LSI-11 MICROCOMPUTER	2-1
2.4	I/O BUS CONCEPT	2-2
2.5	MEMORY OPTIONS	2-3
2.6	PERIPHERAL INTERFACE OPTIONS	2-3
2.7	BACKPLANE, POWER SUPPLY, AND HARDWARE OPTIONS	2-3
2.8	POWER REQUIREMENTS	2-4
2.9	GENERAL SPECIFICATIONS	2-4
CHAPTER 3	THE LSI-11 BUS	
3.1	CHOOSING AN I/O TRANSFER TYPE	3-1
3.2	DEVICE PRIORITY	3-1
3.3	MODULE CONTACT FINGER IDENTIFICATION	3-2
3.4	BUS SIGNALS	3-4
3.5	BUS CYCLES	3-7
3.5.1	General	3-7
3.5.2	Input Operations	3-7
3.5.3	Output Operations	3-8
3.6	DMA OPERATIONS	3-11
3.7	INTERRUPTS	3-12
3.8	BUS INITIALIZATION	3-12
3.9	POWER-UP/POWER-DOWN SEQUENCE	3-12
3.10	HALT MODE	3-13
3.11	MEMORY REFRESH	3-13
3.12	BUS SPECIFICATIONS	3-14
3.13	BUS CONFIGURATIONS	3-14
3.14	BUS SIGNAL TIMING	3-15
CHAPTER 4	LSI-11 MODULE DESCRIPTIONS	
4.1	GENERAL	4-1
4.2	KD11-F MICROCOMPUTER	4-2
4.2.1	General	4-2
4.2.2	Basic Microcomputer Functions	4-3
4.2.2.1	Microprocessor Chip Set	4-3
4.2.2.2	Clock Pulse Generator	4-3
4.2.2.3	Bus Interface and Data/Address Distribution	4-4
4.2.2.4	Bus I/O Control Signal Logic	4-5
4.2.2.5	Bank 7 Decoder	4-7
4.2.2.6	Interrupt Control and Reset Logic	4-7
4.2.2.7	Special Control Functions	4-9
4.2.2.8	Bus Arbitration Logic	4-10

CONTENTS (Cont)

		Page
4.2.3	KD11-F Resident Memory	4-13
4.2.4	DC-DC Power Inverter	4-14
4.3	MMV11-A 4K BY 16-BIT CORE MEMORY	4-14
4.3.1	General	4-14
4.3.2	Functional Description	4-15
4.3.2.1	Introduction	4-15
4.3.2.2	Core Addressing	4-17
4.3.2.3	Read/Write Data Path	4-18
4.3.2.4	Timing and Control	4-20
4.3.2.5	DC Protection and Vcc Switch	4-23
4.3.2.6	DC-DC Inverter	4-24
4.4	MRV11-A 4K BY 16-BIT READ-ONLY MEMORY	4-24
4.4.1	General	4-24
4.4.2	Functional Description	4-24
4.4.2.1	General	4-24
4.4.2.2	Addressing	4-26
4.4.2.3	Data Read Operation	4-26
4.5	MS11-B 4K BY 16-BIT SEMICONDUCTOR READ/WRITE MEMORY	4-27
4.5.1	General	4-27
4.5.2	Functional Description	4-27
4.6	<i>This section was deleted</i>	
4.7	DLV11 SERIAL LINE UNIT	4-29
4.7.1	General	4-29
4.7.2	Functional Description	4-32
4.7.2.1	General	4-32
4.7.2.2	UART Operation	4-32
4.7.2.3	Baud Rate Generator	4-32
4.7.2.4	Bus Drivers and Receivers	4-32
4.7.2.5	Address Decoding	4-32
4.7.2.6	Function Decoding and Control	4-32
4.7.2.7	Interface Control Logic	4-32
4.7.2.8	CSR Selection and Gating	4-34
4.7.2.9	Break Logic	4-34
4.7.2.10	Reader Run Logic	4-34
4.7.2.11	EIA Interface Circuits	4-34
4.7.2.12	20 mA Loop Current Interface	4-35
4.7.2.13	12 V Inverter	4-35
4.8	DRV11 PARALLEL LINE UNIT	4-35
4.8.1	General	4-35
4.8.2	Functional Description	4-35
4.8.2.1	General	4-35
4.8.2.2	Addressing	4-35
4.8.2.3	Function Selection	4-35
4.8.2.4	Read Data Multiplexer	4-38
4.8.2.5	DRCSR Functions	4-38
4.8.2.6	DRINBUF Input Data Transfer	4-38
4.8.2.7	DROUTBUF Output Data Transfer	4-38

CONTENTS (Cont)

		Page
4.8.2.8	Interrupts	4-38
4.8.2.9	Maintenance Mode	4-39
4.8.2.10	Initialization	4-39
4.9	H780 POWER SUPPLY	4-39
4.9.1	General	4-39
4.9.2	Specifications	4-40
4.9.3	Functional Description	4-40
4.9.3.1	General	4-40
4.9.3.2	Coregulated Voltage and Local Power	4-40
4.9.3.3	Basic Regulator Circuit	4-42
4.9.3.4	Overload and Short-Circuit Protection	4-43
4.9.3.5	Crowbar Circuits	4-44
4.9.3.6	Logic Signal Generation	4-44
4.9.4	H780 Connections	4-48
CHAPTER 5	USING KD11-F and KD11-J PROCESSORS	
5.1	GENERAL	5-1
5.2	JUMPER-SELECTED FEATURES	5-1
5.2.1	General	5-1
5.2.2	Memory Refresh	5-1
5.2.3	Line Time Clock	5-2
5.2.4	Power-Up Mode Selection	5-2
5.2.5	Resident Memory 4K Address Selection	5-3
5.3	INSTALLATION	5-4
5.4	USING THE LSI-11 MICROCOMPUTER	5-4
5.4.1	General	5-4
5.4.2	Interrupt and Trap Priority	5-4
5.4.3	Half Mode	5-4
5.5	INITIALIZATION AND POWER FAIL	5-4
CHAPTER 6	LSI-11 INTERFACE MODULES	
6.1	GENERAL	6-1
6.2	DLV11 SERIAL LINE UNIT	6-1
6.2.1	General	6-1
6.2.2	Jumper-Selected Addressing, Vectors, and Module Operations	6-1
6.2.2.1	Locations	6-1
6.2.2.2	Addressing	6-1
6.2.2.3	Vectors	6-3
6.2.2.4	UAR/T Operation	6-3
6.2.2.5	Baud Rate Selection	6-3
6.2.2.6	EIA Interface	6-3
6.2.2.7	20 mA Current Loop Interface	6-3
6.2.2.8	Framing Error Halt	6-4
6.2.3	Installation	6-4
6.2.4	Interfacing with 20 mA Current Loop Devices	6-4
6.2.5	Interfacing with EIA-Compatible Devices	6-5
6.2.6	Programming	6-5
6.2.6.1	Addressing	6-5

CONTENTS (Cont)

		Page
6.2.6.2	Interrupt Vectors	6-6
6.2.6.3	Word Formats	6-6
6.2.7	Console Device	6-6
6.3	DRV11 PARALLEL LINE UNIT	6-6
6.3.1	General	6-6
6.3.2	Jumper-Selected Addressing and Vectors	6-6
6.3.2.1	Locations	6-9
6.3.2.2	Addressing	6-9
6.3.2.3	Vectors	6-10
6.3.3	Installation	6-10
6.3.4	Interfacing to the User's Device	6-11
6.3.4.1	General	6-11
6.3.4.2	Output Data Interface	6-11
6.3.4.3	Input Data Interface	6-13
6.3.4.4	Request Flags	6-13
6.3.4.5	Initialization	6-13
6.3.4.6	NEW DATA READY and DATA TRANSMITTED Pulse Width Modification	6-13
6.3.4.7	BCO&R Maintenance Cable	6-13
6.3.5	Programming	6-13
6.3.5.1	Addressing	6-13
6.3.5.2	Interrupt Vectors	6-14
6.3.5.3	Word Formats	6-14
CHAPTER 7	USING MSV11-B READ/WRITE MEMORY MODULES	
7.1	GENERAL	7-1
7.2	MSV11-B JUMPERS	7-1
7.2.1	Addressing	7-1
7.2.2	Reply to Refresh	7-1
7.3	MSV11-B BUS RESTRICTION	7-1
CHAPTER 8	USING MMV11-A CORE MEMORY	
8.1	GENERAL	8-1
8.2	SWITCH-SELECTED ADDRESSING	8-1
8.2.1	General	8-1
8.3	BUS RESTRICTIONS	8-2
CHAPTER 9	USING MRV11-A READ-ONLY MEMORY	
9.1	GENERAL	9-1
9.2	JUMPER-SELECTED ADDRESSING AND CHIP TYPE	9-3
9.2.1	General	9-3
9.2.2	Chip Type Selection	9-3
9.2.3	Addressing and Reply	9-3
9.3	PROGRAMMING PROM AND ROM CHIPS	9-4
9.4	PROGRAMMING RESTRICTIONS	9-5
9.5	TIMING AND BUS RESTRICTION	9-5

CONTENTS (Cont)

		Page
CHAPTER 10	USER-DESIGNED INTERFACES	
10.1	GENERAL	10-1
10.2	BUS RECEIVER AND DRIVER CIRCUITS	10-1
10.3	PROGRAMMED INTERFACE	10-2
10.4	INTERRUPT LOGIC	10-5
10.5	DMA INTERFACE LOGIC	10-5
CHAPTER 11	SYSTEM CONFIGURATION AND INSTALLATION	
11.1	GENERAL	11-1
11.2	CONFIGURATION CHECKLIST	11-1
11.3	DEVICE PRIORITY	11-2
11.3.1	General	11-2
11.3.2	Priority Selection Using the H9270 Backplane	11-2
11.3.3	H9270 Backplane/MMV11 A Configuration	11-2
11.4	MODULE INSERTION AND REMOVAL	11-3
11.5	DC CABLING	11-4
11.6	PDP-11/03 INSTALLATION PROCEDURE	11-4
11.6.1	Packaging and Mounting	11-4
11.6.2	Power Requirements	11-5
11.6.3	Environmental Requirements	11-5
11.7	LSI-11 SYSTEM INSTALLATION	11-5
11.7.1	General	11-5
11.7.2	Mounting the H9270 Backplane	11-5
11.7.3	DC Power Connections	11-5
11.7.3.1	Voltage and Current Requirements	11-5
11.7.3.2	H9270 Backplane Power Connections	11-7
11.7.4	H9270 Backplane Ground Connection	11-8
11.7.5	Environmental Requirements	11-8
11.7.6	Externally Generated Bus Signals	11-8
11.7.6.1	General	11-8
11.7.6.2	BDCOK D and BPOK H	11-9
11.7.6.3	BTVN L Signal	11-9
11.7.6.4	BHALT L Signal	11-10
11.8	SYSTEM OPERATION	11-10
11.8.1	General	11-10
11.8.2	PDP-11/03 Power-On	11-10
11.8.3	LSI-11 Power-On	11-12
11.8.4	ASCII Character Console Printout Program	11-12
11.9	PAPER TAPE SYSTEM OPERATION	11-12
11.9.1	General	11-12
11.9.2	References	11-12
11.9.3	Loading the Absolute Loader	11-13
11.9.4	Loading Program Tapes	11-14
11.9.4.1	General	11-14
11.9.4.2	Normal Loading Procedure	11-14
11.9.4.3	Relocated Loading Procedure	11-14
11.9.4.4	Self-Starting Programs	11-15
11.9.5	Program Starting and Execution	11-15

CONTENTS (Cont)

	Page
11.10	RT-11 SYSTEM OPERATION 11-15
11.10.1	General 11-15
11.10.2	Using the RX01 11-16
11.10.3	RXV11 Bootstrap 11-16
11.10.3.1	General 11-16
11.10.3.2	Booting the System Using the REV11-A or REV11-C 11-16
11.10.3.3	Booting the System Via the Console Device 11-16
11.10.4	Using the RT-11 11-17
CHAPTER 12	PERIPHERALS
APPENDIX A	MEMORY MAP
APPENDIX B	LSI-11 BUS PIN ASSIGNMENTS
APPENDIX C	7-BIT ASCII CODE
APPENDIX D	SUMMARY OF LSI-11 INSTRUCTIONS
APPENDIX E	I19270 BACKPLANE CONFIGURATIONS
APPENDIX F	BUS INTERFACE I.C. PINS
APPENDIX G	LSI-11 BUS ACCESSORY OPTIONS INSTALLATION AND OPERATION
APPENDIX H	DLV11 I/O JUMPER CONFIGURATIONS

ILLUSTRATIONS

Figure No.	Title	Page
3-1	Module Contact Finger Identification	3-2
3-2	Quad Module Contact Finger Identification	3-3
3-3	LSI-11, PDP-11/03 Backplane Module Pin Identification	3-3
3-4	DATI Bus Cycle	3-8
3-5	DATIO or DATIOB Bus Cycle	3-9
3-6	DATO or DATOB Bus Cycle	3-10
3-7	DMA Request/Grant Sequence	3-11
3-8	Interrupt Request/Acknowledge Sequence	3-13
3-9	Bus Line Terminations	3-14
3-10	Minimum Configurations	3-14
3-11	Intermediate Configuration	3-15
3-12	Maximum Configuration	3-15
3-13	DATI Bus Cycle Timing	3-16
3-14	DATO or DATOB Bus Cycle Timing	3-17
3-15	DATIO Bus Cycle Timing	3-18
3-16	Interrupt Transaction Timing	3-19
3-17	DMA Request/Grant Timing	3-20
3-18	Power-Up/Power-Down Timing	3-20
4-1	KD11-F Microcomputer Logic Block Diagram	4-2
4-2	Clock Pulse Generator	4-3
4-3	LSI-11 Bus Loading and Driver/Receiver Interface	4-4
4-4	EDAL L Logic	4-4
4-5	Bus I/O Control Signal Logic	4-6
4-6	Bank 7 Decoder	4-7
4-7	Interrupt Control and Reset Logic	4-8
4-8	Special Control Functions	4-10
4-9	Bus Arbitration Logic	4-11
4-10	DMA Grant Sequence	4-11
4-11	KD11-F Resident Memory	4-12
4-12	MMV11-A Core Memory Option	4-14
4-13	MMV11-A Logic Block Diagram	4-16
4-14	MMV11-A Core Addressing	4-17
4-15	MMV11-A Read/Write Bit Data Path	4-19
4-16	MMV11-A Timing and Control Circuits	4-21
4-17	Read-Restore Memory Cycle Timing	4-22
4-18	Read-Modify-Write Memory Cycle Timing	4-22
4-19	DC Protection and Vcc Switch Circuits	4-23
4-20	DC-DC Inverter Circuit	4-24
4-21	MRV11-A Logic Block Diagram	4-25
4-22	512 by 4-Bit Chip-Jumper Configuration	4-26
4-23	256 by 4-Bit Chip-Jumper Configuration	4-27
4-24	MSV11-B Logic Block Diagram	4-28
4-25	<i>This figure was deleted</i>	
4-26	DI V11 Logic Block Diagram	4-33
4-27	DRV11 Logic Block Diagram	4-36
4-28	H750 Power Supply Block Diagram	4-41
4-29	Unregulated Voltage and Local DC Power	4-41
4-30	Basic Regulator Circuit	4-42
4-31	Overload and Short-Circuit Protection	4-43

ILLUSTRATIONS (Cont)

Figure No.	Title	Page
4-32	Crowbar Circuit	4-44
4-33	Logic Signal Generation	4-45
4-34	Power-Up/Power-Down Sequence	4-46
4-35	DC ON/OFF Circuit Timing	4-47
4-36	I1780 Connections	4-48
5-1	Jumper Locations	5-1
5-2	Mode 0 Power-Up Sequence	5-3
5-3	Mode 2 Power-Up Sequence	5-3
6-1	DLV11 Serial Line Unit	6-1
6-2	DLV11 Jumper Locations	6-2
6-3	DLV11 Addresses	6-2
6-4	DLV11 Interrupt Vectors	6-3
6-5	Active 20 mA Current Loop Interface	6-4
6-6	Passive 20 mA Loop Jumper Configuration	6-5
6-7	EIA Interface	6-6
6-8	DLV11 Word Formats	6-8
6-9	DRV11 Parallel Line Unit	6-8
6-10	DRV11 Jumper Locations	6-9
6-11	DRV11 Device Address	6-9
6-12	DRV11 Vector Address	6-10
6-13	J1 or J2 Connector Pin Locations	6-10
6-14	DRV11 Word Formats	6-14
7-1	MSV11-B 4K by 16-Bit Read/Write Memory	7-1
7-2	MSV11-B Jumper Locations	7-2
7-3	MSV11-B Address Format/Jumpers	7-2
8-1	MMV11-A 4K by 16-Bit Core Memory	8-1
8-2	Bank Address Switch Locations	8-2
8-3	MMV11-A Addressing	8-2
9-1	MRV11-A Read-Only Memory	9-1
9-2	MRV11-A Jumper Locations	9-2
9-3	MRV11-A Address Word Formats	9-3
9-4	PROM/ROM Chip Pin Addressing	9-4
10-1	Bus Driver and Receiver Equivalent Circuits	10-1
10-2	Typical Bus Driver Circuit	10-1
10-3	Programmed I/O Interface	10-3
10-4	Dual Interrupt Interface	10-4
10-5	DMA Arbitration Logic	10-6
11-1	Typical Configuration ILS-11 Backplane — Processor and Option Locations	11-2
11-2	H9270 Backplane/MMV11-A Core	11-3
11-3	Module Installation in the H9270 Backplane	11-3
11-4	H9270 Backplane	11-4
11-5	PDP-11/03 Cabinet Mounting	11-5
11-6	H9270 Backplane Mounting	11-6
11-7	H9270 Side Mounting	11-6
11-8	H9270 Rear Mounting	11-6
11-9	H9270 Top and Bottom Mounting	11-6

ILLUSTRATIONS (Cont)

Figure No.	Title	Page
11-10	H9270 Backplane Terminal Block	11-7
11-11	H9270 Backplane Ground Wire (DOLLITLD)	11-8
11-12	H9270 Backplane Air Flow	11-8
11-13	H9270 Backplane Printed Circuit Board	11-8
11-14	Power-Up Sequence	11-9
11-15	Power-Down Sequence	11-9
11-16	HDCCOK II Signal Routing Diagram	11-10
11-17	BI-VNT L Signal	11-10
11-18	Sample Console Printout	11-13
12-1	Direct 20 mA Current Loop Interface	12-1
12-2	Telephone Line Interface Via Data Sets	12-1
12-3	Telephone Line Interface Via Acoustic Couplers	12-1

TABLES

Table No.	Title	Page
2-1	LSI-11 Modules Power Requirements	2-4
3-1	Backplane Pin Assignments	3-4
4-1	LSI-11 Modules	4-1
4-2	DLV11 Function Decoding	4-34
4-3	DRV11 Device Function Decoding	4-37
5-1	Summary of KD11 Jumpers	5-1
5-2	KD11 Factory Jumper Configuration	5-1
5-3	Power-Up Modes	5-2
6-1	Band Rate Selection	6-3
6-2	Word Formats	6-7
6-3	DRV11 Input and Output Signal Pins	6-11
6-4	BC11K Signal Cable Connections	6-12
6-5	BC08R Maintenance Cable Signal Connections	6-14
6-6	Word Formats	6-15
9-1	MRV11-A Chips	9-1
9-2	PROM/ROM Chip Addressing Data	9-4
9-3	Data Pin Assignments	9-4
10-1	LSI-11 Bus Driver and Receiver Characteristics	10-1
11-1	PDP-11/03 Input Power Electrical Specifications	11-4
11-2	H9270 Backplane Standard Power Connections	11-7
11-3	H9270 Backplane Battery Backup Power Connections	11-7
11-4	Console Power-Up Printout (or Display)	11-11
12-1	LSI-11 Peripheral Options	12-3

CHAPTER 1

INTRODUCTION

1.1 GENERAL

This manual contains technical data that will enable LSI-11 and PDP-11/03 microcomputer users to interface and use LSI-11 system components effectively. Before reading the detailed technical content of this manual, the user should become familiar with the basic characteristics of the LSI-11 processor, as described in the *LSI-11, PDP-11/03 Processor Handbook*.

1.2 SCOPE

This manual contains hardware descriptions and information for using LSI-11 system modules, including system configuration, installation, and interfacing. The manual is organized as follows:

Chapter 1	Introduction
Chapter 2	LSI-11 and PDP-11/03 System Overview
Chapter 3	LSI-11 Bus
Chapter 4	LSI-11 Module Descriptions (including functional theory of operation)

Chapters 5-9	Use of the Various LSI-11 Modules (including jumper configurations, interfacing, and programming information)
Chapter 10	User-Designed Interfaces
Chapter 11	System Configuration and Installation
Chapter 12	Peripherals (including the basic devices available and the required LSI-11 interface module, and cables required for each)

In addition, quick reference information is included in appendixes. This information includes a memory map, LSI-11 bus pin assignments, the 7-bit ASCII code, and a summary of LSI-11 instructions.

1.3 REFERENCES

The *LSI-11, PDP-11/03 Processor Handbook* is a required reference manual for using LSI-11 system components. In addition, standard hardware and interface components are listed and described in the *Hardware/Accessories Catalog* and the *Logic Handbook*.

CHAPTER 2

LSI-11 SYSTEM OVERVIEW

2.1 GENERAL

All LSI-11 and PDP-11/03 systems are configured by selecting various LSI-11 module options which can be installed in a backplane. Although individual system requirements (in which the LSI-11 system functions as a controller and/or data processor) may vary greatly in each application, LSI-11's modular concept allows for efficient use of the microcomputer in a compact, cost-effective, flexible system design. The PDP-11/03 is a packaged LSI-11 system, including a processor, 4K memory, enclosure, H9270 backplane, and H780 power supply.

In general, all LSI-11 and PDP-11/03 systems include the KD11-F or KD11-J microcomputer. The KD11-F is a single 8.5 by 10 inch module that contains the LSI-11 microprocessor and a 4K by 16-bit semiconductor read/write memory. The KD11-J uses the same microcomputer module as the KD11-F; however, it is supplied with the MMV11-A 4K by 16-bit core memory instead of the semiconductor memory. Either type of basic LSI-11 or PDP-11/03 system can be expanded by adding various memory and peripheral device interface options.

2.2 SYSTEM CONFIGURATIONS

LSI-11 systems can be configured using one of three general approaches:

1. *Modules only:* The user purchases only the basic module(s).
2. *Modules and backplane:* The user purchases an LSI-11 subsystem that is easily mounted in a larger system.
3. *LSI-11 system in a box:* The user purchases a PDP-11/03 system. It includes the KD11-J or KD11-F processor and 4K memory, a DLV11 serial line unit, an H9270 backplane, and an H780 power supply installed in a rack-mountable enclosure.

Systems are configured using the basic modules described in the following paragraphs.

2.3 LSI-11 MICROCOMPUTER

This paragraph focuses on the KD11-F (processor and 4K semiconductor memory), which is the basic LSI-11 microcomputer. The KD11-J has all of the basic features of the KD11-F, except for the semiconductor memory; the MMV11-A core memory is included as a separate module.

Each KD11-F features:

- A low-cost, powerful processor for integration into any small- or medium-sized computer system.
- Direct addressing of 32K 16-bit words or 64K 8 bit bytes ($K = 1024$).
- Efficient processing of 8-bit characters without the need to rotate, swap, or mask.
- Asynchronous operation that allows system components to run at their highest possible speed; replacement with faster devices means faster operation without other hardware or software changes.
- A modular component design that provides ease and flexibility in configuring systems.
- Hardware memory stack for handling structured data, subroutines, and interrupts.
- Direct memory access for high data rate devices inherent in the bus architecture.
- Eight general-purpose registers that are available for data storage, pointers, and accumulators. Two are dedicated: SP and PC.
- A bus structure that provides position-dependent priority as peripheral device interfaces are connected to the I/O bus.

- Fast interrupt response without device polling.
- A powerful and convenient set of programming instructions.
- A jumper-selected power-up mode that enables restart through a power-up vector, console Octal Debugging Technique (ODT) microcode subset, or a bootstrap program.
- On-board 4K RAM
- An ODT microprogram that controls all manual entry/display functions previously performed by a control panel through a serial ASCII device (optional) which is capable of transmitting and receiving ODT commands and data.
- Compact size (only 8.5 by 10 in.).

2.4 I/O BUS CONCEPT

The LSI-11 I/O bus is simple, fast, and easy to use as an interface between the LSI-11 microcomputer, memory, and peripheral interface modules. It comprises 17 control lines and a 16-line data/address bus. All modules connected to this bus receive the same interface signals.

Address/data and control lines are open-collector lines which are asserted low. The microcomputer module is capable of driving six device locations along the bus. Peripheral interface or memory modules can be installed in any location along this bus.

Both address and data words (or bytes) are time multiplexed over 16 bus lines. For example, during a programmed data transfer, the LSI-11 microcomputer first asserts an address on the bus for a fixed time. After the address time has been completed, the processor performs either an input or output data transfer; the actual data transfer is asynchronous and requires a response from the addressed device. Bus synchronization and control signals provide this function.

Control signal lines include two daisy-chained grant signals which provide a priority-structured I/O system. The highest priority device is the module electrically closest to the KD11-F (or KD11-J) module. Higher priority devices pass a grant signal to lower priority devices only when not requesting service. (Memory options or devices which do not use these signals must connect the chain.)

The KD11-b contains a memory address register and 4K bank address decoder for its resident memory, which can be assigned to bank 0 or bank 1. Bank 7 is also decoded when addresses ranging from 160000 to

177777 are placed on the bus. These addresses are normally used for addressing nonmemory devices, thus eliminating the need for bank address decoding on peripherals' device interface modules.

The bus provides a vectored interrupt capability for any interface device. Hence, device polling is not required in interrupt processing routines. This results in a considerable savings in processing time when many devices requiring interrupt service are interfaced along the bus. When a device receives an interrupt grant (acknowledge), the KD11-F inputs the device's interrupt vector. The vector points to two addresses which contain a new processor status word and the starting address of the interrupt service routine for the device.

One bus signal line functions as an external event interrupt input to the KD11-F module. This signal line can be connected to a frequency source, such as a line frequency, and used as a line time clock (LTC) interrupt. A jumper on the KD11-F module enables or inhibits this function. When enabled, the device connected to this line has the highest interrupt priority external to the processor. Interrupt vector 100_h is reserved for this function, and an interrupt request via the BEVNT line causes new PC and PS words to be loaded from locations 100_h and 102_h.

Memory refresh of dynamic MOS read/write memory is accomplished by bus signals. Refresh operation is controlled by either the processor module microcode or a user-supplied intelligent DMA device.

The processor can be placed in the Halt mode by asserting one bus signal. This allows peripheral devices or a separate switch to invoke console ODT microcode operation.

Power-up/power-down sequencing is controlled by two bus signals. One signal, when in its true state, implies that primary power is normal. The second signal is in its true state when sufficient dc power is available (and voltages are normal) for normal system logic operation. These signals are produced by circuits contained in the H780 power supply (PDP-11/03 only) or by the user's system (circuits external to the LSI-11 system components).

Direct memory access (DMA) operation is controlled by three bus signals. Logic on the processor module, which is normally bus master, arbitrates DMA requests and grants bus mastership to the highest priority device requesting the bus. Priority is position-dependent through the use of a daisy-chained DMA grant signal.

2.5 MEMORY OPTIONS

Memory options are available for expanding memory to 26K. The basic LSI-11 microcomputer is supplied with read/write memory. KD11-F's memory consists of a 4K dynamic MOS array which is physically located on the processor module. KD11-J's memory is a 4K magnetic core array contained on a separate module; the processor module supplied with the KD11-J contains no semiconductor memory components.

Optional memory modules include:

MRV11-AA — 4K by 16-bit programmable read-only memory on an 8.5 by 5 inch module. Requires one device location on the I/O bus. Can be configured using either 256 by 4-bit or 512 by 4-bit field programmable or masked ROMs for a maximum capacity of 2048 or 4096 16-bit words.

MMV11-A — 4K by 16-bit core memory on an 8.5 by 10 by 0.9 inch module. Requires two device locations on the I/O bus when installed in the backplane (preferred location slots A4-D4). This allows a daughterboard (part of the MMV11-A) to extend slightly beyond the backplane without using additional device locations. If not installed in this location, the MMV11-A requires four device locations because of the additional module thickness (0.9 inch instead of 0.5 inch for all other modules).

MSV11-B — 4K by 16-bit dynamic MOS read/write memory on an 8.5 by 5 inch module. Requires one device location on the I/O bus. Refresh is automatically performed by the KD11-F processor microcode or by an external device.

2.6 PERIPHERAL INTERFACE OPTIONS

Two basic interface modules are used for serial and parallel programmed I/O transfer between the LSI-11 bus and peripheral devices. The DLV11 is a serial line unit used for serial 5- to 8 bit data transfers between a device and the bus. It interfaces either EIA-compatible or 20 mA current loop devices to the bus using optional cables which select the type of serial interface desired. The cables are completely connector and pin-compatible with available modems, DECwriter, DECscope, and teletypewriter options. The DRV11 is a general-purpose parallel line unit interface which is capable of 16-bit input and 16 bit output parallel transfers to/from user devices.

Both interface units contain all required control/status registers, interrupt control logic, and bus interface logic. The user can easily assign unique device and vector addresses for each device by changing the jumpers on each interface module.

Peripheral interface options include:

DLV11 — Serial line unit interface on an 8.5 by 5 inch module. Requires one device location on the bus. Jumpers select crystal-controlled baud rates (50—9600 baud) and serial word format, including number of stop bits, number of data bits, and even, odd, or no parity bit. Optional interface cables include the BC05M, which connects the DLV11 to 20 mA current loop peripheral devices, and the BC05C, which connects the DLV11 to EIA-compatible devices (modems) via a Cinch DB-25P connector.

DRV11 — General-purpose parallel line unit interface on an 8.5 by 5 inch module. Requires one device location on the bus. Two 40-pin connectors are included on the module for user interface application. One is the 16-bit input and the other is the 16-bit output. Optional interface cables are described in the Hardware/Accessories Catalog.

2.7 BACKPLANE, POWER SUPPLY, AND HARDWARE OPTIONS

Backplane, power supply, and hardware options provide a convenient means for configuring the LSI-11 system. An LSI-11 system usually requires an interconnection scheme. The H9270 backplane assembly is the most convenient to use. It is prewired for the LSI-11 I/O bus pinning and can accept one KD11-F microcomputer and up to six LSI-11 interface or memory modules. It includes a card guide assembly which provides mechanical stability for the modules. Power and ground are applied to the backplane via a screw-terminal block.

Power can be obtained from the system in which the LSI-11 subsystem is installed, or the H780 (115 or 230 Vac input) power supply (included in PDP-11/03 systems) can be used. The power supply provides the required regulated voltages for all LSI-11 modules connected to the backplane. In addition, it generates the necessary bus signals to initiate the KD11-F or KD11-J power-up or power-fail processor sequence. Hardware options include standard hardware accessories listed in DIGITAL's Hardware/Accessories Catalog.

2.8 POWER REQUIREMENTS

The power requirements for LSI-11 system modules are given in Table 2-1.

Table 2-1
LSI-11 Modules Power Requirements

Designation	+5 V ± 5%		+12 V ± 3%	
	Typ	Max	Typ	Max
KD11-F	1.8A	2.4A	0.8A	1.6A
KD11-J	6.4A	9.0A	1.2A	1.5A
DLV11	1.0A	1.6A	180 mA	250 mA
DRV11	0.9A	1.6A		
MRV11-AA (with- out memory chips)	0.4A	0.6A		
MKV11 (with 4K memory chips)	2.8A	4.1A		
MSV11-B	0.6A	1.2A	0.3A	0.7A
MMV11-A (standby)	3.0A		0.2A	
MMV11-A (operating)	7.0A		0.6A	

The input power requirements for PDP-11/03 systems are:

PDP-11/03-AA or -BA

100-127 Vac (115 Vac nominal), 50 ± 1 Hz or 60 ± 1 Hz, single phase, 400 W maximum (including options) (190 W typical)

PDP-11/03-AB or -BB

200-254 Vac (230 Vac nominal), 50 ± 1 Hz or 60 ± 1 Hz, single phase, 400 W maximum (including options) (190 W typical)

2.9 GENERAL SPECIFICATIONS

Dimensions (in.)

KD11-J:

10.5 × 8.50 × 0.5

MSV11-B

5 × 8.50 × 0.5

MRV11-AA

5 × 8.50 × 0.5

MMV11-A

10 × 8.50 × 0.9

DLV11

5 × 8.50 × 0.5

DRV11

5 × 8.50 × 0.5

Electrical

Input Logic Levels

TTL Logical Low: 0.8 Vdc max

TTL Logical High: 2.0 Vdc min

Output Logic Levels

TTL Logical Low: 0.4 Vdc max

TTL Logical High: 2.4 Vdc min

Bus Receivers

Logical Low: 1.3 Vdc max, -10 μA max at 0V

Logical High: 1.7 Vdc min, 80 μA max at 2.5V

Bus Drivers

Logical Low: 0.8 Vdc max at 70 nA

Logical High: 25 μA max at 3.5V

Environmental

Ambient Temperature, *PDP-11/03 System*:

Operating: 5° to 40° C

Ambient Temperature, *LSI-11 modules*:

Operating: 5° to 50° C (41° to 122° F)

Nonoperating: -40° to 66° C (-40° to +150° F)

Derate at 6°C/1000 ft. above 8000 ft.

Humidity

10 to 90 percent, noncondensing

Air Flow

200 linear ft./minute min. (modules only)

CHAPTER 3

THE LSI-11 BUS

3.1 CHOOSING AN I/O TRANSFER TYPE

Before interfacing the processor with any peripheral device, the designer must determine the type of I/O transfer that would be best suited for the application: programmed I/O transfers, DMA, or interrupt-driven transfers.

Programmed I/O transfers are executed by single- or double-operand instructions. The instruction can be used to input or output a 16-bit data word or an 8-bit byte. By including the device's address as the effective source or destination address, the user selects the input or output operation. In many instances, the programmer inputs a byte from the device's control/status register (CSR) to determine that the device has input data ready or that it is ready to accept the processor's output data.

DMA transfers are the fastest method of transferring data between memory and a device. They can occur between processor bus cycles and do not alter processor status in any way. Addressing, controlling the size of the data block (number of word or byte transfers in the operation), and type of transfer are under the control of the requesting device. The processor does not modify data being moved in the DMA mode. Thus, blocks of data can be moved at memory speeds via the DMA transfer mode. The processor sets up these conditions before the DMA transfer is executed.

Interrupts allow the processor to continue a programmed operation (sometimes called a background program) without waiting for a device to become ready to transfer data. When the device does become ready, it interrupts the processor's background program execution and causes execution of a device interrupt service routine. After the device's service routine has been executed, the background program is restarted and program execution resumes at the point where it was interrupted.

3.2 DEVICE PRIORITY

Each device has an I/O priority based on its distance from the processor. When two or more devices request interrupt service, the device electrically closer to the microcomputer will receive the interrupt grant (acknowledge). The microcomputer can be inhibited from issuing more grants by setting the processor's priority to 4 in the PS word. Bit 7 in the new PS word should be a 1. If further interrupts are to be serviced, the processor's priority should be 0, and bit 7 in the new PS word should be a 0. Consequently, interrupts can be nested to any level. Factors to consider when assigning device priorities are:

1. *Device Operating Speed* — Data from a fast device is available for only a short period; highest priorities are usually assigned to fast devices to prevent loss of data and to prevent the bus from being tied up by slower devices.
2. *Ease of Data Recovery* — If data from a device is lost, recovery may be automatic, may require manual intervention, or may be impossible to recover; highest priorities are assigned to devices whose data cannot be recovered.
3. *Service Requirements* — Some devices cannot function without help from the processor, while DMA devices can operate independently and require only minimal processor intervention. Devices requiring continual help from the processor for servicing are assigned to lowest priorities to prevent tying up the processor.

Both address and data are multiplexed onto the 16 BDA1 lines. In addition, individual control signals sequence programmed I/O operations, direct memory access (DMA), and processor interrupts. Any bus-

compatible module can be inserted into any bus location and still receive interface signals; however, the module's priority, which is position-dependent along the bus, will change.

3.3 MODULE CONTACT FINGER IDENTIFICATION

DIGITAL plug-in (FLIP CHIP) modules, including LSI-11 modules, all use the same contact finger (pin) identification system. The LSI-11 I/O bus is based on the use of double-height modules. These modules plug into a two-slot bus connector, each containing 36 lines per slot (18 each on component and solder sides of the circuit board). Although the LSI-11 processor module and core memory module are quad-height modules that plug into four connector slots, only two slots (A and B) are used for interface purposes on the processor module. Etched circuit jumpers on the unused portion

of the module maintain continuity of grant signals BIAK1 L to BIAK0 L and BDMG1 L to BDMG0 L. These daisy-chained signals are described later.

Slots, shown as ROW A and ROW B in Figure 3-1, include a numeric identifier for the side of the module. The component side is designated side "1" and the solder side is designated side "2." Letters ranging from A through V (excluding G, I, O, and Q) identify a particular pin on a side of a slot. Hence, a typical pin is designated as:

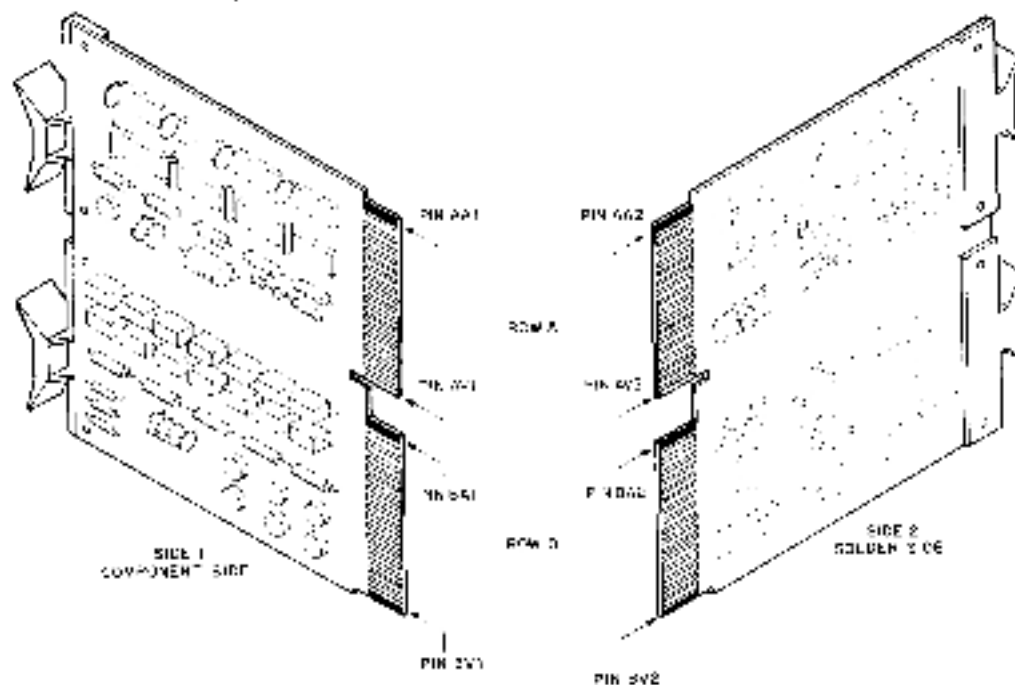
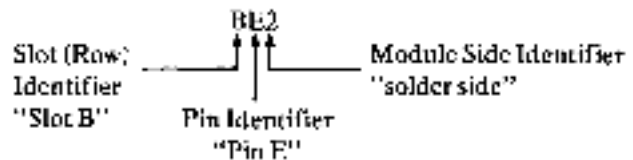

Figure 3-1 Module Contact Finger Identification

Note that the positioning notch between the two rows of pins mates with a protrusion on the connector block for correct module positioning.

Quad-height modules are similarly pin numbered. They are identified in Figure 3-2.

Individual connector pins, viewed from the underside (wiring side) of a backplane, are identified as shown in Figure 3-3. Only the pins for one bus location (two slots) are shown in detail. This pattern of pins is repeated eight times on the H9270 backplane, allowing the user to install one LSI-11 microcomputer module (four slots) and up to six additional two-slot modules.

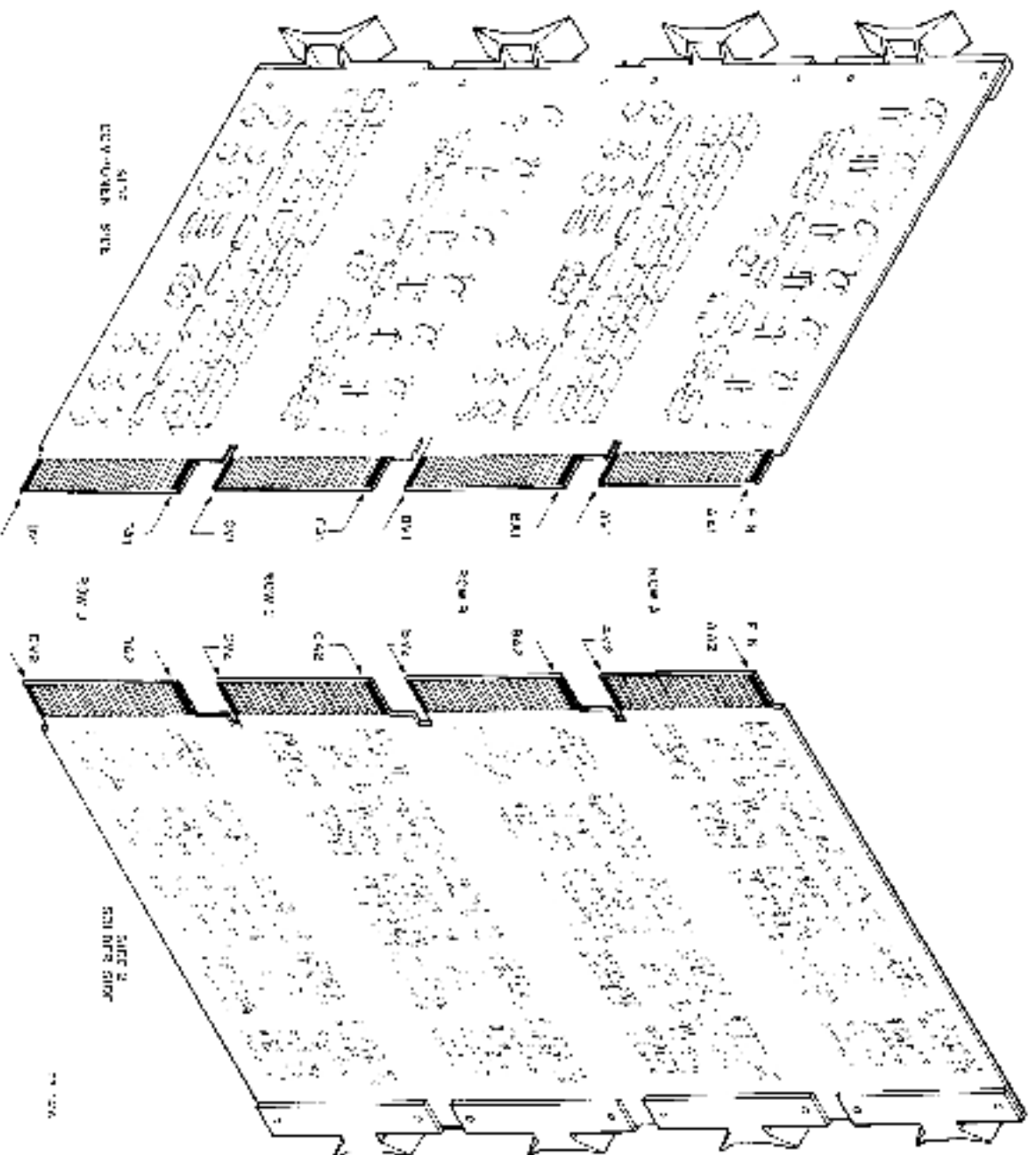

Figure 3-2 Quad Module Contract Finger Identification

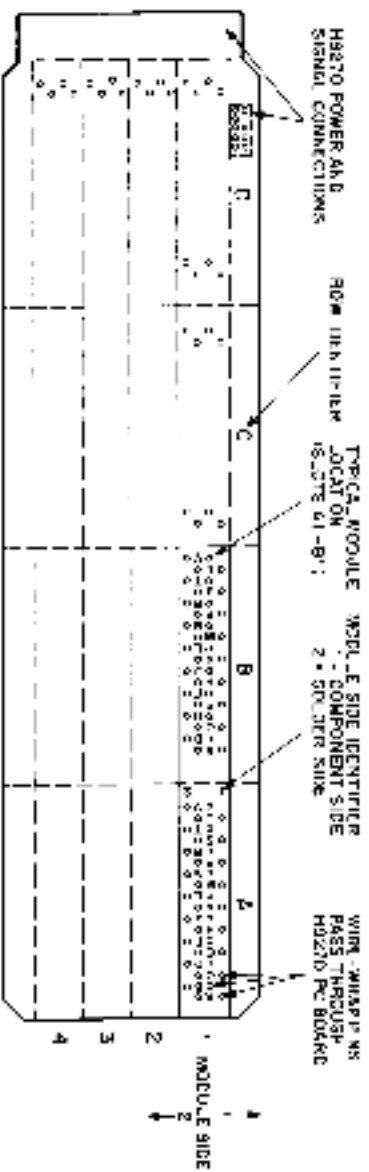

Figure 3-3 LSI-11, PDP-11/03 Backplane Module Pin Identification

3.4 BUS SIGNALS

H9270 backplane pin assignments are listed and described in Table 3-1. Only slots A and B are listed. However, they are identical to slots C and D,

respectively. Applicable bus cycle timing and specifications are discussed in Paragraphs 3.12, 3.13, and 3.14.

Table 3-1
Backplane Pin Assignments

Bus Pin	Mnemonic	Description
AA1 AB1 AC1 AD1	BSPARE1 BSPARE2 BAD16 BAD17	Bus Spare (Not Assigned. Reserved for DIGITAL use.) Extended address bits (not implemented)
AE1 AF1 AH1	SSPARE1 SSPARE2 SSPARE3	Special Spare (Not assigned, not bused. Available for user interconnections.)
AJ1	GND	Ground — System signal ground and dc return.
AK1 AL1	MSPAREA MSPAREA	Maintenance Spare — Normally connected on the backplane at each option location (not bused connection).
AM1	GND	Ground — System signal ground and dc return.
AN1	BDMRL	Direct Memory Access (DMA) Request — A device asserts this signal to request bus mastership. The processor arbitrates bus mastership between itself and all DMA devices on the bus. If the processor is not bus master (it has completed a bus cycle and BSYNC L is not being asserted by the processor), it grants bus mastership to the requesting device by asserting BDMGO L. The device responds by negating BDMRL and asserting BSACK L.
AP1	BHALT L	Processor Halt — When BHALT L is asserted, the processor responds by halting normal program execution. External interrupts are ignored but memory refresh interrupts (enabled if W4 on the processor module is removed) and DMA request/grant sequences are enabled. When in the halt state, the processor executes the ODT microcode and the console device operation is invoked.
AR1	BREFL	Memory Refresh — Asserted by a processor microcode-generated refresh interrupt sequence (when enabled) or by an external device. This signal forces all dynamic MOS memory units to be activated for each BSYNC L/BDIN L bus transaction.
<p>CAUTION</p> <p>The user must avoid using multiple DMA data transfers [Burst or "hog" mode] during a processor-generated refresh operation so that a complete refresh cycle can occur once every 1.6 ms.</p>		
AS1	PSPARE3	Spare (Not assigned. Customer usage not recommended.)
AT1	GND	Ground — System signal ground and dc return.
AU1	PSPARE1	Spare (Not assigned. Customer usage not recommended.)
AV1	+5B	—5 V Battery Power — Secondary +5 V power connection. Battery power can be used with certain devices.
BA1	BDCOK H	DC Power OK — Power supply-generated signal that is asserted when there is sufficient dc voltage available to sustain reliable system operation.

Table 3-1 (Cont)
Backplane Pin Assignments

Bus Pin	Mnemonic	Description
BB1	BPOKH	Power OK — Asserted by the power supply when primary power is normal. When negated during processor operation, a power fail trap sequence is initiated.
BC1	SSPARE4	Special Spare (Not assigned, not bused. Available for user interconnections.)
BD1	SSPARE5	
BE1	SSPARE6	
BF1	SSPARE7	
BH1	SSPARE8	
BJ1	GND	Ground — System signal ground and dc return.
BK1	MSPAREB	Maintenance Spare — Normally connected on the backplane at each option location (not a bused connection).
BL1	MSPAREB	
BM1	GND	Ground — System signal ground and dc return.
BN1	BSACK L	This signal is asserted by a DMA device in response to the processor's BDMGO L signal, indicating that the DMA device is bus master.
BP1	BSPARE6	Bus Spare (Not assigned. Reserved for DIGITAL use.)
BR1	BEVNT L	External Event Interrupt Request — When asserted, the processor responds (if PS bit 7 is 0) by entering a service routine via vector address 100 _h . A typical use of this signal is a line time clock interrupt.
BS1	PSPARE4	Spare (Not assigned. Customer usage not recommended.)
BT1	GND	Ground — System signal ground and dc return.
BU1	PSPARE2	Spare (Not assigned. Customer usage not recommended.)
+5V1	+5	+5 V Power — +5 Vdc system power.
AA2	+5	+5 V Power — Normal +5 Vdc system power.
AB2	-12	-12 V Power — -12 Vdc (optional) power for devices requiring this voltage.
NOTE		
ISI-11 modules which require negative voltages contain an inverter circuit (on each module) which generates the required voltage(s); hence, -12 V power is not required with DIGITAL-supplied options.		
AC2	GND	Ground — System signal ground and dc return.
AD2	-12	+12 V Power — -12 Vdc system power.
AE2	BDOUT L	Data Output — BDOUT L, when asserted, implies that valid data is available on BDAL0-15 L and that an output transfer, with respect to the bus master device, is taking place. BDOUT L is deskewed with respect to data on the bus. The slave device responding to the BDOUT L signal must assert BRPLY L to complete the transfer.
AF2	BRPLY L	Reply — BRPLY L is asserted in response to BDIN L or BDOUT L and during IAK transactions. It is generated by a slave device to indicate that it has input data available on the BDAL bus or that it has accepted output data from the bus.

**Table 3-1 (Cont.)
Backplane Pin Assignments**

Bus Pin	Mnemonic	Description
AH2	BDIN L	Data Input — BDIN L is used for two types of bus operations: <ol style="list-style-type: none"> 1. When asserted during BSYNC L time, BDIN L implies an input transfer with respect to the current bus master, and requires a response (BRPLY L). BDIN L is asserted when the master device is ready to accept data from a slave device. 2. When asserted without BSYNC L, it indicates that an interrupt operation is occurring. <p>The master device must de skew input data from BRPLY L.</p>
AJ2	BSYNC L	Synchronize — BSYNC L is asserted by the bus master device to indicate that it has placed an address on BDATA—15 L. The transfer is in process until BSYNC L is negated.
AK2	BWTBT L	Write/Byte — BWTBT L is used in two ways to control a bus cycle: <ol style="list-style-type: none"> 1. It is asserted during the leading edge of BSYNC L to indicate that an output sequence is to follow (DATA or DATOB), rather than an input sequence. 2. It is asserted during BDOUT L, in a DATOB bus cycle, for byte addressing.
AL2	BRQ L	Interrupt Request — A device asserts this signal when its Interrupt Enable and Interrupt Request flip-flops are set. This signal informs the processor that a device has data to input to the processor or it is ready to accept output data. If the processor's PS word bit 7 is 0, the processor responds by acknowledging the request by asserting BDIN L and BIAKO L.
AM2 AN2	BIAKI L BIAKO L	Interrupt Acknowledge Input and Interrupt Acknowledge Output — This is an interrupt acknowledge signal which is generated by the processor in response to an interrupt request (BRQ L). The processor asserts BIAKO L, which is routed to the BIAKI L pin of the first device on the bus. If it is requesting an interrupt, it will inhibit passing BIAKO L. If it is not asserting BRQ L, the device will pass BIAKI L to the next (lower priority) device via its BIAKO L pin and the lower priority device's BIAKI L pin.
AP2	BBS7 L	Bank 7 Select — The bus master asserts BBS7 L when an address in the upper 4K bank (address in the 28-32K range) is placed on the bus. BSYNC L is then asserted and BBS7 L remains active for the duration of the addressing portion of the bus cycle.
AR2 AS2	BDMGI L BDMGO L	DMA Grant-Input and DMA Grant-Output — This is the processor-generated daisy-chained signal which grants bus mastership to the highest priority DMA device along the bus. The processor generates BDMGO L, which is routed to the BDMGI L pin of the first device on the bus. If it is requesting the bus, it will inhibit passing BDMGO L. If it is not requesting the bus, it will pass the BDMGI L signal to the next (lower priority) device via its BDMGO L pin. The device asserting BDMR L is the device requesting the bus, and it responds to the BDMGI L signal by negating BDMR, asserting BSACK L, assuming bus mastership, and executing the required bus cycle.
		CAUTION DMA device transfers must be single transfers and must not interfere with the memory refresh cycle.
AT2	BNIT L	Initialize — BNIT is asserted by the processor to initialize or clear all devices connected to the I/O bus. The signal is generated in response to a power-up condition (the negated condition of BDCOK H).

Table 3-1 (Cont)
Backplane Pin Assignments

Bus Pin	Mnemonic	Description	
AU2 AV2	BDAL0 L BDAL1 L	Data/Address Lines — These 14 lines are part of the 16-line data/address bus previously described.	
BA2	+5		-5 V Power — Normal +5 Vdc system power.
BB2	-12		-12 V Power — -12 Vdc (optional) power for devices requiring this voltage.
BC2	GND		Ground — System signal ground and dc return.
BD2	+12		+12 V Power — +12 V system power
BE2	BDAL2 L		
BF2	BDAL3 L		
BH2	BDAL4 L		
BJ2	BDAL5 L		
BK2	BDAL6 L		
BL2	BDAL7 L		
BM2	BDAL8 L		
BN2	BDAL9 L		
BP2	BDAL10 L		
BR2	BDAL11 L		
BS2	BDAL12 L		
BT2	BDAL13 L		
BU2	BDAL14 L		
BV2	BDAL15 L		

3.5 BUS CYCLES

3.5.1 General

Every processor instruction requires one or more I/O operations. The first operation required is a data input transfer (DATI), which fetches an instruction from the location addressed by the program counter (PC or R7). This operation is called a DATI bus cycle. If no additional operands are referenced in memory or in an I/O device, no additional bus cycles are required for instruction execution. However, if memory or a device is referenced, additional DATI, data input/output (DATIO or DATIOB), or data output transfer (DATO or DATOB) bus cycles are required. Between these bus cycles, the processor can service DMA requests. In addition, the processor can service interrupt requests only prior to an instruction fetch (DATI bus cycle) if the processor's priority is zero. (PS word bit 7 is 0.)

The following paragraphs describe the types of bus cycles. Note that the sequences for I/O operations between processor and memory or between processor and I/O device are identical. DATO (or DATOB) cycles are equivalent to write operations, and DATI cycles are equivalent to read operations. In addition, DATIO cycles include an input transfer followed by an output

transfer. The DATIO cycle provides an efficient means of executing an equivalent read-modify-write operation by making it unnecessary to assert an address a second time.

3.5.2 Input Operations

The sequence for a DATI operation is shown in Figure 3-4. DATI cycles are asynchronous and require a response from the addressed device or memory. The addressed memory or device responds to its input request (BDIN L) by asserting BRPLY L. If BRPLY is not asserted within 10 μ s (max) after BDIN L is asserted, the processor terminates the cycle and traps through location 4.

Note that BWTBT L is not asserted during the address time, indicating that an input data transfer is to be executed.

A DATIO cycle is equivalent to a read-modify-write operation. An addressing operation and an input word transfer are first executed in a manner similar to the DATI cycle; however, BSYNC L remains in the active state after completing the input data transfer. This causes the addressed device or memory to remain

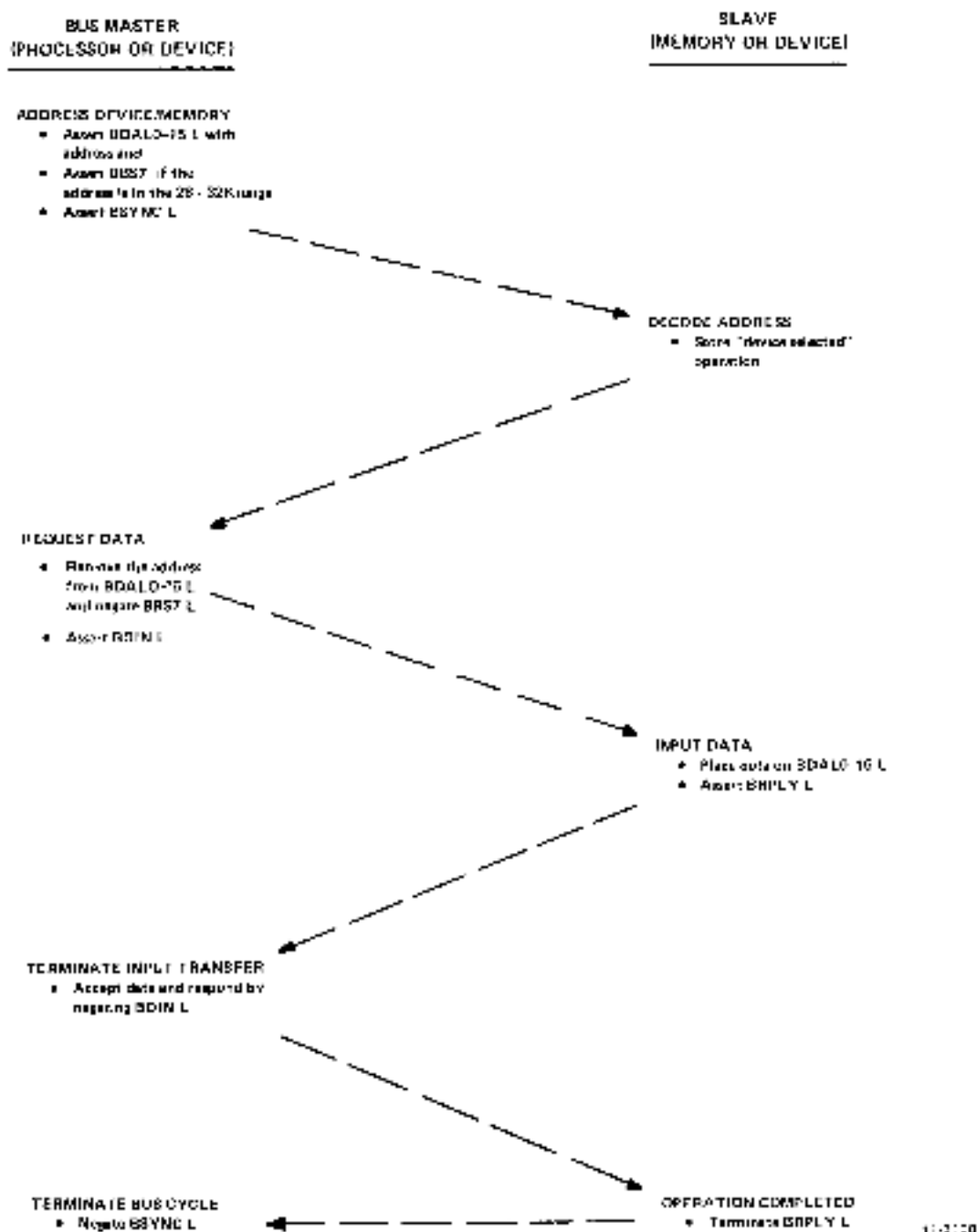

Figure 3-4 DATO Bus Cycle

selected, and an output data transfer follows without any further addressing. After completing the output transfer, the device terminates BSYN0 L, completing the DATO cycle. The actual sequence required for a DATO cycle is shown in Figure 3-5. Note that the output data transfer portion of the bus cycle can be a byte transfer; hence, this cycle is shown as DATOEB.

3.5.3 Output Operations

The sequence required for a DATO or the equivalent output byte (DATOEB) bus cycle is shown in Figure 3-6.

Like the input operations, failure to receive BRPLY L within 10µs after asserting BDIR0 L is an error, and results in a processor time-out trap through location 4.

Note that BWTBT L is asserted during the addressing portion of the cycle to indicate that an output data transfer is to follow. If a DATOEB is to be executed, BWTBT L remains active for the duration of the bus cycle; however, if a DATO (word transfer) is to be executed, BWTBT L is negated during the remainder of the cycle.

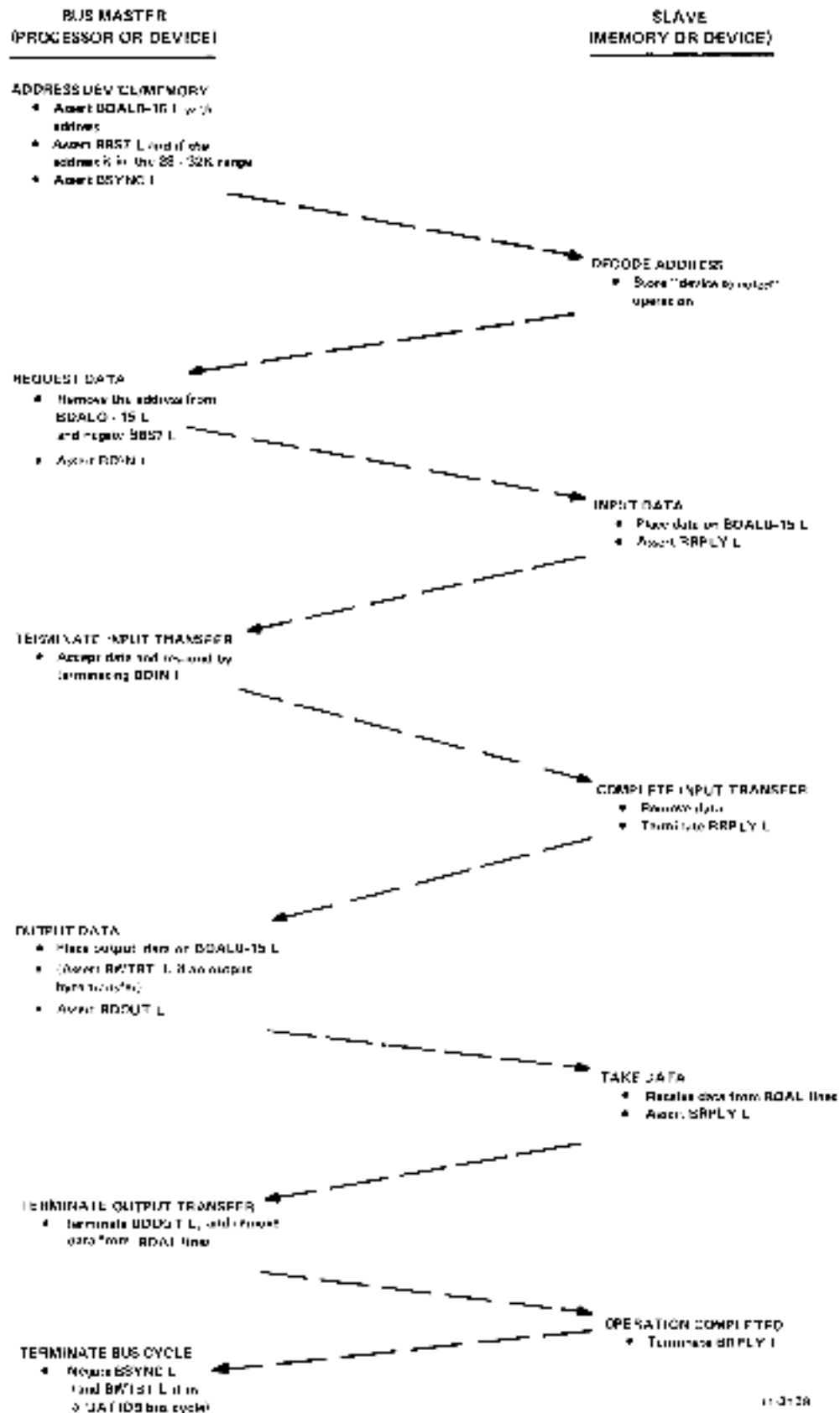
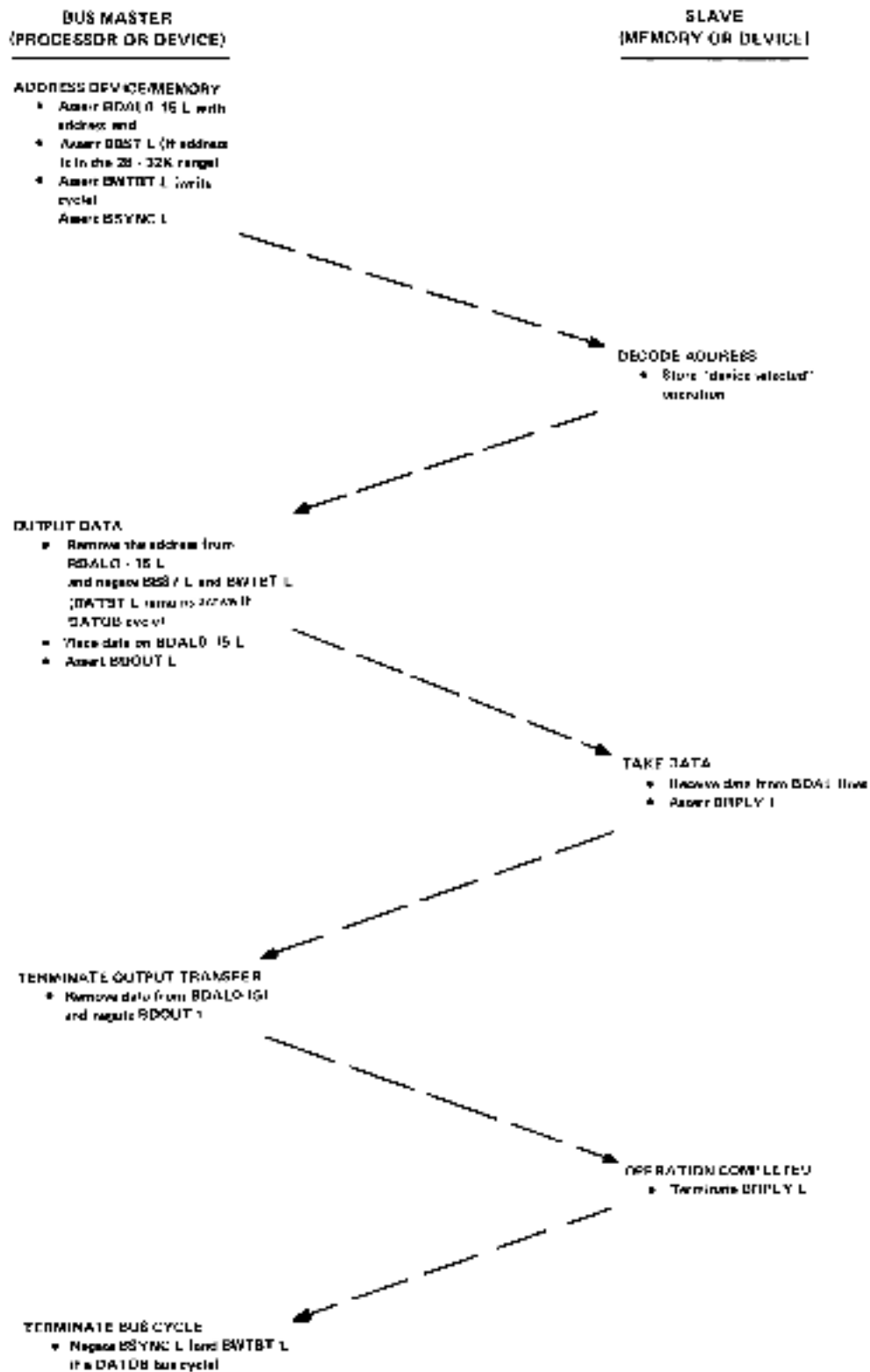

Figure 3-5 DAT10 or DAT10B Bus Cycle



11-3110

Figure 3-6 DATO or DATOB Bus Cycle

3.6 DMA OPERATIONS

DMA I/O operations involve a peripheral device and system memory. A device can transfer data to or from the 4K memory on the processor module or any read/write memory module along the bus. The actual sequence of operations for executing the data transfer once a device has been granted DMA bus control is as previously described for input and output I/O bus cycles, except the DMA device, not the processor, is bus master (controls the operation). Memory address-

ressing, timing, and control signal generation/response are provided by logic contained on the device's DMA interface module; the processor is not involved with address and data transfers during a DMA operation.

The required DMA sequence is shown in Figure 3-7. A device requests the I/O bus by asserting **BDMR L**. After completing the present bus cycle, the processor responds by asserting **BDMGO L**, allowing the device

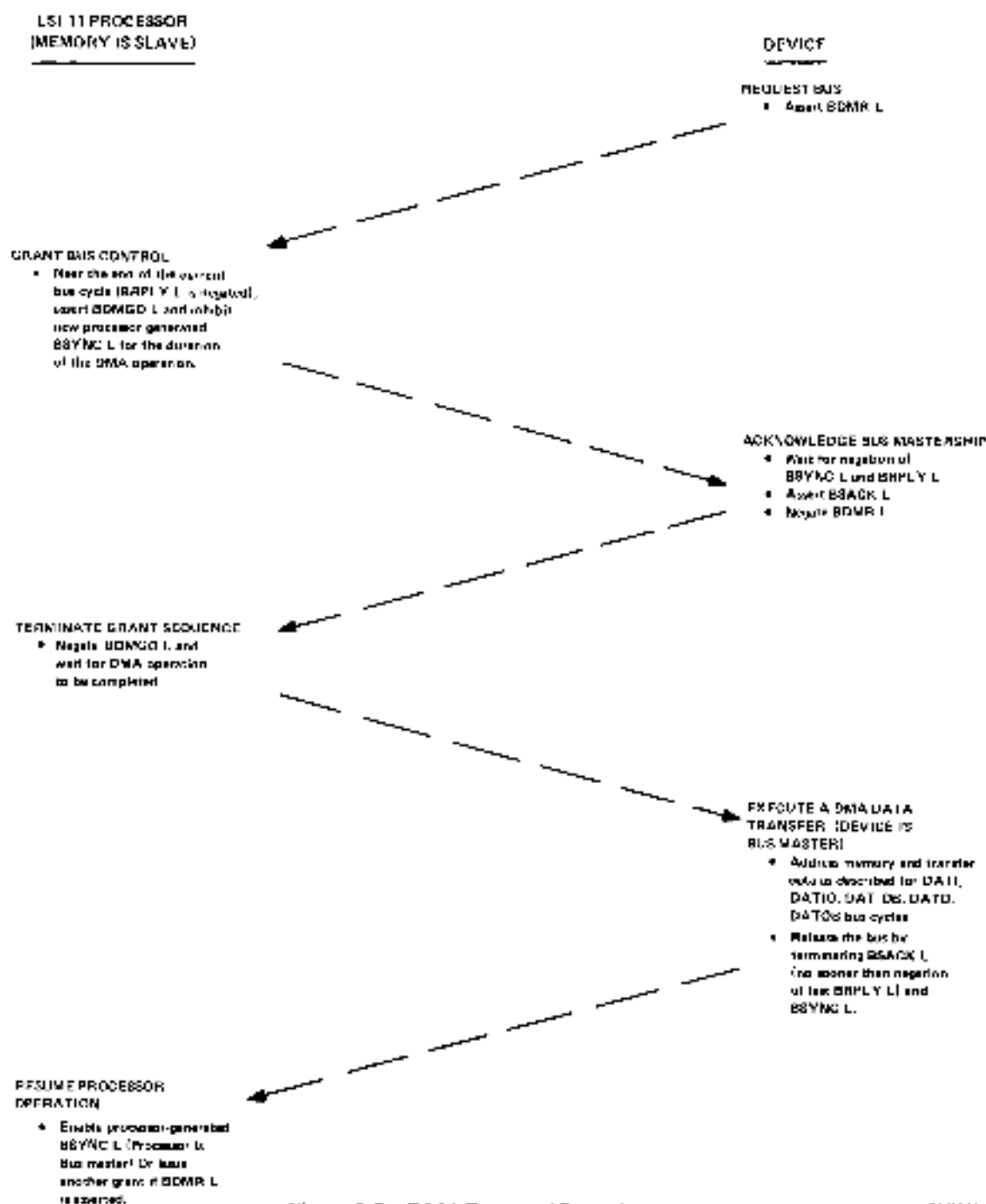

Figure 3-7 DMA Request/Grant Sequence

11-1147

to become bus master. It also inhibits further processor generation of **BSYNC L**, preventing processor-initiation of a new bus cycle. The device responds by asserting **BSACK L** and negating **BDMR L**, causing the processor to terminate **BDMGO L**; the device is now bus master and it can execute the required data transfer in the same manner described for a **DATI**, **DATIO**, **DATIOB**, **DATO**, or **DATIOB** bus cycle. When the data transfer is completed, the device returns bus master control to the processor by terminating the **BSACK L** and **BSYNC L** signals.

3.7 INTERRUPTS

Interrupts are requests made by peripheral devices which cause the processor to temporarily suspend its present (background) program execution to service the requesting device. Each device which is capable of requesting an interrupt has a service routine which is automatically entered when the processor acknowledges the interrupt request. After completing the service routine execution, program control is returned to the interrupted program. This type of operation is especially useful for the slower peripheral devices.

A device can interrupt the processor only when interrupts are enabled and the device is the closest device to the processor along the I/O bus. The processor's priority in the **PS** word is 4 when external interrupts are disabled and 0 when external interrupts are enabled. Device priority is highest for devices electrically closest to the processor along the bus.

Any device that can interrupt the processor can also interrupt the service routine execution of a lower priority device if the processor's priority is 0 during that execution; hence, interrupt nesting to any level is possible with this interrupt structure. Each device normally contains a control status register (CSR), which includes an interrupt enable bit. A program must set this bit before an interrupt request can actually be granted to a device.

An interrupt vector associated with each device is hard-wired into the device's interface/control logic. This vector is an address pointer that allows automatic entry into the service routine without device polling.

When an interrupt request is issued via the external event signal line, the processor automatically services the request via location 100_1 ; it does not input a vector address as done for other external interrupt devices. This interrupt function is normally used for a time clock input based on the frequency of the local ac power (50 or 60 Hz).

The interface control and data signal sequence required for interrupts is shown in Figure 3-8. A device requests interrupt service by asserting **BRQ L**. The processor can acknowledge interrupt requests only between instruction executions by generating an active (low) **BDIN L** signal, enabling the device's vector response. The processor then asserts the **BIAKO L** signal. The first device on the bus receives this daisy-chained signal at its **BIAKI L** input. If it is not requesting service, it passes the signal via its **BIAKO L** output to the next device, and so on, until the requesting device receives the signal. The device that did not pass the **BIAKO L** signal responds by asserting **BRPLY L** (low) and placing its interrupt vector on data/address bus lines **BDAL0—15 L**. Automatic entry to the service routine is then executed by the processor as previously described.

NOTE

If a device fails to assert BRPLY L in response to BDIN L within 10 μ sec, the processor enters the Halt state.

3.8 BUS INITIALIZATION

Devices along the I/O bus are initialized whenever the system dc voltages are cycled on or off, or when a **RESET** instruction is executed. Initialization during the power-on/power-off sequence is described in Paragraph 3.9. When the **RESET** instruction is executed, the processor responds by asserting **BNIT L** for approximately 10 μ s. Devices along the bus respond to the **BNIT L** signal, as appropriate, by clearing registers and presetting or clearing flip-flops.

3.9 POWER-UP/POWER-DOWN SEQUENCE

Power status signals **BPOK H** and **BDCOK H** must be asserted or negated in a particular sequence as dc operating power is applied or removed. Initially, **BDCOK H** and **BPOK H** are passive (low). As dc voltages rise to operating levels, **BNIT L** is asserted by the processor module. Approximately 3 ms (min) after -5 V and $+12$ V power are normal, an external signal source, or the H780 power supply in PDP-11/03 systems, produces an active **BDCOK H** signal; the processor responds by negating **BNIT**, and waits for **BPOK H**. The **BPOK H** signal, produced by an external signal source or the H780 power supply, goes true (high) 70 ms (min) after **BDCOK H** goes high. The processor responds by executing the user-selected power-up routine (Chapter 5); if **BHALT L** is asserted, the console microcode is executed.

During a power-down sequence, the external signal source first negates **BPOK H**, causing the processor to execute the power-fail trap (PC at 024, PS at 026).

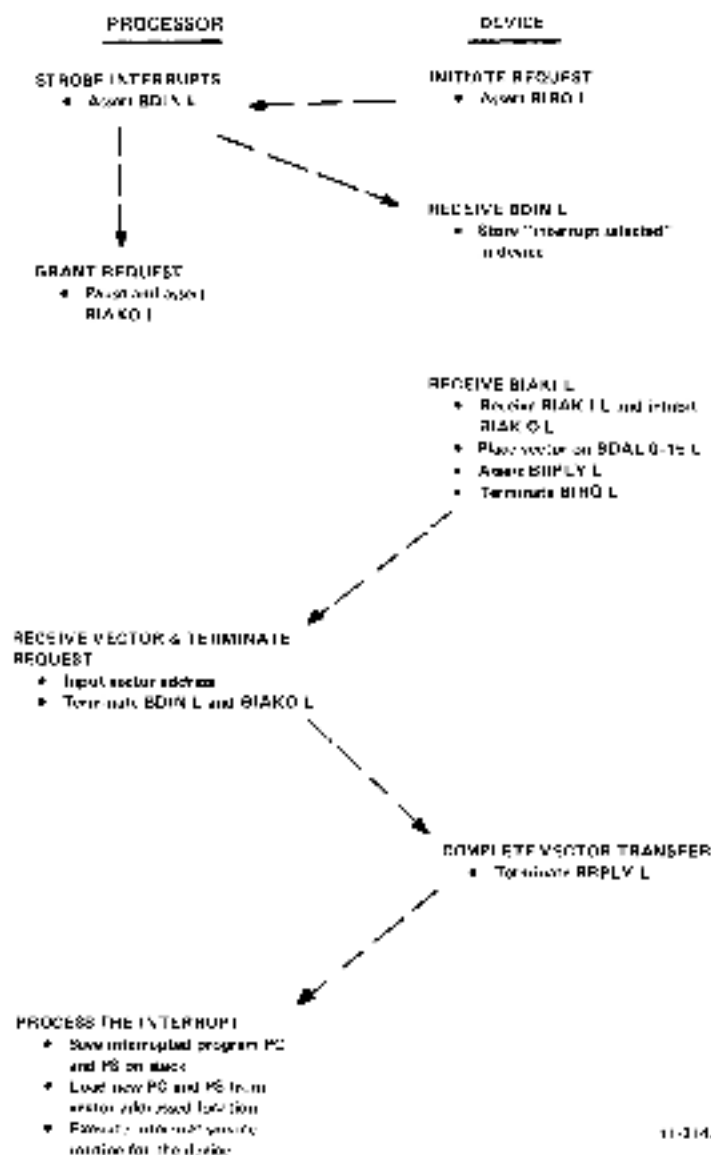

Figure 3-8 Interrupt Request/Acknowledge Sequence

Approximately 3 ms (max) later, the processor initializes the bus by asserting **BJNTT L** in response to the external signal negation of **BDCOK H**.

3.10 HALT MODE

The **BHALT L** bus signal can be asserted low to place the processor in the Halt mode. When in the Halt mode, the RUN indicator (PDP-11/03 only) is extinguished, interrupts external to the processor module are ignored, and the processor executes the console **ODI** microcode. Although the user could assert this line by a separate switch or a custom module, it is normally asserted by the **HALT/ENABLE** switch (PDP-11/03 only) or the user-designated device's **STU**

interface module when the Framing Error Halt is enabled (Paragraph 6.2.2.6). Note that when in the Halt mode, the processor arbitrates DMA requests, and refresh operations. Thus, in addition to bus transactions between the processor and the console device, bus transactions can occur for DMA and refresh.

3.11 MEMORY REFRESH

Memory refresh operations are required when any dynamic MOS memory devices are used in a system. These memory devices are included on **KD11 F** and **MSV11-B** modules. Memory refresh is normally controlled by the processor microcode, which is automatically executed once every 1.6 ms. However, refresh

could be controlled by a user-supplied DMA device on the bus. (For example, when used in an intelligent terminal application, the refresh logic could be included on the user's DMA interface module.)

A complete refresh operation requires 64 BSYNC/BDIN transactions which must be completed within 2 ms. The processor (or other device controlling the refresh operation) first asserts BREFL for each BSYNC/BDIN transaction during the addressing portion of each refresh operation. BREFL causes all dynamic MOS memory devices to be simultaneously enabled and addressed, overruling local bank selection circuits. Refresh is then accomplished by executing 64 BSYNC/BDIN transactions, in a manner similar to the DATA bus cycle, incrementing the "row" address (bits 1—6) once for each transaction. Address bit 0 is not significant in the refresh operation. When refresh is controlled by processor microcode, the operation takes approximately 130 μ s.

Note that only one dynamic MOS memory device is required to assert BRPLYL during the refresh BSYNC/BDIN transactions. This should be performed by the slowest device on the bus. MSV11-B modules each contain a jumper which the user can insert to prevent the module from asserting BRPLYL during refresh operations. The slowest memory device will normally be the MSV11-B module located the greatest electrical distance from the processor module along the bus.

3.12 BUS SPECIFICATIONS

Electrical

Refer to electrical specifications listed in Paragraph 2.9.

NOTE

All bus lines are open-collector, resistor-terminated to a 3.4 V nominal.

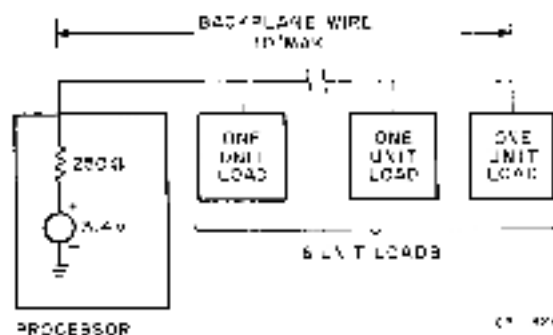

Figure 3-10 Minimum Configurations

Bus Drivers and Receivers

Recommended Bus Drivers

Type 957, P/N DFC 8881-1, quad 2-input NAND gates (Refer to specifications in Table 10-1.)

Recommended Bus Receivers

Type 956, P/N DFC 8640, quad 2-input NOR gates (Refer to specifications in Table 10-1.)

Recommended Bus Transceivers

Type DEC 8641, quad unified bus transceiver.

3.13 BUS CONFIGURATIONS

In the following descriptions, a unit load is equal to one bus receiver and two bus drivers and less than 10 pF of circuit board elch. Bus terminations are shown in Figure 3-9.

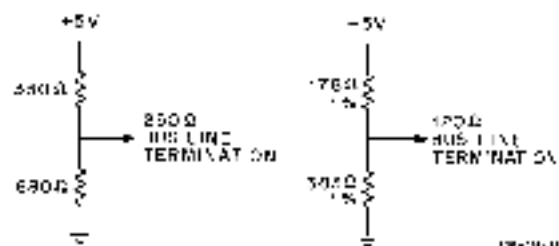

Figure 3-9 Bus Line Terminations

Minimum Configuration (Figure 3-10)

1. The processor terminates the bus lines to $Z_1 = 250 \Omega$.
2. Ten-inch maximum backplane wire (each bus line for a 4 by 4 backplane), 6 unit loads or less.

Intermediate Configuration (Figure 3-11)

1. The processor terminates the bus lines to $Z_1 = 250 \Omega$.

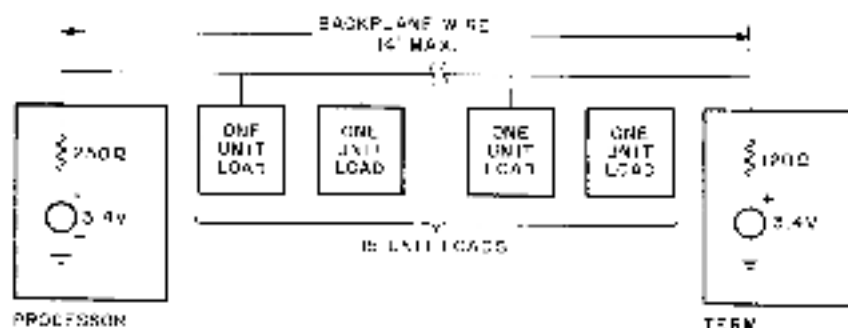

Figure 3-11 Intermediate Configuration

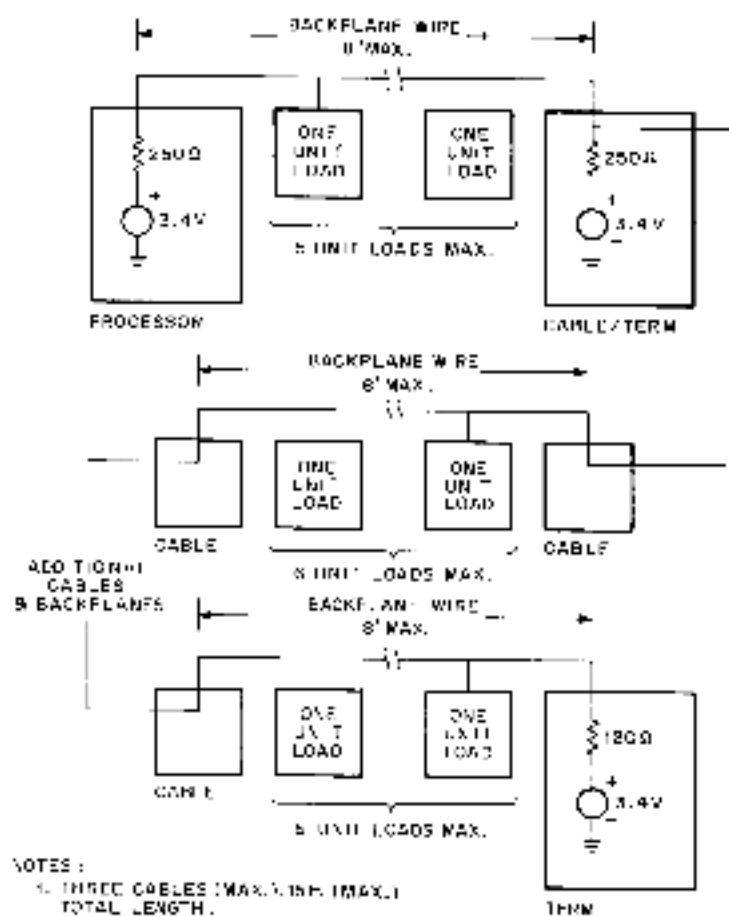

Figure 3-12 Maximum Configuration

2. Fourteen-inch maximum backplane wire (each bus line for a 9 by 4 backplane), 15 unit loads or less.
3. An additional 120 Ω termination is required.

Maximum Configuration (Figure 3-12)

1. The processor terminates the bus lines to $Z_t = 250 \Omega$.
2. Eight-inch maximum backplane wire on each backplane (each bus line for 4 by 4

backplanes); 5 unit loads maximum each backplane, 15 unit loads total (maximum); daisy-chained on 2 ft (minimum) 120 Ω cable, three cables maximum, total cable length not exceeding 15 ft.

3. Two additional terminations (one 250 Ω and one 120 Ω) are required.

3.14 BUS SIGNAL TIMING

Bus signal timing requirements at master and slave devices are shown in Figures 3-13 through 3-18.

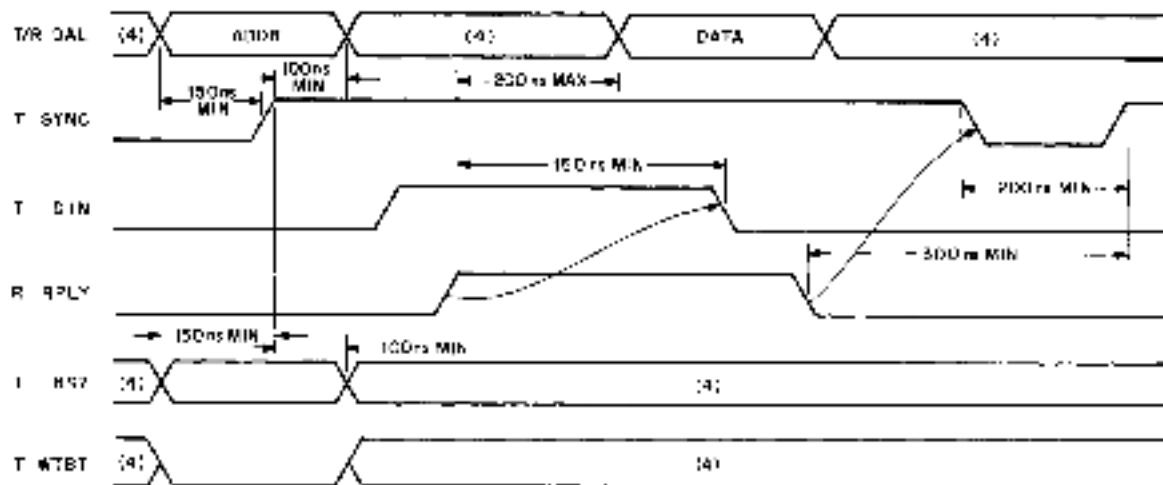

TIMING AT MASTER DEVICE

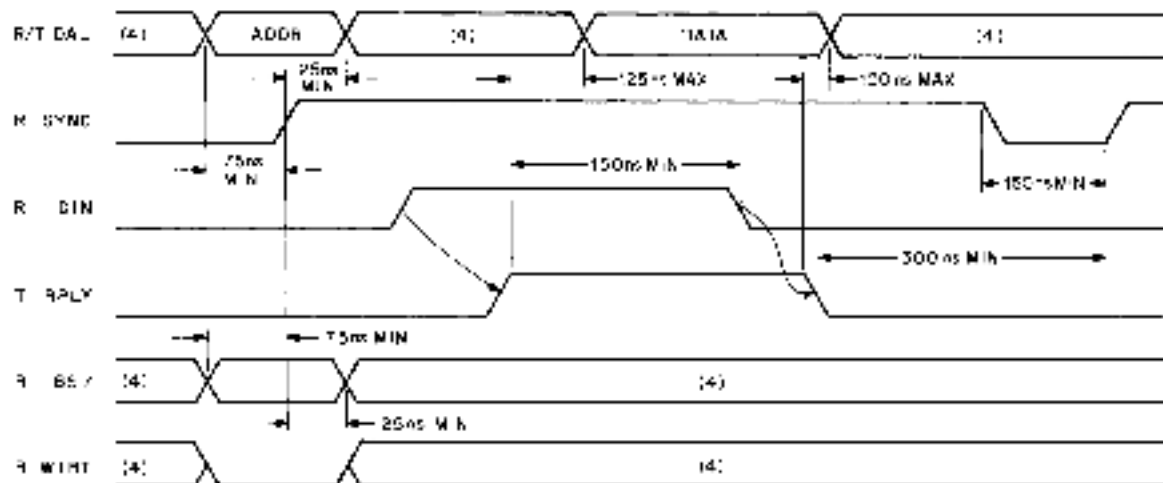

TIMING AT SLAVE DEVICE

NOTES

1. Timing shown at Master and Slave Device Bus Driver Inputs and Bus Receiver Outputs.
2. Signal name prefixes are defined below:
T = Bus Driver Input
R = Bus Receiver Output
3. Bus Driver Output and Bus Receiver Input signal names include a "d" prefix.
4. Don't care condition.

DS-1000

Figure 3-13 DAT1 Bus Cycle Timing

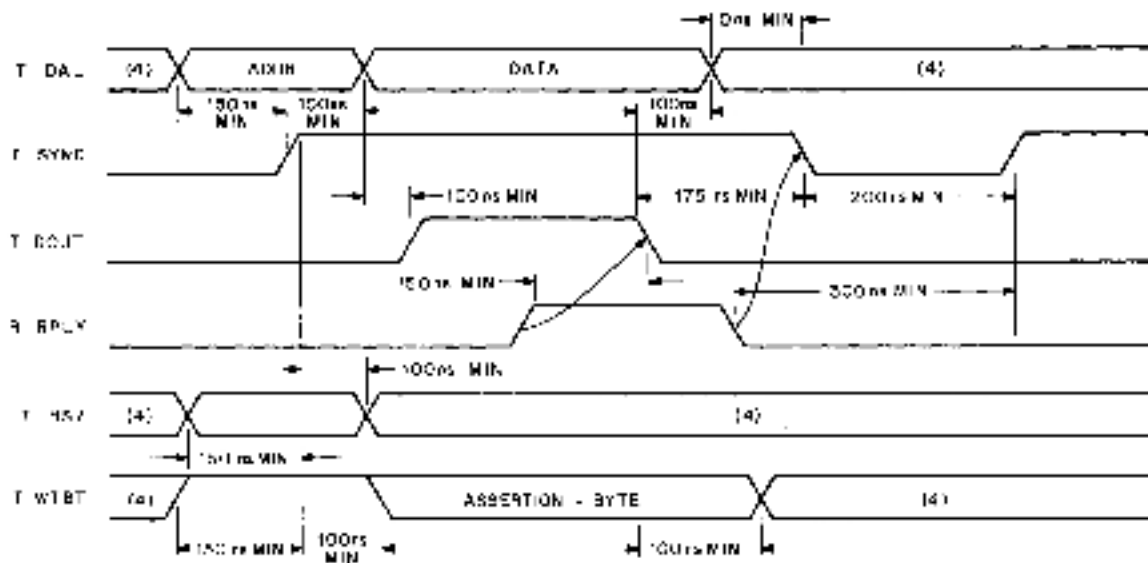

TIMING AT MASTER DEVICE

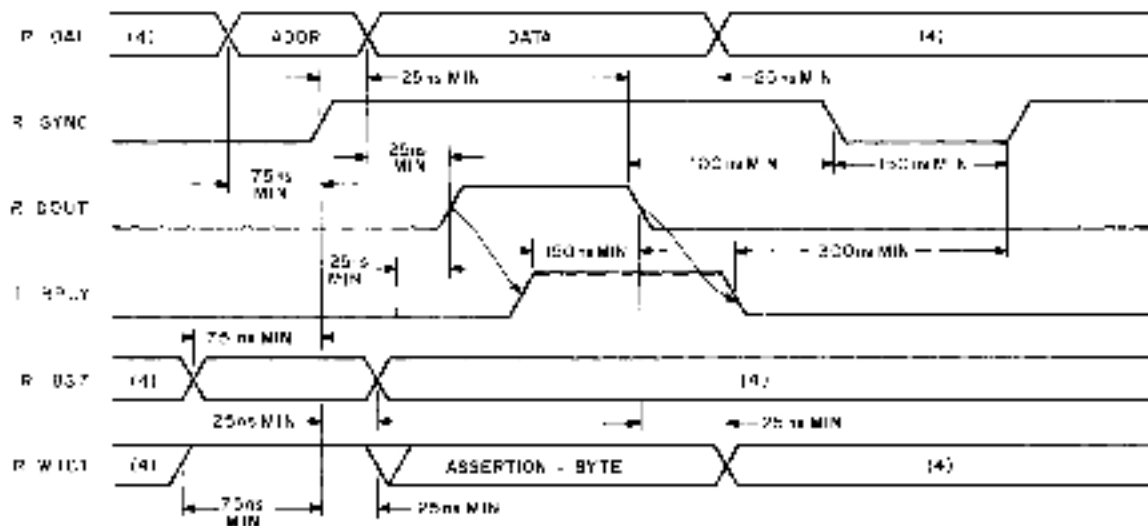

TIMING AT SLAVE DEVICE

NOTES

1. Timing shown at Master and Slave Device Bus Driver Inputs and Bus Receiver Outputs.
2. Signal name prefixes are defined as:
 - T = Bus Driver Input
 - R = Bus Receiver Output
3. Bus Driver Output and Bus Receiver Input signal names include a "R" prefix.
4. Don't care condition.

DS-1174

Figure 3-14 DATO or DATOB Bus Cycle Timing

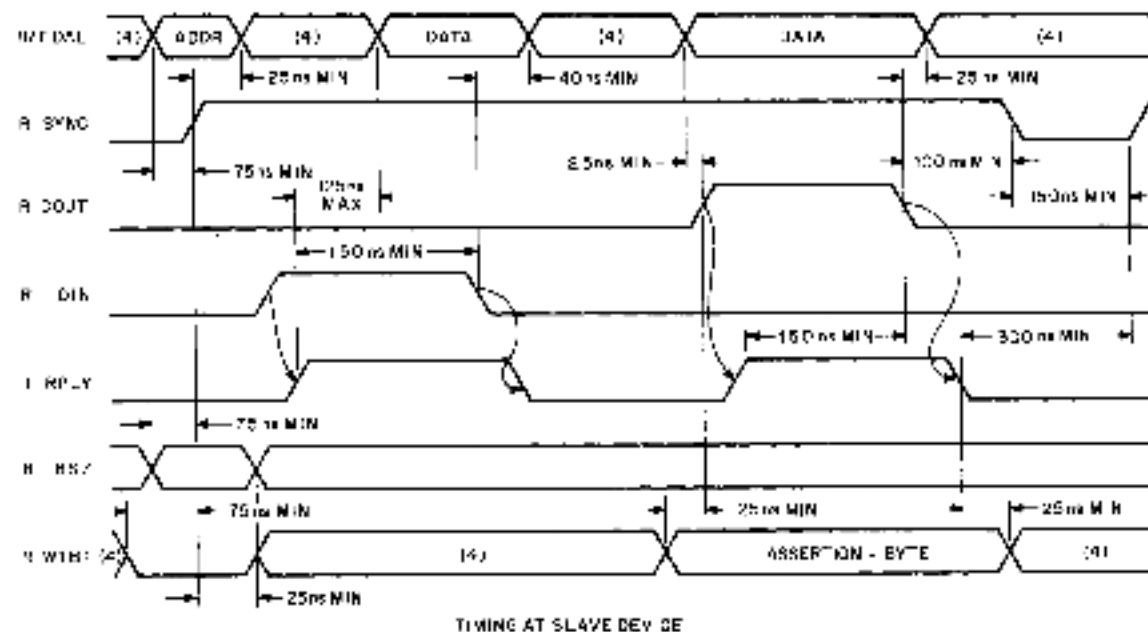
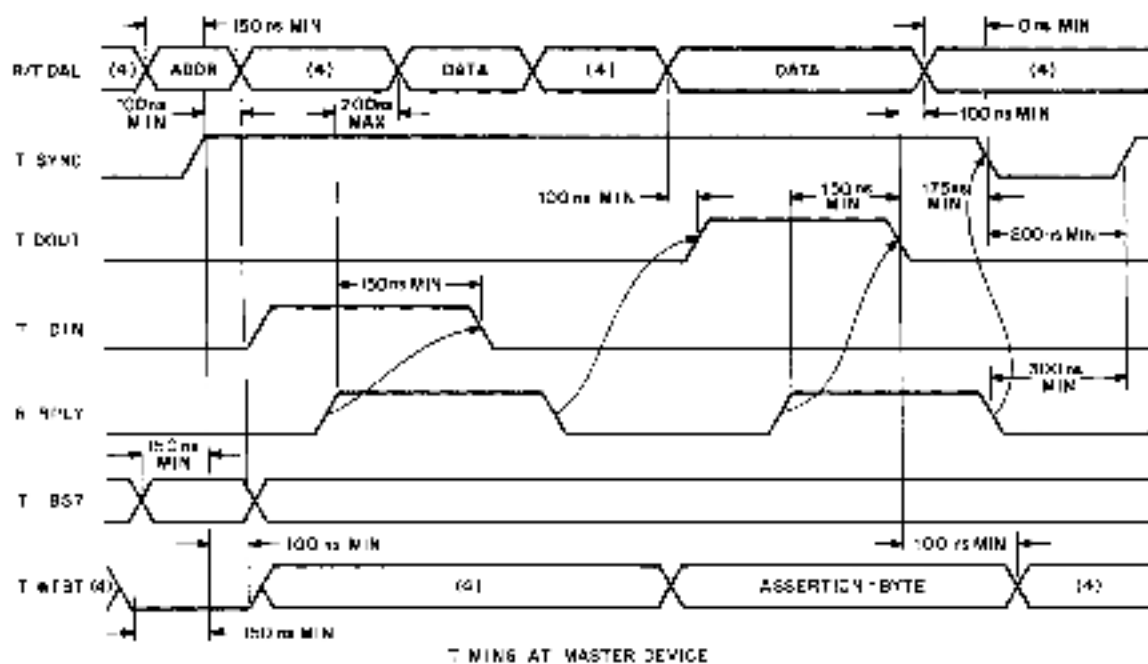

- NOTES:
1. Timing shown at Requesting Device
Bus Driver Inputs and Bus Receiver Outputs
 2. Signal name prefixes are defined below.
T = Bus Driver Input
R = Bus Receiver Output
 3. Bus Driver Output and Bus Receiver Input
signal names include a "B" prefix
 4. Don't care condition

GM-11112

Figure 3-15 DAT10 Bus Cycle Timing

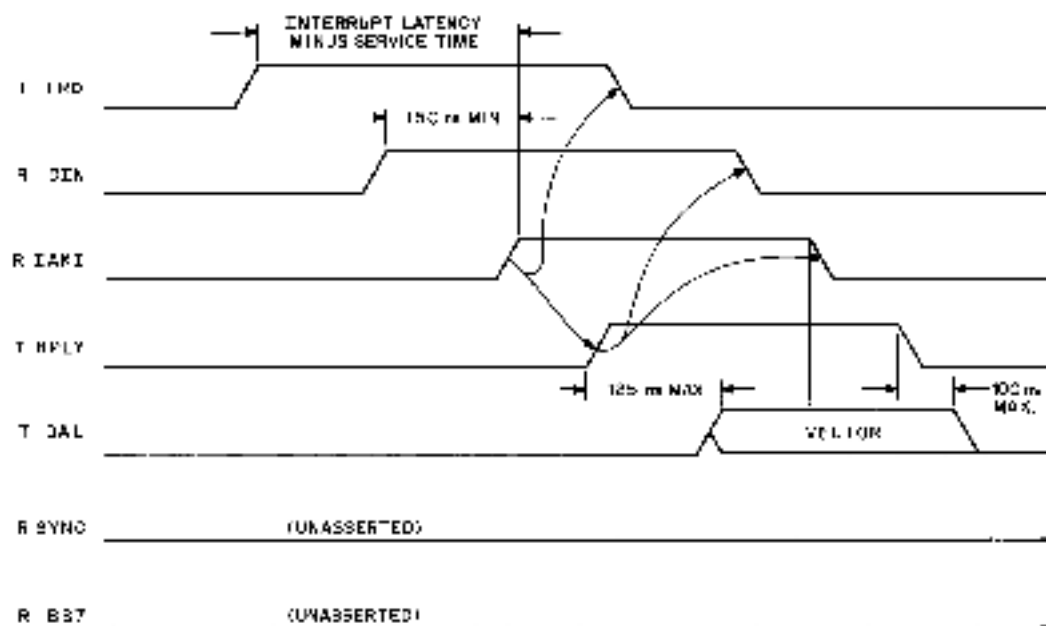

NOTES

1. Timing shown is Requesting Device Bus Driver Inputs and Bus Receiver Outputs.
2. Signal Name Prefixes are defined below:
 T - Bus Driver Output
 R - Bus Receiver Output
3. Bus Driver Output and Bus Receiver Inputs guaranteed include a "0" profile.

27-1777

Figure 3-16 Interrupt Transaction Timing

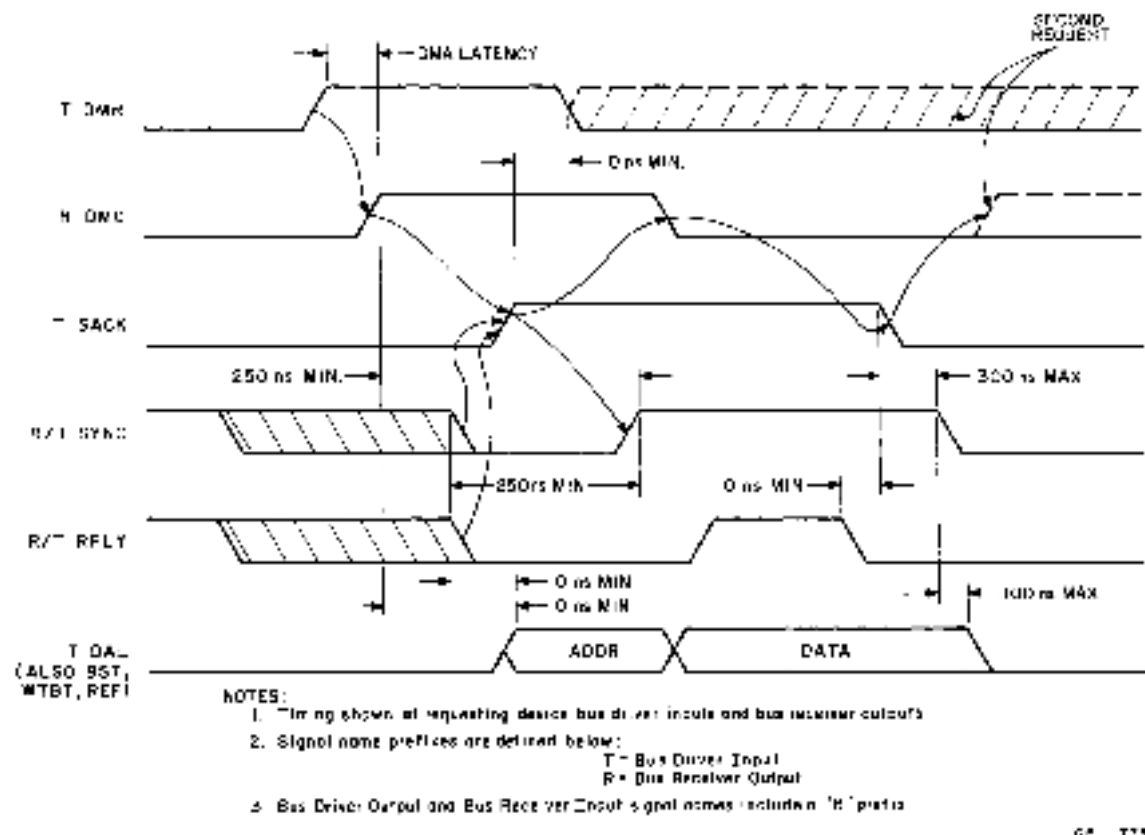

Figure 3-17 DMA Request/Grant Timing

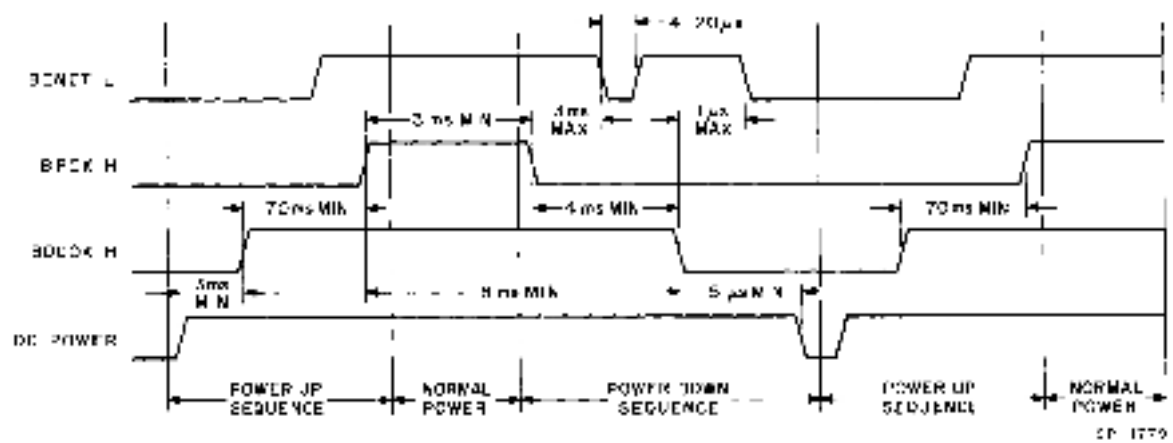

Figure 3-18 Power-Up/Power-Down Timing

CHAPTER 4

LSI-11 MODULE DESCRIPTIONS

4.1 GENERAL

This chapter contains detailed descriptions of each LSI-11 module. The level of coverage is sufficient to enable users to interface their systems with the PDP-11/03 or LSI-11 using standard LSI-11 modules or user-designed interfaces. Refer to Chapter 3 for detailed bus timing information.

LSI-11 modules covered in this chapter are listed in Table 4-1. Note that a separate description for the KD11-J microcomputer is not provided; it comprises the same M7264 module as the KD11-F microcomputer, except that a resident semiconductor memory is not supplied. Instead, the MMV11 core memory module is supplied with the KD11-J option.

Table 4-1
LSI-11 Modules

Option	Module Number	Module Option	Description Para. No.
KD11-F	M7264	LSI-11 microcomputer and 4K semiconductor memory	4.2
KD11-J	M7264-YA, H223, G653	LSI-11 microcomputer and 4K core memory	4.2
KEV-11	—	EIS/FIS processor chip	4.2
MMV11-A	H223, G653	4K by 16-bit core memory	4.3
MRV11-A	M7942	4K by 16-bit PROM	4.4
MSV11-B	M7944	4K by 16-bit dynamic read-write memory	4.5
DLV11	M7940	Serial line unit	4.7
DRV11	M7941	Parallel line unit	4.8
H780-A and H780-B		Power Supply	4.9

4.2 KD11-F MICROCOMPUTER

4.2.1 General

The KD11-F microcomputer is contained on a single 8.5 by 10 inch printed circuit board (M7264). The module includes all basic microcomputer functions common to both the KD11-F and KD11-J microcomputers and a resident 4K by 16-bit semiconductor read/write memory. KD11-F functions are shown in

Figure 4-1. KD11-F microcomputers features are given in Paragraph 2.3.

NOTE

The following description reflects the circuits shown in drawing CS M7264 Rev. E.

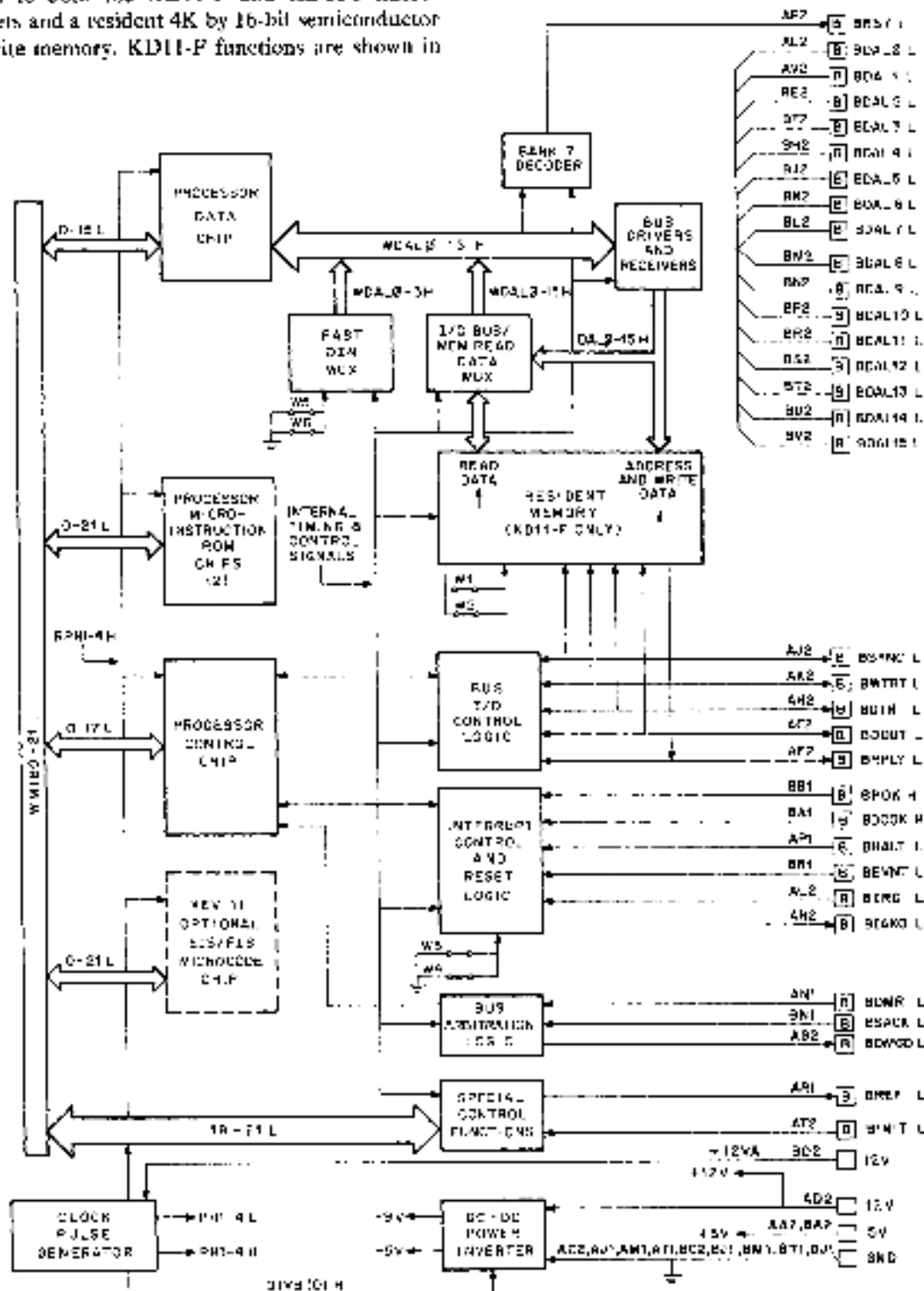

Figure 4-1 KD11-F Microcomputer Logic Block Diagram

4.2.2 Basic Microcomputer Functions

Basic functional blocks of the LS1-11 microcomputer are shown in Figure 4-1 and described in the following paragraphs. The KD11-F's resident memory is described separately (Paragraph 4.2.3).

4.2.2.1 Microprocessor Chip Set — The main function contained on the processor module is the microprocessor chip set. This chip set includes a control chip, a data chip, and two microinstruction ROM chips (microms). In addition, an optional KEY-11 microm (that contains EIS/FIS microcode) can be installed on the module. Microprocessor chips communicate with each other over a special 22-bit microinstruction bus, WMIB0-21 L. All address and data communication between the microprocessor chips and other processor module functional blocks is via the data chip and the 16-bit data/address lines, WDALO-15 H (from the data chip).

Processor module control signals interface with the microprocessor chips via the control chip. Eight input and five output microprocessor control signals provide this function.

Timing and synchronization of all microprocessor chips (and all processor module functions) are controlled by four nonoverlapping clock generator signals (Paragraph 4.2.2.2). Typical operating speed is approximately 400 ns (100 ns each phase), based on a 10 MHz oscillator signal.

The control chip generates a sequence of microinstruction addresses which access the microinstruction microm chips. The addressed microinstruction is then transferred to the data and control chips. Most of the microinstructions are executed by the data chip; however, various jumps, branches, and I/O operations are executed in the control chip.

The data chip contains the data paths, logic, arithmetic logic unit (ALU), processor status bits, and registers that are most familiar to PDP-11 and LS1-11 users. Registers include the eight general registers (R0-R7) and an instruction register. The user's program has access to all general registers and processor status (PS) bits. All PDP-11 instructions enter this chip via the WDAL bus. Data and addresses to and from the microprocessor are also transferred to and from the processor over this 16-bit bus.

CAUTION

Do not remove processor chips from their sockets. Improper handling could permanently damage the chips.

4.2.2.2 Clock Pulse Generator — The clock pulse generator produces four nonoverlapping clock signals for processor timing and synchronization. A voltage-controlled oscillator generates a basic 10 MHz CK H signal.

Maintenance clock gates receive and distribute the basic CK H signal to a two-stage counter and an RC filter circuit. The two-stage counter outputs are decoded by the four-state decoder, producing the basic four nonoverlapping clock phases. The pulse produced on the leading edge of each basic clock pulse inhibits the decoder for 10 ns, preventing the overlap of each phase. Each of the four phase signals (RPH1 through RPH4) are positive-going, MOS-compatible 100 ns (nominal) pulses which are bused to each of the microprocessor chips through resistors. PH1 L through PH4 L and PH1 H through PH4 H are similarly timed; however, they are TTL-compatible for distribution elsewhere on the module.

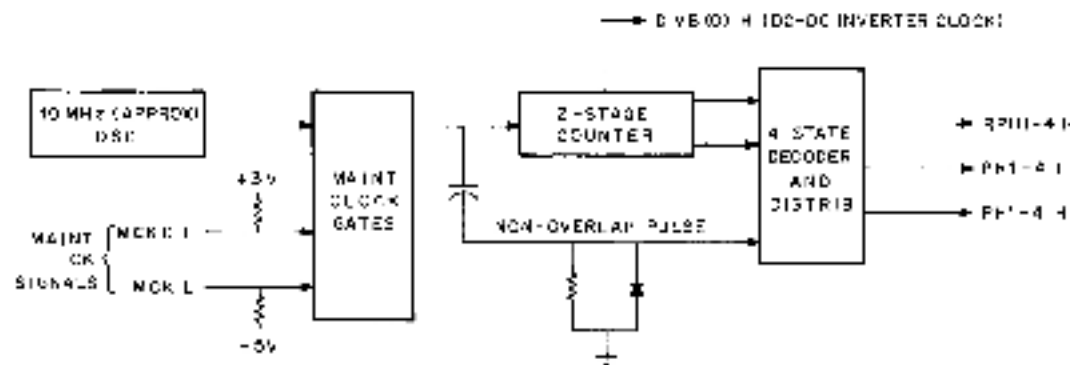

Figure 4-2 Clock Pulse Generator

4.2.2.3 Bus Interface and Data/Address Distribution All LSI-11 processor module communication to and from external I/O devices and memories is accomplished using the LSI-11 bus 16-bit data/address lines (BDAL0-15 L) and bus control signals. The processor module interfaces to the bus using bus driver/receiver chips, as shown in Figure 4-3. Each DEC 8641 chip contains four open-collector drivers and four high impedance receivers. Each driver output is common to a receiver input. Hence, either processor output data (from the driver outputs) or input data (from the bus) can stimulate bus receiver inputs.

Note that all four drivers in a chip are enabled or disabled by a pair of DRIVER ENABLE L inputs. A high input will inhibit all four drivers; when both enable inputs are low, the drivers are enabled and output data is gated onto the bus. Signals which control bus drivers include EDAL L, INIT (I) H, and DMGCY H. False states enable certain control signals which are described later.

EDAL L is a control signal which enables the 16-bit data/address bus drivers. When in the active state, EDAL L gates WDAL0-15 H onto the BDAL0-15 L bus.

EDAL L is generated by the logic shown in Figure 4-4. During a processor-controlled address/data output bus cycle, or during the addressing portion of a processor-controlled input bus cycle, SACK L and DMG(L) L are passive (high). The passive signals are gated, producing a low (passive) DMGCY H signal. This signal is inverted and gated with the passive DIN L signal, producing the active EDAL L signal. During a DMA cycle in which data in the processor module's resident 4K memory is to be read by a DMA device, BANK OR REF H goes high; this signal is gated with DINR H and DMG CYCLE H to produce the active EDAL L signal.

DMGCY H and INIT (I) H are processor module logic control signals which inhibit certain bus drivers during an Initialize or DMA operation. Bus drivers are enabled when these signals are in the false (low) state.

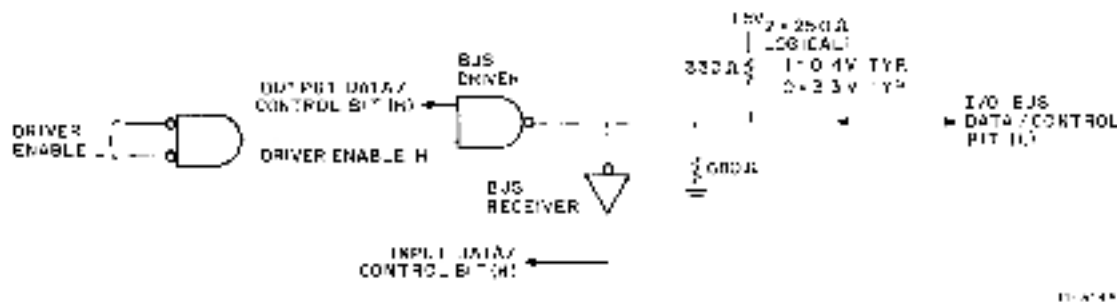

Figure 4-3 LSI-11 Bus Loading and Driver/Receiver Interface

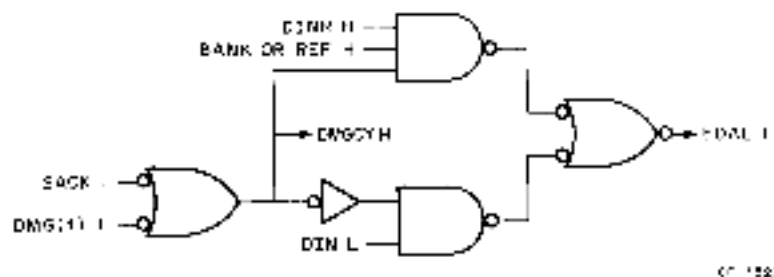

Figure 4-4 EDAL L Logic

A list of bus driver output signals and their respective enable signals is provided below.

Bus Driver (Signal)	Enable Signal(s) (Low = Enable)
BDAL0-15 L	BDAT L
BSYNC L	INIT (1) H, DMGCY H
BBS7 L	
BRPLY L	INIT (1) H
BLAKO L	
BDMG L	
BRPLY L	
BDIN L	
BDOU L	
BWTBT L	Always enabled
BINIT L	

The near-end bus termination resistors are contained on the processor module. Each bus driver output is terminated by a pair of resistors, as shown in the figure, establishing the nominal 250 Ω bus impedance and the 3.4V nominal voltage level. No additional terminations are required for bus-compatible devices connected to the same backplane.

Address and data information are distributed on the processor module via the WDAL0-15 H and DAL0-15 H 16-bit buses. WDAL0-15 H interface directly with the microprocessor's data chip, the DEC 8641 bus drivers, and the I/O bus/memory read data multiplexer. All processor input data from the I/O bus is via the bus receivers, the DAL0-15 H bus, the data multiplexer, the WDAL0-15 H bus, and the microprocessor's data chip. Resident memory data input is discussed later.

4.2.2.4 Bus I/O Control Signal Logic — Bus I/O control signals include BSYNC L, BWTBT L, BDIN L, BDOU L, and BRPLY L. In addition, BLAKO L can be considered a bus I/O control signal; however, since it is only used during the interrupt sequence, it is discussed in Paragraph 4.2.2.6. Logic circuits which produce and/or distribute these signals are shown in Figure 4-5. Each signal is generated or received as described in the following paragraphs.

BSYNC L — The control chip initiates the BSYNC L signal sequence by raising WSYNC H during PH2. Inverters apply the high SYNC H signal to the Sync flip-flop D input. On the trailing edge of PH3 L, the

Sync flip-flop sets, producing an active (high) SYNC (1) H input to the BSYNC L bus driver. SYNC (1) H is gated with REPLY (1) H (when active) to produce a direct preset input to the Sync flip-flop. This ensures that BSYNC L will remain active until after the bus slave device terminates its BRPLY L signal and the Reply flip-flop is reset. [REPLY (1) H is low.] The Sync flip-flop then clocks to the reset (BSYNC L, passive) state on the trailing edge of PH3 L.

BWTBT L — BWTBT L is the buffered/inverted control chip WWB H output signal. This signal asserts during PH1 of the addressing portion of a bus cycle to indicate that a write (output) operation follows. It remains active during the output data transfer if a DATOB bus cycle is to be executed.

BDIN L — BDIN L is the inverted, buffered control chip's WDIN H signal. This signal goes active during PH2 following an active RPLY H signal.

BDOU L — The control chip initiates the BDOU L signal sequence by raising WDOU H during PH2. This signal is gated with the passive REPLY (1) L (high) signal to produce an active low D input to the DOU L flip-flop. The flip-flop sets on the leading edge of PH3 H, producing an active BDOU L signal. It clocks to the reset state on PH3 following the REPLY (1) L active (low) signal.

BRPLY L — BRPLY L is a required response from a bus slave device during input or output operations. DIN L and DOUT (1) L are ORed to produce an active I/O L signal whenever a programmed transfer occurs. I/O L enables the time-out counter in the bus error detection portion of the interrupt logic. I/O L is inverted to produce I/O H, which enables the reply gate REPLY H signal input to the control chip.

BRPLY L is received either from the I/SI-H bus or resident memory and inverted to produce a high input to the Reply flip-flop. PH3 H clocks the flip-flop to set state, producing active REPLY (1) H and REPLY (1) L signals. REPLY (1) L is ORed with DMR (1) L to produce an active BUSY H signal. The processor's control chip responds by entering a wait state, inhibiting completion of the processor-generated bus transfer for the duration of REPLY (1) L. REPLY (1) H is gated with I/O H to produce an active REPLY H signal, informing the processor that the output data has been taken or that input data is available on the bus. REPLY H goes passive when I/O H goes passive. The bus slave device will then terminate the BRPLY L signal, indicating that it has completed its portion of the data transfer. On the next PH3 H clock pulse, the Reply flip-flop resets and REPLY (1) H and L and BUSY H go passive.

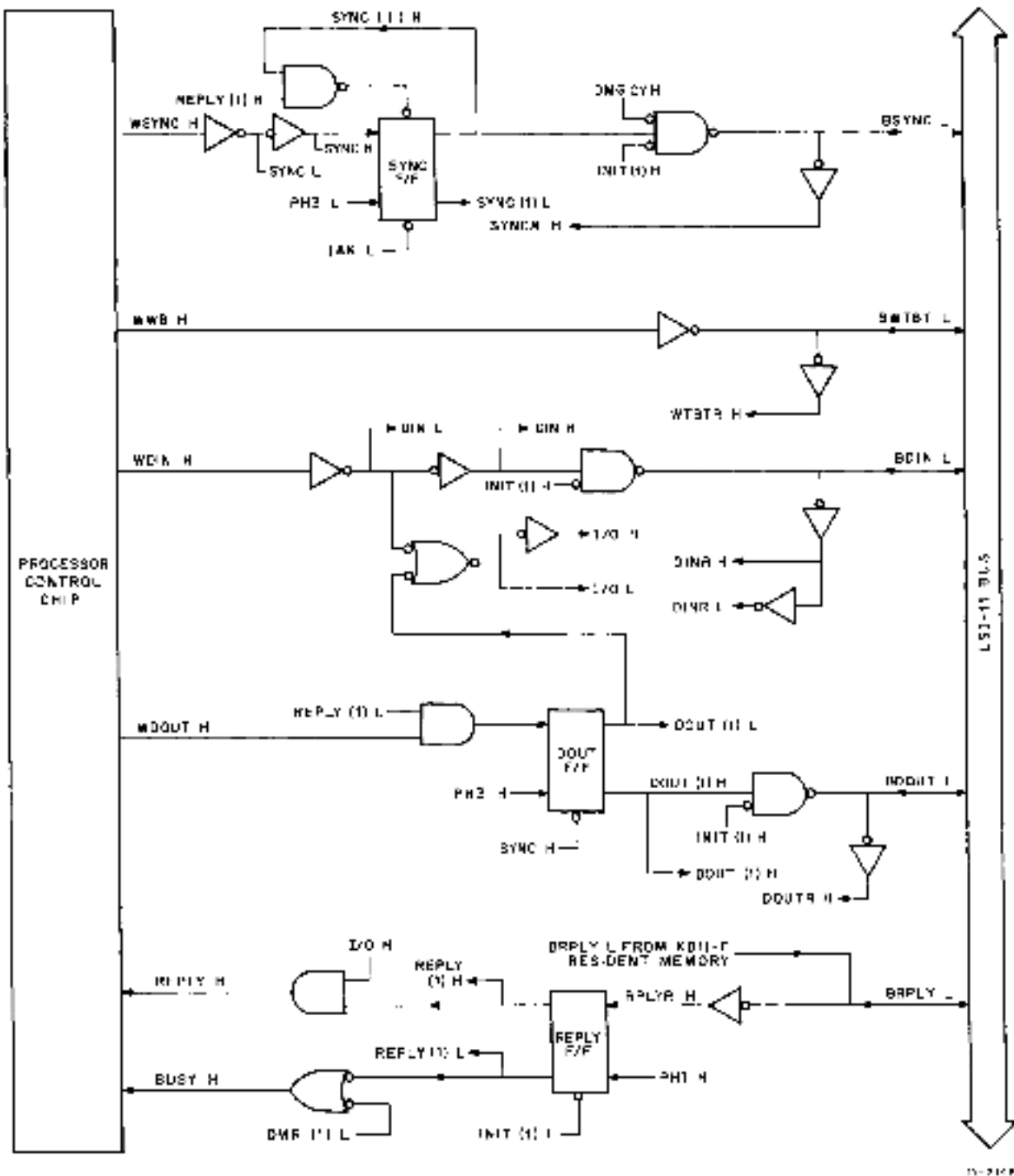

Figure 4-5 Bus I/O Control Signal Logic

4.2.2.5 Bank 7 Decoder—The bank 7 decode circuit is shown in Figure 4-6. Buffers receive WDAL0-15 11 bits and distribute them to the bank 7 decoder and BDAL bus drivers. Bank 7 is decoded during the addressing portion of the bus cycle. If a peripheral device address is referenced, an address in bank 7 (28-32K address space) is used, and WDAL13, 14, and 15 H are

all active (high). This address is decoded and BBS7 L is asserted. When active, BBS7 L enables addressing of nonmemory devices along the bus. During interrupt vector bus transactions, IAK L becomes asserted. IAK L inhibits WDAL15 H, preventing BBS7 L signal generation, which could result in an invalid input data transfer.

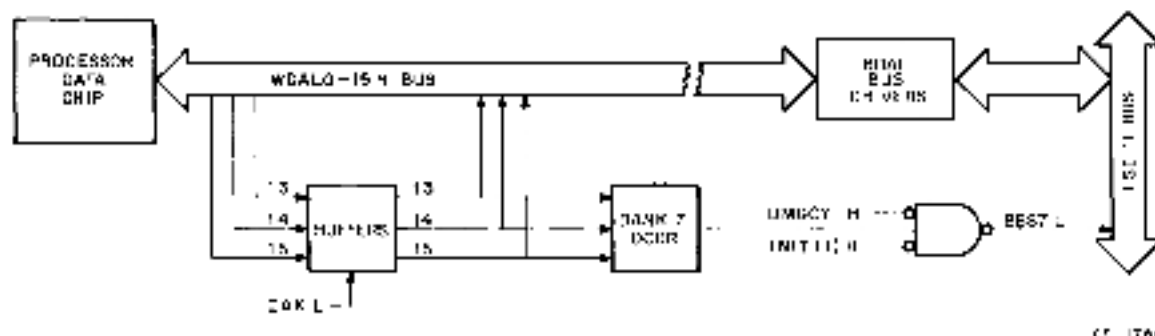

Figure 4-6 Bank 7 Decoder

4.2.2.6 Interrupt Control and Reset Logic — Interrupt control and reset logic functions are shown in Figure 4-7. Reset functions include bus error and power-fail (BDCOK H negated). Interrupt functions include power-fail (impending), Halt mode (console microcode control), refresh interrupt, event (or line time clock) interrupt, and external BIRQ interrupts. The various functions are described in the following paragraphs.

Power-Fail/Restart Sequence—A power-fail sequence is initiated when BPOK H goes low, clocking the Power-Fail flip-flop to the set state. PFAIL (1) L is ORed with HALT L to produce a high signal. This signal is latched during PH2 H, producing an active IPIRQ H (interrupt 1) input to the processor control chip. The processor then interrupts program execution. Note that the low (passive) BPOK H signal is inverted to produce an active PFAIL H input to the fast DIN multiplexer; this signal status is checked by the microcode to ensure that BPOK H is asserted.

Upon entry to this microcode routine, the processor requests a fast DIN cycle. This request is decoded as ROM CODE 15 L, presetting the fast DIN flip-flop. FDIN (0) H goes low, enabling the fast DIN multiplexer to place start-up microcode option jumper data, the passive time-out error [TERR (1) H] signal, and the active PFAIL H signal on WDAL0-3 H. The processor receives the fast DIN information via the data chip. An active PFAIL H signal informs the processor that a power-fail condition is in progress, rather than the halt condition.

If the power failure continues, BDCOK H goes passive (low) and produces an active DC LO L signal, clearing the Power-Fail flip-flop and the power-fail/halt and reset latches and initializing the processor and all devices (Paragraph 4.2.2.1). The active RESET L signal then initializes the processor, causing it to abort console (halt) or power-fail microcode execution and enter a "no operation" state. The processor remains in this condition until BDCOK H returns to the active state.

The power-up restart condition occurs when DC LO L goes false; RESET L goes passive (high) on the next PH2 H clock pulse. The processor responds by executing a fast DIN cycle to determine the start-up microcode option jumper configuration. Once the fast DIN cycle has been completed, the processor executes the power-up option selected, and normal operation resumes when BPOK is asserted.

Halt Mode — The Halt mode is entered either by executing the HALT instruction or by a device asserting the BHALT L signal. The processor halts program execution and enters microcode execution as described for a power-fail operation. However, when the processor executes the fast DIN cycle, the PFAIL H bit (WDAL3 H) is not active and console microcode (not a power-fail sequence) is executed. Negation of BHALT L will allow the processor to resume PDP-11 program execution. On the next PH2 H clock pulse, IPIRQ H goes false (low) and the processor Run mode is enabled.

clock pulse signals. Normally BRPLY L would be asserted, producing an active REPLY (1) H signal which inhibits the counter; the count would remain stable until cleared by a passive I/O L signal. However, if BRPLY L is not received within 10 μ s, the full count (02₁₆) is attained. This is the error condition; TERR L goes low and TERR (1) H goes high. The next PH2 H clock pulse clocks the reset latch to the reset (active) state, producing an active RESET L signal. The processor responds by executing the reset microcode. After entering the microcode, the processor executes a fast DIN cycle and determines that a time-out (bus) error TERR (1) H, rather than a power-fail condition, has occurred. It then responds by executing the bus error trap service routine. TFCLR L (ROM code 2) is generated by the processor to clear the TERR latch.

Normal I/O Interrupts — "Normal" I/O interrupts are those interrupt requests which are generated by external devices using bus interrupt request BIRQ L. The request is initiated by asserting BIRQ L. This signal is inverted to produce a high signal, which is stored in the interrupt request latch on the next PH2 H pulse. The stored request produces TORQ H, which informs the processor of the request. If processor status word priority is 0, the processor responds by producing an active WIACK H (interrupt acknowledge) and WDINH signals. WDINH is buffered onto the BDIN L signal line to signal devices to stabilize their priority arbitration. WIACK H is inverted, producing IACK L, setting the Interrupt Acknowledge flip-flop on the trailing edge of PH1 L one cycle after BDIN L is asserted. The high (active) interrupt acknowledge signal is enabled onto the BIAKO L signal line by passive (low) DMGCY H and INIT (1) H signals. The highest priority device requesting interrupt service responds to the processor's BDIN L and BIAK L signals by placing its vector on the BDAL bus and asserting BRPLY L, inputting its vector to the processor. Note that BSYNC L is not asserted during this operation and that no device addressing occurs. The device also clears its BIRQ L signal. The processor responds to BRPLY L by terminating BDIN L and BIAK L.

Refresh — Memory refresh is initiated by a 600 Hz refresh oscillator. This function is enabled when jumper W4 is not installed. The leading edge of RFOSC H clocks the Refresh Request flip-flop to the set state. On the next PH2 H clock pulse, the memory refresh request latch stores the request and applies an active RFIRQ H signal to the processor's control chip. The processor responds by producing an active RFSET L signal and executing the refresh microcode. RFSET L sets the Refresh flip-flop, producing the BREF L signal (Paragraph 4.2.2.7) and clearing the Refresh Request flip-flop, which terminates the request.

TFCLR L resets the Refresh flip-flop when the refresh operation is completed. Note that BREF is not asserted if DMGCY H or INIT (1) H is asserted.

Event Line Interrupt — The event line interrupt function can be used as a line time clock interrupt, or as desired by the user. This interrupt differs from the normal I/O interrupt request by being the highest priority external interrupt, and it does not input a vector in order to enter its service routine. The interrupt is initiated by the external device by asserting BEVNT L. This signal is inverted to produce a high (active) signal, which clocks the Event flip-flop to the set state. (Note that when W3 is installed, the flip-flop remains reset and the event function is disabled.) On the next PH2 H clock pulse, the event interrupt request latch stores the active EVNT (1) H signal. An active EVIRQ H signal is then applied to the control chip. If processor status word priority is 0, the interrupt will be serviced. Service is gained via vector (00)₂, which is dedicated to the event interrupt. Hence, a bus DIN operation does not occur when obtaining the vector. The request is cleared by the microcode generated EICLR L signal.

4.2.2.7 Special Control Functions — Special control functions include microcode-generated bus initialize and memory refresh operations and five special control signals which are internally on the processor module. Special control function logic circuits are shown in Figure 4-8. Microinstruction bus lines WMIB18-21 L are buffered to produce the four SROM0-3 H signals. The actual codes for the special functions are contained on SROM0-2 H; SROM3 H is always active when a special function is to be decoded, enabling the 1 of 8 decoder during PH3 H. The resulting decoded functions are described below.

ROM Code 10 — Not used.

ROM Code 11 [IFCLR and SRUN L] — This code is produced by the processor to clear the Initialize flip-flop and to assert the SRUN L signal for a RUN indicator in PDP-11/03 systems.

ROM Code 12 [TFCLR L] — This code is a trap function clear signal which clears the Refresh Request and Time-Out Error flip-flops (Paragraph 4.2.2.6).

ROM Code 13 [RFSET L] — This code is used to set the Refresh flip-flop. The active (high) flip-flop output is gated with passive (low) INIT (1) H and DMC (1) H signals to produce the active BREF L signal. The flip-flop normally resets by the microcode-generated TFCLR L signal after completing the refresh operation, or whenever a power failure occurs. (DC LO L goes active and clears the flip-flop.)

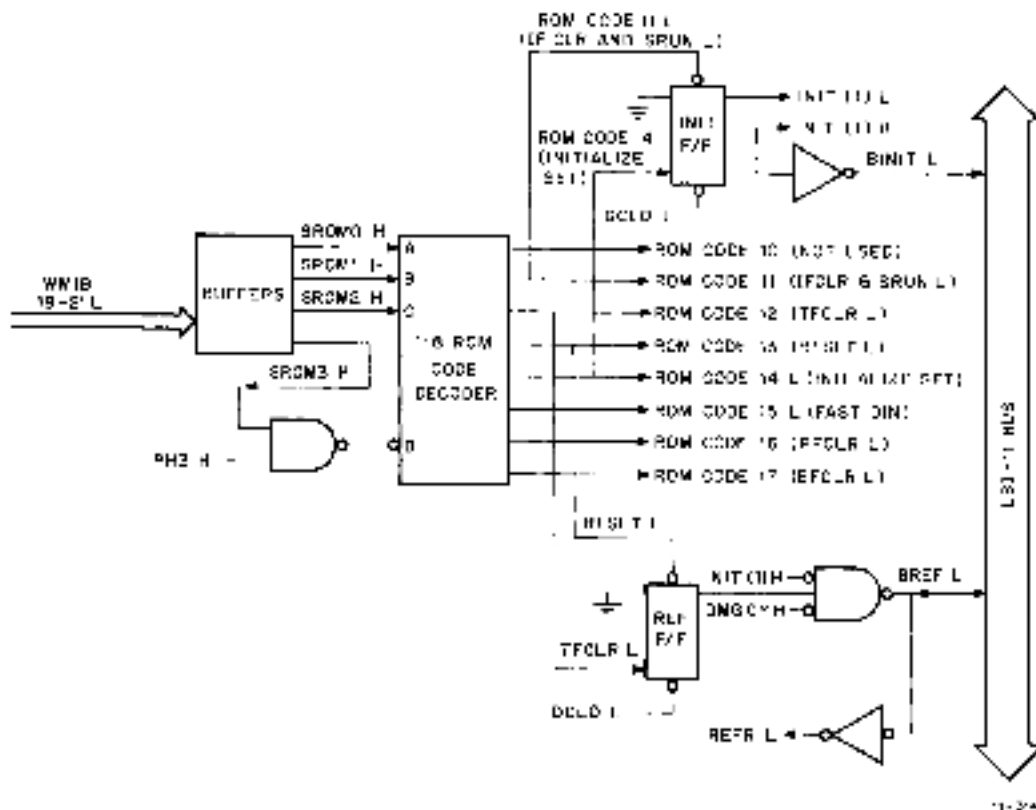

Figure 4-8 Special Control Functions

ROM Code 14 [Programmed Initialize] — A programmed LSI-11 bus initialize operation can be performed by executing the RESET instruction. The processor responds by generating ROM Code 14 L (decoded). On the positive-going trailing edge of this signal, the Initialize flip-flop clocks to the reset (active) state, producing the active initialize signal. Approximately 10 μ s later, the processor produces a TFCLR L signal, clearing the initialize signal.

During a power failure, the active DC LO L signal is distributed to the Initialize flip-flop clear input; when cleared, the flip-flop is in the active state and INIT (1) H, INIT (1) L, and BINIT L initialize signals are used to clear (or initialize) all LSI-11 system logic functions. When normal power resumes, the processor microcode terminates the initialize cycle by generating TFCLR L, presetting the Initialize flip-flop: this is the passive (noninitialize) or normal flip-flop state and all initialize signals return to their passive states.

ROM Code 15 [Fast DIN Cycle] — The processor generates this code when a fast DIN cycle is required.

The fast DIN cycle allows the processor to read (input) the selected start-up mode, time-out error, and power fail signal status (Paragraph 4.2.2.6).

ROM Code 16 [PFCLR L] — This code clears the Power Fail flip-flop (Paragraph 4.2.2.7).

ROM Code 17 [EFCCLR L] — This code clears the Event flip-flop (or line time clock interrupt request) (Paragraph 4.2.2.7).

4.2.2.8 Bus Arbitration Logic — Bus arbitration logic (Figure 4-9) enables the LSI-11 bus to be used by DMA devices or the processor. The device (or processor) controlling the bus is called the bus master. When no DMA requests are pending, the processor is bus master and all data transfers are programmed. When a DMA device is bus master, processor operation is suspended until the DMA operation is finished.

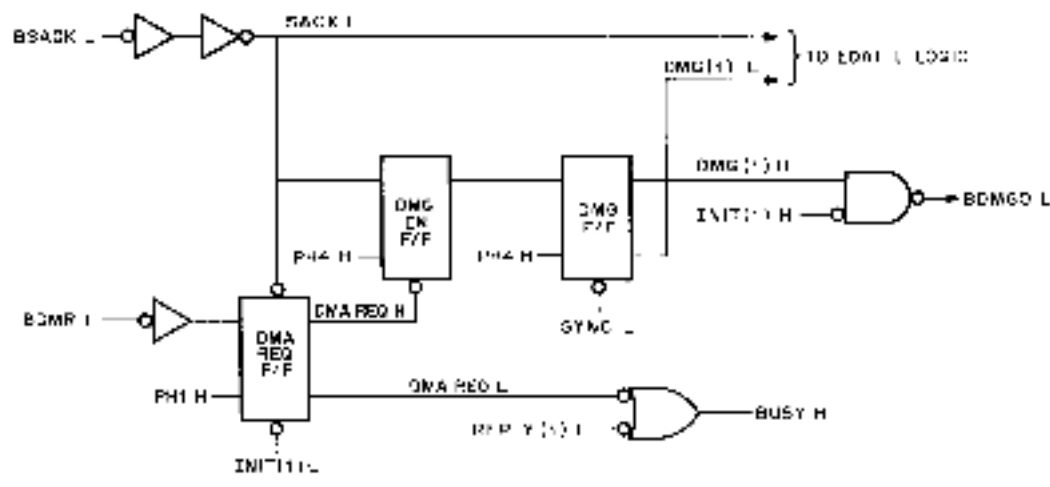

Figure 4-9 Bus Arbitration Logic

Prior to a DMA request, the DMA Request flip-flop is reset (Figure 4-10); the DMA REQ H signal is passive (low), clearing the DMG Enable flip-flop. A device initiates a DMA request by asserting BDMR L. The request is inverted to produce a high signal, which is clocked into the DMA Request flip-flop on the next PH1 H clock pulse, producing active DMA REQ H and L signals. DMA REQ L is ORed with REPLY (1) L, producing BUSY H and causing the processor to "wait" after completing its present bus cycle. On the leading edge of PH4 H, the stored DMA request sets the DMG Enable flip-flop. The processor is finished with its present bus cycle and releases the bus when SYNC L goes passive (high).

On the first PH4 H clock pulse following the passive state of SYNC L, the DMG flip-flop clocks to the set state and DMG (1) H and DMG (1) L go to their active states. DMG (1) H produces the active BDMG grant (BDMGO L) signal. DMG (1) L enables EDAL L signal generation when the DMA operation involves KD11-F resident memory. The DMA device responds to the BDMG signal by negating BDMR L and asserting BSACK L, enabling EDAL L signal generation and keeping the DMA Request flip-flop in the set state. On the first PH4 H clock phase following the active state of BSACK L, the DMG Enable flip-flop clocks to the reset state and DMG EN H goes low. The following PH4 H clock pulse clocks the DMG flip-flop

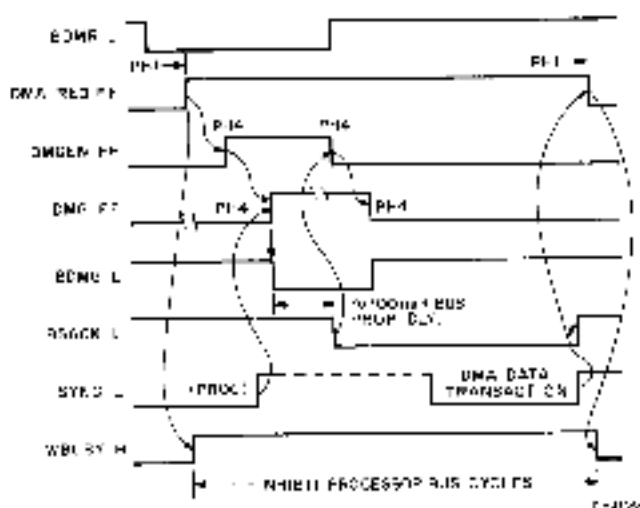

Figure 4-10 DMA Grant Sequence

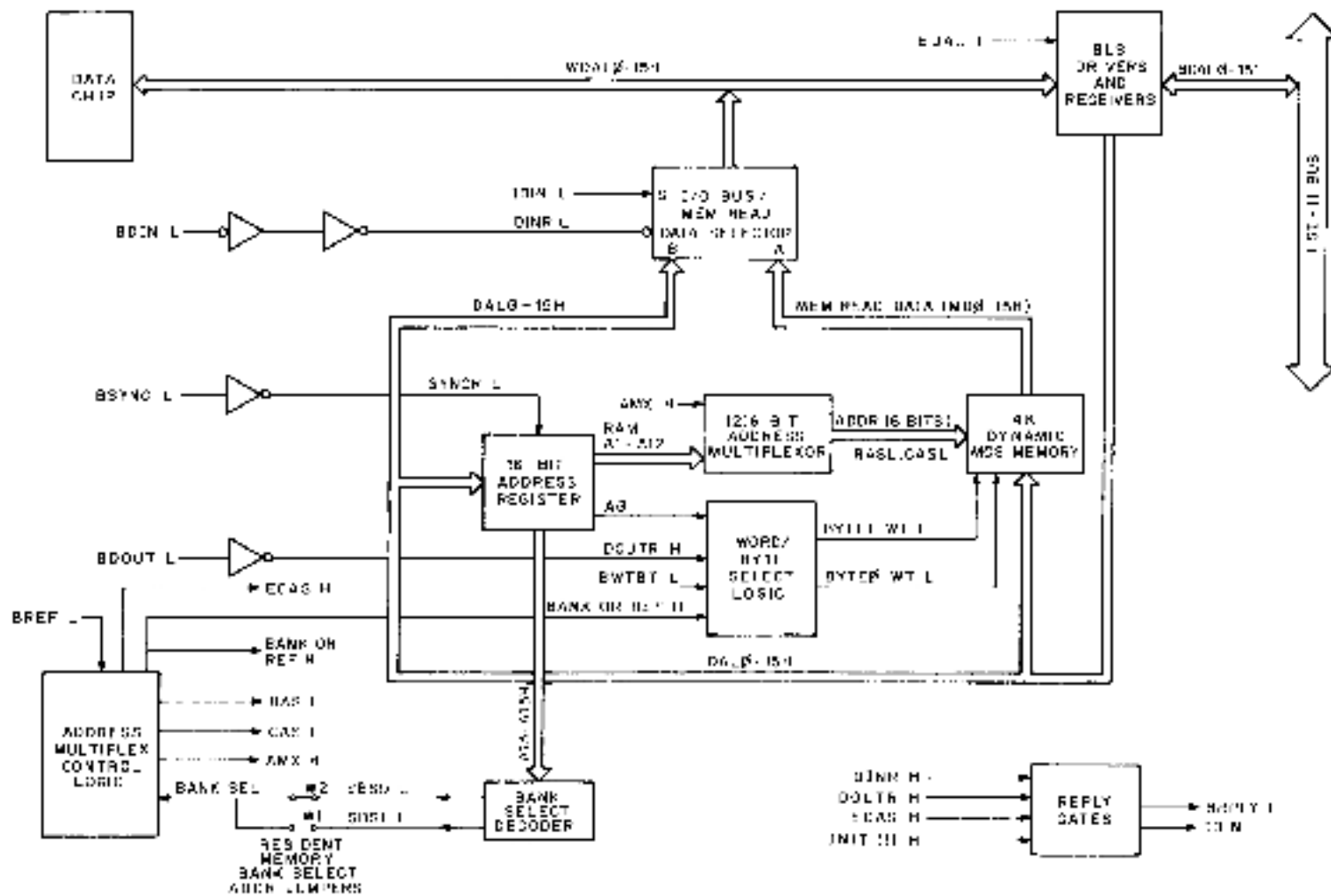

Figure 4-11 KD11-F Resident Memory

to the reset state and **BDMGO J** goes passive (high), terminating the DMA request/grant sequence. **BSACK L** remains asserted for the duration of the DMA operation, preventing new DMA requests from being arbitrated.

The DMA device releases the bus by terminating **BSACK L**. The following **PHI H** clock pulse clocks the DMA request flip-flop to the passive state. **BUSY H** then goes passive, enabling a processor-initiated bus cycle. Once the processor-initiated cycle is entered, **SYNCL J** inhibits (clears) the DMG flip-flop for the duration of the processor's present bus cycle.

4.2.3 KD11-F Resident Memory

The 4K by 16-bit dynamic MOS read/write memory is included on the KD11-F processor module only. (KD11-J basic memory is magnetic core, which is contained on a separate MMV11-A core memory unit.) Resident memory can reside in either the first or second 4K address bank. One of two jumpers can be installed on the module to select the desired bank (bank 0 or 1).

The basic functions involving the resident memory are shown in Figure 4-11. Resident memory comprises sixteen 4K by 1-bit memory chips, addressing, and control logic. The memory chips, which are 16-pin devices, require an address multiplexer to address the chips with two 6-bit bytes. The complete addressing, write, and read operations are described below.

Addressing is initiated by a master device — either the LSI-11 processor or a DMA device — by placing the 16-bit address on **BDAL0-15 L** and asserting **BSYNCL L**, latching the address in the 16-bit address register. Note that the resident memory address will appear on the **BDAL** bus even when the processor is bus master; the resident memory functions exactly as a memory located elsewhere along the LSI-11 bus. Address bits are routed via **BDAL** bus receivers onto the processor module's **DAL0-15 H** bus to the address register input. Stored address bits **A13—A15 H** are then decoded by the bank select decoder. **SBS0 L** (bank 0) and **SBS1 L** (bank 1) will go active (low) only when their respective bank addresses are decoded. **W1** or **W2** then applies the selected address to the address multiplex control logic, enabling the resident memory response. Address multiplex logic immediately generates an active row address strobe (**RAS**), which remains active for the duration of the **BSYNCL L** signal. Address multiplex control (**AMX**) is initially high, multiplexing the stored

row address (bits **A7—A12 H**) through the 12:6-bit address multiplexer and into all memory chips. After 150 ns, address multiplex control logic generates an active column address strobe (**CAS**) and a low **AMX** signal. The multiplexer output bits (**A1-A6**) are then strobed into all memory chips, completing the addressing portion of the memory operation.

When in a memory read operation, each of the 16 memory chips places an addressed bit on the memory read data bus. This data is multiplexed via port A of the I/O bus/memory read data selector only when in a resident memory read (or refresh) operation; the select input of the data selector is asserted low for this data selection. The read data is then placed on **WDAL0-15 H**, where it can be read by the microprocessor data chip or gated onto the **BDAL** bus via bus drivers for input to a DMA device.

When in a memory write operation, the addressing portion of the operation is similar to the read cycle addressing, except **BWTBTL L** may be asserted by the master device to indicate that a write operation is to follow. After the addressing portion of the cycle has been completed, **BWTBTL L** either goes passive (high) if a **DATO** (word) write cycle is to be performed, or remains asserted (**BWTBTL L** remains low) if a **DATOB** (byte) write cycle is to be performed. Word/byte select logic responds to the **DATO** cycle by asserting both **BYTE 0 WTL** and **BYTE 1 WTL** for the duration of the cycle, enabling **DAL0-15 H** data bits into the addressed location in all memory chips. However, when in a **DATOB** cycle, only one active signal is produced, depending upon the state of the stored byte pointer (address bit **A0**). If **A0** is low (even byte), only **BYTE 0 WTL** goes active, enabling only **DAL0-7 H** bits to be written into the addressed location in the appropriate eight memory chips. Similarly, if **A1** is high (odd byte), only **BYTE 1 WTL** goes active, enabling only **DAL8-15 H** bits to be written into the addressed location in the appropriate eight memory chips.

Resident memory, as well as any LSI-11 bus device, must respond to any data transaction by generating an active **BRPLY L** signal. Reply gates provide this function. Approximately 150 ns after **CAS L** goes true (as previously described), the reply gates are enabled; the gates will respond to either an active **BDIN L** or **BDOUT L** signal by asserting **BRPLY L**. Reply gates are inhibited during an initialize operation.

Resident memory requires a refresh operation once every 1.6 ms. This operation is entirely under the control of either processor microcode or an external DMA device, as selected by the user. Resident memory responds to $\overline{\text{BREF}}_L$, generated by the refresh-controlling device, by simulating a "bank selected" operation. (All memory banks are simultaneously refreshed.) Refresh is then accomplished by executing 64 successive $\overline{\text{BSYNC}}_L/\overline{\text{BDIN}}_L$ operations while incrementing $\overline{\text{BDAL}}_{1-6}_L$ by one location on each bus transaction. Refresh is simply a series of forced memory read operations where only the row addresses are significant. Each of the 64 rows in all dynamic MOS memory chips in an LSI-11 system are simultaneously refreshed in this manner.

4.2.4 DC-DC Power Inverter

The dc-to-dc power inverter circuit provides on-board generation of required negative dc voltages. Input dc power for the inverter circuit is obtained directly from the +12 V input. The inverter switching rate is clocked by the clock pulse generator's $\overline{\text{DIVB}}(0)_{11}$ 2.8 MHz output. Output negative dc voltages are distributed to all resident memory chips. The -5 V output is distributed to microprocessor chips (data chip, microm chips, and control chip).

4.3 MMV11-A 4K BY 16-BIT CORE MEMORY

4.3.1 General

The MMV11-A 4K by 16-bit core memory option provides nonvolatile read/write storage of user programs and data. Memory 4K addressing is user-selected by

switches contained on the option. The MMV11-A is completely LSI-11 bus compatible and capable of either programmed I/O data transfers with the processor or transfers with another LSI-11 DMA bus device.

The MMV11-A features:

- 4096 by 16-bit capacity
- Typical access time = 425 ns (475 ns maximum); full read/restore cycle time = 1.15 μ s.
- Nonvolatile read/write storage — stored data remains valid when power is removed.
- User-selected bank address — three switches allow the user to select the bank address for the option.
- 15 V and +12 V power — only the normal backplane power is required to power the option.
- No adjustments, no periodic maintenance.

The MMV11-A is contained on two modules which are mated to comprise a single assembly as shown in Figure 4-12. The modules include memory interface and timing board (module type G653) and core stack (module type H223). The actual size of the assembly is 8.5 by 10 by 0.9 in. The G653 module includes handles and retractors on the top edge and fingers on the bottom edge which plug into the LSI-11 bus. Circuits contained on this module include interface, control and timing logic, bus receivers and drivers, the 16-bit data paths, sense amplifiers, and a -5 Vdc to 5 Vdc

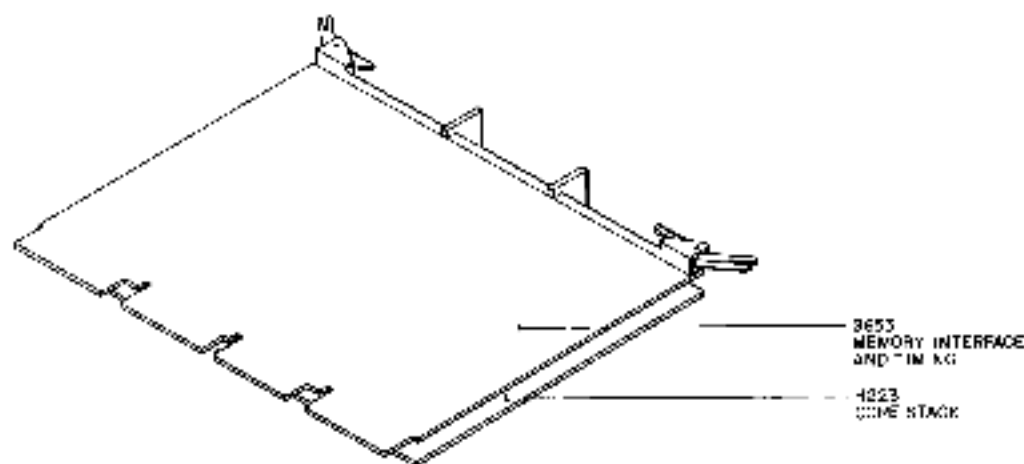

CP-1731

Figure 4-12 MMV11-A Core Memory Option

inverter. The H223 module is slightly smaller, includes no handles or bus fingers, and plugs onto the No. 2 (solder) side of the G653 module via special connector pins. Spacers are located between the modules to stiffen the assembly and to maintain the 0.9 in. dimension. Circuits contained on the H223 module include the 4096 by 16 core stack, 12-bit address register, X and Y drives, stack charge, temperature compensation, and a series +11 V. Vcc switch which removes drive power when BDCOK H goes low (power fail) or BINIT L is asserted.

4.3.2 Functional Description

4.3.2.1 Introduction — The MMV11-A memory is a read/write, random access, coincident current magnetic core type with a cycle time of 1.15 μ s and an access time of 425 ns. It is organized in a 3D, 3-wire planar configuration. Word length is 16 bits and the memory consists of 4096 (4K) words.

Major functions contained in the MMV11-A are shown in Figure 4-13. Memory data can be stored (written) or read by executing appropriate bus cycles: DATO (16-bit word) write; DATOB (8-bit byte) write; DATI (16-bit word) read; DATIO (16-bit word) read-modify-write; and DATIOB (16-bit word) read-modify-(8-bit byte) write.

Each of the functions shown in Figure 4-13 is briefly described below:

Bus Receivers and Drivers — These devices interface directly with the LSI-11 bus and the G653 logic circuits. BDAL bus drivers are gated on by DATA OUT L during a read operation (DATI or the input portion of a DATIO(B) bus cycle).

Bank Decoder — The bank decoder receives address bits A13-15 L and responds when the bank address is as user-selected on the three bank address switches on the G653 module. It responds by producing an active DSEL H signal which initiates memory cycle timing. This signal is enabled only when power is normal and bus initialize or refresh operations are not in progress.

Timing and Control — Timing and control circuits receive bus and internal control signals and generate appropriate read/write timing and control signals. It also generates the RRPLY L signal in response to BDIN L and BDOUT L.

Address Register — The address register stores the 12-bit word address within the 4K bank during the addressing portion of the bus cycle. Latched bits

LA1—611 are applied to Y drive circuits and LA7—1211 are applied to X drive circuits.

X and Y Drives — X and Y drive circuits control X and Y read/write currents through all core mats. Address decoding activates 1 out of 64 X wires and 1 out of 64 Y wires. Because the active X and Y wires each have one-half the current required for core saturation, only one core out of 4096 cores in each core mat is saturated. Direction of current is determined by a read or write operation.

Core Stack — The core stack comprises sixteen 4096-core mats. Each mat is associated with one memory bit position at all 4096 locations. Each core has three wires passing through it: one X, one Y, and one sense/inhibit wire. The sense/inhibit wire passes through all 4096 cores in one mat. Hence, the stack contains 16 sense/inhibit lines.

The sense/inhibit line ends terminate at sense amplifier inputs. During a write operation, an inhibit current, equal to saturation current, is applied to the center of the sense/inhibit line when a logical 0 is to be written in the addressed core. This current splits and one-half saturation current flows through all cores in the mat and into termination diodes at the sense amplifier inputs. The wire is threaded through the cores in a manner that causes the current to flow in a direction opposite to that of the Y write current; this prevents core saturation, which would write a logical 1 in the addressed core.

Sense Amplifiers — Sense amplifiers respond to induced voltage impulses during the read cycle. They are strobed during a critical time of the cycle, producing an active (high) output when a logical 1 is read, regardless of the induced polarity on the two ends of the sense/inhibit wires for each bit.

Inverters — The inverters receive sense amplifier outputs, invert them, and direct-set previously cleared memory data register bits when a logical 1 is sensed.

Memory Data Register — The 16-bit memory data register is cleared upon entry to a read cycle; sensed logical 1s set appropriate bits. During a restore cycle (DATI bus cycle) (no memory contents are to be modified), the same bits (low-active) are written into the same addressed location. During a write cycle (DATO, DATOB, or the write portion of a DATIO(B) bus cycle), bus data bits are clocked into the high and/or low byte(s), (depending upon the type of bus cycle (word or high byte or low byte)).

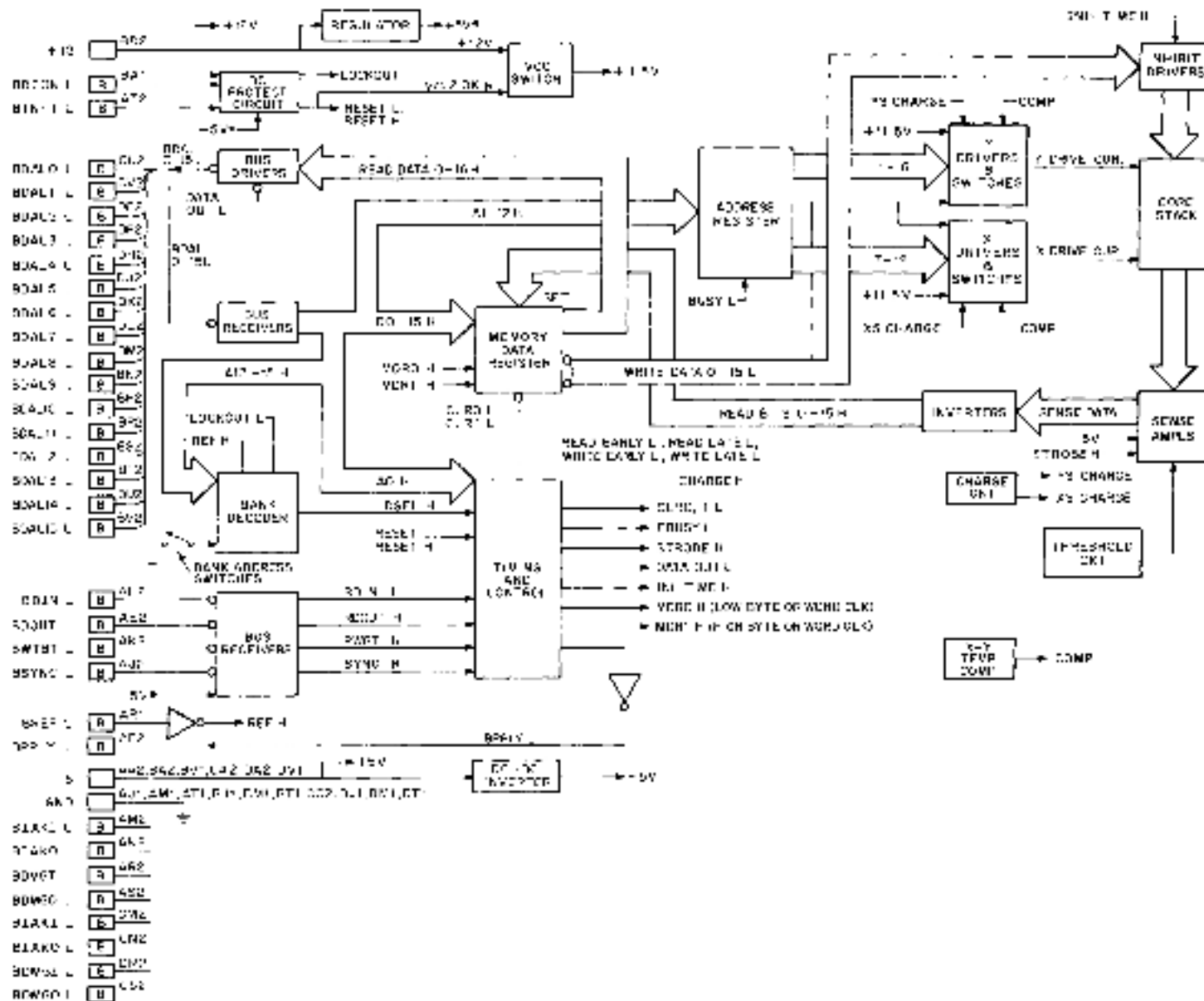

Figure 4-13 MMV11-A Logic Block Diagram

Inhibit Drivers — Inhibit drivers, one for each bit position, produce an inhibit current during the write cycle at **INH TIME H** if a logical 0 is to be written. The current inhibits core saturation, which would produce a stored logical 1.

Charge Circuit — The charge circuit applies the correct operating voltage to **X** and **Y** drive circuits during the read and write memory cycles to prevent "sneak" currents through unselected stack diodes.

X—Y Temperature Compensation — **X—Y** temperature compensation circuits alter drive currents over the required operating temperature range to provide reliable operation.

DC—DC Inverter — The dc—dc inverter circuit generates -5 V power for sense amplifiers from the -5 V power.

DC Protection — DC protection circuits respond to an active **BNIT L** or passive **BDCOK H** signal by producing active **LOCKOUT L**, **RESET H**, **RESET L**,

and passive **VCC2OK H** signals. These signal conditions prevent memory circuit operation and the possible loss of stored data.

Vcc Switch — The Vcc switch applies +11.5 V to **X** and **Y** driver circuits when not in an initialize or power fail condition.

4.3.2.2 Core Addressing — When a memory location is addressed, one core in each of the 16 mats are accessed for a read or write operation. Figure 4-14 illustrates a portion of the **X—Y** drive and associated circuits for one **Y** wire. Six address bits (**A1—A6**) select 1 of 64 **Y** wires. A similar circuit (not shown) involving the remaining six address bits (**A7—A12**) selects 1 of 64 **X** wires. Hence, by placing 64 cores (in each mat) on each **Y** wire and passing a different **X** wire through each core, one of 64 cores on the active **Y** wire will be selected. Since the remaining **Y** wires have a similar 64 cores each and receive the same **X** wires, 64 × 64, or 1 out of 4096 addressing is accomplished in each of the core mats. A single **Y** wire is driven as described below.

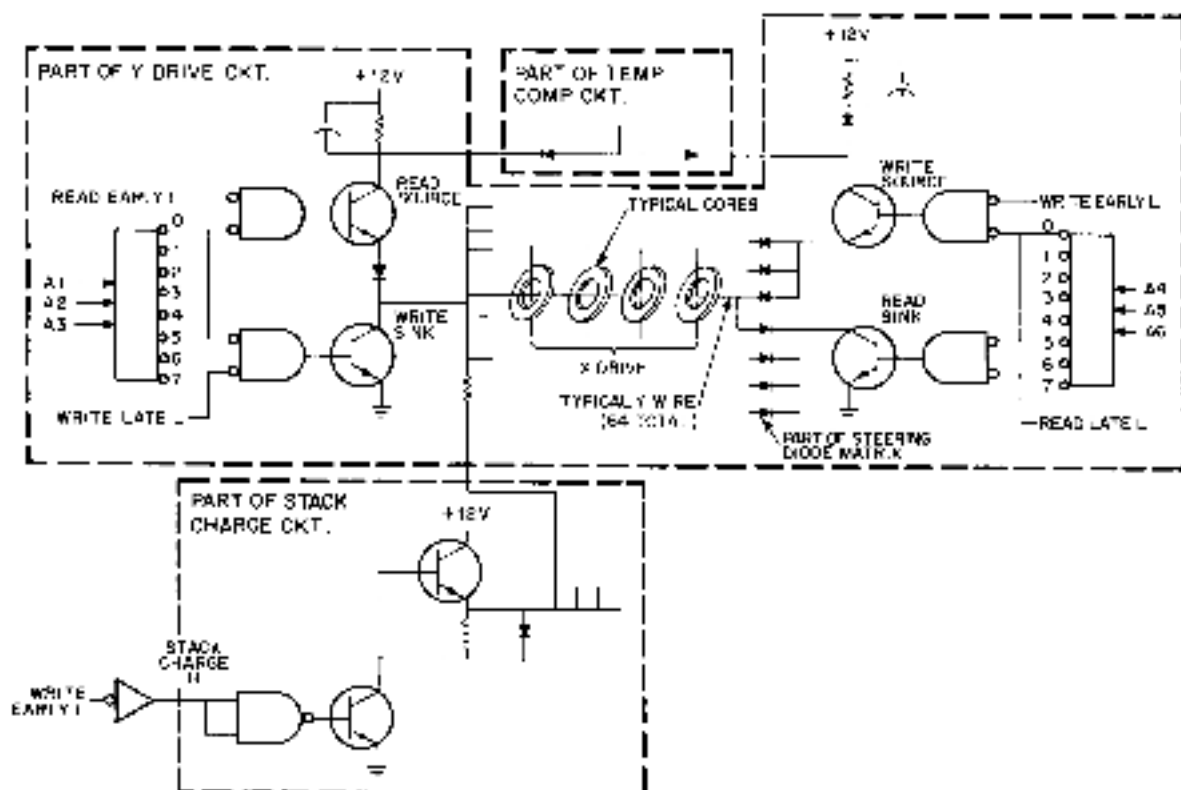

CP-283

Figure 4-14 MMV11-A Core Addressing

Two 1:8 (octal) decoders are used in Y wire selection, each receiving three address bits from the address register. Only one output from each decoder will be active during addressing. Assuming address XX00 (the zeros are the Y portion of the 12-bit address), the portion of the Y drive circuit shown will be enabled. During a read operation, READ EARLY L goes active and turns on one of the eight read current source transistors. A diode in its emitter circuit couples the drive to eight Y wires, each terminating at the diode steering matrix. The diodes provide a read current path to all eight read sink transistors. READ LATE L goes active 25 ns after the Y source is turned on, and turns on one of the eight read sink transistors, completing a read current path to ground. Hence, 1 of 64 Y wires is selected, producing a read half-current through 64 cores in all memory mats. Similar X drive circuits will produce an X read half-current in 64 cores in each mat in exactly the same manner. Only one core in each mat will receive an X and a Y read half-current, causing the core to saturate in the 0 state. If the core was previously in the 1 state, a voltage pulse will be induced in the sense/inhibit wire as it switches to the 0 state.

A write cycle is always preceded by a read cycle. The write operation is similar to the read operation, except write current flows through the addressed wire in a direction opposite to the read current direction. The core in each mat receiving X and Y write half-currents will respond by saturating in the 1 state. However, since a 0 may be desired, a third wire (sense/inhibit) will conduct a half-current which opposes the magnetizing effect of the Y write currents. Thus, core saturation is not attained and the cores where 0s are written remain saturated in the 0 state from the previous read cycle.

Temperature compensation is applied to driver circuits via a source current, which is inversely proportional to temperature; an increase in temperature decreases available drive current.

The stack charge circuit applies a +11 V (approximately) signal to the sink ends of all X (not shown) and Y wires during the write cycle. The level is applied during WRITE EARLY time. Since WRITE LATE L occurs 25 ns after WRITE EARLY L, the write sink transistor is cut off, and the full 11 V signal charges the stray capacitance of the X-Y lines, reducing the capacitive delay effect as the X and Y write source transistors turn on; the 11 V signal also reverse biases diodes not selected by addressing circuits, preventing sneak currents. The addressed sink transistor, turned on by the active WRITE LATE L signal, provides the

return path for the selected X and Y wires; only those two wires will go to approximately 0 V, causing one X and one Y diode to become forward biased, enabling the write half-currents to flow. Resistors coupling the charge voltage to write sink transistors limit the charge current through the addressed write sink transistors during the remainder of the write cycle. This circuit performs the same function for read cycles by grounding the buses and preventing sneak currents through unselected stack diodes.

4.3.2.3 Read/Write Data Path — The basic read/write data path is shown in Figure 4-13. Upon entering a read cycle, the memory data register is cleared by CLR0 L and CLR1 L. X and Y read currents produce active sense amplifier outputs for those cores containing stored (logical 1s as they are switched to the 0 states. These signals are inverted and applied to the direct-set inputs of the flip-flops comprising the memory data registers, setting the appropriate bits. During a write cycle, CLR0 L (DATOB low byte address), or CLR1 L (DATOB high byte address), or both CLR0 L and CLR1 L (DATO word address) clear the previously read data. The bus data is then received and clocked into the register flip-flops by CLK MDR0H and/or CLK MDR1H, as appropriate. Write data bits are then routed to inhibit drivers which inhibit writing 1s when write bits are 0s (high). Inhibit half-current through addressed cores prevents X-Y write half-currents from switching cores to the 1 state.

The sense/inhibit wire passes through all cores in a core mat, as shown in Figure 4-15. The circuit shown in the figure is repeated for each of the 16 core mats. During the read portion of a memory cycle, a logical 1 stored in the addressed core will cause an induced voltage to appear on the sense/inhibit wire as the core switches from the 1 saturation state to the 0 saturation state. If a 0 was previously written, no appreciable voltage is produced since the core is already saturated in the 0 state. During the read operation, the sense/inhibit wire functions as a loop whose ends terminate at the sense amplifier inputs. Any difference in potential (either polarity) will enable a sense amplifier output. STROBE H occurs during X and Y drive read currents at a critical time (the time of peak core switching output when 1s are read). Thus, only the correct voltage pulse produced when a core goes from the 1 state to the 0 state is gated into the Memory Data Register flip-flop.

The threshold circuit establishes the signal voltage level at which a logical 1 is read during strobe time. A signal voltage magnitude greater than approximately 17 mV during strobe time results in a valid 1 level.

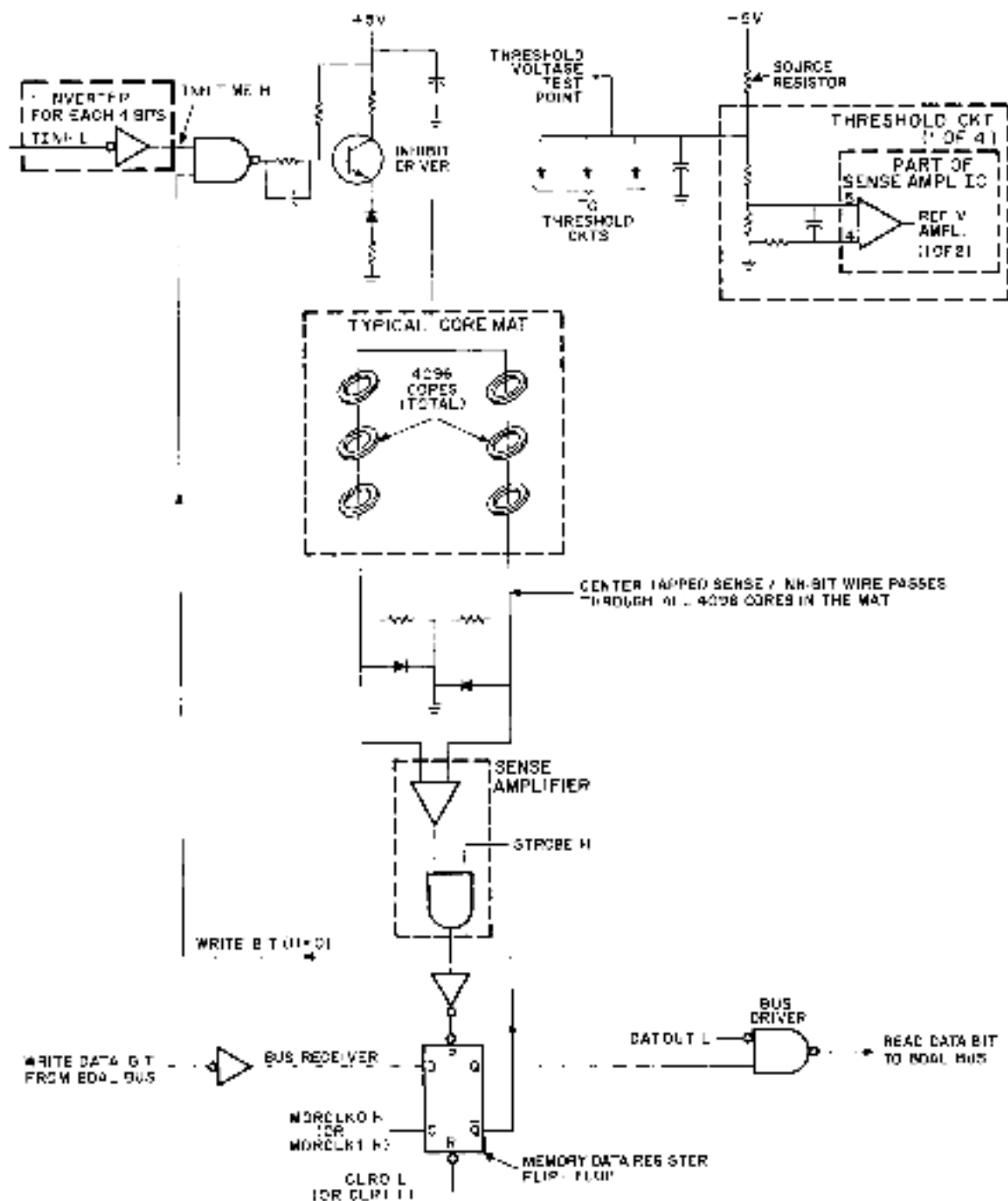

Figure 4-15 MMV11-A Read/Write Bit Data Path

Signal levels less than the 17 mV threshold value are considered invalid and result in 0 levels being read. Four threshold circuits share a common source resistor. Each threshold circuit provides a reference amplifier input voltage to two sense amplifier ICs, each containing two sense amplifiers; hence, one threshold

circuit provides a threshold voltage for four data bits.

When in the write portion of the memory cycle, the inhibit driver remains off if a 1 write data bit is stored in the memory data register flip-flop. However, if a 0 is to be written, the write bit is high, enabling a gate input

for the inhibit driver. At **INH TIME H** during the write cycle, the inhibit driver produces an inhibit current equal to core saturation in a direction that would produce a logical 0. However, note that the inhibit current is applied to the center of the sense/inhibit wire. Thus, half-currents flow into each half of the sense/inhibit wire, preventing the addressed core from saturation in the 1 state. Diodes at the sense amplifier ends of the wire provide a ground return for the two inhibit half-currents. The two resistors terminate the ends of the wires. The inhibit driver transistor collector is clamped to ground through a diode and resistor to prevent breakdown during turnoff. The emitter resistor limits peak current.

4.3.2.4 Timing and Control—All memory bus cycles comprise a read and a write operation. During a **DATI** bus transaction, a memory read-restore cycle is executed. The data is first read and placed on the **I/O** bus. The same data is then written in the same addressed location. During a **DATO** bus transaction, a memory read-modify-write cycle is executed. After reading the contents of the addressed location, bus data is clocked into the memory data register. Previously read data is lost. The modified word is then written into the addressed location during the remainder of the cycle. If a **DATOB** bus transaction is being executed, only an 8-bit portion of the memory data register is modified, and one byte of the previously read word is retained for the write operation. A **DATIO** bus transaction actually initiates two separate memory cycles. The first cycle (read-restore) is initiated by the master device by placing the memory address on **BDAL0—15 L** and asserting **BSYNC L**. After receiving and modifying the memory read data, the master device outputs the new data to the memory and asserts **BDOUT L**, which initiates the next memory cycle (read-modify-write). Timing and control logic functions generate all of the timing and control signals for the memory cycles described above. Logic operation for each type of bus transaction is described in detail in the following paragraphs.

A memory cycle is initiated when the correct bank address asserted by the bus master device is decoded on the leading edge of **BSYNC L**. **DSEL H** is the decoded bank address signal; note that it is inhibited during refresh bus cycles (when **BREF L** is asserted), or when an initialize or power fail condition exists. The logical state of **DSEL H** is clocked in the Busy flip-flop on the leading edge of **SYNC H** (Figure 4-16). When **DSEL H** is active (high), the Busy flip-flop sets and **FBUSY H** and **FBUSY L** go to their true states. **FBUSY L** enables one input of the read initiate gate. The remaining gate input is enabled by the negative-going pulse produced

by the RC circuit connected to **FBUSY L**. Thus, on the leading edge of **FBUSY L**, the state of **FBUSY H** is clocked into the Read flip-flop, causing it to go to the set state. This sequence is shown in Figures 4-17 and 4-18.

The read-restore (**DIN**) cycle continues as shown in Figure 4-17. **PREAD H** activates the read time generator, producing time signals prefixed with "RT." Each signal is a 225 positive-going pulse whose leading edge is delayed with respect to **PREAD H**. Hence, the leading edge of **RT225 H**, shown in Figure 4-16, occurs 225 ns after the leading edge of **PREAD H**, and approximately 275 ns after **BSYNC L** is asserted. Note that **RT225 H** is inverted and applied to the clear input of the Read flip-flop, establishing the 225 ns pulse width for RT pulses. **RT225 H** goes low, 225 ns later. This time occurs 400 ns (total) after **BSYNC L** is asserted and it is referenced on Figure 4-16 as (**TS00 L**).

The pulse produced by the RC network on the leading edge of **FBUSY L** is inverted to produce the **CLR0 L** and **CLR1 L** signals, which clear the memory data register for the new read data. **READ EARLY** occurs on the leading edge of **PREAD H** and remains active for the duration of **RT50 H**, producing a 300 ns pulse. **RT25 H** goes high 25 ns later, producing the **READ LATE L** signal; this signal remains true for the duration of **RT100**, resulting in a 325 ns pulse. Read data is valid at the sense amplifier inputs from 200 to 275 ns after **READ EARLY L** goes active. **RT175 H** is gated with **RT50 H** to produce the sense amplifier strobes **STROBE0** and **1 H**. The trailing edge of **RT50 H** occurs 100 ns after the leading edge of **RT175 H**, negating the strobes. During strobe time, the sense amplifier data bits set the appropriate flip-flops that comprise the memory data register, and store the memory read data.

The bus master device initiates the data transfer portion of the **DATI** transaction by asserting **BDIN L**. The Replay Enable flip-flop is set on the trailing edge of **RT100 H** 375 ns after **BSYNC L**. If **RDIN H** (**BDIN L** inverted) is received earlier than 375 ns after **BSYNC L**, the Reply flip-flop input gates wait 375 ns to produce an active **RPLY SET L** signal (Figure 4-17), which direct-sets the Reply flip-flop and produces the active **FRPLY H** and **BRPLY L** signals. **FRPLY L** is gated with **RDIN L**, and inverted, producing the **DATA OUT L** signal which gates memory data register bits onto the **BDAT** bus. If **RDIN H** is received later than 375 ns after **BSYNC L**, the Reply flip-flop sets on the leading edge of **RDIN H**. The trailing edge of **RT150 H** (**T425 L**) is gated with **RPLY SET L**, producing a write

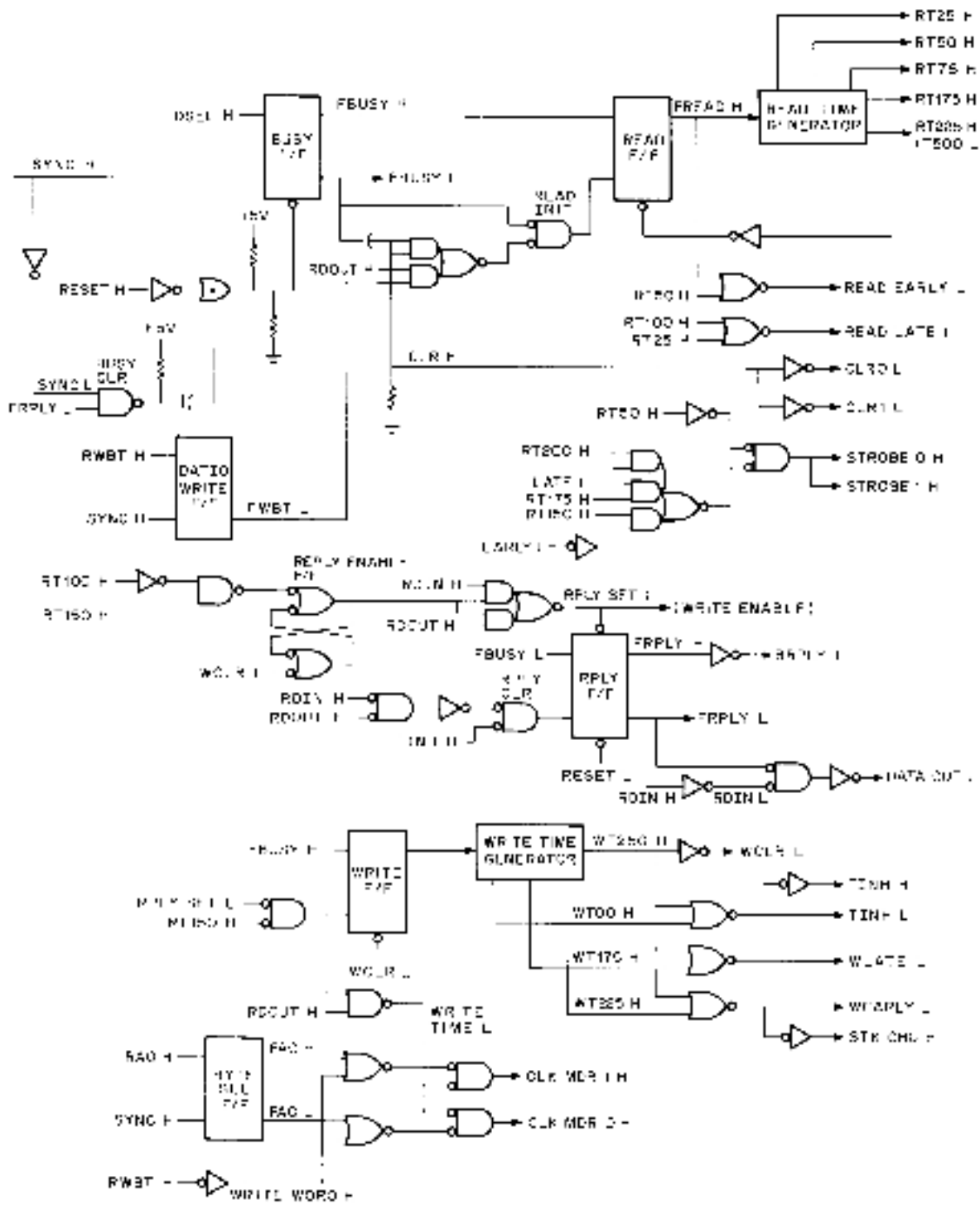

Figure 4-16 MMV11-A Timing and Control Circuitry

initiate pulse which clocks the high FBUSY H signal into the Write flip-flop, initiating the restore portion of the memory cycle.

Restore timing is produced by the write time generator in a manner similar to that described for read time generation. At WT00 H time, TINH H and TINH L (475 ns pulses) are produced for the inhibit drivers. TINH H also inhibits the Reply Clear gate, and the Reply flip-flop remains set for the remainder of the memory cycle. WEARLY L and STK CHG H go active on the leading edge of WT175 H and remain active for 350 ns. Similarly, WLATE L goes active on the leading edge of WT175 H and remains active for 325 ns. At WT250 H time, WCLR L is produced, clearing the Reply Enable and Write flip-flops; thus, write time generator outputs are 250 ns pulses. Memory data is restored (written) during the time that TINH H, WEARLY L, and WLATE L are active. The memory cycle terminates when both SYNC L and RPLY L go to their passive states. The Busy Clear gate detects this condition, producing a low pulse which clears the Busy flip-flop, and the memory cycle ends.

The DATO cycle is similar to the DATI cycle except that during the addressing portion of the bus cycle, the bus master device asserts BWTBT L. RWBT H goes high, and the leading edge of SYNC H clocks the byte flip-flop to the set state. The active FWBT L signal is only used when in the write portion of the DATIO cycle, as described later. However, during a DATO bus transaction, RDINH is not received; instead, RDOUT H is received, enabling the REPLY SET L gates, as shown in Figure 4-18. RDOUT enables one input to the WRITE TIME L gate. At the same time that the Write flip-flop clocks to the set state, WRITE TIME L goes low, enabling CLK MDR0 and 1 H gates. Since a DATO bus cycle is in progress, BWTBT L remains passive during the data transfer portion of the bus cycle. Hence, RWBT H is low, WRITE WORD H is

high, and the two byte select OR gates apply low signals to the remaining CLK MDR gates. CLK MDR 0 and 1 H then clock the BDAL bus data into the memory data register; the previously read data is lost. The write portion of the cycle continues as described for the restore portion of the DATI operation.

When executing a DATOB bus transaction, BWTBT L, and RWBT H remain active for the duration of the bus cycle. Hence, the WRITE WORD H signal remains passive. The Byte Select flip-flop that stores byte address bit RA0 H during addressing time enables generation of only one CLK MDR H signal. When RA0 H is low, FA0 L goes high and CLK MDR 0 H clocks low byte data bits from only BDAL0—7 L into the memory data register. Register bits 8—15 remain unchanged. Similarly, when RA0 H is high, FA0 H goes high and CLK MDR 1 H clocks high byte data bits from only BDAL8—15 L into the memory data register. Register data bits 0—7 remain unchanged. The write portion of the memory cycle then continues as previously described.

When executing a DATIO bus cycle, two complete memory cycles are executed. They include a DATI and a DATO or DATOB cycle as previously described. However, when executing a DATIO bus transaction, BSYNC L remains active for the duration of the transaction. Hence, SYNC H, which generates FBUSY L during the read-restore portion of the cycle, cannot initiate the second read-modify-write memory cycle. Instead, FWBT L, stored during the addressing portion of the cycle, enables a read initiate pulse on the leading edge of RDOUT H. The Read flip-flop goes to the set state and operation continues as described for DATO or DATOB bus transactions.

4.3.2.5 DC Protection and Vcc Switch — DC protection and Vcc switch circuits are shown in Figure 4-19. The dc protection circuit is activated during power-fail

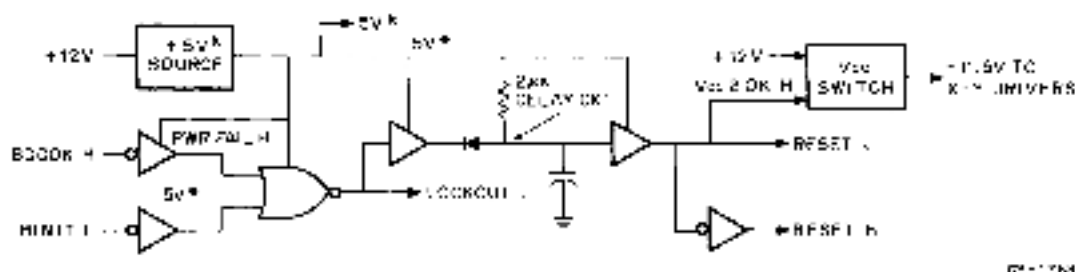

Figure 4-19 DC Protection and Vcc Switch Circuits

or bus initialize conditions. **BDCOK H** and **BINIT L** are inverted and ORed to produce **LOCKOUT L**. Normally, this signal is passive (high), enabling bank addressing and resulting in an active **DSEL H** signal when the memory is addressed. However, if **BDCOK H** goes low (power fail) or **BINIT L** is asserted low, **LOCKOUT L** immediately inhibits the bank addressing function.

The reset signals are also generated by this circuit. **RESET L** goes active (low) whenever **LOCKOUT L** is active. A 2 μ s delay circuit enables the memory to complete its present cycle before **RESET**. **RESET L** is also inverted to produce **RESET H**; both signals are used to clear (initialize) memory timing control circuits.

To produce a 5V* source for reset circuits and bus receivers **BSYNC L**, **BDIN L**, **BDOUT L**, **BWIBT L**, and **BREF L**, +12 V power is regulated. Thus, if +12

V is removed, all MMV11 memory operations are disabled. However, if +5 V is removed and the +12 V remains, the 5 V* allows memory protect logic to remain functional.

RESET L is also applied to the **VCC20K H** input to the Vcc switch circuit. This signal is high only when both +5 V and -12 V power sources are normal. The Vcc switch comprises a transistor (Vcc switch), which is turned on when power is normal to produce +11.5 V power for X-Y driver circuits.

4.3.2.6 DC-DC Inverter The de-dc inverter circuit is shown in Figure 4-20. It is comprised of an inverter oscillator using a saturable transformer, a negative rectifier, and a filter. A 3-terminal regulator chip produces the regulated -5 V for sense amplifier operation.

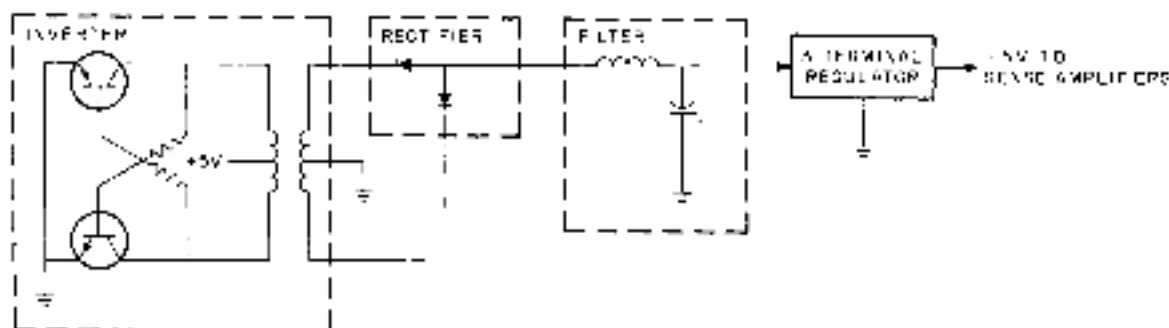

Figure 4-20 DC-DC Inverter Circuit

4.4 MRV11-A 4K BY 16-BIT READ-ONLY MEMORY

4.4.1 General

The MRV11-A is a basic read-only memory module on which the user can install programmable read-only memory (PROM) or masked read-only memory (ROM) chips. All PROM/ROM chip sockets and addressing and control circuits are contained on a single 8.5 by 5 inch module.

The MRV11-A features:

- 4096 by 16-bit capacity using 512 by 4-bit chips or 2048 by 16-bit capacity using 256 by 4-bit chips.
- Compatibility with chips available from multiple sources.

- Jumpers that allow the user to select the 4K memory address space which the MRV11-A will respond, chip type, and upper or lower 2K segment (when 256 by 4-bit chips are used).

4.4.2 Functional Description

4.4.2.1 General—Major functions contained on the MRV11-A module are shown in Figure 4-21. ROM data stored on the module can be addressed and read by the LSI-11 processor or other DMA devices by executing a DATA bus cycle. Data/address lines **BDAL0-15 L** and three bus interface control signals (**BSYNC L**, **BHIN L**, and **BRPLY L**) comprise all interface signals required for accessing the read-only memory. **BREF L** inhibits **BRPLY L** and **BDAL** bus drivers during memory refresh operations.

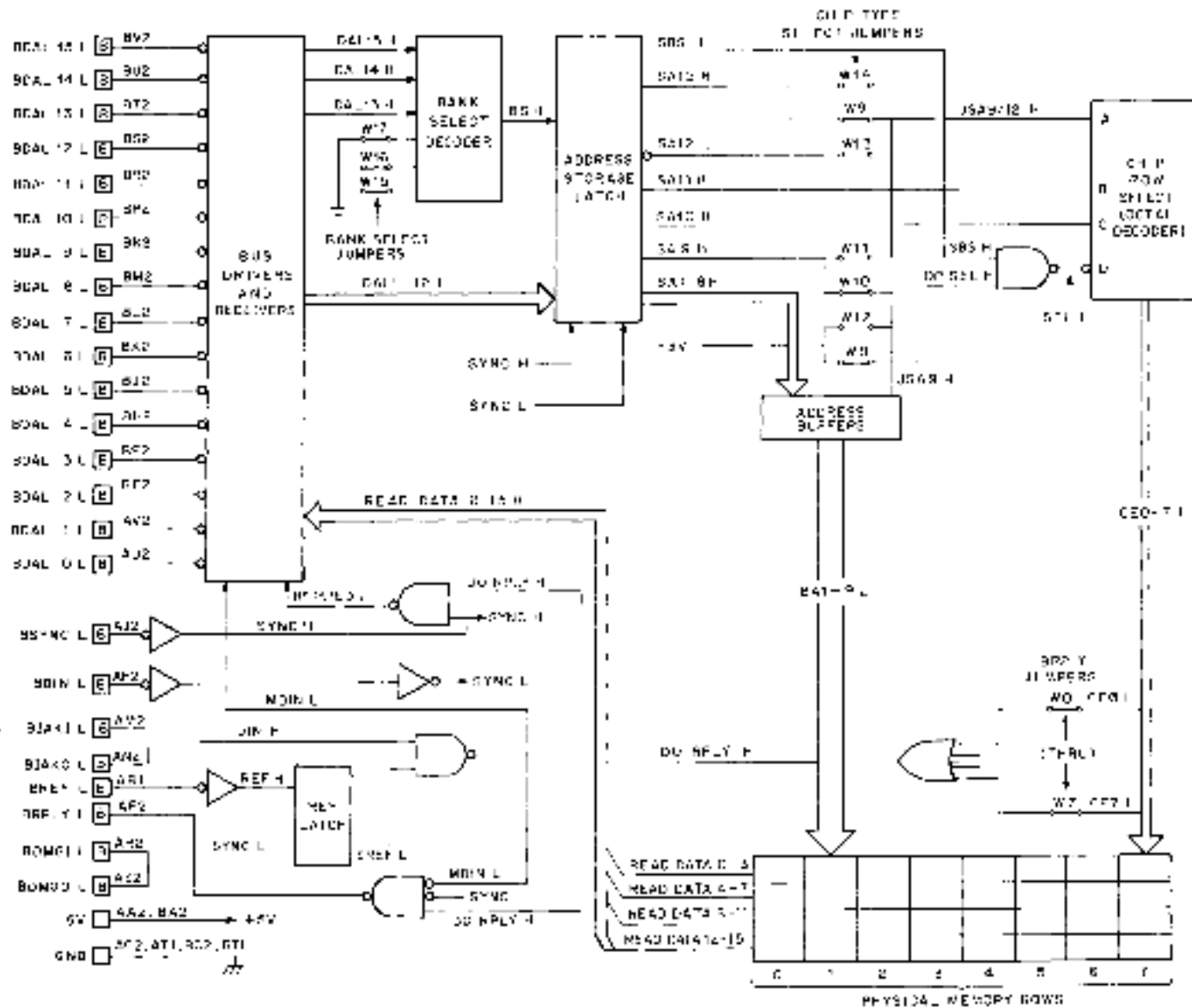

Figure 4-21 MRV11 A Logic Block Diagram

4.4.2.2 Addressing — A master device can address any 16-bit word in the 4K module by placing appropriate address bits on **BDAL1-15 L** during the addressing portion of the **DAT1** cycle. **BDAL0** is not used on the **MRV11-A** since this address bit functions only as a byte pointer during **DAT0B** and the write portion of **DAT10B** bus cycles. Bus receivers route **DAL13-15 H** to the bank select decoder and **DAL1-12 H** to the address storage latch. Bank selection occurs when the 4K address encoded on **DAL13-15 H** is equal to the user-configured value selected by jumpers **W17-W15**. The resulting bank select (**BS H**) and address bits **DAL13-15 H** are then stored in the address storage latch on the leading edge of **BSYNC L**. Stored address bits **SA1-8 H** are buffered to produce **BA1-9 L** which are applied to all ROM/PROM chips on the module.

When 512 by 4-bit chips are used, **SA9 H** is routed via jumper **W10** to a buffer, producing the inverted **BA9 L** address bit for all chips (pin 14). However, when 256 by 4-bit chips are used, **W10** is removed and **W12** is connected, forcing a low (chip enable) signal to become applied to all chips (pin 14); note that 256 by 4-bit chips do not receive address bit 9.

Memory chips sockets are arranged in eight physical rows of four sockets each. The memory is expanded by installing all four chips in each desired row. Four chips provide the full 16-bit word storage for **LSI-11** instructions and data. Only one row is enabled by a chip enable (**CE**) signal, produced by chip row select logic and chip type jumpers.

When 512 by 4-bit chips are used, jumpers **W8**, **W9**, and **W10** are installed. The chip row select octal decoder receives stored address bits **SA10**, **SA11**, and **SA12** on its A, B, and C inputs, respectively, as shown

in Figure 4-22. Bank Select Stored (**SBS H**) is gated to produce a low **SEL L** enable signal, which is applied to the **D** input of the decoder. (The decoder is actually a decimal decoder; whenever a high signal is applied to its **D** input, outputs 0-7 are inhibited.) One decoder output goes low, enabling the appropriate physical row addressed by bits **SA10-12 L**.

When 256 by 4-bit chips are used, jumpers **W8**, **W9**, and **W10** are removed and jumpers **W11**, **W12**, and either **W13** or **W14** are installed, as shown in Figure 4-23. **SA10** and **SA11** are applied to octal decoder A and B inputs, respectively. Bit **SA9**, which is not used to directly address the 256 by 4-bit chips is then applied to input C of the octal decoder. **SA12 H** and **SA12 L** are available for jumper selection of the desired 2K segment within the 4K bank. **W13**, when installed, selects the lower 2K; **W14** selects the upper 2K. When the selected segment is addressed, **OP SEL** goes high. This signal is gated with **SBS H** to produce the low (active) octal decoder enable signal.

4.4.2.3 Data Read Operation — Once the ROM/PROM chip sockets are addressed, the data can be read by the bus master device. Data is available within 120 ns after **BSYNC L** is received. One active **CE0-7 L** signal produces the active **DO RPLY H** signal, which enables reply and **BDAL** bus driver gating. Active **DO RPLY H** and **SYNC H** signals are gated, producing the **REPLIED L** signal, which enables one of the two bus driver enable inputs. The remaining enable input is **MDIN L**. The bus master device asserts **BDIN L** to request the data. **DIN H** is ANDed with the passive (high) **SREF L** signal, producing **MDIN L**, and read data is enabled onto **BDAL0-15 L**. Active **MDIN L**, **SYNC L**, and **DO RPLY H** signals also enable the **BRPLY L** bus driver, producing the required response to **BDIN L**.

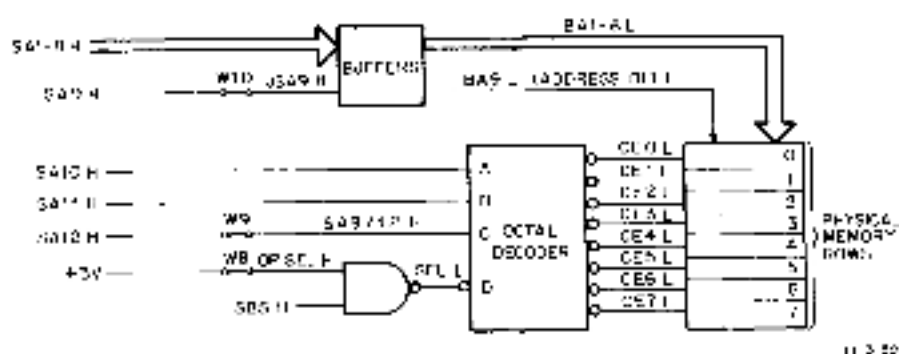

Figure 4-22 512 by 4-Bit Chip-Jumper Configuration

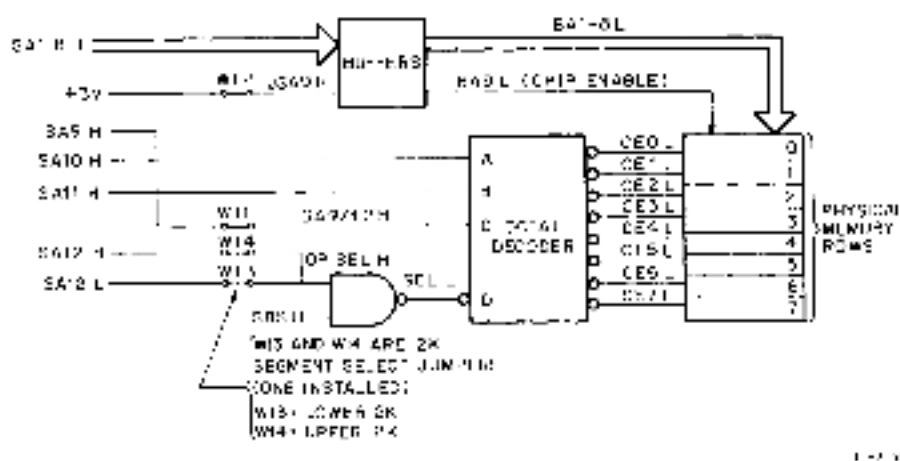

Figure 4-23 256 by 4-Bit Chip-Jumper Configuration

When the system is in a memory refresh operation, the MRV11-A must not respond to the BSYNC/BDIN refresh bus transactions. BRPL L is asserted during the addressing portion of the bus cycle and the refresh latch stores REF H on the leading edge of SYNC L. SREF L goes low and inhibits the MDIN L signal. Hence, BDAL and BRPLY L bus drivers are not enabled.

4.5 MSV11-B 4K BY 16-BIT SEMICONDUCTOR READ/WRITE MEMORY

4.5.1 General

The MSV11-B is a 4K by 16-bit dynamic MOS read/write memory module which can be used for temporary storage of user programs and data. The storage capacity is 4096, 16-bit words. Memory address selection is user-configured by installing or removing jumpers contained on the module. Memory refresh is directly controlled by LSI-11 bus signals. Refresh operations can be automatically controlled by the LSI-11 microcomputer module once every 1.6 ms (approximately) or performed by another device. The MSV11-B is LSI-11 bus-compatible and capable of either programmed I/O data transfers with the processor or DMA transfers with other LSI-11 bus devices.

The MSV11-B features:

- 4096 by 16-bit word.
- Fast access time — 550 ns maximum.
- Low power — 12.7 W for the module, worst case.
- Dynamic MOS memory chips — Refresh is automatically controlled by processor or by a DMA device.

- User-configured 4K addresses — Three jumpers allow user address configuration.

4.5.2 Functional Description

Major functions contained on the MSV11-B module are shown in Figure 4-24. Memory data can be stored (written) or read by the LSI-11 microcomputer, or other bus master devices operating in the DMA mode, with appropriate bus cycles: DATA (16-bit word write operation); DATOB (8-bit byte write operation); DATA (16-bit read operation); or DATIOB [16-bit read-modify-write (8 or 16-bit) operation].

Addressing is initiated by a master device (either the LSI-11 processor or a DMA device) by placing the 16-bit address on BDAL0-15 L and asserting BSYNC L, latching the address (and bank select information) in the address register. Address hits are routed from the BDAL bus receivers onto the module's DAL0-15 H bus to the 13-bit address and bank select register input. Address bits BDAL.13-15 L are decoded by the bank address decoder. Decoder output signal BS H will go active (high) only when the jumper-selected bank address is decoded. The active BS H signal is stored along with the 13-bit memory address for the duration of the operation.

The memory array comprises sixteen 16-pin 4K by 1-bit memory chips which require the address multiplexer to address the array with two 6-bit bytes. Address multiplexer control logic responds to the active SYNC H and stored active bank select (LBS L) signal by immediately generating an active Row Address Strobe (RAS). This signal remains active for the duration of the active SYNC H signal. Address

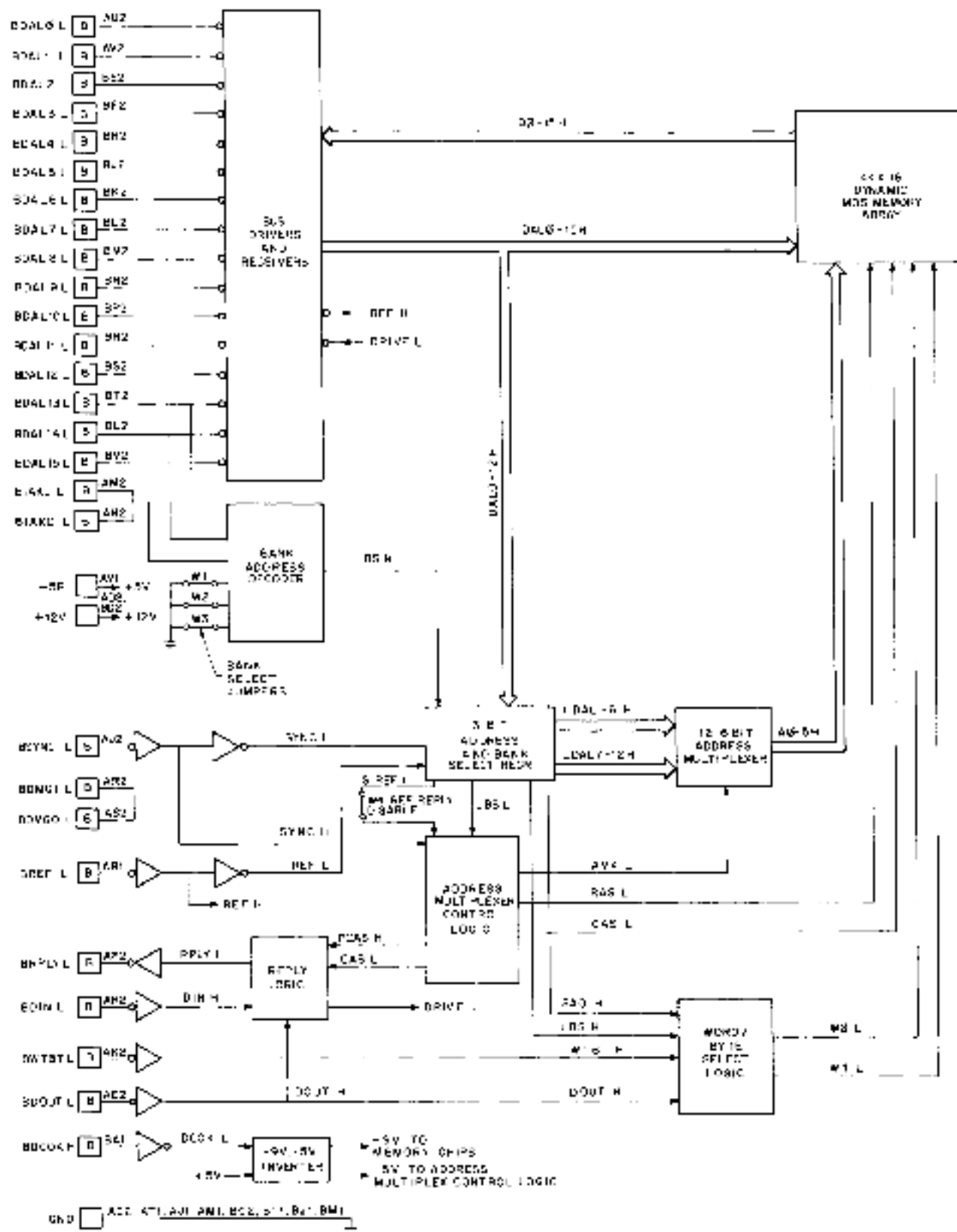

Figure 4-24 MSV11-B Logic Block Diagram

multiplex control AMX L is initially passive (high), multiplexing the stored row address bits (LDAL7-12 H) through the 12:6-bit address multiplexer and into all memory chips. After approximately 150 ns, address multiplex control logic generates an active column address strobe (CAS) and an active AMX L signal. Multiplexer column address bits (LDAL1-6 H) are then strobed into all memory chips. This completes the chip addressing portion of the memory operation.

When in a memory read operation, the bus master device asserts B/MN L. The data from the accessed memory location is present on the D0-15 H bus and at bus driver inputs. Reply logic responds to BDN L by generating an active DRIVE L signal which gates the memory read data onto BDAL0-15 L for input to the requesting device; reply logic also asserts BRPLY L to complete the data transfer portion of the cycle.

When in a memory write operation (at the write portion of a DATOB cycle) the addressing portion of the operation is similar to the read cycle addressing. After the addressing portion of the cycle has been completed, the master device asserts BDOUT L, and BWTBT L either goes passive (high) if a DATO (word) write cycle is to be performed, or remains asserted if a DATOB (byte) write cycle is to be performed. Word/byte select logic responds to the DATO cycle by asserting both W0 L and W1 L for the duration of the cycle, enabling DATA-15 H bits to be written into the addressed location in all memory chips. However, in a DATOB cycle with A0 H low (even byte), only W0 L goes active, enabling the writing of DATA-7 H into the addressed location in the appropriate eight memory chips. Similarly, if A0 H is high (odd byte), only W1 L goes active, enabling only DATA-15 H bits to be written into the addressed location in the appropriate eight memory chips. The reply logic also responds to the active BDOUT L signal by asserting BRPLY L, indicating that the data has been written, completing the data transfer.

The memory chips in the MSV11-H require a refresh operation once every 1.6 ms. This operation is entirely under the control of either processor microcode or a DMA device, as selected by the user. The address multiplex control logic responds to BREF L, generated by the refresh-controlling device, by simulating a "bank selected" operation. (All system memory banks are simultaneously selected during refresh.) Refresh is then accomplished by a device by executing 64 successive BSYNC L/BDN L operations while incrementing BDAL1-6 by one on each bus transaction. Refresh is

simply a series of forced memory read operations where only the row addresses are significant. Each of the 64 rows in all dynamic MOS memory chips in an LSI-11 system are simultaneously refreshed in this manner. The REF H signal inhibits all BDAL bus drivers for the duration of the refresh operation.

A de-to-de inverter circuit is included on the module for negative voltage generation. Output voltages include -9 V for the MOS memory chips and -5 V for linear devices in the address multiplex control logic. Hence, only -12 V and -5 V power inputs are required for module operation. The BDCOK H signal starts de-to-de inverter oscillation when bus power is applied.

4.6 (Paragraph 4.6 and Figure 4-25 are deleted.)

4.7 DLV11 SERIAL LINE UNIT

4.7.1 General

The DLV11 is the basic interface module used for connecting asynchronous serial line devices to the LSI-11 bus. All circuits are contained on a single 8.5 by 5 inch module.

The DLV11 features:

- Either an optically isolated 20 mA current loop or an EIA interface selected by using the appropriate interface cable option.
- Selectable crystal-controlled baud rates: 50, 75, 110, 134.5, 150, 200, 300, 600, 1200, 1800, 2400, 4800, 9600, and an externally supplied rate.
- Jumper-selectable stop bit and data bit formats.
- LSI-11 bus interface and control logic for interrupt processing and vector generation.
- Interrupt priority determined by electrical position along the LSI-11 bus.
- Control/status register (CSR) and data registers compatible with PDP-11 software routines. CSRs and data buffer registers directly accessed via processor instructions.
- Plug, signal, and program compatible with PDP-11 DL11A, B, C series.

this page intentionally left blank.

This page intentionally left blank.

4.7.2 Functional Description

4.7.2.1 General— Major functions contained on the DLV11 module are shown on Figure 4-26. Communications between the LSI-11 microcomputer and the DLV11 are executed via programmed I/O operations or interrupt-driven routines, as described in Chapter 3.

4.7.2.2 UAR/T Operation— The main function on the DLV11 module is the Universal Asynchronous Receiver/Transmitter (UAR/T) chip. This is a 40-pin LSI chip that is capable of parallel I/O with the computer bus and asynchronous serial I/O with an external device. Jumpers which allow the user to select parity functions, number of stop bits, and number of data bits are described in Paragraph 6.2.2. Both transmit and receive functions are totally asynchronous in operation. The transmit clock is always driven by the baud rate generator's CLK L signal. CLK L is applied to one MSPAREB backplane pin (BK1), where it is connected to MSPAREB pin BL1; this is the receive function UAR/T clock input (RCLK L) signal.

When a user application requires split transmit and receive hand rates, the MSPARE jumper can be broken from pins BK1 and BL1 and an external receive baud rate signal can be applied to BL1 (the drive frequency should be 16 times the desired hand rate).

4.7.2.3 Baud Rate Generator— The baud rate generator produces the desired UAR/T clock and a fixed 2.4576 MHz clock for the -12 V inverter circuit. A crystal-controlled oscillator produces the basic 2.4576 MHz frequency for the baud rate generator. A single baud rate generator chip divides this frequency to produce the available baud rates. Jumpers, which are described in Paragraph 6.2.2, select the desired baud rate for the CLK L output signal.

4.7.2.4 Bus Drivers and Receivers— Bus drivers and receivers interface directly with the LSI-11 bus. Line receivers produce RDAB0-12 H signals in response to BDAL0-12 L bus signals. When an input data or vector transfer is desired, function decoding and control logic generates an active INPUT ENABLE signal, which enables the bus drivers. When a data input operation is selected, the UAR/T receiver data buffer contents (RD0 ? H) are routed through the data selector (DDAB0 ?H) to the BDAL bus. When responding to an interrupt acknowledge signal, interface control logic generates VECT_L, which selects the vector address produced by jumpers W6-W10 (Paragraph 6.2.2). In addition, DAL0, 6, 7, and 15 are driven by CSR selection and gating circuits when a data input transfer

from either the receiver (RCSR) or transmitter (XCSR) control/status registers is performed.

4.7.2.5 Address Decoding— Address decoding logic responds to the address present on the bus when BSYNC L is asserted. The DLV11 device address is contained on RDAB3-12 H, along with address bits RDAB0, 1, and 2 H, which are decoded by function decoding logic. Address bits are not required for bank selection since all devices, such as any DLV11, reside in the upper 4K bank (addresses ranging from 28-32K). The processor generates an active BBS7_L signal, indicating an I/O device addressing operation. Address selection jumpers A3-A12 allow the user to configure address bits 3-12, as described in Paragraph 6.2.2. When the DLV11 is addressed, device selection is indicated by an active MF signal. This signal remains active throughout the entire I/O cycle (while BSYNC L remains active), enabling function decoding.

4.7.2.6 Function Decoding and Control— Function decoding and control logic decodes DLV11 internal gating functions based upon address selection, address bits RDAB0, 1, and 2 H, bus signals BDIN L, BDOUT L, and BSYNC L, and the VECT L signal generated by the interface control logic. In addition to generating function select signals, this circuit inverts BSYNC L to produce SYNC H whose leading edge clocks the address decoding logic. A truth table of function select signals is provided in Table 4-2.

4.7.2.7 Interface Control Logic— Interface control logic produces the BRPLY L signal in response to I/O operations, contains the interrupt control logic, and receives and distributes the BINIT L initialize signal. This function also contains the Transmit Data Interrupt Enable (TDINTEN H) flip-flop and Receiver Data Interrupt Enable (RDINTEN H) flip-flop; both flip-flops can be read or written by the LSI-11 microcomputer. RDINTEN is set or reset by BDAL6 L; the flip-flop is clocked on the leading edge of SEL0OUT L. Similarly, TDINTEN is set or reset by BDAL6 L; this flip-flop is clocked on the leading edge of SEL4OUT L.

Receiver-generated interrupts occur as a result of the RDINTEN flip-flop being set (interrupts enabled) and an active receiver Data Available (DA H) UAR/T status signal. When this condition occurs, the Receiver Data Interrupt Request flip-flop sets and generated an active BRQ L signal. The LSI-11 microcomputer responds (if its PS bit 7 is not set) by asserting BDIN L; this enables the device requesting the interrupt to place its vector on the BDAL bus when the interrupt request

Table 4-2
DLV11 Function Decoding

Address Inputs		Control Inputs				Function Select Signals (low-active)					
A1	A2	RDRST	RDRSTL	MRST	SELEDRST	SEL2RSTL	SEL4RSTL	SEL8RSTL	SEL16RSTL	SEL32RSTL	
X	X	X	X	H	F	0	0	0	0	0	
L	L	L	X	L	L	H	H	H	H	H	
H	L	L	X	L	F	L	0	0	0	0	
L	H	L	X	L	F	0	L	H	H	H	
L	L	H	L	L	H	0	0	0	0	0	
L	L	H	L	L	H	0	0	0	H	L	
H	H	H	L	L	H	H	H	H	H	L	
H	H	L	H	L	H	0	0	0	L	0	

is acknowledged. The processor then asserts **BIAKO L**, acknowledging the interrupt request. The interface control logic receives **BIAKI L** and responds by generating active **VLC L** and **BRPLY L** signals, placing its interrupt vector on the LSI-11 bus and clearing the **BIKQ L** signal. Once the service routine for the DLV11's receive function has been entered, the receiver data buffer (RBUF) can be read. The stored **BIAK** signal is cleared when the next **BIAKI L** signal is received and the DLV11 is not requesting an interrupt.

Transmitter-generated interrupts occur in a manner similar to the receiver-generated interrupts. However, they occur as a result of the **TDINTEN** flip-flop being set (interrupts enabled) and when the Transmitter Buffer Empty (**TBMT H**) UAR/T signal is active (high). Once the service routine has been entered for the DLV11's transmit function, the transmitter data buffer (XBUF) can be loaded and a new character transmission initiated. Note that if the transmitter and receiver functions request interrupts simultaneously, the receiver function has priority over the transmitter. If **BIAKI L** is received and the DLV11 is not requesting an interrupt, it passes **BIAKO L** for a lower priority interrupt request.

The interface control logic also generates the DLV11's **BRPLY L** signal. It generates this signal when any function select signal is asserted or **VLC L** is generated.

The system initialize signal (**BINIT L**) is generated by the processor to reset all peripheral device registers. Interface control logic responds by clearing all control flip-flops, including the Interrupt Request, Interrupt Acknowledge, and Break flip-flops. The UAR/T's RBUF and XBUF data registers are not cleared by **BINIT L**; however, the initialize signal does clear the **DA H** signal and set the **TBMT H** signal.

4.7.2.8 CSR Selection and Gating — CSR selection and gating logic enables the LSI-11 microcomputer to read receiver and transmitter control/status bits. Functions are summarized below.

Read RCSR (SEI0RSTL asserted)

CARRIER or CLR TO SEND or DATA SET READY → **BDAL15**

DAH → **BDAL7**

ROINTENH → **BOAL6**

Read XCSR (SEL4RSTL asserted)

TBMT H → **BDAL7**

TDINTENH → **BDAL6**

BREAK H → **BDAL0**

4.7.2.9 Break Logic — Break logic comprises the Break status flip-flop. It is set or cleared by the LSI-11 microcomputer by **BDAL0 L** while executing a bus output cycle with the XCSR. Thus, the duration of the break signal is program controlled. The Break flip-flop is clocked on the leading edge of the **SEI4OUT H** signal. When set, the serial output line is continuously asserted (space). The status of the Break flip-flop can be read in XCSR bit 0.

4.7.2.10 Reader Run Logic — The reader run logic enables DLV11 generation of a **READER RUN** pulse for 20 mA current loop teletypewriter devices. It is enabled by loading RCSR bit 0; the LSI-11 microcomputer asserts **BDAL0 L** and causes generation of the **SEI4OUT H** signal (load RCSR). **READER RUN** is asserted and remains active for the duration of one-half of a start bit. The start bit of the serial input (SI) from the low-speed reader initiates a 4-bit binary counter. When eight **CLK L** pulses have been counted (equivalent to one-half of the start bit), **READER RUN** is negated. After the complete character has been read by the LSI-11 microcomputer, the next character can be read in the same manner.

4.7.2.11 EIA Interface Circuits — An EIA interface is provided by EIA drivers and receivers. EIA signal drivers are provided for EIA **TRANS DATA**, **REQUEST TO SEND**, **DATA TERMINAL READY** (always an active high/space state), and **BUSY** (always an active

low/mark state). Jumper J1A applies -12 V to the EIA driver chip when the DRV11 is used with EIA-compatible devices. EIA signal receivers are provided for EIA DATA IN, CARRIER or CLEAR TO SEND, and DATA SET READY. The optional BC05C modem cable connects the output signal of the EIA DATA IN driver (EIA/TTL RCVD DATA) to the TTL SERIAL DATA IN input to the UAR/T.

4.7.2.12 20 mA Loop Current Interface — The 20 mA loop current interface is provided by optical isolation. An active 20 mA current loop is provided when jumpers CL1 through CL4 are installed. If the jumpers are removed, 20 mA passive current loop operation is selected. The optional BC05M cable assembly connects the 20 mA/TTL RCVD DATA optical coupler signal output to the TTL SERIAL DATA IN input of the UAR/T. When the DRV11 is used with a 110 baud teletypewriter device, a 0.005 μ F, 100 V filter capacitor should be installed between terminals TP1 and TP2.

4.7.2.13 -12 V Inverter — The -12 V inverter circuit generates -12 V for use by the UAR/T chip and EIA driver and receiver chips. Input to the circuit is the CLK signal (2.4576 MHz) and +12 V. The output is center regulated to -12 V.

4.8 DRV11 PARALLEL LINE UNIT

4.8.1 General

The DRV11 is a general-purpose interface unit used for connecting parallel line devices to the LSI-11 bus. All circuits are contained on a single 8.5 by 5 inch module.

The DRV11 features:

- 16 diode-clamped data input lines.
- 16 latched output lines.
- 16-bit word or 8-bit byte programmed data transfers.
- User-assigned device address decoding.
- LSI-11 bus interface and control logic for interrupt processing and vector generation.
- Interrupt priority determined by electrical position along the LSI-11 bus.
- Control/status registers (CSR) and data registers that are compatible with PDP-11 software routines. Plug, signal, and program compatible with DR11-C.

- Four control lines to the peripheral device for NEW DATA READY, DATA TRANSMITTED, RQSTA, and RQSTB.
- Logic compatible with TTL or DTL devices.
- Program-controlled data transfer rate of 90K words per second (maximum).
- Maximum drive capability of 25 ft of cable.

4.8.2 Functional Description

4.8.2.1 General — Major functions contained on the DRV11 module are shown in Figure 4-27. Communications between the LSI-11 microcomputer and the DRV11 are executed via programmed I/O operations or interrupt-driven routines, as described in Chapter 3.

The DRV11 is capable of storing one 16-bit output word or two 8-bit output bytes in DROUTBUF. The stored data (OUTPUT ID) is routed to the user's device via an optional I/O cable connected to J1. Any programmed operation that loads either a byte or a word in DROUTBUF causes a NEW DATA READY H signal to be generated, informing the user's device of the operation.

Input data (DRINBUF) is gated onto the BDAL bus during a DATA bus cycle. All 16 bits are placed on the bus simultaneously; however, when the processor is involved in 8-bit byte operation, it uses only the high or low byte. When the data is taken by the processor, a DATA TRANS H pulse is sent to the user's device to inform the device of the data transfer.

4.8.2.2 Addressing — When addressing a peripheral device interface such as the DRV11, the processor places an address on BDAL0-15 L, which is received and distributed as BRD0-15 H in the DRV11. The address is in the upper 4K (28-32K) address space. On the leading edge of BSYNC L, the address decoder decodes the address selected by jumpers A3-A12 and sets the Device Selected flip-flop (not shown); the active flip-flop output is the ME signal, which enables function selection and I/O control logic operation. At the same time, function selection logic stores address bits BRD0-2.

4.8.2.3 Function Selection — Function selection and I/O control logic monitors the ME signal and bus signals BDIN L, BDOUT L, and BWTBT L. It responds by generating appropriate Select signals which control internal data gating, NEW DATA READY H or DATA TRANS H output signals for the user's

Table 4-3
DRV11 Device Function Decoding

Programmed Operation	Stored Device Addr. Bits (s-2)	RWTBL During Data Transfer	BDIN L	BDOUT L	Bus Cycle Type	Select Signals
Write DRCSR	0	0	H	L	DATO	SEL2OUT L
Read DRCSR	0	1	H	L	DATOR	
Write DROUTBUF	0	0	L	H	DATI or DATIP	SEL2IN L
Word	2	0	H	L	DATO	SEL2OUT (W-HB) L, SEL2OUT (W-LB) L, and NEW DATA READY H
Low Byte	2	1	H	L	DATOR	SEL2OUT (W+LB) L and NEW DATA READY H
High Byte	3	1	H	L	DATOR	SEL2OUT (W+HB) L and NEW DATA READY H
Read DROUTBUF	2	0	L	H	DATI or DATIP	SEL2IN L
Read DRINBUF	4	0	L	H	DATI	SEL-HIN L and DATA TRANS H

NOTE

When addressed, the DRV11 always responds to either BDIN L or BDOUT L by asserting BRPLY L (L = assertion).

device, and the BRPLY L bus signal which informs the processor that the DRV11 has responded to the programmed I/O operation. Since the DRV11 appears to the processor as three addressable registers (DRCSR, DROUTBUF, and DRINBUF) that can be involved in either word or byte transfers, the three low-order address bits stored during the addressing portion of the bus cycle are used for function selection. The select signals relative to I/O bus control signals and address bits 0-2 are listed in Table 4-3.

NEW DATA READY H is active for the duration of BDOUT L when in a DROUTBUF write operation. This signal is normally active for 300 ns. However, by adding an optional capacitor in the BRPLY L portion of the circuit, the leading edge of BRPLY L is delayed, effectively increasing the duration of the NEW DATA READY H pulse to 1200 ns (maximum); adding the capacitor also increases the DATA TRANS H pulse width in exactly the same manner.

DATA TRANS H is active for the duration of BDIN L when in a DRINBUF read operation. This signal is normally active for 300 ns. The time, however, can be extended by adding the optional capacitor to the BRPLY L portion of the circuit as previously described.

4.8.2.4 Read Data Multiplexer — The read data multiplexer selects the proper data and places it on the BDAL bus when the processor inputs DRCSR, DROUTBUF or interrupt vectors; DRINBUF contents are gated onto the bus separately. The select signals (previously described) and VECTOR H, produced by the interrupt logic, control read data selection.

4.8.2.5 DRCSR Functions — The control/status register (DRCSR) is comprised of separate functions. Four of the six significant DRCSR bits can be involved in either write or read operations. The remaining two bits, 7 and 15, are read-only bits that are controlled by the external device via the REQ A H and REQ B H signals, respectively. The four read/write bits are stored in the 4-bit CSR latch. They represent CSR0 and CSR1 (DRCSR bits 0 and 1, respectively), which can be used to simulate interrupt requests when used with an optional maintenance cable. INT ENB A and INT ENB H (bits 6 and 5, respectively) enable interrupt logic operation. Note that CSR0 and CSR1 are available to the user's device for any user application.

4.8.2.6 DRINBUF Input Data Transfer — DRINBUF is an addressable 16-bit read-only register that receives data from the user's device for transmission to

the LSI-11 bus. Data to be read is provided by the user's device on the IN0-15 H signal lines. Since the input buffer consists of gating logic rather than a flip-flop register, the user's device must hold the data on the lines until the data input transaction has been completed.

The input data is read during a DATA sequence while bus drivers are enabled by the SEL4IN L signal. The DATA TRANSMITTED pulse that is sent to the user's device by the function select logic informs the device of the transaction. Input data can be removed on the trailing edge of this pulse.

4.8.2.7 DROUTBUF Output Data Transfer — DROUTBUF is comprised of two 8-bit latches, enabling either 16-bit word or 8-bit byte output transfers. Two SEL 2 signals function as clock signals for the latches. When in a DATO bus cycle, both signals clock data from the internal BRD0-15 H bus into the latches. However, when in a DATOB cycle, only one signal clocks data into an 8-bit latch, as determined by address bit 0 previously stored during the addressing portion of the bus cycle.

The NEW DATA READY H pulse generated by the function select logic is sent to the user's device to inform the device of the data transaction. The data can be input to the device on the trailing edge of this pulse.

4.8.2.8 Interrupts — The DRV11 contains LSI-11 bus-compatible interrupt logic that allows the user's device to generate interrupt requests. Two independent interrupt request signals (REQ A H and REQ B H) are capable of requesting processor service via separate interrupt vectors. In addition, DRCSR contains two interrupt enable bits (INT EN A and INT EN B) (bits 6 and 5, respectively), which independently enable or disable interrupt requests. REQ A and REQ B status can be read by the processor in DRCSR bits 7 and 15, respectively. Since separate interrupt vectors are provided for each request, one of the requests could be used to imply that device data is ready for input and the remaining request could be used to imply that the device is ready to accept new data.

An interrupt sequence is generated when a DRCSR INT EN bit (A or B) is set and its respective REQ signal is asserted by the device. The processor responds (if its PS bit 7 is not set) by asserting BDIN L; this enables the device requesting the interrupt to place its vector on the BDAL bus when the interrupt request is acknowledged. The processor then asserts BIAKO L, acknowledging the interrupt request. The DRV11 receives BIAKT L and the interrupt logic generates

VECTOR H, which gates the jumper-addressed vector information through the read data multiplexer and bus drivers and onto the LSI-11 bus. The processor then proceeds to service the interrupt request as described in Chapter 3.

4.8.2.9 Maintenance Mode — The maintenance mode allows the user to check DRV11 operation by installing an optional BCOSR cable between connectors J1 and J2. This maintenance cable allows the contents of the output buffer DROUTBUF to be read during a DRINBUF DATA bus cycle. In addition, interrupts can be simulated by using DRCSR bits CSR0 and CSR1. CSR1 is routed via the cable directly to the REQ B11 input and CSR0 is routed to the REQ A H input. By setting or clearing INT EN A, INT EN B, and CSR0 and CSR1 bits in the CRCSR register, a maintenance program can test the interrupt facility.

4.8.2.10 Initialization — BINIT 1 is received by a bus driver, inverted, and distributed to DRV11 logic to initialize the device interface. The buffered initialize signal is available to the user's device via the AINIT H and BINIT 11 signal lines. DRV11 logic functions cleared by the BINIT 11 signal include DROUTBUF, CRCSR (bits 0, 1, 5, and 6), and interrupt logic.

4.9 H780 POWER SUPPLY

4.9.1 General

The H780 power supply provides dc operating power to all backplane slots contained in a PDP-11/03 microcomputer system. Depending upon the configuration ordered, the primary power input is 115 or 230 Vac, 50 or 60 Hz. In addition to providing operating power, the H780 generates power supply status and line time clock signals which are distributed over the LSI-11 bus. Three LED indicators and three switches are on the H780's front panel. The indicators include RUN, which illuminates when the LSI-11 processor is in the run state, and DC ON, which illuminates when normal dc operating voltages are applied to the LSI-11 backplane. The DC ON indicator status is controlled by circuits contained in the H780. The DC ON/OFF switch allows the operator to turn off the H780 dc output voltages without turning off system primary power. This allows safe module installation or removal with no dc power applied to the backplane. A normal power-up/power-down sequence is produced when this switch is operated. The ENABLE/HALT switch enables the operator to manually assert the BHALT L bus signal, causing the LSI-11 microcomputer to execute the console (ODI) microcode. When in the ENABLE posi-

tion, program execution can be initiated via console ODI commands. The LIC ON/OFF switch enables or disables H780 generation of the line time clock (BEVNT L) signal. One spare LED indicator is included. Two fans provide cooling air for the H780 power supply and all modules contained in the PDP-11/03 enclosure.

The H780 features:

- $+5\text{ V} \pm 3\%$, 18 A (maximum) and $+12\text{ V} \pm 3\%$, 3.5 A (maximum); combined dc power must not exceed 120 W.
- Overcurrent/short circuit protection — Output voltages return to normal after removal of overload or short. Current limited to approximately 1.2 times the normal maximum rating.
- Overvoltage protection — $+5\text{ V}$ limited to $+6.3\text{ V}$ (approx); $+12\text{ V}$ limited to $+15\text{ V}$ (approx).
- Dual primary power configuration — Can be connected for nominal 115 V, 60 Hz or 230 V, 50 Hz input power.
- Efficiency — Switching regulator circuits provide greater than 65 percent overall efficiency.
- System control/indicator panel — A simple system control/indicator panel allows the user to control dc power on/off and microcomputer Run/Halt mode. Indicators display the actual dc power and processor status.
- Line Time Clock — A bus-compatible signal is generated by the power supply for the event (line time clock) interrupt input to the processor. This signal is either 50 or 60 Hz, depending upon primary power line frequency input to the power supply.
- Power Fail/Automatic Restart — Fault detection and status circuits monitor ac and dc voltages and generate bus-compatible BPOK H and BDCOK H signals (respectively) to inform the LSI-11 system modules of power supply status.
- Fans — Built-in fans provide cooling for the power supply and LSI-11 modules contained in the PDP-11/03 enclosure.

4.9.2 Specifications

Electrical

Input Voltage

100—127 V rms, 50 ± 1 Hz or 60 ± 1 Hz
200—254 V rms, 50 ± 1 Hz or 60 ± 1 Hz

Input Power (full load)

400 W maximum

Output Voltages

+5 V $\pm 3\%$, 0—18 A load (static and dynamic)
+12 V $\pm 3\%$, 0—3.5 A load (static and dynamic)
Maximum output power: 120 W (total)

Output Protection

Current limited to 1.2 times maximum normal rating (approximately)
Voltage +5 V and +12 V outputs limited to -6.3 V (nominal) and +15 V (nominal), respectively

Output Ripple

5 V output: Less than 100 mV pk-to-pk
12 V output: Less than 200 mV pk-to-pk

Output Regulation

Line: +5 V, 1.0% max
+12 V, 0.5% max
Load: (Static and dynamic ($\Delta I < 0.1$ A μ s))
+5 V, 1% max
+12 V, 0.5% max
Load Interaction: 1.0%

Load Term Stability

0.2% / 1000 hr max

Line Protection

H780A (115 V input): Fast blow 5 A fuse
H780B (230 V input): Fast blow 3 A fuse

Noise

AC component above 100 kHz meets DEC STD 102.7; H780B units will meet VDE N-12 limits for European environment.

Front Panel Control and Indicators

DC ON/OFF switch
RUN/HAULT switch
LTC ON/OFF switch
RUN indicator
DC ON indicator
Spare indicator

Rear Panel Controls and Indicators

AC ON/OFF power switch

Backplane Signals

BPOKH
BDCOKH
BEVNTL
BHALLL
SRUNL

Mechanical

Cooling

Two self-contained fans provide 200 LFPM air flow.

Size

5-1/2 in. w \times 3-1/2 in. h \times 14-5/8 in.

Weight

13 lbs

Environmental

Temperature

5°—50° C operating

Humidity

90% maximum without condensation

4.9.3 Functional Description

4.9.3.1 General—Major functions contained in the H780 power supply are shown in Figure 4-28. These functions include circuits which produce unregulated dc voltage and regulated dc voltage for H780 circuit operation, +5 V and +12 V switching regulators, overload and short-circuit protection, -5 V and -12 V crowbar (overvoltage protection) circuits, and logic signal generation circuits. The following paragraphs describe each of these functions in detail.

4.9.3.2 Unregulated Voltage and Local Power—Unregulated voltage and local power circuits provide operating dc power for power supply logic and control circuits, and dc power for the -5 V and +12 V regulator circuits. These circuits are shown in Figure 4-29. AC power is supplied to the H780 via an ac input plug and cable. A toggle switch mounted on the rear of the H780 assembly applies ac power to the power supply. Normally, this switch remains in the ON position, allowing ac power to be controlled by power distribution and control circuits in which the PDP-11/03 system is installed. Primary circuit overload protection is provided by a fuse mounted on the rear of the H780 unit. Primary power circuits are factory-wired for 115 Vac (model H780A) or 230 Vac (model H780B) operation. Power transformer primary windings and the two fans operate directly from the switched ac power.

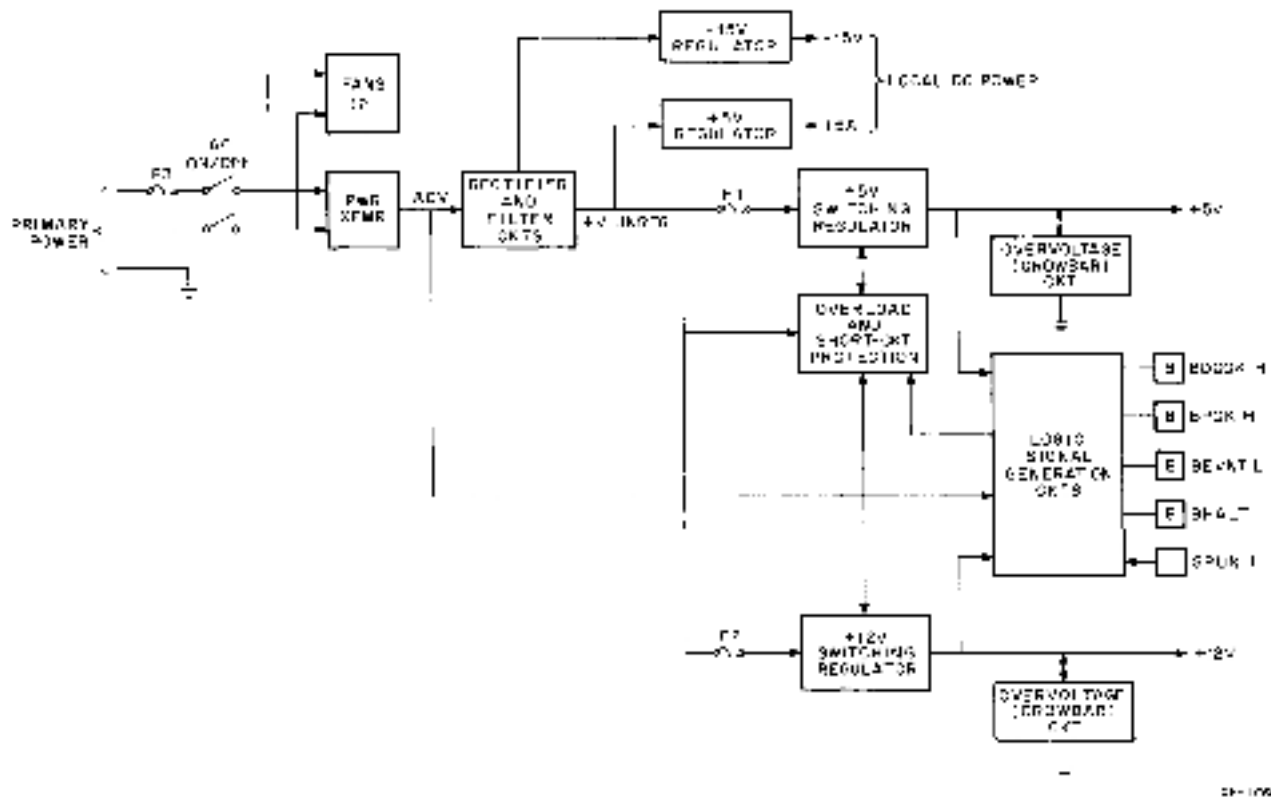

Figure 4-28 11780 Power Supply Block Diagram

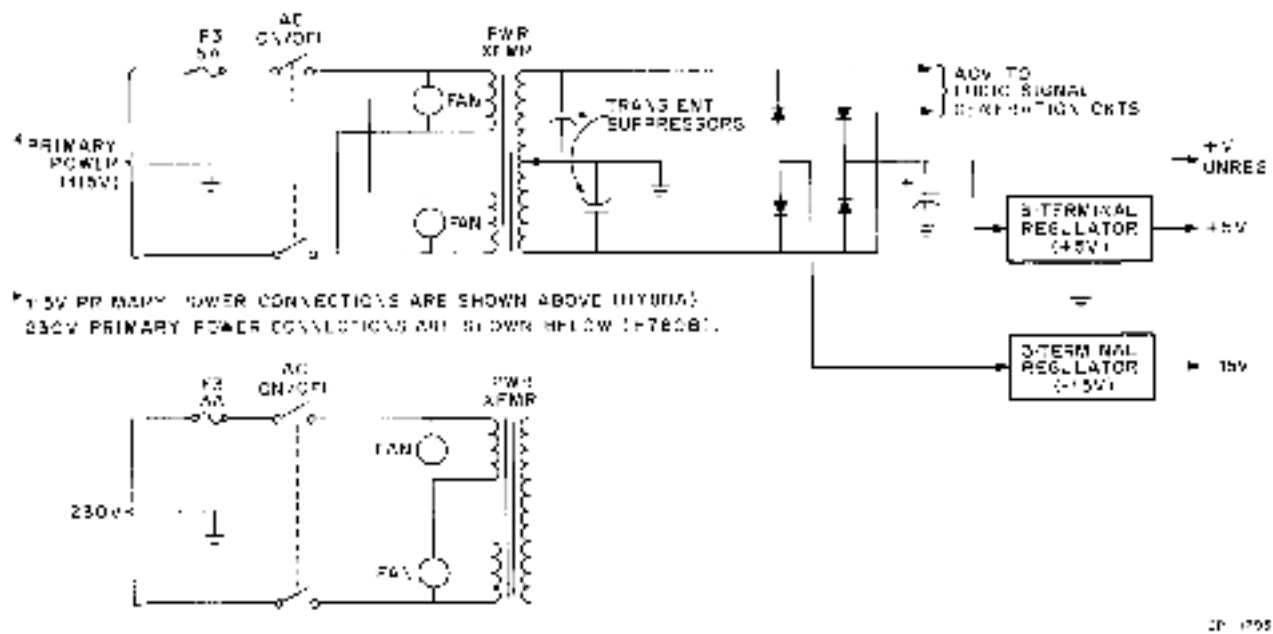

Figure 4-29 Unregulated Voltage and Local DC Power

A single center tapped secondary winding supplies power for regulator circuits and internal circuit operation. Conventional full-wave rectifiers and a -15 V, 3-terminal regulator IC provide regulated voltage for internal distribution. The rectifiers also provide -24 V (approx) for internal distribution and regulator operation. A 3-terminal regulator integrated circuit provides -5 V logic and control power for H780 circuits. The -5 V and -12 V regulators use the same +24 V unregulated voltage for regulation and distribution to LSI-11 modules. AC voltage from one side of the transformer secondary is also routed to the line time clock (LTC) circuit, which generates a BEVNT L bus signal for a line time clock processor interrupt. When used with a 60 Hz line frequency, the interrupt occurs at 16.667 ms intervals; a 50 Hz line frequency will produce interrupts at 20 ms intervals.

4.9.3.3 Basic Regulator Circuit — Both +5 V and +12 V regulator circuits receive the +24 V unregulated input power. The +5 V and +12 V regulator circuits are identical except for component values. Hence, only the basic +5 V regulator is described in detail.

The basic regulator is a switching regulator which operates at approximately 20 kHz. The main controlling element is a 3-terminal regulator which

operates at approximately the regulated output voltage level. Basic regulator circuits are shown in Figure 4-30. Note that the ground terminal of the 3-terminal regulator is connected to a potentiometer, allowing factory adjustment of the terminal voltage over a -0.7 to +0.5 V range. Hence, the 3-terminal regulator output in the +5 V regulator circuit can range from 4.3 to 5.4 V (approx).

Normal switching regulator operation is accomplished when the control transistor is turned on. Forward bias for the control transistor is supplied via R14. It is turned off only during fault conditions (overcurrent or shorted output voltage) or when the input ac line voltage is below specifications. Its emitter supplies unregulated voltage to the 3-terminal regulator. At less than 50 mA regulator output current (approx), the 3-terminal regulator supplies the output voltage. However, as load current through the 3-terminal regulator is increased beyond this value, the voltage drop across R27 forward biases the driver transistor. The pass switch transistor then turns on and applies the unregulated +24 V to L2. The output capacitor then charges toward the +5 V value, current limited by the inductance of L2. When the output voltage rises to the 3-terminal regulator regulation voltage, the 3-terminal regulator turns off; current through R27 stops, and the

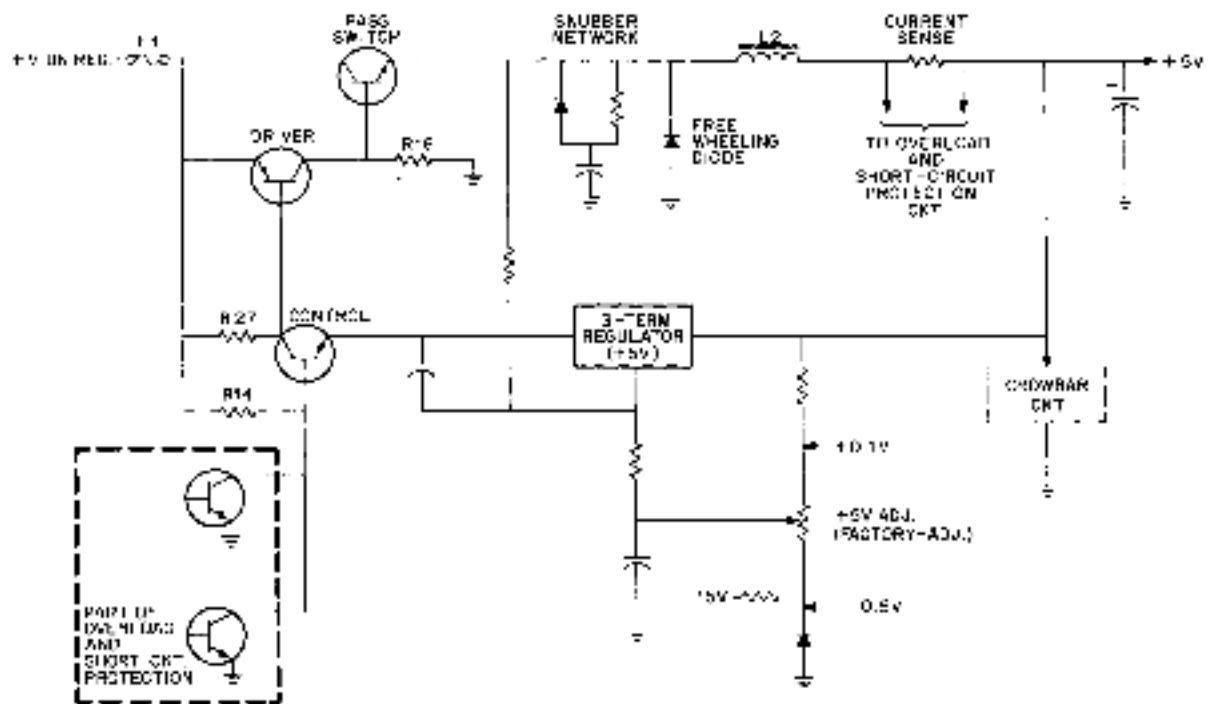

Figure 4-30 Basic Regulator Circuit

driver transistor is not forward biased. Hence the driver and pass switch transistors cut off. The energy stored in L_2 continues to charge the capacitor bank slightly beyond the designed output voltage via the free-wheeling diode and the current sense resistor. Once the inductor's stored energy is spent, the load discharges the output capacitor until the output voltage drops below the 3-terminal regulator's regulation voltage. At that point, current through R_{27} increases and turns on the driver and pass switch transistors, and the cycle repeats. Note that as the load is increased, the pass switch must remain on longer in order to charge the output capacitor to the regulated voltage value. This process repeats at a 12–20 kHz rate, producing the switching regulator operation.

Switching losses in the pass switch transistor are minimized by the snubber network. This network operates during the "off" switching transient (as the pass switch is biased off) by controlling the rate of increasing collector-to-emitter voltage as collector current decreases.

The control transistor is turned off during a fault condition by overload and short-circuit protection circuits. When a fault condition is detected, the control transistor's base voltage drops to nearly 0 V, causing it to cut off. When cut off, operating voltage is removed from the 3-terminal regulator and R_{27} current is 0, disabling the switching regulator circuit.

4.9.3.4 Overload and Short-Circuit Protection — Each 11780 dc output is overload and short-circuit protected. When in an overload condition, excessive power supply current is sensed, causing both switching regulators to go off and then cycle on and off at a low-frequency rate (approximately 7.5 Hz) until the overload is removed. Each time the power supply cycles on, the circuit checks for the overload condition. If the load current returns to normal, the 20 kHz switching regulator operation resumes.

Overcurrent sensing circuits for -5 V and $+12$ V dc outputs are identical except for component values. A 5 V power supply overcurrent condition results in an increased voltage drop across the current sense resistor (Figure 4-31), forward biasing the current sense transistor. (During normal operation, this transistor is not forward biased.) Current sense transistor collector voltage then drops from the normal $+24$ V (approx) to the $+5$ V regulator output value; this voltage, which is less than the -16 V reference applied to the current limit comparator's inverting input, is diode-coupled to the comparator's non-inverting input, causing the comparator's output to go low; the diode coupling provides an OR logic function for both -5 V and $+12$ V overcurrent fault conditions. The comparator's low output signal triggers the 20 μ s one-shot whose OVERCURRENT 1 pulse output triggers the 1.35 ms one-shot and sets the Current Limit flip-flop. The OVERCURRENT 1 pulse is also ORed with the

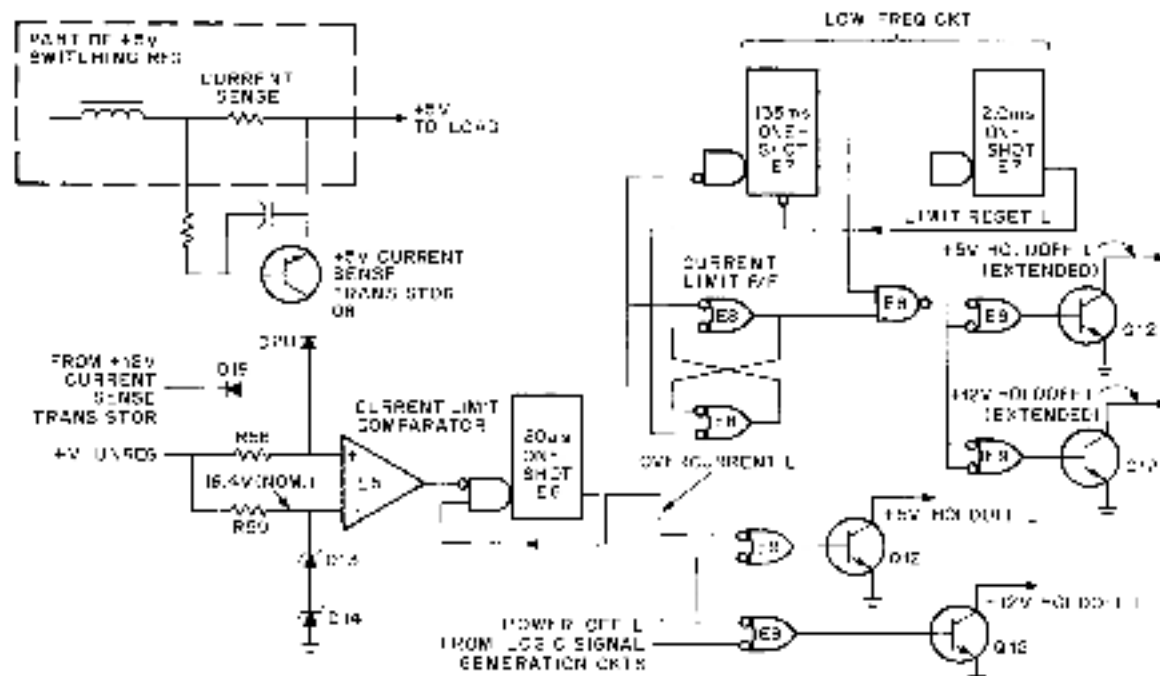

Figure 4-31 Overload and Short-Circuit Protection

CP 1795

POWER OFF L signal, turning on the +5 V and +12 V hold-off transistors. Both switching regulators are then disabled. The high 135 ms one-shot output pulse is ANDed with the Current Limit flip-flop output, turning on -5 V and +12 V extended hold-off transistors. Hold-off signals remain in this state and inhibit switching regulator operation for the 135 ms pulse duration. At the end of this time, the 135 ms one-shot resets, terminating the delayed hold-off signals, and triggers the 2.0 ms one-shot. Its active low output resets the Current Limit flip-flop and clears the 135 ms one-shot for 2.0 ms, allowing the regulator pass switch transistors to operate for 2 ms (minimum). At the end of this time, the 135 ms one-shot is again enabled (the clear input goes high) and a new over-current cycle is enabled. If the overload is removed, normal operation resumes; otherwise, the overload causes a new overload condition to occur and the cycle repeats, as described above.

Switching regulator operation is suspended when the operator places the DC ON/OFF switch in the OFF position. Logic signal generation circuits respond by immediately asserting BPOK H low to initiate a processor power-fail sequence. After a 5-10 ms "pseudo delay," POWER OFF L is asserted low. This low signal is wire-ORed with OVERCURRENT L, inhibiting the switching regulator operation, and dc power is removed from the backplane.

4.9.3.5 Crowbar Circuits — Crowbar circuits are connected across both +5 V and +12 V power supply outputs for overvoltage protection. An overvoltage condition could occur if +12 V and +5 V outputs shorted together, or if a driver or switch transistor becomes shorted. When shorted to a higher voltage source, the crowbar fires, shorting the supply voltage that it is protecting to ground (dc return). In this condition, the overload and short-circuit protection circuits respond by limiting the duty cycle of the switch transistor until the overvoltage source is removed. However, when the overvoltage is caused by a shorted driver or switch transistor, short-circuit protection is ineffective, and the excessive current caused by the crowbar circuit firing will blow the regulator's fuse (F1 for +5 V or F2 for +12 V).

The crowbar circuit for the -5 V output is shown in Figure 4-32. It comprises a 5.6 V zener diode D8, diode D5, programmable unijunction transistor Q9, and silicon controlled rectifier (SCR) Q15. R19, D8, and D9 supply the 6.1 Vdc (approx) crowbar reference (threshold) voltage to the gate of Q9 via R21. Q9 is normally off and its cathode supplies a 0 V gate input to

Q15. An overvoltage is coupled into the circuit via C7, causing the gate voltage of Q9 to rise; this triggers Q9 and its cathode voltage rises to the output (overvoltage) potential. Q15 then fires and shorts (crowbars) the supply output. The circuit remains in this condition until the overvoltage is removed (Q15 current goes to zero) and either the power supply switch transistor is off due to short circuit protection, or the regulator's dc fuse opens.

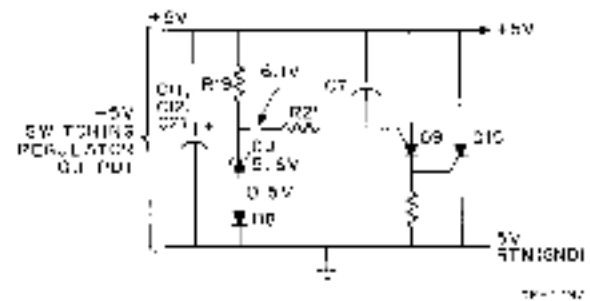

Figure 4-32 Crowbar Circuit

The +12 V crowbar circuit functions in a similar manner. However, the reference voltage for this power supply is approximately 13.5 V.

4.9.3.6 Logic Signal Generation — Logic signal generation circuits produce LSI 11 bus signals for power normal/power fail and line time clock interrupt functions and processor Run-Enable/Halt mode. The RUN indicator circuit monitors the SRUN L backplane (nonbused) signal and provides an active display when the processor is in the Run mode. BPOK H and BDCOK H indicate power status. When both are high, power to the LSI 11 bus is normal and no power fail condition is pending. However, if primary power goes abnormally low (or is removed) for more than 16.5 ms, BPOK H goes low and initiates a power-fail processor interrupt. If the power fail condition continues for more than an additional 4 ms, a "pseudo delay" circuit causes BDCOK H to go low. The circuit also causes the overload and short-circuit protection circuit to inhibit -5 V and +12 V control transistors; normal output voltages are available for 50 μ s (minimum) after BDCOK H goes low (depending on the loading of the dc output voltages). The DC ON/OFF switch simulates an AC ON/OFF operation by turning switching regulators on or off without turning system primary power off. A normal power up/power-down sequence is produced by this circuit. The line time clock circuit produces a processor interrupt at the power line frequency (either 50 or 60 Hz). The circuit simply asserts the BEVNT L line at the line frequency.

DC voltage monitor circuits respond to both -5 V and $+12\text{ V}$ power supply outputs. A $+2.5\text{ V}$ reference at the voltage comparator's noninverting input is established by 15 A and a voltage divider comprised of

$R25$ and $R3$, as shown in Figure 4-33. Voltages are sensed at the anodes of diodes $D17$ and $D18$. The cathode of $D17$ is connected directly to the $+5\text{ V}$ output. $D18$ is connected to a voltage divider

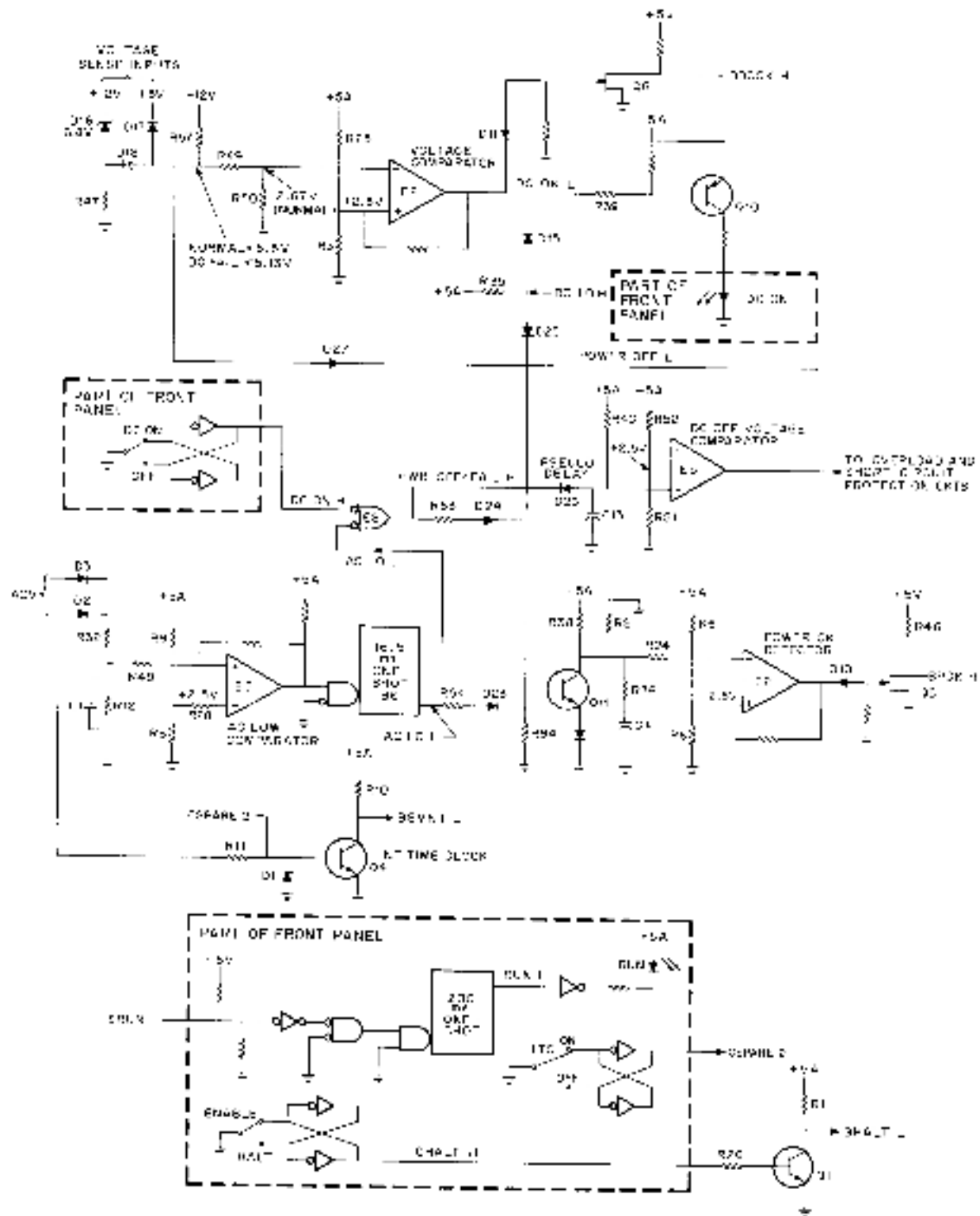

Figure 4-33 Logic Signal Generation

4-108

comprising 6.8 V zener diode D16 and R47. The sensed voltage is always 6.8 V less than the +12 V power supply output voltage (but not less than 0 V). Normally, the junction of D17, D18, R57, and R49 is clamped to +5.5 V (nominal) via D17, which is connected to the +5 V output. Voltage divider R49 and R50 provide a portion of the sensed voltage to the comparator's inverting input. This voltage is normally 2.7 V, causing the comparator's output to go low. The low signal forward biases DC ON panel indicator driver transistor Q10, producing a DC ON indication, and reverse biases the BDCOK H FET bus driver Q6. As a result, Q6 cuts off, and its source voltage rises to +5 V, producing the active BDCOK H signal.

A low +5 V output results in a decrease in voltage at the voltage comparator's inverting input. A voltage less than 4.6 V reduces the voltage at the comparator's inverting input to less than the -2.5 V reference. Hence, the comparator's output goes high, turning off the DC ON indicator and allowing Q6 to conduct. Q6 asserts the BDCOK H bus signal low, indicating that a dc power-fail condition exists.

The low +12 V operation is similar to that described for low +5 V operation. An output voltage less than 11.3 V results in BDCOK H being asserted low (power-fail condition).

AC voltage monitor circuits include an ac low comparator, 16.5 ms delay, and a BPOK H bus driver circuit which is enabled only when BDCOK H is in the

active (dc voltage normal) state. Rectifiers D2 and D3 produce positive-going dc voltage pulses at twice the ac line frequency. R32, R12, and C1 produce nominal +3.9 V (peak) normal line voltage pulses which are coupled to the noninverting input of the ac low comparator via R48. R8 and R9 produce a +2.5 V reference for the comparator's inverting input. The comparator's normal output is a series of pulses occurring at twice the ac power line frequency. Each positive-going leading edge retriggers the 16.5 ms one-shot, keeping it in the set state. The 16.5 ms one-shot output is diode-ORed with DCOK L via diodes D25 and D23 and PWR OFF/FAIL H via D24. Normally, the three signals are low and Q11 remains cut off. In this condition, C4 charges to +3.125 V via R36 and R38. This signal is then applied to the power OK comparator's inverting input via R24. Since the noninverting input is referenced to -2.5 V by voltage divider R5 and R6, the comparator's output goes low, biasing off FET Q5. Q5's source voltage then rises toward +5 V via R46 producing the active BPOK H signal. Power-up/power-down sequence timing is shown in Figure 4-34.

A power failure is first detected when the pulsating dc voltage at the ac low comparator's noninverting input is less than +2.5 V (peak). The comparator's output then remains low, allowing the 16.5 ms one-shot to go out of the retrigger mode. The one-shot resets 16.5 ms after the leading edge of the last valid ac voltage alternation; the 16.5 ms delay is equivalent to a full line cycle (two-alternation) failure. The high one-shot

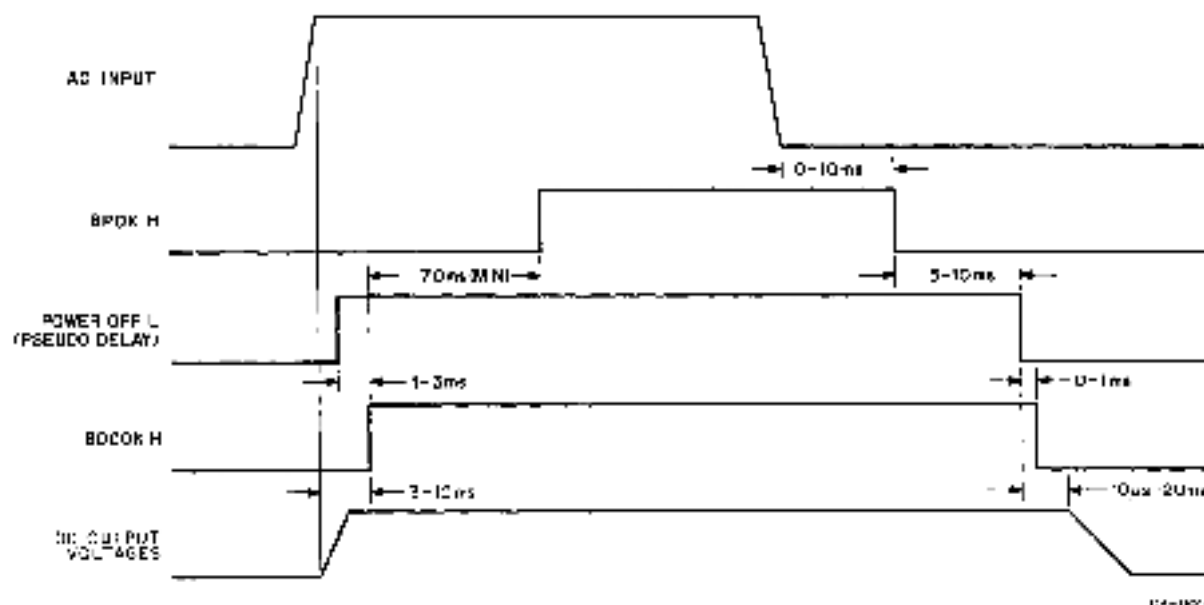

Figure 4-34 Power-Up/Power-Down Sequence

output is then coupled via D23 to the base of Q11, forward biasing it. Q11 conducts and rapidly discharges C4; R36 limits peak discharge current. The low voltage thus produced is less than the +2.5 V reference at the power OK comparator's input, and its output goes high. Q5 then conducts and asserts the BPOK H signal low (power fail). The AC LO L signal produced by the 16.5 ms one-shot is ORed with the DC ON H signal, producing a high POWER OFF/FAIL H signal. This signal reverse biases D26, allowing C13 to charge to 5 V via R40. After a 5—10 ms (approximately) "pseudo delay," C13's voltage rises above the dc off voltage comparator's +2.5 V reference (noninverting) input. The comparator's output goes low, asserting POWER OFF L low and turning off the switching regulator (Paragraph 4.9.3.4).

When normal power is restored, the 16.5 ms one-shot returns to the retrigger (set) mode. AC LO L goes high (false) and PWR OFF/FAIL H goes low, discharging C13. The dc off voltage comparator's inverting input immediately goes low and its output goes high, enabling switching regulator operation. The low AC LO H one-shot output removes forward bias from the base of Q11, cutting it off. Its collector voltage then rises as C4 charges at a relatively slow rate. R38 controls the charging rate of C4 and ensures that ac voltage and dc output voltages are normal for approximately 100 ms (70 ms minimum) before BPOK H goes high.

The DC ON/OFF switch simulates a power failure when it is placed in the OFF position. Cross-coupled inverters provide switch debounce protection and a low

(false) DC ON H signal is produced. This signal is ORed with AC LO L, causing a power-fail sequence to occur as previously described. BPOK H is immediately asserted low. After the 5—10 ms pseudo delay, dc switching regulator operation is inhibited and dc power is removed from the backplane. When the DC ON/OFF switch is returned to the ON position, PWR OFF/FAIL H goes low, rapidly discharging C13. POWER OFF L then goes high and switching regulator operation resumes. Approximately 100 ms later, BPOK H goes high and normal processor operation is enabled. DC ON/OFF circuit timing is shown in Figure 4.35.

BEVNT L is the bused interrupt request line which is normally used for line clock interrupts. Q4 is forward-biased during positive alternations of the ac line and produces low-active BEVNT L signals. D1 clips negative alternations and limits Q4's reverse base to emitter voltage. The LTC ON/OFF switch must be in the ON position for BEVNT L signal generation. When the LTC function is not desired, the LTC switch is set to the OFF position; CS/PARE2 goes low, Q4 remains cut-off, and BEVNT L remains passive (high).

The RUN indicator is illuminated whenever the processor is executing programs. SRUN L, a non-bused backplane signal, is a series of pulses which occur at 3—5 μ s intervals whenever the processor is in the Run mode. The pulses trigger a 200 ms one-shot on each SRUN L pulse leading edge, keeping it in the retrigger

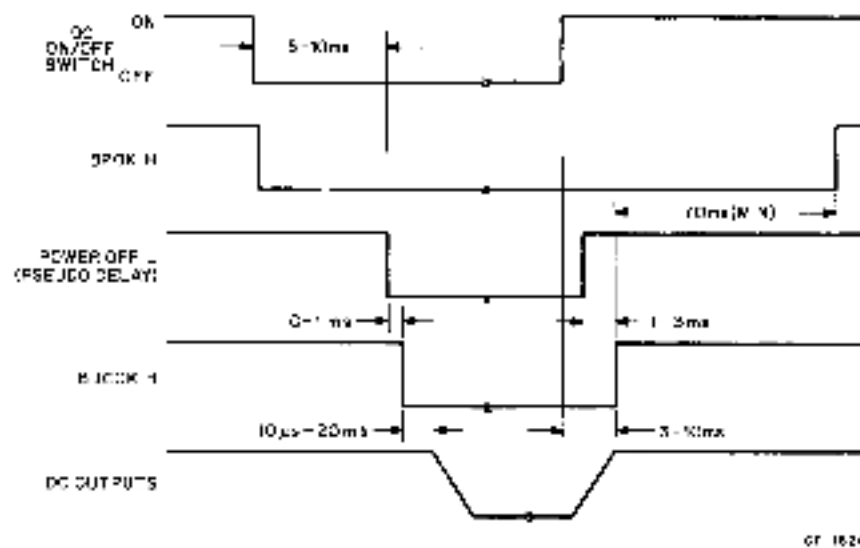

Figure 4-35 DC ON/OFF Circuit Timing

mode. Its high RUN H output signal is then inverted, producing a 0 V signal that turns on the RUN indicator. When the processor is in the Halt mode, SRUN L pulses cease and the 200 ms one-shot resets after the 200 ms delay. The RUN indicator turns off, indicating the Halt mode.

The HALT/ENABLE switch allows the operator to manually assert the BHALT L signal low, causing the processor to execute console ODT microcode. When in the ENABLE position, BHALT L is not asserted, and the Run mode is enabled. Cross-coupled inverters provide a switch debounce function.

4.9.4 H780 Connections

H780 connections are shown in Figure 4-36. The H9270 backplane connections and interconnecting cables are also shown. Note that cable connectors are wired 1:1. Both connectors on the H780/H9270 signal cable are wired in exactly the same manner, as listed in Figure 4-36. Similarly, both ends of the panel signal/power cable are wired to 16-pin connectors in the same pin/signal configuration.

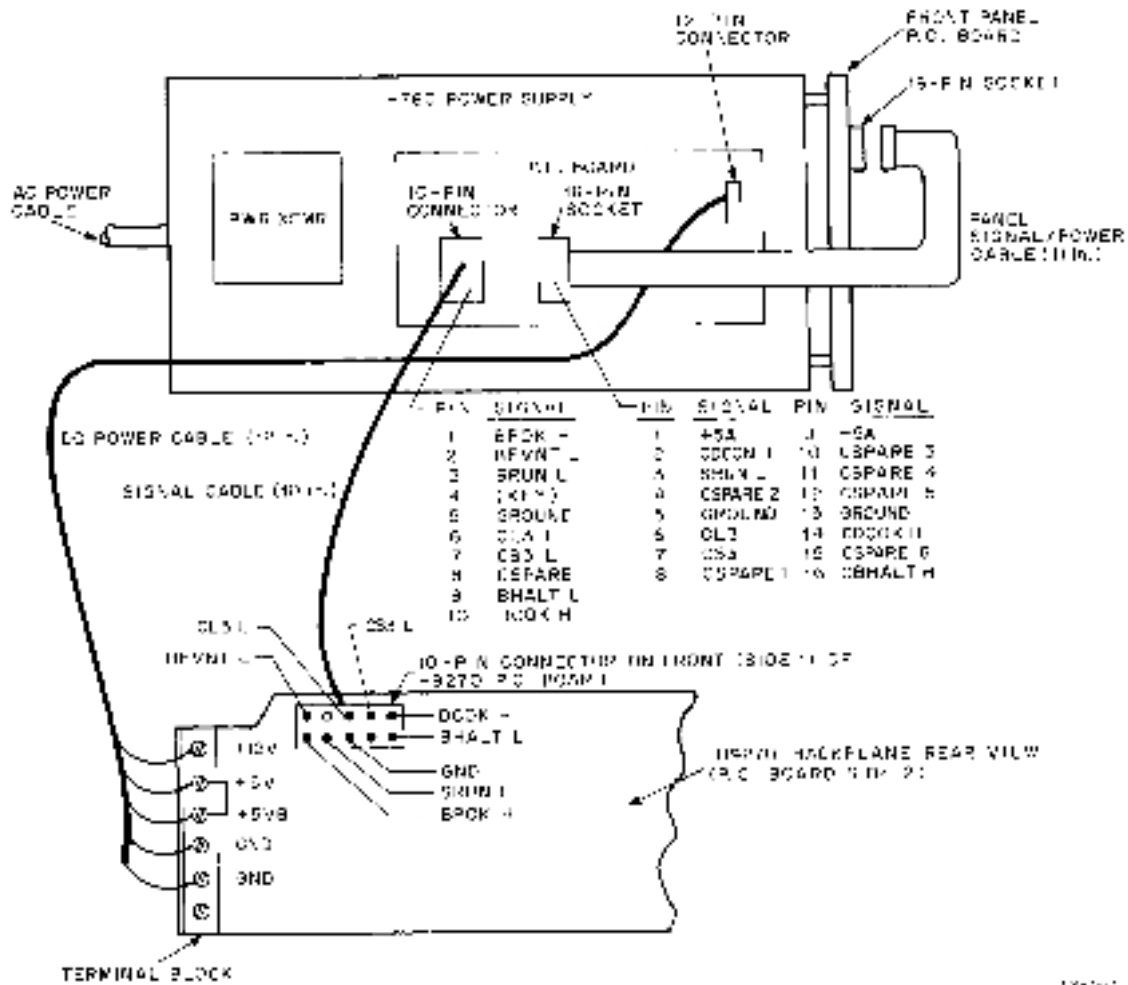

Figure 4-36 H780 Connections

CHAPTER 5

USING KD11-F and KD11-J PROCESSORS

5.1 GENERAL

Before installing and using the KD11-F or KD11-J processor in the LSI-11 or PDP-11/03 system, the user must select certain processor features (jumper-selected), determine where the processor and option modules should be installed on the backplane, be aware of trap and interrupt functions, and ensure the conditions for bus initialization. These items are discussed in detail in the following paragraphs.

5.2 JUMPER-SELECTED FEATURES

5.2.1 General

Wire-wrap posts are provided on the LSI-11 micro-computer module to allow the user to select various features, as listed in Table 5-1. These features include: memory refresh enable/disable, line time clock (LTC, or external event interrupt) enable/disable, power-up mode selection, and resident memory bank selection (KD11-F only). Jumpers are located as shown in Figure 5-1. Jumpers are factory-installed as listed in Table 5-2 and can be altered by the user for a particular application, as described in the following paragraphs.

Table 5-1
Summary of KD11 Jumpers

W1	W2	W3	W4	W5	W6	Function
X	X	X	R	X	X	Memory Refresh
X	X	R	X	X	X	Line Time Clock Enable
X	X	X	X	R	R	Power-Up to 24
X	X	X	X	I	R	Power-Up to ODT
X	X	X	X	R	I	Power-Up to 173000
X	X	X	X	I	I	Power-Up to special microcode
R	I	X	X	X	X	Resident Memory Bank 0
I	R	X	X	X	X	Resident Memory Bank 1

NOTE

- X — Don't Care
- I — Installed
- R — Removed

Table 5-2
KD11 Factory Jumper Configuration

Jumper	Installed	Removed	Function
W1		X	BANK 1 Disabled
W2	X (KD11-J)	X (KD11-F)	BANK 0 Enabled (KD11-F only)
W3		X	Line Time Clock Enable
W4	X (KD11-J)	X (KD11-F)	Memory Refresh Enable (KD11-F only)
W5		X	Power-Up Mode 0
W6		X	

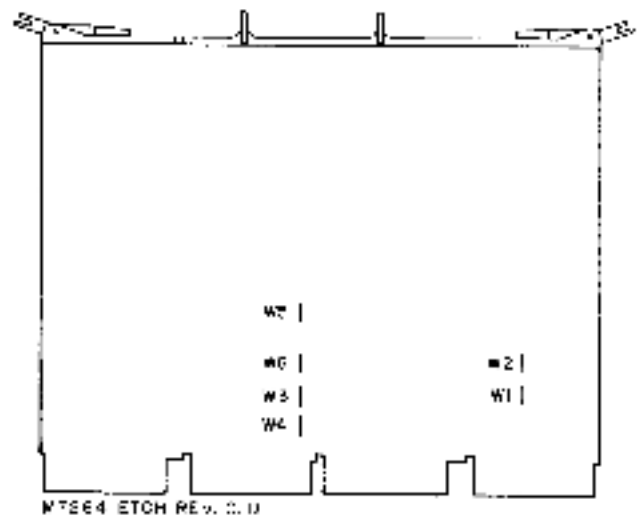

NOTE

W1 through W6 are wire-wrap jumpers.

Figure 5-1 Jumper Locations

5.2.2 Memory Refresh

The LSI-11 processor has the capability of completely controlling the refreshing of all dynamic MOS memories in a system when jumper W4 is removed. Memory refresh is always required when dynamic MOS memory devices are used in the LSI-11 system.

such as the KD11-F resident memory and the MSV11-B 4K by 16-bit read/write memory module. The refresh operation can be controlled by a device other than the LSI-11 processor, if available, such as a DMA refresh device. If such a device is used, or if no dynamic MOS memory devices are present in the system (KD11-J), install W4. The refresh sequence is described below.

The processor's memory refresh sequence is controlled by resident microcode in the processor which is initiated by an interrupt that occurs once ever 1.6 ms. It is the highest priority processor interrupt. Once the sequence is initiated, the processor will execute 64 BSYNC L/BDIN L bus transactions while asserting BREF L. The BREF L signal overrides memory bank address bits 13–15 and allows all memory units to be simultaneously enabled. After each bus transaction, BDALI–6 L is incremented by 1 until all 64 rows have been refreshed by the BSYNC L/BDIN L transaction. This process takes approximately 130 μ s during which external interrupts (BIRQ L and BEVNT L) are ignored. However, DMA requests can be granted between each of the 64 refresh transactions.

5.2.3 Line Time Clock

LTC (or external event) interrupts are enabled when jumper W3 is removed and the processor is running. The jumper can be inserted to disable this feature. The LTC interrupt is initiated by an external device when it asserts the BEVNT L signal. This is the highest priority external interrupt request; processor interrupts have higher priorities. If external interrupts are enabled (PS bit 7 = 0), the processor PC (R7) and PS word are pushed onto the processor's stack. The LTC (or external event device) service routine is entered by vector address 100; the usual interrupt vector address input operation by the processor is not required since vector 100 is generated by the processor.

The first instruction of the service routine will typically be fetched within 16 μ s from the time BEVNT L is asserted; however, if optional LIS/FIS instructions are being executed, this time could extend to 50.45 μ s. This time could also be extended by processor trap execution (memory refresh, T-bit, power fail, etc.), or by asserting the BHALT L signal.

5.2.4 Power-Up Mode Selection

Since the LSI-11 can be used in a variety of system applications that have either (or both) volatile (semiconductor read/write) or nonvolatile (PROM or core) memory, one of four power-up mode features are available for user selection. These are selected (or changed) by wire-wrap jumpers W5 and W6 on the

KD11-F or KD11-J processor (M7264) module. Note that the jumpers affect only the power-up mode (after BDCOK H and BPOK have been asserted); they do not affect the power-down sequence.

The state of the BHALT L signal is significant during the power-up sequence. When this signal is asserted, it causes the processor's ODT console microcode (a subset of an Octal Debugging Technique program) to become invoked after the power up sequence. The console device must be properly installed for correct use of the BHALT L signal.

The power-up modes are listed in Table 5-3. Detailed descriptions of each mode are provided in the paragraphs which follow.

Table 5-3
Power-Up Modes

Mode	Jumpers		Mode Selected
	W6	W5	
0	R	R	PC at 24 and PS at 26, or Halt mode
1	R	I	ODT Microcode
2	I	R	PC at 173000 for user bootstrap
3	I	I	Special processor microcode (not implemented)

NOTE

R = Jumper Removed

I = Jumper Installed

Power-Up Mode 0

This option places the processor in a microcode sequence that fetches the contents of memory locations 24 and 26 and loads their contents into R7 and the PS, respectively. A microcode service translation at this point interrogates the state of the BHALT L signal: depending on the state of this signal, the processor either enters ODT microcode (BHALT L asserted low) or begins program execution with the current contents of R7 as the starting address (BHALT L not asserted).

Note that the T-bit (PS bit 4) is loaded with the contents of PS bit 4 in location 26. This mode should be used only with nonvolatile memory locations 24 and 26 or with BHALT L asserted. This power-up sequence is shown in Figure 5-2.

Power-Up Mode 1

This mode immediately places the processor in the console microcode regardless of the state of the BHALT L signal. This mode assumes a console interface device at bus address 177560.

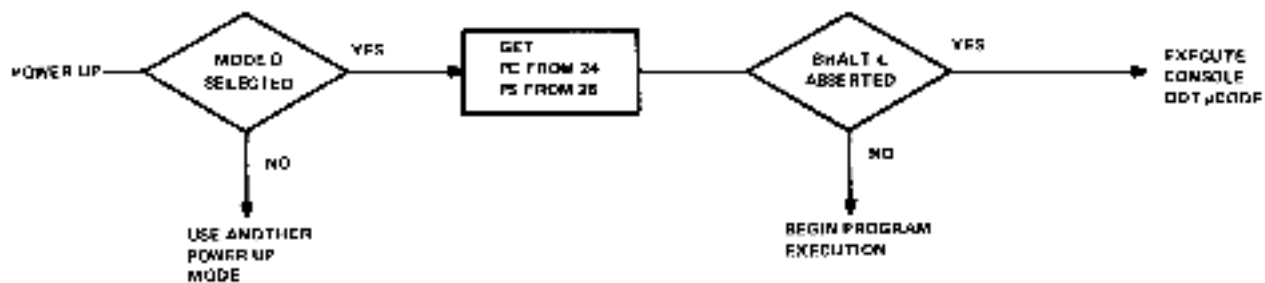

11-2165

Figure 5-2 Mode 0 Power-Up Sequence

Power-Up Mode 2

This mode places the processor in a microcode sequence that loads a starting address of 173000 into R7 and begins program execution at this location if the BHALT L signal is not asserted.

Note that before 173000 is loaded into R7, PS bit 4 (T-bit) is cleared and bit 7 (interrupt disable) is set. The user's program must set these bits, as desired, and

set up a valid stack pointer (R6). This option should be used with nonvolatile memory (ROM, PROM, or core) at address 173000. A time-out trap through location 4 will occur if no device exists at location 173000.

If BHALT L is asserted, the processor will not execute the instruction at location 173000 and will immediately execute the console microcode. This power-up mode sequence is shown in Figure 5-3.

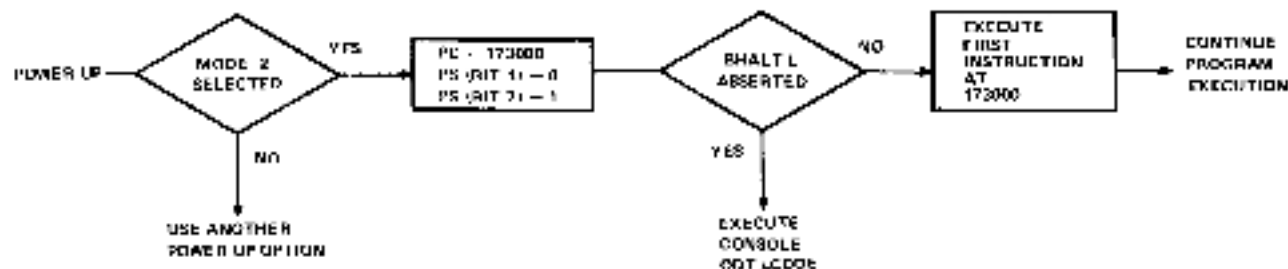

11-2157

Figure 5-3 Mode 2 Power-Up Sequence

Power-Up Mode 3

This microcode sequence allows access to future microcode expansion in the fourth microm page (microlocations 3000 to 3777). After RDCOK H and BPWROK H are asserted and the internal flags are cleared, a microjump is made to microlocation 3002. If this option is selected and no microm responds to the fourth page microaddress, a microtrap will occur through microlocation 0 which will, in turn, cause a reserved user instruction trap through location 10.

Note that the state of BHALT L is not checked before control is transferred to the fourth microm page.

5.2.5 Resident Memory 4K Address Selection

Jumpers W1 and W2 are used for selecting the 4K (bank) address for the KD11-F resident memory. Only one jumper must be installed, as follows.

W1 installed = Bank 1 (addresses 20000–37776)

W2 installed = Bank 0 (address 0–17776)

NOTE

If no jumper is installed, the 4K resident memory will not respond to any address.

5.3 INSTALLATION

Prior to installation, the processor module jumpers must be configured as directed in Paragraph 5.2. PDP-11/03 systems are shipped from the factory with the KD11-F or KD11-J processor installed. Refer to Chapter 11 for LSI-11 processor module installation details.

5.4 USING THE LSI-11 MICROCOMPUTER

5.4.1 General

Most of the operational characteristics are discussed in the *LSI-11, PDP-11/03 Processor Handbook* and related software publications. This discussion includes the use of the LTC (external event interrupt) feature, bus initialization, and trap and interrupt priority.

5.4.2 Interrupt and Trap Priority

Interrupts and traps are quite similar in their operation. Interrupts are service requests from devices external to the processor; traps are interrupts which are generated within the processor. Their main operational difference, however, is that external interrupts can only be recognized when PS priority bit 7 is zero; traps can be executed at any time, regardless of the PS priority bit status.

The highest priority trap is memory refresh, when enabled (Paragraph 5.2.2). Memory refresh does not require an interrupt vector since it is entirely controlled by processor microcode; memory refresh operations are completely transparent to the user programs and PS bits are not altered in any way. The remaining traps, including EMT, BPT, IOI, and TRAP instructions, and hardware-generated Trace Trap, Bus Error, Power Fail, etc. are described in the *LSI-11, PDP-11/03 Processor Handbook*. The LTC (external event) interrupt has the highest priority of all external interrupts, when enabled (Paragraph 5.2.3). It is acknowledged (served) only when PS priority bit 7 = 0. This interrupt always uses vector address 100. It loads a new PC from location 100 and a new PS from location 102. All other external interrupts are requested by a device asserting the BIRQ L signal. If PS bit 7 = 0, the request is acknowledged and the processor inputs a user-assigned vector address for the device's service routine PC (starting address) and PS. For example, when the requesting device is the console device, vectors 60 (console input) or 64 (console output) are used. These vectors are reserved for the console device by most DIGITAL software systems.

5.4.3 Halt Mode

The LSI-11 microcomputer can operate in either a Run or Halt mode. When in the Halt mode, normal program execution is not performed and the processor executes ODT console microcode. However, the processor will execute memory refresh in a normal

manner and arbitrate DMA requests; all external interrupts are ignored.

The Halt mode can be entered in one of four ways:

1. When the BHALT L signal is asserted.
2. When a HALT instruction has been executed.
3. By power-up sequence.
4. When a double bus error has occurred [a bus error trap with SP (R6) pointing to non-existent memory].

The LSI-11 microcomputer does not use conventional control panel lights and switches. Instead, the ODT console microcode routine provides all control panel features on a peripheral device which can be interfaced at bus address 177560 and interpret ASCII characters. In a typical configuration there is no bus device that responds to address 177570 (the PDP-11 SWR address). The peripheral device used with the ODT console microcode is called the console device, which can be any device capable of interpreting ASCII characters. The prompt character sequence and detailed use of console ODT commands are contained in the *LSI-11, PDP-11/03 Processor Handbook*.

5.5 INITIALIZATION AND POWER FAIL

Initialization occurs during a power-up or power-fail sequence, or when a RESET instruction is executed. The processor responds to these conditions by asserting the BINIT L bus signal. BINIT L can be used to clear or initialize all device registers on the bus. In addition, the DRV11 parallel line unit applies the buffered initialize signal to pins on both of its device interface connectors for initializing the user's device.

During the power up sequence, the processor asserts BINIT L in response to a passive (low) power supply-generated BDCOK H signal. When BDCOK H goes active (high), the processor terminates BINIT L and the jumper selected power up sequence is executed. Similarly, if power fails, the power supply-generated BPOK H signal goes passive (low) and causes the processor to push the PC and PS onto the stack and enter a power fail routine via vector location 24. The processor will execute a user power fail routine until either BDCOK H goes passive (low), indicating that de operating power may not sustain processor operation, or BPOK H returns to the active state. BINIT L will go active if BDCOK H goes passive.

Note that if a HALT instruction is executed after entering the power-fail routine, the ODT microcode will not be executed until BPOK H is reasserted. If BPOK H goes passive while the processor is in the Halt mode, the power-fail routine will not be executed.

CHAPTER 6

LSI-11 INTERFACE MODULES

6.1 GENERAL

Two LSI-11 interface modules provide a simple means for interfacing peripheral devices to the LSI-11 bus. The DLV11 is an asynchronous serial line interface that is capable of transmitting and receiving 20 mA current loop or EIA serial data, ranging in rate from 50 to 9600 baud. Two optional cable types are available for connecting 20 mA or EIA devices to the DLV11. The DRV11 is a general purpose parallel line interface. It is capable of storing and transmitting either two 8-bit bytes or one 16-bit word, and receiving 8-bit bytes or 16-bit words.

The remainder of this chapter describes DLV11 and DRV11 functions, jumpers, installation, interfacing to peripherals, and programming.

6.2 DLV11 SERIAL LINE UNIT

6.2.1 General

The DLV11 Serial Line Unit interfaces serial I/O devices to the LSI-11 bus, as shown in Figure 6-1.

6.2.2 Jumper-Selected Addressing, Vectors, and Module Operations

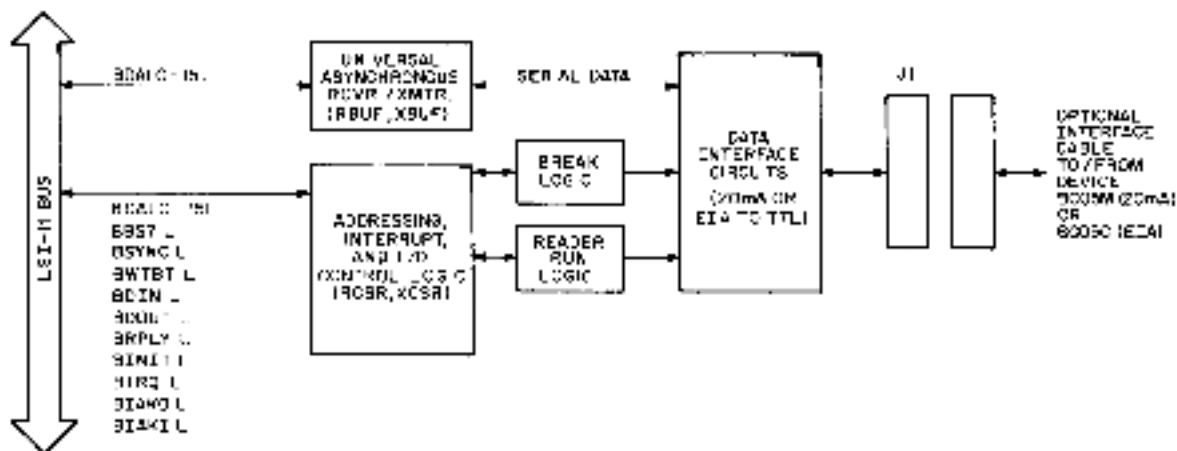

2P-1000

Figure 6-1 DLV11 Serial Line Unit

6.2.2.1 Locations—Thirty jumper locations are provided on the DLV11 module, as shown in Figure 6-2. Jumpers are installed at the factory for use as the console device (Paragraph 6.2.7) and can be altered by the user for his particular system application, as described in the following paragraphs.

6.2.2.2 Addressing — Jumpers involved with addressing include A3 through A12. Only address bits 03 through 12 are programmed by the jumpers for correct DLV11 addressing, producing the 16-bit address word shown in Figure 6-3. The appropriate jumpers are removed to produce logical 1 bits; jumpers installed will produce logical 0 bits.

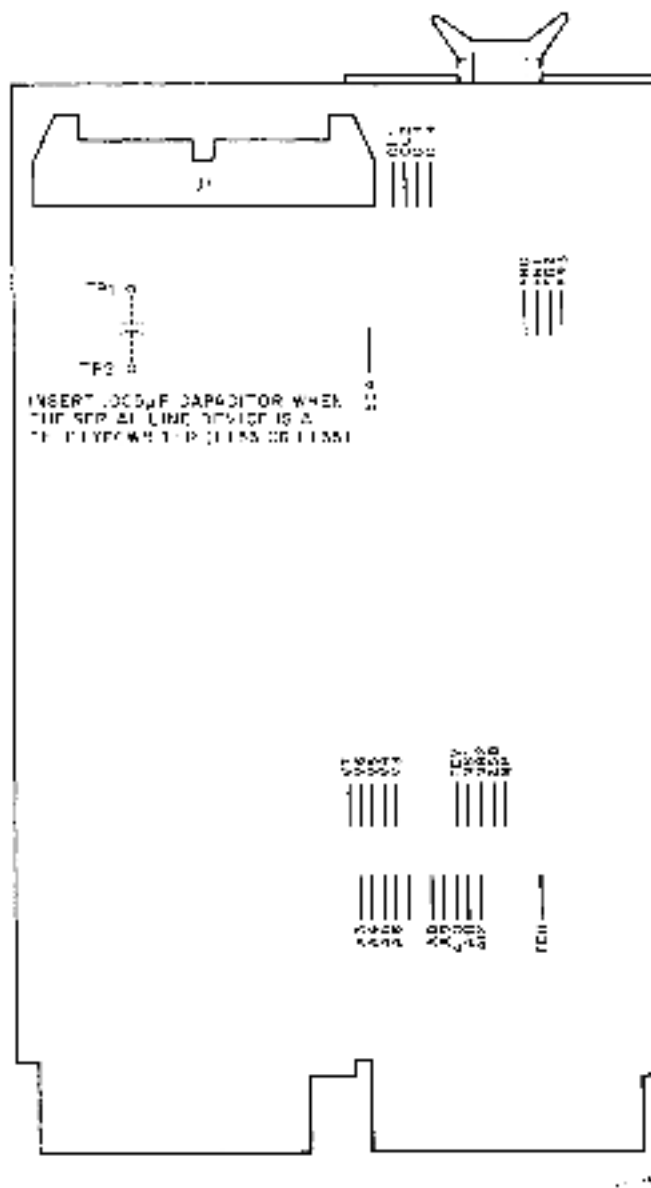

Figure 6-2 DLV11 Jumper Locations

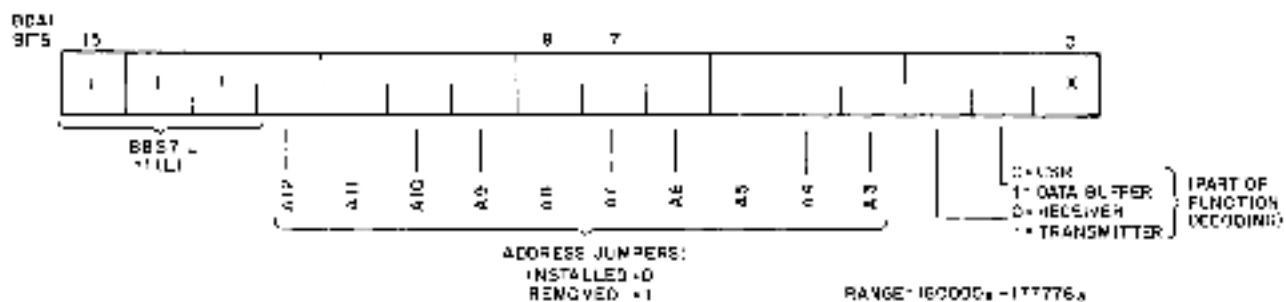

Figure 6-3 DLV11 Addresses

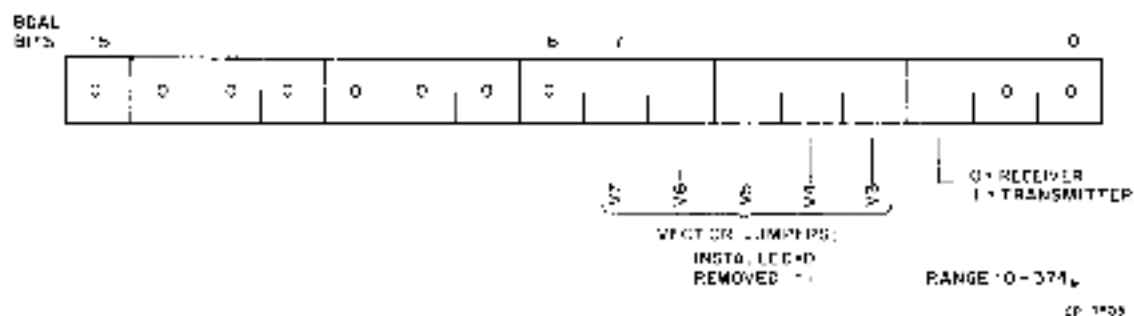

Figure 6-4 DLV11 Interrupt Vectors

6.2.2.3 Vectors — Jumpers involved with vector addressing include V3 through V7. Only vector bits 03 through 07 are programmed by the jumpers for correct DLV11 vector addressing, producing the 16-bit address shown in Figure 6-4. The appropriate jumpers are removed to produce logical 1 bits; jumpers installed will produce logical 0 bits.

6.2.2.4 UAR/T Operation — UAR/T operation is programmed via jumpers NP, 2SB, NB1, NB2, and PEV as shown below.

Number of Data Bits	NB1	NB2
5	Installed	Installed
6	Removed	Installed
7	Installed	Removed
8	Removed	Removed

Number of Stop Bits Transmitted
 2SB installed = One stop bit
 2SB removed = Two stop bits

Parity Transmitted
 NP removed = No parity bit
 NP and PEV installed = Odd parity
 NP installed and PEV removed = Even parity

6.2.2.5 Band Rate Selection — Band rate is programmed via jumpers FR0 through FR3 as shown in Table 6-1.

6.2.2.6 EIA Interface — EIA drivers are enabled when jumper EIA is installed. This jumper applies -12 V to the EIA driver chip. It should be removed during 20 mA current loop operation.

6.2.2.7 20 mA Current Loop Interface — Jumpers CL1 through CL4 are associated with 20 mA current

Table 6-1
Baud Rate Selection

Baud Rate	FR3	FR2	FR1	FR0
50	I	I	R	I
75	I	I	R	R
110	R	R	R	R
134.5	I	R	I	I
150	R	R	R	I
200	I	R	I	R
300	R	R	I	R
600	I	R	R	I
1200	R	I	R	R
1800	R	I	R	I
2400	I	R	R	R
2400	R	R	I	I
4800	R	I	I	R
9600	R	I	I	I
External (via pin B111)	I	I	I	X

NOTE
 I — installed
 R — removed
 X — don't care

loop interface operation. Remove EIA and remove or install jumpers as desired for the functions listed below:

Active Current Loop (Jumpers configuration as shown in Figure 6-5.)

- Transmit = CL3 and CL4 installed
- Receive = CL1 and CL2 installed

Passive Current Loop (Jumpers configured as shown in Figure 6-6.)

- Transmit = CL3 and CL4 removed
- Receive = CL1 and CL2 removed

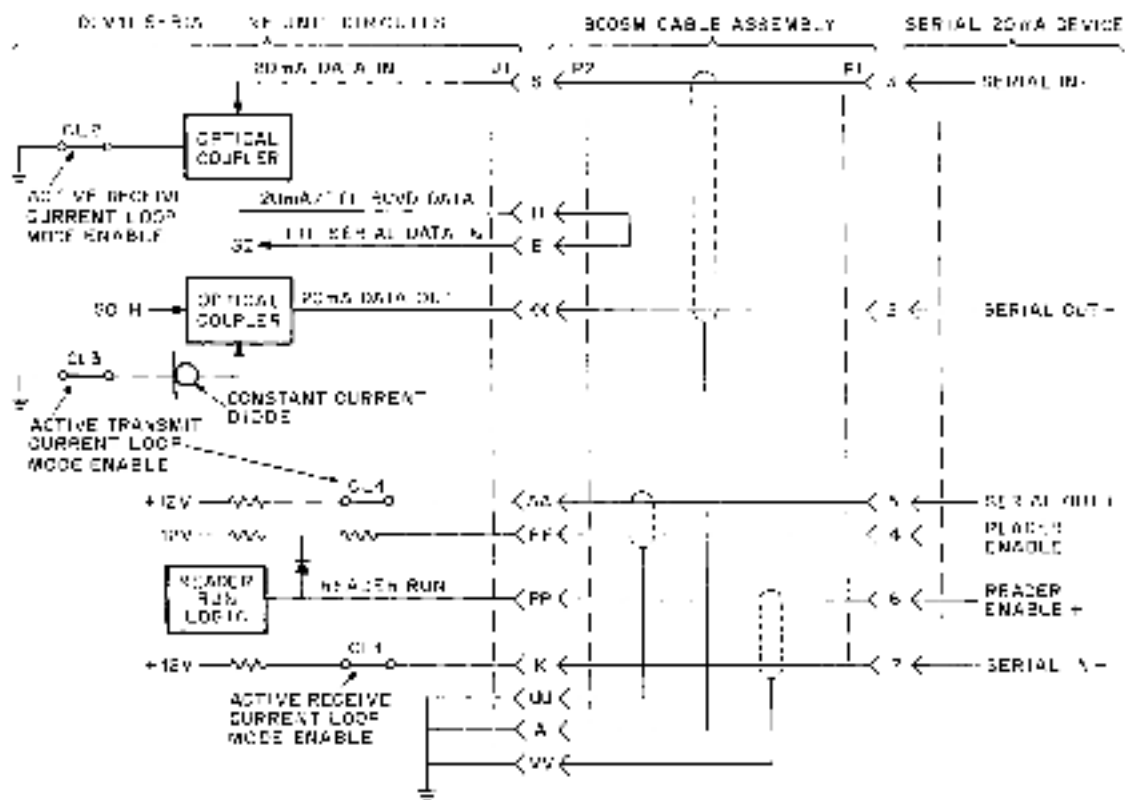

Figure 6-5 Active 20 mA Current Loop Interface

The DLV11 is supplied with jumpers CL1 through CL4 wired for the active transmit, active receive mode (Figure 6-5). When in this mode, serial current limiting to 23 mA is provided by resistors (one each for transmit and receive functions) connected to the -12 V source. Note that when module power is removed, the 20 mA transmit optical coupler closes the serial loop (active or passive mode). When the DLV11 is used in the passive 20 mA mode (Figure 6-6), the serial device must produce the 20 mA current. Current limiting must be provided for transmit and receive currents in the serial device.

6.2.2.8 Framing Error Halt A framing error halt allows entry to console microcode directly from the console device by pressing the BREAK key, producing a framing error. A framing error occurs when the received character has no valid stop bit. This error condition is detected by the UAR². F10 is factory-installed, causing the assertion of BHALT1 when the framing error is detected. The processor then executes console microcode.

6.2.3 Installation

Prior to installing the DLV11 on the backplane, first establish the desired priority level (Chapter 3) to

determine the backplane slot in which the module will be installed. Then, check that jumpers are removed or installed as described for your application (Paragraph 6.2.2). Connection to the peripheral device is via an optional data interface cable. Cables are listed below.

Application	Cable Type*
EIA Interface	BC05C-X Modem Cable
20 mA Current Loop	BC05M-X Cable Assembly

6.2.4 Interfacing with 20 mA Current Loop Devices

When interfacing with 20 mA current loop devices, the BC05M cable assembly provides the correct connections to the 40-pin connector on the DLV11. The peripheral device end of the cable is terminated with a Mate-N-Lok connector that is pin-compatible with the following peripheral options:

- LA36 DECwriter
- LT33 Teletypewriter
- LT35 Teletypewriter

*The -X in the cable number denotes length in feet, as follows: -4, -6, -10, -20, -25. For example, a 10 ft EIA interface cable would be ordered as BC05C-10.

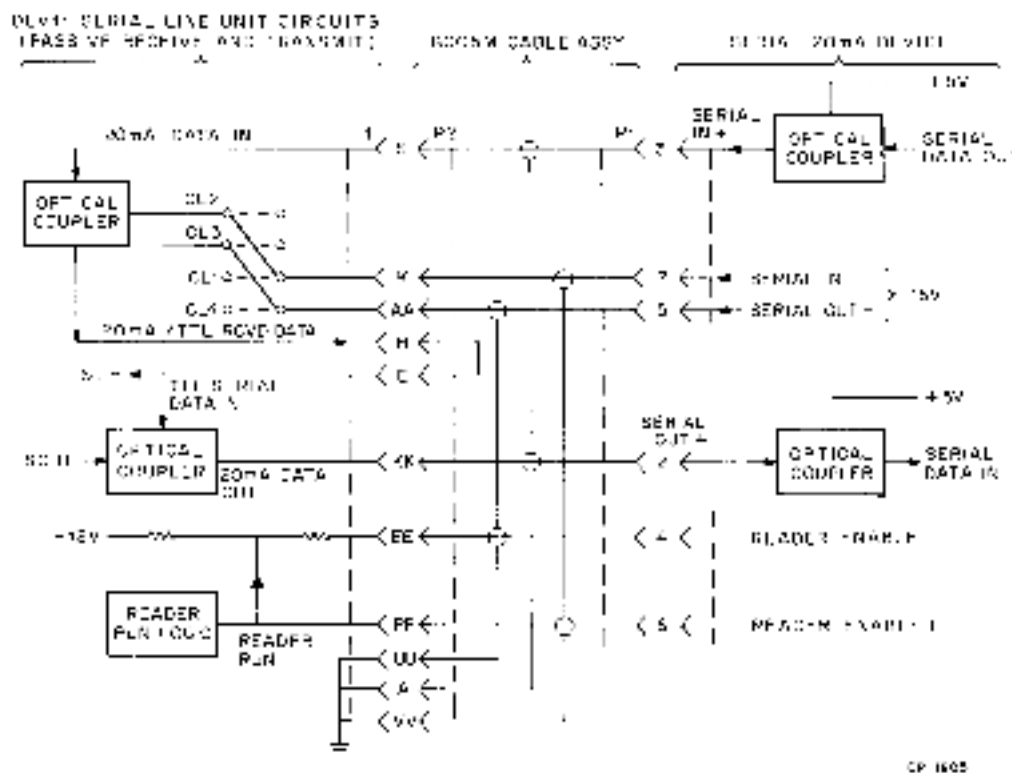

Figure 6-6 Passive 20 mA Loop Jumper Configuration

- VT05B Alphanumeric Terminal
- VT50 DiCscope
- RT02 Alphanumeric Terminals
- DT01-A Acoustic Telephone Coupler

The complete interface circuit provided by the RC05M cable and the associated DLV11 jumpers is shown in Figure 6-5.

NOTE

When the DLV11 is used with teletypewriter devices, a 0.005 μ F capacitor must be installed between split lugs TP1 and TP2.

After configuring the module jumpers and installing the proper interface, the DLV11 can be installed in the backplane.

6.2.5 Interfacing with FIA-Compatible Devices

When interfacing with FIA devices, the RC05C modem cable provides the correct connection to the 40-pin connector on the DLV11. The peripheral device end of the cable is terminated with a Cinch DB25P connector that is pin-compatible with Bell 103, 113 modems. Connector pinning and signal levels conform to FIA Specification RS232C. The complete FIA interface circuit is shown in Figure 6-7.

6.2.6 Programming

6.2.6.1 Addressing - Addresses for the DLV11 can range from 160000 through 17777X₈. The least significant three bits (only bits 01 and 02 are used; bit 0 is ignored) address the desired register in the DLV11, as follows:

Address	Addressed Register
1XXXX0	RCSR (Receiver control/status)
1XXXX2	RBUP (Receiver data buffer)
1XXXX4	XCSR (Transmit control/status)
1XXXX6	XBUF (Transmit data buffer)

Address bits 03 through 12 are jumper-selected as directed in Paragraph 6.2.2.2.

Since each DLV11 module has four registers, each requires four addresses. Addresses 177560—177566 are reserved for the DLV11 used with the console peripheral device. Additional DLV11 modules should be assigned addresses from 175610 through 176176, allowing up to 30 additional DLV11 modules to be addressed.

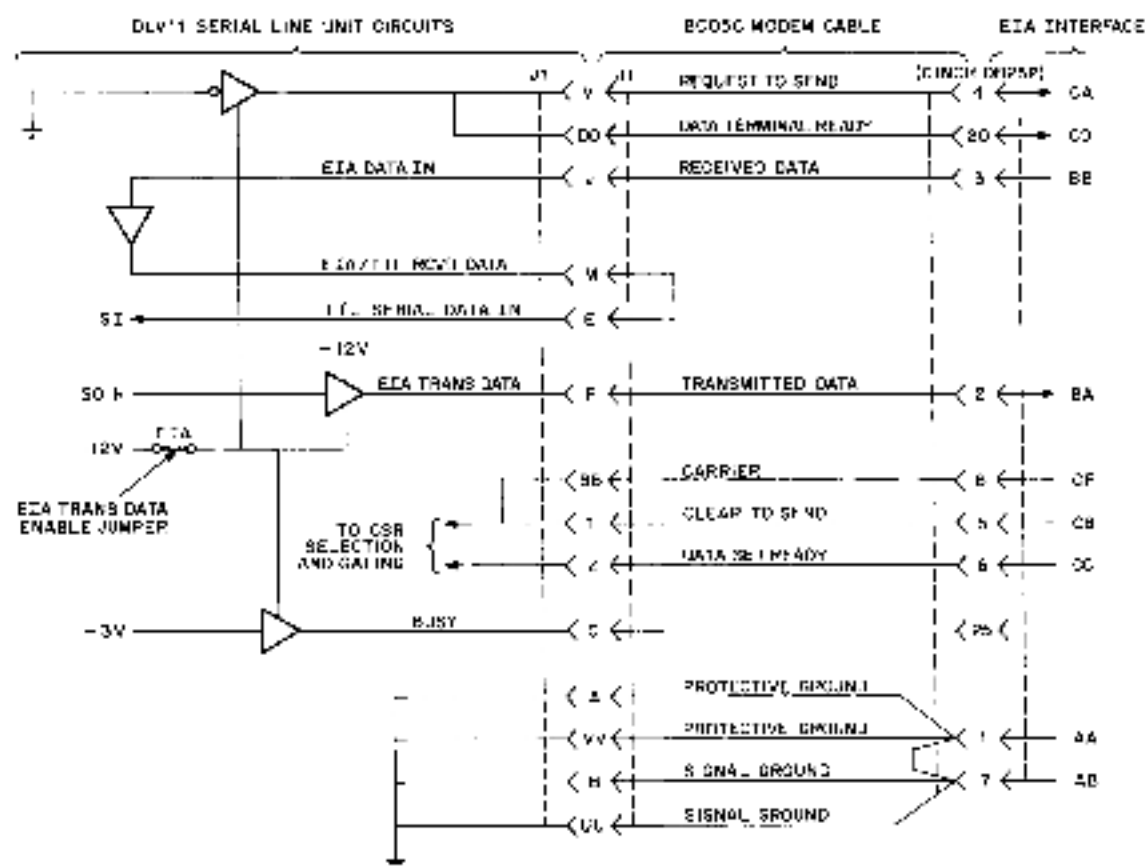

Figure 6-7 EIA Interface

6.2.6.2 Interrupt Vectors Two interrupt vectors are jumper-selected on each DLV11 as described in Paragraph 6.2.2.3:

- 000XX0 Receiver interrupt vector
- 000XX4 Transmitter interrupt vector

Vectors can range from addresses 0 through 37X₁. Vectors 60 and 64 are reserved for the console peripheral device. Additional DLV11 modules should be assigned vectors following any DRV11 modules installed in the system starting at address 300.

6.2.6.3 Word Formats — The four word formats associated with the DLV11 are shown in Figure 6-8 and are described in Table 6-2.

6.2.7 Console Device

The console device is a serial line device, such as the LA36 DECwriter, that uses a DLV11 Serial Line Unit. The following device addresses must be used for the console device:

Register	Address
RCSR	177560
RBUP	177562
XCSR	177564
XBUP	177566

Vector addresses must be assigned as follows.

Interrupt Vector	Address
Console Receiver	000060
Console Transmitter	000064

6.3 DRV11 PARALLEL LINE UNIT

6.3.1 General

The DRV11 Parallel Line Unit is a general-purpose device interface module that connects parallel I/O devices to the LSI-11 bus, as shown in Figure 6-9.

6.3.2 Jumper-Selected Addressing and Vectors

Table 6-2
Word Formats

Word	Bit(s)	Function
RCSR	15	Dataset Status — Set when CARRIER or CLEAR TO SEND and DATA SET READY signals are asserted by an EIA device. Read-only bit.
	14—08	Not used. Read as 0.
	07	Receiver Done — Set when an entire character has been received and is ready for input to the processor. This bit is automatically cleared when RBUF is addressed or when the BDCOK H signal goes false (low). A receiver interrupt is enabled by the DLV11 when this bit is set and receiver interrupt is enabled (bit 6 is also set). Read-only bit.
	06	Interrupt Enable — Set under program control when it is desired to generate a receiver interrupt request when a character is ready for input to the processor (bit 7 is set). Cleared under program control or by the BINIT signal. Read/write bit.
	05—01	Not used. Read as 0.
	00	Reader Enable — Set by program control to advance the paper tape reader on a teletypewriter device to input a new character. Automatically cleared by the new character's start bit. Write-only bit.
RBUF	15—08	Not used. Read as 0.
	07—00	Contains five to eight data bits in a right-justified format. MSB is the optional parity bit. Read-only bit.
XCSR	15—08	Not used. Read as 0.
	07	Transmit Ready — Set when XBUF is empty and can accept another character for transmission. It is also set during the power-up sequence by the BDCOK H signal. Automatically cleared when XBUF is loaded. When transmitter interrupt is enabled (bit 6 also set), an interrupt request is asserted by the DLV11 when this bit is set. Read-only bit.
	06	Interrupt Enable — Set under program control when it is desired to generate a transmitter interrupt request when the DLV11 is ready to accept a character for transmission. Reset under program control or by the BINIT signal. Read/write bit.
	05—01	Not used. Read as 0.
	00	Break — Set or reset under program control. When set, a continuous space level is transmitted. BINIT resets this bit. Read/write bit.
XBUF	15—08	Not used.
	07—00	Contains five to eight right-justified data bits. Loaded under program control for serial transmission to a device. Write only.

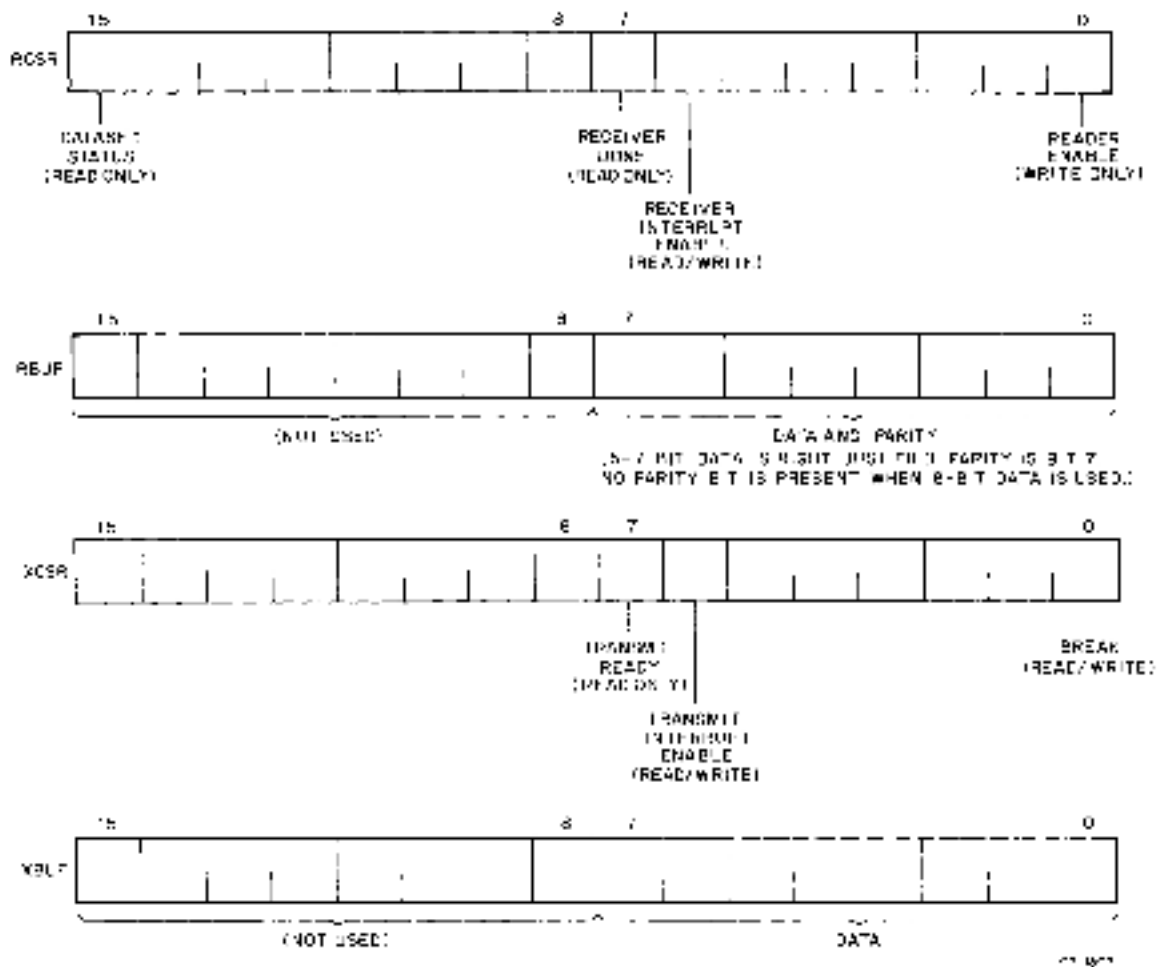

Figure 6-8 DRV11 Word Formats

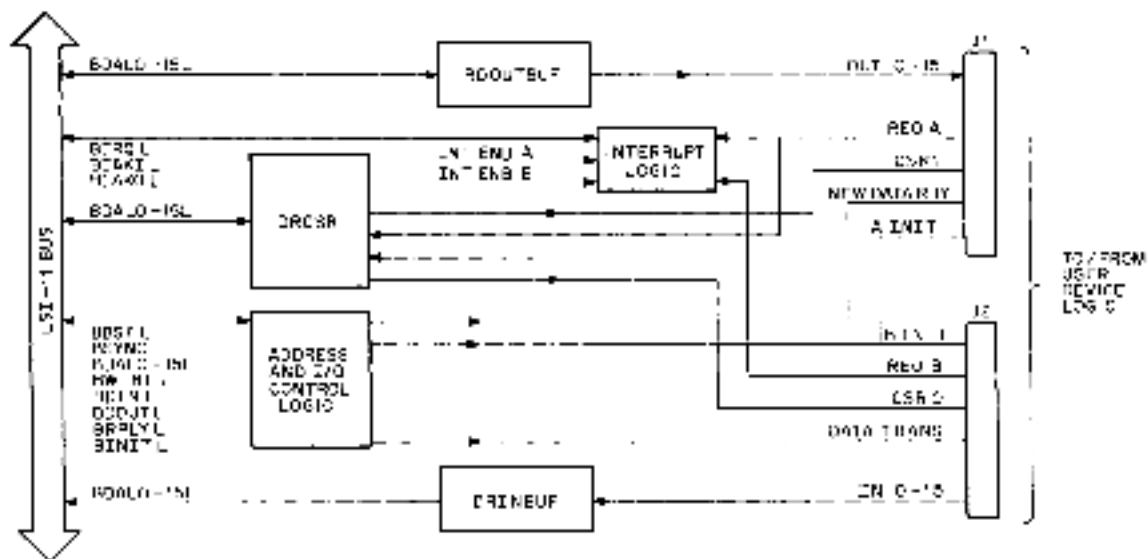

Figure 6-9 DRV11 Parallel Line Unit

6.3.2.1 Locations — Jumpers for device address and vector selection are provided on the DRV11 as shown in Figure 6-10. Jumpers are installed at the factory for address 167770 (DRC SR) and vectors 300 (interrupt A) and 304 (interrupt B). These can be cut or removed by the user to program the module for his system application, as described in the following paragraphs.

6.3.2.2 Addressing — Jumpers involved with addressing include A3 through A12. Only address bits 03 through 12 are programmed by jumpers for DRV11 addressing, producing the 16-bit address word shown in Figure 6-11. The appropriate jumpers are removed to produce logical 1 bits; jumpers installed will produce logical 0 bits.

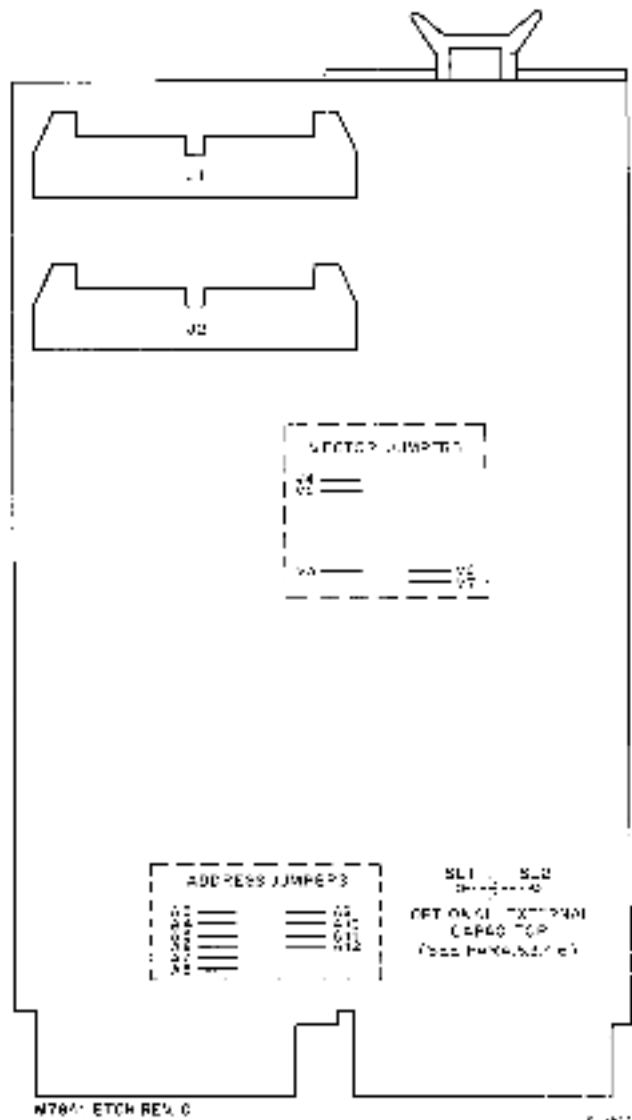

Figure 6-10 DRV11 Jumper Locations

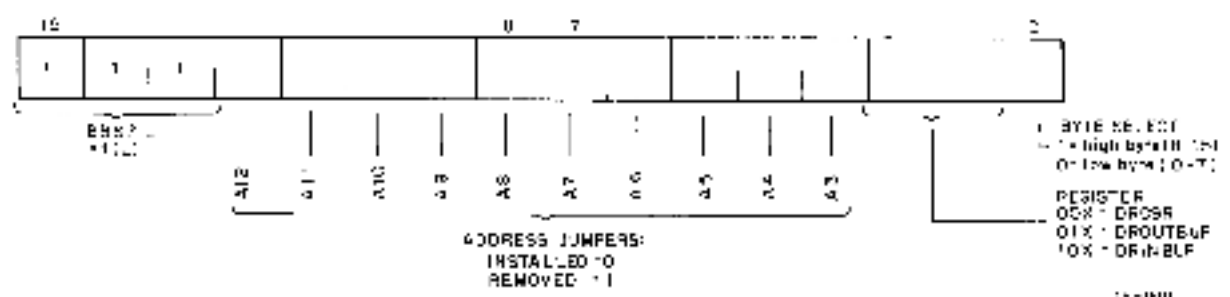

Figure 6-11 DRV11 Device Address

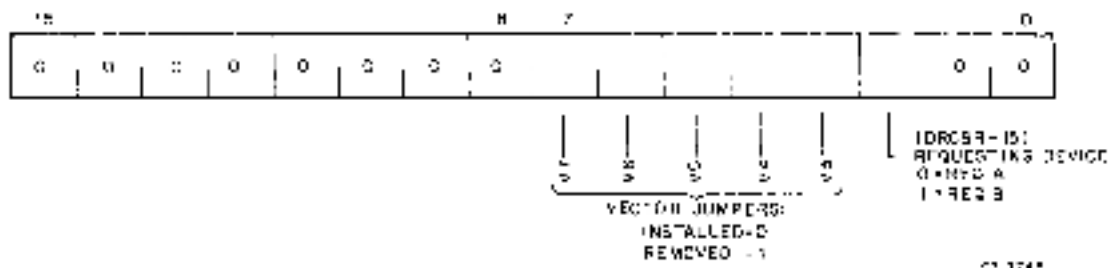

Figure 6-12 DRV11 Vector Address

6.3.2.3 Vectors -- Jumpers involved with vector addressing include V3 through V7. Only vector bits 03 through 07 are programmed by the jumpers for DRV11 vector addressing, producing the 16-bit word shown in Figure 6-12. The appropriate jumpers are removed to produce logical 1 bits; jumpers installed will produce logical 0 bits.

6.3.3 Installation

Prior to installing the DRV11 on the backplane, first establish the desired priority level (Chapter 3) for the backplane slot installation. Check that proper device address and vector jumpers are installed, as directed in Paragraph 6.3.2. The DRV11 can then be installed on the backplane. Connection to the user's device is via optional cables.

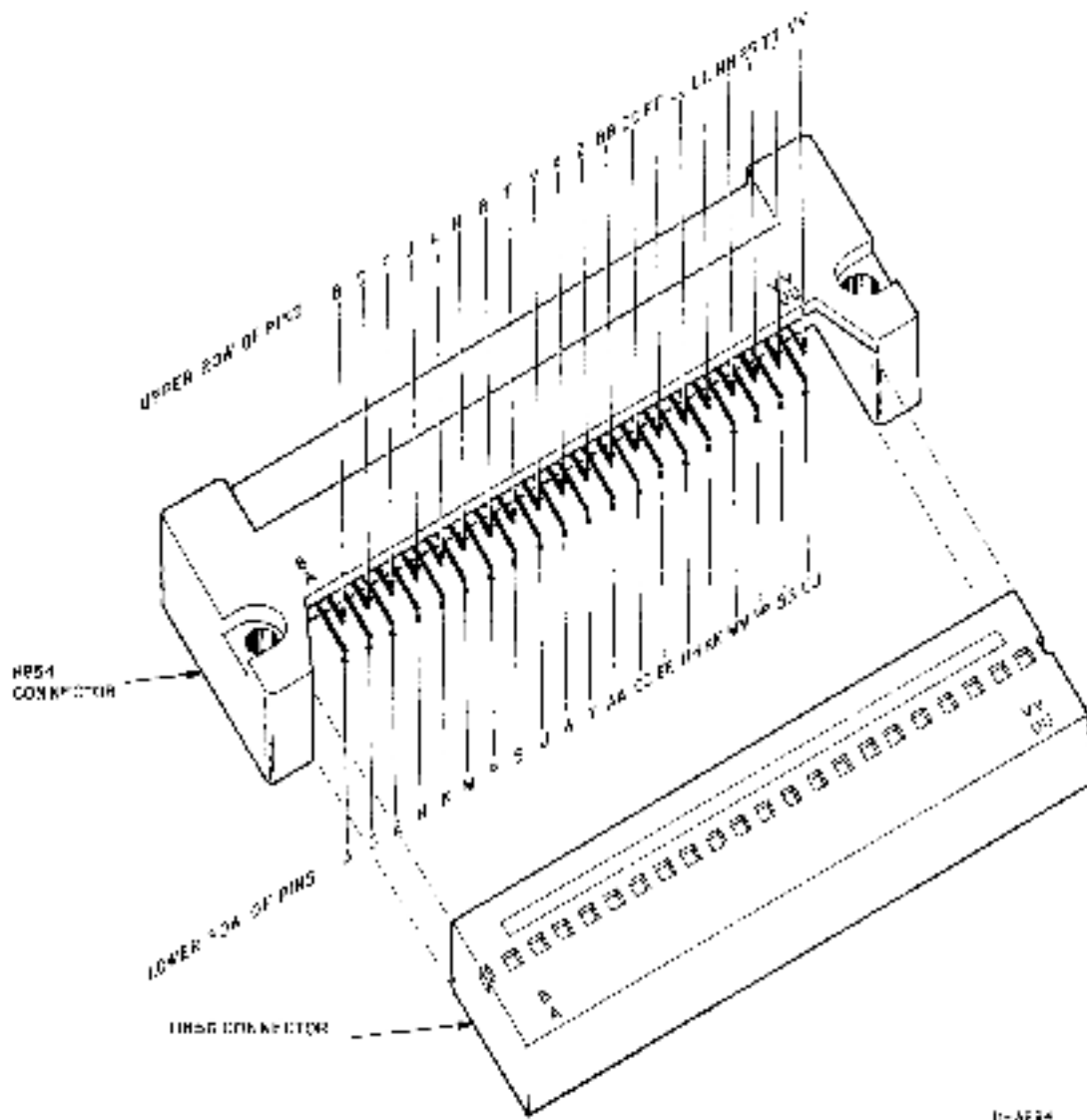

Figure 6-13 J1 or J2 Connector Pin Locations

6.3.4 Interfacing to the User's Device

6.3.4.1 General — Interfacing the DRV11 to the user's device is via the two board-mounted H854 40-pin male connectors. Pins are located as shown in Figure 6-13. Signal pin assignments for input interface J2 (connector No. 2) and output interface J1 (connector No. 1) are listed in Table 6-3. Optional cables and connectors for use with the DRV11 include:

BC05R-X* — Maintenance cable, 40-conductor flat with H856 connectors on each end. Available in lengths of 1, 6, 10, 20, and 25 feet.

BC11K-25 — Signal cable, 20 twisted pair with H856 connector on one end; remaining end is terminated by the user.

H856 — Socket, 40-pin female, for user-fabricated cables.

When using the BC11K-25 cable, connect the free end of the cable using the wiring data contained in Table 6-4. Refer to the *Hardware/Accessories Catalog* for additional optional interface accessories.

6.3.4.2 Output Data Interface — The output interface is the 16-bit buffer (DROUTBUF). It can be either loaded or read under program control. When loaded by a DATO or DATOB bus cycle, the NEW DATA READY H 750 ns pulse is generated to inform the user's device of the data transfer. The trailing edge of this positive-going pulse should be used to strobe the data into the user's device in order to allow data to settle on the interface cable. The system initialize signal (BINIT 1.) will clear DROUTBUF.

All output signals are TTL levels capable of driving eight unit loads except for the following:

NEW DATA READY = 10 unit loads
 DATA TRANSMITTED = 30 unit loads
 INIT (Initialize)* = 10 unit loads per conductor

*The X in the cable order denotes length in feet, as follows: -1, -6, -10, -20, -25. For example, a 10-ft maintenance cable would be ordered as BC05R-10.

*Common signal on both connectors.

Table 6-3
DRV11 Input and Output Signal Pins

Inputs			Outputs		
Signal	Connector	Pin	Signal	Connector	Pin
IN00	J2	TT	OUT00	J1	C
IN01	J2	LL	OUT01	J1	K
IN02	J2	H, F	OUT02	J1	NN
IN03	J2	BB	OUT03	J1	U
IN04	J2	KK	OUT04	J1	L
IN05	J2	HH	OUT05	J1	N
IN06	J2	EE	OUT06	J1	R
IN07	J2	CC	OUT07	J2	T
IN08	J2	Z	OUT08	J1	W
IN09	J2	Y	OUT09	J1	X
IN10	J2	W	OUT10	J1	Z
IN11	J2	V	OUT11	J1	AA
IN12	J2	U	OUT12	J1	BB
IN13	J2	P	OUT13	J1	FF
IN14	J2	N	OUT14	J1	HH
IN15	J2	M	OUT15	J1	JJ
REQ A	J1	LL	NEW DATA RDY*	J1	VV
REQ B	J2	S	DATA TRANS*	J2	C
			CSR0	J2	K
			CSR1	J1	DD
			INIT	J1	P
			INIT	J2	RR, NN

*Pulse signals, approximately 300-ns wide. Width can be changed by user.

Table 6-4
BC11K Signal Cable Connections

Twisted Pair	Color	Pin	Connected To J1	Connected To J2
Black/white-orange	black wh-org	A	OPEN	OPEN
		B	OPEN	OPEN
Black/white-yellow	black wh-yel	C	OUT00	DATA TRANS.
		D	OPEN	OPEN
Black/white-grey	black wh-gry	E	OPEN	IN02
		F	OPEN	OPEN
Black/white-red	black wh-red	H	OPEN	IN02
		J	GND	GND
Black/white-green	black wh-grn	K	OUT01	CSR0
		L	OUT04	GND
Brown/green	brown green	M	GND	IN15
		P	INIT	IN13
Brown/red	brown red	N	OUT05	IN14
		R	OUT06	GND
Black/white-blue	black wh-blu	S	GND	REQ B
		T	OUT07	GND
Black/orange	black orange	U	OUT03	IN12
		V	GND	IN11
Black/white-violet	black wh-vio	W	OUT08	IN10
		X	OUT09	GND
Black/red	black red	Y	GND	IN09
		Z	OUT10	IN08
Brown/yellow	brown yellow	AA	OUT11	GND
		BB	OUT12	IN03
Black/blue	black blue	CC	GND	IN07
		DD	CSR1	GND
Brown/orange	brown orange	EE	GND	IN06
		FF	OUT13	OPEN
Brown/blue	brown blue	HH	OUT14	IN05
		JJ	OUT15	GND
Black/yellow	black yellow	KK	GND	IN04
		LL	REQ A	IN01
Brown/violet	brown violet	MM	GND	GND
		NN	OUT02	INIT
Black/violet	black violet	PP	GND	GND
		RR	OUT02	INIT
Black/green	black green	SS	GND	GND
		TT	OPEN	IN00
Pink/white-red	pink wh-red	UU	GND	GND
		VV	NEW DATA RDY	OPEN

6.3.4.3 Input Data Interface — The input interface is the 16-bit DRINBUF read-only register, comprising gated bus drivers that transfer data from the user's device onto the LSI-11 bus under program control. DRINBUF is not capable of storing data; hence, the user must keep input data on the IN lines until read by the LSI-11 microprocessor. When read, the DRV11 generates a positive-going 750 ns DATA TRANSMITTED H pulse which informs the user's device that the data has been accepted. The trailing edge of the pulse indicates that the input transfer has been completed.

All input signals are one standard TTL unit load; inputs are protected by diode clamps to ground and +5 V.

6.3.4.4 Request Flags — Two signal lines (REQ A H and REQ B H) can be asserted by the user's device as flags in the DRCSR word. REQ B is available via Connector No. 2, and it can be read in DRCSR bit 15. REQ A is available via Connector No. 1, and it can be read in DRCSR bit 7. Two DRCSR interrupt enable bits, INT ENB A (bit 6) and INT ENB B (bit 5), allow automatic generation of an interrupt request when their respective REQ A or REQ B signals are asserted. Interrupt enable bits can be set or reset under program control.

In a typical application, REQ A and REQ B are generated by Request flip-flops in the user's device. The user's Request flip-flop should be set when servicing is required and cleared by NEW DATA READY or DATA TRANSMITTED when the appropriate data transaction has been completed.

6.3.4.5 Initialization — The BINIT L processor-generated initialize signal is applied to DRV11 circuits for interface logic initialization. It is also available to the user's circuits via connectors J1 and J2 as follows:

Connector/Pin	Signal
J1/P	AINIT H
J2/RR	BINIT H
J2/NN	BINIT H

An active BINIT L signal will clear DROUTBUF data; DRCSR bits 6, 5, 1, 0; bits 16 and 7 (when the maintenance cable is connected); and Interrupt Request and Interrupt Acknowledge flip-flops.

6.3.4.6 NEW DATA READY and DATA TRANSMITTED Pulse Width Modification — An optional capacitor can be added by the user to the DRV11 module to extend the pulse width of both the NEW

DATA READY and DATA TRANSMITTED pulse widths. The module without external capacitance (as shipped) will produce 750 ns pulses. The capacitor can be added in the location shown in Figure 6-10 to produce the approximate pulse widths listed below.

Optional External Capacitance (μ F)	Approximate Pulse Width (ns)
None	750
0.0047	1150
0.01	1750
0.02	2650
0.03	3850

6.3.4.7 BUFFER Maintenance Cable — When using the optional BUFFER maintenance cable, the connections listed in Table 6-5 are provided. Cable connectors P1 and P2 are connected to DRV11 connectors J1 and J2, respectively. Note that CSR0 (J2-K), which can be set or reset under program control, is routed to the REQ A input (J1-LL); similarly, CSR1 (J1-DI) is routed to REQ B (J2-S). Hence, a maintenance program can output data to DROUTBUF and read the same data via the cable and DRINBUF. DRCSR bits 0 (CSR0) and 1 (CSR1) can be used to simulate REQ A and REQ B signals, respectively. If the appropriate INT ENB bit (DRCSR bits 5 or 6) is set, the simulated signal will generate an interrupt request.

6.3.5 Programming

6.3.5.1 Addressing — Address for the DRV11 can range from 160000 through 17777X₆. The least significant three bits address the desired DRV11 register as follows:

Address	Device Register
1XXXX0	DRCSR
1XXXX2	DROUTBUF
1XXXX4	DRINBUF

Addresses 177560—177566 are reserved for the console device and should not be used for DRV11 addressing. The following address assignments are normally used:

First DRV11

DRCSR = 167770
DROUTBUF = 167772
DRINBUF = 167774

Second DRV11

167760 to 167764

Third DRV11

167750 to 167754

Table 6-5
BC08R Maintenance Cable Signal Connections

J2		J1	
Pin	Name	Name	Pin
VV	OPEN	OPEN	A
UU	GND	OPEN	B
TT	IN00	OUT00	C
SS	GND	OPEN	D
RR	IN11	OPEN	E
PP	GND	OPEN	F
NN	IN1H	OPEN	H
MM	GND	GND	J
LL	IN01	OUT01	K
KK	IN04	OUT04	L
JJ	GND	GND	M
HH	IN05	OUT05	N
FF	OPEN	IN1H	P
EE	IN06	OUT06	R
DD	GND	GND	S
CC	IN07	OUT07	T
BB	IN03	OUT03	U
AA	GND	GND	V
Z	IN08	OUT08	W
Y	IN09	OUT09	X
X	GND	GND	Y
W	IN10	OUT10	Z
V	IN11	OUT11	AA
U	IN12	OUT12	BB
T	GND	GND	CC
S	REQ B	CSR1	DD
R	GND	GND	EE
P	IN13	OUT13	FF

Table 6-5 (Continued)
BC08R Maintenance Cable Signal Connections

J2		J1	
Pin	Name	Name	Pin
N	IN14	OUT14	HH
M	IN15	OUT15	JJ
L	GND	GND	KK
K	CSR0	REQ A	LL
J	GND	GND	MM
H	IN02	OUT02	NN
F	OPEN	GND	PP
E	IN02	OUT02	RR
D	OPEN	GND	SS
C	DATA TRANS	OPEN	TT
B	OPEN	GND	UU
A	OPEN	NEW DATA RDY	VV

6.3.5.2 Interrupt Vectors -- Two interrupt vectors are jumper-selected in the range of 0 through 37X₈. The least significant three bits identify the interrupting function.

000XX0	Interrupt A
000XX4	Interrupt B

Vectors 00 and 04 are reserved for the console device and should not be used for DRV11 vectors.

6.3.5.3 Word Formats -- The three word formats associated with the DRV11 are shown in Figure 6-14 and are described in Table 6-6.

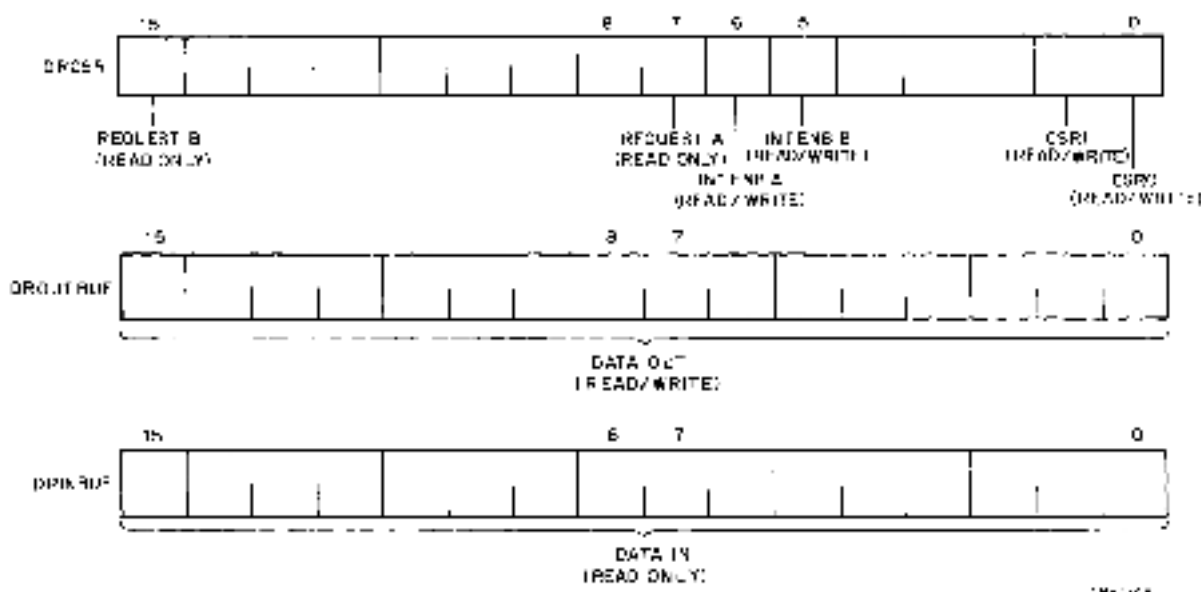

Figure 6-14 DRV11 Word Formats

Table 6-6
Word Formats

Word	Bit(s)	Function
CRCSR	15	<p>REQUEST B — This bit is under control of the user's device and may be used to initiate an interrupt sequence or to generate a flag that may be tested by the program.</p> <p>When used as an interrupt request, it is asserted by the external device and initiates an interrupt provided the INT ENB B bit (bit 05) is also set. When used as a flag, this bit can be read by the program to monitor external device status.</p> <p>When the maintenance cable is used, the state of this bit is dependent on the state of CSR1 (bit 01). This permits checking interface operation by loading a 0 or 1 into CSR1 and then verifying that REQUEST B is the same value.</p> <p>Read-only bit. Cleared by INIT when in maintenance mode.</p>
	14—08	Not used. Read as 0.
	07	<p>REQUEST A — Performs the same function as REQUEST B (bit 15) except that an interrupt is generated only if INT ENB A (bit 06) is also set.</p> <p>When the maintenance cable is used, the state of REQUEST A is identical to that of CSR0 (bit 00).</p> <p>Read-only bit. Cleared by INIT when in maintenance mode.</p>
	06	<p>INT ENB A — Interrupt enable bit. When set, allows an interrupt request to be generated, provided REQUEST A (bit 07) becomes set.</p> <p>Can be loaded or read by the program (read/write bit). Cleared by INIT.</p>
	05	<p>INT ENB B — Interrupt enable bit. When set, allows an interrupt sequence to be initiated, provided REQUEST B (bit 15) becomes set.</p>
	04—02	<p>Not used. Read as 0.</p> <p>Can be loaded or read by the program (read/write bit). Cleared by INIT.</p>
	01	<p>CSR1 — This bit can be loaded or read (under program control) and can be used for a user-defined command to the device (appears only on Connector No. 1).</p> <p>When the maintenance cable is used, setting or clearing this bit causes an identical state in bit 15 (REQUEST B). This permits checking operation of bit 15 which cannot be loaded by the program.</p> <p>Can be loaded or read by the program (read/write bit). Cleared by INIT.</p>
	00	<p>CSR0 — This bit can be loaded or read (under program control) and can be used for a user-defined command to the device (appears only on Connector No. 1).</p> <p>When the maintenance cable is used, setting or clearing this bit causes an identical state in bit 07 (REQUEST A). This permits checking operation of bit 07 which cannot be loaded by the program.</p> <p>Can be loaded or read by the program (read/write bit). Cleared by INIT.</p>

Table 6-6 (Continued)
Word Formats

Word	Bit(s)	Function
DRCSR	00	<p>CSR0 — Performs the same functions as CSR1 (bit 01) but appears only on Connector No. 2.</p> <p>When the maintenance cable is used, the state of this bit controls the state of bit 07 (REQUEST A).</p> <p>Read/write bit. Cleared by INIT.</p>
DROUTBUF	15—00	<p>Output Data Buffer — Contains a full 16-bit word or one or two 8-bit bytes: High Byte = 15—8; Low Byte = 7—0.</p> <p>Loading is accomplished under a program-controlled DATO or DATOB bus cycle. It can be read under a program-controlled DATI cycle.</p>
DRINBUF	15—00	<p>Input Data Buffer — Contains a full 16-bit word or one or two 8-bit bytes. The entire 16-bit word is read under a program-controlled DATI bus cycle.</p>

CHAPTER 7

USING MSV11-A AND MSV11-B READ/WRITE MEMORY MODULES

7.1 GENERAL

MSV11-B(4K) read/write memory modules provide temporary storage of user programs and data in an inexpensive, compact, low-power memory subsystem. The user can select the 4K address space (bank) in which the module is addressed by installing or removing jumpers.

The module can be accessed by the LSI-11 microcomputer or any DMA device that becomes bus master. Interface with the LSI-11 bus is shown in Figure 7-1.

7.2 MSV11-B JUMPERS

7.2.1 Addressing

MSV11-B address jumpers are located as shown in Figure 7-2. The module is supplied with all address jumpers installed. Figure 7-3 illustrates a 16-bit address and how jumpers are assigned for the MSV11-B module.

7.2.2 Reply to Refresh

Only one dynamic memory module in a system is required to reply to the refresh bus transactions initiated by the processor. The module selected to reply should be the module with the slowest access time. Jumper W4 enables or inhibits the MSV11-B reply as follows:

W4 installed: MSV11-B will not assert BRPLY in response to refresh bus signals.

W4 removed: MSV11-B will reply to refresh bus BSYNC/BDM transactions by asserting BRPLY L.

7.3 MSV11-B BUS RESTRICTION

The MSV11-B module requires a refresh sequence once every 1.6 ms. This is performed automatically by the KD11-F or KD11-J LSI-11 microcomputer.

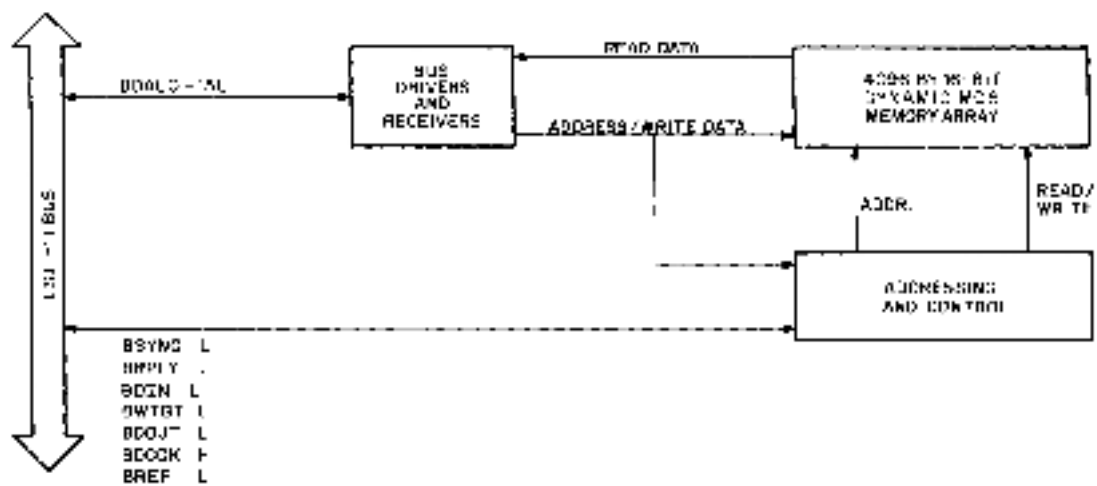

Figure 7-1 MSV11-B 4K by 16-Bit Read/Write Memory

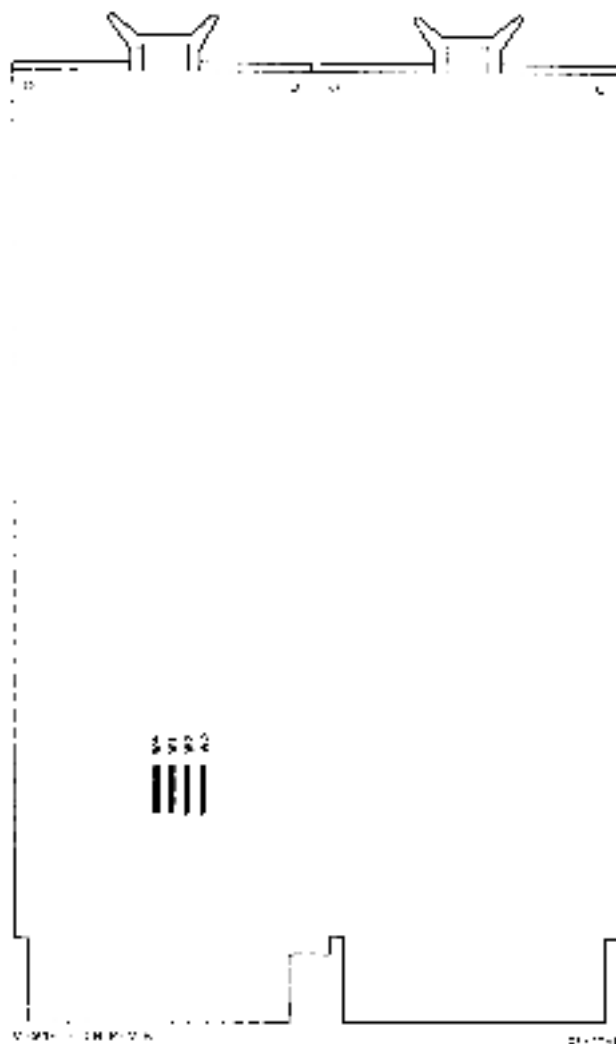
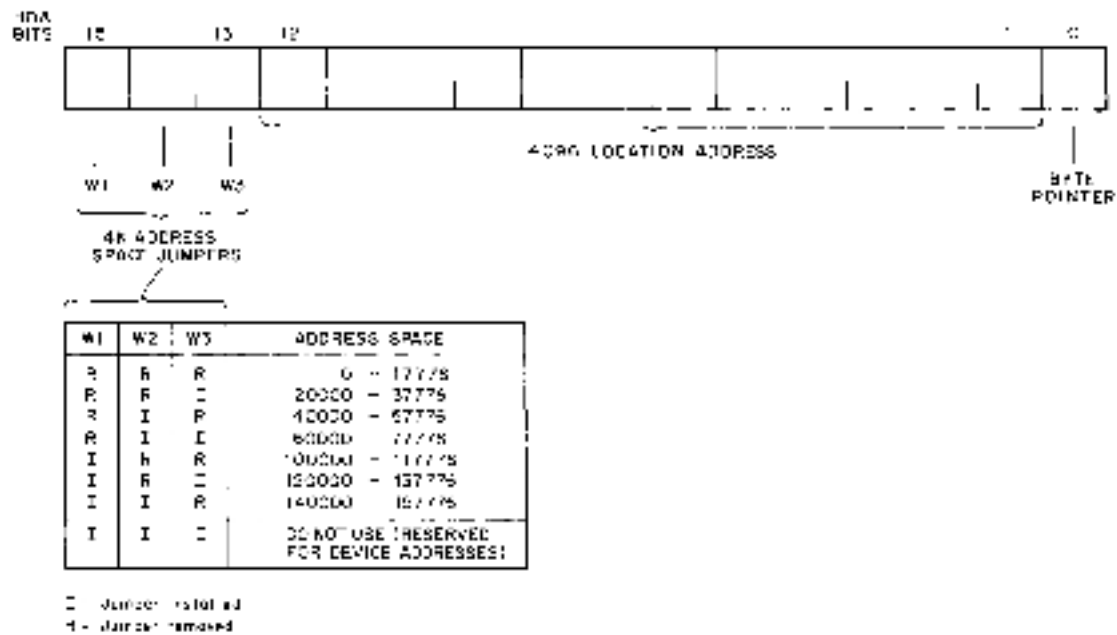

Figure 7-2 MSV11-B Jumper Locations



MSV-11-B

Figure 7-3 MSV11-B Address Format/Jumpers

CHAPTER 8

USING MMV11-A CORE MEMORY

8.1 GENERAL

The MMV11-A core memory option comprises two modules (G653 and 11223) which are mated by connector pins in a single 6.5 by 10 by 0.9 inch assembly. It requires two device locations (electrical positions) on the backplane when installed in slots A4-D4 (Figure 11-1); otherwise, because of its total thickness (0.9 inch), the MMV11-A requires four physical device locations when installed in any other backplane slot.

8.2 SWITCH-SELECTED ADDRESSING

8.2.1 General

The only preparation required for the MMV11-A be-

fore it is installed in the backplane is to select its bank address. This is accomplished by opening or closing switches in appropriate address bit locations to produce the desired bank address decoding.

(Refer to Paragraph 11.3.3 for installation considerations.) Memory capacity is 4096 16-bit words. Address decoding jumpers allow the user to select the 4K bank address to which the MMV11-A will respond.

The MMV11-A is fully LSI-11 bus-compatible and can be accessed by the LSI-11 microcomputer or any DMA device that becomes bus master. It interfaces with the bus as shown in Figure 8-1.

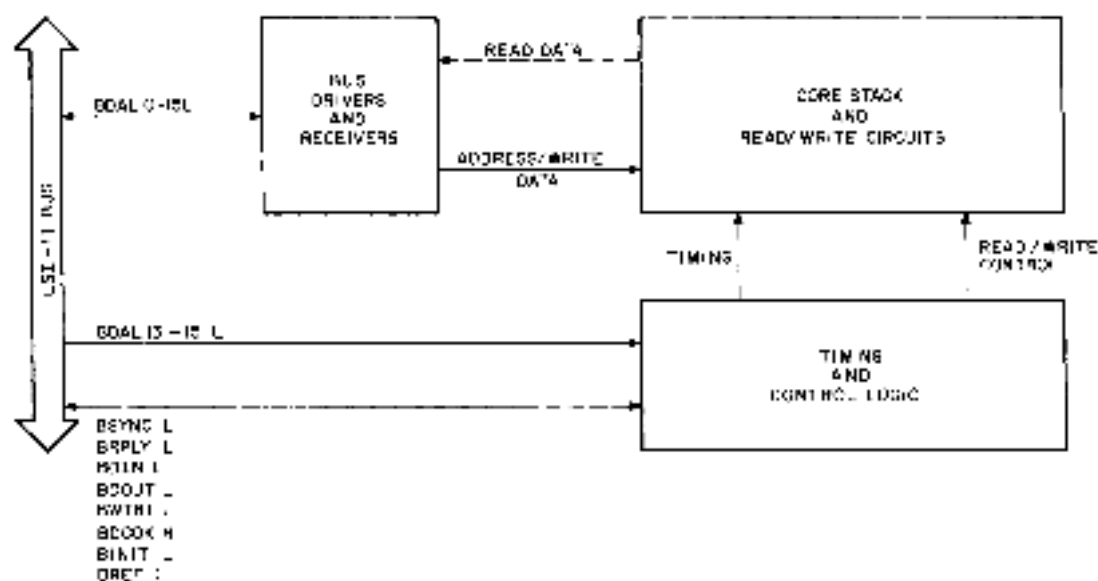

DP-1124

Figure 8-1 MMV11-A 4K by 16-Bit Core Memory

MMV11-A bank address switches are used as shown in Figure 8-3. The figure illustrates a 16-bit address and how switches are assigned to each address bit. Open or close switches to produce the desired bank address as directed in the figure. Switches are located on the G653 module (component side) as shown in Figure 8-2.

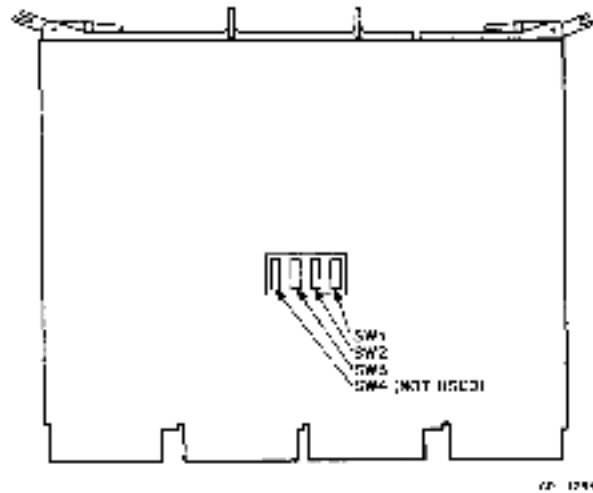

Figure 8-2 Bank Address Switch Locations

8.3 BUS RESTRICTIONS

The BDMG1 L and BLAK1 L bus lines must be jumpered to BDMG0 L and BLAK0 L lines, respectively, under the H223 module when installed between the processor and I/O device interface modules in order to maintain daisy-chain signal continuity.

Pins which must be connected are:

From	To	Signal
AM2	AN2	BLAK1/O L
CM2	CN2	BLAK1/O L
AR2	AS2	BDMG1/O L
CR2	CS2	BDMG1/O L

Bus pins can be identified as shown in Figures 3-2 and 3-3.

Memory refresh is not required for this memory option. If memory refresh is used for other memory options, such as the KD11-F's resident memory and the MSV11-B semiconductor memory, the MMV11-A will not respond to the refresh operation.

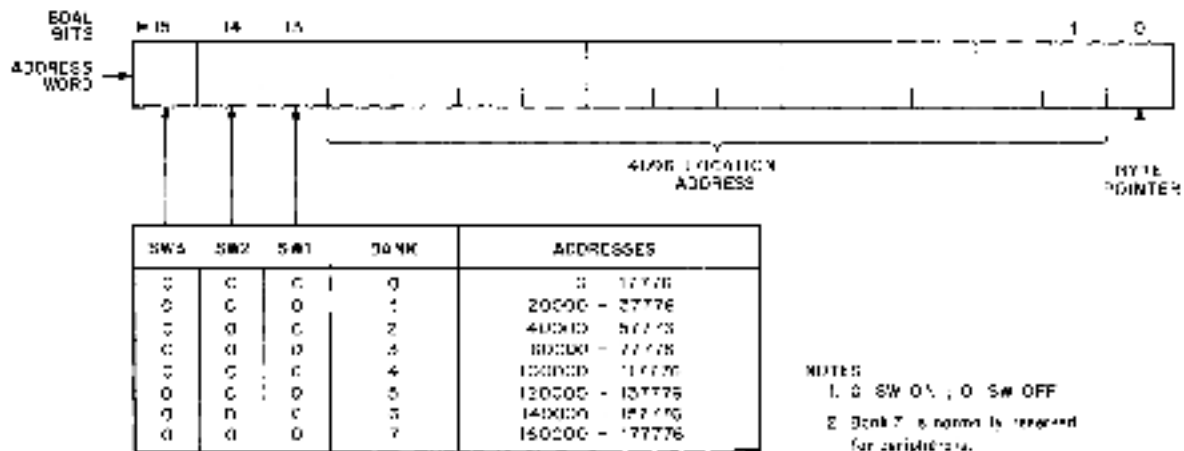

CS 1753

Figure 8-3 MMV11-A Addressing

CHAPTER 9

USING MRV11-A READ-ONLY MEMORY

9.1 GENERAL

The MRV11-A (Figure 9-1) is a read-only memory module which allows the use of user-supplied, preprogrammed, programmable read-only memory (PROM) and masked read-only memory (ROM) chips in a compact, nonvolatile memory subsystem. Depending upon chip types, the module's capacity is either 4096 16-bit words or 2048 16-bit words, using 512 by 4-bit or 256 by 4-bit chips, respectively. Full address decoding is provided on the module. The user can select the 4K address bank in which the module resides by installing

(or removing) jumpers on the module. Similarly, when using 256 by 4-bit chips, the user can jumper-select the upper or lower 2K segment within the selected 4K address bank. Note that 512 by 4-bit and 256 by 4-bit chips cannot be mixed on a MRV11-A module; the user configures jumpers on the module for the chip type being used.

A partial listing of manufacturer's chips that will operate in the MRV11-A is given in Table 9-1.

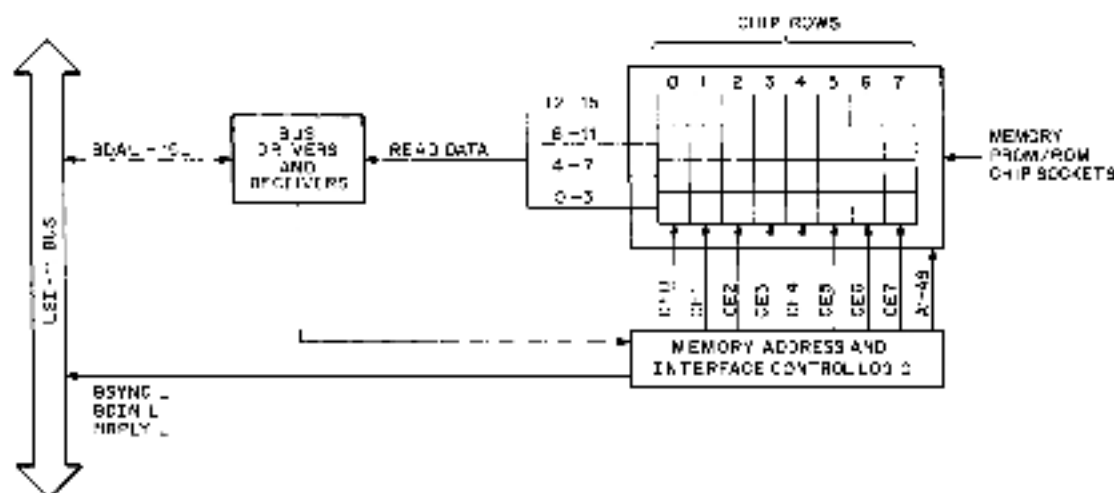

Figure 9-1 MRV11-A Read-Only Memory

Table 9-1
MRV11-A Chips

Manufacturer or Source	512 by 4-Bit Chips		256 by 4-Bit Chips	
	Model/Type	PROM/ROM	Model/Type	PROM/ROM
Digital Equipment Corp.	MRV11-AC	PROM	—	—
Intersil	IMS624	PROM	IMS623	PROM
Signetics			8259	PROM

Chips used must be tristate output devices which conform to the device pinning, data, and addressing described in the remainder of this chapter.

The user can install chips in increments of four chips each. When using 512 by 4-bit chips, memory expansion is in 512-word increments. When using 256 by 4-bit chips, memory expansion is in 256-word incre-

ments. Jumpers on the MRV11-A can be cut by the user to prevent an incorrect BRPLY 1 signal from being generated when unpopulated locations are addressed on the module.

The information contained in the remainder of this chapter will enable the user to prepare the MRV11-A

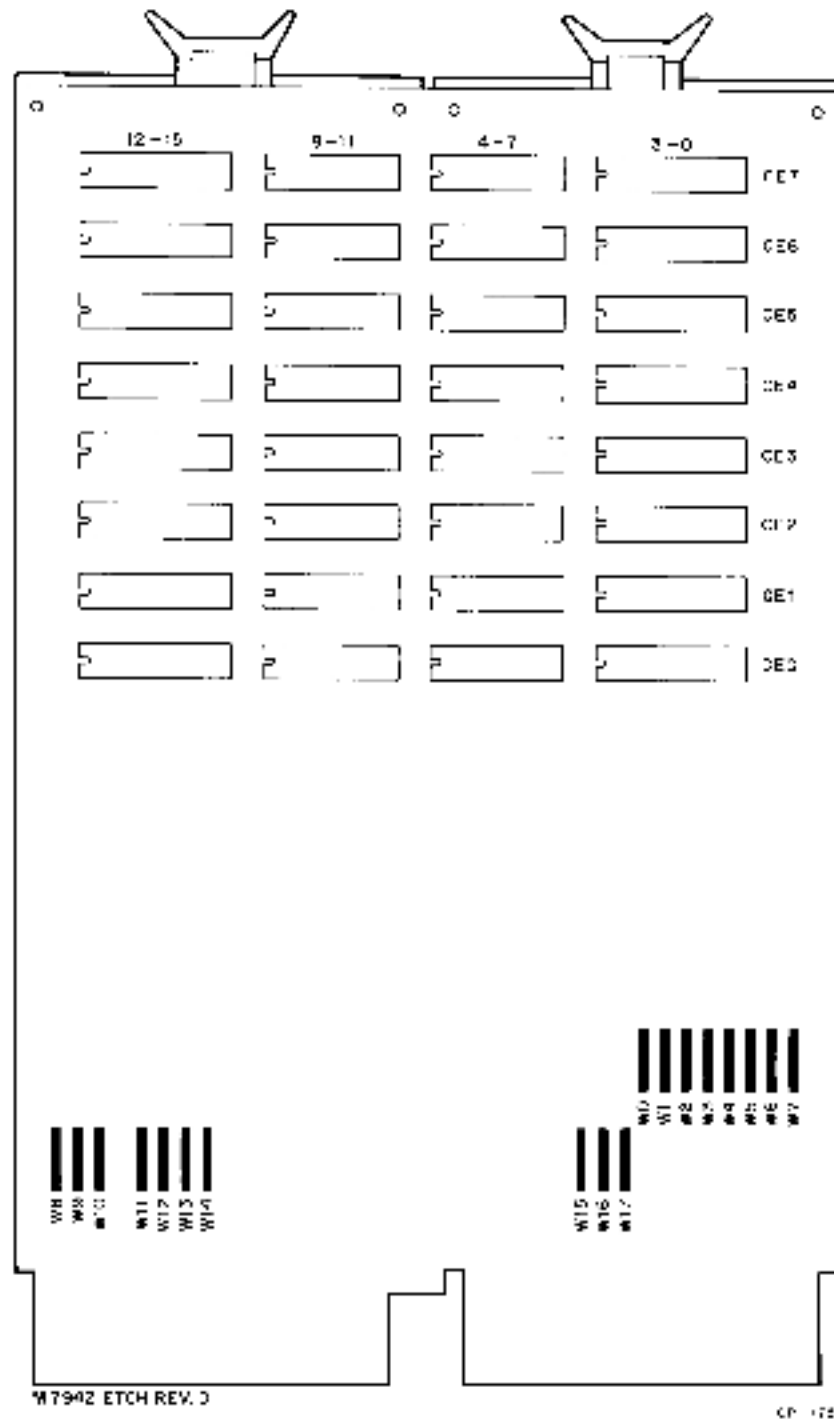

Figure 9-2 MRV11-A Jumper Locations

for use (jumper-selected addressing and chip selection) and includes information required for correct PROM and ROM programming.

9.2 JUMPER-SELECTED ADDRESSING AND CHIP TYPE

9.2.1 General

Jumpers which allow the user to select the 4K bank in which the module can be addressed and jumpers which allow the use of 512 by 4-bit or 256 by 4-bit PROM (or ROM) chips are provided on the MRV11-A. In addition, jumpers may be removed from the module to prevent the module from generating an active BRPLY L signal when a portion of the module is addressed that does not contain PROM or ROM chips. Jumpers are located as shown in Figure 9-2.

9.2.2 Chip Type Selection

The module is supplied with jumpers W8, W9, and W10 installed for use with 512 by 4-bit chips. When using 256 by 4-bit chips, W8, W9, and W10 must be cut or removed and jumpers W11 and W12 installed; in addition, either W13 (lower 2K) or W14 (upper 2K) must be installed to properly address the lower 2K or upper 2K address segment within the 4K memory bank.

9.2.3 Addressing and Reply

The user must consider both 4K bank address selection and BRPLY L signal generation when configuring a module for use. Chips (either PROM or ROM, 512 by 4 or 256 by 4) are arranged in eight physical rows (CE0—CE7) of four chips each. Entire rows can be unpopulated, allowing those addressed locations to be used by read/write memory contained on another module. When this is done, the BRPLY L jumpers (W0—W7) associated with the unused rows should be cut or removed to prevent the MRV11-A from returning a BRPLY L signal when those rows are addressed. A listing of octal addresses (within a 4K bank), physical rows, and BRPLY L jumpers is provided in Table 9-2; use data listed for the chip type being used.

The 4K bank in which the MRV11-A resides is programmed by connecting bank address jumpers W15—W17, as appropriate. The module is supplied with all bank address jumpers installed (bank 0). Jumpers installed represent logical 0s; jumpers not installed represent logical 1s.

Figure 9-3 illustrates addressing words used with the MRV11-A. Refer to the addressing format for the type of PROM or ROM chips being used.

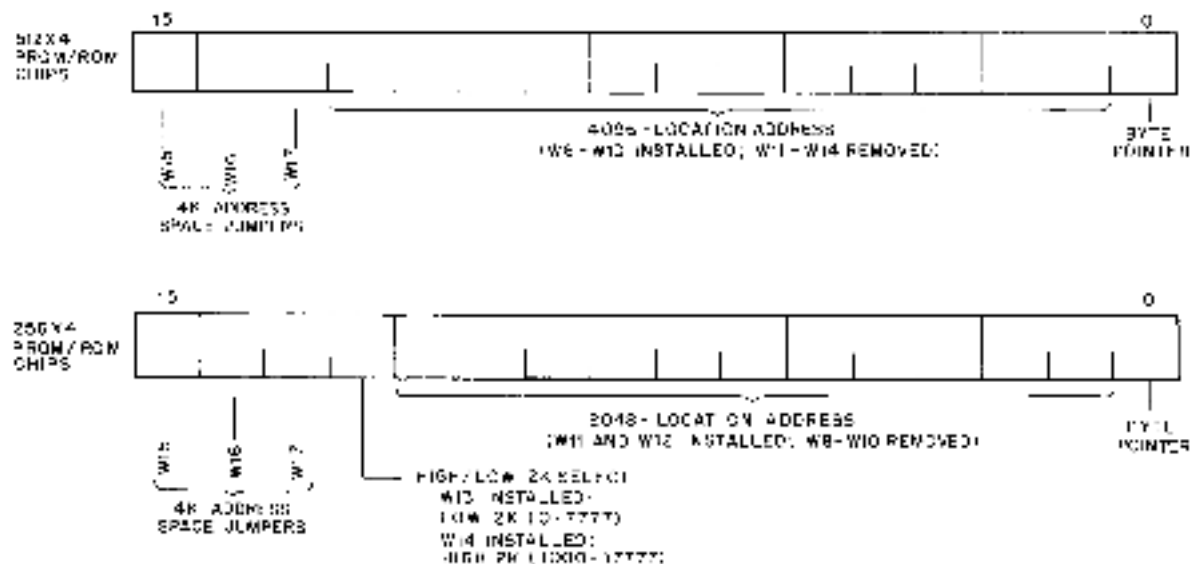

Figure 9-3 MRV11-A Address Word Formats

Table 9-2
PROM/ROM Chip Addressing Data

Bank Addr. Jumpers ^a			512 by 4 Chips			256 by 4 Chips				
W15	W16	W17	Word/Byte Address	Physical Row	BIPPLY L Jumper	Word/Byte Address		Physical Row	BIPPLY L Jumper	
						W13 Installed	W14 Installed			
I	I	I	0000-0000	CE0	W0	0000-0000	0000-0000	CE0	W0	
I	I	R	0000-0000	CE1	W1	0000-0000	0000-0000	CE4	W4	
I	R	I	0000-0000	CE2	W2	0000-0000	0000-0000	CE1	W1	
I	R	R	0000-0000	CE3	W3	0000-0000	0000-0000	CE5	W5	
R	I	I	0000-0000	CE4	W4	0000-0000	0000-0000	CE2	W2	
R	I	R	0000-0000	CE5	W5	0000-0000	0000-0000	CE6	W6	
R	R	I	0000-0000	CE6	W6	0000-0000	0000-0000	CE3	W3	
R	R	R	0000-0000	CE7	W7	0000-0000	0000-0000	CE7	W7	

^aR = jumper removed, I = Jumper installed

9.3 PROGRAMMING PROM AND ROM CHIPS

The actual procedure for loading data into PROM chips or writing specifications for masked ROM chips will vary, depending upon the chip manufacturer. These procedures are beyond the scope of this document. (See chip manufacturer's data sheets.) However, the user must be aware of the chip pins versus LSI-11 data bit relationship, and the chip pin versus memory address bits. Address and data pins are described below.

As previously discussed, chips are arranged in rows of four chips each. Each chip contains locations of four bits each. Hence, four chips are used to provide the 16-bit data word formats for each row. Rows are designated by their respective Chip Enable (CE0 - CE7) signals. Depending upon the chip type used, a row of four chips contains 512 or 256 16-bit read-only memory

locations. The actual chip within a row is designated by one additional digit (0, 1, 2, or 3). Hence, the data pins are assigned to LSI-11 bus bits as listed in Table 9-3.

Table 9-3
Data Pin Assignments

Chip Pin	Chip 0	Chip 1	Chip 2	Chip 3
9	BDAL3	BDAL7	BDAL11	BDAL15
10	BDAL2	BDAL6	BDAL10	BDAL14
11	BDAL1	BDAL5	BDAL9	BDAL13
12	BDAL0	BDAL4	BDAL8	BDAL12

Addressing of chips is shown in Figure 9-4. All chips used on the MRV11-A must conform to this information. Observe that the only difference between 512 by 4-bit and 256 by 4-bit chip pins is pin 14. The 512 by

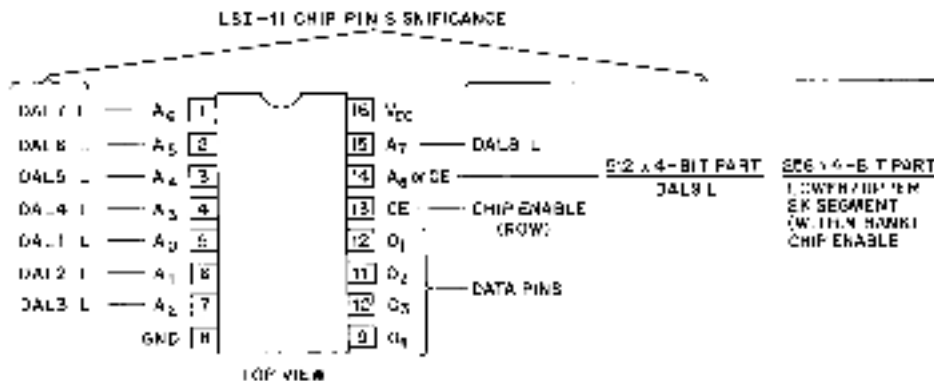

NOTE
Designations immediately adjacent to pins are typical designations used by chip manufacturers — not LSI-11 designations. LSI-11 designations for correct addressing are located away from the chip. Observe that these signals are low — not high. They are on-chip inverted bus signals (low = logical "1").

10-0129

Figure 9-4 PROM/ROM Chip Pin Addressing

4-bit part uses this pin for address bit DAL9; the 256 by 4-bit part uses this pin for a chip enable when both bank address and 2K segment address are true. Also note that bus address bits do not follow in sequence with chip manufacturer's address designations. The pinning arrangement shown allows for the use of commonly available PROM and ROM chips and optimum (compact) MRV11-A module layout.

9.4 PROGRAMMING RESTRICTIONS

Special care must be used when programming PROMs or ROMs for use with MTPS instructions and KEV11 option EIS instructions. These instructions fetch source operands via the DATIO bus cycle, rather than the DATI bus cycle. Hence, fetching a source operand from a PROM or ROM location will result in a bus

error (timeout) because the processor will attempt to write into the same location. When fetching MTPS or EIS instruction source operands, first MOVE the source operand from the PROM or ROM location to a general register. MTPS or EIS instruction can then be executed using the general register contents as the source operand. If desired, read-write memory could be used instead of the general register to temporarily store the source operand.

9.5 TIMING AND BUS RESTRICTION

Addressed memory read data is available within 120 ns after the BSYNC L signal is received by the MRV11-A. Logic on the module responds to DATI bus cycle only. DATO or DATOB bus cycles will result in a bus timeout error. Logic functions on the module are not affected by the bus initialize (BINIT L) signal.

CHAPTER 10

USER-DESIGNED INTERFACES

10.1 GENERAL

This chapter contains sample circuits and information which can be utilized in user designed hardware that is installed on the LSI-11 bus. The user must ensure that the circuit, as used in a particular application, conforms to the LSI-11 bus specifications included in Chapter 3. The various interface module and prewired backplane options previously described in this manual are designed for ease of user prototype development. However, in those applications that require a special interface module, hardware components listed in the *Hardware Accessories Catalog* will enable backplane connector-compatible systems to be rapidly assembled.

10.2 BUS RECEIVER AND DRIVER CIRCUITS

The equivalent circuits of LSI-11 bus-compatible drivers and receivers are shown in Figure 10-1. Any device that meets these requirements is acceptable. To perform these functions, Digital Equipment Corporation uses two monolithic integrated circuits with the characteristics listed in Table 10-1. A typical bus driver circuit is shown in Figure 10-2. Note that DEC 8641 quad transceivers can be used, combining LSI-11 bus receiver and driver functions in a single package.

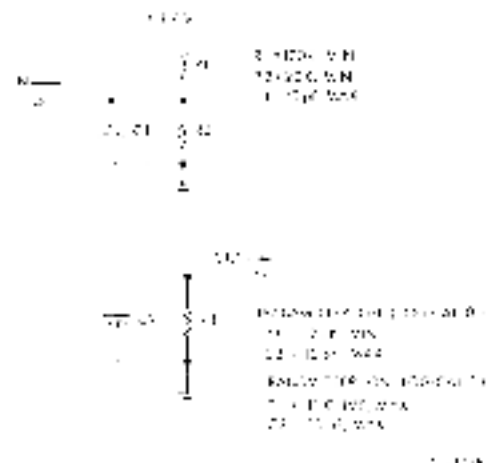

Figure 10-1 Bus Driver and Receiver Equivalent Circuits

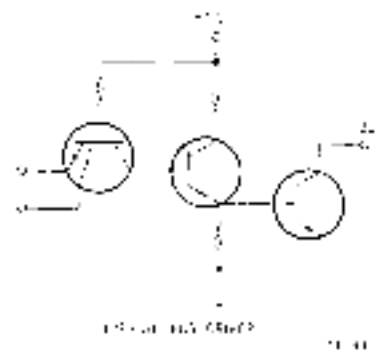

Figure 10-2 Typical Bus Driver Circuit

Table 10-1
LSI-11 Bus Driver, Receiver, Transceiver Characteristics

	Characteristic		Specifications	Notes
Receiver (DEC 8640, DEC 8641)	Input high threshold	V _{IH}	1.7 V min.	1
	Input low threshold	V _{IL}	1.3 V max.	1
	Input current at 2.5 V	I _{IH}	80 μA max.	1, 3
	Input current at 0 V	I _{IL}	10 μA max.	1, 3
	Output high voltage	V _{O11}	2.4 V min.	2

unique bus addresses for user-supplied I/O functions. Address bit 0 is a byte pointer which is only used for DATOB or the write portion of DATOB bus cycles.

Read data should be multiplexed using stored address bits SA1H and SA2H. In addition, an interface circuit that also includes interrupt logic should use VECTOR EN L to inhibit register read data and enable the interrupt vector transfer during the interrupt sequence.

Write data strobed for the four addressable device registers are produced by a 74155 dual 2:4 demultiplexer; however, other devices and circuits can be used. Both sections of the 74155 are simultaneously strobed by the WRITE DATA EN L signal. During word transfers, WB H is passive (low), enabling the DATA and DATB demultiplexer inputs. As a result of the logical state of stored address bits SA1 H and SA2 H, one Byte 0 and one Byte 1 write data strobe will go active, enabling writing into all 16 bits of the addressed device register. However, when outputting a byte to one of the registers, WB H goes active (high), enabling stored address bit 0 (SA0H and SA0L) to assert only one data input (DATA or DATB) on the 74155. Hence, only one of the eight write strobes will go to the active state: an 8-bit transfer to the appropriate high or low byte in the addressed register is thus completed.

10.4 INTERRUPT LOGIC

The basic logic functions required in an interrupt circuit are shown in Figure 10-4. This is a dual interrupt circuit which will enable and control two interrupt request sources (A and B) supplied by the user. The four flip-flops, ENABLE A and B, and INT REQ A and B comprise bits of one or two control/status registers (CSR). The set/reset status of the Enable flip-flops is established by a programmed output transfer. EN A CLK H and EN B CLK H signals are the write data strobes shown in Figure 10-3; EN A DATA H and EN B DATA H would then be two of the received data bits (DEC 8641 "Rn" outputs). Similarly, INT REQ A and B flip-flop outputs INT REQ A and INT REQ B would be read as bits in the CSR via the read data multiplexer in the device's logic.

A typical interrupt sequence for "device A" is described below. An interrupt is enabled under program control by setting the ENABLE A flip-flop. When the user's device is ready for service, it produces an active RQST A H signal, which is ANDed with ENABLE A. The AND gate output clocks the IAK ENH A flip-flop to the set state and IRQA L is produced. Note that if the user's device terminates the RQST A H signal, the

IRQA L signal will go low (false), causing BIRQ to go false. IRQA L is ORed with IRQB L and applied to a type DEC 8881 bus driver, asserting the BIRQ bus signal line. The processor responds by asserting BDIN L, producing a high DIN H signal. This signal clocks the device states (A or B requesting or not requesting service) into the IAK flip-flops. At a later time, the processor asserts BIAKI L, producing a high IAK H signal. IAK H is gated with the IAK flip-flop signals, giving the highest priority to Request A. If both are requesting service, the 7400 gate associated with the IAK A flip-flop \bar{Q} output goes low, clearing the IAK LNB A flip-flop, and producing VECTOR L and BRPLY L signals. VECTOR L is used for gating the vector address bits onto the I/O bus. With the device's IAK ENB flip-flop clear, it will not generate another interrupt until the device again requests service.

When not requesting service, both Interrupt Acknowledge (IAK) flip-flops remain cleared. The flip-flop Q outputs are both gated with IAK H, producing an active BIAKO L signal which is passed to the next (lower priority) device on the I/O bus. The INIT L signal, produced by a bus receiver and inverter, clears all Enable and IAK flip-flops, and presets (a don't care condition) all INT ENB flip-flops. When requesting service, the IAK flip-flops inhibit passing BIAKO L to the next lower priority device.

CAUTION

IAK flip-flops must function as synchronizers.
(Data setup has no guaranteed minimum time.)
Type 7474 and 74S74 are preferred.

10.5 DMA INTERFACE LOGIC

A simple DMA request circuit is shown in Figure 10-5. In addition to this circuit, bus address, word count, control/status registers, and burst transfer control logic would normally be included. All registers would be accessible via programmed I/O operations.

A DMA request is initiated by a device by producing an active REQ H signal. The RQST H signal must remain high until bus mastership is no longer required. The type DEC 8881 bus driver then asserts BDMR L.

The processor arbitrates the request by asserting BDMG L, setting the Claim flip-flop in the first requesting device along the BDMG daisy chain. The state of the Claim flip-flop is sampled by two gates after the DMG delay. CLAIM (0) H is low (false) and it inhibits the DMG0 ENH gate. Hence, when the Claim flip-flop is set, BDMG0 L is not passed to lower priority devices. The active (high) CLAIM (1) H signal is gated

with \overline{DDMG} H producing a low signal which enables one of the three 7427 gate inputs. When \overline{BSYNC} L and \overline{RPLY} L become negated, passive (low) \overline{SYNCR} H and \overline{RPLYR} H signals are gated with \overline{CLAIM} (1) H and the 7427 output goes high. This transition clocks the Master flip-flop to the set state producing the active \overline{MASTER} H signal, enabling \overline{BSACK} L and negating \overline{BDMR} L signals. \overline{MASTER} H is used by the DMA device to enable its bus cycle. \overline{BSACK} L informs the processor that the bus is in use. At the end of the bus cycle, the device negates \overline{REQ} H, clearing the Claim and Master flip-flops. \overline{MASTER} H and \overline{BSACK} L signals then go passive.

When not requesting DMA service, the device must pass \overline{BDMG} signals to lower priority devices on the I/O bus. The active (high) \overline{CLAIM} (0) H signal is gated with \overline{DDMG} H producing an active \overline{DMGOEN} H signal. This signal enables the \overline{BDMGO} L bus driver and \overline{DMG} H is gated onto the bus.

The actual \overline{DMG} delay is determined by the RC circuit shown on the figure, and should be 100 ns (min). \overline{BDMG} L initializes the circuit by clearing the Claim and Master flip-flops.

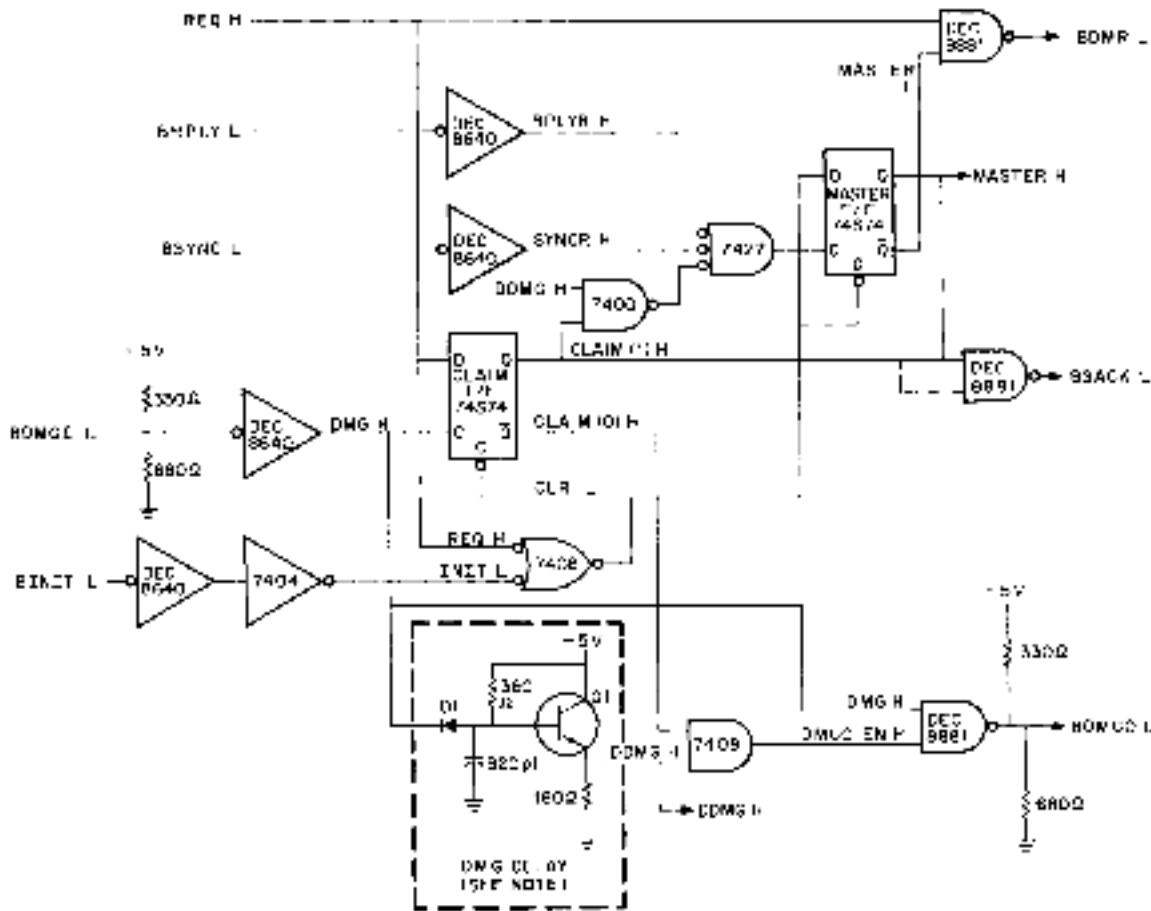

NOTE:
The DMG Delay Circuit shown above is preferred. However, the following DMG Delay Circuit can be used:

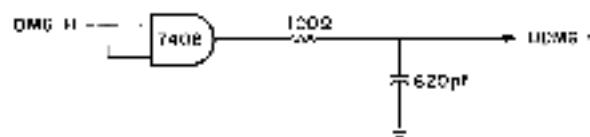

CP-1792

Figure 10-5 DMA Arbitration Logic

If dynamic MOS memory is used in the system (KD11-F processor and/or MSV11-B memory), a DMA device is restricted to one bus cycle for each BDMG signal from the processor. This must be done to allow the processor to execute memory refresh transactions. In systems which include dynamic MOS memory and use more than one DMA device, the DMA interface designer *must* ensure that sufficient time will be allowed for the processor to execute memory refresh transactions.

CAUTION

The Claim Flip-Flop must function as a synchronizer. (Data setup has no guaranteed minimum time.) Types 7474 and 74S74 are preferred.

CHAPTER 11

SYSTEM CONFIGURATION AND INSTALLATION

11.1 GENERAL

This chapter contains the basic considerations and requirements for configuring and installing LSI-11 or PDP-11/03 systems. The following paragraphs apply to both LSI-11 systems and PDP-11/03 systems, except where clearly stated otherwise.

11.2 CONFIGURATION CHECKLIST

LSI-11 and PDP-11/03 systems comprise user-selected module options as required for a particular application. Each module may require jumper alterations or switch settings to provide the correct addressing, operation, etc. for the user's application. A module configuration checklist for each module type is provided below. Detailed information for configuring the modules can be obtained by referring to the paragraphs listed in the checklist.

KD11 Processor Jumpers

- Power-up mode (Paragraph 5.2.4)
- Memory refresh enable (Paragraph 5.2.2)
- Line time clock enable (Paragraph 5.2.3)
- Resident memory 4K address selection (KD11-F only) (Paragraph 5.2.5)

DLV11 Serial Line Unit Jumpers

- Device address (Paragraph 6.2.2.2)
- Vector address (Paragraph 6.2.2.3)
- Universal asynchronous receiver/transmitter operation (Paragraph 6.2.2.4)
- Baud rate selection (Paragraph 6.2.2.5)
- EIA interface (Paragraph 6.2.2.6)
- 20mA current loop interface (Paragraph 6.2.2.7)
- Framing error halt (Paragraph 6.2.2.8)

DRV11 Parallel Line Unit Jumpers and Pulse Width Modification

- Device address (Paragraph 6.3.2.2)
- Vector address (Paragraph 6.3.2.3)
- NEW DATA READY and DATA TRANSMITTED pulse width modification (Paragraph 6.3.4.6)

MMV11-A Memory 4K Address Selection 4K address select switches (Paragraph 8.2)

MRV11-A PROM/ROM Memory Jumpers Memory address (Paragraph 9.2.3) Reply signal (Paragraph 9.3) 512 by 4-bit or 256 by 4-bit PROMs (Paragraph 9.2.2)

MSV11-A 1K by 16 Random Access Memory Address Jumpers (Paragraph 7.2)

MSV11-B 4K by 16 Random Access Memory Jumpers Memory address (Paragraph 7.3.1) Reply to refresh (Paragraph 7.3.2)

The following checklist is for LSI-11 system configurations. It includes items that are not contained on particular modules but which must be checked to ensure that the system is properly installed.

1. BDCOK, BPOK, B(F)VN1, and BHALT signals connected as required to H9270 backplane assembly (Paragraph 11.7.5).
2. Modules inserted in H9270 backplane slots according to desired priority (Paragraph 11.3).
3. Jumpers added to H9270 backplane when core memory (MMV11-A) is located between processor and I/O device modules (Paragraph 11.3.3).
4. Correct cabling selected for I/O device modules (Paragraph 11.5).
5. Modules inserted in backplane slots with components facing in the correct direction (Paragraph 11.4).
6. Correct power and ground inputs to H9270 backplane connector block (Paragraphs 11.7.3 and 11.7.4).

CAUTION

The LSI-11 modules and the backplane assembly mounting blocks may be damaged if the modules are plugged in backward.

DC power must be removed from the backplane during module insertion or removal.

11.5 I/O CABLING

Recommended I/O cable options for use with the DLV11 serial line unit and DRV11 parallel line unit are listed below:

DLV11 Serial Line Unit	Cable*
20 mA Current Loop	BC05M-X
EIA Interface	BC05C-X

DRV11 Parallel Line Unit	Cable*
---------------------------------	---------------

Any combination of one input and one output cable may be selected from the two types listed:

Flat Cable	BC08R-X
Twisted Pair	BC11K-25

11.6 PDP-11/03 INSTALLATION PROCEDURE

11.6.1 Packaging and Mounting

The PDP-11/03 is packaged as shown in Figure 11-4. It is designed with a removable front panel. Removing

*The -X in the cable number denotes length in feet, as follows: -1, -6, -10, -20, -25. For example, a 10-ft EIA interface cable would be referred to as BC05C-10.

the front panel exposes the LSI modules and cables. This enables replacement or installation of a module from the front of the PDP-11/03. The 11/03 power supply is located on the right-hand side of the PDP-11/03 when viewed from the front. The power supply contains three front panel switches and indicators which are accessible through a cutout in the front panel. Therefore, when the front panel is removed, the lights and switches are still attached and functional.

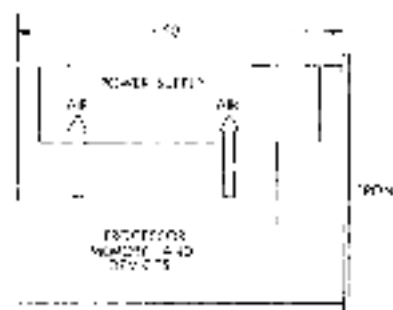
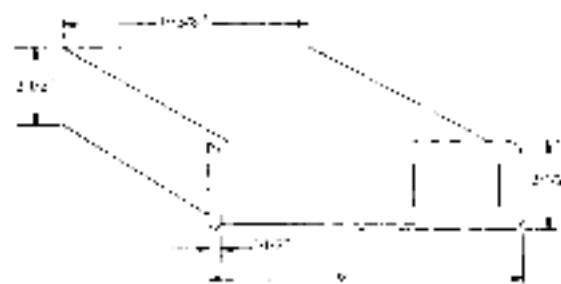

Figure 11-4 PDP-11/03 Backplane

Table 11-1
PDP-11/03 Input Power Electrical Specifications

Parameter	Model	Specifications
Input Power	PDP-11/03-AA or PDP-11/03-BA	100—127 Vac, 114 Vac nominal; 50 ± 1 Hz or 60 ± 1 Hz, single phase
	PDP-11/03-AB or PDP-11/03-BB	200—254 Vac, 230 Vac nominal; 50 ± 1 Hz or 60 ± 1 Hz, single phase
Input Power	All	400 W max at full load; 190 W typical
Temporary Line Dips Allowed	All	100% of nominal voltage: 9 to 20 ms 40% of nominal voltage: 20 to 96 ms 28% of nominal voltage: 96 to 500 ms

The PDP-11/03 is designed to mount in a standard 19 in. cabinet (Figure 11-5). A standard 19 in. cabinet has two rows of mounting holes in the front, spaced 18-5/16 apart. The holes are located 1/2 in. or 5/8 in. apart. Standard front panel increments are 1-3/4 in.

11.6.2 Power Requirements

Input (primary) power requirements are listed in Table 11-1.

An appropriate power cable and plug is supplied with all PDP-11/03 models. Note that a ground wire (and ground pin on the plug) must be connected to the normal service ground to ensure safe operation. Do not cut or remove the ground pin.

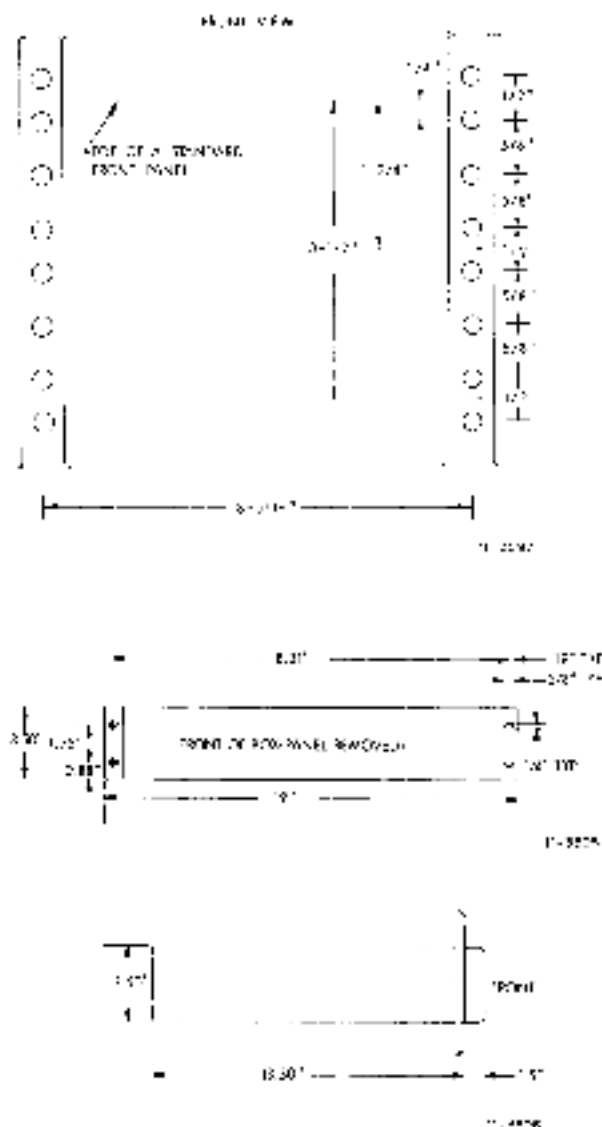

Figure 11-5 PDP-11/03 Cabinet Mounting

The H780 power supply provides the required dc power for the backplane in the PDP-11/03 enclosure. Typical dc power requirements will range from 33 to 120 W (max). In addition, the power supply generates the necessary BPOK H and BDCOK H power supply status signals, displays the RUN and DC status, and contains the ENABLE/HALT, DC ON/OFF, and LTC ON/OFF control switches.

Before attempting to operate the system, ensure that the system is configured as previously described in this chapter, and that environmental requirements are met.

11.6.3 Environmental Requirements

The PDP-11/03 will operate at temperatures of 41°F to 104°F (5°C to 40°C) with a relative humidity of 10 to 90 percent (no condensation), with adequate air flow across the modules. The fans in the H780 power supply will provide adequate air flow within the specified temperature range.

11.7 LSI-11 SYSTEM INSTALLATION

11.7.1 General

When installing the LSI-11 system, the user must mount the H9270 backplane, provide dc operating power, ground, and externally generated bus signals, and observe system environmental requirements. The following paragraphs describe the above items in detail.

11.7.2 Mounting the H9270 Backplane

The H9270 backplane (Figure 11-6) is designed to accept the KD11-F or KD11-J microcomputer and up to six I/O interface or memory modules. Mounting of the H9270 backplane can be accomplished in any one of three planes, as shown in Figures 11-7, 11-8, and 11-9.

11.7.3 DC Power Connections

11.7.3.1 Voltage and Current Requirements A power supply for a single backplane LSI-11 system should have the following capacity:

- +5 V \pm 2% load; 0—18 A static/dynamic
- +12 V \pm 2% load; 0—2.5 A static/dynamic
- +5 ripple: less than 1% of nominal voltage
- 12 ripple: less than 150 mV pp (frequency 5 kHz)

NOTE

Regulation at the H9270 backplane must be maintained to the specifications listed in Table 2-1.

11.7.4 H9270 Backplane Ground Connection

Connect the H9270 backplane ground wire to system (or frame) ground in which the H9270 is installed. The ground terminal is located as shown in Figure 11-10.

11.7.5 Environmental Requirements

All LSI-11 modules will operate at temperatures of 41° to 122° F (5° to 50° C) with a relative humidity of 10 to 90 percent (no condensation), with adequate air flow across the modules. When operating at the maximum temperature (122° F or 50° C), air flow must maintain the inlet to outlet air temperature rise to 12.5° F (7° C) maximum. Air flow should be directed across the modules as shown in Figure 11-12.

11.7.6 Externally Generated Bus Signals

11.7.6.1 General— Externally generated bus signals include BDCOK H and BPOK 11 power status, DEVNTL (line time clock) (if required), and BHALT L (if desired). The signals are applied to the backplane via a connector and an optional mating connector as shown in Figure 11-13. The signals must conform to LSI-11 bus configuration specifications described in paragraphs 3.12, 3.13, and 10.2. Connections made to the backplane via the ribbon cable shown in Figure 11-13 must not exceed 12 inches in length. Each signal is discussed in the following paragraphs.

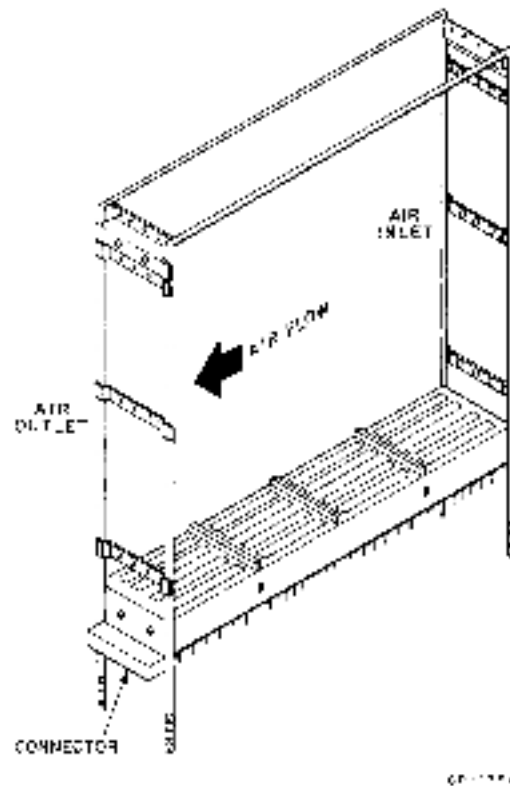

Figure 11-12 H9270 Backplane Air Flow

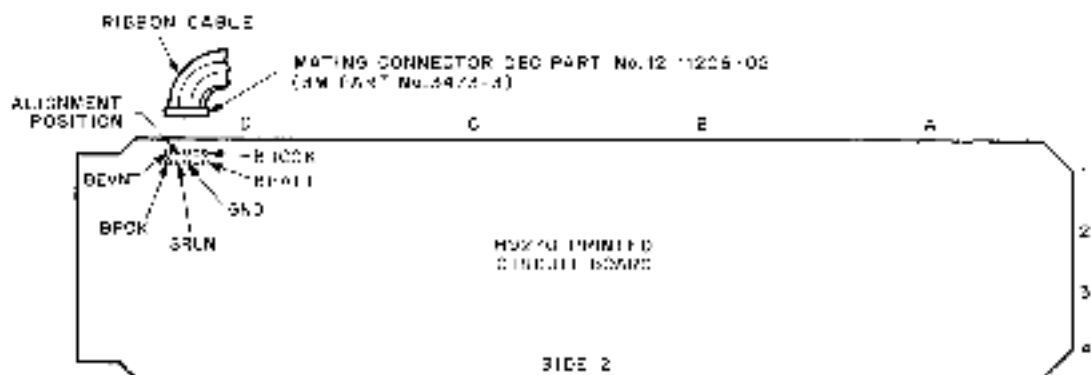

Figure 11-13 H9270 Backplane Printed Circuit Board

11.7.6.2 BDCOK H and BPOK H— The processor monitors power supply status and responds, as appropriate, by the BDCOK H and BPOK H signals. These signals are defined below:

BPOK H Assertion

8.0 ms of dc power reserve and BDCOK has been asserted for 70 ms min; 3.0 ms minimum assertion of BPOK required.

BPOK H Negation

4.0 ms of dc power reserve, but power is failing; 1.0 μ s minimum negation time for BPOK.

BDCOK H Assertion

3.0 ms of dc power has been applied; 1.0 μ s minimum assertion time for BDCOK.

BDCOK H Negation

5.0 μ s of dc power reserve but no sooner than 3.0 ms after BPOK negation; 1.0 μ s minimum negation time for BDCOK.

During the power-up sequence, after dc power has been applied (Figure 11-14), the processor asserts BINIT L in response to a passive (low) power supply-generated BDCOK H signal. When BDCOK H goes active (high), the processor terminates BINIT L after approximately 12 μ s, and waits for assertion (high) of BPOK; then the user-selected power-up mode is executed. Similarly, if power fails (Figure 11-15), the power supply-generated BPOK H signal goes passive (low) and causes the processor to push the PC and PS onto the stack and enter a power fail routine via vector location 24 (power fail trap location). The processor will execute the power fail routine until either BDCOK H goes passive (low), indicating the dc operating power may not sustain processor operation, or BPOK H returns to the active state. BINIT L will be asserted if BDCOK H goes passive.

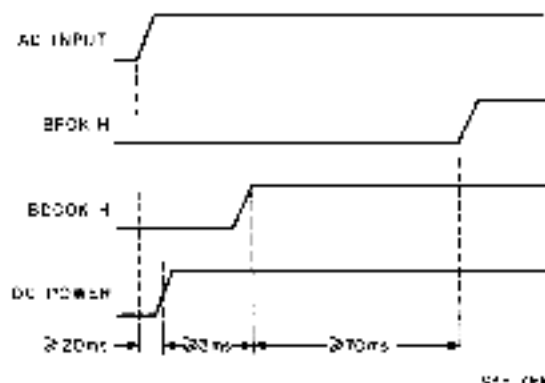

Figure 11-14 Power-Up Sequence

Generation of BPOK H and BDCOK H signals can be provided automatically via user-supplied logic, or manual operation can be selected, as follows:

Automatic: Connect BPOK H and BDCOK H signals from the power supply logic to H9270 backplane as shown in Figure 11-13.

Manual: Connect ground to a momentary ON/OFF switch (BDCOK switch), as shown in Figure 11-16. Connect the BDCOK switch output to the BDCOK H input on the H9270 backplane via a switch bounce eliminator. To initialize the processor after power is applied, the BDCOK switch must be momentarily depressed (off), then released (on).

NOTES

A switch bounce eliminator must be used with the manual BDCOK switch, as shown.

If the manual method of applying BDCOK H is selected, contents of semiconductor read/write memory may be lost when BDCOK switch is depressed.

NOTE

It is not necessary to negate the BPOK H signal when manually initializing the processor. BPOK H may be left unconnected.

11.7.6.3 BEVNT L Signal - The BEVNT L signal input to the H9270 backplane (Figure 11-13) is the external event interrupt. Asserting the BEVNT L signal initiates the LTC (line time clock) interrupt on the processor. The processor will trap through location 100_h if PS bit 7 = 0. A typical circuit for generating BEVNT L is shown in Figure 11-17.

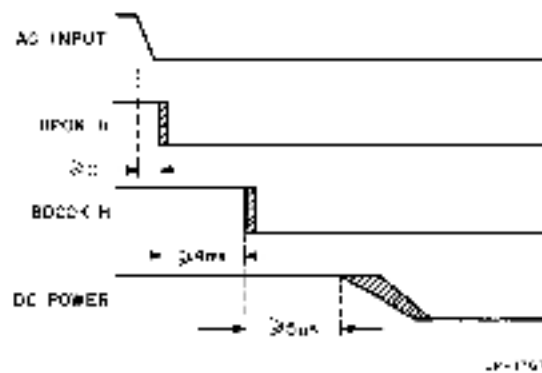

Figure 11-15 Power-Down Sequence

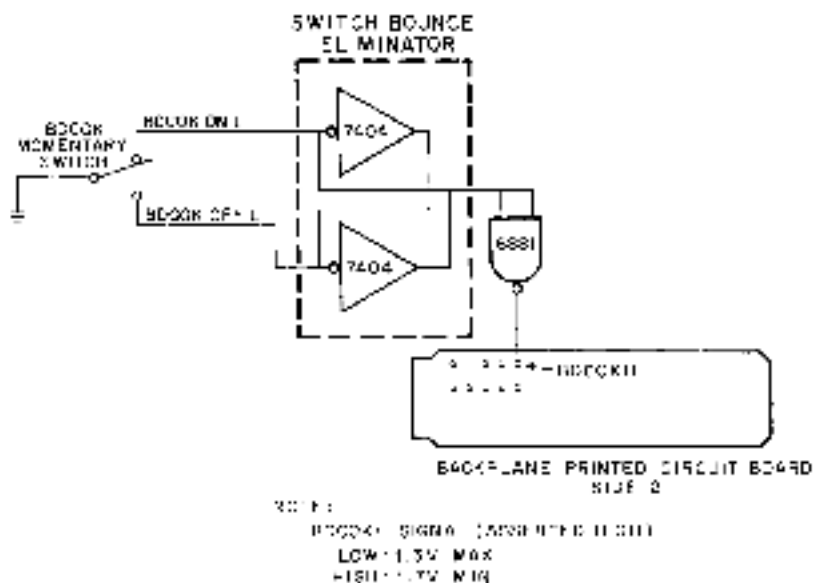

Figure 11-16 BDCOK H Signal Routing Diagram

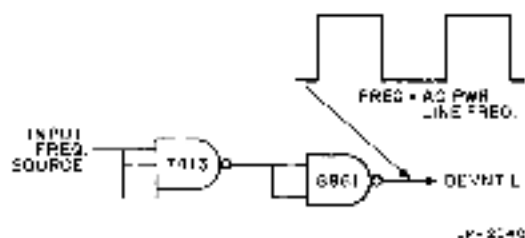

Figure 11-17 BEVNT L Signal

11.7.6.4 BHALT L Signal — Manual control of the Halt mode can be obtained by connecting a BHALT L signal line to the H9270 backplane printed circuit board as shown in Figure 11-13. The BHALT L signal level should meet bus specifications described in Paragraph 3.12.

When in the Halt mode, user program execution is not performed and the processor executes ODT console microcode. However, the processor will execute memory refresh in a normal manner and respond to DMA requests, even when BHALT is asserted; all device and LTC interrupt requests are ignored.

11.8 SYSTEM OPERATION

11.8.1 General

The procedures included in the following paragraphs describe power turn-on and operational checks for LS-11 and PDP-11/03 systems. Refer to the *LS-11, PDP-11/03 Processor Handbook* for detailed operation, including console ODT and program execution.

11.8.2 PDP-11/03 Power-On

Proceed as follows:

1. Ensure that the system is properly configured as previously described.
2. Place the DC ON/OFF switch in the down position (DC OFF).
3. Place the AC ON/OFF switch on the rear of H780 power supply in the ON position.
4. Place the HALT/ENABLE switch in the desired power-up position.

NOTE

The dc power can be applied with the HALT/ENABLE switch in either position. However, processor power-up mode is affected by this switch and jumper-selected power-up modes, as listed in Table 11-4.

5. Place the LTC ON/OFF switch in the OFF position.
6. Place the DC ON/OFF switch in the up (DC ON) position. The console device should respond with a printout (or display) as shown in Table 11-4.
7. Proceed with initial power-on checkout by entering and executing the program listed in Paragraph 11.8.4.

Table 11-4
Console Power-Up Printout (for Display)

Conditions	Mode 0 (Jumpers W5, W6 removed)	Mode 1 (Jumper W6 removed, W5 installed)	Mode 2 (Jumper W6 installed, W5 removed)	Mode 3 (Jumper W5, W6 installed)
BHATTI (unasserted), Core Memory	Processor will execute program in core. (See Note 2.)	Terminal will print out a random 6-digit number, which is the contents of the program counter.	Processor will execute program at location 173000. (See Note 2.)	No printout at terminal.
BHATTI (asserted), Core Memory	Processor will execute program in core. (See Note 2.)	Terminal will print out a random 6-digit number, which is the contents of the program counter.	Processor will execute program at location 173000. (See Note 2.)	No printout at terminal.
BHATTI (asserted), Dynamic RAM	Processor will execute program. If there is no data in memory terminal will print out "000 002." (See Note 2.)	Terminal will print out a random 6-digit number, which is the contents of the program counter.	Processor will execute program at location 173000. (See Note 2.)	No printout at terminal.
BHATTI (asserted), Dynamic RAM	Processor will execute program. If there is no data in memory terminal will print out "000 002." (See Note 2.)	Terminal will print out a random 6-digit number, which is the contents of the program counter.	Processor will execute program at location 173000. (See Note 2.)	No printout at terminal.
BHATTI (asserted), Core Memory	Terminal will print out contents of memory location U24 (normally "000 000"). (See Note 2.)	Terminal will print out a random 6-digit number, which is the contents of the program counter.	Processor will execute program at location 173000. (See Note 2.)	No printout at terminal.
BHATTI (asserted), Core Memory	Terminal will print out contents of memory location U24 (normally "000 000").	Terminal will print out a random 6-digit number, which is the contents of the program counter.	Processor will execute program at location 173000. (See Note 2.)	No printout at terminal.

NOTES

1. If mode 3 is selected, and microaddress (3000—3777) is not implemented, the processor will trap to memory location 010. Trapping to 010 will be treated as a reserved instruction trap.
2. Whenever the PDP-11/03 is executing a program, the RUN indicator should be lit. If no program is provided or if a HALT instruction is executed, the RUN indicator will be extinguished.

11.8.3 LSI-11 Power-On

Proceed as follows:

1. Ensure that there is no dc power applied to the H9270 backplane.
2. Remove all modules from the backplane.
3. It is recommended that a single switch be used to apply +5 V and +12 V to the H9270 backplane. There is no required voltage application sequence.
4. Turn power-on.
5. At the H9270 backplane, check for the following voltages:
 - Row 1, Slot A, Pin A2: +5 V
 - Row 1, Slot A, Pin D2: -12 V
 - Row 1, Slot A, Pin V1: +5 V

CAUTION

Do not plug in modules with power applied to H9270 backplane.

6. Turn power off.
7. Ensure that the system is properly configured and installed as previously described.
8. Turn on system power. Observe that the console device responds as described in Table 11.4.
9. Proceed with initial power-on checkout by entering and executing the program listed in Paragraph 11.8.4.

11.8.4 ASCII Character Console Printout Program

The following is a program that can be used to printout ASCII characters. The successful completion of this program can be used as a guide in determining the correct operation of the following:

KD11-F or -J Processor
DLV11 Serial Line Unit
LSI-11 data transfer and data control bus signals
Power input connections for +12 V and -5 V

This program does not explicitly check the following bus signals.

BDMR L	BHALT L	BSACK I.
BPOK H	BIRQ L	
BDMGT/O L	BDCOK H	
BEVNT L	BIACK/O L	

This program outputs all ASCII characters and may include control codes for specific devices.

Enter and execute the program via the console device as directed below:

1. Enter Starting address.
2. Press slash (/).
3. Enter instruction (octal code).
4. Press LINE FEED.
5. Repeat above steps until all instructions have been entered.
6. Press RETURN.
7. Enter starting address.
8. Press G.
9. Press the BREAK key on the console device to stop program. If the console device does not include the BREAK key, press the HALT switch (PDP-11/03 panel or the manual HALT switch described in Paragraph 11.7.b.4).

A sample console printout of the above program is shown in Figure 11-18.

11.9 PAPER TAPE SYSTEM OPERATION

11.9.1 General

Paper tape systems include no mass storage devices and programs must be read into system memory prior to system operation. Programs are read from punched paper tapes using either an optional low-speed reader, such as the L1-33 Teletypewriter, or a high-speed reader (user-supplied). The normal sequence of operations is:

1. Load the Absolute Loader
2. Load program tapes
3. Execute the program

11.9.2 References

Various paper tape software options are available for PDP-11 users. Refer to the following publication for program descriptions and operating instructions:

PDP-11 Paper Tape Software Programming Handbook (DEC-11-XPTSA-B-D).

The above manual can be ordered as directed at the rear of this manual.

Address/Instruction	Mnemonic
Starting Address	001000/105737
	001002/177564
	001004/100375
	001006/110037
	001010/177566
	001012/005200
	001014/000137
	001016/001000

```

1000G !"#%&'()*+,-./0123456789:;<=>?@ABCDEFGHIJKLMNPUQRS■
!"#$%&'()*+,-./0123456789:;<=>?@ABCDEFGHIJKLMNPUQRS■
!"#$%&'()*+,-./0123456789:;<=>?@ABCDEFGHIJKLMNPUQRS■
!"#$%&'()*+,-./0123456789:;<=>?@ABCDEFGHIJKLMNPUQRS■
!"#$%&'()*+,-./0123456789:;<=>?@ABCDEFGHIJKLMNPUQRS■
!"#$%&'()*+,-./0123456789:;<=>?@ABCDEFGHIJKLMNPUQRS■
!"#$%&'()*+,-./0123456789:;<=>?@ABCDEFGHIJKLMNPUQRS■
!"#$%&'()*+,-./0123456789:;<=>?@ABCDEFGHIJKLMNPUQRS■
!"#$%&'()*+,-./0123456789:;<=>?@ABCDEFGHIJKLMNPUQRS■
!"#$%&'()*+,-./0123456789:;<=>?@ABCDEFGHIJKLMNPUQRS■

```

Figure 11-18 Sample Console Printout

11.9.3 Loading the Absolute Loader

The Absolute Loader program tape is loaded using the Bootstrap Loader which is resident in the processor's microcode. The Bootstrap Loader is executed via the Halt mode and console ODT commands as directed below:

1. Enter the Halt mode
 - PDP-11/03 — Place the HALT/ENABLE switch in the HALT position. The console device prints the @ prompt character.
 - LSI-11 — Since LSI-11 systems are completely user-configured, the HALT mode can be entered via one or more of the following means:
 - a. Momentarily place the user-supplied HALT/ENABLE switch in the HALT position; return the switch to the ENABLE position.
 - b. Press the BREAK key on the console device (FEH jumper must be installed in the console SLU interface module).
 - c. Initialize the processor by momentarily negating BDCOK II (processor module jumper W5 must be installed and W6 removed).
2. Place the Absolute Loader tape (DEC-11-CA11J-A-PO) on the paper tape reader. Note that a long portion of the tape is punched with the octal value 351 (Channels 8, 7, 6, 4, and 1 are punched); position the tape so that any of those characters is located over the reader head.

- J. Enable the tape reader as follows:
 - 1. T33 Teletypewriter
 - a. Enable the low-speed reader by placing the LINE/OFF/LOCAL switch in the LINE position.
 - b. Place the START/STOP/FREE switch in the START position.
 - High-Speed Reader — Turn the reader on and place "on line", as appropriate for the type of reader being used.
4. Enter the reader's CSR address by typing the value on the console device. For example, if the console device includes a paper tape reader (such as the T.33 low-speed reader), type:
 - @ 177560

NOTE

In the above example, and all examples which follow, characters printed by ODT are shown underlined. Characters entered by the operator are shown not underlined.

The value 177560 is the console device's CSR.

5. Load the Absolute Loader tape by typing L immediately after the reader device's CSR. The tape will automatically be read followed by printing the Absolute Loader's starting

RXV11 hardware includes the RX01 single or dual floppy disk drive, M7946 interface module, and BC05L-15 interface cable. Models are available for 115 V, 60 Hz and 230 V, 50 Hz operation.

RT-11 software is described in four publications:

RT-11 System Reference Manual (DEC-11-ORUGA-C-DN2)

RT-11 System Generation Manual (DEC-11-ORGMA-A-D)

RT-11 Software Support Manual (DEC-11-ORPGA-B-DN1)

RT-11 System Message Manual (DEC-11-ORMLA-A-D).

Refer to these documents for RT-11 system software operation. Manuals can be ordered as directed at the rear of this manual. The remainder of this discussion involves getting the PDP-11/03 or LSI-11 system running and responding to RT-11 Keyboard Monitor commands.

11.10.2 Using the RX01

The RX01 contains no operator controls or indicators other than the load door(s) on the front panel. The left drive on dual drive models is named DX0 and the right drive is DX1. Load the RT-11 diskette in the left (or only) drive; this drive (DX0) is called the SYSTEM device in RT-11 software.

NOTE

RT-11 can be bootstrapped and run on DX1 if DX0 is inoperative.

Additional details for the RX01 drive are included in the *RX8/RX11 Floppy Disk System Maintenance Manual* (EK-RX01-MM-PRE2). That manual covers hardware used with PDP8 and other PDP-11 systems. However, the RX11/RX01 interface is identical to the RXV11/RX01 interface, and the RX11 and RXV11 are software compatible.

11.10.3 RXV11 Bootstrap

11.10.3.1 General — The RXV11 bootstrap loader program loads the RT-11 monitor from disk into system memory. No RT-11 operation can occur until the monitor is contained in system memory. Bootstrapping ("booting") the system can be accomplished via a hardware implemented bootstrap in the REV11-A or REV11-C option, or it can be entered and executed via the console device.

11.10.3.2 Booting The System Using The REV11-A or REV11-C — The REV11-A or REV11-C implements the RXV11 bootstrap (and other bootstrap programs) in four pre-programmed ROM chips. When system power is applied, and LSI-11 processor Mode 2 power-up sequence is configured on the processor module, the system responds with a dollar sign (\$) on a new line. The operator then responds by typing the device to be bootstrapped, DX (or DX0) is disk drive 0; DX1 is the second drive in dual drive RXV11 systems. A normal sequence of operations from power up through booting DX0 is shown below:

```
SDX
RT-11SJ V02C-XX
```

␣

After executing the DX0 bootstrap, the system responds by displaying the RT-11 monitor in use (RT-11SJ or RT-11FB) and the particular version in use (V02C-XX); the version is changed as RT-11 software changes are implemented. Finally, a dot is displayed on the next line, indicating that the RT-11 Keyboard Monitor is ready to accept a command. The system is correctly booted and RT-11 programs can be executed as desired.

11.10.3.3 Booting The System Via The Console Device — When the REV11-A or REV11-C option is not included in the system, the operator must enter a bootstrap program via the console device. Place the processor in the Halt mode and proceed as shown below; observe that underlined characters are printed by the processor and non-underlined characters are entered by the operator:

```

01000-00000 12701 ALP
0C1000-00000 10267 ALP
0C1004-00000 13701 ALP
0C1006-00000 171170 ALP
0C1010-00000 120711 ALP
0C1014-00000 11170 ALP
0C1018-00000 112700 ALP
0C101B-00000 4111
0C1020-00000 00000 ALP
0C1024-00000 00000 ALP
0C1028-00000 00000 ALP
0C102B-00000 11110 ALP
0C102E-00000 11110 ALP
0C1030-00000 4111
0C1034-00000 420 ALP
0C1038-00000 00000 ALP
0C103B-00000 010211 ALP
0C103E-00000 01000 ALP
0C1040-00000 00011 ALP
0C1044-00000 1375 ALP
0C1048-00000 100756 ALP
0C1050-00000 00000 ALP
0C1054-00000 00000 ALP
0C1058-00000 00000 ALP
0C105B-00000 00071 ALP
0C105E-00000 00071 ALP
0C1060-00000 00000 ALP
0C1064-00000 00000 ALP
0C1068-00000 00000 ALP
0C106B-00000 00000 ALP
0C106E-00000 00000 ALP
0C1070-00000 00000 ALP
0C1074-00000 00000 ALP

```

␣ 4 2 4 2 4 2 4 2
␣ 4 2 4 2 4 2 4 2
ALP-100-1000
X.10-Keyboard Monitor

The bootstrap program can be started at location 1000. Enable the Run mode by placing the HALT/ENABLE switch (on the PDP-11/03 panel, or an equivalent LSI-11 switch) in the ENABLE position. Start the program using the G command as follows:

```
@1000G
```

After a few seconds the RT-11 monitor will be loaded in system memory. The monitor will identify itself on the console device by typing a message, such as: RT-11SJ V02X-XX. This printout is followed by the Keyboard Monitor prompt character (.) printed on the next line.

11.10.4 Using the RT-11

Requests for the desired RT-11 modules are always entered from the Keyboard Monitor. When executing a system program, control is normally returned to the Keyboard Monitor. The Keyboard Monitor can be entered at any time by simultaneously typing CTRL-C keys.

CAUTION

1. A temporary loss of power will abort RT-11 operation and the LSI-11 processor will power-up through the selected mode. RT-11 must be restarted. If the REV11-A or REV11-C option is used, the console device will display \$ and the system waits for the operator to specify the desired bootstrap (DX). If the REV11-A or REV11-C is not used, enter the bootstrap program and start at location 1000.
2. Halting the processor will cause the processor to abort RT-11 operation. When the processor halts it prints the address (PC) on the console device, followed by the prompt character @. RT-11 operation can continue by typing P. If desired, the system can be rebooted as previously described.

Table 12-1
LSI-11 Peripheral Options

Terminal Type	Model	Name	Teas Console Device	Display Capacity	I/O Speed (font rate)	BR/AR Key	Serial Interface Type	Required Interface Options
Keyboard Printer	LA30	DC Console	Yes	132 characters/line	100	Yes	20 mA loop optional EIA	HI V11, DC3M
Keyboard Printer and Paper Tape Reader/Punch	L135	Teletypewriter	Yes	132 characters/line	100	Yes	20 mA loop	HI V11, DC3M
Keyboard CRT Display	V108K	Alphanumeric Terminal	Yes	140 characters (17 characters/line)	100-2000	No	20 mA loop EIA	HI V11, DC3M
Keyboard/CRT Display	V150	DECscope	Yes	480 characters (60 characters/line)	15-9600	Yes	20 mA loop optional EIA	DI V11, BC3M
Keyboard/CRT Display	V152	DECscope	Yes	1920 characters (80 characters/line)	15-9600	Yes	20 mA loop or optional EIA	DI V11, BC3M
Data Entry Terminal (Decimal/Hexadecimal characters)	R101	DEC LINK	No	4 N, or 12 characters/character	100-400	No	20 mA loop EIA	DI V11, DC3M
Alphanumeric Data Entry Terminal	RT02 A	30 Character Keyboard	Yes, with limited Cursor Set	32 characters	100-300 (20 mA EIA)	No	20 mA loop EIA	DI V11, BC3M
Page Buffer Terminal	RT02 B	Alphanumeric Terminal	Yes	32 characters	100-300 (20 mA EIA)	No	20 mA loop EIA	DI V11, BC3M
Access to paper (The terminal is optional)	DF01 A	Access to options	All I/O characters of the terminal are returned		100-300		20 mA loop EIA	HI V11, DC3M

APPENDIX A MEMORY MAP

RESERVED VECTOR LOCATIONS

000 (RESERVED)
004 TIMEOUT & OTHER ERRORS
010 ILLEGAL & RESERVED INSTRUCTION
014 BPT INSTRUCTION AND T BIT
020 JOT INSTRUCTION
024 POWER FAIL
030 EMT INSTRUCTION
034 TRAP INSTRUCTION
060 CONSOLE INPUT DEVICE
064 CONSOLE OUTPUT DEVICE
100 EXTERNAL EVENT LINE INTERRUPT
244 FIS (OPTIONAL)
264 RXV11

RESERVED DEVICE ADDRESSES

165000
↓
165776
 REV11 ROM ADDRESSES

173000
↓
173776
 REV11 ROM ADDRESSES

177170 RXV11 (RXCS)
177172 RXV11 (RXDB)

177550 (PRS) }
177552 (PRB) } HIGH-SPEED
177554 (PPS) } PAPER TAPE
177556 (PPR) } READER/PUNCH

177560 (RCR) }
177562 (RBUF) } CONSOLE
177564 (XCSR) } DEVICE
177566 (XBUF) } REGISTERS

APPENDIX C 7-BIT ASCII CODE

Octal Code	Char	Octal Code	Char	Octal Code	Char	Octal Code	Char
000	NUL	040	SP	100	@	140	\
001	SOH	041	!	101	A	141	a
002	STX	042	"	102	B	142	b
003	ETX	043	#	103	C	143	c
004	EOI	044	\$	104	D	144	d
005	ENQ	054	%	105	E	145	e
006	ACK	046	&	106	F	146	f
007	BEL	047	'	107	G	147	g
010	BS	050	(110	H	150	h
011	HT	051)	111	I	151	i
012	LF	052	*	112	J	152	j
013	VT	053	+	113	K	153	k
014	FF	054	,	114	L	154	l
015	CR	055	-	115	M	155	m
016	SO	056	.	116	N	156	n
017	SI	057	/	117	O	157	o
020	DLE	060	0	120	P	160	p
021	DC1	061	1	121	Q	161	q
022	DC2	062	2	122	R	162	r
023	DC3	063	3	123	S	163	s
024	DC4	064	4	124	T	164	t
025	NAK	065	5	125	U	165	u
026	SYN	066	6	126	V	166	v
027	ETB	067	?	127	W	167	w
030	CAN	070	8	130	X	170	x
031	EM	071	9	131	Y	171	y
032	SUB	072	:	132	Z	172	z
033	ESC	073	;	133	[173	{
034	FS	074	<	134	\	174	
035	GS	075	=	135] or ^	175	}
036	RS	076	>	136	^	176	~
037	US	077	?	137	- or +	177	DEL

APPENDIX D

SUMMARY OF LSI-11 INSTRUCTIONS

WORD FORMAT



Bits	Name	Symbolic	Description
15-12	reg. addr.	R	(R) is address (ex. R0-R3)
11-8	register deferred	R	(R) is address
7-4	auto increment	(R)	(R) is addr. (R) + 1 or 2
3	auto-increment	(R)	(R) is addr. of word; (R) + 1
4	auto-decrement	(R)	(R) - 1 or (R) - 2 is addr.
1	auto-decrement	(R)	(R) - 2; (R) is addr. of word
8	index	X(R)	(R) + X is addr.
7	index deferred	X(R)	(R) + X is addr. of addr.

PROGRAM COUNTER ADDRESSING

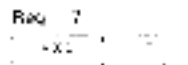

2	immediate	imm	operand n follows instr.
3	address	addr A	address A follows instr.
6	relative	A	instr. addr. + A - X is addr.
7	relative deferred	addr A	instr. addr. + A - X is addr. of addr.

LEGEND

Op Codes

■ = 0 for word/1 for byte
 Sd = source field (6 bits)
 Dd = destination field (6 bits)
 R = register (3 bits)
 XXX = offset (5 bits)
 +128 to +129
 N = number (3 bits)
 NN = number (5 bits)

Operations

| = contents of
 S = contents of source
 D = contents of destination
 r = contents of register
 ++ = increments
 X = relative address
 r = register definition

Boolean

A = AND
 V = OR
 X = XOR
 - = NOT

Condition Codes

- = conditionally set/cleared
 - = not affected
 C = cleared
 S = set

SINGLE OPERAND: OPR del

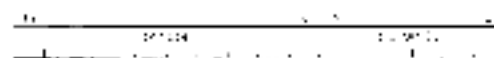

Mnemonic	Op Code	Instruction	dst Result	N	Z	V	C
General							
COM(B)	0500	clear	0	-	-	-	-
COM(B)	0510	complement (1's)	$\sim d$	-	-	-	1
INC(B)	0520	increment	$d + 1$	-	-	-	-
DEC(B)	0530	decrement	$d - 1$	-	-	-	-
NEG(B)	0540	negate (2's complement)	$\sim d + 1$	-	-	-	-
TST(B)	0570	test	d	-	-	-	0
Rotate & Shift							
RO(B)	0550	rotate right	$d \ll d$	-	-	-	-
RO(B)	0560	rotate left	$d \gg d$	-	-	-	-
ASR(B)	0580	arithmetic shift right	$d \gg d$	-	-	-	-
AS(B)	0590	arithmetic shift left	$d \ll d$	-	-	-	-
SWAB	0530	swap bytes	ab	-	-	-	0
Multiple Precision							
ADD(B)	0520	add carry	$d + D$	-	-	-	-
SBC(B)	0560	subtract carry	$d - D$	-	-	-	-
SAT	0570	sign extend	$d \ll 1$	-	-	-	0
Processor Status (PS) Operators							
MFPB	106700	move byte from PS	$d = PS$	-	-	-	0
MTPB	104488	move byte to PS	$PS = d$	-	-	-	-

DOUBLE OPERAND: OPR src, del OPR src, R or OPR R, del

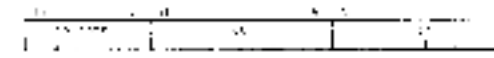

Mnemonic	Op Code	Instruction	Operation	N	Z	V	C
General							
MOV(B)	0500	move	$d = s$	-	-	-	-
CMP(B)	0580	compare	$s - d$	-	-	-	-
ADD	0550	add	$d + s - d$	-	-	-	-
SUB	0560	subtract	$d - d - s$	-	-	-	-
Logical							
BIT(B)	0580	bit test (AND)	$s \& d$	-	-	-	0
BIC(B)	0590	bit clear	$C \& (\sim S) \& d$	-	-	-	0
BIS(B)	0580	bit set (OR)	$d + s \& d$	-	-	-	-
XOR	0448	exclusive OR	$d + \sim C$	-	-	-	0

Optional EIS

MUL	071955	multiply	1 - 1 - 0 - 1
DIV	071954	divide	1 - 1 - 1 - 1
ASH	072958	arithmetically shift	1 - 1 - 1 - 1
ASHL	072958	arithmetically shift left completed	1 - 1 - 1 - 1

Optional FIS

FADD	07200F	floating add	1 - 1 - 0 - 0
FSLB	072007	floating subtract	1 - 1 - 0 - 0
FMUL	072008	floating multiply	1 - 1 - 0 - 0
FDIV	072004	floating divide	1 - 1 - 0 - 0

BRANCH: B - Location

If branch is asserted
Branch to location,
New PC ← Updated PC + (branch)
addr of br instr - 2

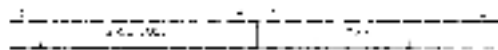

Op Code Base Code XXX

Mnemonic	Base Code	Instruction	Branch Condition
----------	-----------	-------------	------------------

Branches

BEQ	00000	branch if equal (Z=1)	Z=0
BNE	00100	branch if not equal (Z=0)	Z=1
BEQ	00100	branch if equal (Z=1)	Z=1
BPL	00000	branch if plus (V=0)	V=0
BML	00100	branch if minus (V=1)	V=1
BVC	00000	branch if overflow clear (V=0)	V=0
BVS	00100	branch if overflow set (V=1)	V=1
BCC	00000	branch if carry clear (C=0)	C=0
BCS	00100	branch if carry set (C=1)	C=1

Signed Conditional Branches

BGE	00000	branch if greater or equal (N=V)	N=V=1
BLT	00100	branch if less than (N≠V)	N≠V=1
BGT	00000	branch if greater than (N≠V)	N≠V=0
BLE	00100	branch if less or equal (N=V)	N=V=1

Unsigned Conditional Branches

BHI	10000	branch if higher (C=Z)	C=Z=1
BLOS	10100	branch if lower or same (C=Z)	C=Z=0
BHS	10000	branch if higher or same (C=Z)	C=Z=0
BLC	10100	branch if lower (C=1)	C=1

JUMP & SUBROUTINE

Mnemonic	Op Code	Instruction	Notes
JMP	000DD	jump	PC ← dst
JBI	004DD	jump if branch interrupt	same as JMP
RTS	002DR	return from subroutine	use same R
MARK	005RV	mark	add 1 to sub return
SOB	007RNN	subtract 1 & L if ≠ 0	if = 0, then if (R) / 0; PC ← (dst) + (R) (2 x 5x)

TRAP & INTERRUPT:

Mnemonic	Op Code	Instruction	Notes
EMT	10400 to 10477	emul control trap (not for general use)	PC at 30, PS at 80
TRAP	10400 to 10477	trap	PC at 34, PS at 80
BPT	00300	breakpoint trap	PC at 14, PS at 16
INT	00300	input/output trap	PC at 20, PS at 12
RTI	00000	return from interrupt	
RTT	00000	return from interrupt	inhibit 1 bit trap

MISCELLANEOUS:

Mnemonic	Op Code	Instruction
HALT	00000	halt
WAIT	00000	wait for interrupt
RESET	00000	reset external bus (no operation)
NOI	00000	no operation

CONDITION CODE OPERATORS:

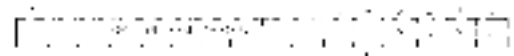

0 = CLEAR SELECTED COND. CODE BITS
1 = SET SELECTED COND. CODE BITS

Mnemonic	Op Code	Instruction	N	Z	V	C
CLC	00224	clear C	-	-	-	0
CLV	00222	clear V	-	-	0	-
CLZ	00244	clear Z	-	0	-	-
CLN	00250	clear N	0	-	-	-
CCC	00257	clear all cc bits	0	0	0	0
SCC	00231	set C	-	-	-	1
SEV	00232	set V	-	-	1	-
SEZ	00234	set Z	-	1	-	-
SEN	00230	set N	1	-	-	-
SCC	00227	set all cc bits	1	1	1	1

DDT COMMANDS

Format	Description
RETURN	Close opened location and accept next command.
LINE FEED	Close current location, open next sequential location.
n	Open only bus location.
n	Take contents of opened location, index by contents of P0 and open that location.
n	Take contents of opened location as absolute address and open that location.
n	Open the word at location n.
n	Reopen the last location.
\$n:n:Dir r:n or r:n	Open general register n (0-7) or R (R0 registers). Go to location n and start program.
n	Leave the bootstrap loader using the device CSR. Console device address is 17/560.
! or P	Proceed with program execution.
ABORT	Ends previous numeric operation. Response is a backslash (\).

APPENDIX E

H9270 BACKPLANE CONFIGURATIONS

E.1 BASIC DAISY CHAIN GRANT PRIORITY

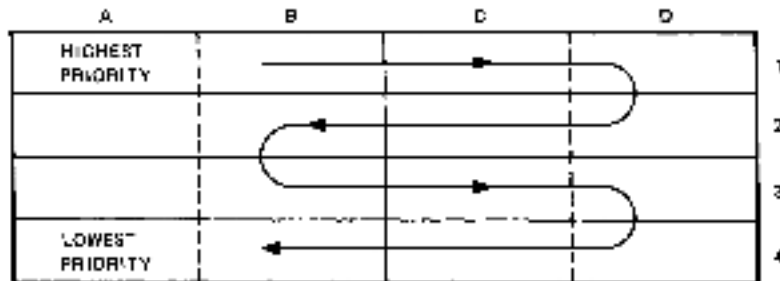

Note:
 Arrow indicates DDMG and BIAC daisy chain signal routing from highest priority device slot to lowest priority device slot on the backplane.

E.2 TWO BACKPLANE CONFIGURATION

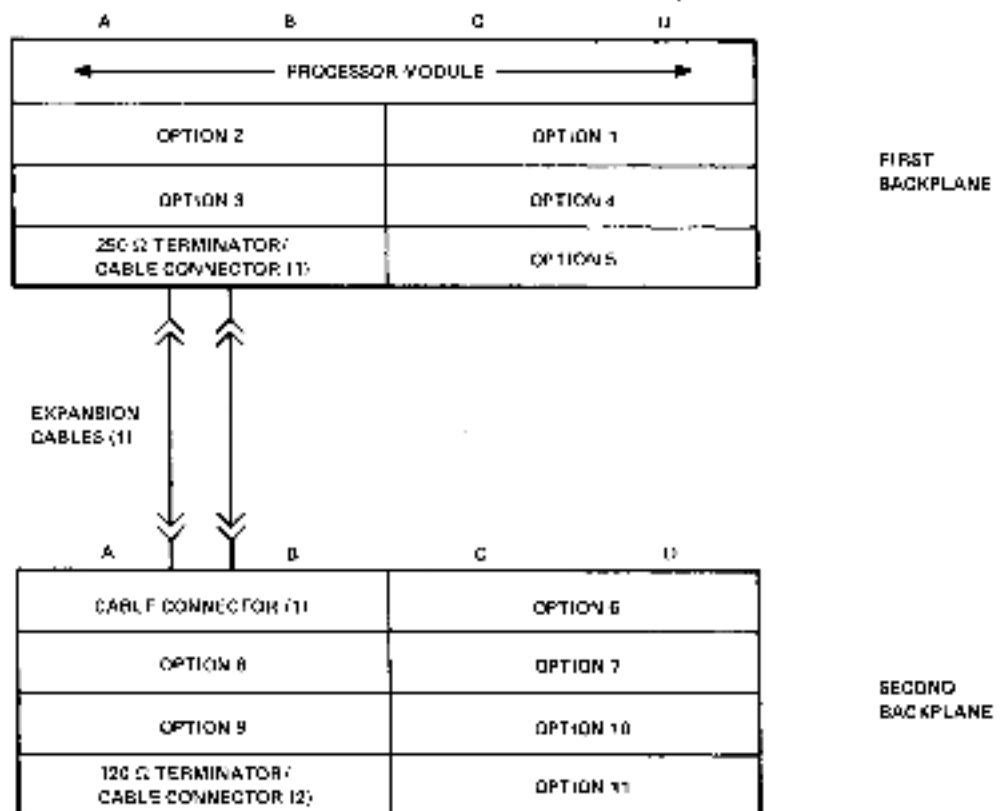

- Notes:*
1. Included in BCV 1B bus expansion option. (Cables are available in 2, 4, 6, or 12 ft. lengths.)
 2. Included in TEV11 bus terminator option.

E.3 THREE BACKPLANE CONFIGURATION

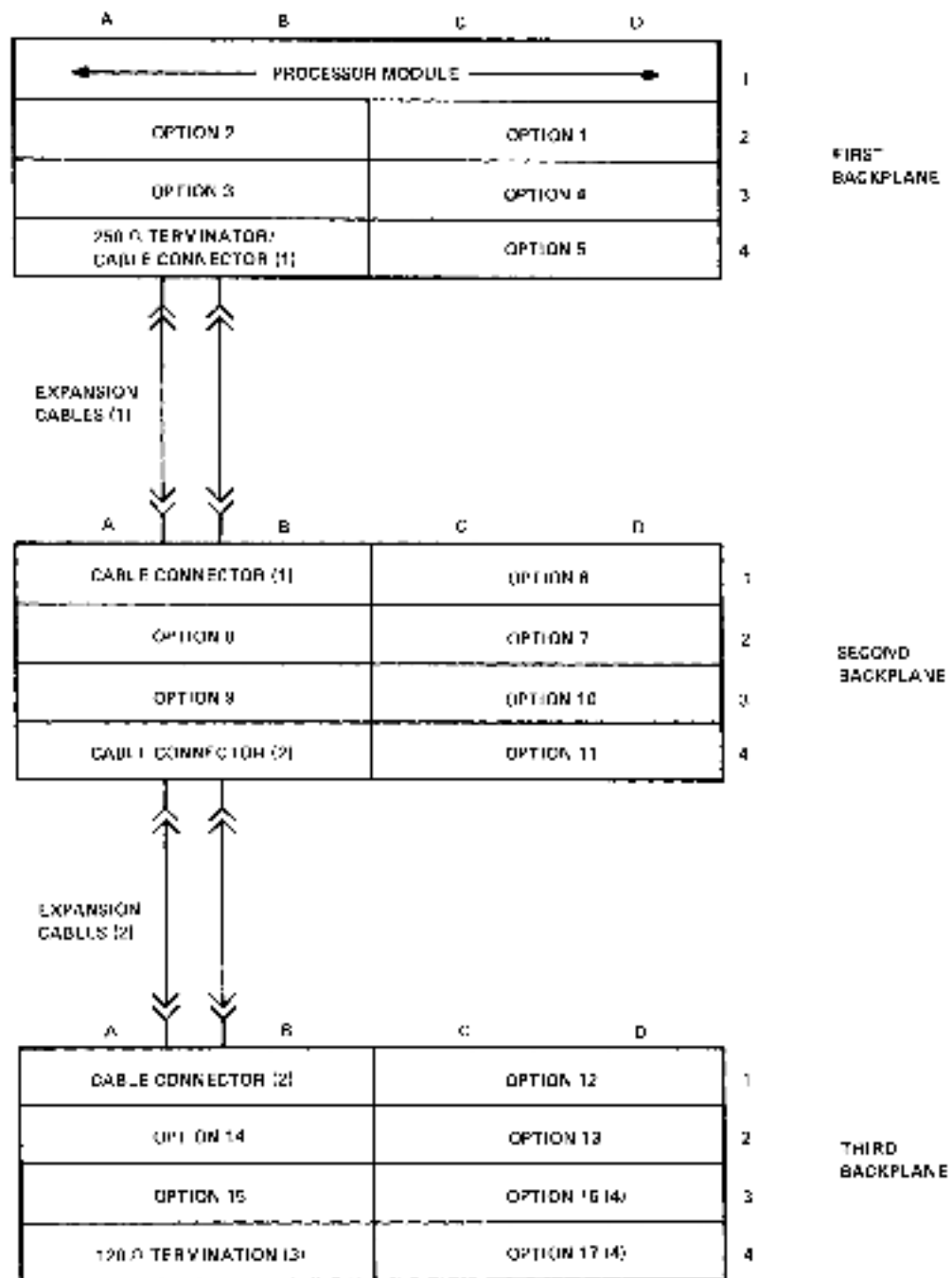

Notes:

1. Included in BCV 16 bus expansion option. (Cables are available in 2', 4', 8', or 12 ft. lengths.)
2. Included in BCV 1A bus expansion option. (Cables are available in 2', 4', 8', or 12 ft. lengths.)
3. Included in TEV 11 bus terminator option.
4. The LS11 Bus is restricted to 15 options, maximum. These option slots would only be used when previous option(s) occupy more than 1 option location.

APPENDIX F BUS INTERFACE I.C. PINS

**F.1 DEC 8640 QUAD 2-INPUT NOR GATES
(Bus Receiver)**

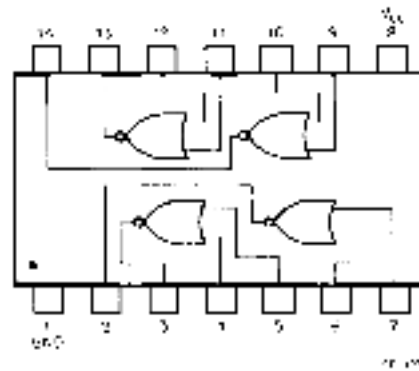

**F.2 DEC 8881 QUAD 2-INPUT NAND GATE
(Bus Driver)**

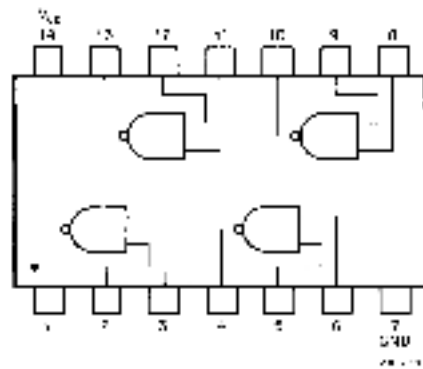

**F.3 DEC 8641 QUAD UNIFIED BUS TRANSCEIVER
(Bus Receiver/Driver)**

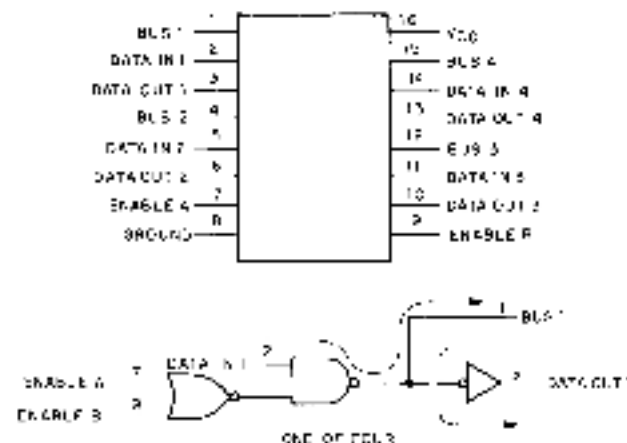

APPENDIX G LSI-11 BUS ACCESSORY OPTIONS INSTALLATION AND OPERATION

G.1 INTRODUCTION

G.1.1 General

Several LSI-11 bus accessory options are available for bus expansion, bus termination, DMA refresh, bootstrap read-only-memory (ROM), and combinations of the preceding. The options can be used in both LSI-11 and VDP-11/03 applications. A summary of the options is provided below:

<u>Option No.</u>	<u>Includes</u>	<u>System Functions</u>
REV11-A	M9400-YA Module	120 Ω bus terminator, DMA refresh, bootstrap ROM.
REV11-C	M9400-YC Module	DMA refresh, bootstrap ROM.
REV11-H	M9400-YH Module	DMA refresh, communication bootstrap ROM.
TEV11	M9400-YA Module	120 Ω bus terminator.
BCV1A-XX	Two BCCBL-XX cables, one M9400-YD module, and one M9401 module	Bus expansion: two expansion cables and two backplane connector modules (M9400-YD and M9401). Normally used for expansion from second to third backplane in 3-backplane systems. (A TEV11 120 Ω terminator must be installed in the last device slot in backplane 3.)

NOTE

The -XX in BCV1A-XX and BCV1B-XX options denotes cable lengths. Options are available with cable lengths of 2, 4, 6, and 10 feet. For example, a BCV1A-06 includes two 6-ft. cables.

<u>Option</u>	<u>Includes</u>	<u>System Functions</u>
BCV1B-XX	Two BC05L-XX cables, one M9400-YE module, and one M9401 module.	Bus expansion: 250 Ω terminator (M9400-YE), two expansion cables, backplane connector (M9401). Normally used for expansion from first to second backplane in 2 or 3 backplane systems.

G.1.2 Specifications

The general specifications (electrical and environmental) included in paragraph 2.9 also apply to the options described in this section. Dimensions of all modules associated with these options are 3 x 9.5 x 0.5 in. Power requirements are listed below. Note that power is obtained from the particular backplane in which a module is installed.

G.1.3 References

The following LSI-11, PDP-11/03 publications are available for configuring and using LSI-11 and PDP-11/03 systems:

LSI-11, PDP-11/03 Processor Handbook	EB 04870 05 060/-09/02 25
LSI-11, PDP-11/03 Configuration and Installation Guide	EK-LSI11-IN-001
LSI-11, PDP-11/03 User's Manual	EK-LSI11-UM-002

Table G-1

Option Power Requirements

Option Designation	+5V±5%	
	Typ	Max
REV11-A	1.64 A	2.24 A
REV11-C	1.0 A	1.89 A
REV11-H	1.0 A	1.89 A
REV11	0.54 A	0.70 A
BCV1A-XX:		
M9400-YD	0 A	0 A
M9401	0 A	0 A
BCV1B:		
M9400-YE	0.29 A	0.37 A
M9401	0 A	0 A

G.2 DESCRIPTION

G.2.1 General

The options described in this section generally involve variations of the M9400 module. By including selected components and jumpers, the various options are factory produced. Figures G-1 through G-6 each include a simple block diagram of the options, and functional position within a system, as appropriate. A list of options and figures is provided.

<u>Figure</u>	<u>Option</u>
G-1	REV11-A
G-2	REV11-C
G-3	REV11-H
G-4	REV11
G-5	BCV1A-XX
G-6	BCV1B-XX

Detailed descriptions of functions contained within these figures are contained in the following paragraphs.

G.2.2 Terminations

Two types of terminations are provided: 120Ω and 250Ω . Each bus signal line termination includes two resistors as shown in Figure G-7. Termination resistors are generally contained in 16-pin dual-inline packages which are physically identical to T.C. packages. Each package contains 16 terminations. The values used are shown in the figure. Daisy-chained grant signals are terminated and jumpered; BIAKI is jumpered to BIAKO L and BDMG1 is connected to BDMGO L via a factory-installed jumper (W1). Note that the 120Ω and 250Ω termination values are nominal; with the resistor values shown, the actual termination values will be approximately 124Ω and 222Ω , respectively.

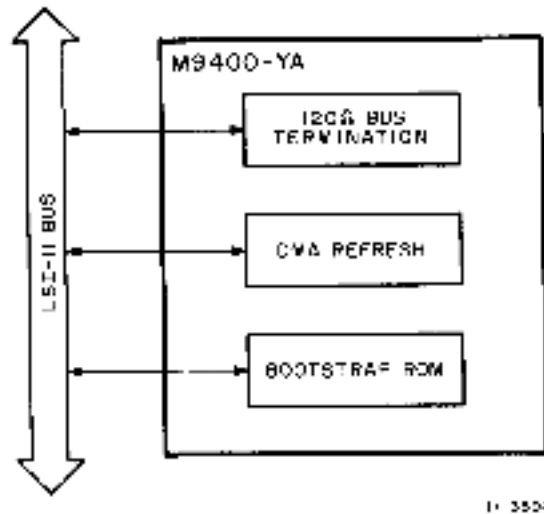

11-3554

Figure G-1 RBV11-A Functions

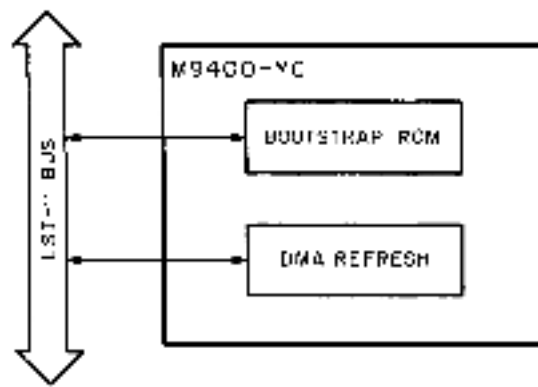

11-3595

Figure G-2 RBV11-C Functions

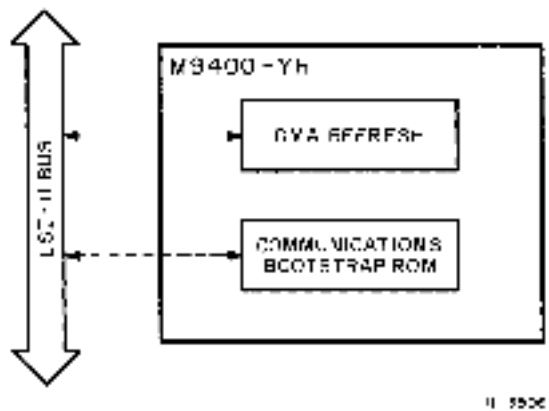

U-3506

Figure C-3 REV11-B Functions

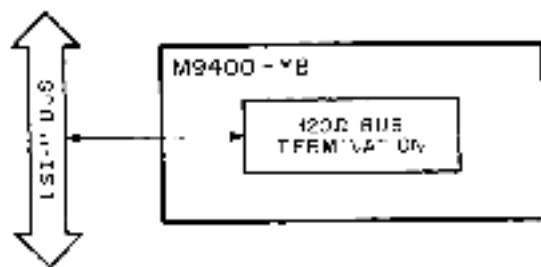

U-3507

Figure C-4 REV11 Functions

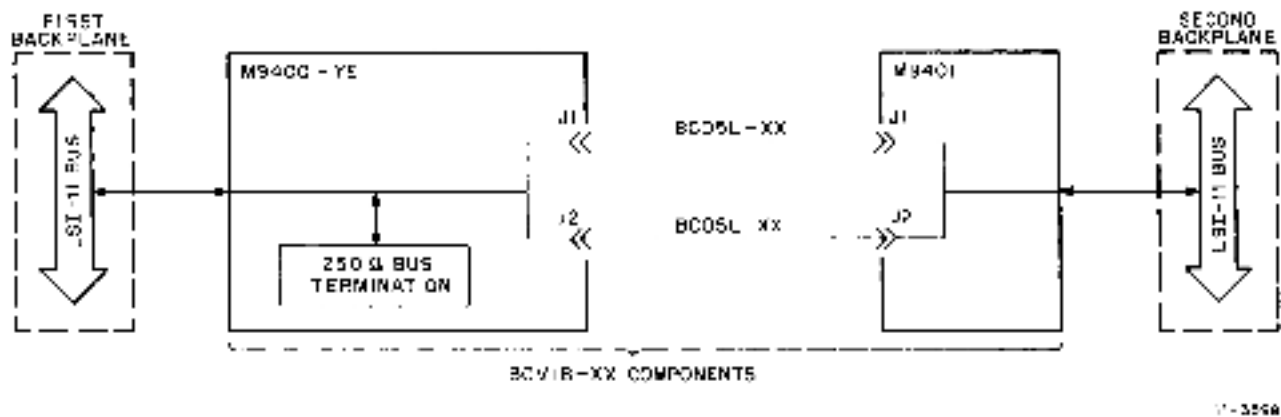

Figure G-5 BCVI B Functions

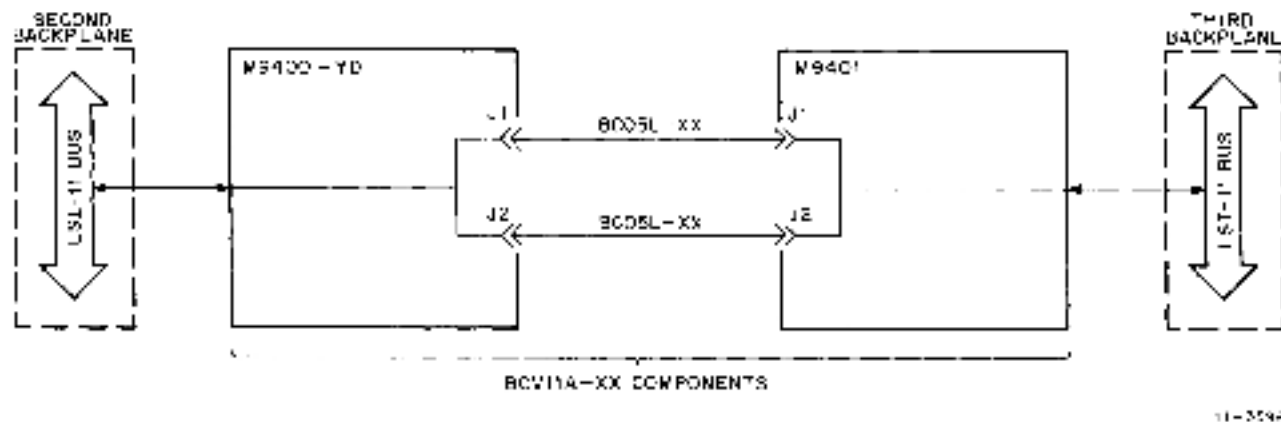

Figure G-6 BCVI A Functions

G.2.3 Bootstrap ROM Loader Logic

G.2.3.1 General - Bootstrap ROM loader logic is included in REV11-A, REV11-C, and REV11-D options. Logic functions on their respective M9400-YA, M9400-YC, and M9400-YH modules are identical. Bootstrap programs contained in the REV11-A and REV11-C ROMs are identical. However, the communications bootstrap programs contained in the REV11-D are different. Logic functions are described below.

G.2.3.2 Addressing - The module includes a 512 X 16-bit ROM array which is addressed in two 256-word segments. These address segments are reserved for REV11 options and reside in the upper 4K address bank, normally used for peripheral device addresses. The reserved addresses range from 165000-165776 and 173000-173776. A power-up mode which will cause the processor to access ROM location 173000 upon power up is jumper selectable on the KD11-F or KD11-J processor module.

Circuits associated with bootstrap ROM logic are shown in Figure G-8. Mixed inputs to an address comparator circuit reserve the ROM addresses. The address comparator responds to any of the reserved addresses during the addressing portion of a bus I/O cycle by generating an active MY BANK E signal. MY BANK E is ANDed with DTN H to produce a BRPLY E signal when the ROM word is read by the processor. MY BANK H is also inverted and applied to the ROM array chip enable inputs.

BA11-8 H and BA10 E address bits are stored in the 9-bit address latch on the leading-edge of SYNC R. The stored BA1-8 H and BA10 E address bits select the desired word location to be read within the two 256-word address segment detected by the address comparator.

G.2.3.3 Data Transfer - After the addressing portion of the bus DATA cycle has been completed, the ROM 0-15 H data becomes available on the BDAL bus driver inputs. Note that the ROM array consists of four 32 X 4-bit D.C.'s. Hence, the four 4-bit outputs comprise the 16-bit LSI-11 word. MY ENABLE L strobes the 16-bit word onto the I/O bus in response to the BIN H signal. The processor then receives the data, terminates BIN L, and the bootstrap ROM logic responds by terminating REPLY L and inhibiting the BDAL bus drivers.

G.2.3.4 Initialization - The bootstrap ROM logic is initialized only when BOOTEN goes false. This condition occurs during a power failure and produces active BD INIT H and BD INIT L signals. These signals clear the 9-bit address latch and circuits contained in the DMA refresh logic. The option does not respond to the LSI-11 bus BINIC L signal.

G.2.4 DMA Refresh Logic

G.2.4.1 General - DMA refresh logic consists of the three main functions shown in Figure G-9. Arbitration logic requests the I/O bus once every 30 usec. (approx.) and completes the required DMA

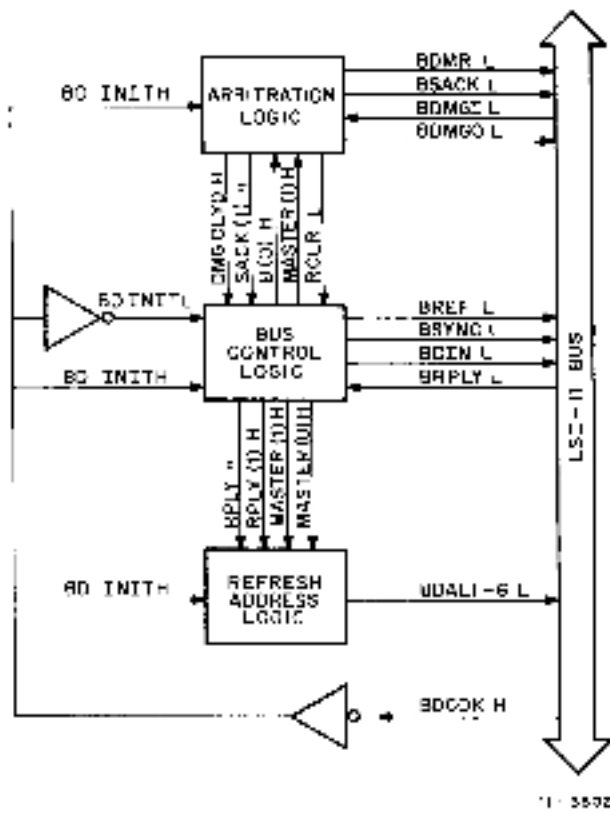

11-3532

Figure 3-9 DMA Refresh Logic

signal sequence with the processor. When it becomes bus master, it enables the bus control logic to execute a single refresh BSYNC L/BDIN L bus transaction simultaneously refreshing one row in all dynamic MOS memory chips contained in the system. The refresh address logic places a six-bit memory chip "row" address on the BDA₁ 1-6 lines during the addressing portion of the I/O bus cycle. Once the cycle has been completed, the row address is incremented by one for the next refresh cycle, and the I/O bus is released for non-refresh operations. The actual refresh transaction for one row address takes approximately 1.2 μ sec. Each dynamic MOS memory chip contains 64 row addresses. Hence, the DMA refresh logic is capable of refreshing all dynamic MOS memory contained in the system within the required 2 msec (maximum) period (i.e., 64 rows x 30 μ sec between refresh bus cycles = 1.92 msec).

G.2.4.2 Arbitration Logic - Arbitration logic is shown in Figure G-10; timing is shown in Figure G-11. The DMA refresh sequence is initiated once every 30 μ sec by a clock oscillator. GRAB BUS H is the clock output signal. It is inverted and gated with a ground (enable) signal, supplied via Refresh Disable jumper W2, to produce the REQ H signal. REQ H clocks the DMR flip-flop to the set state, producing active R PENDING (i) H and BDMR L signals. The processor arbitrates the DMA request and responds by asserting the daisy-chained BDMGI L signal when the present bus cycle is completed. BDMGI L is received and inverted, producing the active DMGR H signal. The leading edge of this

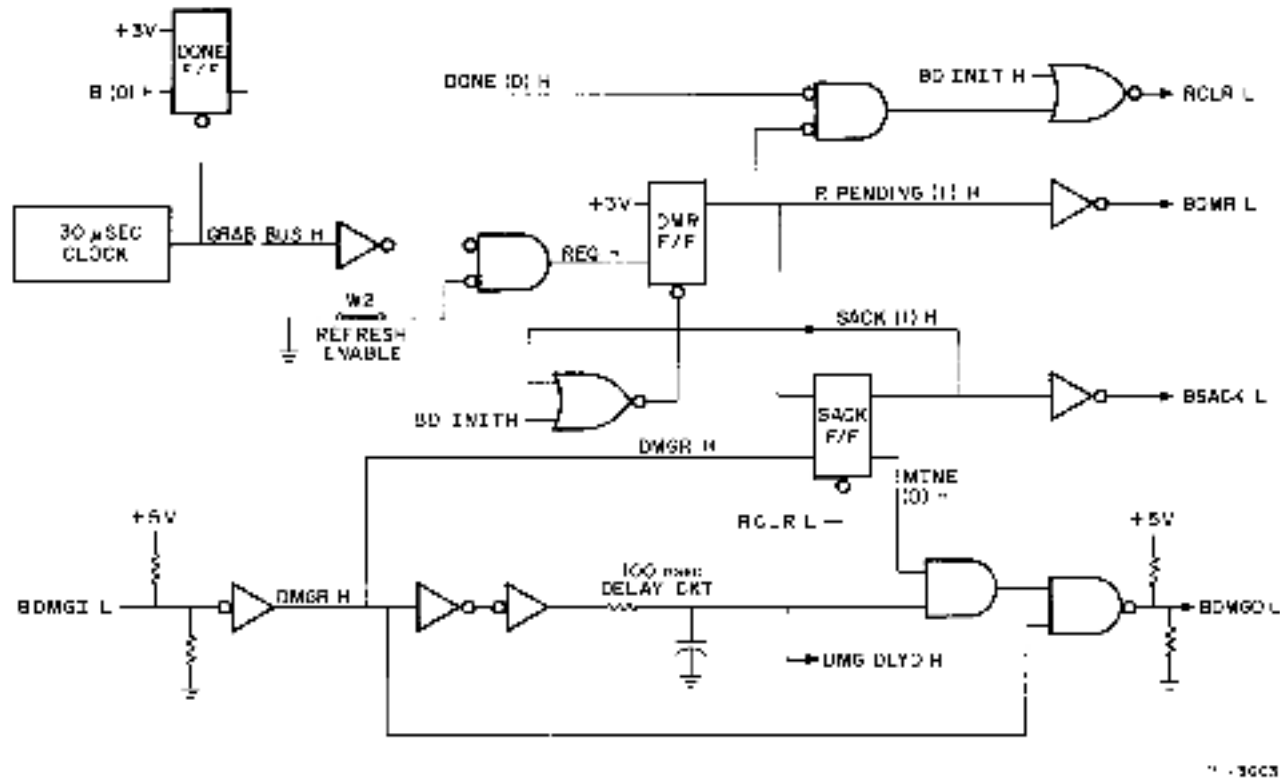

Figure G-10 Arbitration Logic

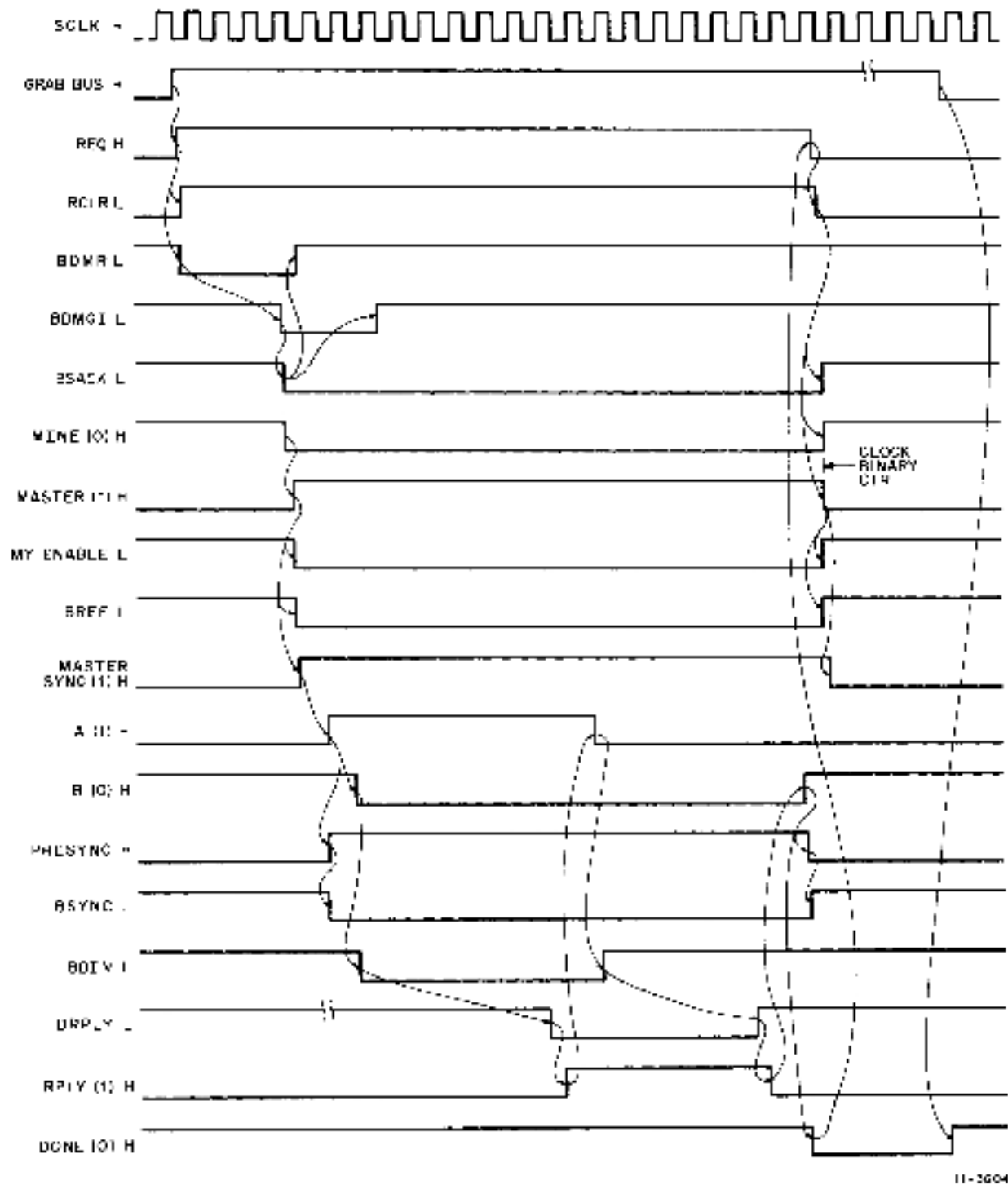

Figure G-10 DMA Refresh Logic Signal Sequence

signal clocks the active $\overline{\text{PENDING}}(1)H$ signal into the SACK flip-flop, causing it to go to the set state. $\text{SACK}(1)H$ goes high and $\text{MINE}(0)H$ goes low, clearing the DMR flip-flop and inhibiting the $\text{BDMGO}L$ signal logic, respectively. $\text{SACK}(1)H$ also turns on the $\text{BSACK}L$ bus driver; the active $\text{BSACK}L$ signal informs the processor that a DMA device has become bus master, and the DMA grant sequence is completed.

When not requesting the bus for a refresh bus transaction, the arbitration logic passes $\text{BDMGI}L$ signals to its $\text{BDMGO}L$ output so that the delay-chained signal continuity is maintained to the lower priority device requesting the bus. The active (high) $\text{MINE}(0)H$ signal enables generation of a delayed $\text{BDMGO}L$ signal. The 100 nsec. delay insures that the SACK flip-flop has sufficient time to go to the set state, if the DMA refresh option is requesting the I/O bus.

G.2.4.3 Bus Control Logic: - The bus control logic operation is initiated when the arbitration logic asserts the $\text{SACK}(1)H$ and $\text{DMG}DLYD H$ signals. These signals are ANDed to produce an active low signal. This signal gated with passive $\text{SYNC}H$ and $\text{RPLY}H$ signals to produce the $\text{MCLK}H$ signal, as shown in Figure G-12. $\text{MCLK}H$ clocks the Master flip-flop to the set state; $\text{MASTER}(1)H$ goes high and $\text{MASTER}(0)H$ goes low. $\text{Master}(1)H$ is inverted, producing the active $\text{BREP}L$ signal. $\text{BREP}L$ causes all dynamic MOS memories contained in the system to be simultaneously addressed

during the refresh bus transaction, and it remains active for the duration of the refresh operation. MASTER (0) H, when low, enables the "A" sequence flip-flop; when high, it logically clears the flip-flop.

MASTER (1) H is applied to refresh address logic where it produces the MY ENABLE L signal. This signal enables BDAL bus drivers, and row address bits are placed on the BDAL bus.

The sequence of operations involving the bus control logic is controlled by sequence flip-flops A and B. Operations are synchronized by the positive-going leading edge of the 220 nsec. clock SCLK H signal, as shown in Figure G-11. On the SCLK H leading edge following the active MASTER (1) H signal, the Master-Sync. flip-flop clocks to the set state, producing the active MASTER SYNC (1) H signal. The MASTER SYNC (1) H and B (0) H signals are gated to produce a low signal which clocks sequence flip-flop A to the set state on the following SCLK H pulse. (Note that the typical preset and clear inputs in this circuit are used as clear and preset, respectively, and clocking a low signal into the flip-flop is considered the active or set state in this discussion.) The RPLY (0) H signal is initially high since the refresh bus transaction with system memory has not been completed. Thus, the high RPLY (0) H and A (1) H signals are gated, producing a low signal which keeps the A flip-flop set until the RPLY (0) H signal goes low. The

low A (0) H signal is ORed with B (0) H to produce the PRE SYNC H signal. PRE SYNC H and the active MASTER (1) H signal are gated by the BSYNC L bus driver, causing that bus signal to become asserted.

On the next SCLK H leading edge, the B sequence flip-flop clocks to the set state, producing the high B(1) H and low B(0) H signals. B(1) H and A(1) H are gated by the RDIN L bus driver, causing that signal to become asserted. Bus control logic remains in this state until system memory responds to the refresh transaction by asserting BRPLY L.

BRPLY L is received and inverted, producing RPLY H. On the next leading edge of SCLK H, the reply flip-flop clocks to the set state, and high RPLY (1) H and low RPLY(0) H signals are produced. The low RPLY(0) H signal inhibits the A sequence flip-flop preset gate, and the flip-flop clocks to the reset state on the following SCLK H pulse. A(1) H goes low, inhibiting the RDIN L bus driver, and terminating that signal. RPLY (1) H and B(1) H are ANDed to produce a low signal which presets the B sequence flip-flop. This prevents resetting the B flip-flop as long as RPLY(1) H is in the active state.

System memory responds to the massive RDIN L signal by terminating the BRPLY L signal. On the next SCLK L pulse, the reply flip-flop clocks to the reset state; RPLY(1) H goes low and RPLY(0) H goes

high. The following SCLK L pulse then clocks the B sequence flip-flop to the reset state and B(1) H goes passive; PRE SYNC H and BSYNC L go to the passive states.

Low R PENDING (1) H and DONE (0) H signals are gated to produce the active (low) RCLR L signal (Figure G-10) which clears the Sack flip-flop; RSACK L and RINH (0) H signals go high. RCLR L also clears the Master flip-flop in the bus control logic (Figure G-12), causing RREF L to go passive and MY ENABLE L in the refresh address logic (Figure G-13) to go passive, inhibiting the BDAL bus drivers. On the next SCLK H pulse, MASTER SYNC (1) H goes passive (Figure G-12), and the refresh bus transaction is completed. GRAB RQS H goes passive before the next refresh bus transaction, resetting the Done flip-flop and enabling the next refresh operation.

G.2.4.4 Refresh Address Logic - Refresh address logic is shown in Figure G-13. A six-bit binary counter produces the six row address bits which are placed on the BDAL bus during the addressing portion of the refresh bus transaction. The low MASTER (0) H enables the counter output bits during the operation. Upon completing the transaction, RPLY(1) H goes passive, inhibiting the CK L gate; the CK L signal goes high, incrementing the six-bit binary counter by one count. Hence, on each successive refresh operation, a new row address is used.

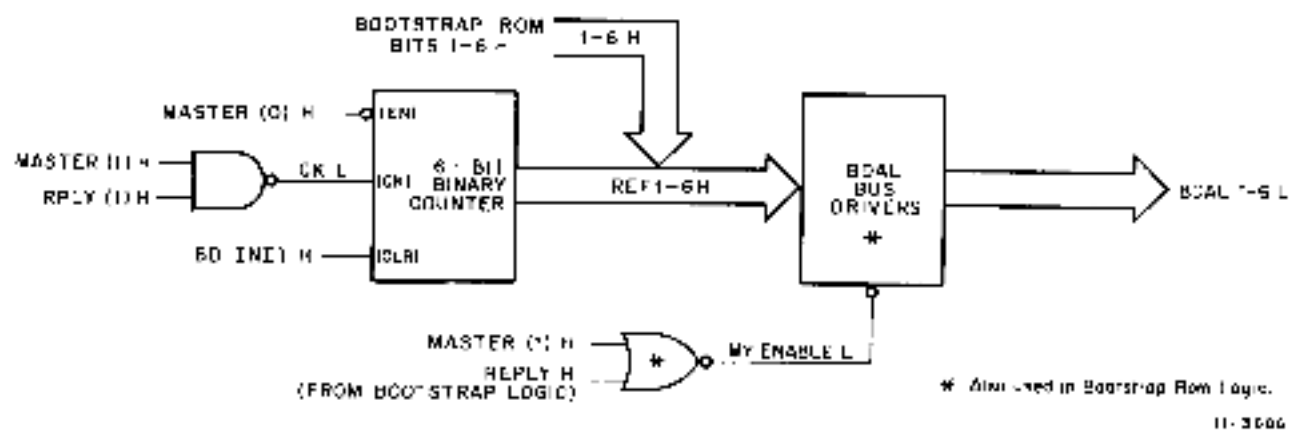

Figure G-13 Refresh Address Logic

C.2.4.5 Initialization - DMA refresh logic initialization is controlled by the EDCOK H signal. Initialization occurs only during power-up or power-down conditions (when EDCOK H is in the low passive state). All flip-flops (except the Done flip-flop) are initialized by either the BD INIT H (inverted-passive EDCOK H), BD INIT L (inverted INIT H), or RCLR L (gated BD INIT H) signals.

G.2 USING LSI-11 BUS ACCESSORY OPTIONS

G.3.1 General

G.3.1.1 DMA Refresh - DMA refresh is provided by the REV11-A, REV11-C, and REV11-E options. When DMA refresh is used, the processor-controlled memory refresh bus cycles should be disabled. This can be accomplished by installing W4 on the wire-wrap posts provided on the processor module. In addition, W2 on the REV11 option (M9400-7A, -7C, or 7E module) must be installed as shown in Figure C-14. Removing W2 disables DMA refresh bus cycles; this is normally done in systems which contain no dynamic MOS memory devices.

When installing the option in the LSI-11 backplane, the REV11 option must have the highest DMA priority if the DMA refresh operation is used. If no other DMA devices are used in the system, the REV11-C can be installed in any option location. However, if any other DMA devices are used in the system, the

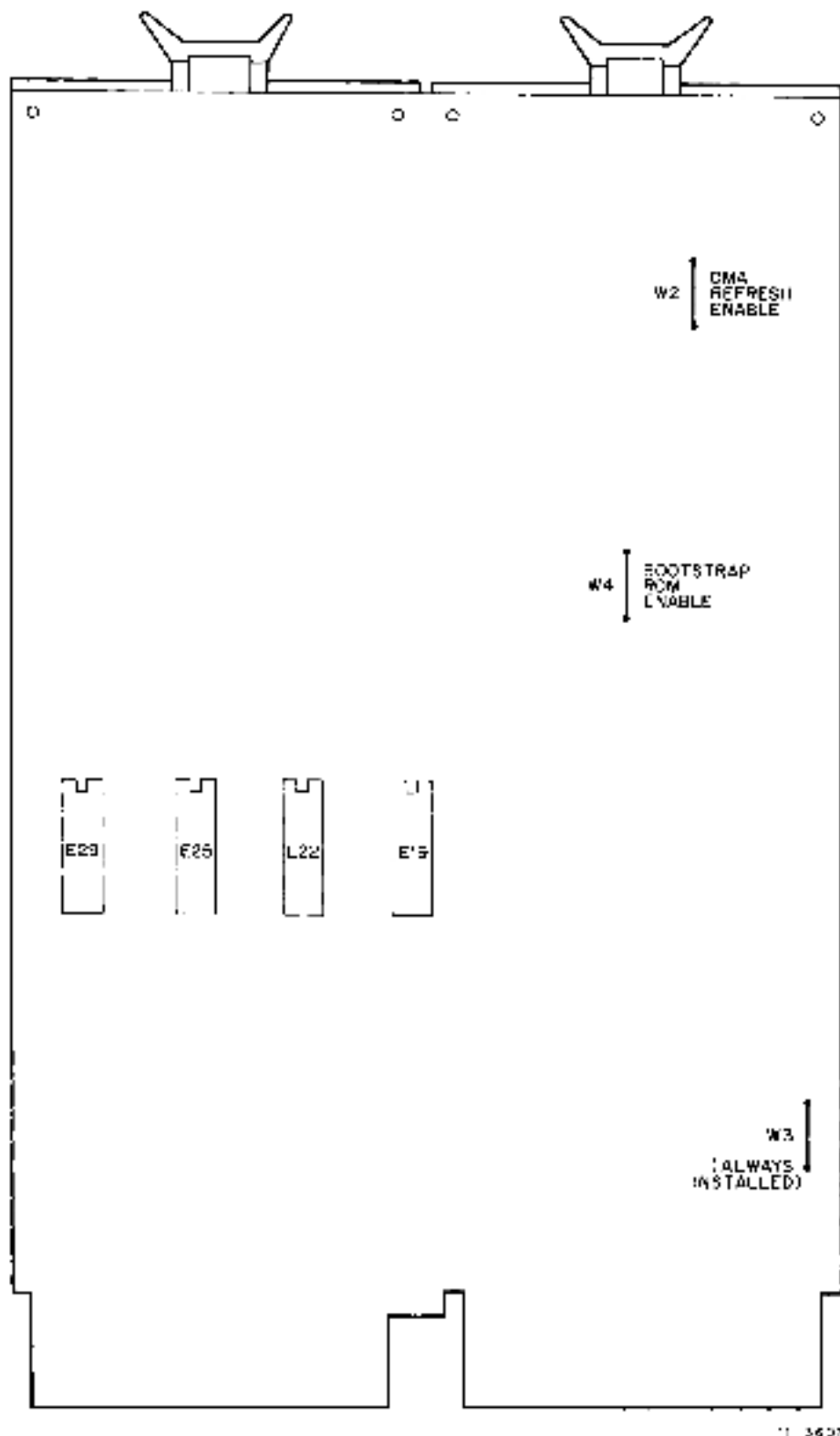

11 3637

Figure G-14 ERV11-A, -C, -II Jumpers

REV11 must be located closest to the processor in order to give it the highest DMA priority; burst (multiple data transaction) operations must not be executed by those DMA devices in order to insure that the DMA refresh cycles occur at timely intervals.

G.3.1.2 ROM Bootstrap - Bootstrap and diagnostic programs are contained in ROM chips contained on REV11-A, REV11-C, and REV11-H options. The ROMs can be accessed only when W4 is installed on the REV11 option (M9400-YA, -YC, or -YH module), as shown in Figure G-14. When W4 is removed, this feature is disabled.

The normal starting address for REV11 ROM programs is 173000. This address can be entered and program operation started either via a console CDD command or automatically during power-up. When automatic entry is desired, processor power up mode 2 must be selected. This mode is selected by installing jumper W6 and removing jumper W5 on the processor module.

REV11-A or REV11-C ROM contents are identical, and their use is described below. The REV11-H contains bootstrap programs for use with Laboratory Data Products (LDP) systems; hence, REV11-H operating instructions are included in appropriate LDP system manuals.

Starting program execution at location 173000 causes execution of a CPU diagnostic program which tests non memory modifying instructions. Successful execution of the diagnostic program is indicated by the console device displaying a dollar sign (\$). This symbol is the prompt character for the user to enter a two or three alphanumeric character command which specifies the desired REV11-A or -C program to be executed.

Unsuccessful execution of the diagnostic program results in the \$ prompt character not being printed. Instead, the failure results in a "branch to self" when a sequence of instructions do not execute properly, or the processor halts due to a double bus error; a halt normally results in the console device displaying the PC contents (the address of the Halt +2), followed by the console ODT prompt character @.

Once the \$ prompt character is displayed, the operator can enter one of the commands described in Table G-2. Note that in the command examples, characters printed by the program are shown underlined; characters not underlined are entered by the operator. Command inputs to the program can either be upper or lower case characters. If an invalid command is entered following the \$ prompt character, the program responds by displaying ? after the

invalid command and a new \$ prompt character on a new line. For example, program response to the invalid "XC" command is shown below:

```

$ XJ ?
$

```

Table G-2
REV11-A and REV11-C ROM Program Commands

Command	Function
CD	<p>ODT (Halt). This allows the operator to examine and/or alter memory and register locations via the console device. Control can be returned to the REV11 program by entering the ODT P (Proceed) command if the PC has not been altered, and the console device will display the \$ prompt character. If the AC has been altered, the operator can start program execution by entering the starting address 165006 and the G (Go) commands as follows:</p> <pre> \$ 165006 \$ </pre> <p>The processor responds by displaying the \$ prompt character on a new line and another REV11 command can be entered.</p>

Command	Function
XMCORV	<p>Memory Diagnostic program. After successfully completing the diagnostic, the prompt character (\$) is displayed on the console device. Errors are indicated by the following displays on the console device:</p> <ol style="list-style-type: none"> 1. <u>173732</u> <u>\$</u> This is an address test error. The expected (normal) data is in R1 and the invalid data is in the memory location pointed to by R2. If desired, continue diagnostic program execution by entering the ODT P command. 2. <u>173756</u> <u>\$</u> This is a data test error. The expected (normal) data is stored in R3 and the invalid data is in the memory location pointed to by R2. If desired, continue diagnostic program execution by entering the ODT P command. 3. <u>000010</u> <u>\$</u> A timeout trap has occurred in testing memory locations outside of the first (lowest) 4K memory.

Command	Function
XC<u>R>	<p data-bbox="487 287 685 329">4. <u>nnnnnn</u></p> <p data-bbox="553 351 586 393"><u>@</u></p> <p data-bbox="553 414 1445 585">A timeout trap has occurred in testing memory locations within the first 4K memory. The nnnnnn displayed is an indeterminate number.</p> <p data-bbox="487 670 1412 1223">The actual memory test consists of an address test and a data test. The address test first writes all memory locations with addresses; it then reads and verifies the addresses. The data test consists of two parts. An "all 1's" word is first walked through all memory locations, which are initially 0. The second part consists of walking an "all 0's" word through all memory locations which are all 1's.</p> <p data-bbox="487 1372 1445 1670">Processor Diagnostic program. This is a memory-modifying instruction test. Successful execution of the diagnostic program results in the prompt character (\$) being displayed on the console device. Errors are indicated by:</p> <ol data-bbox="487 1691 1462 1925" style="list-style-type: none"> <li data-bbox="487 1691 1462 1798">1. The program halts when an instruction sequence is not correctly executed. <li data-bbox="487 1819 1462 1925">2. The program halts in the trap vector area for various traps

Command	Function
	<p style="text-align: center;">NOTE</p> <p>When a halt occurs, the console GDT X command can be used to determine how the halt mode was invoked. When the system fails to successfully execute the above diagnostics, maintenance diagnostic programs should be used to thoroughly test processor (and memory) functions.</p>
AL<CR>	<p>Absolute Loader program, normal (absolute address) loading operation. Entering AL<CR> specifies that a paper tape is to be loaded via the console device (CSR address = 177560). However, another device can be specified by entering the appropriate CSR address. For example, to load paper tapes in absolute loader format via a device whose CSR address is 177550, enter the following command:</p> <p style="text-align: center;">AL177550 <CR></p> <p>The program responds by first executing the memory-modifying CPU instruction test and memory test (refer to the XC and XM commands). Successful test execution results in execution of the Absolute Loader program.</p>

Command	Function
	<p>A successful program load is indicated when:</p> <ol style="list-style-type: none"> The console device displays: <ul style="list-style-type: none"> <u>165526</u> @ The loaded program automatically starts execution. <p>Absolute loader errors are:</p> <ol style="list-style-type: none"> Checksum error, with the program halting and producing the following display: <ul style="list-style-type: none"> <u>165534</u> @ Program halts in the trap vector area for traps other than a timeout trap. Timeout trap occurs, causing the display of \$ on a new line on the console device.
<p>ABCR></p>	<p>Absolute Loader program, relocated loading operation. When this command is entered, the memory-modifying CPU instruction test and memory test are automatically first executed (refer to the XC and XM commands), followed by the Absolute Loader program. Successful execution results in the program halting with the following console display:</p> <ul style="list-style-type: none"> <u>165412</u> @

Command	Function
	<p>The operator must then enter an appropriate "software switch register" number in R4.</p> <p>To select relocated loading which uses an address (bias) contained in the software switch register, enter the following commands:</p> <pre data-bbox="528 595 974 691"> @ R4/<u>xxxxxx</u> nnnnn <CR> @ P </pre> <p>The value nnnnn is a relocation value selected by the operator as directed in the <u>ERP-11 Paper Tape Software User's Handbook</u>. Observe that the least significant "n" value entered must be an odd number; this sets the software switch register (R4) bit 0 to a logical 1, selecting the relocated loading mode. Note that the program being loaded must be in Position Independent Code (PIC) format for relocated loading.</p> <p>When large programs are contained on more than one tape, the program halts at the end of the first tape. Install the second tape in the reader and enter a "1" in R4 using the ODP command shown below; resume loading by entering the P command.</p> <pre data-bbox="528 1755 883 1851"> @ R4/<u>xxxxxx</u> 1 <CR> @ P </pre>

Command	Function
	<p>The six octal digits (xxxxxx) are the present contents of R4. Entering a value of 1 selects relocated loading for the next program tape, starting at the address following the end of the previous load operation. The P command allows the absolute loader program execution to continue the loading process once the software switch register value has been entered.</p> <p>A successful program load is indicated when:</p> <ol style="list-style-type: none"> 1. The console device displays <ul style="list-style-type: none"> <u>165626</u> <u>@</u> 2. The loaded program automatically starts execution. <p>Absolute loader errors are as described for the AL command.</p> <p>DX <CR> or DXn <CR></p> <p>RXV1 floppy disk system bootstrap. Entering the DX <CR> command starts the memory-modifying CPU instruction test and memory test execution (see the XC and XM commands). Successful test execution results in execution of the bootstrap program for disk drive 0, the System disk. Otherwise, specify the drive number (n) as 0 (drive 0) or 1 (drive 1).</p>

Command	Function
	<p>Floppy disk bootstrap errors are:</p> <ol style="list-style-type: none"> 1. The program halts and the console device displays: <p><u>165316</u></p> <p>@</p> <p>indicating that the device Done flag in the RXV11 interface was not set within the required time (approx. 1.3 sec.). The bootstrap can be restarted by entering the P command; the \$ is then displayed on the console device and the bootstrap command can be entered.</p> 2. The program halts and the console displays: <p><u>165644</u></p> <p>@</p> <p>indicating that a bootstrap error occurred. The RXV11's Error Register contents are stored in R2. By examining the contents of R2 and using the information contained in the <u>RXV11 User's Manual</u>, the exact nature of the error can be determined. Examine the contents of R2 (nnnnnn) as follows:</p> <p>@ R2/<u>nnnnnn</u> <CR></p> <p>@ P</p> <p>\$</p>

Command	Function
	<p>After examining R2, the bootstrap can be re started by the P command; enter the desired bootstrap command immediately after the \$ prompt character.</p> <p>3. The program halts in the trap vector for traps; a timeout trap returns the program to the \$ prompt character. Attempt to successfully bootstrap the system by again entering the desired bootstrap command.</p>

Bootstrap programs can be started from the Halt (console ODT) mode (refer to the OD command) without first executing the Diagnostic programs. Programs started in this manner include the absolute Loaders (AL and AR) and the bootstrap for disk drive 0 (DX).

Start the DX bootstrap program by first loading R4 with the DX bootstrap starting address (165264). Start the REV11 program at 165242. This sequence of operations is shown below:

```

$ OD
$ R4/xxxxxx 165264 <CR>
$ 165242G

```

Start the absolute loader program (AL or AR) by loading the appropriate starting address in R4:

AL starting address = 165414

AR starting address = 165406

Load the highest available memory address in R5. For example, if the system contains 4K read/write memory, load R5 with 177776. Proceed loading by starting the REV11 program at 165242. The complete sequence for starting the AL program in a 4K system is shown below:

```
Ⓢ OD
Ⓜ R4/xxxxxxx 165414 <CR>
Ⓜ R5/xxxxxxx 177776 <CR>
Ⓢ 165242 G
```

G.3.1.3 Bus Terminations - Bus terminations are included on REV11-A, BCV1B (M9400-YB module), and TEV11 options. The BCV1B includes a 250Ω bus terminator/cable connector which is installed on the first backplane when expanding to a second backplane. REV11-A and TEV11 options include 120Ω bus terminations. Either the TEV11 or REV11-A must be installed in the last available option slot in the last (second or third) backplane in a two or three backplane system. The REV11-A option should not be used in systems which include other DMA devices, unless the REV11's DMA refresh is disabled and either the processor module refresh operation is enabled or refresh operation is not required.

CAUTION

The use of other DMA devices which are installed on the I/O bus between the REV11-A and the processor module will likely result in ineffective DMA refresh and loss of memory data. When DMA devices are to be used in addition to the REV11 option, use the REV11-C (no termination resistors) and the TBV11; install the REV11-C as the highest priority DMA device and the TBV11 as the 120A bus termination in the last option location.

G.3.2 Using the REV11-A

G.3.2.1 Installation - The REV11-A is normally factory-installed in a system backplane as part of a complete system. However, if the module is removed for service or system modifications, it must be properly installed to insure proper system operation. Items to be considered when installing the REV11-A are:

1. Jumpers (M9400-VA and processor module).
2. ROM chip placement
3. Module location on backplane

Jumpers - Three jumpers are normally installed on the M9400-YA module, as shown in Figure G-14. Jumpers W2 and/or W4 can be removed to alter REV11-A operation as follows:

	<u>Normal</u>	<u>Altered</u>
<u>Jumper</u>	<u>{Installed} Function</u>	<u>{Removed} Function</u>
W2	DMA refresh enabled	DMA refresh disabled
W4	Bootstrap ROM enabled	Bootstrap ROM disabled

ROM Chip Placement - ROM chips are factory-installed in sockets and should not be removed. ROM chip socket locations E19, E22, E25, and E29 are shown in Figure G-14. ROM chips, whose part numbers are listed below, must be installed only in the sockets listed:

<u>ROM Part No.</u>	<u>Socket</u>
23-074A9-00	E19
23-075A9-00	E22
23-076A9-00	E25
23-077A9-00	E29

Module Location On Backplane - The REV11-A is used in two or three backplane configurations which require a 120 Ω bus termination in the last option location on the I/O bus. The REV11-A must not be used in system applications which use other DMA devices on the I/O bus, since those devices would have higher priority. Do not allow any option locations between the M9400-YA module and the processor module to remain unoccupied; option locations must be

occupied in order to pass the processor's daisy-chained BDMGT/O L signal to the M9400-YA module. Hence, the module should be located in the last available option location on the last (second or third) backplane.

G.3.2.2 Operation - Bootstrap ROM programs included in this option are used as described in paragraph G.3.1.2.

G.3.3 Using the REV11-C

The REV11-C is identical to the REV11-A except the bus termination function is not included. This option should be installed as the first (highest-priority) DMA device in the system. As supplied from the factory, the bootstrap ROM and DMA refresh functions are implemented. If desired, one of the functions can be disabled by removing a jumper, as directed for the REV11-A option (para. G.3.2.1). Bootstrap ROM programs included in this option are used as described in para. G.3.1.2.

G.3.4 Using the REV11-H

The REV11-H is identical to the REV11-C except the ROM bootstrap programs are different. Install the module as directed in para. G.3.3. Refer to LDP system manuals for hardware in which the REV11-H is installed for detailed operating procedures.

G.3.5 Using the TEV11

The TEV11 is a 120Ω terminator module which is used in LSI-11

multiple backplane assemblies. Install the TEV11 in the last available location in the last (second or third) backplane.

G.3.6 Using the BCV1B

The BCV1B option includes two BC05L cables, one M9400-YE module and one M9401 module. This option is always used for connecting the first backplane to a second backplane in multiple backplane systems.

Install the M9400-YE module in the last option location in the first backplane, slots A4, B4. Insure that all option slots in the first backplane are occupied. This is necessary to insure that delay-chained BIAK and BDMG signals will be applied to the last option in the backplane (the M9400-YE module). Install the M9401 module in the first option slot (A1, B1) of the second backplane. Install the two BC05L cables between the M9400-YE and M9401 modules. Note that J1 on each module are connected by the same cable; similarly, J2 on each module are connected by the second cable.

The completed installation for a two backplane system using the BCV1B option is shown in Figure G-15. A 120Ω bus termination is required in the last option slot in the second backplane in a two backplane configuration. This function is normally provided by the TEV11 option, previously described.

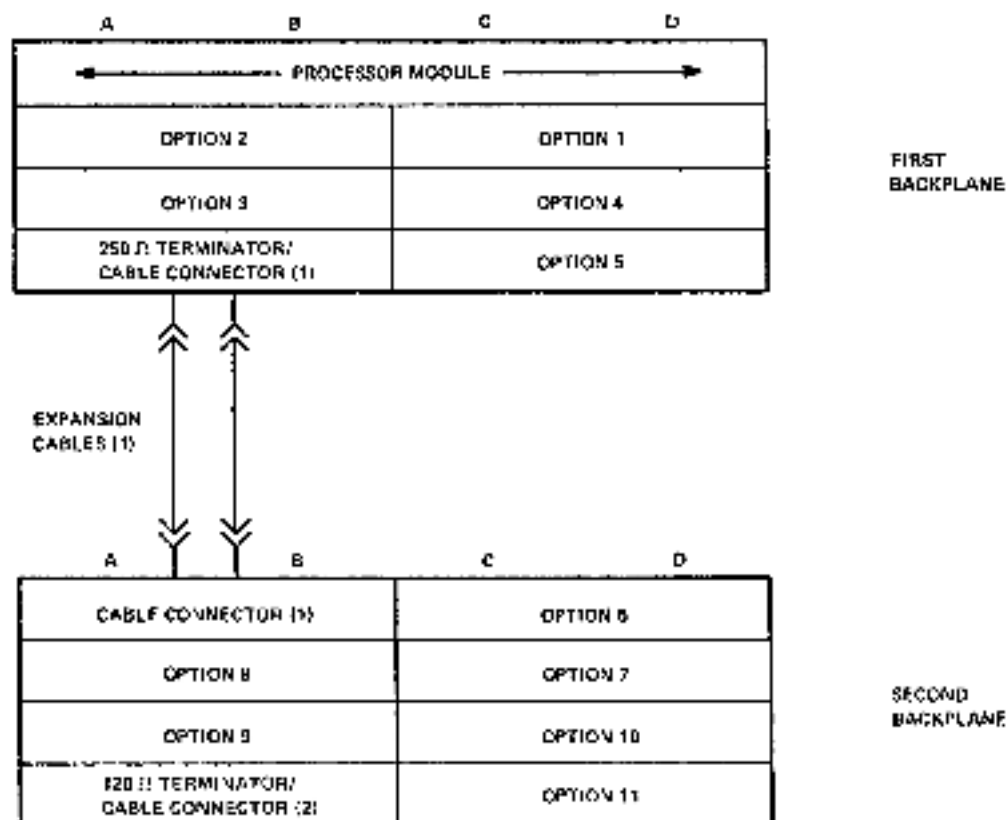

Notes:

1. Included in BCV1B bus expansion option. (Cables are available in 2, 4, 6, or 12 ft. lengths.)
2. Included in TEV11 bus terminator option.

GP-2047

Figure G-15 BCV1B Installation

G.3.7 Using the BCV1A

The BCV1A option includes two BC05L cables, one M9400-YD module, and one M9401 module. This option is always used for connecting the second backplane to the third backplane in three backplane systems.

Install the M9400-YD module in the last option location in the second backplane, slots A4, B4. Observe that all option slots in

the first and second backplanes are occupied. This is necessary to insure that daisy-chained BIAK and BDXG signals will be applied to the last option slot in the second backplane, in which the M9400-YD is installed. Install the M9401 module in the first option slot (A1, B1) in the third backplane. Install the two BC051 cables between the M9400-YD and M9401 modules. J1 on each module are connected by the same cable. Similarly, J2 on each module are connected by the second cable.

The completed installation for a three backplane system using the BCV1A option is shown in Figure G-16. In addition to this option, the BCV1B option is required for connecting the first backplane to the second backplane, and a 120Ω bus termination is required in the last option slot in the third backplane. The 120Ω bus termination function is normally provided by the TEV11 option, as previously described.

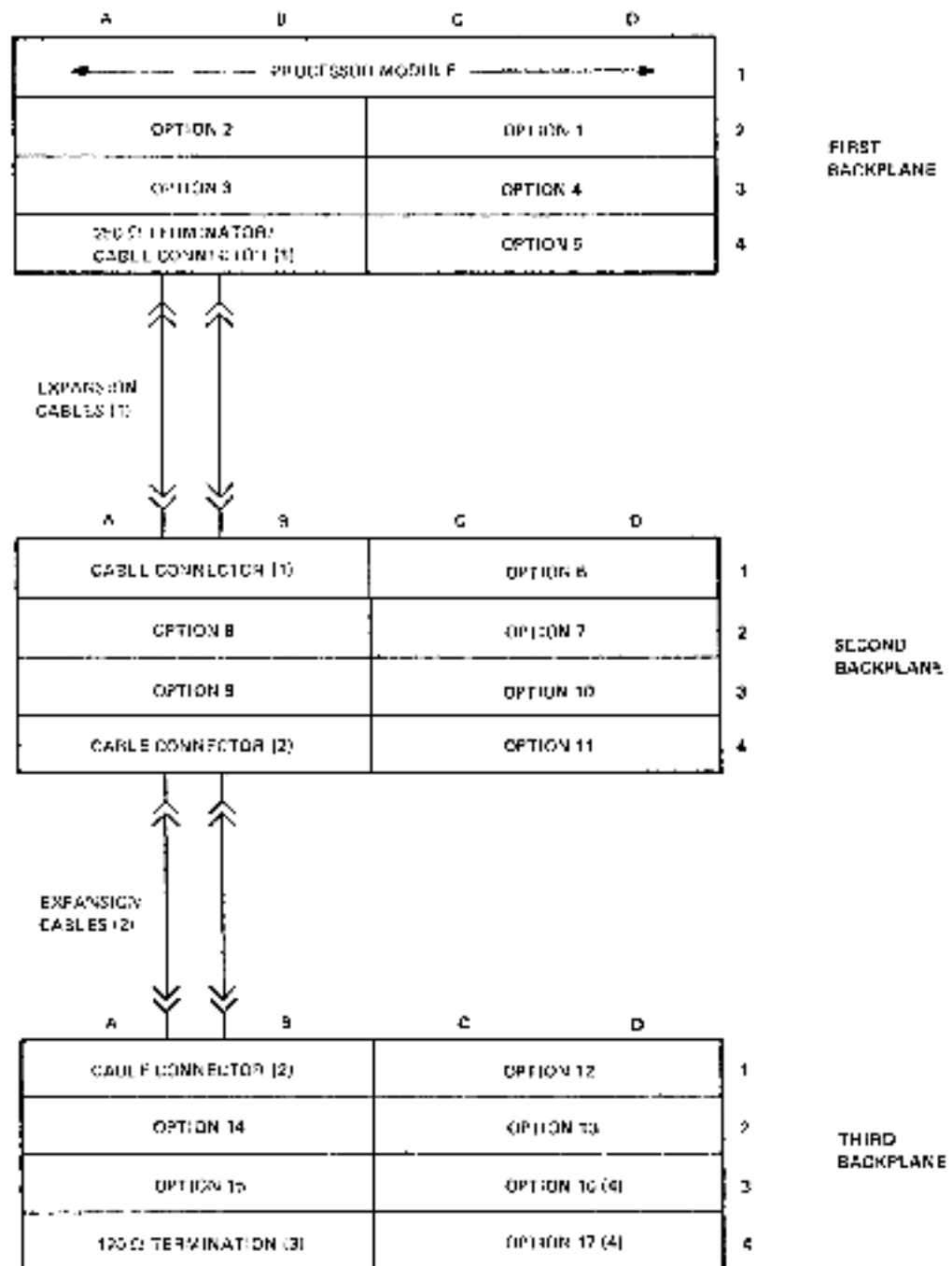

Notes:

1. Included in BCV1B bus expansion option. (Cables are available in 2, 4, 8, or 12 ft. lengths.)
2. Included in BCV1A bus expansion option. (Cables are available in 2, 4, 8, or 12 ft. lengths.)
3. Included in TEV11 bus terminator option.
4. The CS11 Bus is restricted to 15 options, maximum. These option slots would only be used when previous option(s) occupy more than 1 option location.

Figure G-16 BCV1A Installation

GP-2048

APPENDIX H DLV11 I/O JUMPER CONFIGURATIONS

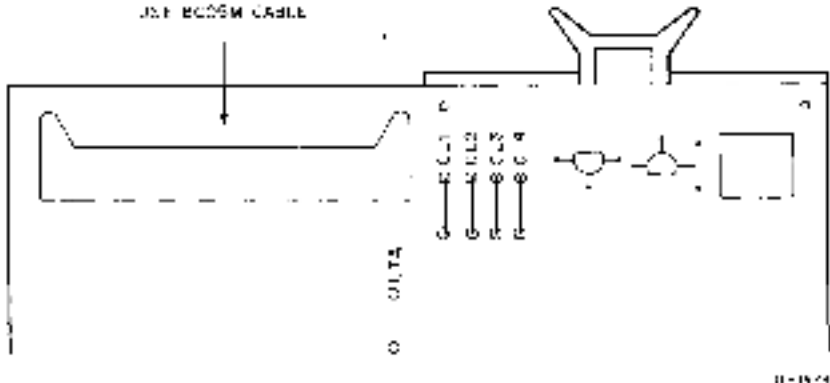

Figure H-1 20 mA Active Current Loop Interface

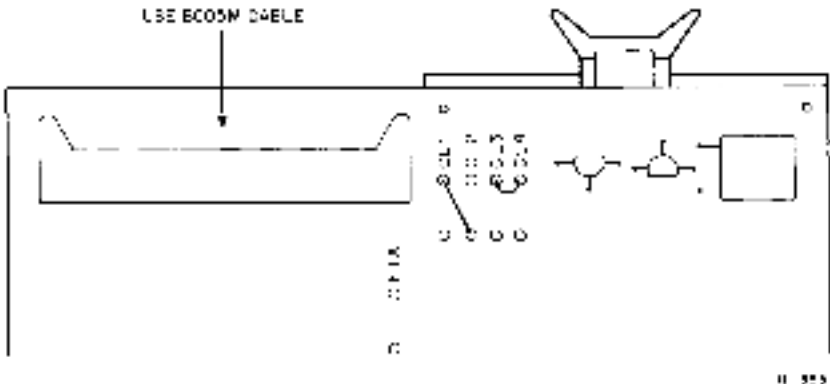

Figure H-2 20 mA Passive Current Loop Interface

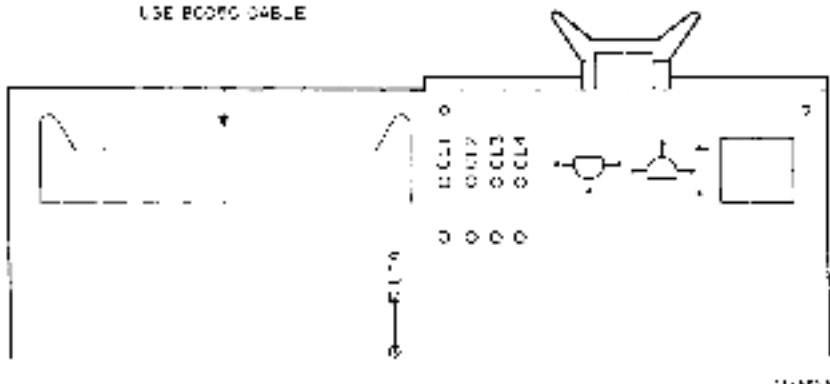

Figure H-3 EIA Interface

Reader's Comments

LSI-11, PDP-11/03 User's Manual
EK LSI11-TM-003

Your comments and suggestions will help us in our continuous effort to improve the quality and usefulness of our publications.

What is your general reaction to this manual? In your judgment is it complete, accurate, well organized, well written, etc.? Is it easy to use? _____

What features are most useful? _____

What faults do you find with the manual? _____

Does this manual satisfy the need you think it was intended to satisfy? _____
Does it satisfy *your* needs? _____ Why? _____

Would you please indicate any factual errors you have found. _____

Please describe your position. _____
Name _____ Organization _____
Street _____ Department _____
City _____ State _____ Zip or Country _____

RED LINE
CUT OUT ON

Fold Here

Do Not Tear - Fold Here and Staple

FIRST CLASS
PERMIT NO 33
MAYNARD, MASS.

BUSINESS REPLY MAIL
NO POSTAGE STAMP NECESSARY IF MAILED IN THE UNITED STATES

Postage will be paid by:

Digital Equipment Corporation
Technical Documentation Department
146 Main Street
Maynard, Massachusetts 01754



