

# DEClaser 3200/3250

---

## Service Guide

EK-LN08Z-SV-001

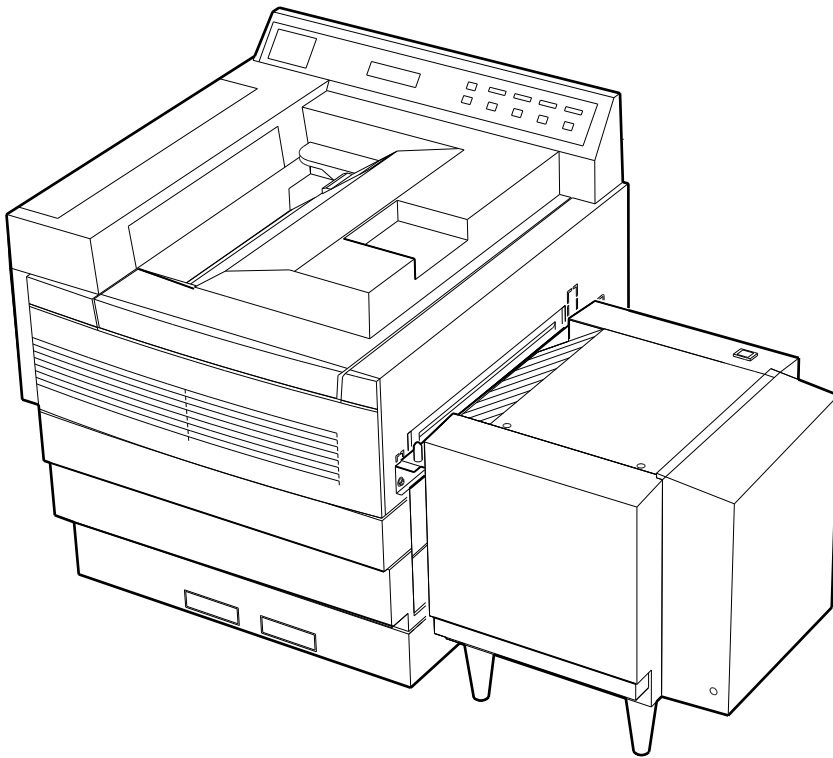

**Digital Equipment Corporation**  
**Maynard, Massachusetts**

---

**December 1991**

The information in this document is subject to change without notice and should not be construed as a commitment by Digital Equipment Corporation.

Digital Equipment Corporation assumes no responsibility for any errors that may appear in this document.

Any software described in this document is furnished under a license and may be used or copied only in accordance with the license. No responsibility is assumed for the use or reliability of software or equipment that is not supplied by Digital Equipment Corporation or its affiliated companies.

Restricted Rights: Use, duplication, or disclosure by the U.S. Government is subject to restrictions as set forth in subparagraph (c)(1)(ii) of the Rights in Technical Data and Computer Software clause at DFARS 252.227-7013.

© Digital Equipment Corporation 1991.  
All rights reserved. Printed in U.S.A.

DECdirect, DEClaser, PrintServer, ReGIS, VAX DOCUMENT, and the DIGITAL Logo are trademarks of Digital Equipment Corporation.

BITSTREAM is a registered trademark of Bitstream, Inc., Centronics is a trademark of Centronics Data Corporation, GC Times is a trademark of AGFA Compugraphic Corporation, CG Triumvirate is a trademark of AGFA Compugraphic Corporation, IBM is a registered trademark of International Business Machines Corporation, IBM-PC is a trademark of International Business Machines Corporation, ITC Souvenir is a registered trademark of International Typeface Corporation, PCL and LaserJet are registered trademarks of the Hewlett-Packard Company, Microsoft is a registered trademark of Microsoft Corporation, WordPerfect is a registered trademark of WordPerfect Corporation, PostScript is a registered trademark of Adobe Systems, Inc., and Tektronix is a registered trademark of Tektronix, Inc.

The Reader's Comments form at the end of this document requests your critical evaluation to assist in preparing future documentation.

S1589

This document was prepared with VAX DOCUMENT, Version 1.2.

---

# Contents

<b>Preface</b> .....	xv
<b>About This Service Guide</b> .....	xvii
<b>1 Physical and Functional Description</b>	
1.1 Safety Warnings .....	1-1
1.2 External Description .....	1-2
1.3 Cassette Feeders .....	1-7
1.3.1 Loading Cassettes .....	1-8
1.3.2 Adjustable Cassette .....	1-10
1.3.2.1 A and B Cassettes .....	1-12
1.3.3 Cassette Size-sensing .....	1-12
1.4 Optional Equipment .....	1-14
<b>2 Control Panel Operations and Menus</b>	
2.1 Control Panel Keys and Indicators .....	2-1
2.2 Operational Display Format .....	2-5
2.2.1 Operational Status Messages .....	2-6
2.3 About the Customer and Service Menus .....	2-7
2.3.1 Customer Menus .....	2-8
2.3.2 Set Up Memory Organization .....	2-8
2.3.3 Changing and Selecting Values or Defaults .....	2-9
2.4 Set Up Menus .....	2-9
2.4.1 PROTOCOL .....	2-11
2.4.2 ADJ CASSETTE .....	2-11
2.4.3 ALARM .....	2-12
2.4.4 COMM INTERFACE .....	2-13
2.4.5 DISPLAY LANGUAGE .....	2-14
2.4.6 COMM ERROR .....	2-14
2.5 Defaults Menu .....	2-15

2.6	Test Menu .....	2-16
2.6.1	Configuration Sheet .....	2-16
2.6.2	Font Status Sheet .....	2-18
2.6.3	Control Representation (CR) Mode.....	2-18

### 3 Service Menus and Tests

3.1	1701 Special Function and Test Codes .....	3-1
3.1.1	Starting, Stopping, and Running 1701 Menu and Codes .....	3-2
3.1.2	1701 Special Function Codes .....	3-3
3.1.3	1701 Diagnostic Tests.....	3-5
3.2	1948 Service Menu.....	3-8
3.3	Test Print Menu .....	3-12
3.3.1	Grid and Dusting Test Prints .....	3-14
3.4	Service Shutdown and Power-Up Procedure .....	3-14

### 4 Start FIP and Nonerror Code FIPs

4.1	Start FIP .....	4-2
4.2	Noises .....	4-3
4.3	Fuser Fan .....	4-5
4.4	Blank, Silent, and Inoperative Control Panel FIP .....	4-6
4.5	Erratic Operation .....	4-7
4.5.1	Bad Grounds .....	4-8
4.5.2	Line Power or LVPSA Problems .....	4-8
4.5.3	High-Voltage Arcing .....	4-9

### 5 Display Error Code FIPs

5.1	Error Code FIPs and Messages .....	5-2
5.2	103, Close Top Cover .....	5-6
5.3	104, Close Left Cover (Exit Door) .....	5-7
5.4	105, Close Right Cover (Feed Door) .....	5-9
5.5	0300-0302 CALL SERVICE .....	5-10
5.6	0305 CALL SERVICE .....	5-10
5.7	0312-0313 CALL SERVICE .....	5-13
5.8	0401 CALL SERVICE .....	5-14
5.9	0600/0601 CALL SERVICE .....	5-15
5.10	0700 ADD PAPER TO MANUAL .....	5-17
5.11	0701 ADD PAPER TO TRAY 1 .....	5-18
5.12	0702 ADD PAPER TO TRAY 2 .....	5-19
5.13	0703 ADD PAPER TO FEEDER .....	5-20
5.14	0705 INSERT TRAY 1 .....	5-21

5.15	0706 INSERT TRAY 2	5-22
5.16	0707 INSERT AUXILIARY	5-23
5.17	0901-0904 CARTRIDGE A	5-24
5.18	0911-0914 CARTRIDGE C	5-25
5.19	0921-0924 CARTRIDGE B	5-26
5.20	1001-1005 CALL SERVICE	5-28
5.21	1111 EMPTY THE OUTPUT TRAY	5-30
5.22	1120 NO OFFSET	5-32
5.23	1400-1407 COMM ERROR PRESS Defaults	5-34
5.24	1500 REPLACE CARTRIDGE 1/2	5-34
5.25	1502-1503 REPLACE MEMORY BD_1/2/3/4/5	5-35
5.26	1508 BAD COPROCESSOR	5-36
5.27	1509 REPLACE NVM	5-37
5.28	1520 CALL SERVICE	5-37
5.29	1521-1523 REPLACE/ADD PDL BD/MEMORY	5-37
5.30	1526 CALL SERVICE	5-37

## 6 Paper Path Jam FIPs

6.1	Jams and Paper Misfeeding	6-2
6.2	0820-0824 CLEAR PAPER PATH	6-4
6.2.1	Registration Transport Diagram and Tests	6-6
6.2.2	0820 Paper Under the BYPASS Sensor	6-8
6.2.3	0821 Upper Cassette Feed Failure	6-9
6.2.4	0822 Lower Cassette Feed Failure	6-10
6.2.5	0823 LCIT Feed Failure	6-13
6.2.6	0824 Duplex Refeed Failure	6-15
6.3	0826 CLEAR PAPER PATH	6-16
6.4	0827 CLEAR PAPER PATH	6-18
6.5	0830-0834 CLEAR PAPER PATH	6-20
6.5.1	Tests and Wiring Diagram	6-22
6.5.2	0830 Manual Feeding	6-24
6.5.3	0831 Upper Cassette	6-25
6.5.4	0832 Lower Cassette	6-26
6.5.5	0833 LCIT Feeding	6-26
6.5.6	0834 Duplex Refeed	6-27
6.6	1020-1024 CLEAR PAPER PATH	6-28
6.7	1025 CLEAR PAPER PATH	6-33
6.8	1026 CLEAR PAPER PATH	6-35

## 7 Image Defects FIPs

7.1	Image Defect Lookup	7-2
7.2	Background Staining	7-3
7.3	Black Prints	7-5
7.4	Blank Prints	7-5
7.5	Damaged Prints	7-7
7.6	Deletions, Blank, or White Spots	7-8
7.6.1	Vertical Deletions or White Bands	7-8
7.6.2	Horizontal Deletions or White Bands	7-9
7.6.3	Random or Localized White Spots	7-10
7.7	Extraneous Marks	7-10
7.8	Light Images	7-11
7.9	Misregistration	7-12
7.10	Skewed Image	7-14
7.11	Residual Image	7-16
7.12	Black Spots	7-16
7.13	Fusing Failure	7-17
7.14	Black Lines or Streaks	7-18
7.15	HVPSA FIP	7-19
7.16	Erase FIP	7-20
7.17	Developer Bias FIP	7-21

## 8 RSL and Parts Location

8.1	Recommended Spares List	8-1
8.1.1	LCIT Recommended Spares List	8-4
8.2	Parts Locator	8-6

## 9 Removal and Replacement Procedures

9.1	General	9-1
9.2	Top Door Cover	9-2
9.3	Upper Cover	9-3
9.4	Rear Panel	9-6
9.5	Lower Front Cover	9-10
9.6	Right Side Cover	9-11
9.7	Right Cover (Feed Door)	9-12
9.8	Left Cover (Exit Door)	9-14
9.9	Large Capacity Input Tray (LCIT) and Mounting Plate	9-15
9.10	Assembly Separation	9-17
9.11	Photoreceptor (Print) Drum	9-21
9.12	Developer Unit	9-22

9.12.1	Installing a new developer unit .....	9-23
9.13	Toner Cartridges .....	9-24
9.14	Video Control Board .....	9-25
9.14.1	PostScript Description Language Option (PDL) Board .....	9-27
9.14.2	Coprocessor SIM .....	9-28
9.14.3	Expansion Memory (SIM) .....	9-30
9.15	DC Control Board .....	9-34
9.15.1	DC Control Board Harness .....	9-38
9.15.2	Page Count Memory .....	9-39
9.16	LVPSA .....	9-40
9.17	HVPSA .....	9-43
9.17.1	Primary High-Voltage Connector .....	9-45
9.17.2	Print Drum Ground Clips .....	9-46
9.17.3	Developer Bias Connector .....	9-47
9.18	Drive Board .....	9-48
9.19	Rear Electronics Assembly .....	9-49
9.20	Video Cooling Fan .....	9-54
9.21	Developer Interconnect Board .....	9-56
9.22	Upper Bracket .....	9-57
9.22.1	Fuser Fan .....	9-59
9.22.2	Control Panel .....	9-60
9.23	Laser/Scanner Assembly .....	9-61
9.24	Top Door (Scanner) Interlock Sensor .....	9-64
9.25	Transfer/Separation Charger .....	9-65
9.26	Erase Board .....	9-66
9.27	Registration Transport Assembly .....	9-68
9.28	Fusing Unit .....	9-70
9.28.1	Fuser Cleaning Pad .....	9-73
9.29	Prefuser Transport .....	9-74
9.30	Lower Postfuser Transport .....	9-75
9.30.1	Upper Postfuser Transport Assembly .....	9-76
9.31	Gate Sensor Linkage .....	9-77
9.32	Refeed Cover .....	9-78
9.33	Refeed Rollers and Clutch .....	9-80
9.34	Exit Motor .....	9-86
9.35	Offset Motor Assembly .....	9-87
9.36	Main Motor .....	9-90
9.37	Upper Cassette-empty Sensor .....	9-93
9.38	Upper Size-sensing Assembly .....	9-94
9.39	Lower Cassette-empty Sensor .....	9-96
9.40	Lower Size-sensing Assembly .....	9-97
9.41	Bypass Sensor .....	9-98
9.42	Exit Sensor .....	9-99

9.43	Refeed Sensor .....	9-100
9.44	Feed-Door Sensor .....	9-102
9.45	Exit-Door Sensor .....	9-103
9.46	Registration Sensor .....	9-104
9.47	Tray-full Sensor .....	9-105
9.48	Exit Pinch Roller .....	9-106
9.49	Exit Drive Roller .....	9-111
9.50	Upper Feed Roller/Clutch .....	9-114
9.51	Upper Feed Solenoid .....	9-118
9.52	Lower Feed Roller/Clutch and Solenoid .....	9-120
9.53	Lower Turn Drive Roller and Clutch .....	9-123

## 10 Adjustments and Cleaning Procedures

10.1	Setting Auto Scan .....	10-1
10.2	Setting Power Saver Time .....	10-2
10.3	Horizontal Registration Adjustment .....	10-3
10.4	Vertical Registration Adjustment .....	10-4
10.5	Feed Roller Cleaning Procedure .....	10-5
10.6	Transfer/Separation Charger Cleaning Procedure .....	10-7

## 11 Large Capacity Input Tray (LCIT)

11.1	LCIT Physical and Functional Description .....	11-2
11.2	LCIT FIPs .....	11-7
11.2.1	Error Code LCIT FIPS .....	11-10
11.3	Tray Parallelism Adjustment .....	11-10
11.4	LCIT Removal and Replacement Procedures .....	11-11
11.4.1	Top Cover .....	11-12
11.4.2	Front Cover .....	11-13
11.4.3	Rear Cover .....	11-15
11.4.4	Elevator Motor .....	11-17
11.4.5	Feed Motor .....	11-19
11.4.6	Control Board and Size Jumper .....	11-20
11.4.7	Paper-Out Sensor (Switch) .....	11-22
11.4.8	Lower Limit Switch .....	11-23
11.4.9	Upper Limit Switch .....	11-24
11.4.10	Door Switch .....	11-25
11.4.11	Paper Feed Rollers .....	11-26

## A Supplemental Information

A.1	Interface Interconnections . . . . .	A-1
A.1.1	Parallel Port . . . . .	A-1
A.1.2	Serial Port . . . . .	A-4
A.2	Interface Cables and Adapters . . . . .	A-4
A.3	Accessories and Supplies . . . . .	A-6
A.4	Connector Locations . . . . .	A-8
A.5	DC Power Distribution . . . . .	A-9

## B DEClaser 3200 Specifications

B.1	Paper Handling and Storage . . . . .	B-1
B.2	Print Media . . . . .	B-2
B.2.1	Paper for Cassette Feeding . . . . .	B-2
B.2.1.1	Special Considerations When Printing on Paper . . . . .	B-3
B.2.2	Envelope Specifications . . . . .	B-3
B.2.2.1	Special Considerations When Printing on Envelopes . . . . .	B-4
B.2.3	Transparency Specifications . . . . .	B-4
B.2.3.1	Special Considerations When Printing on Transparencies . . . . .	B-5
B.2.4	Label Specifications . . . . .	B-5
B.2.4.1	Special Considerations When Printing on Labels . . . . .	B-6
B.3	Operating Specifications . . . . .	B-6

## C DEClaser 3200 Total Call Concept (TCC)

C.1	About TCC . . . . .	C-2
C.2	Cleaning and Inspection . . . . .	C-2
C.3	Tests and Checks . . . . .	C-3
C.4	Final Test . . . . .	C-3
C.5	Maintenance Log . . . . .	C-4

## D DEClaser 3200 Training, Tools, and Documentation

D.1	Training . . . . .	D-1
D.2	Tools . . . . .	D-2
D.3	Documentation Ordering Information . . . . .	D-3

## E Resident Protocols

E.1	DEC PPL3 Submenu .....	E-1
E.1.1	TRAY SELECTION .....	E-3
E.1.2	DUPLEX .....	E-3
E.1.3	MEMORY MANAGEMENT .....	E-4
E.1.4	AUTO WRAP .....	E-5
E.1.5	NEW LINE .....	E-5
E.1.6	USER PREF SET .....	E-6
E.1.7	DEVICE ID .....	E-6
E.1.8	POWER-UP MESSAGE .....	E-7
E.2	LJ2D Submenu .....	E-8
E.2.1	COPIES .....	E-10
E.2.2	TRAY SELECTION .....	E-10
E.2.3	DUPLEX .....	E-10
E.2.4	FONT NUMBER .....	E-11
E.2.5	PAPER SIZE .....	E-11
E.2.6	ORIENTATION .....	E-12
E.2.7	FORM LENGTH .....	E-12
E.2.8	SYMBOL SET .....	E-13
E.3	PostScript Submenu .....	E-14
E.3.1	DUPLEX .....	E-16
E.3.2	TUMBLE .....	E-16
E.3.3	PAPER TRAY .....	E-17
E.3.4	TRAY SWITCHING .....	E-17
E.3.5	TRAY SWITCH SEQ .....	E-18
E.3.6	MAN/MMF SIZE .....	E-19
E.3.7	OUTPUT OFFSET .....	E-19
E.3.8	WAIT TIMEOUT .....	E-20
E.3.9	START PAGE .....	E-20
E.3.10	JAM RECOVERY .....	E-21
E.3.11	ALLOW JOB RESET .....	E-21
E.3.12	ASYN CTRL MODE .....	E-22

## Index

## Figures

1-1	Printer Components: Front View .....	1-2
1-2	Printer Components: Rear View .....	1-4
1-3	Printer Components: Inside View .....	1-6
1-4	MAX Limit and Snubbers .....	1-9
1-5	Adjustable Cassette .....	1-11
1-6	Adjustable Size-sensing .....	1-12
1-7	Tray 1 Size-sensing Magnets .....	1-13
2-1	Control Panel .....	2-2
2-2	Printer Status Display .....	2-5
2-3	Set Up Memory Organization .....	2-8
2-4	Set Up Menu Diagram .....	2-10
2-5	Configuration Sheet .....	2-17
2-6	Font Status List .....	2-19
3-1	1948 Service Menu SETUP PATTERN .....	3-10
3-2	Error Log .....	3-11
3-3	Test Print Menu .....	3-12
3-4	Test Menu Patterns .....	3-14
4-1	Overall Troubleshooting Flow .....	4-1
4-2	Connectors .....	4-7
5-1	Overall Troubleshooting Flow .....	5-1
5-2	Error Message and Code Display .....	5-2
5-3	103 Error Code .....	5-7
5-4	104 Error Code .....	5-8
5-5	105 Error Code .....	5-10
5-6	Rear Error LED .....	5-11
5-7	DC control board ICs .....	5-13
5-8	Main Motor Location .....	5-15
5-9	Scanner Circuit .....	5-16
5-10	700 Error .....	5-17
5-11	701 Error .....	5-18
5-12	702 Error .....	5-19
5-13	Upper and Lower Size-sensing Switches .....	5-22
5-14	707 Error .....	5-24
5-15	Fuser Circuit and Connectors .....	5-28
5-16	Tray Full Sensor Linkage .....	5-31

5-17	Offset Motor . . . . .	5-33
5-18	1502-1503 Errors (Memory SIMs) . . . . .	5-35
5-19	1508-1521 Errors . . . . .	5-36
6-1	Overall Troubleshooting Flow . . . . .	6-1
6-2	Paper Path Jam Areas . . . . .	6-2
6-3	Registration Jam Path . . . . .	6-5
6-4	Registration Sensor and Upper Turn Clutch . . . . .	6-7
6-5	Bypass Sensor Diagram . . . . .	6-9
6-6	Upper Feed Solenoid Diagram . . . . .	6-10
6-7	Lower Feed Solenoid Spacer . . . . .	6-11
6-8	Lower Feed Solenoid and Turn Clutch . . . . .	6-12
6-9	LCIT Paper Feed Connectors . . . . .	6-14
6-10	Refeed Leading Edge Jam . . . . .	6-16
6-11	Refeed Sensor and Clutch . . . . .	6-18
6-12	Refeed Trailing Edge Jam . . . . .	6-19
6-13	Registration or Shingle Jams . . . . .	6-21
6-14	Registration Sensor and Clutch . . . . .	6-23
6-15	Cassette Magnets . . . . .	6-25
6-16	Gate Area Jams . . . . .	6-28
6-17	Gate Linkage and Sensor Circuit . . . . .	6-30
6-18	Exit Gear Lever . . . . .	6-32
6-19	Exit Leading Edge Jam . . . . .	6-33
6-20	Exit Sensor . . . . .	6-34
6-21	Exit Leading Edge Jam . . . . .	6-35
6-22	Exit Motor . . . . .	6-36
7-1	Overall Troubleshooting Flow . . . . .	7-1
7-2	Background Staining . . . . .	7-4
7-3	Misregistration Grid Pattern . . . . .	7-13
7-4	Skew Measurement . . . . .	7-15
7-5	HVPSA . . . . .	7-20
7-6	Erase LEDs Diagram . . . . .	7-21
7-7	Developer Bias Connector . . . . .	7-22
8-1	Covers, Doors, and External Parts . . . . .	8-6
8-2	Parts Locator 1 . . . . .	8-8
8-3	Parts Locator 2 . . . . .	8-10
9-1	Memory SIMs . . . . .	9-31
9-2	Memory SIM location . . . . .	9-31

10-1	Cleaning the Transfer/Separation Charger . . . . .	10-8
11-1	DEClaser 3200 with LCIT . . . . .	11-1
11-2	LCIT External View . . . . .	11-2
11-3	Internal Rear Side View . . . . .	11-4
11-4	Internal Front Side View . . . . .	11-6
11-5	LCIT Elevator Motor Connectors . . . . .	11-9
A-1	Parallel Port Connector . . . . .	A-1
A-2	Connector Locations . . . . .	A-8
A-3	15 Vdc Distribution . . . . .	A-9
A-4	Overall Distribution . . . . .	A-10
A-5	5 Vdc Distribution . . . . .	A-11
A-6	24 Vdc Distribution . . . . .	A-12
C-1	Overall Troubleshooting Flow . . . . .	C-1
E-1	DEC PPL3 Submenu . . . . .	E-2
E-2	LJ2D Submenu . . . . .	E-9
E-3	PostScript Submenu . . . . .	E-15

## Tables

1-1	Printer Components: Front View . . . . .	1-3
1-2	Printer Components: Rear View . . . . .	1-5
1-3	Printer Components: Inside View . . . . .	1-7
1-4	Size-sensing Magnets and Paper Sizes . . . . .	1-13
2-1	Control Panel Keys, Indicators, and Displays . . . . .	2-2
2-2	Printer Status Messages . . . . .	2-6
2-3	Menu Mode Keys . . . . .	2-9
2-4	Protocol . . . . .	2-11
2-5	A and B Cassette Sizes . . . . .	2-12
2-6	ALARM Feature . . . . .	2-12
2-7	COMM INTERFACE Menu . . . . .	2-13
2-8	DISPLAY LANGUAGE Values . . . . .	2-14
2-9	COMM ERROR Values . . . . .	2-14
2-10	Defaults Menu . . . . .	2-15
2-11	TEST Menu . . . . .	2-16
3-1	1701 Special Function Codes . . . . .	3-3
3-2	1701 Test Codes . . . . .	3-5
4-1	Start FIP . . . . .	4-2

5-1	Error Code Master Lookup Table . . . . .	5-3
5-2	Memory SIM and Socket Allocation . . . . .	5-35
6-1	CLEAR PAPER PATH Error Code Lookup Table . . . . .	6-3
6-2	Cassette Size-sensing . . . . .	6-25
7-1	Image Defect Lookup . . . . .	7-2
8-1	DEClaser 3200 Recommended Spares List (RSL) . . . . .	8-1
8-2	LCIT Recommended Spares List (RSL) . . . . .	8-4
8-3	Covers, Doors, and External Parts . . . . .	8-7
8-4	Parts Locator 2 . . . . .	8-11
9-1	Memory SIM and Socket Allocation . . . . .	9-30
9-2	DC Control Board Harness . . . . .	9-38
11-1	LCIT External View . . . . .	11-3
11-2	Internal Rear Side View . . . . .	11-5
11-3	Internal Front Side View . . . . .	11-7
11-4	LCIT Error Code Lookup Table . . . . .	11-10
A-1	Parallel Interface Pin Assignment . . . . .	A-2
A-2	Serial Interface . . . . .	A-4
A-3	Cables and Adapters . . . . .	A-5
A-4	Accessories and Supplies . . . . .	A-6
B-1	Cassette Feed Paper Sizes . . . . .	B-2
B-2	Paper Specifications . . . . .	B-3
B-3	Transparency Sizes . . . . .	B-4
B-4	Transparency Specifications . . . . .	B-5
B-5	Self-Adhesive Label Specifications . . . . .	B-5
B-6	DEClaser 3200 Specifications . . . . .	B-6
D-1	Training . . . . .	D-1
D-2	Tools . . . . .	D-2
D-3	Documentation . . . . .	D-3

---

# Preface

This book is intended to assist the Digital Service engineer to repair and service the DEClaser 3200 printer in the field environment. Before attempting to use the book, you must attend the specific DEClaser Digital Service training course and all other prerequisite training courses. Section D.1 lists all recommended courses.

## Conventions

The following conventions are used throughout this service guide:

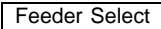
Convention	Description
<b>Note:</b>	Notes provide additional information.
<b>Caution:</b>	Cautions emphasize information for preventing damage to the equipment or software.
<b>Warning:</b>	Warnings emphasize information for preventing personal injury.
	A box is used to refer to a control panel key. Chapter 2 describes the control panel keys.
1. 2. 3.	Numbered steps indicate the recommended sequence of each step within a procedure.
• • •	Bulleted steps allow you to determine which step to do first.
a. b. c.	Alphabetized steps indicate a series of substeps under a bulleted or numeric main step.

---

# About This Service Guide

The following table describes the DEClaser 3200 Printer Service Guide:

<b>Section</b>	<b>Comments</b>
Chapter 1	Provides physical and functional descriptions of the printer and the cassettes.
Chapter 2	Describes the control panel operation and customer-accessible menus, test patterns, and printouts.
Chapter 3	Describes service-accessible menus; the test patterns and printouts; and the special functions and tests. The test codes enable you to operate any discreet components (solenoid, clutch, sensor, and so on) thus verifying the operability of each electrical circuit.
Chapter 4	Describes the overall and non-error-code troubleshooting. Section 4.1 is the overall fault isolation procedure (Start FIP). By completing the start FIP, you verify the correct operation of the printer or isolate a malfunction. The Start FIP will direct you to other specific FIPS, described in Chapters 4, 5, 6, 7, and 10.
Chapter 5	Interprets the display panel error codes and gives a FIP for all but the paper jam codes.
Chapter 6	Describes the paper jam FIPs.
Chapter 7	Describes the image defect and print quality FIPs.
Chapter 8	Contains the Recommended Parts List (RSL) and a section for finding the location of a named part.
Chapter 9	Provides instructions on how to remove and replace the major assemblies within the DEClaser 3200 printer.
Chapter 10	Defines the DEClaser 3200 adjustments and cleaning procedures.
Chapter 11	Describes the High Capacity Feeder (LCIT), which is optional equipment for the DEClaser 3200 printer. This chapter also contains the nonerror code LCIT FIPs and the LCIT removal and replacement procedures.
Appendix A	Contains technical and functional information.

---

<b>Section</b>	<b>Comments</b>
Appendix B	Gives print media and operational specifications for the printer.
Appendix C	Describes the Total Call Concept (TCC) procedure.
Appendix D	Lists training, tools, and related documentation.
Appendix E	Provides information about the features and values available on the three protocol submenus. You select these menus from the PROTOCOL feature of the Set Up menu which is described in Section 2.4. The DEC PPL3 and LJ2D protocols are resident in every printer while the PostScript protocol is resident after installation of the PostScript description language (PDL) board.
Index	The index section is at the rear of the book. Use the index to search for information.

---



---

# Physical and Functional Description

This chapter provides a physical and functional description of the DEClaser 3200 printer.

## 1.1 Safety Warnings

**Note:** *The DEClaser 3200 printer complies with all United States government safety regulations applicable to ozone gas emissions and laser beam light exposure.*

**Laser Safety To Be Done** The DEClaser 3200 printer complies with 21 CFR Chapter 1, Subchapter J, as a Class 1 laser product under the U.S. Department of Health and Human Services (DHHS) Radiation Performance Standard, according to the Radiation Control for Health and Safety Act of 1968. The DEClaser 3200 printer does not emit hazardous light since the laser beam is totally enclosed during all modes of customer operation and maintenance.

**Warning:** *Use of controls or adjustment procedures other than those specified in this guide may result in hazardous laser light exposure.*

## 1.2 External Description

### 1.2 External Description

Figure 1-1 presents a view of the front and right side of the printer. To find the names and function of the items pointed to see Table 1-1.

Figure 1-1 Printer Components: Front View

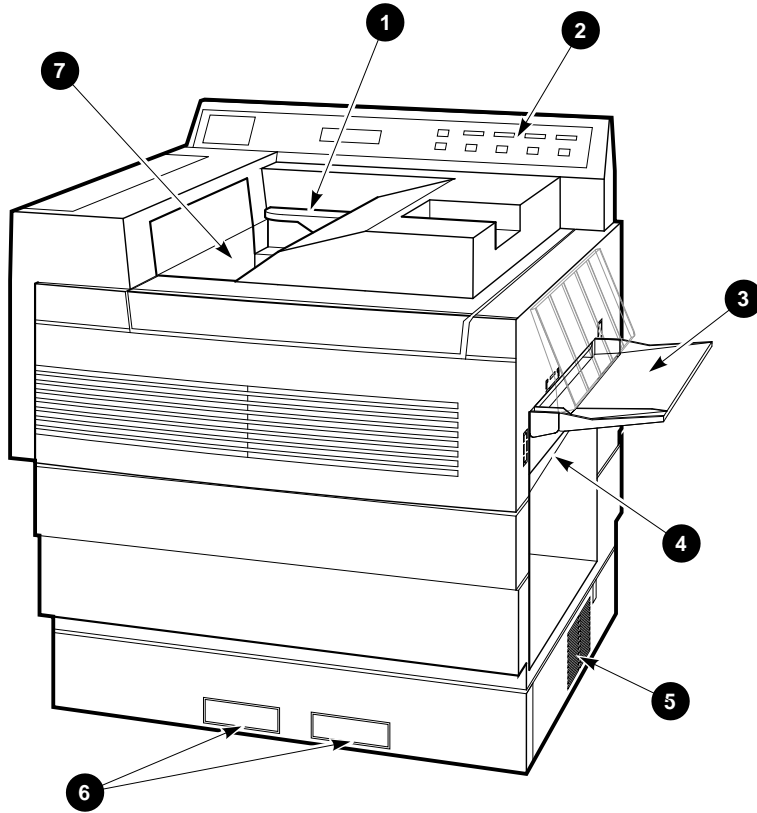

MLO-006248

## 1.2 External Description

**Table 1–1 Printer Components: Front View**

Component	Function
① Top cover release lever	Lifting this lever unlocks the top cover, also referred to as the top door, so it can be opened to clear paper jams or to perform printer maintenance.
② Control panel	The control panel consists of a graphic display, a message display, indicator lights, and push-button function keys. The displays provide information on printer status. The indicators alert the user to functional and alarm conditions. The keys control the operation of the printer. See Chapter 2 for more information.
③ Manual feed tray and bypass slot	The manual feed tray is removed when you install the optional feeder. The bypass slot is used for manual or optional equipment paper feeding, such as the LCIT. The bypass slot is not labeled but is referred by Set Up menus as 3 or 4.
④ Right cover or feed door	The right cover is a door that opens for removing stalled paper and for clearing the jam indication.
⑤ Air vent	The video cooling fan exhausts air through this vent. Be sure that it is not blocked.
⑥ Font cartridge slots	These two slots accept optional font and emulation program cartridges.
⑦ Output tray	Printed sheets are stacked in facedown orientation. The output tray overflow lever senses when the tray is full.

## 1.2 External Description

Figure 1-2 presents a view of the rear and left side of the printer. To find the names and function of the items pointed to see Table 1-2.

**Figure 1-2 Printer Components: Rear View**

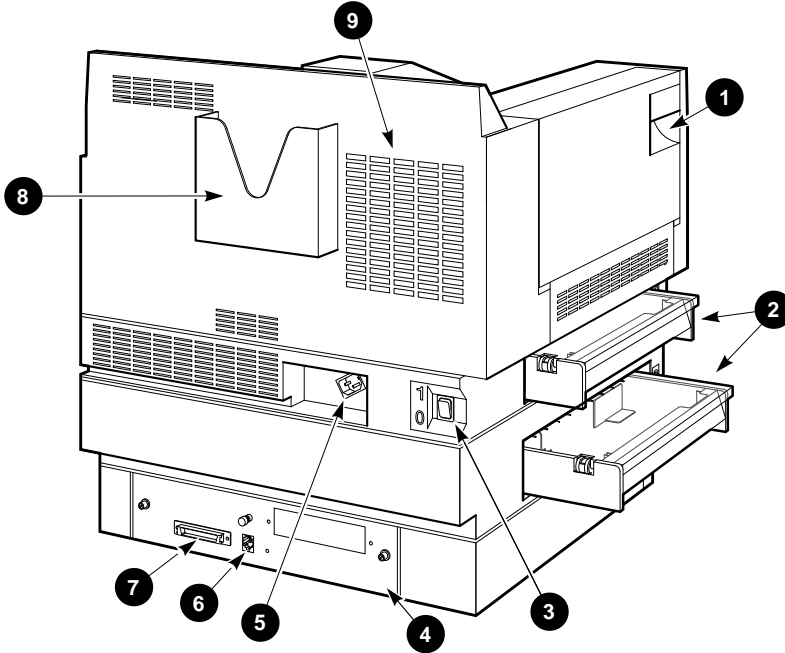

MLO-006249

## 1.2 External Description

**Table 1–2 Printer Components: Rear View**

Component	Function
① Left (exit) side door	The left side door opens to remove stalled paper, to clear the jam indications, and to access the fuser cleaning pad.
② Upper and lower paper cassettes	Each cassette holds up to 250 sheets of paper. The upper and lower cassettes are also referred to as tray 1 and tray 2.
③ Power switch	Disconnects the printer from the ac power line.
④ Future options cover	This cover can be removed to install a future connectivity option.
⑤ Power cord receptacle	This is where the power cord connects to the printer.
⑥ Serial interface connector	Accepts the standard 6-pin MMJ connector and is mechanically and electrically compatible to the EIA–423–A and CCITT V.10 interface specifications.
⑦ Parallel interface connector	Accepts a 32-pin connector and is used for parallel interfacing to a host computer system. The connector is mechanically and electrically compatible to the Centronics protocol.
⑧ Reference guide holder	This is used to store the reference guide.
⑨ Air vent	The fuser fan exhausts air through this vent.

## 1.2 External Description

Figure 1-3 shows components inside of the printer. To find the names and function of the items pointed to see Table 1-3.

**Figure 1-3 Printer Components: Inside View**

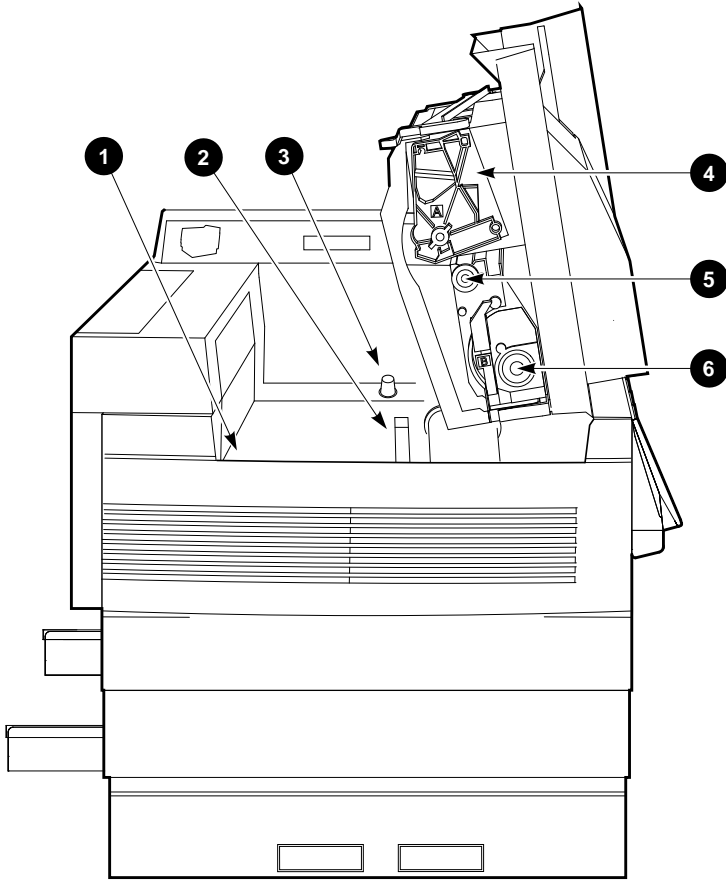

MLO-006631

**Table 1–3 Printer Components: Inside View**

Component	Function
① Fusing unit	The fusing unit cleaning pad is accessed through the left exit side door. The customer should replace the cleaning pad whenever they install a fresh developer unit. A customer services technician must replace the fusing unit after 300,000 pages.
② Transfer and separation charger	The charger snaps into place. To prevent image defects, the customer can remove and clean the charger.
③ Print density adjustment knob	Turn right to increase toner and darken the print. Turn left to decrease toner and lighten the print.
④ Photoreceptor drum	A latent image is produced by the laser beam on the light-sensitive surface of the drum. Because the drum is light-sensitive, it should not be exposed to ambient light for more than 10 minutes. The electronic device encased in the print drum contains ID and status information. See Table 3–1 for more information.
⑤ Developer cartridge or unit	This user-replaceable component contains the developer roller and the toner cartridge. The electronic device encased in the developer cartridge contains ID and status information. See Table 3–1 for more information.
⑥ Toner cartridge	The mechanical agitator in each toner cartridge evenly distributes the toner and feeds toner into the developer roller. The electronic device encased in the toner cartridge contains ID and status information. See Table 3–1 for more information.

### 1.3 Cassette Feeders

The upper and lower cassette slots, shown in Figure 1–2, can accept fixed-size or adjustable cassettes.

Each paper cassette holds up to 250 sheets of 80 g/m<sup>2</sup> (20 lb.) paper. Appendix B lists the paper specifications that ensure good print quality and minimal paper jams.

## 1.3 Cassette Feeders

### 1.3.1 Loading Cassettes

Figure 1–4 shows a loaded cassette and Figure 1–5 shows the important parts of the cassette.

Remember the following before you remove or load a paper cassette:

- When a cassette is empty, the Error indicator lights. Press  to display the message ADD PAPER TO TRAY 1 (or 2).
- Do not remove the upper cassette when duplex printing, a paper jam will occur. Feeding may occur from either cassette, but the top of the upper cassette is part of the duplex refeed paper path.
- Push down and lock the paper elevator or tray (shown in ❶, Figure 1–5) before loading paper. The elevator lock releases as the cassette is installed in a slot.
- Make sure the cassette top is clean and free of stickers or labels that can catch and jam refeed sheets.
- From the following submenus, you select the cassette and the failover characteristics. To display a submenu, first press , then select the PROTOCOL feature. See Section 2.4 and Section 2.4.1 for more information. Failover allows the printer to switch cassettes without stopping when the selected cassette is empty.

Selected Protocol	Submenu Names	Submenu Documentation Location
DEC PPL3	TRAY SELECTION	Section E.1.1
LJ2D	TRAY SELECTION	Section E.2.2
PostScript	TRAY SWITCH SEQ TRAY SWITCHING	Section E.3.5 Section E.3.4

- Fan and jog the paper before loading.
- Overloading will cause paper jams and skewing so keep the paper stack height below MAX limit line.
- Make sure the corners are under the metal snubbers (shown in Figure 1–4) to prevent shingle jams and multiple sheet feeds.
- Prepunched paper holes face the front of the printer.
- When printing simplex forms and letterheads, load facedown, top edge inserted first.

## 1.3 Cassette Feeders

- When printing duplex, load forms and letterheads faceup, bottom edge inserted first.

**Figure 1-4 MAX Limit and Snubbers**

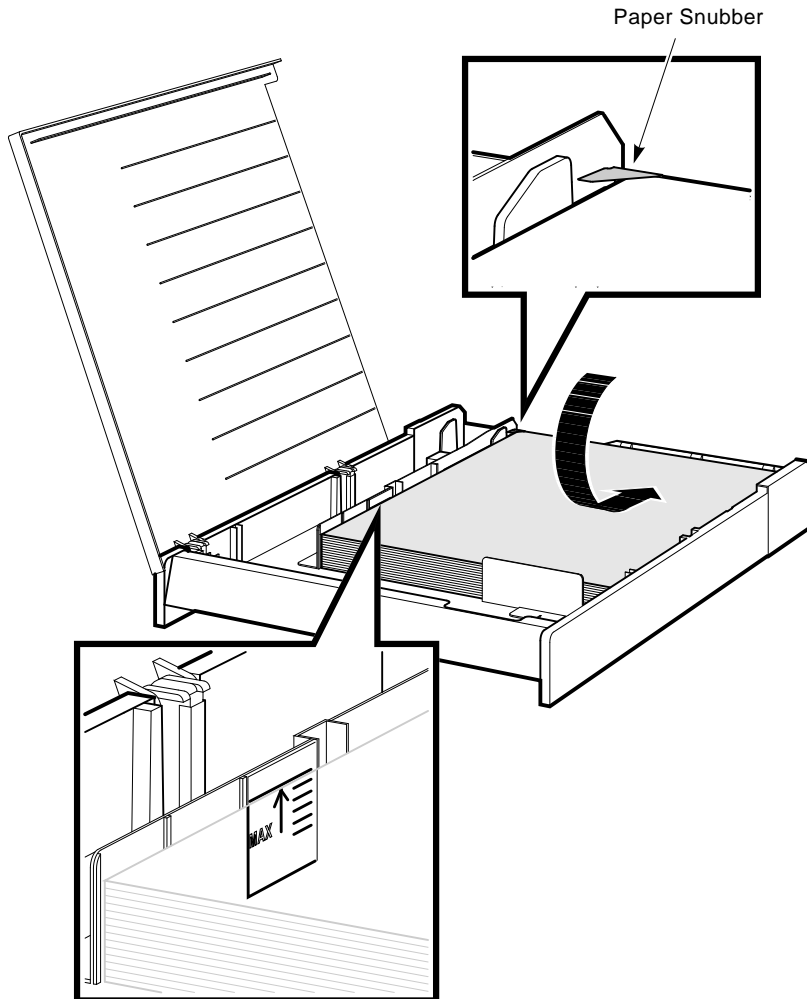

MLO-006271

## 1.3 Cassette Feeders

### 1.3.2 Adjustable Cassette

The adjustable paper cassette accepts sheet widths from 182 mm to 216 mm (7.17 in. to 8.5 in.) and lengths from 254 mm to 356 mm (10 in. to 14 in.).

When the adjustable cassette is installed, size of the paper and image must be set by you or the host computer. Through the control panel ADJ CASSETTE menu, you can select from many standard sizes, or enable the host system. Refer to Section 2.4 for cassette adjust menu information. Furthermore, the customer can identify each adjustable cassette as an A or B cassette, and thus load two different sizes of paper.

Figure 1–5 shows the adjustable cassette and numbers the significant components.

- ① Paper elevator or tray
- ② MAX limit line
- ③ Paper length slide
- ④ Cassette top cover
- ⑤ Paper width slider
- ⑥ Location of the size-sensing magnets. See Figure 1–6 for a close-up of adjustable magnets.

**Figure 1–5 Adjustable Cassette**

Space = 19, mlo-006973

## 1.3 Cassette Feeders

### 1.3.2.1 A and B Cassettes

Figure 1–6 shows the size-sensing magnets on the adjustable cassette. The top size-sensing magnet can be set so the printer will identify the cassette as an A or B cassette. Section 2.4.2 tells you how to set the paper size of the A or B adjustable cassette into the memory of the printer.

#### Figure 1–6 Adjustable Size-sensing

Space = 20, mlo-006972

### 1.3.3 Cassette Size-sensing

Figure 1–7 shows the location of the three magnets that mount on the cassette and actuate the size-sensing switches. Table 6–2 relates the tray size to magnet configuration.

When a cassette is installed, a combination of switches and resistors are connected into the circuit. The DC control board measures the resistance to determine the size of the installed cassette.

## 1.3 Cassette Feeders

Figure 1–7 Tray 1 Size-sensing Magnets

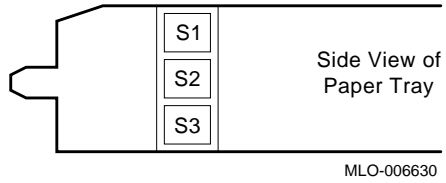

Table 1–4 Size-sensing Magnets and Paper Sizes

Cassette Paper Size	Size-sensing Magnets		
	S1	S2	S3
Cassette not installed	OFF	OFF	OFF
Adjustable A	ON	OFF	OFF
A4 210 x 297 mm	OFF	ON	OFF
Legal 8.5 x 14	OFF	ON	ON
Adjustable B	ON	OFF	ON
A5 <sup>1</sup>	ON	ON	OFF
Letter 8.5 x 11 in	ON	ON	ON

<sup>1</sup>Cassette size not available from Digital.

OFF = No magnet in position.  
ON = Magnet in position

## 1.4 Optional Equipment

### 1.4 Optional Equipment

The following DEClaser 3200 equipment is optional and can be installed by the customer:

- When the PostScript option is installed, the printer becomes a DEClaser 3250. The PostScript option consists of the PDL board, a coprocessor single in-line module (SIM), and three 2-Mb SIMs.

The PostScript description language (PDL) code resides on the PDL board which plugs into a socket on the video control board. Once installed, you can select it from the PROTOCOL feature of the Set Up menu as described in Section 2.4. Section E.3 describes the features, values, and submenus that appear when you select the postscript protocol.

- The coprocessor board mounts in a SIM socket J10 on the video control board. It provides processing power for the PostScript interpreter. Without a functional coprocessor, the printer will fail to operate in PostScript mode.
- The 2-Mb and ½-Mb expansion memory SIMs mount in sockets on the video control board. Each video control board comes with a ½-Mb SIM installed in socket J15. See Table 5–2 for socket allocation information.
- The LCIT holds up to 1500 sheets of paper. It feeds the sheets into the bypass slot and receives power and command signals from the DC control board through an 8-pin modular type connector. See Chapter 11 for a full description.
- A number of cartridges are available that plug into the font cartridge slots on the front panel. The read-only memory (ROM) in these cartridges are tested by power-up diagnostics on the video control board.

---

## Control Panel Operations and Menus

This chapter is about the following control panel operation and functions:

- Section 2.1 identifies and describes the control panel keys, indicators, and display. The format of the display messages is also shown.
- Section 2.2.1 describes the DEC PPL3 and PostScript operational status messages.
- Section 2.3 describes the structure of the six main customer and service menus, and the keys you use to move, select, and save the features and values. See Appendix E for more Set Up menu information.
- Section 2.4 describes the Set Up menu features such as the protocol and communications parameters.
- Section 2.5 describes the Defaults menu which you use to recall and save factory and user defaults. Defaults are stored values for all the features of the Set Up menu.
- Section 2.6 describes the Test menu which you use to print the configuration and font status sheets and to turn on and off the Control Representation mode.

### 2.1 Control Panel Keys and Indicators

Figure 2–1 shows the location of the DEClaser 3200 control panel indicators and keys and Table 2–1 describes their function and operation.

## 2.1 Control Panel Keys and Indicators

Figure 2-1 Control Panel

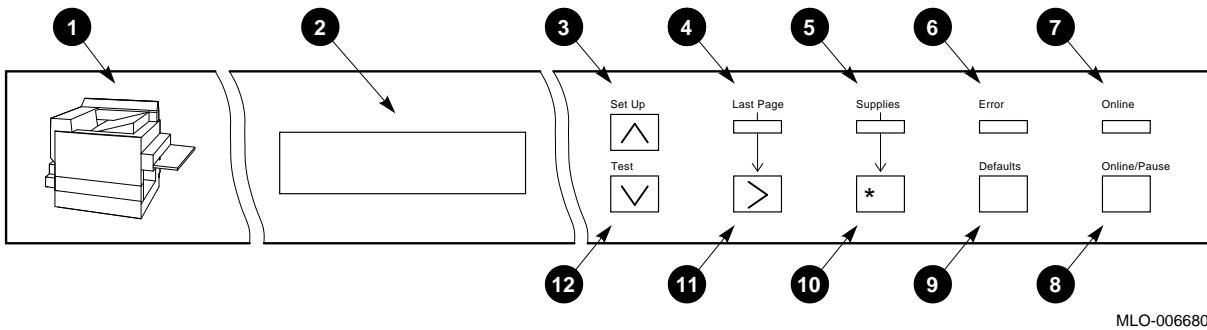

MLO-006680

Table 2-1 Control Panel Keys, Indicators, and Displays

Key Indicator	Function
① Graphic Display	The graphic display indicates cassette selections and the locations of jams and expired consumables. The paper tray indicators light green; all other indicators light red.
② Message Display	The message display is a 2-line, 16-character liquid crystal display that shows status messages in conjunction with the other indicators. Section 2.2 explains the display format. See Table 5-1 for a brief interpretation of the error code and for a pointer to the in-depth troubleshooting procedure.
③ <input type="button" value="Set Up"/> / <input type="button" value="^"/>	<p>If the printer is off line or PAUSED, pressing this key invokes the following:</p> <ul style="list-style-type: none"> <li><input type="button" value="Set Up"/> invokes the Set Up menu, as shown in Section 2.4.</li> <li><input type="button" value="Set Up"/> with <input type="button" value="Test"/> invokes the 1948 Service Menu, as shown in Section 3.2.</li> <li>When in a Set Up or service menu, pressing <input type="button" value="^"/> causes the display to scroll through selections or numeric values.</li> <li>The key is uniquely defined in several of the service menus.</li> </ul>

(continued on next page)

## 2-2 Control Panel Operations and Menus

## 2.1 Control Panel Keys and Indicators

Table 2–1 (Cont.) Control Panel Keys, Indicators, and Displays

Key Indicator	Function
④ Last Page (yellow)	<p>The Last Page indicator works in conjunction with <input type="button" value="&gt;"/> to print data remaining in the print buffer.</p> <p>If on, there is data in the buffer. Press <input type="button" value="Online/Pause"/> then <input type="button" value="&gt;"/> to print and empty. Some control panel operations are inhibited until the buffer is emptied. If flashing, the buffer is receiving data. If off, the buffer is empty.</p>
⑤ Supplies (yellow)	<p>The Supplies indicator lights to inform the operation that a consumable is running low or has completely run out. When the indicator lights, press <input type="button" value="*"/> to display the message.</p>
⑥ Error (amber)	<p>The Error indicator lights when an error condition exists that stops the printer. If enabled, the beeper will sound. If an error message and code fails to appear on the display, press <input type="button" value="*"/> to display one. See Table 5–1 for a brief interpretation of the error code and for a pointer to the in-depth troubleshooting procedure.</p> <p>The indicator goes off when the error condition is cleared. Opening and closing the top, left, or right doors will clear all but a call service error.</p>
⑦ Online (green)	<p>If on, the printer is online and controlled by the host computer. The host computer can send print data and printer control commands. If off, the printer is paused and under control of the control panel keys. If flashing, the printer is warming up or printing the current job before pausing.</p>
⑧ <input type="button" value="Online/Pause"/>	<p>This key toggles the printer between the online and paused (offline) modes. If pressed while printing, the Online indicator flashes until the current job finishes printing.</p>

(continued on next page)

## 2.1 Control Panel Keys and Indicators

Table 2–1 (Cont.) Control Panel Keys, Indicators, and Displays

Key Indicator	Function
⑨ <input type="button" value="Defaults"/>	<p>This key performs the following functions:</p> <ul style="list-style-type: none"><li>• When DEC PPL3 or PostScript protocol is invoked, this key invokes the DEFAULTS menu. See Section 2.5 or Section E.1, DEC PPL3 Submenu, for more information.</li><li>• When LJ2D protocol is invoked, this key bypasses paper tray display messages. See Section E.2, LJ2D Submenu, for additional information about paper tray errors under the LJ2D protocol.</li><li>• Simultaneously holding down <input type="button" value="&gt;"/> and <input type="button" value="Defaults"/> while powering on causes the printer to enter the test print or 1701 test diagnostics. See Chapter 3 for additional information.</li></ul>
⑩ <input type="button" value="*"/>	<p>The following functions are performed by this key:</p> <ul style="list-style-type: none"><li>• In any menu, this key enters or invokes settings, test codes, and commands.</li><li>• When the Supply indicator is on, this key displays the supplies message.</li><li>• Press the key to clear a soft error condition and continue printing.</li></ul>
⑪ <input type="button" value="&gt;"/>	<p>The following functions are performed by this key:</p> <ul style="list-style-type: none"><li>• When in a Set Up or SERVICE menu, pressing <input type="button" value="^"/> causes the display to scroll through selections or numeric values.</li><li>• When the Last Page indicator is on, press <input type="button" value="Online/Pause"/> to set the printer to the paused mode, then press <input type="button" value="&gt;"/> to print the remaining data in the buffer.</li><li>• Simultaneously holding down <input type="button" value="&gt;"/> and <input type="button" value="Defaults"/> while powering on causes the printer to enter the test print or 1701 test diagnostics. See Chapter 3 for additional information.</li></ul>

(continued on next page)

## 2.1 Control Panel Keys and Indicators

**Table 2–1 (Cont.) Control Panel Keys, Indicators, and Displays**

Key Indicator	Function
<p>⑫ <input type="button" value="Test"/> / <input type="button" value="V"/></p>	<p>This key performs the following functions:</p> <ul style="list-style-type: none"> <li>• <input type="button" value="Set Up"/> with <input type="button" value="Test"/> invokes the 1948 Service Menu, as shown in Section 3.2.</li> <li>• When in a Set Up or SERVICE menu, press <input type="button" value="V"/> to scroll through selections or numeric values.</li> <li>• This key is uniquely defined in several of the service menus.</li> </ul>

## 2.2 Operational Display Format

Figure 2–2 shows the display that appears during normal operation of the DEClaser 3200 printer. The display is divided into four sections for all modes of operation.

**Figure 2–2 Printer Status Display**

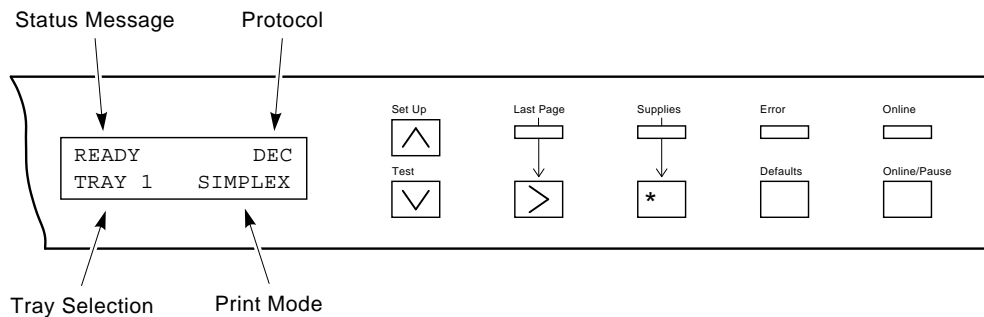

MLO-006480

- Printer status messages are listed in Table 2–2.
- The protocol section identifies the current operating protocol. DEC PPL3 and LJ2D are the standard resident protocols. The optional PostScript protocol when installed is also resident. Appendix E lists the menus and messages for each protocol.
- Tray selections identify the current input device.

## 2.2 Operational Display Format

- The print mode shown is one of several DEC PPL3 print modes available under the DUPLEX submenu, as shown in Section E.1.2.

### 2.2.1 Operational Status Messages

The DEC PPL3, LJ2D, and PostScript operational status messages are shown and described in Table 2–2. See Table 5–1 for error code information and fault isolation procedures (FIPS). See Section 2.4 and Appendix E for Setup Menu information.

**Table 2–2 Printer Status Messages**

Status Message	Meaning
READY	This message is accompanied by the Ready indicator and means the printer is on line, ready to receive and print data.
PAUSED	The printer is paused or off line and cannot print but will receive data until the buffer fills. Press <input type="button" value="Online/Pause"/> to continue.
BUSY	The printer is receiving, processing, or printing data. Pressing <input type="button" value="Online/Pause"/> while the BUSY message is displayed, causes the Online indicator to flash. The flashing stops when the printing finishes.
LAST PAGE <sup>1</sup>	This message is accompanied by the Last Page indicator and means that the data buffer is full. Press <input type="button" value="&gt;"/> to empty and print the data buffer.
PLEASE WAIT	This message is displayed during either of the following conditions: <ul style="list-style-type: none"><li>• The printer is warming up.</li><li>• After clearing a printer error condition (for example, replacing the toner cartridge), this message is displayed briefly while the printer is reinitializing to its state before the error occurred.</li></ul>

<sup>1</sup>This message is displayed only when DEC PPL3 or LJ2D protocol is selected.

(continued on next page)

## 2.2 Operational Display Format

Table 2–2 (Cont.) Printer Status Messages

Status Message	Meaning
POWER SAVER ON	This message is displayed after the printer has been idle for a period of time. The factory default is 2 hours but the interval can be set to 0–2.7 hours, in 15 minute increments, through the 1701 special functions code 0282.90. See Table 3–1. When the message is displayed, the fusing unit heater is turned off, thus saving power. The printer exits the Power Saver Mode when printer receives a print job from the host or from the control panel, or if any printer cover is opened and then closed.
WAITING <sup>2</sup>	The print job context is active, but there is no data to process.
WAIT FOR PAUSED <sup>2</sup>	Informs the operator that the control panel function requested cannot be performed because a PostScript job is currently being processed (PostScript operator “allowjobreset” is true).
PRESS * TO ABORT <sup>2</sup>	Instructs the operator to press <input type="checkbox"/> * to abort the current print job (PostScript operator “allowjobreset” is false).
INITIALIZING PS <sup>2</sup>	Displayed when the PostScript protocol is selected but the printer is not ready to accept data from the host.
TEST PRINT PS <sup>2</sup>	This message is displayed for about 45 seconds while the PostScript startup page is building.

<sup>2</sup>This message is displayed only when the PostScript protocol is selected.

## 2.3 About the Customer and Service Menus

The following customer and service menus are available within the DEClaser 3200 printer. Customer menus are accessible through a single stroke of a control panel key. To access a service menu, a special code or procedure is required which is not published in the *DEClaser 3200 Printer Operator's Guide*.

Customer Menus	Service Menus
Section 2.4, Set Up Menu	Section 3.3, Test Print Menu
Section 2.5, Defaults Menu	Section 3.2, 1948 Service Menu
Section 2.6, Test Menu	Section 3.1, 1701 Special Function and Test Codes

## 2.3 About the Customer and Service Menus

### 2.3.1 Customer Menus

Customer menus are available when the printer is paused. Some menu features are accessed by the control panel and by commands from the host. For information about selecting features using commands from the host computer, see the *Digital ANSI-Compliant Printing Protocol Level 3 Programming Reference Manual* and the *Digital ANSI-Compliant Printing Protocol Level 3 Programming Supplement*.

### 2.3.2 Set Up Memory Organization

Figure 2-3 shows the organization and flow characteristics of Set Up memory within the DEClaser 3200 control panel.

Figure 2-3 Set Up Memory Organization

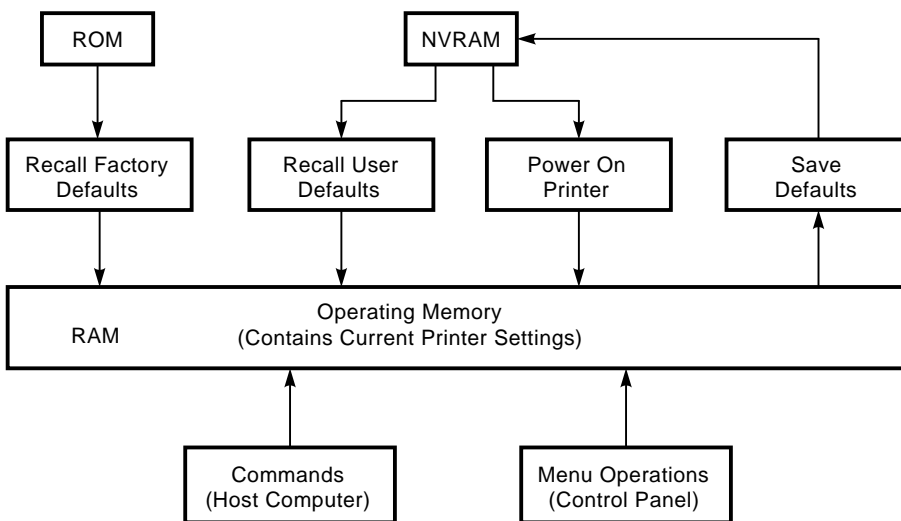

RAM      Cleared at Power-Off (Can Be Changed)  
ROM      Not Cleared at Power-Off (Cannot Be Changed)  
NVRAM    Not Cleared at Power-Off (Can Be Changed)

MLO-006465

## 2.3 About the Customer and Service Menus

### 2.3.3 Changing and Selecting Values or Defaults

Table 2–3 shows how certain keys function when in a menu. The selected protocol changes the function of some keys. See Section 2.5 for information on saving the values or defaults into NVM.

**Table 2–3 Menu Mode Keys**

Key	Function
<input type="checkbox"/> ^	<ul style="list-style-type: none"><li>o Returns to the previous level of operation in the menu.</li><li>o Increases numeric values in LJ2D protocol.</li></ul>
<input type="checkbox"/> >	<ul style="list-style-type: none"><li>o Scrolls the menus and features to the right.</li><li>o Selects the next digit for numeric values in LJ2D protocol.</li></ul>
<input type="checkbox"/> v	<ul style="list-style-type: none"><li>o Advances to the next level of operation in the menu.</li><li>o Decreases numeric values in LJ2D protocol.</li></ul>
<input type="checkbox"/> *	<ul style="list-style-type: none"><li>o Selects the current feature or value shown on the display.</li></ul>

## 2.4 Set Up Menus

The Set Up menus and submenus are used to select and enter operating features and values. Many Set Up features and values have submenus or subvalues. For example, the Set Up feature protocol has DEC PPL3 and LJ2D protocols under it. See Appendix E for information about the DEC PPL3, LJ2D, and PostScript menus.

Figure 2–4 shows the configuration and flow of the Set Up menu. To enter the Set Up menu, first press  Online/Pause to display the PAUSE message, then press  Set Up. To exit from the Set Up menu, press  Online/Pause or  ^.

Figure 2-4 Set Up Menu Diagram

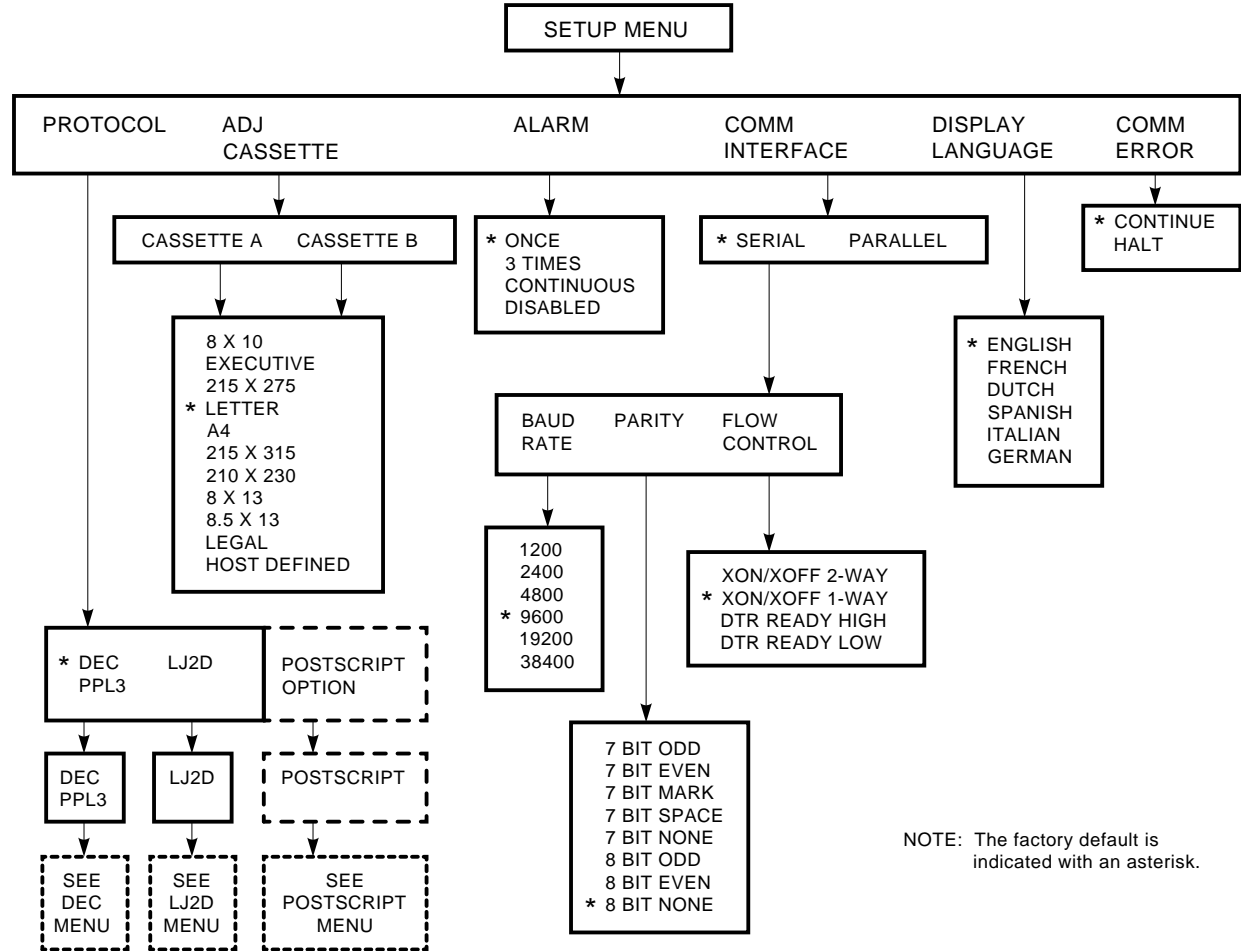

NOTE: The factory default is indicated with an asterisk.

MLO-006484

### 2.4.1 PROTOCOL

Table 2–4 shows the three protocols that you can select from this feature. Each protocol has its own submenu which is further explained in Appendix E. See Figure 2–4 to find the position of this feature in the Set Up menu.

**Table 2–4 Protocol**

Feature	Menu	Description
PROTOCOL	DEC PPL3 <sup>1</sup>	This is the resident Digital ANSI-Compliant Printing Protocol level 3 menu. Select this menu when running ANSI applications. See Section E.1 for further information.
	LJ2D	This is the resident Hewlett Packard's PCL operating protocol. See Section E.2 for further information.
	POST <sup>2</sup>	Is the optional PostScript operating protocol. See Section E.3 for further information

<sup>1</sup>Factory default setting.

<sup>2</sup>Available only when the PostScript option is installed.

### 2.4.2 ADJ CASSETTE

Table 2–5 shows the features and values that are available from the adjustable cassette menu. The values set the size of the printed image when an A or B adjustable cassette is used. See Figure 2–4 to find the position of this feature in the Set Up menu.

## 2.4 Set Up Menus

**Table 2–5 A and B Cassette Sizes**

Feature	Values	Description
CASSETTE A	LETTER <sup>1</sup>	Selects 8.5 in. x 11 in. paper size.
	A4	Selects 210 mm x 297 mm paper size.
CASSETTE B	215 X 315	Selects 215 mm x 315 mm paper size.
	210 X 330	Selects 210 mm x 330 mm paper size.
	8 X 13	Selects 8 in. x 13 in. paper size.
	8.5 X 13	Selects 8.5 in. x 13 in. paper size.
	LEGAL	Selects 8.5 in. x 14 in. paper size.
	8 X 10	Selects 8 in. x 10 in. paper size.
	EXECUTIVE	Selects 7~7.5 in. x 10~10.5 in. paper size.
215 X 275	Selects 215 mm x 275 mm paper size.	

<sup>1</sup>Factory default setting.

### 2.4.3 ALARM

Table 2–6 shows the values that are available from the ALARM feature. See Figure 2–4 to find the position of this feature in the Set Up menu.

**Table 2–6 ALARM Feature**

Feature	Values	Description
ALARM	ONCE <sup>1</sup>	Sounds a beep one time when the printer encounters an error condition.
	3 TIMES	Sounds a beep three times when the printer encounters an error condition.
	CONTINUOUS	Sounds a beep continuously until the error condition is cleared.
	DISABLED	No alarm sounds when the printer encounters an error condition.

<sup>1</sup>Factory default setting.

### 2.4.4 COMM INTERFACE

Table 2–7 shows the communication interface values that are available from the COMM INTERFACE menu. The DEClaser 3200 supports both parallel and serial interface connections. The host computer cannot set the printer's communication interface values. See Figure 2–4 to find the position of this feature in the Set Up menu.

**Table 2–7 COMM INTERFACE Menu**

Feature	Values	Subvalues	Comment
PARALLEL	–	–	Selects the (Centronics) parallel interface to communicate with the host computer.
SERIAL <sup>1</sup>	BAUD RATE <sup>2</sup>	300 600 1200 2400 4800 9600 <sup>1</sup> 19200	The speed of the printer and host must match, or communication errors will occur.
	PARITY <sup>2</sup>	8 BIT NONE <sup>1</sup> 7 BIT ODD 7 BIT EVEN 7 BIT MARK 7 BIT SPACE 8 BIT ODD 8 EVEN	Parity checking detects communication errors that occur between the printer and host computer.
	FLOW CONTROL <sup>2</sup>	XON/XOFF 2-WAY <sup>1</sup> XON/XOFF 1-WAY DTR READY HIGH DTR READY LOW	Flow control prevents the overflow of data buffers in the printer, host, and prevents data overruns or data late type errors.  When XON/XOFF is enabled, the host, printer, and DCE transmit and receive special characters that regulate the flow of serial data.  The printer asserts or negates DTR to signal the host to transmit or hold data.

<sup>1</sup>Factory default setting.

<sup>2</sup>This subvalue only appears when serial is selected.

## 2.4 Set Up Menus

### 2.4.5 DISPLAY LANGUAGE

Table 2–8 shows the values that are available from the DISPLAY LANGUAGE feature of the Set Up menu. See Figure 2–4 to find the position of this feature in the Set Up menu.

**Table 2–8 DISPLAY LANGUAGE Values**

Feature	Values	Description
DISPLAY LANGUAGE	ENGLISH <sup>1</sup>	Status and error messages, printer menus, and the configuration sheet are displayed in the selected language.
	FRENCH	
	DUTCH	
	SPANISH	Service call messages are only displayed in English.
	ITALIAN	
	GERMAN	

<sup>1</sup>Factory default setting.

### 2.4.6 COMM ERROR

Table 2–9 shows the values that are available from the COMM ERROR feature of the Set Up menu. See Figure 2–4 to find the position of this feature in the Set Up menu.

**Table 2–9 COMM ERROR Values**

Feature	Values	Description
COMM ERROR	CONTINUE <sup>1</sup>	Overrides any communication errors and continues printing.
	HALT	Displays an error message when a communications error is encountered and stops printing until the error is cleared.

<sup>1</sup>Factory default setting.

## 2.5 Defaults Menu

The Defaults menu is used to recall factory and user default selections, to save newly selected features and values, or to reset the printer.

To invoke the Defaults menu, first press **Online/Pause** to display PAUSE, then press **Defaults** to invoke the menu. Table 2–10 describes and shows the features on the Defaults menu. Use **>**, **^**, **v**, and **\*** to scroll and select Default menu features.

**Table 2–10 Defaults Menu**

Feature	Description
RECALL FACT DFT	Loads the factory default settings from ROM into the operating memory for current use.
RECALL USER DFT <sup>1</sup>	Loads the settings saved by the user from NVRAM into the operating memory for current use.
SAVE DEFAULTS <sup>1</sup>	Saves the currently selected features and values into NVRAM. Settings stored in NVRAM are called “user default” settings, and are loaded into the operating memory each time the printer is powered on. When the PostScript protocol is selected, the selected features and values are automatically saved in NVRAM.
PRINTER RESET <sup>1</sup>	Resets the printer to the power-up state. Loads the user default settings into operating memory.

<sup>1</sup>DEC PPL3 and LJ2D protocols only.

## 2.6 Test Menu

### 2.6 Test Menu

The Test menu is used to print out the configuration and font status sheets or to enter and exit Control Representation mode.

To invoke the Test menu, first press **Online/Pause** to display PAUSE, then press **Test**. The Test Menu is only functional when DEC PPL3 protocol is invoked. Use **>**, **^**, **v**, and **\*** to scroll and select Test menu features. The following four selections are available from the Test menu:

**Table 2–11 TEST Menu**

Feature	Description
CONFIG SHEET	See Section 2.6.1, Configuration Sheet
Font status list	See Section 2.6.2, Font Status Sheet
Start CR mode	See Section 2.6.3, Control Representation (CR) Mode
Stop CR mode	

#### 2.6.1 Configuration Sheet

Figure 2–5 is an example of a DEClaser 3200 Configuration sheet. Section 2.6 describes the Test menu. The Configuration sheet lists the following information:

- The value of each Setup feature, discussed in Section 2.4.
- The firmware versions numbers.
- A list of installed or not-installed options:
  - Page Description Language (PDL) board
  - Coprocessor board
- The amount, in bytes, of total system and available memory. Total System Memory is used to store downline loaded fonts and the data you are printing.
- The page count number increments by one (1) for each printer sheet. Write this number in the printer maintenance log.

Figure 2-5 Configuration Sheet

DECLASER 3200 Printer		Page Count 1268
Protocol Firmware V5.1-05	Page Description Language:	
Engine Firmware V2.93	Co-processor: Not Installed	
Total System Memory: 295892	Available Memory: 295892 bytes	
-----		
Set-Up Menu Settings		
Field Name	Saved Settings	Current Setting
<b>Main Menu</b>		
PROTOCOL	LJ2D	DEC PPL3
ADJ CASSETTE		
CASSETTE A	LETTER	LETTER
CASSETTE B	LETTER	LETTER
ALARM	ONCE	ONCE
COMM INTERFACE	SERIAL	PARALLEL
BAUD RATE	NA	19200
PARITY	NA	8 BIT NONE
FLOW CONTROL	NA	XON/XOFF 1-WAY
BUSY POLARITY	BUSY HIGH	NA
DISPLAY LANGUAGE	ENGLISH	ENGLISH
COMM ERROR	CONTINUE	CONTINUE
-----		
<b>DEC PPL3</b>		
TRAY SELECTION	TRAY 1	TRAY 1
DUPLEX	SIMPLEX NORMAL	DUPLEX NORMAL
MEMORY MGMT	PARTIAL	PARTIAL
AUTO WRAP	ON	ON
NEW LINE	OFF	
USER PREF SET	DEC SUPPLMT SET	DEC SUPPLMT SET
DEVICE ID	DEC PPL3	DEC PPL3
POWER-UP MESSAGE	OFF	OFF
-----		
<b>LJ2D</b>		
COPIES	1	1
TRAY SELECTION	TRAY 1	TRAY 1
DUPLEX	DISABLED	DISABLED
FONT NUMBER	1	1
PAPER SIZE	LETTER	LETTER
ORIENTATION	PORTRAIT	PORTRAIT
FORM LENGTH	60	60
PAGE BUFFERS	PARTIAL	PARTIAL
SYMBOL SET	ROMAN-6	ROMAN-8
-----		
<p>To order your DECLASER 3200 family supplies options, contact your local Digital Sales office or local Authorized Digital Distributor.</p>		

MLO-006632

## 2.6 Test Menu

### 2.6.2 Font Status Sheet

Figure 2–6 shows a portion of the font status list. The list of resident fonts can be several pages long. Fonts are selected by escape sequences sent from the host computer. You cannot select a font from the control panel. For additional information about selecting fonts, consult the *Digital ANSI-Compliant Printing Protocol Level 3 Programming Reference Manual*.

### 2.6.3 Control Representation (CR) Mode

The Control Representation or Character Dump mode is used to print out raw (unprocessed) data or commands sent from the host computer. When the mode is activated and the printer is on line, the printer prints all the normally invisible control characters, such as carriage returns and line feeds.

For additional information about the Control Representation mode, consult the *Digital ANSI-Compliant Printing Protocol Level 3 Programming Reference Manual*.





---

## Service Menus and Tests

This chapter is about the following service menus, diagnostic tests, and test patterns:

- Section 3.1.2, 1701 Special Function Codes
- Section 3.1.3, 1701 Diagnostic Tests
- Section 3.2, 1948 Service Menu
- Section 3.3, Test Print Menu
- Section 3.4, Service Shutdown and Power-Up Procedure

**Note:** *Special codes and power up procedures are required to invoke and access the service menus that are discussed in this chapter. These codes are only published in this service guide.*

### 3.1 1701 Special Function and Test Codes

Table 3–1 and Table 3–2 list all of the codes that you can use to obtain status information, test, and adjust the DEClaser 3200 printer.

The 1701 special functions and tests are protocol independent and will operate if the video control board is disconnected or connected.

Some of the function codes can be entered directly without punching in the 1701 codes. Those codes are designated direct codes. See Table 3–1 for a list of function codes.

Chapter 10 describes all adjustment procedures.

## 3.1 1701 Special Function and Test Codes

### 3.1.1 Starting, Stopping, and Running 1701 Menu and Codes

Use the following procedures to start and stop the 1701 menu:

#### Starting the 1701 Menu

1. Simultaneously press and hold **>** and **Defaults** while turning on the printer power. Release the keys when you see four zeros **0000** displayed.
2. Use **^**, **v**, and **>** to set the display to 1701.
3. Press and release **\*** once to enter the 1701 code. Now enter and run any of the special functions or test codes listed in Table 3-1 and Table 3-2.

**Note:** *Because no user-friendly prompt or any other indication of success is displayed, some people press **\*** a second time. The response to the second press is the **Invalid** error message. This error appears because 1701 is not a valid test code.*

#### Stopping the 1701 Menu

To stop the 1701 menu and return to normal operation, power the printer down and then up.

#### Running and Selecting a Function or Test Code

Use the following procedure to enter and run a 1701 function or test code:

1. To start the 1701 menu, see the above procedure.
2. Look up the desired 1701 code in Table 3-1 or Table 3-2.
3. Use **^**, **v**, and **>** to set the code into the display.
4. Press **\*** to enter the code and start the test. If the INVALID message appears, you have entered an incorrect code. If the menu seems hung up, power down the printer and start again.
5. The test is running when the prompt appears. The prompts are listed next to the 1701 codes.

#### Stopping a Running Test

Use one of the following procedures to stop a running test:

1. Press **\*** to terminate most running 1701 codes. If it fails to stop, simultaneously press **>** and **Defaults**.
2. Power down the printer if it is hung and unresponsive to control panel keys.
3. The output tests (motor, solenoid, and so on) stop automatically after a 10 minute run.

## 3.1 1701 Special Function and Test Codes

### 3.1.2 1701 Special Function Codes

Table 3–1 lists all codes and the information they provide. To read or alter the values, you must enter the 1701 menu, as shown in Section 3.1. Use , , and  to enter the code and alter the value. Press  to select the value and automatically save it in NVRAM.

**Note:** For this function to work, you must select DEC PPL3 protocol, as shown in Section 2.4.

**Table 3–1 1701 Special Function Codes**

Code	Definition of Function	Display Panel/Comment
0281.00 <sup>1</sup>	The total number of prints	0000475
0281.10 <sup>1</sup>	Set/read bypass or manual slot 3	8X10            215X315
0281.11 <sup>1</sup>	Set/read upper cassette slot 1.	B4                A4
0281.12 <sup>1</sup>	Set/read lower cassette slot 2.	LEGAL           LETTER 8.5X13            251X275 210X330           MONARCH
0281.20 <sup>1</sup>	(Function does not work)	English or 2 <sup>nd</sup> language.
0281.30 <sup>1</sup>	Set/read contrast or the LCD display.	\$00–0F
0281.40 <sup>1</sup>	Beeper control	ON–OFF
0282.01	Horizontal Registration set menu.	See Section 10.3 for the adjustment procedure
0282.01		
0282.02	Vertical Registration set menu.	See Section 10.4 for the adjustment procedure.
0282.02		
0282.03	Read print cartridge identification (ID)	MCU:\$10 CRU:\$10
0282.04	Read developer cartridge ID	MCU:\$10 CRU:\$10
0282.05 <sup>2</sup>	Read toner cartridge ID	MCU:\$10 CRU:\$10
0282.06 <sup>3</sup>	Show print cartridge status	X:ID=90/03/01 SUMiDA-B Sim-B1
0282.07 <sup>3</sup>	Show developer cartridge status	D:ID=10:90/03/01 SUMiDA-B Sim-B1

<sup>1</sup>This direct code can be entered from the **0000** prompt, without entering the 1701 code.

<sup>2</sup>The displayed identification code should read \$10 which is the value stored in NVRAM.

<sup>3</sup>Status codes show the type and production date of the cartridge and are useful for tracking defective supplies.

(continued on next page)

### 3.1 1701 Special Function and Test Codes

**Table 3–1 (Cont.) 1701 Special Function Codes**

<b>Code</b>	<b>Definition of Function</b>	<b>Display Panel/Comment</b>
0282.08 <sup>1</sup>	Show toner status	T.ID=10:90/05/10 SUMiDA-B Sim-B1
0282.60	Set laser power	Do not change this adjustment. If any value other than \$0A is displayed, reset the \$0A factory default value.
0282.70	Set fuser temperature	Do not change this adjustment. If any value other than \$03 is displayed, reset the \$03 factory default value.
0282.80	Set scanner auto on time	See Section 10.1 for the adjustment procedure
0282.90	Set fuser power saver time	See Section 10.2 for the adjustment procedure.
0304	DC control board ROM	V03.01 S:\$00
0308	DC control board ROM test	PASS-FAIL
0900	Pages left on print drum	0019627
0901	Pages left on developer cartridge	0049740
0902	Pages left on toner supply cartridge	0005740

<sup>1</sup>This direct code can be entered from the **0000** prompt, without entering the 1701 code.

## 3.1 1701 Special Function and Test Codes

### 3.1.3 1701 Diagnostic Tests

Using the 1701 tests, you can diagnose the individual input or output devices that connect to the DC control board.

Input devices are the various sensors, switches, and thermistors. When you run a test, the DC control board monitors the input device and displays the SENSING prompt. When you manually actuate the sensor, the beeper sounds and the control panel lights up. Other input tests display only data or control panel lights, requiring no manual interaction.

Output devices consist of motors, solenoids, and high-voltage power supplies. When you run an output test, the device is turned on and off. If PASS message is displayed, the DC control board received the expected sensor signal from the device under test. To prevent device overheating, device test time is limited to 10 seconds.

**Table 3–2 1701 Test Codes**

Test Code	Display or Prompt	Definition
0100	SENSING	Top cover LVPSA interlock switch.
0101	SENSING	Feed-door sensor.
0102	SENSING	Exit door sensor.
0201	blinking	Blinks the control panel indicators.
0202	lights	Turn on the control panel indicators.
0203	blocks	Two lines of 16 solid blocks on the display panel.
0204	Beeping	Sounds the beeper.
0205	SENSING	Press any key except <input type="checkbox"/> * and all the indicators light.
0400.00	PASS	The main motor runs.
0400.01	PASS	The main motor and transfer charger <sup>1</sup> run.
0400.02	PASS	The main motor and developer charger <sup>1</sup> run.
0400.04	PASS	The main motor and main charger <sup>1</sup> run.

<sup>1</sup>The motor is tested, the charger is just turned on.

**Note:** When you see the SENSING prompt, you must manually actuate the sensor under test.

You may need the interlock cheating tool for covers open operation. The tool is part of the miscellaneous parts kit, shown in Table 8–1.

(continued on next page)

### 3.1 1701 Special Function and Test Codes

**Table 3–2 (Cont.) 1701 Test Codes**

<b>Test Code</b>	<b>Display or Prompt</b>	<b>Definition</b>
0400.05	PASS	The main motor, transfer, and charger <sup>1</sup> run.
0400.06	PASS	The main motor, developer bias, and main charger <sup>1</sup> run.
0400.07	PASS	The main motor and all HVPSA outputs <sup>1</sup> run.
0610	PASS	The scanner motor runs.
0710	SENSING	Manual bypass sensor.
0711	data	Displays size of upper cassette.
0712	data	Displays size of lower cassette.
0721	SENSING	Upper cassette empty sensor.
0722	SENSING	Lower cassette empty sensor.
0790	SENSING	Continuous beeper and all control panel indicators.
0801	Clicks	Upper feed solenoid.
0802	Clicks	Lower feed solenoid.
0803	Complete	Runs the LCIT paper feed motor if the LCIT is connected and loaded with paper. The INVALID message is displayed if the LCIT is not attached.
0804	Clicks	Refeed clutch.
0805	Clicks	Registration clutch.
0810	SENSING	Registration sensor.
0811	SENSING	Gate sensor.
0812	SENSING	Exit sensor.
0813	SENSING	Refeed sensor.
0814	SENSING	Output tray full sensor.
0815	SENSING	Offset home position sensor.
0851	Clicks	Upper turn roller clutch.
0852	Clicks	Lower turn roller clutch.

<sup>1</sup>The motor is tested, the charger is just turned on.

**Note:** When you see the *SENSING* prompt, you must manually actuate the sensor under test.

You may need the interlock cheating tool for covers open operation. The tool is part of the miscellaneous parts kit, shown in Table 8–1.

(continued on next page)

### 3.1 1701 Special Function and Test Codes

**Table 3–2 (Cont.) 1701 Test Codes**

<b>Test Code</b>	<b>Display or Prompt</b>	<b>Definition</b>
0925	SENSING	Toner empty sensor.
1000	data	This feature is not usable in a field environment. Displays fuser temperature in an unknown code.
1001	data	Fuser thermistor continuity.
1010	(Listen)	The fuser fan must accelerate to a higher speed.
1100	COMPLETE	The exit motor in forward direction at high speed.
1101	COMPLETE	The exit motor in forward direction at low speed.
1102	COMPLETE	The exit motor in reverse direction.
1103	COMPLETE	Offset motor test. Use the following procedure: <ol style="list-style-type: none"><li>1. Select and run test.</li><li>2. Open exit door.</li><li>3. Insert sheet of paper under exit sensor.</li><li>4. Close exit door.</li><li>5. Exit and offset motor will run and eject sheet of paper.</li></ol>

---

**Note:** When you see the *SENSING* prompt, you must manually actuate the sensor under test.

You may need the interlock cheating tool for covers open operation. The tool is part of the miscellaneous parts kit, shown in Table 8–1.

---

## 3.2 1948 Service Menu

### 3.2 1948 Service Menu

Before entering and using the 1948 service menu, you must select the DEC PPL3 protocol, as shown in Section 2.4.

After selecting the DEC PPL3 protocol, use the following procedure to enter and operate the 1948 service menu:

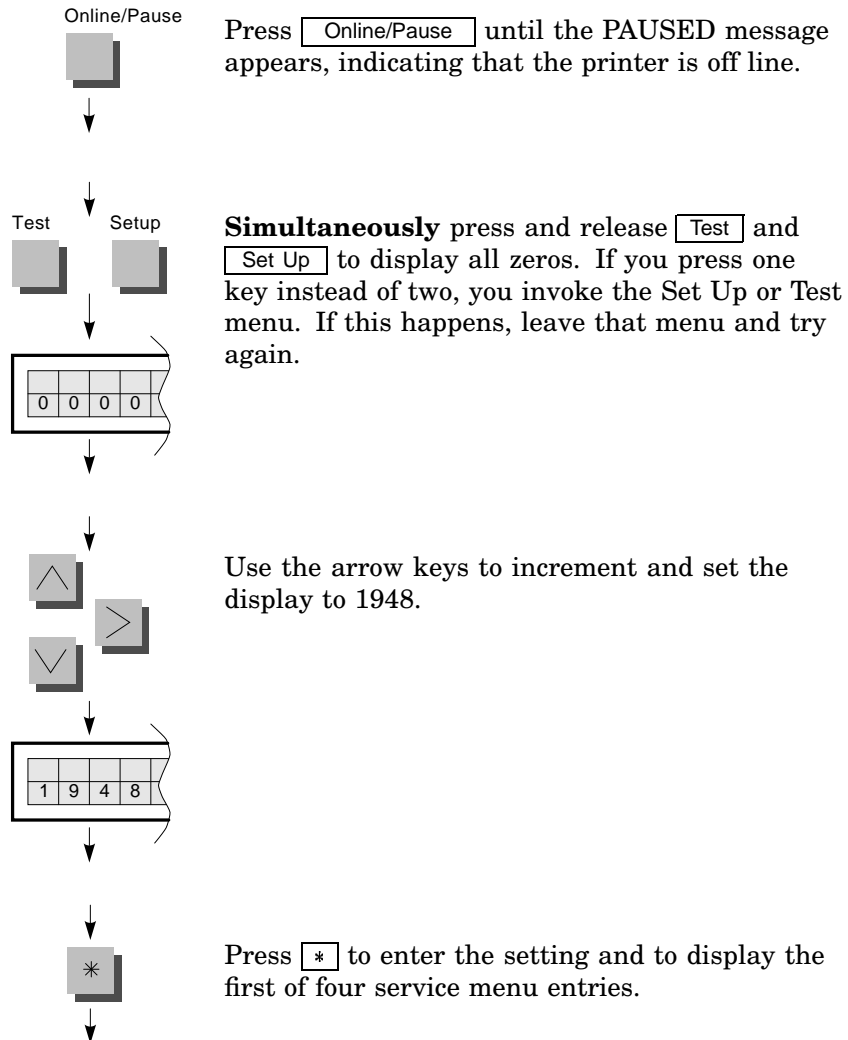

## 3.2 1948 Service Menu

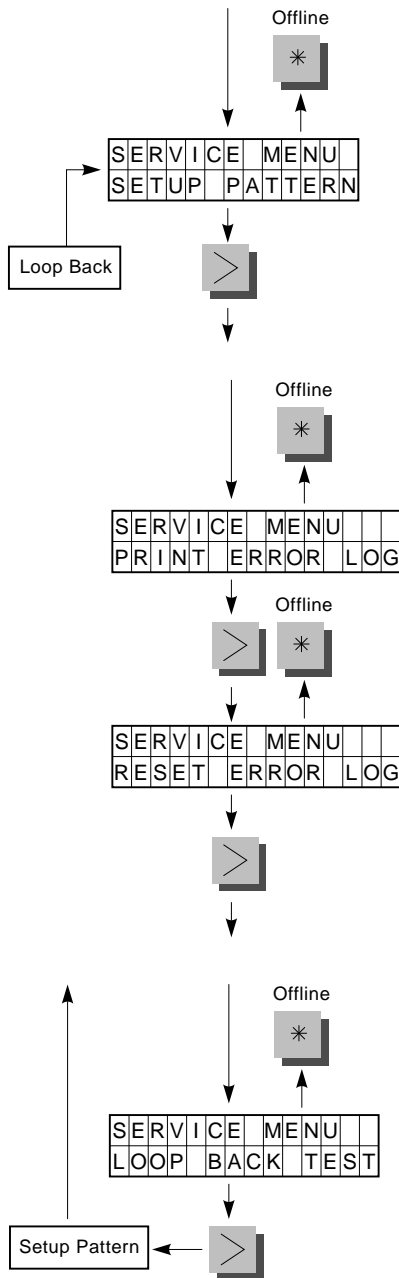

Press **>** to print the SETUP PATTERN.

Figure 3–1 is an example of the SETUP PATTERN. The SETUP PATTERN is useful for checking print quality or for a quick check of the printer.

Press **>** to go to the next service menu entry.

Press **\*** to print the error log described in Figure 3–2 or press **>** to go to the next service menu entry. The error log may print in portrait or landscape orientation, depending on the orientation of the last print job.

The error log lists all error codes and the number of times an error occurred. Turn to Section 5.3 to interpret the error codes.

Press **>** to go to the next service menu entry.

The LOOP BACK test cannot be used in the field. Special equipment is necessary. Press **>** to return to the first service menu entry (SETUP PATTERN).

### 3.2 1948 Service Menu

Figure 3-1 1948 Service Menu SETUP PATTERN

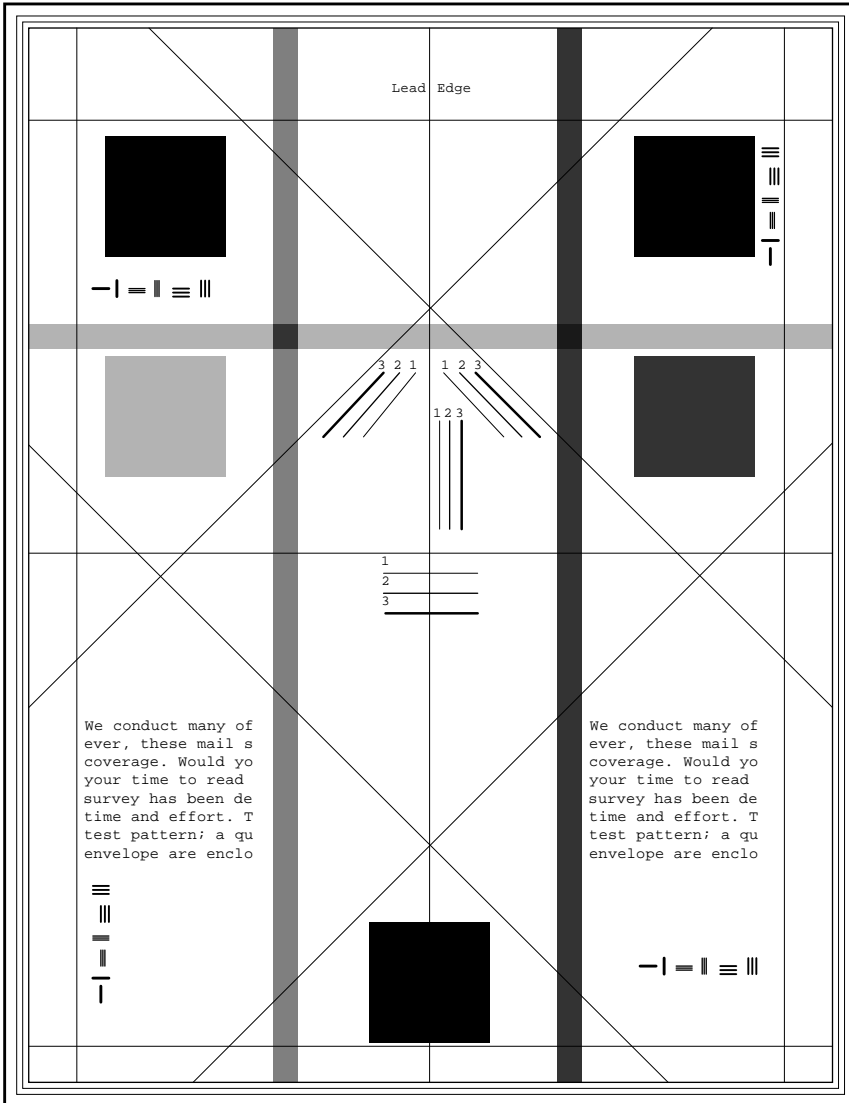

MLO-006634

## 3.2 1948 Service Menu

Figure 3-2 Error Log

Error	Meter Count	PRINTER REVOLVING ERROR LOG	
0821	1253		
0924	1253		
0103	1253		
0305	1267		
0305	1275		

Error	Occurrence	PRINTER ERROR LOG	
0103	1	1002	1433
0104		1003	1434
0105		1004	1435
0300		1005	1436
0301		1020	1437
0302		1021	1438
0305	2	1022	1439
0312		1023	1440
0313		1024	1441
0401		1025	1442
0600		1026	1443
0601		1111	1444
0700		1120	1445
0701		1401	1446
0702		1402	1447
0703		1403	1448
0705		1404	1449
0706		1405	1450
0707		1406	1451
0820		1407	1452
0821	1	1408	1453
0822		1410	1454
0823		1411	1455
0824		1412	1456
0826		1413	1457
0827		1414	1458
0830		1415	1459
0831		1416	1500
0832		1417	1502
0833		1418	1503
0834		1419	1508
0901		1420	1509
0902		1421	1511
0903		1422	1519
0904		1423	1520
0911		1424	1521
0912		1425	1523
0913		1426	1526
0914		1427	1531
0921		1428	1532
0922		1429	1533
0923		1430	1534
0924	1	1431	1535
1001		1432	

MLO-006635

## 3.3 Test Print Menu

### 3.3 Test Print Menu

From the Test Print menu, you can selectively exercise each section of the simplex and duplex paper path, and read a variety of status information.

#### Entering the Test Print menu

1. If the printer is on line, press  to display PAUSED.
2. Turn off the printer power.
3. Simultaneously press  and  and turn on the printer power. Four zeros (0000) will appear on the display.
4. Press  to enter the Test Print menu.
5. Figure 3-3 shows the Test Print menu control panel display and keys.

#### Exiting the Test Print Menu

To terminate and leave the Test Print menu, power down the printer.

Figure 3-3 Test Print Menu

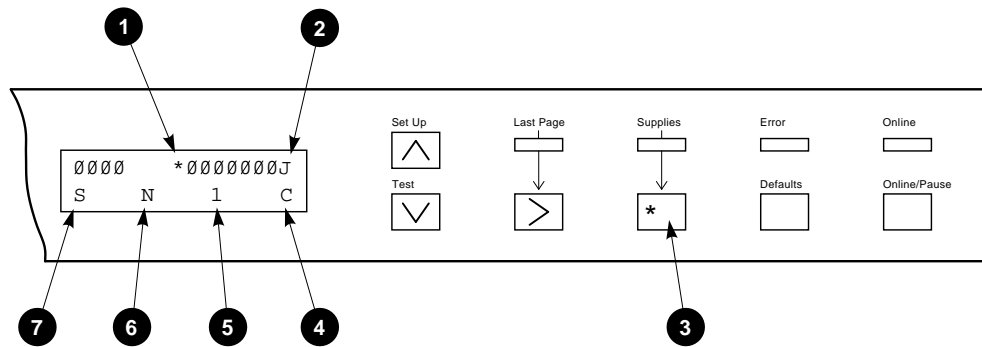

MLO-006636

**About the Test Print Menu Display** The following list refers to Figure 3-3 and describes the operation of the Test Print menu:

- 1 When an \* appears, press  to display the error message and code. The message is a short definition of the condition. For more information, look up the code in Table 5-1.

### 3.3 Test Print Menu

- ② When the printer is printing, press **Test** to step through the following informational displays. This information is also available through the 1701 special function codes, as shown in Table 3-1.
  - J = Number of test prints since start of job
  - S = Number of prints since power on
  - L = Number of prints on this printer (Life count)
  - X = Number of prints remaining on print drum
  - D = Number of prints remaining on developer cartridge
  - T = Number of prints remaining on developer cartridge
- ③ Press **\*** to start or stop the continuous feeding print job.
- ④ Press **Test** to step through the **C** ⇒ **W** ⇒ **B** test prints. Figure 3-4, shows examples of the three test patterns.
- ⑤ Press **Defaults** to change to the following feed device:
  - 1 = Upper cassette
  - 2 = Lower cassette
  - 3 = LCIT feeding
  - 4 = Manual feeding slot. Before manual feeding, you must set the sheet size by using the special function test code 0281.10, as shown in Table 3-1.
- ⑥ Press the **Online/Pause** to toggle the offset motor on and off for test printing. The N and F characters stand for no-offset or offset.
- ⑦ Press **Set Up** to toggle between simplex or duplex paper paths for test printing. The S or D characters identify the selected paper path.

## 3.3 Test Print Menu

### 3.3.1 Grid and Dusting Test Prints

Figure 3–4 shows examples of the following test patterns that are available through the test print menu:

- Grid pattern
- Dark dusting (Black)
- Light Dusting (White)

**Figure 3–4 Test Menu Patterns**

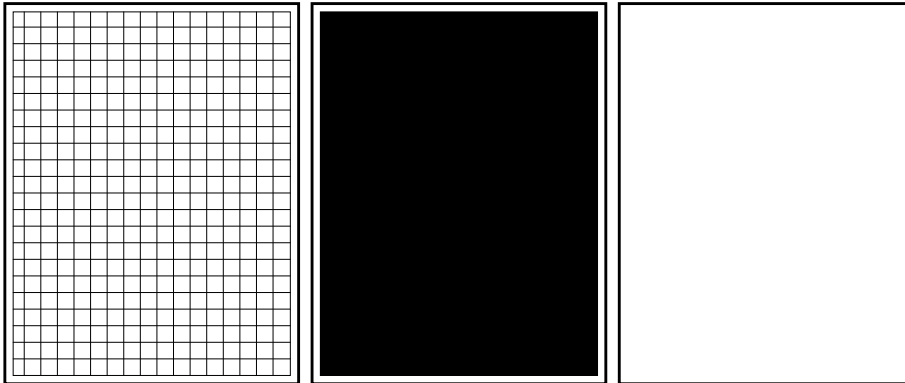

MLO-006637

## 3.4 Service Shutdown and Power-Up Procedure

Do the following before you attempt to service a DEClaser 3200 printer. If, during the procedure, the control panel hangs or an error message is displayed, go to Section 4.1.

1. Power down the printer.
2. Remove any installed font cartridges.
3. Power up the printer. You will see the self-test countdown numbers and eventually the READY message is displayed and the Online indicator lights. Figure 2–2 shows an example of the online display.
4. Press  to extinguish the Online indicator and display the Paused message. The printer is now off line.

### 3.4 Service Shutdown and Power-Up Procedure

5. Press  to enter the Set Up menu. The Protocol message will appear.
6. Press  to display the selected protocol.
7. Press  until DEC PPL3 appears.
8. Press  to select DEC PPL3. The asterisk (\*) will appear next to DEC PPL3. Unless you save the defaults, as shown in Section 2.5, the original protocol will return at power up.
9. Press  twice. On the first press, you exit the Set Up menu to the on line mode. On the second press, you go to the paused mode.



---

## Start FIP and Nonerror Code FIPs

This chapter covers the Start FIP and the nonerror code FIPs. Figure 4–1 shows the procedure that you must follow to test, isolate, and repair the DEClaser 3200 printer. The Start FIP and TCC procedure will test the printer, isolate a malfunction, and direct you to a specific FIP in Chapters 4, 5, 6, or 7. If you follow a sequence of steps to the resolution of one problem, return to the Start FIP.

**Figure 4–1 Overall Troubleshooting Flow**

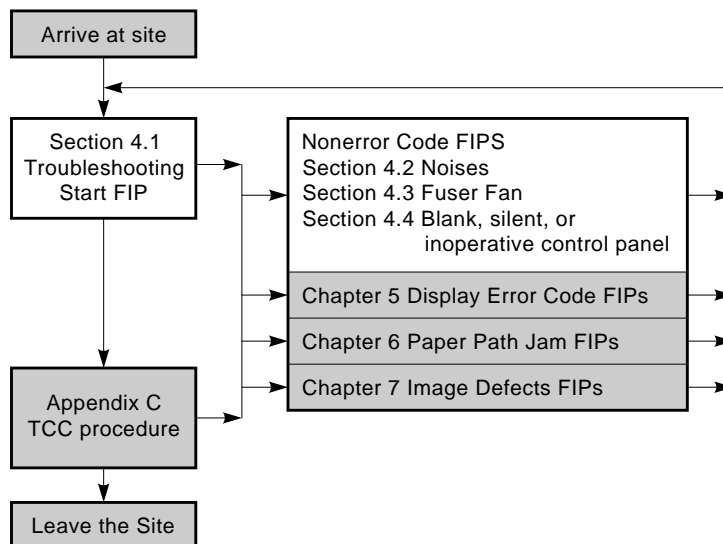

MLO-006672

## 4.1 Start FIP

### 4.1 Start FIP

Figure 4–1 shows the Start FIP flow and each step is described in Table 4–1.

**Table 4–1 Start FIP**

Step	Results and action
1. Check the temperature and humidity	The printer is designed to operate in a shirtsleeve temperature range specifically 10–32° C (50–90° F). An overheating printer causes image defects. Make sure the back, side, and all the air vents are not blocked with desk clutter.
2. Toner spills	Clean up any spilled toner and find and fix the source of the spill.
3. Prepare the printing for testing	Power down, remove the font cartridges, and select DEC PPL3 protocol, as shown in Section 3.4.
4. Power up the printer	If the printer fails to power up correctly, do one of the following: <ul style="list-style-type: none"><li>• If the display is blank, scrambled, or hung up and the indicators are inoperative or not correct, go to Section 4.4, Blank, Silent, and Inoperative Control Panel FIP.</li><li>• If the printer makes questionable noises, go to Section 4.2, Noises.</li><li>• If an error message is displayed go to Table 5–1, Error Code Master Lookup Table.</li></ul>
5. Press <input type="button" value="Online/Pause"/>	The Online indicator goes out and PAUSED appears on the display. The printer is off line.
6. Press <input type="button" value="Test"/> to enter the Test menu.	The message CONFIG SHEET appears.
7. Press <input type="button" value="*"/> to print a copy of the CONFIG SHEET, as shown in Section 2.6	If the configuration sheet prints and the image quality is good, go to the TCC procedure in Section C.1. <ul style="list-style-type: none"><li>• If an error message is displayed, go to Table 5–1, Error Code Master Lookup Table.</li><li>• If the configuration sheet is blank, black, or the image is defective, go to Section 7.1, Image Defect Lookup, to identify and fix the image defect.</li></ul>

(continued on next page)

Table 4–1 (Cont.) Start FIP

Step	Results and action
8. Perform TCC procedure, as shown in Appendix C	Keep cycling through this Start FIP and the TCC procedure until no errors occur.

## 4.2 Noises

**Description:** In normal operation the printer should not make annoying or loud noises. Appendix B lists the acoustic noise specification. In standby mode, when the printer is idle, the only moving parts are the two fans. The fuser fan slows down in standby mode. When the printer is printing, a variety of parts are moving and any one of them, if malfunctioning, can cause alarming noises.

**Caution:** *Do not lubricate the DEClaser 3200 printer unless instructed by this service guide. All gears, shaft bearings, and mechanical parts are lubricated for the life of the printer.*

**Troubleshooting:** Use the following steps to isolate and find the source of the noise:

1. **Noises in standby:** Inspect the following, if you fail to hear the fan, or hear unusual noises:
  - Turn the power off, then on.
  - Look for foreign material in the fuser fan.
  - Enter the 1010 test code to test the function of the two speed fuser fan.
  - Inspect the routing of cables around the fuser fan.
  - Inspect the video cooling fan
2. **Noises during the motor test:** Do the following if unusual or unexpected noises are heard during operation or during the 1701 test code.
  - a. Remove the top door cover, as shown in Section 9.2.
  - b. Install the interlock tool to defeat the LVPSA interlock.
 

**Warning:** *Be careful when you operate a printer with the covers removed and the interlock tool installed.*
  - c. Enter the 1701 test code 400.00, as shown in Section 3.1.3.

## 4.2 Noises

- d. If the noise occurs when the top cover is opened, inspect or swap the following:
  - Make sure the transfer/separation charger is mounted correctly and not jamming the prefuser transport roller.
  - Prefuser transport and roller
  - Registration assembly
  - Main motor assembly
- e. If the noise occurs only when the top cover is closed, inspect or swap the following gears:
  - Fuser unit drive and idler gears
  - Postfuser transport drive gears
  - Transfer/separation roller
  - Print drum cartridge
  - Developer cartridge
  - Toner Cartridge
3. Inspect the copper colored brushes that ground the shafts of the upper and lower registration and upper and lower feed rollers.
4. **Noises during printing:** Print a test sheet, as shown in Chapter 3. Do the following to find the source of noise heard while the printer is printing:
  - a. Try to isolate the noise to one or the other input cassette. If the noise is associated with one cassette, inspect its feed roller, gears, and clutches.
  - b. If the noise happens when feeding from both cassettes, inspect the following:
    - Upper and lower turn rollers, clutch, and gears. The upper turn rollers are part of the registration transport assembly.
    - Registration rollers, clutch, and gears.
  - c. If the noise only happens when duplex feeding or output stacking:
    - Inspect the refeed rollers, gears, and clutch.
    - Inspect the exit motor, gears, and rollers.

### 4.3 Fuser Fan

**Description:** A fuser fan failure can cause a number of suspicious indications: the printer might seem abnormally hot; the 1003 fuser too hot error code might be displayed; or you might notice that the fuser fan turns too slow.

When the printer is at standby, the fuser fan runs at the slow speed. When printing starts, the fan accelerates to a higher speed.

**Troubleshooting:** Test the fan by entering the 1701 test code 1010. When you press \*, the fan will accelerate. Do the following if the fan fails to turn, turns slowly, or fails to accelerate:

1. If the fan runs but fails to accelerate, replace the DC control board.
2. Manually turn the fan. Replace the fan if it fails to turn freely or sticks and binds.
3. Check the following cables and connectors:
  - 32-pin cable that connects to P30 of the DC control board and to the control panel.
  - 2-pin plug that connects the fan to the control panel.
4. Swap the following:
  - Fuser fan
  - DC control board
  - Control panel

## 4.4 Blank, Silent, and Inoperative Control Panel FIP

### 4.4 Blank, Silent, and Inoperative Control Panel FIP

**Description:** When the printer is turned on, the control panel is either blank, hung, or producing confusing indications. This is caused by a problem in the ac line power, the LVPSA, DC control board, or the control panel.

**Troubleshooting:** If the display, indicators, or keys fail to perform, try powering the printer off, then on. Perform the following procedure to fix this problem:

1. Inspect the video cooling fan and the TEST LED on the rear of the printer. The fan is powered by the 24 Vdc supply through the 2-pin P52 connector on the LVPSA. The TEST led is powered by the 5 Vdc power supply. If the fan is exhausting air and the TEST LED is lit, skip to step 3.
2. Inspect the following power line items:
  - The line cord for cuts, fraying, or damage. Do not repair a damaged line cord, replace it.
  - Both ends of the line cord are correctly attached.
  - AC power source is alive and within specification listed in Table B-6.
3. Inspect the following plugs and connectors that are shown in Figure 4-2:
  - All LVPSA connectors
  - All DC control board connectors, particularly P30 and P31
  - Control panel connectors

## 4.4 Blank, Silent, and Inoperative Control Panel FIP

Figure 4-2 Connectors

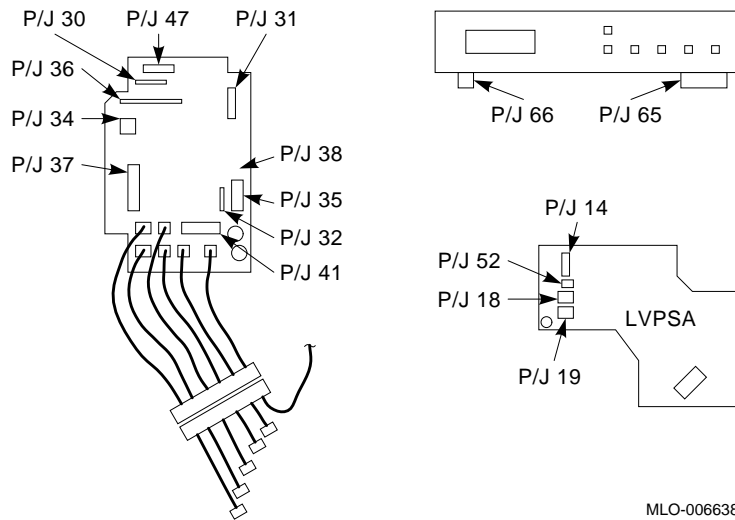

MLO-006638

4. If all connectors are all right, swap the following FRUs:
  - LVPSA
  - DC control board
  - Control panel
5. Figure A-2 shows the location of each connector in upper portion of the DEClaser 3200 printer. Inspect each connector if the printer is intermittently failing.

## 4.5 Erratic Operation

**Description:** The printer randomly stops, starts, resets, and so forth. Electrical disturbances can cause false 0305 error messages. The symptoms can be caused by a bad ground, line power problems, or a malfunctioning LVPSA.

## 4.5 Erratic Operation

### 4.5.1 Bad Grounds

Inspect the condition of all the frame grounds within printer. Make sure the following connections are tight:

- Erase board to scanner shield to printer frame green wire and ring connector grounds
- LVPSA to the printer frame green wire and ring connector ground
- Metal straps that connect the lower section to the front and exit-side of the printer

Check the installation and condition of the following spring metal grounding contacts:

- Front transfer/separation ground springs
- Top door inside print drum axle springs
- Registration pinch and pressure rollers, located at the front of the printer
- Registration transport grounding springs, located at the front of the printer

### 4.5.2 Line Power or LVPSA Problems

Erratic operation can be caused by a low-voltage power supply. Swap the LVPSA to see if the problem goes away. Look for a short or open circuit in the distribution network or in a discreet device. See Section A.5 for diagrams of the low-voltage power distribution network.

The line voltage might be too low, high, unstable, or electrically noisy. A normal DVM is all right for measuring power line voltage but other equipment and special training is necessary to thoroughly test a power line.

- Erratic operation can occur if power line voltage goes out of the range of 104–127 Vac. See Appendix E for other specifications.

**Warning:** *Be careful if using a DVM to measure the ac power line voltage. There is a shock and fire hazard.*

The DEClaser 3200 printer is reasonably tolerant of power line noise. Noise can be generated by other equipment the shares line power. Motors, welding equipment, and other sorts of electrical devices can upset the operation of the printer.

- Try moving the printer to another power line plug in a different part of the building.

### 4.5.3 High-Voltage Arcing

Badly connected green ground wires, spring metal contacts, and frame metal assembly straps can create electrical interference that effects and upsets the operation of the DC or video control boards. The control panel may flash and blank out, or the 0305 error message is erroneously displayed.

- Use the following procedure to test for high-voltage arcing:
  - a. Remove the top door cover, as shown in Section 9.2.
  - b. Install the interlock tool (See Table D-2).
  - c. Enter the 1701 test code 0400.07, as shown in Section 3.1.1. This runs the main motor and all HVPSA outputs.
  - d. Look and listen for arcing in all the high-voltage cables and connectors. It might be easier to see if you turn down the lights.
- Check the top door connectors that connect the HVPSA to the print cartridge. Fix or replace any damaged parts.
- Check the front spring connector on the erase board for damage, bending, or pitting. This contact carries the primary charge current.
- Remove the transfer/separation charger. Print several copies of the grid test pattern, which will print blank (SeeSection 3.3 ). If the erratic behavior ceases, replace the transfer/separation charger.



---

## Display Error Code FIPs

As Figure 5–1 shows, this chapter includes Table 5–1, Error Code Master Lookup Table and contains the fault isolation procedures (FIPs) that are keyed to the display panel error codes. Figure 5–1 shows how Chapter 5 fits into the overall troubleshooting flow. If you follow a sequence of steps to fix one problem, return to Section 4.1, Start FIP.

**Figure 5–1 Overall Troubleshooting Flow**

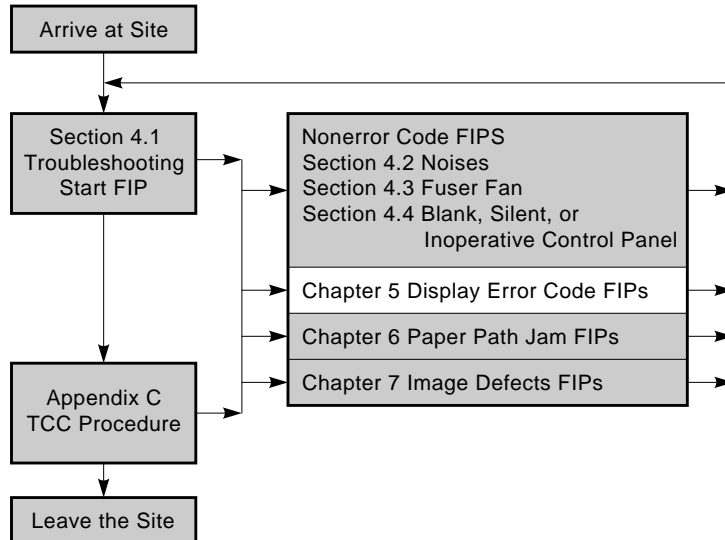

MLO-007644

## 5.1 Error Code FIPs and Messages

### 5.1 Error Code FIPs and Messages

Figure 5–2 shows an example of an error message and code that are displayed on the control panel display. Table 5–1 lists all the error messages and codes. For troubleshooting information, turn to the section listed under the full description column.

**Figure 5–2 Error Message and Code Display**

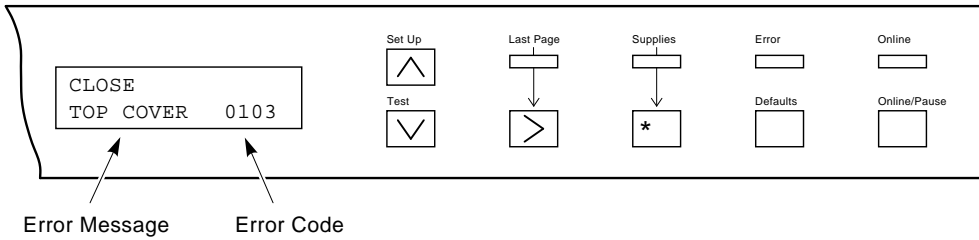

## 5.1 Error Code FIPs and Messages

**Table 5–1 Error Code Master Lookup Table**

<b>Display Code</b>	<b>Full Description</b>	<b>Brief Definition</b>
0103 <sup>1</sup>	Section 5.2	Top cover or door is open.
0104 <sup>1</sup>	Section 5.3	The left cover or exit side door is open.
0105 <sup>1</sup>	Section 5.4	The right cover or feed side door is open.
0300 <sup>2</sup>	Section 5.5	DC control board RAM test failure.
0301 <sup>2</sup>	Section 5.5	DC control board checksum failure.
0302 <sup>2</sup>	Section 5.5	DC control board microprocessor failure.
0305 <sup>2</sup>	Section 5.6	DC to video control board connection failure.
0312 <sup>2</sup>	Section 5.7	DC control board NVRAM or PROM failure.
0313		
0401 <sup>2</sup>	Section 5.8	Main motor failure.
0600 <sup>2</sup>	Section 5.9	Start of scan (beam detect) is not received.
0601		Start of scan is late.
0700 <sup>1</sup>	Section 5.10	No paper in the bypass transport.
0701 <sup>1</sup>	Section 5.11	Upper paper out sensor detects empty cassette.
0702 <sup>1</sup>	Section 5.12	Lower paper out sensor detects empty cassette.
0703 <sup>1</sup>	Section 5.13	LCIT paper out sensor detects empty LCIT.
0705 <sup>1</sup>	Section 5.14	Upper cassette is missing or not fully installed.
0706 <sup>1</sup>	Section 5.15	Lower cassette is missing or not fully installed.
0707 <sup>1</sup>	Section 5.16	LCIT is missing or not fully installed.
0820 <sup>1</sup>	Section 6.2	Registration sensor jam, leading edge jam, or feeding failure
0821		
0822		
0823		
0824		
0826 <sup>1</sup>	Section 6.3	Duplex refeed leading edge jam.
0827 <sup>1</sup>	Section 6.4	Duplex refeed trailing edge jam.

<sup>1</sup>Printing stops, unless failover is selected, until operator attends to the offending problem. To clear this error, a door sensor needs to actuate. If failover is successful, the Supplies indicator will light and printing will continue. Press  to display the Supplies menu, which is not mentioned elsewhere in the book.

<sup>2</sup>Fatal error that occurs at power on and disables printer.

(continued on next page)

## 5.1 Error Code FIPs and Messages

**Table 5–1 (Cont.) Error Code Master Lookup Table**

<b>Display Code</b>	<b>Full Description</b>	<b>Brief Definition</b>
0830 <sup>1</sup> 0831 0832 0833 0834	Section 6.5	Registration trailing edge jams
0901 <sup>3</sup> 0902 <sup>1</sup> 0903 <sup>1</sup> 0904 <sup>1</sup>	Section 5.17	Print drum cartridge end-of-life warning. Print drum cartridge end of life. Incompatible print drum installed. Print drum cartridge is not installed.
0911 <sup>1</sup> 0912	Section 5.18	Developer cartridge end-of-life warning. Developer cartridge end of life.
0913 <sup>1</sup> 0914	Section 5.17	Incompatible developer cartridge installed. Developer cartridge write failure.
0921 <sup>3</sup> 0922 <sup>1</sup> 0923 <sup>1</sup> 0924 <sup>1</sup>	Section 5.19	Toner low warning. Toner cartridge end of life. Incompatible toner cartridge installed. No toner cartridge installed.
1001 <sup>2</sup> 1002 <sup>2</sup> 1003 <sup>2</sup> 1004 <sup>2</sup> 1005 <sup>2</sup>	Section 5.20	Fuser failure. Thermistor continuity failure (open circuit). Fuser temperature too low. Fuser temperature too high. Fuser heater has been on too long.
1020 <sup>1</sup> 1021 1022 1023 1024	Section 6.6	Fuser jam when feeding from bypass slot. Fuser jam when feeding from upper cassette. Fuser jam when feeding from lower cassette. Fuser jam when feeding from LCIT. Fuser jam when feeding from duplex refeed.
1025 <sup>1</sup>	Section 6.7	Exit leading edge jam.
1026 <sup>1</sup>	Section 6.8	Exit trailing edge jam.
1111 <sup>1</sup>	Section 5.21	Output tray is full.
1120 <sup>1</sup>	Section 5.22	Offset home position sensor failure.

<sup>1</sup>Printing stops, unless failover is selected, until operator attends to the offending problem. To clear this error, a door sensor needs to actuate. If failover is successful, the Supplies indicator will light and printing will continue. Press \* to display the Supplies menu, which is not mentioned elsewhere in the book.

<sup>2</sup>Fatal error that occurs at power on and disables printer.

<sup>3</sup>Printing continues but will soon stop. If the Supplies indicator lights, press \* to display error.

(continued on next page)

## 5.1 Error Code FIPs and Messages

**Table 5–1 (Cont.) Error Code Master Lookup Table**

Display Code	Full Description	Brief Definition
1400 1401 1402 1403 1404 1405 1406 1407	Section 5.23	Communication error indicates an interface problem with the host system. If printer halts, press <input type="button" value="*"/> to display next error or to continue.
1500 <sup>4</sup>	Section 5.24	Font cartridge error.
1502 <sup>4</sup> 1503	Section 5.25	Memory board (SIM) error.
1508 <sup>4</sup>	Section 5.26	Coprocessor error.
1509 <sup>4</sup>	Section 5.27	NVRAM error.
1511 1519		Error codes for future options.
1520 <sup>2</sup>	Section 5.28	Call for service.
1521 <sup>4</sup> 1523	Section 5.29	PDL option board error.
1526 <sup>2</sup>	Section 5.30	Video control board error.

<sup>2</sup>Fatal error that occurs at power on and disables printer.

<sup>4</sup>Nonfatal error that occurs at power on and can partially disable the printer. Press  or  to continue.

## 5.2 103, Close Top Cover

### 5.2 103, Close Top Cover

**Description:** This error appears when the tang on the top cover fails to depress the interlock switch. See ❶, Figure 5–3. The interlock switch, part of the LVPSA assembly, is a mechanical double pole switch that, when closed, connects the +24 Vdc power to the main motor and signals the DC control board.

**Troubleshooting:** Test the operation of the top cover interlock switch and circuit by entering the 1701 code 0100, as shown in Section 3.1.3. The control panel lights and beeps when you open and close the top cover or manually depress the interlock switch. Go to one of the following steps:

- The top cover interlock circuit works correctly when the switch is manually depressed, but has problems when the cover is opened or closed. Inspect the following for damage or misoperation:
  1. Open and close the top cover, make sure the tang fully depresses the interlock switch.
  2. If the top door cover is damaged or not mounted correctly, repair or replace it.
- The top cover interlock circuit fails to operate when the switch is manually pressed. Perform the following steps:
  1. Inspect the 12-wire cable that connects J14 on the LVPSA to J31 on the DC control board. Pin-8 of that cable carries the 24V door open signal. Look for misconnection or damage.
  2. Swap the LVPSA.
  3. Swap the DC control board.

Figure 5-3 103 Error Code

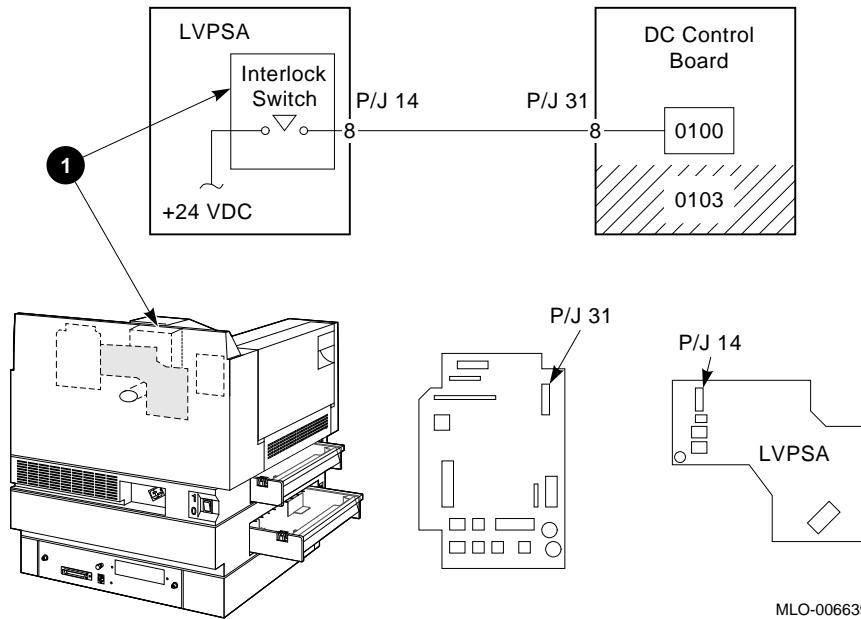

### 5.3 104, Close Left Cover (Exit Door)

**Description:** The left cover is also referred to as the exit door. The exit-door sensor is a magnetic switch that mounts on the rear bulkhead of the exit area. Figure 5-4 shows the wiring diagram. The switch is actuated by the permanent magnet that is mounted on the exit door.

**Troubleshooting:** Test the operation of the exit-door switch and circuit. Enter 0102 to invoke the 1701 test, as shown in Section 3.1.3. To test the switch and circuit, open and close the exit door or pass a magnet close to the sensor. The contacts close when the magnet is next to the switch. Go to one of the following steps:

- If a magnet can operate the exit-door sensor circuit, inspect the the following:
  1. Mechanical operation of the exit door
  2. Mounting and condition of the permanent magnet

### 5.3 104, Close Left Cover (Exit Door)

- If the sensor circuit fails to work, do the following:
  1. Inspect 2-pin plug connecting the sensor to PJ57 on the driver board. Pin-1 toggles high (5Vdc) when the door opens and toggles low (ground) when the door closes.
  2. Inspect the 19-pin plugs that connect P56 of the driver board to P57 of the DC control board. The door open signal can be measured on pin-14 of that cable.
  3. Swap the sensor.
  4. Swap the driver board.
  5. Swap the DC control board.

Figure 5-4 104 Error Code

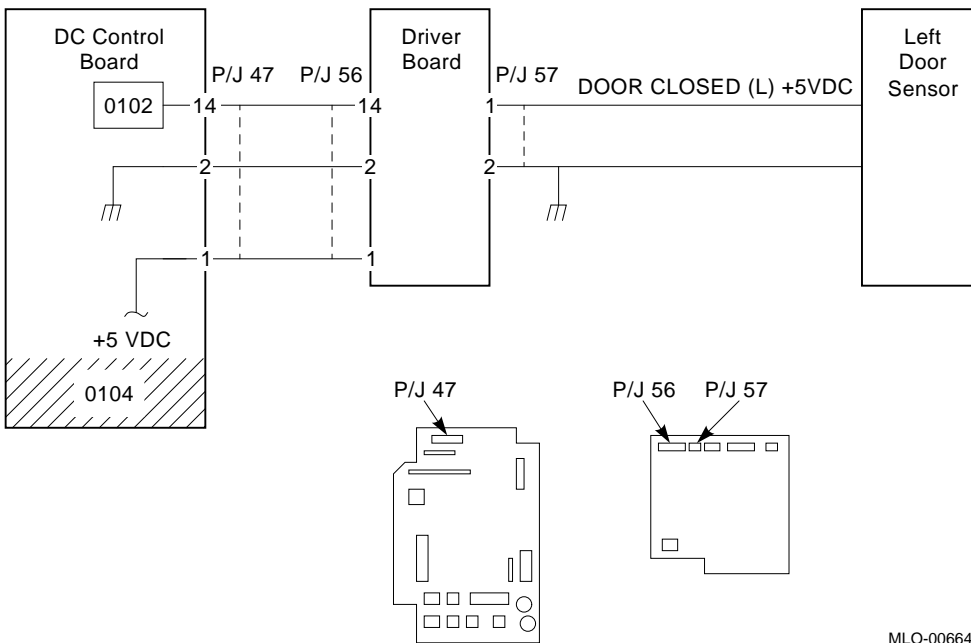

### 5.4 105, Close Right Cover (Feed Door)

**Description:** The right cover is also referred to as the feed door. When the feed door is closed, a magnet on the door actuates the feed door sensor and signals the DC control board. The sensor is a mechanical switch that is closed when actuated. Figure 5-5 shows the wiring diagram.

**Troubleshooting:** Test the operation of the feed-door sensor circuit. Enter 0101 to invoke the 1701 test, as shown in Section 3.1.3. To test the switch and circuit, open and close the door or pass a magnet close to the sensor. The contacts close when the magnet is next to the switch. Go to one of the following steps:

- If a magnet can operate the feed-door sensor circuit, inspect the following:
  1. Mechanical operation of the feeding door
  2. Mounting and condition of the magnet and sensor assembly
- If the circuit fails to work, do the following:
  1. Inspect the 16-pin that connects the DC control board to the wire harness.
  2. Inspect the connection and condition of the 2-pin plug that connects the feed-door sensor from the wire harness.
  3. Swap the feed-door sensor.
  4. Swap the DC control board.
  5. Swap the LVPSA.

## 5.4 105, Close Right Cover (Feed Door)

Figure 5-5 105 Error Code

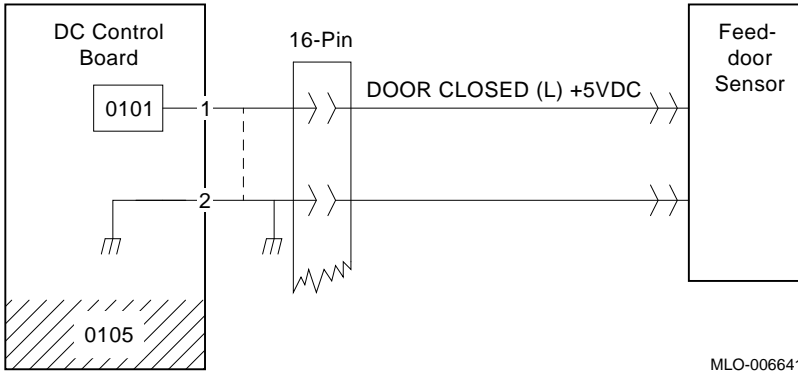

MLO-006641

## 5.5 0300–0302 CALL SERVICE

**Description:** These fault codes are displayed when the power-up test detects an error in one of the following DC control board components:

- 0300 indicates a RAM memory checksum error.
- 0301 indicates a ROM checksum error
- 0302 indicates a microprocessor error

**Troubleshooting:** With the exception of the page count ROM, you should not replace individual components of the DC control board. Do the following when one of these codes is displayed:

1. If 0301 is displayed, inspect and reseat the U13 and U14 ROMs on the DC control board. Look for bent or broken pins.
2. Replace the DC control board.

## 5.6 0305 CALL SERVICE

**Description:** This fault code is displayed by the power up test and indicates a communication failure between the DC and video control boards. **A secondary cause** might be the high-voltage arcing caused by bad grounds or a malfunctioning HVPSA.

**Troubleshooting:** The TEST LED (see ❶ on Figure 5–6) stays on for about 12 seconds while executing the power up diagnostics. The more installed memory, the longer the LED is on. If the diagnostics are successful, the LED turns off.

**Figure 5–6 Rear Error LED**

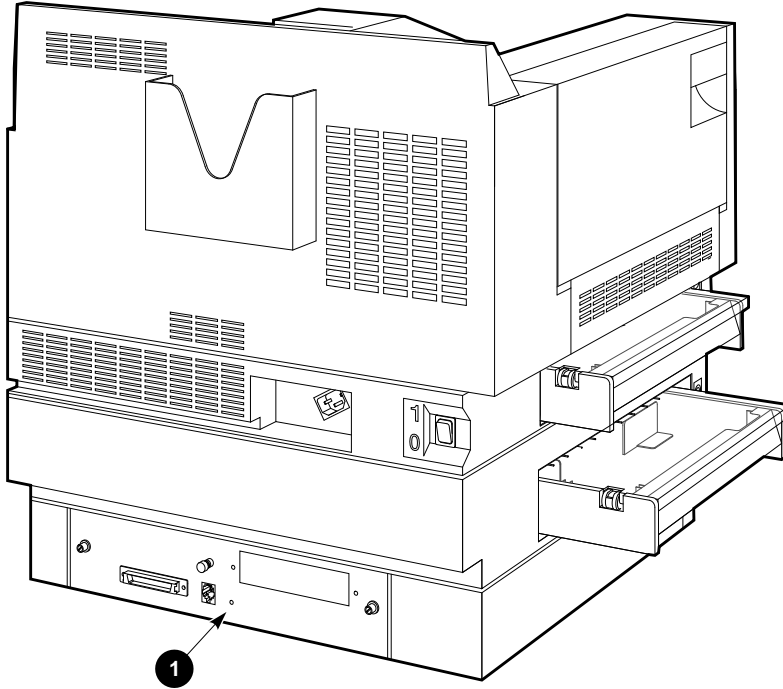

MLO-006642

1. Watch the LED and turn on the printer power.
2. If LED never comes on, do the following:
  - a. Inspect the 2-wire cables that connect the 4-pin, P/J7 connector on the video control board to the 2-pin, P57 and P18 connectors, on the LVPSA. The cables supply 5 Vdc to the video control board.
  - b. Swap the LVPSA.
  - c. Remove any installed SIMs, PDL, and coprocessor boards.

## 5.6 0305 CALL SERVICE

- d. If the printer powers up all right, install each board one at a time to find the offending board.
- e. Swap the video control board
3. If the LED lights for 3–4 seconds, then goes out, replace the video control board.
4. If the LED lights for 1.3–2 minutes, (the amount of expansion memory determines the LED on time) then starts flashing, do the following:
  - Inspect or swap the 26-pin cable harness that connects P37 on the DC control board to P/J2 on the video control board.
  - Swap the DC control board.
  - Swap the video control board.
5. Do the following if the action of the LED is ambiguous or fails to resolve the problem:
  - a. Inspect the 26-pin cable harness that connects P37 on the DC control board to P/J2 on the video control board. Look for misconnection or damage.
  - b. Inspect the high-voltage connectors that connect the transfer/separation charger to the HVPSA.  
  
Inspect the spring contacts that ground the transfer/separation supply. Fix any damage that you find. This type of malfunction generally causes intermittent 0305 errors.
  - c. Swap the DC control board.
  - d. Swap the video control board.
  - e. Swap the cable that connects the DC to video control boards.
  - f. Swap the LVPSA.

## 5.7 0312–0313 CALL SERVICE

**Description:** This message is displayed if the power-up self-test detects a checksum error in one of the following memory devices of the DC control board. See Figure 5–7 for the location of the devices.

- 0312 is displayed if a NVRAM ❶ error is found.
- 0313 is displayed if a EPROM ❷ error is found.

**Troubleshooting:** Perform the following procedure:

1. Reseat and inspect the pins of all socket mounted ICs on the DC control board.
2. Replace the DC control board.

Figure 5–7 DC control board ICs

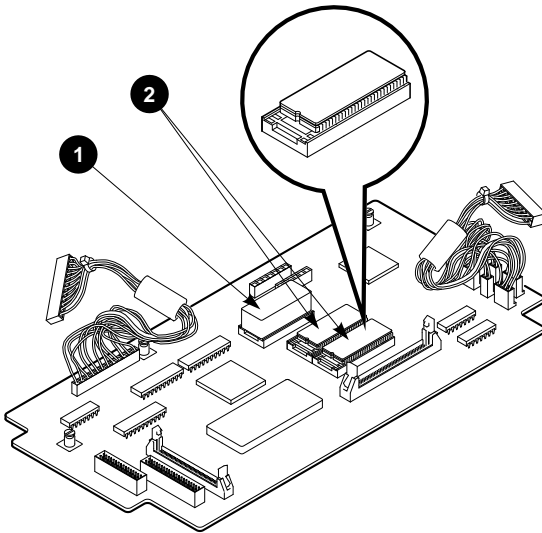

MLO-006649

## 5.8 0401 CALL SERVICE

### 5.8 0401 CALL SERVICE

**Description:** This message is displayed when the speed of the main motor is incorrect. (Shown in Figure 5–8) The motor control board measures the motor speed and transmits a signal to the DC control board. A drop in motor speed can be caused by excessive drag in the driven load, a malfunctioning motor, or electronic drive circuit.

**Troubleshooting:** Test the operation of the main motor. Enter the 0400.00 code into the 1701 test. You should hear and see the main motor running, and eventually a PASS or FAIL message is displayed. Make sure the top cover interlock switch is depressed and working properly, as shown in Section 5.2. Perform the following steps:

1. Inspect the 7-wire cable that connects from P35 on the DC control board to the motor control board.
2. Use the following procedure to inspect the condition of the main motor load gears:

**Warning:** *Turn off the ac power before performing the next step.*

The cooling fan that is attached to the rear of the main motor armature can be used to manually turn the main motor. Turn off the ac line power and manually turn the cooling fan through several revolutions. The motor and attached gear train must move easily and freely with no binding or sticking.

If resistance is felt, inspect all gears, rollers, and clutches for evidence of damage. Fix or replace any defective components.

3. Swap the following components:
  - DC control board
  - LVPSA
  - Main motor assembly

## 5.8 0401 CALL SERVICE

Figure 5-8 Main Motor Location

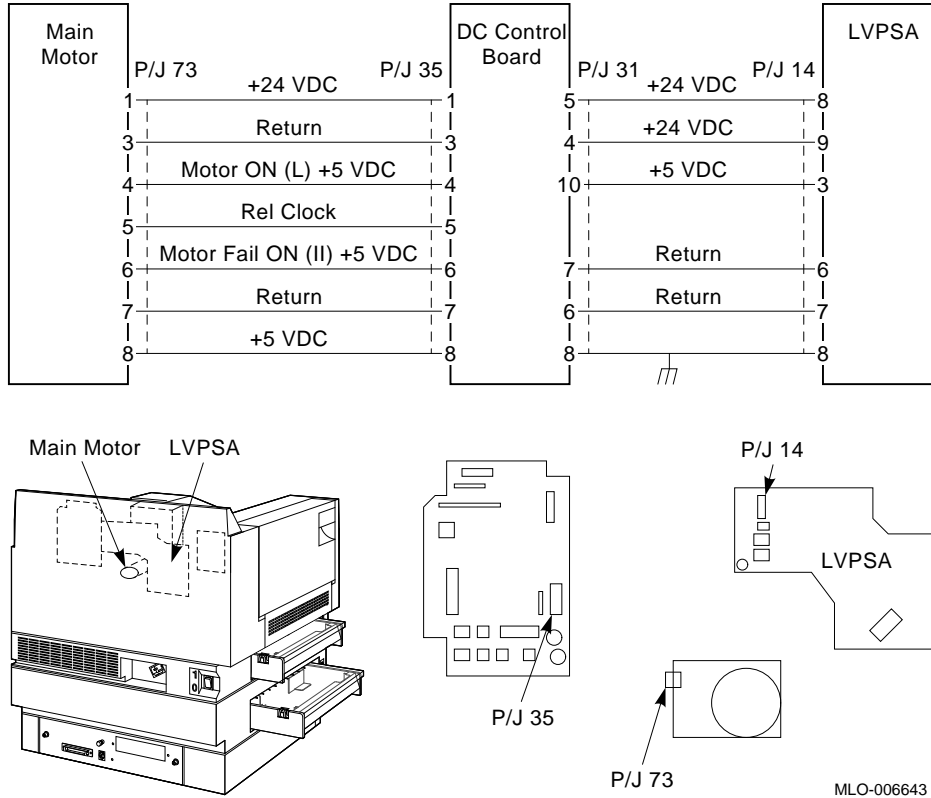

## 5.9 0600/0601 CALL SERVICE

**Description:** A 0600 or 0601 error code indicates that the Start-of-scan (SOS) signal is late (600) or was never (610) received by the DC control board. The SOS signal is generated when the laser beam is scanned across the SOS detector. A malfunction of the scanner motor, laser, or electronics causes this error.

Figure 5-9 shows the power supply and scanner motor control signal for the scanner assembly. When the top door is closed the scanner interlock switch is closed. When closed, +15 Vdc is supplied to the laser diode.

## 5.9 0600/0601 CALL SERVICE

Figure 5-9 Scanner Circuit

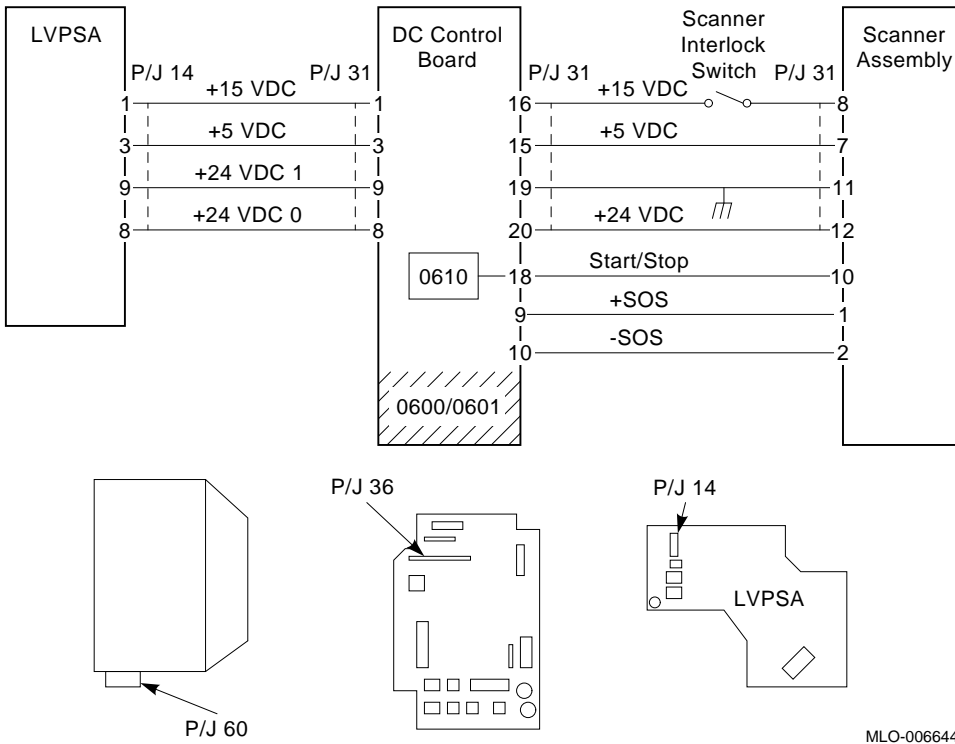

**Troubleshooting:** To test the SOS signal, print a test pattern from the Test Print menu, as shown in Section 3.3. If the test pattern prints with no image defects, the test is successful.

Test the scanner motor by entering the 1701 code 0610 to invoke the scanner motor test, as shown in Section 3.1.3. When entered, the motor should run for 20 seconds and then display a Pass or Fail message. The top cover interlock switch must be depressed to enable the +5 and +24 Vdc LVPSA power.

1. Inspect the following cables and connectors:
  - 12-pin plug that connects the scanning assembly to the wire harness
  - Wire harness and connectors running between the scanning assembly and P36 on the DC control board
  - 2-pin plug that connects to the scanner interlock switch

2. If the motor test mentioned above fails, swap the scanner interlock switch.
3. Swap the following components:
  - DC control board
  - Scanner assembly
  - LVPSA

## 5.10 0700 ADD PAPER TO MANUAL

**Description:** This error code is displayed during manual feeding and prompts you to load paper into the manual slot. When the registration sensor detects the leading edge of the sheet, the printer will grab it and print the sheet.

**Troubleshooting:** Suspect the registration or bypass sensor. Test both sensors by entering the 1701 test codes, 0710 for the bypass and 0810 for the registration. Perform the following steps to fix a problem.

**Figure 5–10 700 Error**

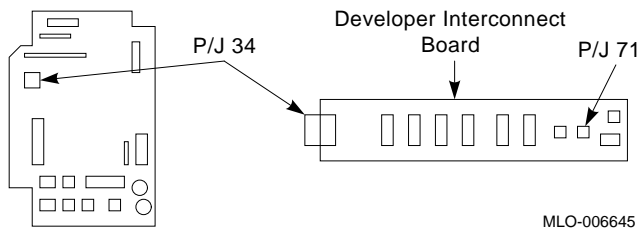

1. Refer to Figure 5–10 and inspect the following for damage, misconnection, or mechanical damage:
  - 2-pin, P/J71 plug connecting to P/J71 on the developer interconnect board
  - 10-pin jack that connects to P34 on the DC control board. Pin three of P34 goes high when the sensor is actuated.
  - Manual feed sensor linkage
  - Manual feed sensor mounting
2. Swap the following components:
  - Manual feed sensor
  - Developer interconnect board

## 5.10 0700 ADD PAPER TO MANUAL

- DC control board

## 5.11 0701 ADD PAPER TO TRAY 1

**Description:** This code and text is displayed when the upper cassette-empty sensor finds that the upper cassette is empty. A spring underneath the cassette elevator lifts the stack into the sensor arm. The sensor connects through the upper size-sensing sensor assembly to 4-pin, P/J33 on the DC control board. Figure 5–11 shows location of P/J33.

**Figure 5–11 701 Error**

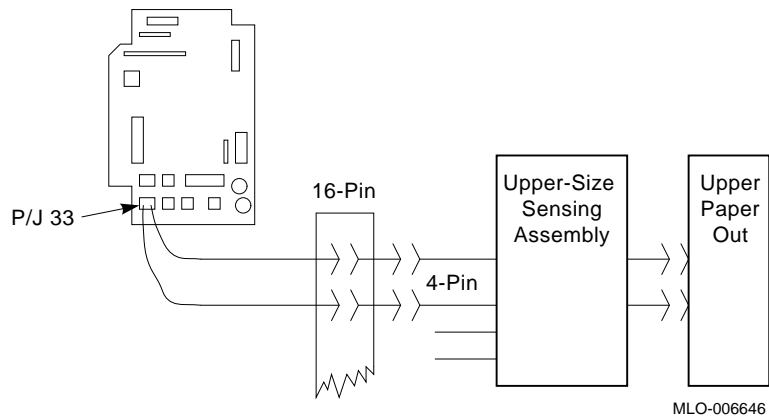

**Troubleshooting:** Test the upper paper out sensor by entering the 1701 test code 0721, as shown in Section 3.1.3. When the test is sensing, open the feeding side door and manually actuate the upper feed sensor. Perform the following procedure:

1. Make sure the cassette is fully pushed in.
2. Verify the condition of the cassette by swapping cassettes from tray 2 to tray 1.
3. Inspect the following for damage, misconnection, or mechanical failure:
  - Operation of the cassette elevator
  - Upper paper out sensor mounting
  - Upper paper out sensor linkage
  - 2-pin plug that connects to the upper paper out sensor

## 5.11 0701 ADD PAPER TO TRAY 1

- 4-pin plug that connects to P/J33 (see Figure 5–11) on the DC control board. Pin three of P/J33 goes high when the sensor is actuated.
4. Swap the following:
- DC control board
  - Upper paper out sensor
  - Upper cassette-size sensor assembly

## 5.12 0702 ADD PAPER TO TRAY 2

**Description:** This code and text is displayed when the lower cassette-empty sensor finds the lower cassette empty. A spring underneath the cassette elevator lifts the stack into the sensor arm. The sensor connects through the lower size-sensing sensor assembly to 4-pin, P/J43 on the DC control board, as shown on Figure 5–12.

**Figure 5–12 702 Error**

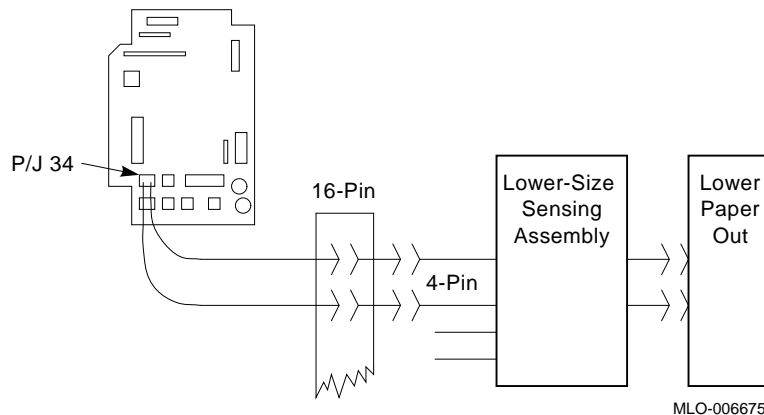

**Troubleshooting:** Test the upper paper out sensor by entering the 1701 test code 0722, as shown in Section 3.1.3. When the test is sensing, open the feeding side door and manually actuate the lower feed sensor. Perform the following procedure:

1. Make sure the lower cassette is fully pushed in.
2. Verify the condition of the cassette by swapping cassettes from tray 2 to tray 1.

## 5.12 0702 ADD PAPER TO TRAY 2

3. Inspect the following for damage, misconnection, or mechanical failure:
  - Operation of the cassette elevator
  - Lower paper out sensor mounting
  - Lower paper out sensor linkage
  - 2-pin plug that connects to the lower paper out sensor
  - 4-pin plug that connects to P/J44 (see Figure 5–11) on the DC control board. Pin three of P/J44 goes high when the sensor is actuated.
4. Swap the following:
  1. DC control board
  2. Lower paper out sensor
  3. Lower cassette-size sensor assembly

## 5.13 0703 ADD PAPER TO FEEDER

**Description:** This error message is displayed when the LCIT paper out sensor finds that the LCIT is empty. Many LCIT malfunctions can cause this error.

**Troubleshooting:** Before performing the following FIP, make sure the printer is in good working order. Select a cassette and feed test prints from it.

1. Make sure the LCIT is plugged into the printer and the lead-in cable is in good condition.
2. Run the elevator down to check the operation of the LCIT. If this test fails, go to Chapter 11 to diagnose the LCIT.
3. Test the operation of the paper out sensor linkage, sensor/switch, and circuit. Open the LCIT door and manually move the sensor linkage up and down while watching the control panel for the following:
  - Linkage up = error message clears
  - Linkage down = error message appears
  - If the sensor linkage is stiff or fails to move, remove the LCIT front and rear side covers and fix.
  - The test fails if the control panel does not change.

## 5.13 0703 ADD PAPER TO FEEDER

4. If the test fails, do the following:
  - a. Make sure the paper out sensor is plugged into the 2-pin connector P/J6 on the LCIT control board.
  - b. Swap the following:
    - LCIT control board
    - DC control board
    - Paper out switch

## 5.14 0705 INSERT TRAY 1

**Description:** This error code and text are displayed when the upper size-sensing sensor fails to detect the magnets of the installed cassette. Figure 5–13 shows the wiring diagram. See Section 1.3.3 for more information about the cassette size-sensing circuits.

**Troubleshooting:** Test the size-sensing switches by entering the 1701 test code 0711. The control panel lights up when a cassette is inserted. If the cassette fails to activate the switches, pass a magnet over the sensor pack. Perform the following steps to fix this problem:

1. Make sure the cassette has the correct magnets installed, as shown in Table 6–2.
2. Verify the condition of the cassette by swapping cassettes from tray 1 to tray 2.
3. Make sure the 4-pin plug that connects to P/J33 of the DC control board is securely connected. Whenever any tray 1 cassette is installed, the voltage between ground and pin four of P/J33 (see Figure 5–11) rises from zero to some value less than 5 Vdc.
4. Swap the following:
  - DC control board
  - Upper size-sensing assembly

## 5.14 0705 INSERT TRAY 1

Figure 5–13 Upper and Lower Size-sensing Switches

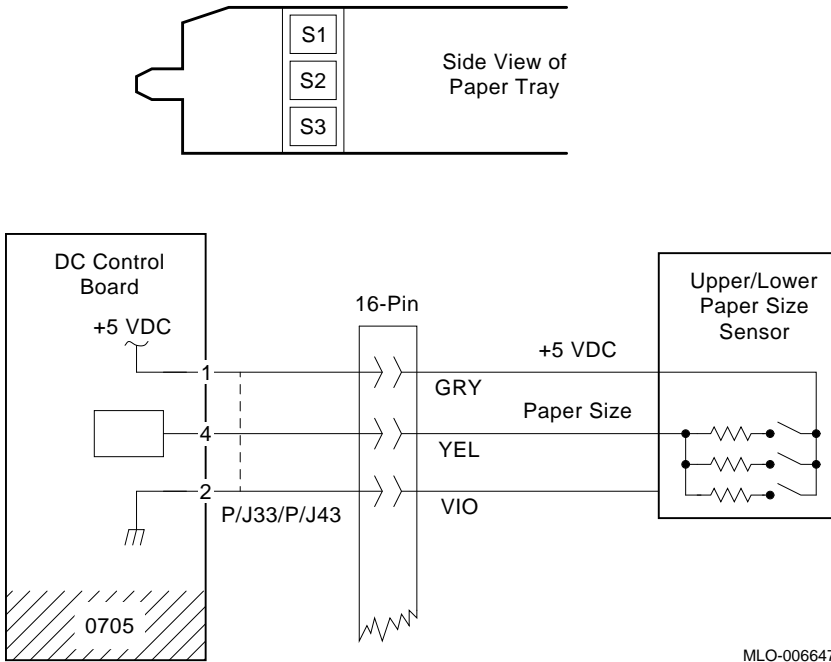

MLO-006647

## 5.15 0706 INSERT TRAY 2

**Description:** This error code and text are displayed when the lower size-sensing sensor fails to detect the magnets of the installed cassette. Figure 5–13 shows the wiring diagram. See Section 1.3.3 for more information about the cassette size-sensing circuits.

**Troubleshooting:** Test the size-sensing switches by entering the 1701 test code 0712. The control panel lights up when a cassette is inserted. If the cassette fails to activate the switches, wave a magnet over the sensor pack. Perform the following steps to fix this problem:

1. Make sure the cassette has the correct magnets installed, as shown in Table 6–2.
2. Verify the condition of the cassette by swapping cassettes from tray 2 to tray 1.

## 5.15 0706 INSERT TRAY 2

3. Make sure the 4-pin plug that connects to P/J43 (see Figure 5–11) of the DC control board is securely connected. Whenever any tray 2 cassette is installed, the voltage between ground and pin four of P/J43 rises from zero to some value less than 5 Vdc.
4. Swap the following:
  - DC control board
  - Lower size-sensing assembly

## 5.16 0707 INSERT AUXILIARY

**Description:** This message is displayed when the DC control board detects low voltage on P/J41, pin-7. Figure 5–14 shows the wiring diagram. If the voltage is greater than 15.7, the printer will configure itself for an LCIT.

**Troubleshooting:** Before performing the following FIP, make sure the printer is in good working order. Select a cassette and feed test prints from it.

1. Test the operation of the LCIT by running the elevator up and down. If the test fails, go to Chapter 11 to diagnose the LCIT.
2. Inspect the condition of the following cables and connectors.
  - a. 8-pin modular jack (P90) that connects the LCIT to the DC control board
  - b. 6-pin plug that connects to the LCIT control board
  - c. 8-pin plug that connects to P/J41 of the DC control board

## 5.16 0707 INSERT AUXILIARY

Figure 5–14 707 Error

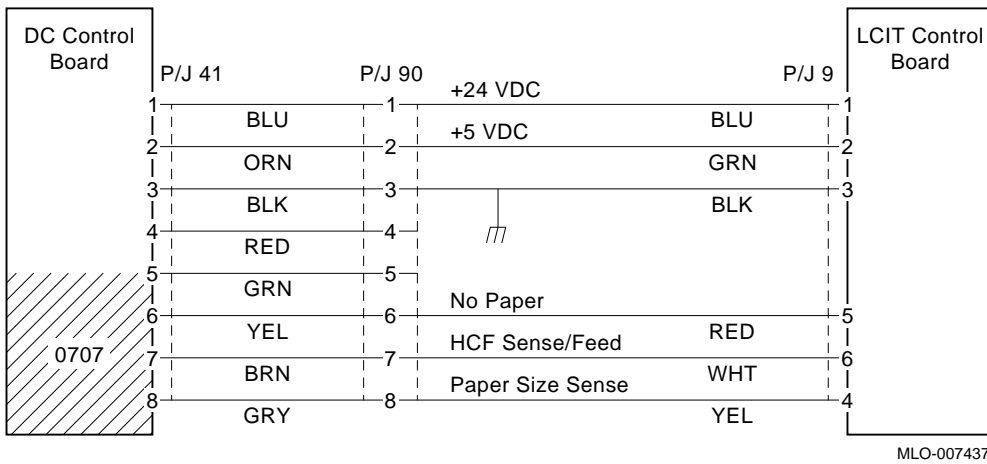

3. Swap the LCIT control board.
4. Swap the DC control board.

## 5.17 0901–0904 CARTRIDGE A

**Description:** Cartridge A refers to the print drum cartridge. One of the following codes is displayed when the print drum malfunctions. The xerographic print drum is replaced by the customer every 20,000 pages. The print drum is also referred to as cartridge A. An electronic memory is molded into the print drum cartridge. The DC control board periodically writes and reads the print drum memory. The memory device is part of the print drum and should not be disassembled in the field.

- 0191 This code is displayed after approximately 15,000 pages have been printed. The intent is to advise the customer to order a fresh print drum.
- 0902 This code is displayed after approximately 20,000 pages have been printed. Printing is disabled until a fresh compatible print drum is installed.
- 0903 This code indicated that an incompatible print drum is installed. Install the correct type drum.
- 0904 This code along is displayed if no print drum is installed.

## 5.17 0901–0904 CARTRIDGE A

**Troubleshooting:** Test the print drum by entering one of the following 1701 special function codes, as shown in Table 3–1. When the code is entered, the DC control board will read the memory and display the data or display the Fail message.

- 0282.03 Print drum memory ID
- 0282.06 Print drum memory Status
- 0900 Number of pages remaining on the print drum

If the print drum memory read fails, perform the following steps:

1. Remove the print drum and inspect the condition of the four contacts on the top of the print drum and the spring-metal contacts on the erase board. Wipe any dirt from the contacts with a soft rag. If you see any damage, pitting, or contamination replace the FRU.
2. Inspect the connection of the 6-pin plug P/J80 that connects the wire harness to the erase board.
3. Inspect the connection of the 20-pin plug P/J36 that connects to the DC control board.
4. Swap the following components:
  - a. Print drum cartridge A
  - b. DC control board
  - c. Erase board

## 5.18 0911–0914 CARTRIDGE C

**Description:** Cartridge C refers to the developer cartridge. One of the following codes is displayed when the developer cartridge malfunctions. The developer cartridge is replaced by the customer after 50,000 pages. Like the toner and print drum cartridges, the developer cartridge has an electronics memory device that the DC control board reads whenever the top cover interlock is opened and closed.

- |      |   |
|------|---|
| 0911 | This code is displayed after approximately 47,000 pages have been printed with the installed developer cartridge. The message advises the customer to purchase a fresh developer cartridge. |
| 0912 | This code is displayed when 50,000 pages have been printed and the developer cartridge must be replaced. The printer is disabled until a new cartridge is installed.                        |

## 5.18 0911–0914 CARTRIDGE C

0913 This code is displayed if a incompatible developer cartridge is installed.

0914 This code is displayed if no developer cartridge is installed.

**Troubleshooting:** Test the developer memory by entering one of the following 1701 special function codes, as shown in Table 3–1. When the code is entered, the DC control board will read the memory and display the data or display the Fail message.

- 0282.04 Developer memory identification
- 0282.07 Developer memory status
- 0901 Number of pages remaining on the developer cartridge

If the developer memory test fails, perform the following steps:

1. Remove the developer cartridge and inspect the condition of the spring contacts that connect the developer to the interconnect board. Wipe any dirt from the contacts with a soft rag. If you see any damage, pitting, or contamination, replace that FRU.
2. Inspect the connection of the 10-pin plug P/J34 that connects to the DC control board.
3. Swap the following components:
  - a. Developer cartridge C
  - b. DC control board
  - c. Developer interconnect board

## 5.19 0921–0924 CARTRIDGE B

**Description:** Cartridge B refers to the toner cartridge. One of the following codes is displayed when the toner cartridge malfunctions. Like the print drum and developer cartridges, the toner cartridge has an electronic memory device that the DC control board reads whenever the top cover interlock is opened or closed.

0921 This code is displayed when the toner is approximately 97% consumed. Toner usage is calculated by page count and typical toner coverage per page. The message advises the customer to order fresh toner.

0922 This code is displayed when approximately 750 pages have been printed after the 0921 message. When this message appears, the toner cartridge must be replaced.

0923 This message is displayed when an incompatible toner cartridge is installed.

0924 This message appears when there is no toner cartridge installed.

**Troubleshooting:** Test the toner memory by entering one of the following 1701 special function codes, as shown in Table 3–1. When the code is entered, the DC control board will read the memory or display the Fail message.

- 0282.05 Toner memory identification
- 0282.08 Toner memory status
- 0902 Number of pages remaining on the toner cartridge

If the toner memory test fails, perform the following steps:

1. Remove the developer cartridge and inspect the condition of the spring contacts that connect the developer to the interconnect board. Wipe any dirt from the contacts with a soft rag. If you see any damage, pitting, or contamination, replace that FRU.
2. Remove the toner cartridge and inspect the condition of the four contacts that connect to the toner memory.
3. Inspect the connection of the 10-pin plug P/J34 that connects to the DC control board.
4. Swap the following components:
  - a. Toner cartridge B
  - b. Developer cartridge C
  - c. DC control board
  - d. Developer interconnect board

## 5.20 1001–1005 CALL SERVICE

### 5.20 1001–1005 CALL SERVICE

**Description:** One of the following messages is displayed when a fault occurs in the fusing circuits that is shown in Figure 5–15. To clear the display, you must turn the power off, then on.

- 1001 Fuser warm-up is too slow.
- 1002 Fuser thermistor circuit is open.
- 1003 Fuser is too hot.
- 1004 Fuser is always on.

**Figure 5–15 Fuser Circuit and Connectors**

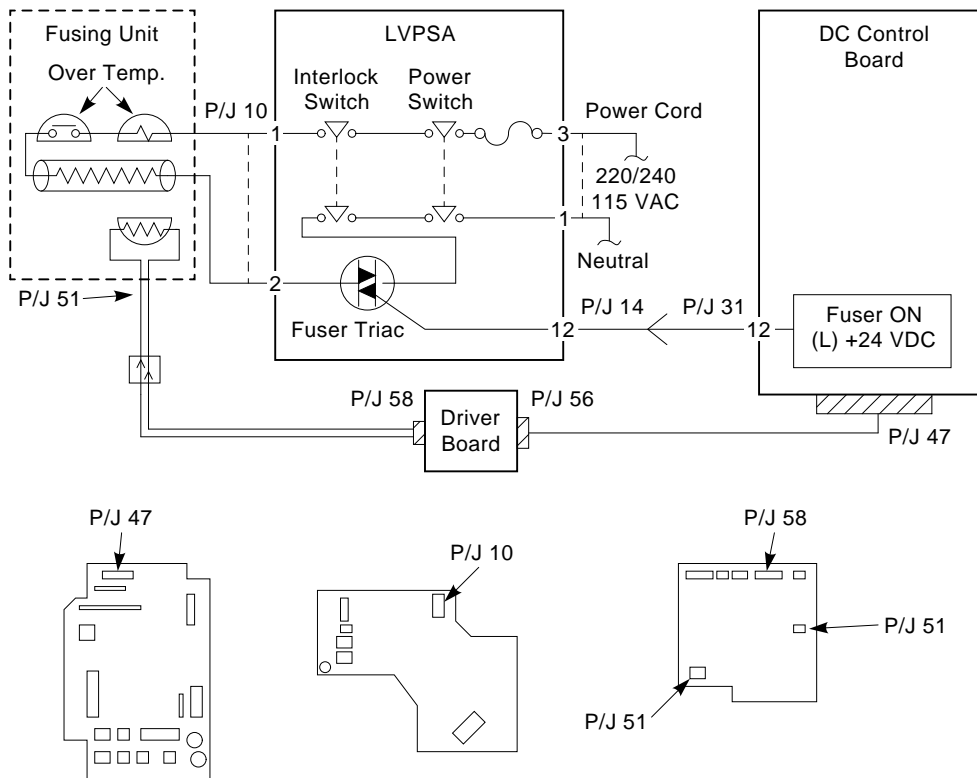

MLO-006648

**Troubleshooting:** If one of the above error codes is displayed, perform the following steps, to fix the problem:

## 5.20 1001–1005 CALL SERVICE

**Warning:** *Turn off the ac power before performing the next step.*

1. Refer to Figure 5–15, while you inspect the following:
  - 2-pin plug that connects to P10 of the LVPSA
  - 2-pin plug that connects the thermistor to the wire harness at the front of the printer.
  - P56 that connects the wire harness to the driver board
  - P/J47 that connects the wire harness to the DC control board
  - 14-pin cable that connects P/J31 of the DC control board to P/J14 of the LVPSA.
2. Swap the following FRUs:
  - Fuser unit
  - DC control board
  - LVPSA

## 5.21 1111 EMPTY THE OUTPUT TRAY

### 5.21 1111 EMPTY THE OUTPUT TRAY

**Description:** This error code is displayed when tray full sensor detects a full output tray.

**Troubleshooting:** To test the tray full sensor, enter the 1701 test code 0814, as shown in Section 3.1.3. When you lift the wire sensor linkage, the control panel should light and beep. Perform the following procedure:

1. Inspect the two clips that hold the sensor linkage to the frame of the exit assembly. Make sure the linkage is properly attached and when raised, actuates the tray full sensor. Figure 5–16 shows the clips and linkage.
2. If the sensor test fails, inspect the following:
  - 2-pin plug that connects to P/J50 of the driver board
  - P/J56 that connects the wire harness to the driver board
  - P/J47 that connects the wire harness to the DC control board
3. Swap the following:
  - Tray full sensor
  - DC control board
  - Driver board

## 5.21 1111 EMPTY THE OUTPUT TRAY

Figure 5-16 Tray Full Sensor Linkage

MLO-006691, Space=18,

## 5.22 1120 NO OFFSET

### 5.22 1120 NO OFFSET

**Description:** When this error code is displayed, the DC control board fails to detect the home position of the offset motor. Figure 5–17 shows the wiring diagram. The offset home position sensor switch is closed by a cam on the offset arm. The offset motor is in the home position when the exit rollers are toward the front of the printer.

**Troubleshooting:** Test the operation of the offset sensor by entering the 1701 test code 0815, as shown in Section 3.1.3. The control panel lights and beeps when you move the offset arm to its home position. The test fails if the sensor is intermittent, never comes on, or is always on. Perform the following steps:

1. Inspect the following:
  - 4-pin plug that connects to P/J55 on the driver board
  - P/J56 that connects the wire harness to the driver board
  - P/J47 that connects the wire harness to the DC control board
2. Swap the following:
  - DC control board
  - Driver board
  - Offset motor assembly

Figure 5-17 Offset Motor

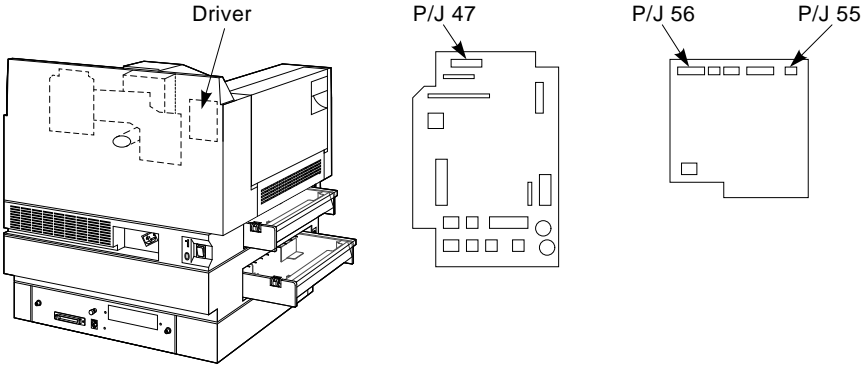
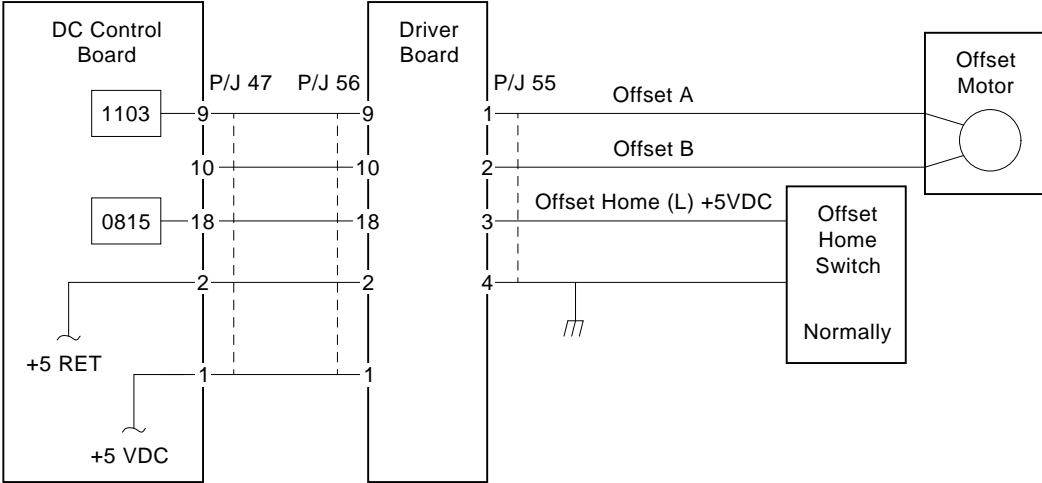

MLO-006650

## 5.23 1400–1407 COMM ERROR PRESS Defaults

### 5.23 1400–1407 COMM ERROR PRESS Defaults

**Description:** These error codes are displayed when an error occurred due to a communication problem with the video control board, the host system, or the data communication equipment (DCE) that connects the printer to the host system. Press  to continue.

**Troubleshooting:** It might be necessary to have the system manager available to assist you in troubleshooting this error message. Print several copies of the a test pattern before you perform the following steps:

1. Print a copy of the configuration sheet, as shown in Section 2.6.1.
2. Verify that the values of the communication parameters of the attached host system and printer are the same.
3. Inspect or swap the cable that connects the printer to the host system or DCE.
4. Swap the video control board.

### 5.24 1500 REPLACE CARTRIDGE 1/2

**Description:** This error code is displayed when a malfunction occurs in an installed font cartridge. Press  to continue.

**Troubleshooting:** To test the font cartridge, print a status sheet, as shown in Section 2.6.2. If the cartridge works, a listing of fonts will be printed. Perform the following steps:

1. Make sure the font cartridge can be fully installed in the slot.
2. Remove and inspect the font cartridge. Replace the cartridge if you see any damage or bent pins.
3. If the cartridge fails when installed in the opposite slot, inform the customer that the cartridge is bad.
4. If the cartridge works when installed in the opposite slot, swap the video control board.

## 5.25 1502–1503 REPLACE MEMORY BD\_1/2/3/4/5

**Description:** Press \* to continue. One of the following error codes and messages are displayed when an error is detected in an optional memory board. The memory and coprocessor boards are referred to as standard inline modules (SIMs).

Table 5–2 lists the error message and Figure 5–18 shows the location of the socket on the video control board.

**Table 5–2 Memory SIM and Socket Allocation**

	1502–1503 Display	Socket Number
❶	REPLACE MEM BD 1	J15
❷	REPLACE MEM BD 2	J14
❸	REPLACE MEM BD 3	J13
❹	REPLACE MEM BD 4	J12
❺	REPLACE MEM BD 5	J11

**Figure 5–18 1502–1503 Errors (Memory SIMs)**

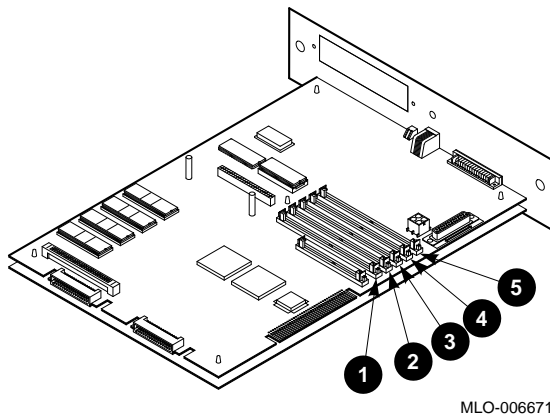

**Troubleshooting:** The displayed message identifies the failing SIM. Perform the following steps:

1. Inspect the installation of the SIM. If any pins are bent, damaged, misseated, or not mounted correctly, replace that FRU.

## 5.25 1502–1503 REPLACE MEMORY BD\_1/2/3/4/5

2. Reseat the SIM.
3. Swap the SIM.
4. Swap the video control board.

## 5.26 1508 BAD COPROCESSOR

**Description:** This error code is displayed when a fault is detected in the optional coprocessor.

**Troubleshooting:** ❶ on Figure 5–19 shows the location of the coprocessor connector P/J10 on the video control board. Perform the following steps to fix the fault:

1. Inspect the installation of the coprocessor board in P/J10 on the video control board.
2. Remove, replace, and reseat the coprocessor board.
3. Swap the coprocessor board.
4. Swap the video control board.

Figure 5–19 1508–1521 Errors

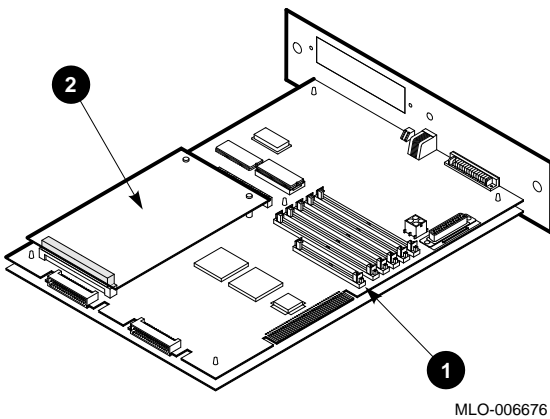

## 5.27 1509 REPLACE NVM

**Description:** This error code is displayed when an error is detected in the nonvolatile random access memory (NVRAM) that is installed in socket U38 of the video control board.

**Troubleshooting:** If the problem is intermittent, the IC might be loose or partially installed. Perform the following steps:

1. Reseat the NVRAM in socket U38.
2. Replace the video control board.

## 5.28 1520 CALL SERVICE

**Description:** This error code is displayed when an error is detected in the application specific integrated circuit on the video control board.

**Troubleshooting:** Replace the video control board.

## 5.29 1521–1523 REPLACE/ADD PDL BD/MEMORY

**Description:** This error code is displayed when an error is detected in the PDL option SIM that is installed in the socket U16 on the video control board, as shown in  Figure 5-19.

**Troubleshooting:** Use the following procedure to fix the error:

1. Remove, inspect, and reseat the PDL option board.
2. Inspect the EEPROMs that are installed in sockets U74, U81, U84, and U100 on the video control board. Make sure the integrated circuits are mounted correctly and no pins are bent.
3. Swap the PDL option board.
4. Swap the video control board.

## 5.30 1526 CALL SERVICE

**Description:** This error code is displayed when an error is detected in the communications IC on the video control board.

**Troubleshooting:** Replace the video control board.



## Paper Path Jam FIPs

As Figure 6–1 shows, this chapter includes the fault isolation procedures (FIPs) for paper path jams which are keyed to display panel error codes. Figure 6–1 shows how Chapter 6 fits into the overall troubleshooting flow. If you follow a sequence of steps to fix one problem, return to Section 4.1, Start FIP.

**Figure 6–1 Overall Troubleshooting Flow**

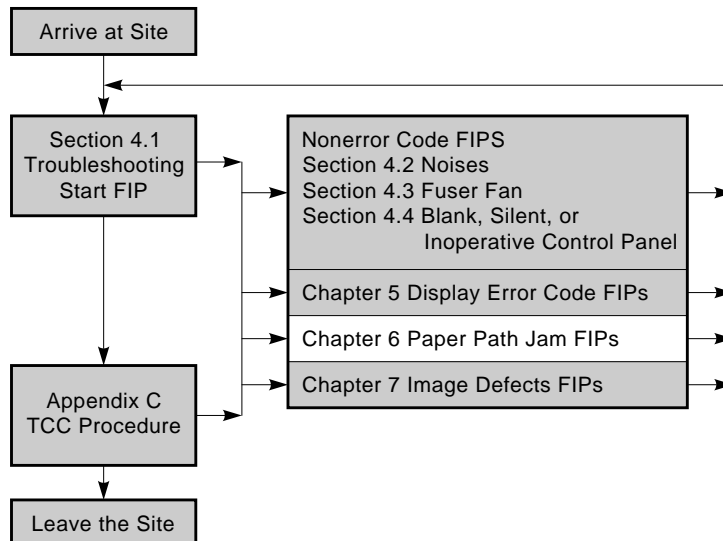

MLO-007645

## 6.1 Jams and Paper Misfeeding

### 6.1 Jams and Paper Misfeeding

When a paper path jam occurs, the CLEAR PAPER PATH message and a specific error code is displayed. Figure 6–2 uses numbered CALLOUTS to label the five paper path jam areas. Table 6–1 briefly describes each jam type error code and directs you to a specific FIP.

Figure 6–2 Paper Path Jam Areas

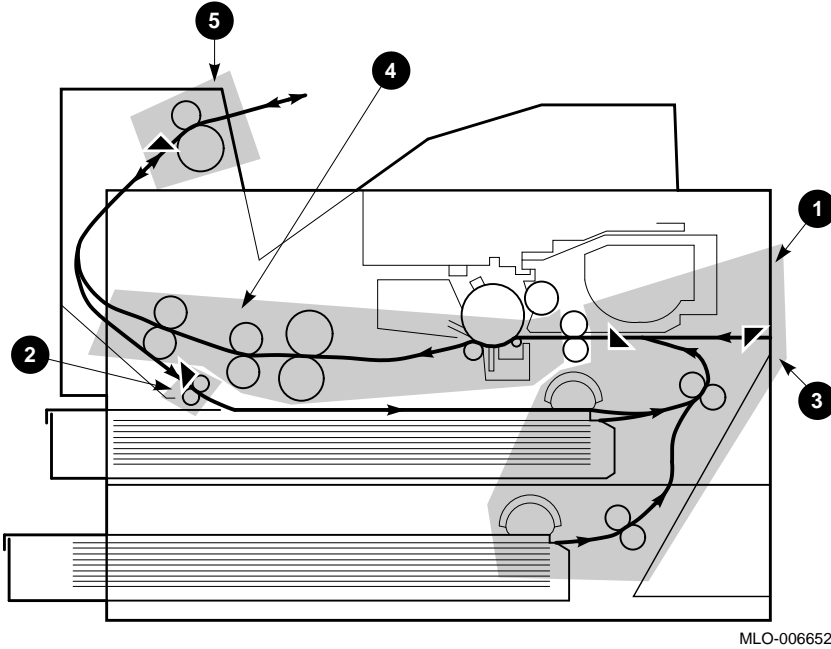

## 6.1 Jams and Paper Misfeeding

Use Table 6–1 to look up the CLEAR PAPER PATH code. The table provides a brief definition and directs you to the section for troubleshooting.

**Table 6–1 CLEAR PAPER PATH Error Code Lookup Table**

Display Code	Full Description	Brief Definition <sup>1</sup>
① 0820 0821 0822 0823 0824	Section 6.2	Paper stalled under registration or failure to feed from the following input: —Bypass preregistration jam —Upper preregistration jam —Lower preregistration jam —LCIT preregistration jam —Duplex refeed preregistration jam
② 0826	Section 6.3	Duplex refeed leading edge jam
0827	Section 6.4	Duplex refeed trailing edge jam
③ 0830 0831 0832 0833 0834	Section 6.5	Shingle type jam in the following areas: — Bypass or manual feeding — Upper cassette feed failure — Lower cassette feeding — LCIT feeding — Duplex refeed feeding
④ 1020 1021 1022 1023 1024	Section 6.6	Fuser or gate exit sensor jam feeding from the following inputs: — Bypass entrance — Upper cassette — Lower cassette — LCIT — Duplex refeed
⑤ 1025	Section 6.7	Exit leading edge jam
1026	Section 6.8	Exit trailing edge jam

<sup>1</sup>Printing stops until operator attends to the problem. To clear this error, a door or sensor needs to actuate.

## 6.2 0820–0824 CLEAR PAPER PATH

### 6.2 0820–0824 CLEAR PAPER PATH

**Description:** The error codes 0820 through 0824 indicate a feed failure or preregistration jam. The error codes occur after the leading edge fails to actuate the registration sensor in time. The cause of the error can be the registration transport, the specific feed source, or any of the electronic or mechanical support devices.

The following table and Figure 6–3 identify and locate the paper path components that cause 0820 through 0824 error codes:

- ❶ Registration sensor and the paper path guides of the registration transport. These components and the upper turn rollers are common to all the feed sources.
- ❷ Bypass sensor and LCIT feed source
- ❸ Upper cassette, upper feed roller, and upper turn rollers
- ❹ Lower cassette, lower feed roller, and lower turn rollers
- ❺ Duplex refeed paper path

Figure 6–3 Registration Jam Path

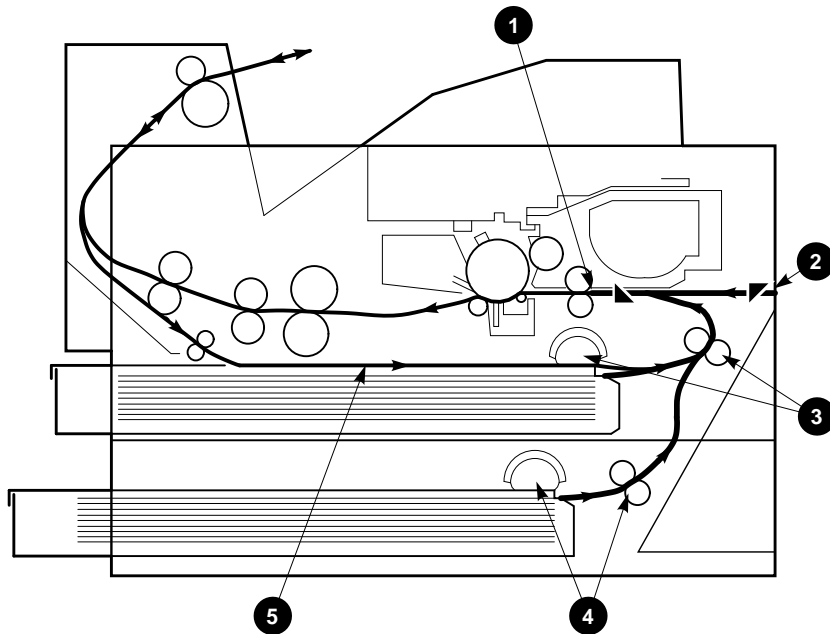

MLO-006653

**0800–0824 Troubleshooting:** First use the following steps to isolate the problem to either the registration transport or to a malfunctioning feed source. Then the FIP directs you to the appropriate 0800–0824 FIP. Section 6.2.1 presents tests and a wiring diagram for the registration transport, which you can use to isolate a malfunction beyond the FRU level.

1. Make sure the cassettes or LCIT is properly loaded with the correct size and type of paper.
2. Test and repair the paper path by first feeding sheets from the upper cassette, then feeding from the lower cassette. When you are certain that the cassettes function correctly, feed from the LCIT.
3. Perform the steps below if either of the following symptoms occur, if not, go to step 4:
  - If 0821 appears intermittently, at powerup, or if no paper is found in the paper path.

## 6.2 0820–0824 CLEAR PAPER PATH

- If the sheet jams in the area of the registration sensor or upper turn roller after successfully feeding from a cassette, LCIT, or bypass slot.
  - a. Inspect the upper turn pinch roller which is on the feed door. Make sure the roller turns freely and the pressure springs and door are installed properly.
  - b. Inspect the gears that drive the upper turn rollers. Look for missing teeth or gear damage and listen for thumps or grinding noises during printing.
  - c. Inspect the 6-pin connector, which is located next to the registration clutch, and plugs into P/J38 on the back of the DC control board. The registration and upper turn roller clutches and the registration sensor connect through this plug.
  - d. Swap the registration transport.
  - e. Swap the DC control board.
- 4. Turn to one of the following FIPs if the sheet never reaches the upper turn roller or never leaves the selected feed source:
  - Section 6.2.2, 0820 Paper Under the BYPASS Sensor
  - Section 6.2.3, 0821 Upper Cassette Feed Failure
  - Section 6.2.4, 0822 Lower Cassette Feed Failure
  - Section 6.2.5, 0823 LCIT Feed Failure
  - Section 6.2.6, 0824 Duplex Refeed Failure

### 6.2.1 Registration Transport Diagram and Tests

The following tests and wiring diagram can be used to troubleshoot the registration sensor and clutch beyond the FRU level:

- Enter 1701 test code 0810. The SENSING prompt should appear. When you manually actuate the registration sensor, the control panel lights up and beeps. Figure 6–4 shows the components of the registration sensor circuit.
- When you enter the 1701 test code 0851, the upper turn roller clutch will energize for 10 seconds. Test the clutch by manually rotating the upper turn roller. It must turn freely when the clutch is deactivated and lock up when the clutch is energized.

## 6.2 0820–0824 CLEAR PAPER PATH

- Enter 1701 test code 0400.01 to run the drive gears. Look for jerky motion caused by missing teeth or gear damage and listen for thumps or grinding noises.

**Figure 6–4 Registration Sensor and Upper Turn Clutch**

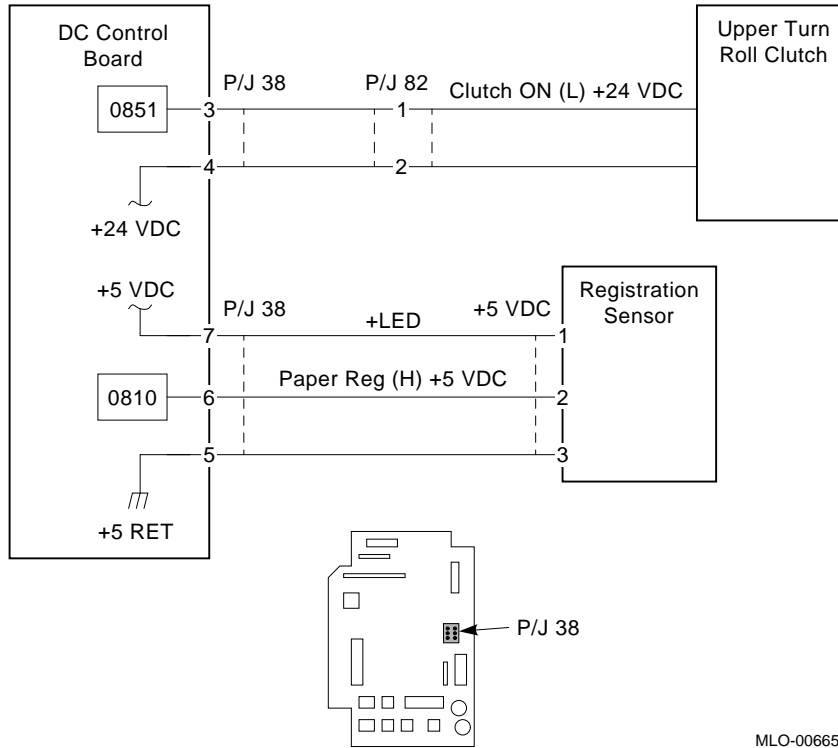

## 6.2 0820–0824 CLEAR PAPER PATH

### 6.2.2 0820 Paper Under the BYPASS Sensor

**Note:** *Before performing the following FIP steps, make sure you have completed all the steps in Section 6.2 at the beginning of this procedure.*

**Description:** This code is displayed when paper is stalled under the bypass sensor. This occurs when feeding from the LCIT or other optional equipment.

**Troubleshooting:**) Test the bypass sensor by entering the 1701 Test codes 0710. Figure 6–5 shows the wiring diagram. Perform the following steps to fix a problem.

1. Inspect the following for misconnection or mechanical damage:
  - 3-pin, P/J71 plug connecting to P/J71 on the developer interconnect board
  - 10-pin jack that connects to P/J34 on the DC control board. (Pin three of P/J34 goes high when the sensor is actuated.)
  - Bypass feed sensor linkage
  - Bypass feed sensor mounting
2. Swap the following components:
  - Bypass sensor
  - Developer interconnect board
  - DC control board

Figure 6–5 Bypass Sensor Diagram

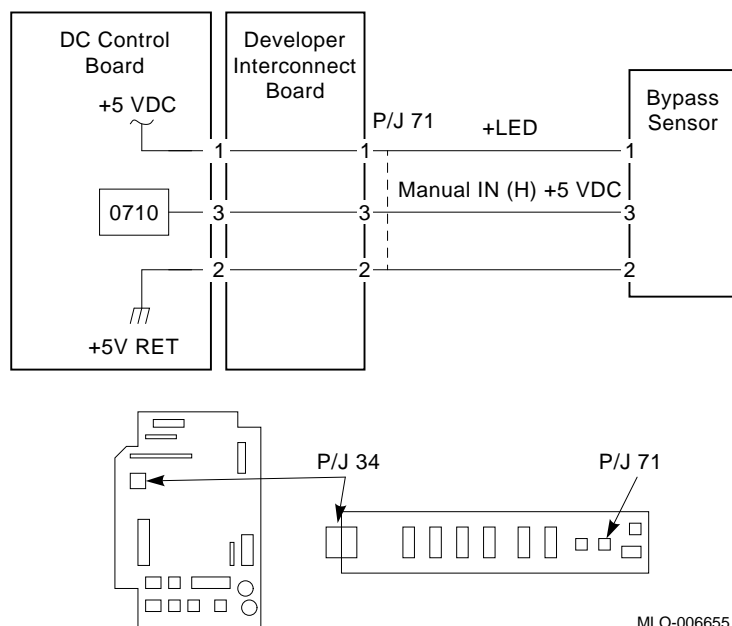

### 6.2.3 0821 Upper Cassette Feed Failure

**Note:** Before performing the following FIP steps, make sure you have completed all the steps in Section 6.2 at the beginning of this procedure.

**Description:** The following events cause this message to appear:

- Stalled paper holding down the registration sensor or a bad sensor.  
If this error is constantly displayed or appears intermittently, at powerup or without feeding, go to Section 6.2
- The result of a misfeed from the upper cassette. The sheet never reached the registration sensor in time. The error occurs after a feed attempt.

**Troubleshooting:** If the paper never leaves the upper cassette or fails to reach the upper turn rollers, do the following:

1. Make sure the cassette is properly loaded with the correct size and type of paper.
2. Swap the upper cassette.
3. Look for paper path obstructions in the registration transport assembly and the feed door.

## 6.2 0820–0824 CLEAR PAPER PATH

4. Test the upper feed solenoid by entering the 1701 Test code 0801. When entered, the solenoid energizes 5 times. You can hear it click and see it operate. If the solenoid fails to operate or operates sluggishly, do the following:
  - Inspect the 2-pin connector that plugs the upper feed solenoid into P/J39 on the lower part of the DC control board. (See Figure 6–6.)
  - Swap DC control board.
  - Swap upper solenoid.
5. Inspect the upper feed roller drive gears for any damage or missing teeth.
6. Clean the paper feed rollers, as shown in Section 10.5.
7. Swap the upper feed roller/clutch.

**Figure 6–6 Upper Feed Solenoid Diagram**

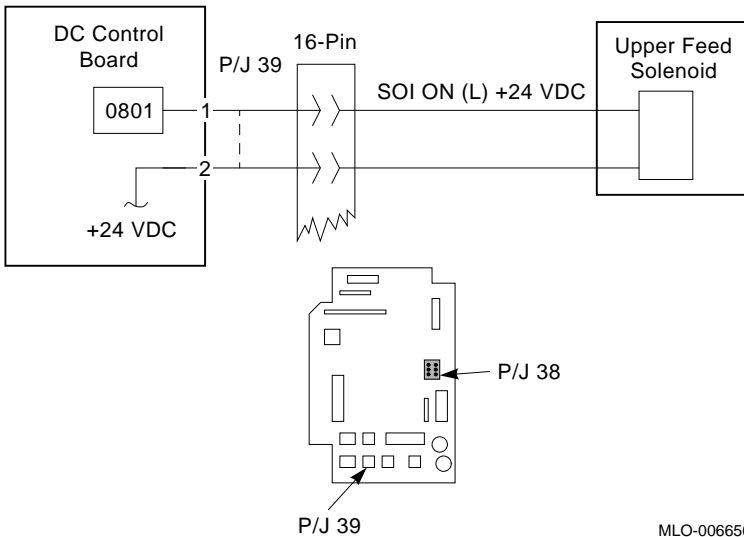

MLO-006656

### 6.2.4 0822 Lower Cassette Feed Failure

**Note:** Before performing the following FIP steps, make sure you have completed all the steps in Section 6.2 at the beginning of this procedure.

**Description:** This message is displayed when a misfeed occurs when feeding from the lower cassette. The sheet never reached the registration sensor in time. The error occurs after a feed attempt.

## 6.2 0820–0824 CLEAR PAPER PATH

**Troubleshooting:** If the paper never leaves the lower cassette or fails to reach the upper turn rollers, do the following:

1. Make sure the cassette is properly loaded with the correct size and type paper.
2. Swap the lower cassette.
3. Look for paper path obstructions in the registration transport assembly and the feed door.
4. If the paper feeds but stops halfway up the paper path, the spacer ❶ (see Figure 6–7) might be missing from underneath the lower feed solenoid. The spacer was added to early printers to correct a slight timing problem. On later models the height of the plastic boss ❷ that the solenoid mounts on was altered to eliminate the spacer.

**Figure 6–7 Lower Feed Solenoid Spacer**

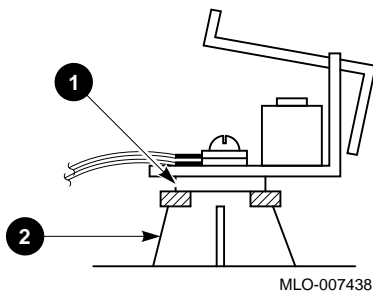

5. Test the lower feed solenoid by entering the 1701 Test code 0802. When entered the solenoid energizes 5 times. You can hear it click and see it operate. If the solenoid fails to operate or operates sluggishly, do the following:
  - Inspect the 2-pin connector that plugs the lower feed solenoid into P/J40 on the lower part of the DC control board. (See Figure 6–8.)
  - Swap the DC control board.
  - Swap the lower feed solenoid.

## 6.2 0820–0824 CLEAR PAPER PATH

Figure 6–8 Lower Feed Solenoid and Turn Clutch

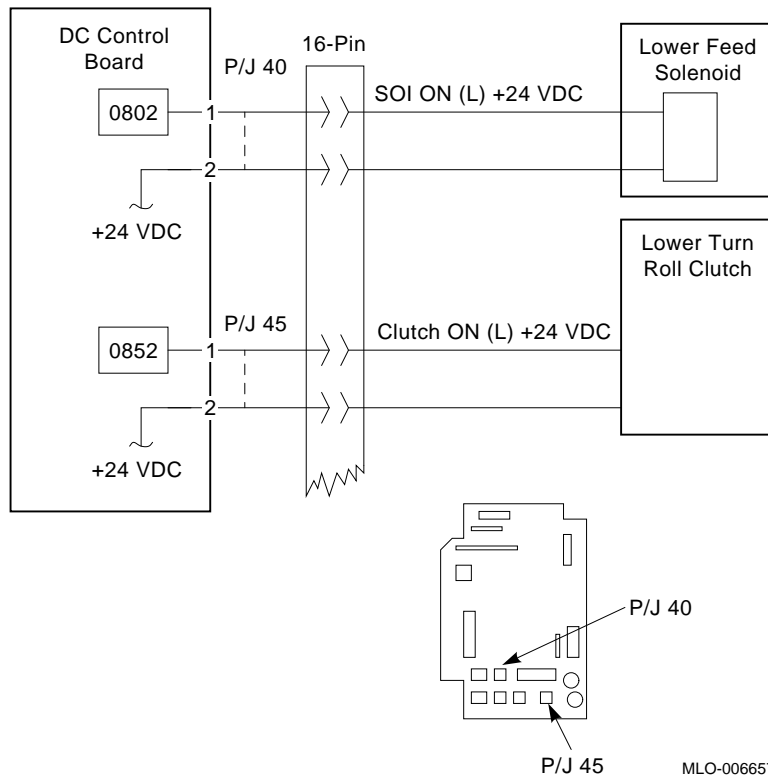

6. Enter 0852 to energize the lower turn roller clutch for 10 seconds. Test the clutch by manually rotating the lower turn roller. It must turn freely when the clutch is deactivated and lock up when the clutch is energized. If the test fails, swap the lower turn drive roller and clutch.
7. Inspect the lower feed roller drive gears for any damage or missing teeth.
8. Clean the paper feed rollers, as shown in Section 10.5.
9. Swap the lower feed roller/clutch.

### 6.2.5 0823 LCIT Feed Failure

**Note:** *Before performing the following FIP steps, make sure you have completed all the steps in Section 6.2 at the beginning of this procedure.*

**Description:** The sheet failed to reach the registration sensor when feeding from the large capacity input tray (LCIT). This error can be caused by an obstructed paper path, bad registration sensor, or several LCIT malfunctions.

**Troubleshooting:** Before performing the following procedure, select a cassette and feed test prints from it. Fix any problems that occur. This will verify that the registration sensor is working correctly.

1. Make sure the LCIT is plugged into the printer and the lead-in cable is in good condition.
2. Run the elevator up and down to check the operation of the LCIT. If this test fails, go to Chapter 11 to diagnose the LCIT.
3. Remove, inspect, and fan the paper in the LCIT. Look for damage, sticking, or wrinkling and curling.
4. Ensure that both feed roller springs are properly attached to the frame in the second hole from the top, as shown in Section 11.4.11.
5. Inspect the following paper path guides. Look for obstructions, improper installation, cuts, bends, adhesive contamination, and other types of damaged.
  - Bypass entrance guide that is part of the right-side cover
  - Top of the registration transport
  - Bottom of the developer cartridge
  - Top cover of the LCIT. Make sure all the screws are installed.
  - LCIT mounting bracket and alignment pins
  - LCIT paper snubbers
6. Make sure both of the directional LCIT paper feed rollers are correctly installed on the shaft, as shown in Section 11.4.11. If the paper feed roller is installed backwards, the shaft will not turn it.

## 6.2 0820–0824 CLEAR PAPER PATH

7. Inspect all the connectors and associated wires shown in Figure 6–9. Make sure none are plugged in backwards and that they are in good condition:
8. Swap the following:
  - LCIT control board
  - Paper feed motor
  - DC control board

**Figure 6–9 LCIT Paper Feed Connectors**

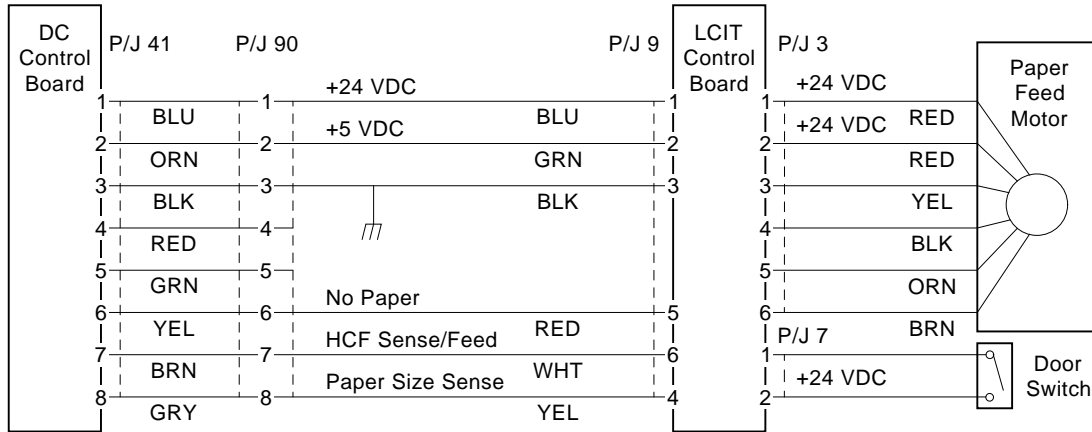

MLO-007439

### 6.2.6 0824 Duplex Refeed Failure

**Note:** *Before performing the following FIP steps, make sure you have completed all the steps in Section 6.2 at the beginning of this procedure.*

**Description:** This error code is displayed when a sheet fails to reach the registration sensor after feeding from the duplex refeed position. The duplex refeed paper path consists of the top of the upper cassette, the upper feed roller, and upper turn roller. You can assume that the refeed rollers and sensor worked all right if a 1025 error code was not displayed.

**Troubleshooting:** This error can occur if feeding shorter paper and may not occur feeding longer paper. If the upper feed roller fails to turn, the shorter sheet will stall on top of the cassette. The refeed rollers push the longer sheet into the upper turn rollers. Perform the following procedure:

1. Test the upper cassette simplex paper path and fix any problem that you find.
2. Remove the upper cassette. Inspect the clear plastic cassette top and the roof of the upper cassette slot for damage or adhesive contamination.
3. Swap the cassette.

## 6.3 0826 CLEAR PAPER PATH

### 6.3 0826 CLEAR PAPER PATH

**Description:** This error is displayed when paper is stalled underneath the refeed sensor ❶ or if the refeed sensor fails to detect the leading edge of the sheet in time. The reversing action of the exit rollers ❷ feeds the trailing edge into the refeed sensor and then into the refeed rollers ❸.

Figure 6–10 Refeed Leading Edge Jam

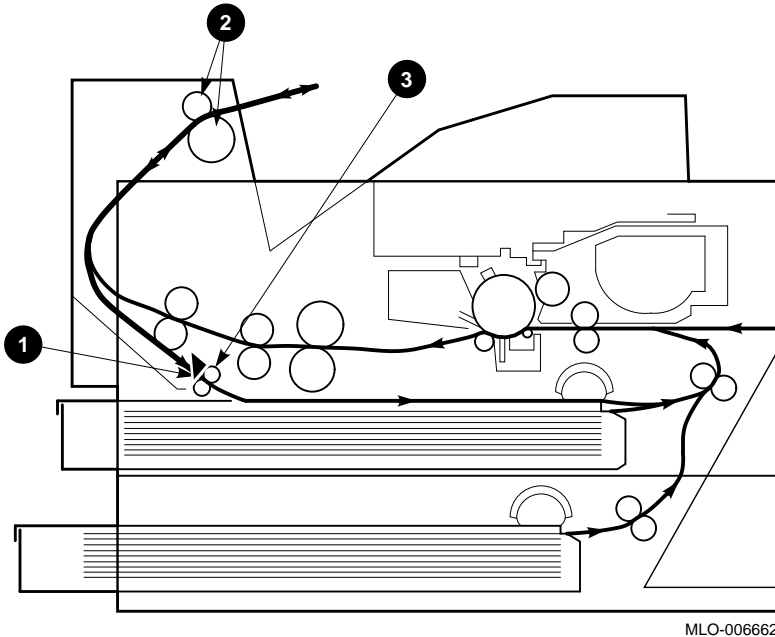

**Troubleshooting:** If the duplex refeed sheet fails to arrive underneath the feed roller, the top sheet in the upper cassette may feed in its place. Before troubleshooting this problem, test the upper cassette simplex paper path and fix any problem that you find. Figure 6–11 is a diagram of the refeed sensor and clutch.

1. Inspect the refeed paper path of the following FRUs. Look for bends caused by improper installation; sticky or binding sensor linkage; or for broken, nicked, or cut plastic.

## 6.3 0826 CLEAR PAPER PATH

2. Test the refeed sensor circuit by entering the 1701 Test code 0813. The SENSING display will appear. When you actuate the sensor, the beeper sounds and control panel lights up. Do the following if the test fails:
  - a. Inspect the 3-pin plug that connects the refeed sensor to the connector in the exit chassis.
  - b. Inspect the 20-pin plug that connects P/J56 on the driver board to P/J47 on the DC control board.
  - c. Swap the following:
    - Refeed sensor
    - Driver board
    - DC control board.
3. Test the reverse operation of the exit rollers by entering the 1701 Test code 1102. If the test fails, do the following:
  - a. Inspect the 20-pin plug that connects P/J56 on the driver board to P/J47 on the DC control board.
  - b. Inspect the 6-pin plug connecting the exit motor to P/J54 on the driver board.
  - c. Swap the following:
    - DC control board.
    - Driver board.
    - Exit motor.

## 6.3 0826 CLEAR PAPER PATH

Figure 6–11 Refeed Sensor and Clutch

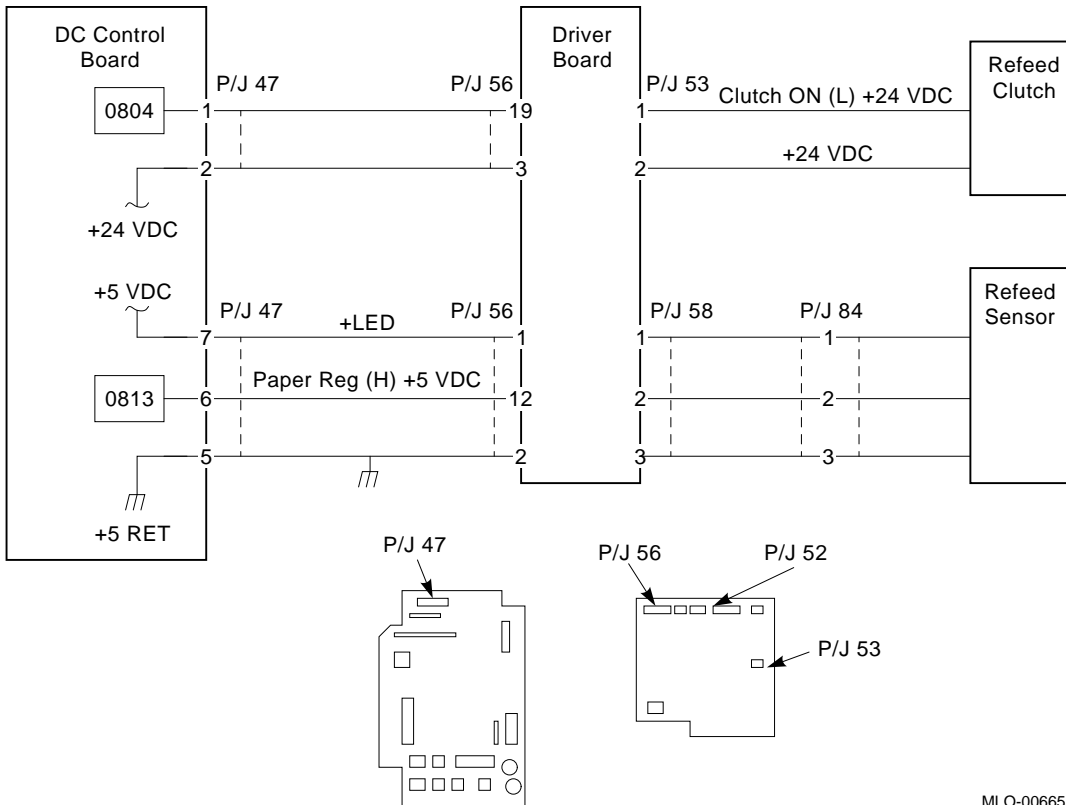

MLO-006658

## 6.4 0827 CLEAR PAPER PATH

**Description:** This error is displayed when the refeed sensor ❶ fails to detect the trailing edge in time. This error can be caused by paper path obstructions, by a malfunction of the refeed rollers, or refeed clutch.

Figure 6–12 Refeed Trailing Edge Jam

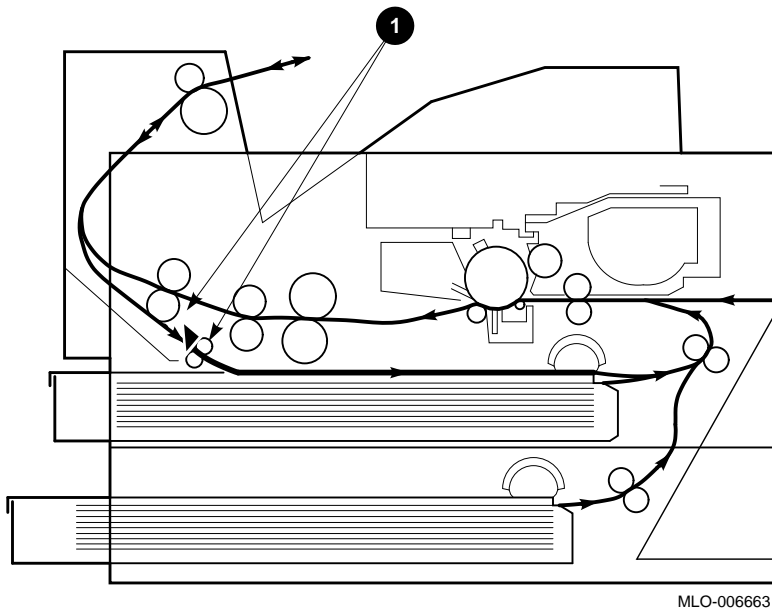

**Troubleshooting:** You may notice that the exit rollers chatter as they push the sheet through the stalled refeed rollers. Since the refeed sensor detected the leading edge of the sheet, it is probably all right. To test the refeed sensor, use the procedure supplied in Section 6.3. Perform the following procedure:

1. Remove and inspect the upper cassette for the following:
  - Is the clear plastic cassette top missing, broken, or contaminated with adhesives?
  - Are there any cuts or burs on the top of the cassette?
  - Is the roof of the upper cassette slot damaged?
2. Remove the upper cassette to access the refeed pinch roller. Use your fingers to test the pinch roller pressure. If the pinch roller pressure is uneven, inspect and fix the pinch roller springs.
3. Test the refeed roller clutch by entering the 1701 Test code 0804. The refeed roller clutch will energize for 10 seconds.

## 6.4 0827 CLEAR PAPER PATH

Test the clutch by manually rotating the refeed rollers. It must turn freely when the clutch is deactivated and lock up when the clutch is energized.

- If the clutch test fails, and the pinch roller pressure is all right, swap the following:
  - DC control board
  - Driver board
  - Refeed clutch
- If the clutch test passes, enter 0400.01 to run the refeed roller drive gears. Look for jerky motion caused by missing teeth or gear damage and listen for thumps or grinding noises. The top cover must be closed for this test to work.

## 6.5 0830–0834 CLEAR PAPER PATH

**Description:** Error codes 0830 through 0834 indicate a registration or shingle type jam. When the registration sensor fails to detect the trailing edge of the sheet, the error code for that feed source is displayed. The 830–834 errors are caused by paper path obstructions or if a feed, turn, or registration roller is damaged.

Do not confuse the trailing edge error codes with the leading edge error codes (0820 through 0824). No feed failure is implied. The following table and Figure 6–13 identify and locate the paper path components that cause 0830 through 0834 error codes.

- ❶ Registration sensor and rollers
- ❷ Manual, bypass, or LCIT feed path
- ❸ Upper cassette and upper turn rollers feed path
- ❹ Lower cassette and lower feed rollers feed path
- ❺ Duplex refeed feed path

Figure 6–13 Registration or Shingle Jams

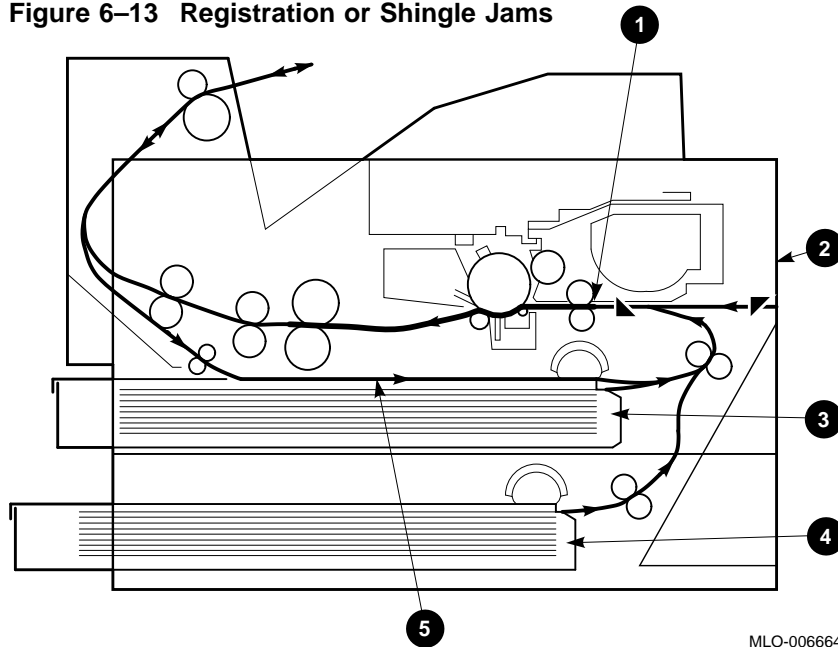

MLO-006664

**Troubleshooting:** First use the following steps to isolate the problem to either the registration transport or to a malfunctioning feed source. Then, the FIP directs you to the appropriate 0830–0834 FIP. Section 6.5.1 presents tests and wiring diagram for the registration clutch and sensor, which you can use to isolate a malfunction beyond the FRU level.

1. Make sure the correct size and type of paper is being used.
2. Test and repair the paper path by first feeding sheets from the upper cassette, then feeding from the lower cassette. When you are certain that the cassettes function correctly, feed from the LCIT.
3. Perform the following steps only if jamming occurs when feeding from all feed sources:
  - Inspect the paper path guides of the registration transport and feed door for damage that would drag on the sheet.
  - Replace the registration transport assembly if the surface of the registration and upper turn rollers are dirty, glazed, or oily.
  - Inspect the upper and lower turn pinch rollers, that are on the feed door. Make sure the rollers turn freely and the pressure springs and door are installed properly.

## 6.5 0830–0834 CLEAR PAPER PATH

- Swap the developer unit.
  - Swap the registration transport.
  - Swap the DC control board.
4. If the error occurs only when feeding from one input source, turn to one of the following procedures:
- Section 6.5.2, 0830 Manual Feeding
  - Section 6.5.3, 0831 Upper Cassette
  - Section 6.5.4, 0832 Lower Cassette
  - Section 6.5.5, 0833 LCIT Feeding
  - Section 6.5.6, 0834 Duplex Refeed

### 6.5.1 Tests and Wiring Diagram

The following tests and the Figure 6–14 wiring diagram can be used to troubleshoot to components beyond the FRU level:

- Enter 0400.01 to run the drive gears. Look for jerky motion caused by missing teeth or gear damage and listen for thumps or grinding noises.
- Enter 0810 and manually actuate the registration sensor. If the test fails, swap the registration sensor and DC control board.
- Test the upper turn and registration roller clutches for slippage. Test the clutch by manually rotating the roller. The roller must turn freely when the clutch is deactivated and must lock up when the clutch is energized.
  - Enter 0851 for the upper turn roller clutch (shown in Figure 6–4).
  - Enter 0805 for the registration roller clutch.

## 6.5 0830–0834 CLEAR PAPER PATH

Figure 6–14 Registration Sensor and Clutch

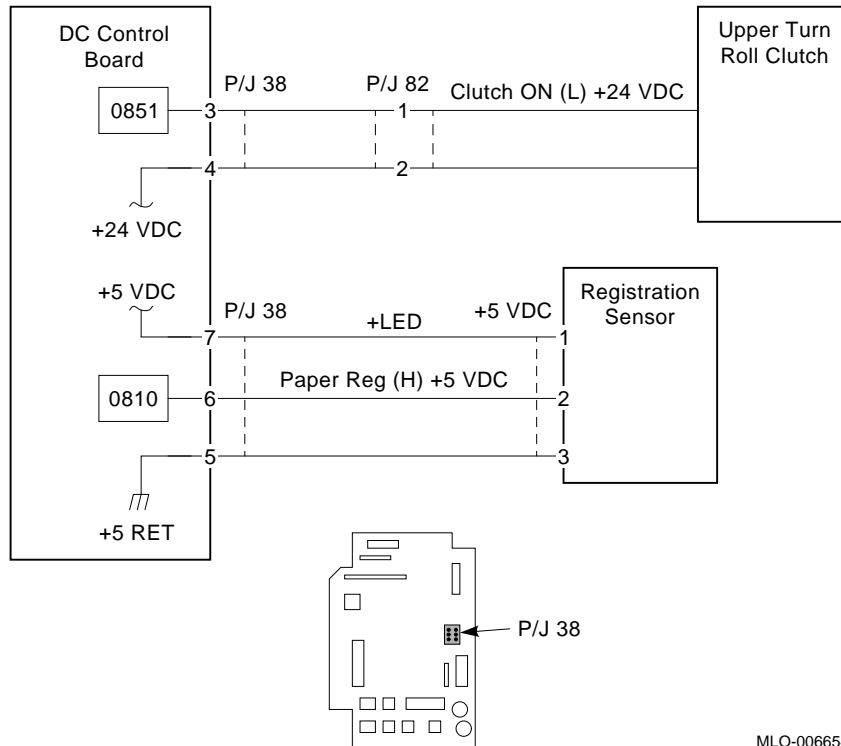

MLO-006654

## 6.5 0830–0834 CLEAR PAPER PATH

### 6.5.2 0830 Manual Feeding

**Description:** This error code is displayed when the registration sensor fails to detect the trailing edge or the sheet that is manually fed from the bypass slot.

**Troubleshooting:** Before you perform this procedure turn to Section 6.5.

1. Check for the following operator problems:
  - Inserts the sheet too late.
  - Fails to fully insert the sheet. The registration rollers fail to grab the leading edge.
  - Operator is inserting the wrong size paper.
2. Inspect the manual feed section of the registration transport for damage that would drag on the sheet and also inspect the surface of the registration rollers for dirt, glazing, or oil contamination.
3. Examine the mounting of the right side cover.
4. Swap the following:
  - Registration transport
  - Development unit

### 6.5.3 0831 Upper Cassette

**Description:** This error message is displayed when the registration sensor fails to detect the trailing edge of a sheet that is fed from the upper cassette.

**Troubleshooting:** Before you perform this procedure, turn to Section 6.5.

1. Make sure the cassette is loaded with the correct size paper.
2. Make sure the cassette is not overloaded.
3. Remove and fan the paper in the cassette.
4. Enter the 1701 Test code 0711 to read the cassette magnets. See Table 6–2 and Figure 6–15.

**Table 6–2 Cassette Size-sensing**

Cassette Paper Size	Size-sensing Magnets		
	S1	S2	S3
Cassette not installed	0	0	0
A4	0	1	0
A5	1	1	0
8.5 in. x 14 in.	0	1	1
8.5 in. x 11 in.	1	1	1

**Figure 6–15 Cassette Magnets**

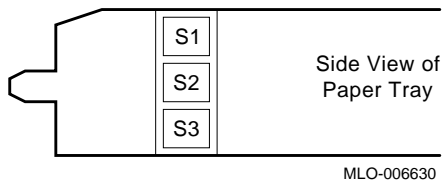

5. Swap the upper cassette.
6. Test the upper feed solenoid by entering the 1701 test code 0801. When entered, the solenoid energizes 5 times. You can hear it click and see it operate. If the solenoid fails to operate or operates sluggishly, replace it.
7. Swap the DC control board.
8. Inspect the upper feed roller drive gears for any damage or missing teeth.

## 6.5 0830–0834 CLEAR PAPER PATH

9. Swap the upper feed roller/clutch.

### 6.5.4 0832 Lower Cassette

**Description:** This error message is displayed when the registration sensor fails to detect the trailing edge of a sheet that is fed from the lower cassette.

**Troubleshooting:** Before you perform this procedure, turn to Section 6.5.

1. Make sure the cassette is loaded with the correct size paper.
2. Make sure the cassette is not overloaded.
3. Remove and fan the paper in the cassette.
4. Inspect the cassette size-sensing magnets.
5. Enter the 1701 Test code 0712 to read the cassette magnets. See Table 6–2.
6. Enter the 1701 test code 0852 to energize the lower turn roller clutch. Test the clutch by manually rotating the roller. It must turn freely when the clutch is deactivated and must lock up when the clutch is energized.
7. Inspect the lower turn pinch roller that is on the feed door. Make sure the roller turns freely, and the pressure springs and door are installed properly.
8. Test the lower feed solenoid by entering the 1701 test code 0802. When entered, the solenoid energizes 5 times. You can hear it click and see it operate. If the solenoid fails to operate or operates sluggishly, replace it.
9. Inspect the lower feed roller drive gears for any damage or missing teeth.
10. Swap the DC control board.
11. Swap the lower feed roller and clutch.

### 6.5.5 0833 LCIT Feeding

**Description:** This error is displayed when the registration sensor fails to detect the trailing edge of the sheet that is fed from the LCIT feeder. This can occur in multisheet or shingle type feed failures.

**Troubleshooting:** Before you perform this procedure, turn to Section 6.5.

Feed test prints from the upper and lower cassettes before performing the following procedure:

- a. Make sure the LCIT is plugged into the printer and the lead-in cable is in good condition.
- b. Run the elevator down and check the operation of the LCIT. If this test fails, go to Chapter 11 to diagnose the LCIT.

## 6.5 0830–0834 CLEAR PAPER PATH

- c. Remove, inspect, and fan the paper in the LCIT. Look for damage, sticking, wrinkling, or curling.
- d. If the last sheet multifeeds, inspect the surface of the cork pads on the front of the elevator. If the pads are glazed, greasy, or otherwise contaminated, replace the LCIT.
- e. Inspect the LCIT paper snubbers and replace the LCIT if the snubbers are bent, rusted, broken, or otherwise damaged.
- f. Swap the following:
  - LCIT control board
  - Paper feed motor
  - DC control board

### 6.5.6 0834 Duplex Refeed

**Description:** This error code is displayed when the registration sensor fails to detect the trailing edge of a sheet that is fed from the duplex refeed. The duplex refeed paper path consists of the top of the upper cassette, the upper feed, and turn rollers.

**Troubleshooting:** Before you perform this procedure turn to Section 6.5:

1. Before troubleshooting this problem, test the upper cassette simplex paper path and fix any problem that you find.
2. Remove the upper cassette and inspect it for the following damage:
  - Is the clear plastic cassette top missing, broken, or contaminated with adhesives?
  - Cuts, burs, or cracks on the cassette top?
  - Is the roof of the upper cassette slot damaged?
3. Swap the cassette.

## 6.6 1020–1024 CLEAR PAPER PATH

### 6.6 1020–1024 CLEAR PAPER PATH

**Description:** The following error codes are displayed when the gate sensor ❶ fails to detect the leading or trailing edge of a sheet. The gate sensor is part of the driver board and its linkage sits across the output of the postfuser transport ❷.

1020	Bypass entrance feeding
1021	Upper cassette feeding
1022	Lower cassette feeding
1023	LCIT feeding
1024	Duplex refeed feeding

Figure 6–16 Gate Area Jams

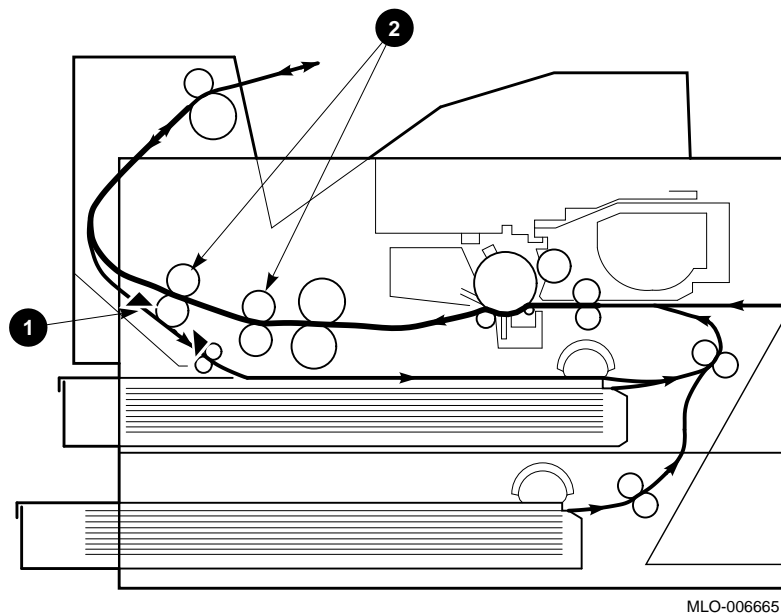

**Troubleshooting:** Use the Test Print menu (See Section 3.3 ) to feed a sheet and identify the location of the jam. If the error code is between 1020–1023, the sheet must be jammed before, in, or after the fusing rollers. Keep this jam location in mind when performing the following steps:

1. Inspect the following areas for paper path damage or obstructions:
  - Transfer/separation charger area

## 6.6 1020–1024 CLEAR PAPER PATH

- Prefuser transport and fuser entrance areas
  - Fuser exit and postfuser transport area
2. If the top half of the postfuser transport is not closed, the sheet will ride over the sensor and stall. When the exit door closes it pushes the levers that grab and lock the upper plate of the postfuser transport.
  3. If the surface of the registration roller is dirty, glazed, or oily, replace the registration transport assembly.
  4. If the surface of either exit roller is dirty, glazed, or oily, replace the roller.
  5. Inspect the registration pinch roller that is mounted on the underside of the developer unit. Make sure it turns freely and the pressure springs function.
  6. Test the gate sensor circuit by entering the 1701 test code 0811. After entering, manually actuate the gate linkage: If the sensor test fails, do the following:
    - Inspect the condition and mounting of the gate sensor linkage. (See Figure 6–17.)
    - Swap the drive board.
    - Swap the DC control board.
  7. Test the registration roller clutch by entering the 1701 test code 0805. After entering, the clutch will energize for a 10 second interval. To test the clutch for slippage, manually rotate the roller. It must turn freely when the clutch is off and must lock up when the clutch is energized.  
If the test fails, swap the registration transport assembly or DC control board. (Figure 6–4 shows the wiring diagram.)

## 6.6 1020–1024 CLEAR PAPER PATH

Figure 6–17 Gate Linkage and Sensor Circuit

MLO-006992, Space=20, Comments

(continued on next page)

Figure 6–17 (Cont.) Gate Linkage and Sensor Circuit

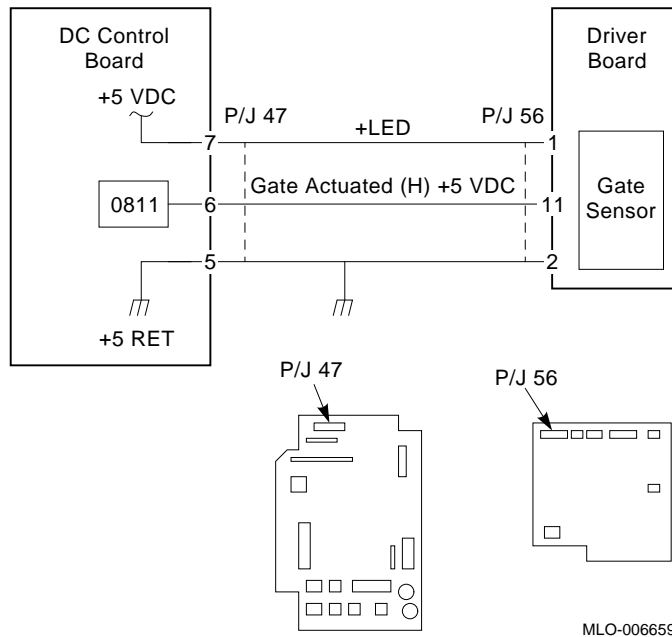

8. Test the operation of the exit roller and drive by entering the 1701 test code 1100. The rollers must run smoothly and without noise. (Figure 6–22 shows the wiring diagram.) Do the following if the test fails:
  - Inspect the 20-pin plug that connects P/J56 on the driver board to P/J47 on the DC control board.
  - Inspect the 6-pin plug connecting the exit motor to P/J54 on the driver board.
  - Swap the DC control board.
  - Swap the driver board
  - Swap the exit motor
  
9. Enter the 1701 test code 0400.01 to run the motor test. As the following rollers run, look for jerky motion caused by missing teeth or gear damage and listen for thumps or grinding noises.
  - Upper and lower registration rollers

## 6.6 1020–1024 CLEAR PAPER PATH

- Single prefuser transport roller
  - Upper and lower fuser unit rollers
  - Upper and lower postfuser rollers
10. When the top door closes, a tang on the top cover presses the lever, shown as ❶ in Figure 6–18. The lever disengages the gear that driver rollers of the fuser and postfuser transport. Inspect the operation of the lever.

**Figure 6–18 Exit Gear Lever**

MLO-006993 SPACE=18

## 6.7 1025 CLEAR PAPER PATH

**Description:** This error code is displayed when the exit sensor ❶ fails to detect the leading edge of a sheet. The postfuser transport rollers ❷ push the sheet up the exit paper path into the exit sensor and rollers ❸.

Figure 6–19 Exit Leading Edge Jam

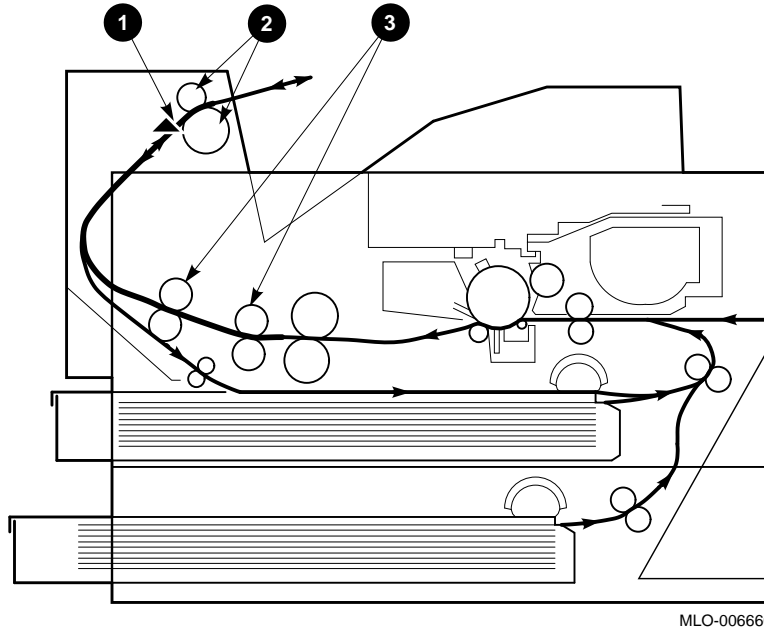

**Troubleshooting:** Figure 6–20 is the exit sensor wiring diagram. Perform the following procedure:

1. Open the exit door and inspect the paper path for damage or obstructions.
2. Make sure the top part of the postfuser transport closes and locks. When the exit door closes, it pushes the levers that grab and lock the upper plate of the postfuser transport.
3. Test the exit sensor by entering the 1701 test code 0812. If the test fails, do the following:
  - Inspect the 3-pin plug that connects the sensor to the driver board.
  - Inspect the 20-pin plug that connects P/J56 on the driver board to P/J47 on the DC control board.
  - Swap the exit sensor.

## 6.7 1025 CLEAR PAPER PATH

- Swap the DC control board.
- Swap the driver board

Figure 6–20 Exit Sensor

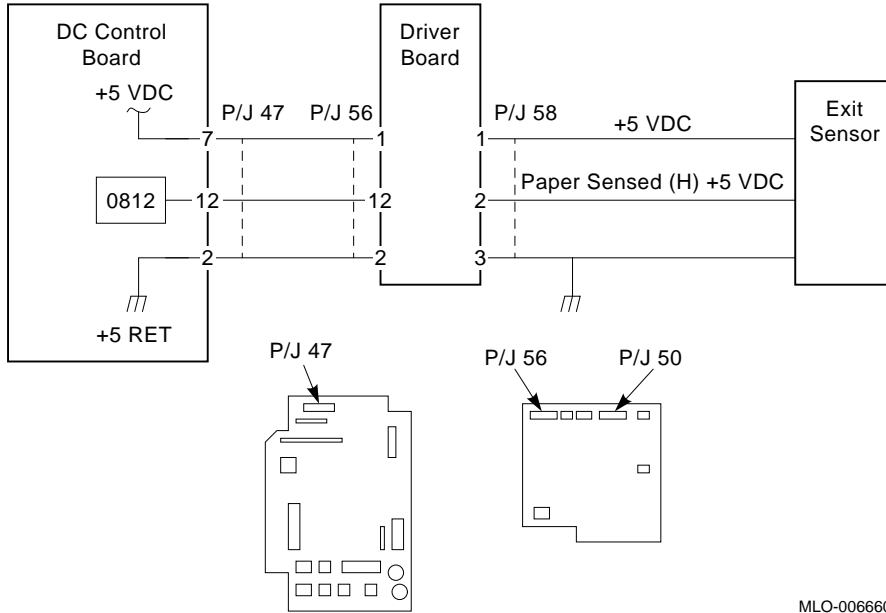

MLO-006660

## 6.8 1026 CLEAR PAPER PATH

**Description:** This error is displayed when the exit sensor ❶ fails to detect the trailing edge of the sheet. The exit rollers ❷ pull the sheet over the sensor linkage and eject it into the output stack ❸.

Figure 6–21 Exit Leading Edge Jam

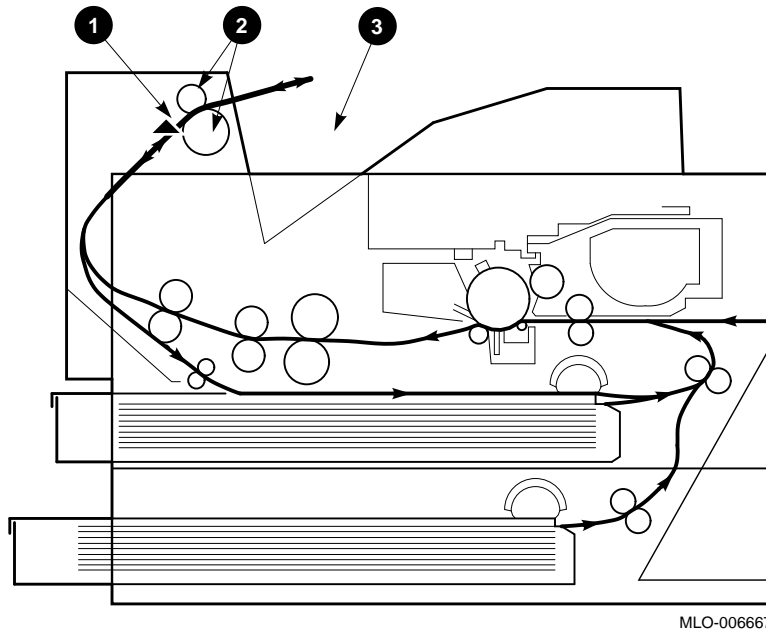

**Troubleshooting:** Figure 6–22 is the exit motor wiring diagram. Perform the following procedure:

1. Inspect the exit pinch roller pressure springs. Make sure the springs are installed and are applying firm, even pressure.
2. If the surface of either exit roller is dirty, glazed, or oily, replace the roller.
3. Test the exit sensor by entering the 1701 test code 0812. Do the following if the test fails:
  - Inspect 3-pin plug that connects the sensor to the driver board.
  - Inspect the 20-pin plug that connects P/J56 on the driver board to P/J47 on the DC control board.
  - Swap the DC control board.

## 6.8 1026 CLEAR PAPER PATH

- Swap the driver board.
- Swap the exit sensor assembly.

**Figure 6–22 Exit Motor**

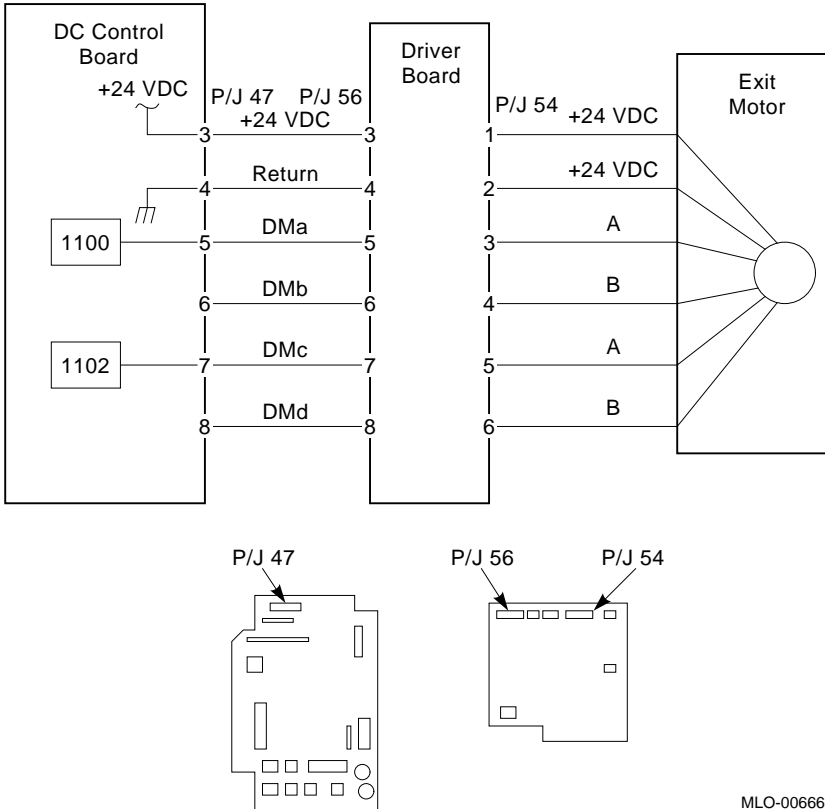

MLO-006661

## Image Defects FIPs

As Figure 7–1 shows, this chapter includes the fault isolation procedures (FIPs) for image defects. Figure 7–1 shows how Chapter 7 fits into the overall troubleshooting flow. If you follow a sequence of steps to fix one problem, return to Section 4.1, Start FIP.

**Figure 7–1 Overall Troubleshooting Flow**

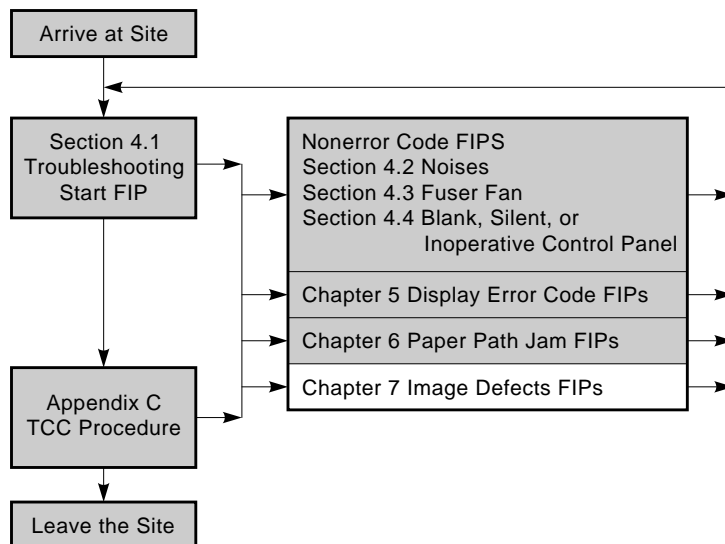

MLO-007646

## 7.1 Image Defect Lookup

### 7.1 Image Defect Lookup

**Note:** Always perform the start FIP in Section 4.1 before using the FIPs in this chapter.

If by examining the test sheets or customer's copy you that find the printed image is defective, look up the image defect in Table 7-1 and go to the indicated FIP.

**Table 7-1 Image Defect Lookup**

<b>FIP</b>	<b>Defect Description</b>
Section 7.2	Background Staining
Section 7.3	Black Prints
Section 7.4	Blank Prints
Section 7.5	Damaged Prints
Section 7.6	Deletions, Blank, or White Spots
Section 7.6.1	Vertical Deletions or White Bands
Section 7.6.2	Horizontal Deletions or White Bands
Section 7.6.3	Random or Localized White Spots
Section 7.7	Extraneous Marks
Section 7.8	Light Images
Section 7.9	Misregistration
Section 7.10	Skewed Image
Section 7.11	Residual Image
Section 7.12	Black Spots
Section 7.13	Fusing Failure
Section 7.14	Black Lines or Streaks

### 7.2 Background Staining

**Description:** A degree of darkness or contamination overall or localized in the white areas of the print. Figure 7–2 is an example of background staining.

**Troubleshooting:** Test the degree of staining by printing one or more copies of the 1948 Setup pattern, as shown in Section 3.3. Turn the green density adjusting knob fully clockwise and then counterclockwise printing several test patterns at each extreme. Inspect the gray or background areas of both prints. No staining should occur. A slight density change will be noticeable.

- If you see no change in density, go to Section 7.15, HVPSA FIP.
- If the background stains run in bands across the print and are approximately 4.92 in. (125mm) apart, the photosensitive print drum might be damaged. If background staining is evident perform the following procedure:
  1. Swap the print cartridge.
  2. Swap the developer cartridge.
  3. Clean and swap the transfer/separation charger.
  4. Perform all the steps in Section 7.17, Developer Bias FIP.

## 7.2 Background Staining

Figure 7-2 Background Staining

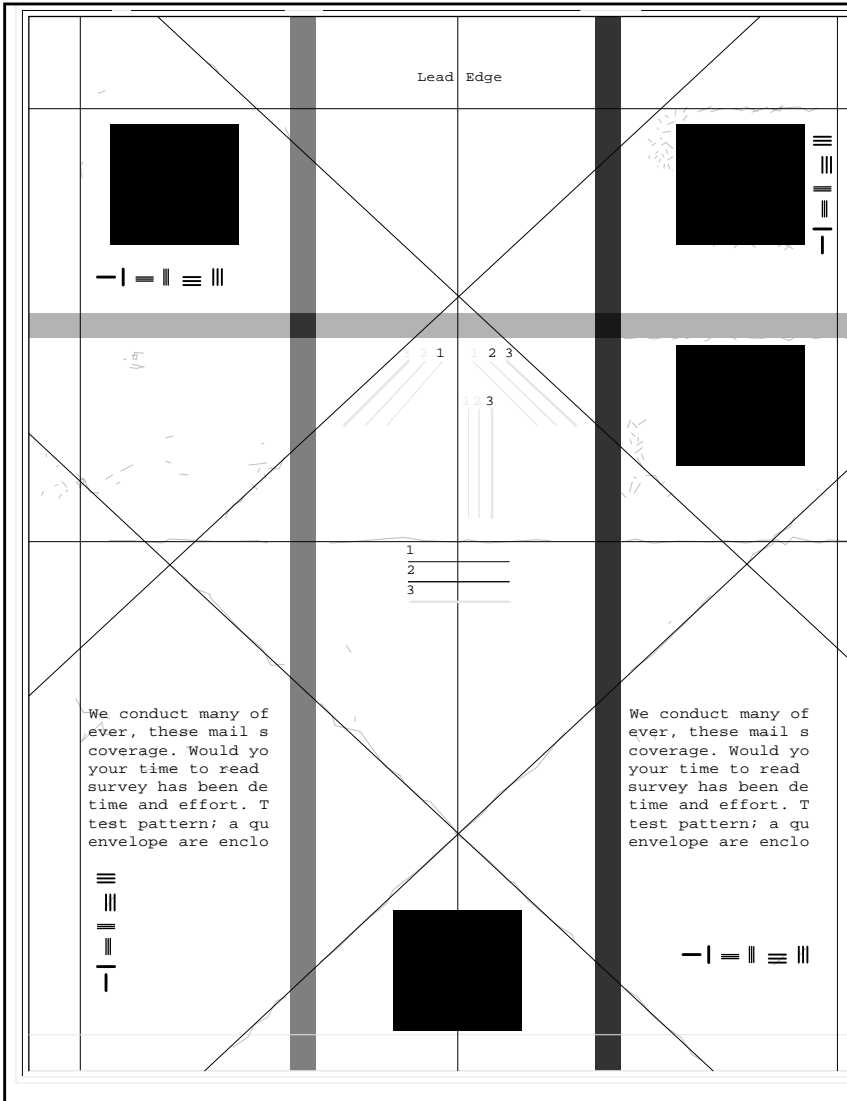

MLO-006670

## 7-4 Image Defects FIPs

## 7.3 Black Prints



**Description:** The print is completely black.

**Troubleshooting:** Print one copy of the 1948 Setup pattern, as shown in Section 3.3 and the grid test pattern, as shown in Section 3.3. Inspect both test prints for the following:

- If both prints are completely black, go to Section 7.15, HVPSA FIP.
- If any image is visible, go to Section 7.2, Background Staining.
- If either one of the two prints is completely black, do the following procedure:
  1. Disconnect the 26-pin plug that connects to P37 on the DC control board.
  2. Print the grid test pattern.
    - If the pattern is all black, replace the DC control board.
    - If the print is not all black, do the following:
      - Swap the video control board.
      - Replace the 26-pin cable harness that connects P37 on the DC control board to J2 on the video control board.

## 7.4 Blank Prints

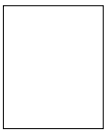

**Description:** The entire sheet is blank.

**Troubleshooting:** Print and inspect one copy of each 1948 Setup pattern, as shown in Section 3.3 and the the grid test pattern, as shown in Section 3.3. Perform the following procedure:

1. If the printed image is too light, go to Section 7.8, Light Images.
2. If only the 1948 Setup pattern is blank, do the following:
  - Swap the video control board.
  - Replace the 26-pin cable harness that connects P37 on the DC control board to J2 on the video control board.

## 7.4 Blank Prints

3. Remove and inspect the developer cartridge for the following:
  - Press down the blue handle of the spring loaded developer drive gear mechanism. The return spring should offer a firm resistance and when released, must return to its starting point.  
If you feel sticking, binding, or see any damage, replace the main motor and gear assembly.
  - Turn the gear that rotates the magnetic developer roller. If you feel or see any binding or damage, replace the developer unit.
  - If the toner is unevenly distributed over the surface of the magnetic roller, replace the developer unit.
4. Inspect the condition of the following scanner assembly components:
  - Check the 12-pin plug that connects the scanning assembly to the wire harness to P36 on the DC control board.
  - Tighten the screw that connects the two ground wire ring connectors to the metal shield of the scanning assembly.
  - Make sure the scanning assembly is correctly mounted and screwed down.
  - Remove the print cartridge and inspect the window on the bottom of the scanning assembly. Make sure there are no obstructions in the path of the laser beam.
5. Inspect the print drum ground clips. When the top door is closed, this clip connects the metal print drum axle to the frame of the printer.  
Use an ohmmeter to measure the resistance between the metal part of the print drum and the frame of the printer. If the resistance is greater than  $10\Omega$ , replace the ground clip.
6. Perform all the steps in Section 7.17, Developer Bias FIP.
7. Perform all the steps in Section 7.15, HVPSA FIP.

### 7.5 Damaged Prints

**Description:** The printed sheet is wrinkled, torn, folded over, dog-eared or otherwise damaged.

**Troubleshooting:** Use the following procedure to isolate the faulty component:

1. Inspect the cassette and paper for the following:
  - Weight and type of paper.
  - Paper might be damp. Try some dry paper from the center of a fresh package.
  - Paper might be compressed. Remove and fan the paper.
  - Make sure the paper is correctly loaded under the snubbers.
  - Top cover of the printer, only if duplex refeeding.
2. Inspect the following paper path components:
  - All paper guides, rollers, transport assemblies. Look for warped covers, adhesives contamination, wadded shreds of paper, and so on.
  - Make sure the transfer/separation charger is fully seated and locks into place.
  - Make sure all transports are correctly seated and aligned.
3. Inspect the following pinch roller pressure springs:
  - Upper and lower turn rollers on the feed door
  - Upper registration roller
  - Lower (pressure) fuser roller
  - Postfuser transport rollers
  - Refeed rollers (if duplex feeding)
  - Exit pinch roller
4. Inspect the following fuser components:
  - Make sure the rear cooling fan is operational, as shown in Section 4.3.
  - Paper might be wrapped around one of the fusing rollers.
  - Upper or lower stripper fingers might be damaged.
  - Lower fuser roller might be swollen.

## 7.6 Deletions, Blank, or White Spots

### 7.6 Deletions, Blank, or White Spots

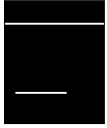

**Description:** Toner is missing from dark areas of the print. Might appear as vertical, horizontal, or as blotchy white spots.

**Troubleshooting:** Print one copy of each of 1948 Setup pattern, as shown in Section 3.3 and the grid test pattern, as shown in Section 3.3. Also, ask the customer for print samples.



Inspect the prints and classify the image defect. Go to one of the following procedures:

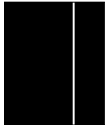

- Section 7.6.1, Vertical Deletions or White Bands
- Section 7.6.2, Horizontal Deletions or White Bands
- Section 7.6.3, Random or Localized White Spots

#### 7.6.1 Vertical Deletions or White Bands

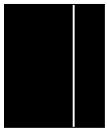

**Description:** Bands of white running across the sheet vertically, from leading to trailing edge. Perform the classification procedure in Section 7.6.

**Troubleshooting:** Suspect bad paper, consumables, paper path damage, or light path obstructions: Perform the following procedure:

1. The toner might be damp and caked. Remove the developer cartridge with toner cartridge installed. Gently rock and tap the developer unit to evenly distribute the toner within the cartridge.
2. The paper might be damp. Try some dry paper from the center of a fresh package.
3. Remove print cartridge and inspect the following areas:
  - Look for any obstructions in the path of the laser beam or erase LEDs (for example, dust or lint fibers).
  - If you find moisture on the scanner window, make sure the rear cooling fan is operational, as shown in Section 4.3. If the window is scratched or stained, replace the scanner assembly.
  - Make sure there are no obstructions between the developer and print cartridge.
4. Clean or swap the transfer/separation assembly.

## 7.6 Deletions, Blank, or White Spots

5. Remove the developer unit and inspect the distribution of toner on the developer roller. You can manually turn the roller clockwise.
6. Look for burrs or scratches on the registration or postfuser paper path guides.
7. Inspect the fuser rollers for scratches or damage.
8. Inspect the upper and lower fuser stripper fingers.
9. Swap the fuser unit.
10. Swap the developer cartridge.
11. Swap the print cartridge.

### 7.6.2 Horizontal Deletions or White Bands



**Description:** One or more bands of white running horizontally across the sheet. Perform the classification procedure, as shown in Section 7.6.

**Troubleshooting:** Suspect rollers or any horizontal component. Perform the following procedure:

1. Remove, clean, and inspect the transfer/separation charger.
2. Go to Section 7.16 and verify the operation of the erase LEDs.
3. Remove the developer unit and inspect the developer roller. Turn the developer roller clockwise to check for sticking or binding. Make sure toner is distributed evenly around the circumference of the roller.
4. Replace or swap the developer unit.
5. Go to Section 4.5, Erratic Operation.

## 7.6 Deletions, Blank, or White Spots

### 7.6.3 Random or Localized White Spots



**Description:** Random or clusters of white spots or large blotchy white areas.

**Troubleshooting:** Perform the classification procedure, as shown in Section 7.6. Perform the following procedure:

1. The paper might be damp. Try some dry paper from the center of a fresh package.
2. If the spots occur at intervals of approximately 4.92 in (125 mm) the photoreceptor may be damaged.
3. Inspect the heat and pressure rollers for contamination or damage. Swap the fusing unit.

## 7.7 Extraneous Marks



**Description:** Horizontal or vertical bands or other marks.

**Troubleshooting:** Print copies of the grid test pattern, as shown in Section 3.3 and the 1948 Setup pattern, as shown in Section 3.3. Also, ask the customer to print samples of the offending defect.

Analyze the printed samples and go to one of the following:

1. If the defect appears on the grid pattern, inspect the print drum ground clips. When the top door is closed, this clip connects the metal print drum axle to the frame of the printer.  
Use an ohmmeter to measure the resistance between the metal part of the print drum and the frame of the printer. If the resistance is greater than 10 $\Omega$ , replace the ground clip.
2. If the defect appears on the 1948 Setup pattern, swap the video control board.
3. If the defect appears on the customer samples, do the following:
  - a. Ask the customer if the system has been recently reconfigured.
  - b. Try different fonts. The downline loaded font data from the host might be bad.

## 7.7 Extraneous Marks

- c. Make sure the communication features of the printer match those of the host system and any intermediate data communication equipment, (modems, multiplexers, and so on).

## 7.8 Light Images

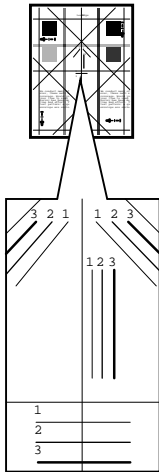

**Description:** The print is completely black or the overall image density is too light or undertoned.

**Troubleshooting:** Print several copies of the 1948 Setup pattern, as shown in Section 3.3. Inspect the test patterns. All of the number 1 lines must be visible and unbroken. Perform the following procedure to fix any defects:

1. The paper might be damp. Try some dry paper from the center of a fresh package.
2. Make sure the rear cooling fan is operational, as shown in Section 4.3.
3. If you find moisture on the scanner window, make sure the rear cooling fan is operational, as shown in Section 4.3.
4. Clean or swap the transfer/separation charger.
5. Inspect the print drum ground clips. When the top door is closed, this clip connects the metal print drum axle to the frame of the printer.

Use an ohmmeter to measure the resistance between the metal part of the print drum and the frame of the printer. If the resistance is greater than  $10\Omega$ , replace the ground clip.

6. Perform Section 7.15, HVPSA FIP.
7. Perform Section 7.17, Developer Bias FIP.
8. Swap the following FRUs:
  - Developer unit
  - Print cartridge
  - Scanner assembly

## 7.9 Misregistration

### 7.9 Misregistration

**Description:** If the image is not positioned in the center of the sheet, but is parallel to the edges of the sheet, a misregistration problem exists.

**Troubleshooting:** Print several copies of the grid test pattern, as shown in Section 3.3 and mark the leading edge. If the image is skewed (image is not parallel to the edge of the sheet) go to Section 7.10.

Refer to Figure 7–3 and measure registration to the following specifications:

- ① The vertical registration must be  $3.0 \pm 2$  mm at the leading edge of the simplex or duplex side.
- ② The horizontal registration must be  $3.0 \pm 2.5$  mm simplex side or  $3.0 \pm 4.0$  mm on the duplex side.

If the image is not centered on the test sheet, perform the following procedure:

- The paper might be compressed. Remove and fan the paper.
- The cassette and the metal corner snubbers. Make sure the paper is correctly loaded under the snubbers.
- Swap the paper cassette.
- Check the registration transport paper guides for adhesives contamination, wadded shreds of paper, and so on.
- Make sure the transfer/separation charger is fully seated and locked into place.
- Check the springs that apply pressure to the upper turn pinch rollers. The upper pinch roller is mounted on the feed door.
- If the vertical registration varies between prints, the registration clutch might be bad.
- Perform the horizontal or vertical registration adjustment, as shown in Section 10.3 and Section 10.4.
- If the registration adjustment was ineffective, swap the DC control board.

## 7.9 Misregistration

Figure 7-3 Misregistration Grid Pattern

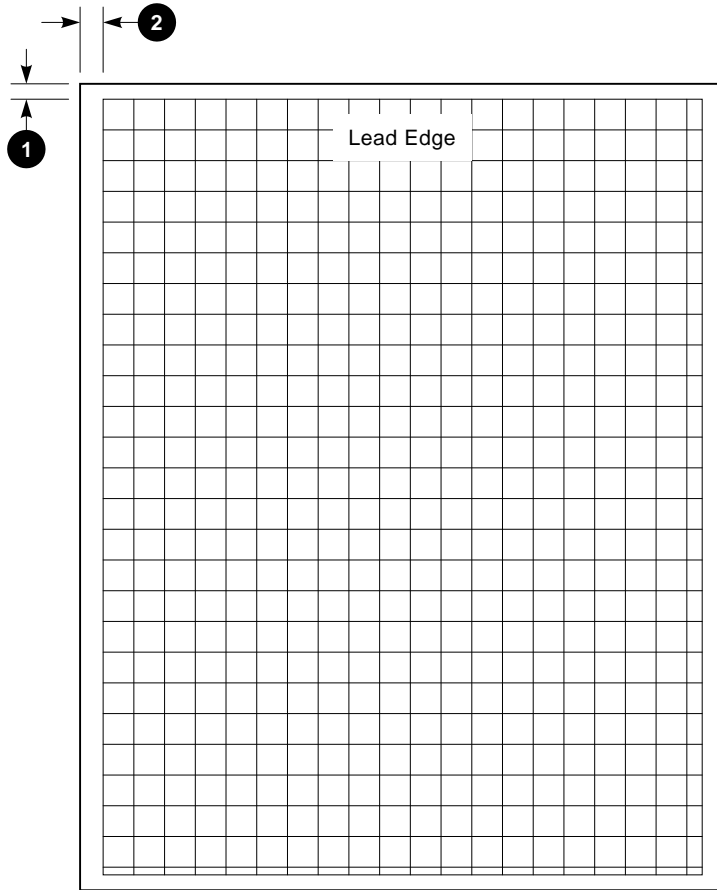

MLO-006673

## 7.10 Skewed Image

### 7.10 Skewed Image

**Description:** The image is not parallel to the edge of the sheet.

**Troubleshooting:** To measure the skew, print several duplex copies of the grid test pattern, as shown in Section 3.3, and mark the leading edge. Take measurements ❶ and ❷ from the location shown in Figure 7-4. On the simplex side, the measurements must be within 1.6 mm of each other. On the duplex side, the measurements must be within 1.8 mm of each other.

If the image is skewed on the sheet, perform the following procedure:

1. Check all paper guides, rollers, transport assemblies. Look for warped covers, adhesives contamination, wadded shreds of paper, and so on.
2. Make sure the transfer/separation charger is fully seated and locks into place.
3. Make sure all transports are correctly seated and aligned.
4. If the skewing only occurs when feeding from the LCIT, check the tray parallelism, as shown in Section 11.3.
5. Inspect the following pinch roller springs:
  - Upper and lower turn pinch rollers on the feed door
  - Upper registration roller
  - Lower (pressure) fuser roller
  - Postfuser transport rollers
  - Refeed rollers (if duplex feeding)
  - Exit pinch roller
6. Make sure the scanner assembly is properly mounted and seated.
7. Do the following if the skew occurs when feeding from one cassette;
  - a. The paper might be compressed. Remove and fan the paper.
  - b. Make sure the paper is correctly loaded under the metal corner snubbers.
  - c. Make sure the snubbers are not bent and are free of burs.
  - d. Inspect the pressure and side plates for damage and proper alignment.
  - e. Swap the cassette.
  - f. Clean or swap the feed roller. See Section 10.5, Feed Roller Cleaning Procedure.

## 7.10 Skewed Image

8. Make sure the exit and feed doors are undamaged and mounted correctly.

**Figure 7-4 Skew Measurement**

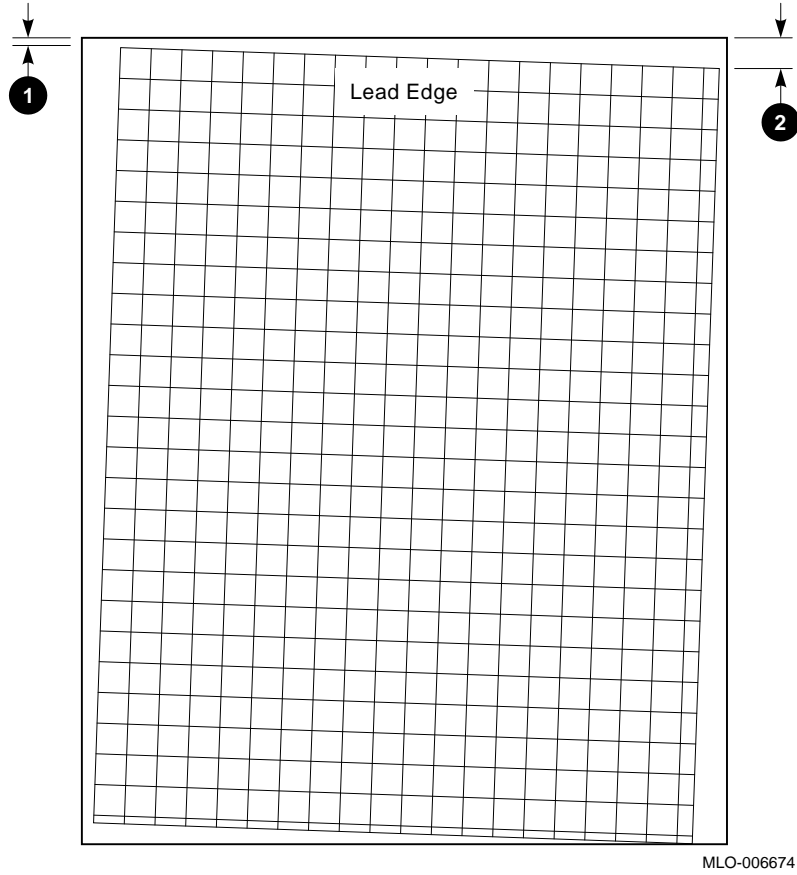

## 7.11 Residual Image

### 7.11 Residual Image

**Description:** Images from recent prints are dimly printed over the current image. This can be caused by poor print drum or fusing roller cleaning or by a damaged heat roller.

**Troubleshooting:** Print several copies of the 1948 Setup pattern, as shown in Section 3.3. Use the following procedure if you see residual images:

1. Make sure the paper or any special stock meets specification listed in Appendix B.
2. Inspect and clean both registration rollers.
3. Make sure a fuser cleaning pad is installed. Remove and inspect the fuser cleaning pad.
4. Inspect and clean the prefuser transport roller.
5. If the defect occurs at intervals of approximately 4.92 in (124mm), replace the print cartridge.
6. If the defect occurs at intervals of approximately 3.75 in (95mm), replace the fusing unit.
7. Go to Section 7.16 and verify the operation of the erase LEDs.

### 7.12 Black Spots

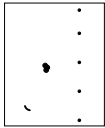

**Description:** Random or sequential black spots in the white areas of the print. Black spots are caused by leaking toner, a damaged roller, or by the failure of some cleaning process. The following specifications applies to spots:

- Spots must be no larger than 0.5 mm.
- There must be no more than one spot measuring between 0.4–0.5 mm on any print.
- Any spot less than 0.25 mm, is acceptable.

**Troubleshooting:** Print several copies of the light dusting test pattern, as shown in Section 3.3. If black spots are present, perform the following procedure:

1. Make sure a fuser cleaning pad is installed. Remove and inspect the cleaning pad for damage or contamination.
2. Go to Section 7.16 and verify the operation of the erase LEDs.

## 7.12 Black Spots

3. The distance between repeating spots indicates which roller caused the defect. Measure the distance between the spots and see if it compares to the distances below. Inspect the indicated rollers or inspect all paper path rollers for damage or contamination.

Component	Millimeters	Inches
Registration rollers	44.0	1.73
Fusing pressure roller	79.0	3.11
Fusing heat roller	95.0	3.74
Print drum	125.0	4.92
Developer	56.0	2.2

4. Swap the print drum cartridge.
5. Remove the developer unit and inspect the developer roller. Turn the developer roller clockwise to check for sticking or binding. Make sure toner is distributed evenly around the circumference of the roller.
6. Swap the developer unit.

## 7.13 Fusing Failure

**Description:** Fusing failure is indicated when you can brush or rub the toner off the sheet.

**Troubleshooting:** Print several copies of the grid test pattern, as shown in Section 3.3. Use the following procedure if fuser failure is evident:

1. Make sure the paper or any special stock meets specifications listed in Appendix B. Fusing problems occur when printing on extremely rough, heavily textured, or high rag content papers.
2. The paper might be damp. Try some dry paper from the center of a fresh package.
3. Make sure the rear cooling fan is operational, as shown in Section 4.3.
4. Inspect the following fuser components:
  - Paper might be wrapped around one of the fusing rollers.
  - Heat or pressure roller might be damaged or swollen.

## 7.13 Fusing Failure

- Pressure roller tension arms and springs might be damaged or not working.

## 7.14 Black Lines or Streaks

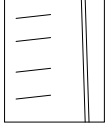

**Description:** Black lines or streaks running horizontally or vertically in the white areas of the sheet.

**Troubleshooting:** Print several copies of the light dusting test pattern, as shown in Section 3.3. The light dusting test print should be completely white. Classify the streaks as horizontal or vertical running and go to one of the following procedures:

- Procedure for vertical lines or streaks:
  - a. Remove and inspect the print cartridge. Look for obstructions in the laser beam path. For example: paper, lint, or dust.
    - Swap the print cartridge.
    - Make sure the scanner window is not contaminated or blocked.
    - Make sure the scanner assembly is correctly mounted.
    - Swap the scanner assembly.
  - b. Remove the developer unit and inspect the developer roller. Turn the developer roller clockwise to check for sticking, binding, or toner build up at the ends of the developer roller.
  - c. Swap the developer cartridge.
  - d. Make sure a fuser cleaning pad is installed.
  - e. Remove and inspect the fuser cleaning pad. Replace it if damaged or contaminated.
  - f. Inspect and clean the fuser stripper fingers.
- Procedure for horizontal streaks:

The distance between horizontal lines indicates which roller caused the defect. Measure the distance and see if it compares to the distances below. Inspect the indicated rollers or inspect all paper path rollers for damage or contamination.

## 7.14 Black Lines or Streaks

Component	Millimeters	Inches
Registration rollers	44.0	1.73
Fusing pressure roller	79.0	3.11
Fusing heat roller	95.0	3.74
Print drum	125.0	4.92
Developer	56.0	2.2

## 7.15 HVPSA FIP

**Description:** Use the following FIP if one or more of the HVPSA voltages malfunction or if directed here from some other FIP:

1. Inspect or replace the transfer/separation charger for any of the following reasons:
  - If the charge wire is broken, shorted to ground, or otherwise damaged
  - If the ground springs are damaged
  - If the transfer/separation has any physical damage
2. Inspect the following high-voltage contacts:
  - The transfer/separation wires and connector block
  - The primary high-voltage connector (see Section 9.17.1) that connects the print cartridge to the HVPSA.
  - The developer bias connector (see Section 9.17.3) that connects the developer roller to the HVPSA.
3. Swap the following:
  - Print cartridge. To see if the primary charger is malfunctioning.
  - Transfer/separation charger.
  - Developer unit. The developer roller might be shorted.
  - HVPSA. (A circuit diagram is provided in Figure 7–5.)
  - DC control board

**Warning:** Use extra caution when working about the low-power, high-voltage supplies of the HVPSA. Do not attempt to measure the high-voltage output of the HVPSA.

## 7.15 HVPSA FIP

Figure 7-5 HVPSA

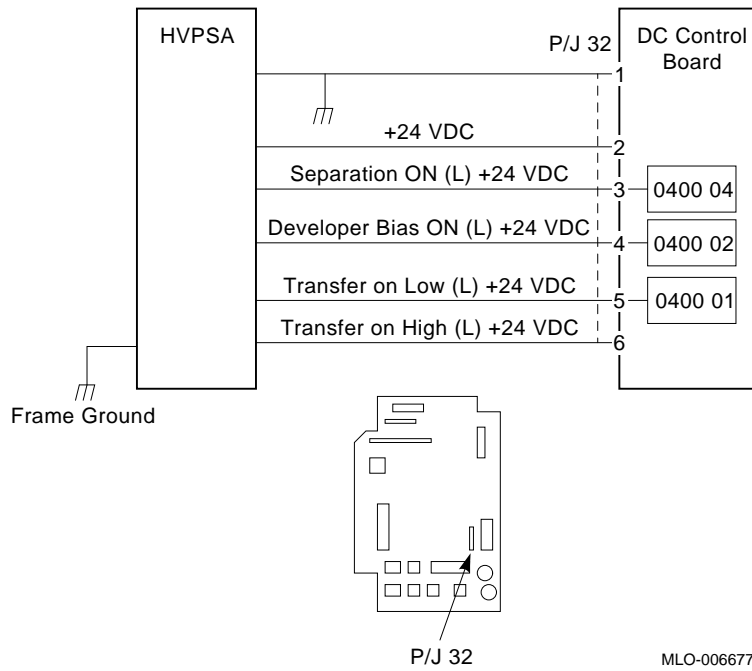

MLO-006677

## 7.16 Erase FIP

**Description:** Use the following FIP if one or more of the erase LEDs fail to light or if directed here from some other FIP:

1. Remove the following parts:
  - a. Print drum, as shown in Section 9.11
  - b. Top door cover, as shown in Section 9.2
2. Test the leds by entering the 1701 Test code 0400.00.
3. Inspect the P/J81 connector that connects the erase board to P/J36 of the DC control board. (Figure 7-6 is the erase circuit diagram.)
4. Swap the following if any of the LEDs fail to light:
  - Erase board

- DC control board

Figure 7–6 Erase LEDs Diagram

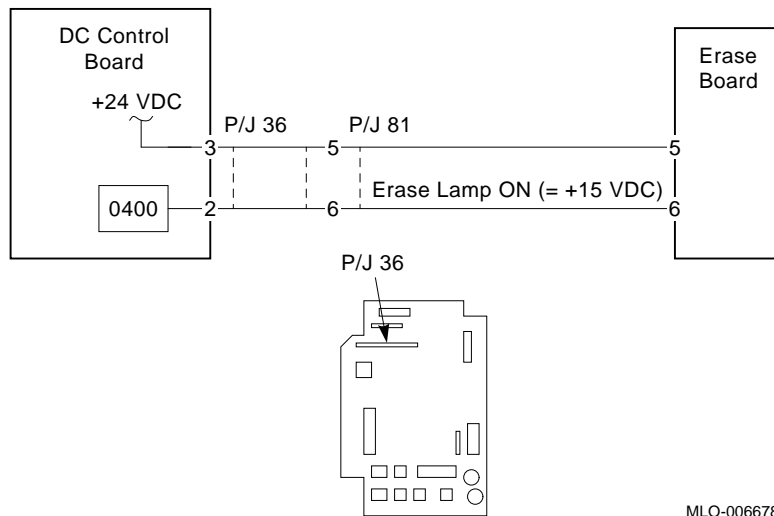

## 7.17 Developer Bias FIP

**Description:** Use the following FIP when directed here from some other FIP:

1. Remove the developer unit, as shown in Section 9.12.
2. Inspect and clean the following. Replace any part that is bent, pitted, or otherwise damaged.
  - Spring contacts at the front and rear end of the developer roller shaft.
  - Developer bias connector connects the developer roller to the HVPSA. See ❶, in Figure 7–7 for its location. See Section 9.17.3 for the removal and replacement procedure.
  - Top left coil spring connector of the HVPSA.
  - Spring contacts that ground the top door to the rear bulkhead when the top door closes.

## 7.17 Developer Bias FIP

- P/J81 connector that connects the erase board to P/J36 of the DC control board.

**Figure 7-7 Developer Bias Connector**

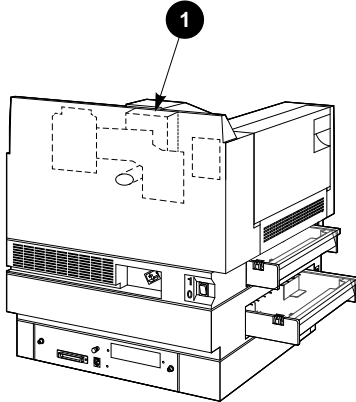

MLO-006679

---

## RSL and Parts Location

This chapter contains the recommended spares lists (RSL) and illustrations for locating parts and connectors. Section 8.1 is a list of parts and part numbers. Section 8.2 provides a way to identify a part from its location in the printer. Section A.4 shows the location of connectors and plugs.

### 8.1 Recommended Spares List

Table 8–1 identifies the spare parts that are stocked for servicing the printer. For LCIT spare parts, see Table 8–2. If you need a part that is not on the RSL, consult the *DEClaser 3200 Illustrated Parts Breakdown* for the part number or order information.

**Table 8–1 DEClaser 3200 Recommended Spares List (RSL)**

Part Number	R/R Procedure	Part Description
22–01341–01	NA	Miscellaneous parts kit
29–29775–01	Section 9.6	Right side cover
29–29704–01	Section 9.7	Right cover (feed door)
29–29238–01	Section 9.8	Exit door
LNO8X–AB	Section 9.11	Photoreceptor (print) drum
LNO8X–AC	Section 9.12	Developer kit with transfer/separation charger and toner cartridge
LNO8X–AA	Section 9.13	Toner cartridge
29–29308–01	Section 9.14	Video control board with no attached options
LN08X–PS	Section 9.14.1	PDL board
LN08X–UD	Section 9.14.2	Coprocessor SIM

(continued on next page)

## 8.1 Recommended Spares List

**Table 8–1 (Cont.) DEClaser 3200 Recommended Spares List (RSL)**

<b>Part Number</b>	<b>R/R Procedure</b>	<b>Part Description</b>
LN08X-UC	Section 9.14.3	Expansion memory SIMs
29–29271–01	Section 9.15	DC control board
29–29726–01	Section 9.15.2	Page count memory
29–29249–01	Section 9.16	115 Vac LVPSA
29–29250–01	–	220 Vac LVPSA
29–29251–01	Section 9.17	HVPSA
29–29270–01	Section 9.18	Drive board
12–36594–01	Section 9.20	Video cooling fan
29–29269–01	Section 9.21	Developer interconnect board
12–365930–01	Section 9.22.1	Fuser fan
29–29248–01	Section 9.22.2	Control panel
29–29246–01	Section 9.23	Scanner assembly
29–29273–01	Section 9.24	Top door (scanner) interlock sensor
29–29257–01	Section 9.25	Transfer/separation charger
29–29256–01	Section 9.26	Erase board
29–29236–01	Section 9.27	Registration transport assembly
29–29306–01	Section 9.28	115 Vac fusing unit and print drum ground clips.
29–29307–01	–	220 Vac fusing unit and print drum ground clips.
29–29247–01	Section 9.28.1	Fuser cleaning pad
29–29244–01	Section 9.29	Prefuser transport
29–29242–01	Section 9.30	Upper postfuser transport assembly
29–29243–01	–	Lower postfuser transport assembly
29–29240–01	Section 9.31	Gate sensor linkage
29–29239–01	Section 9.32	Refeed cover (baffle)
29–29235–01	Section 9.33	Refeed pinch and drive rollers
29–29252–01	Section 9.33	Refeed roller clutch
29–29258–01	Section 9.34	Exit motor
29–29259–01	Section 9.35	Offset motor assembly

(continued on next page)

## 8.1 Recommended Spares List

**Table 8–1 (Cont.) DEClaser 3200 Recommended Spares List (RSL)**

<b>Part Number</b>	<b>R/R Procedure</b>	<b>Part Description</b>
29–29305–01	Section 9.36	Main motor
29–29260–01	Section 9.37	Upper cassette empty sensor
29–29267–01	Section 9.38	Upper size-sensing assembly
29–29260–01	Section 9.39	Lower cassette empty sensor (same as upper cassette empty sensor)
29–29266–01	Section 9.41	Bypass sensor
29–29261–01	Section 9.42	Exit sensor
29–29263–01	Section 9.43	Refeed sensor
29–29273–01	Section 9.44	Feed-door sensor (interlock switch)
29–29264–01	Section 9.45	Exit-door sensor (interlock switch)
29–29265–01	Section 9.46	Registration sensor
29–29262–01	Section 9.47	Tray-full sensor
29–29237–01	Section 9.48	Exit pinch roller assembly
29–29705–01	Section 9.49	Exit drive roller
29–29272–01	Section 9.50	Upper or lower feed roller/clutch
29–29254–01	Section 9.51	Upper feed solenoid
29–29272–01	Section 9.52	Lower feed roller/clutch
29–29255–01	Section 9.52	Lower feed solenoid
29–29241–01	Section 9.53	Lower turn drive roller and chute assembly
29–29253–01	Section 9.53	Lower turn roller clutch

## 8.1 Recommended Spares List

### 8.1.1 LCIT Recommended Spares List

Table 8–2 identifies the spare parts that are stocked for servicing the large-capacity input tray (LCIT). For printer spare parts, see Table 8–1.

**Table 8–2 LCIT Recommended Spares List (RSL)**

<b>Part Number</b>	<b>R/R Procedure</b>	<b>Part Description</b>
29–29706–01	Section 11.4.4	Elevator motor
29–29707–01	Section 11.4.5	Feed motor
29–29708–01	Section 11.4.6	Control board
29–29712–01	Section 11.4.7	Paper out sensor (switch)
	Section 11.4.8	Lower limit switch
	Section 11.4.9	Upper limit switch
29–29710–01	Section 11.4.10	Door switch
29–29711–01	Section 11.4.11	Paper feed rollers

## 8.2 Parts Locator

### 8.2 Parts Locator

Use Figure 8–1, Figure 8–2, and Figure 8–3 to identify the location of a part by the name that is listed in the accompanying table.

Figure 8–1 Covers, Doors, and External Parts

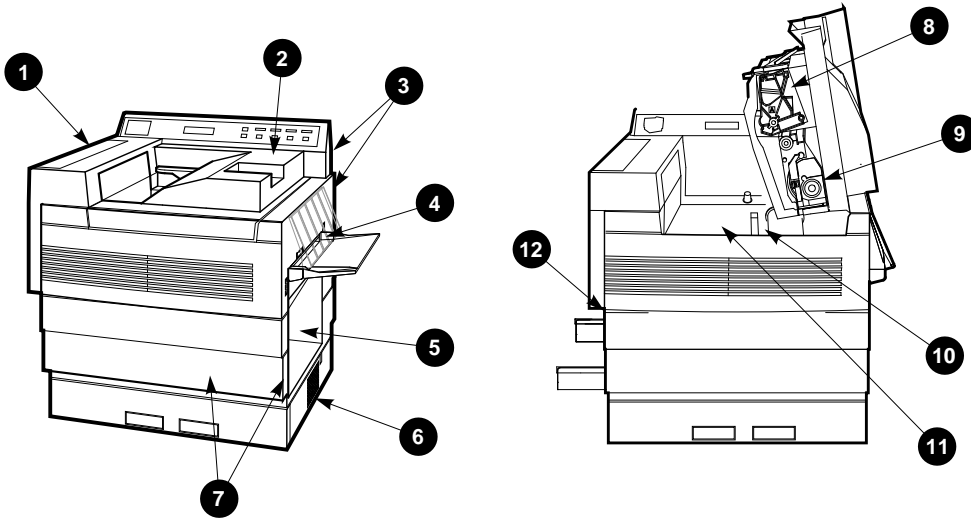

MLO-006681

Table 8–3 Covers, Doors, and External Parts

<b>Figure 8–1 Left</b>	
<b>Part</b>	<b>Removal and Replacement Procedure</b>
❶ Exit door postfuser transport	Section 9.8 Section 9.30 (The postfuser transport is behind the exit door.)
❷ Top door cover	Section 9.2
❸ Upper cover	Section 9.3
❹ Right side cover	Section 9.6 (The cover is behind the manual feed guide.)
❺ Feed door	Section 9.7
❻ Lower front Cover	Section 9.5
❼ Video cooling fan	Section 9.20
<b>Figure 8–1 Right</b>	
❽ Photoreceptor (print) drum	Section 9.11
❾ Developer unit toner cartridges	Section 9.12 Section 9.13
❿ Registration transport assembly	Section 9.27
transfer/separation charger	Section 9.25
⓫ Prefuser transport	Section 9.29
⓬ Refeed cover	Section 9.32

## 8.2 Parts Locator

Figure 8-2 Parts Locator 1

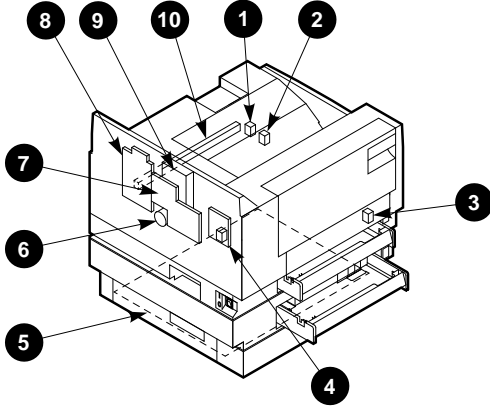

MLO-006682

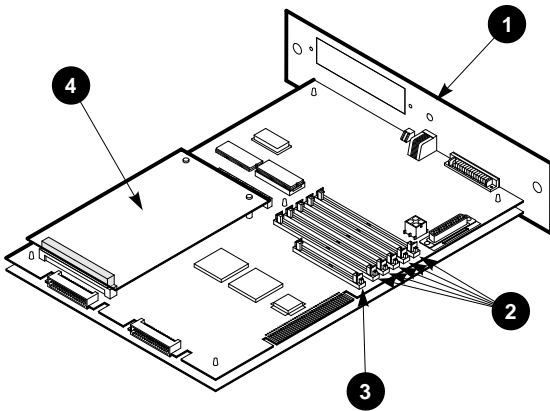

MLO-007471

<b>Figure 8–2 Upper</b>	
<b>Part</b>	<b>Removal and Replacement Procedure</b>
① Bypass sensor	Section 9.41
② Registration sensor	Section 9.46
③ Refeed sensor	Section 9.43
④ Drive board gate sensor	Section 9.18 Part of drive board
⑤ Video control board	See Lower Figure 8–2 for more detail
⑥ Main motor	Section 9.36
⑦ LVPSA	Section 9.16
⑧ DC control board	Section 9.15
⑨ HVPSA	Section 9.17
⑩ Developer interconnect board	Section 9.21

<b>Figure 8–2 Lower</b>	
① Video control board	Section 9.14
② Expansion RAM	Section 9.14.3
③ Coprocessor SIM	Section 9.14.2
④ PDL board	Section 9.14.1

## 8.2 Parts Locator

Figure 8-3 Parts Locator 2

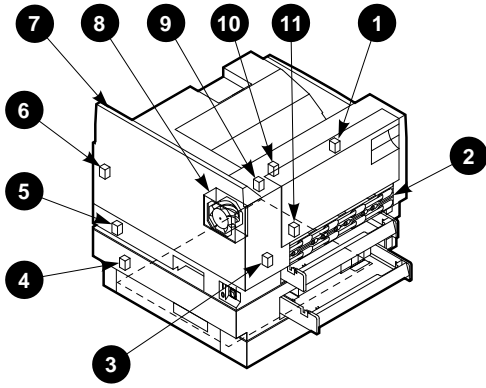

MLO-006684

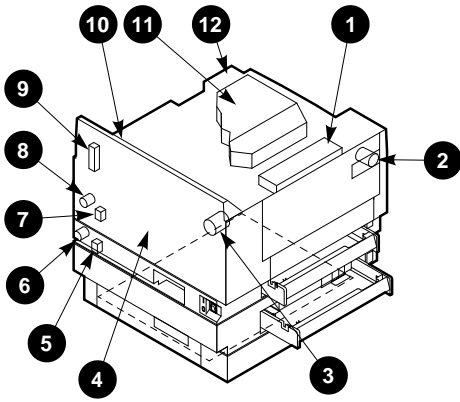

MLO-006683

Table 8–4 Parts Locator 2

<b>Figure 8–3 Upper</b>	
<b>Part</b>	<b>Removal and Replacement Procedure</b>
① Exit sensor	Section 9.42
② Fuser unit	Section 9.28
③ Exit-door sensor	Section 9.45
④ Lower size-sensing assembly	Section 9.40
⑤ Upper size-sensing assembly	Section 9.38
⑥ Feed-door sensor	Section 9.44
⑦ Upper bracket	Section 9.22
⑧ Fuser fan	Section 9.22.1
⑨ Tray-full sensor	Section 9.47
⑩ Upper cassette-empty sensor	Section 9.37
⑪ Lower cassette-empty sensor	Section 9.39
<b>Figure 8–3 Lower</b>	
① Erase board	Section 9.26
② Offset motor assembly	Section 9.35
③ Exit motor	Section 9.34
④ Rear electronics assembly	Section 9.19
⑤ Lower feed roller, clutch, and solenoid	Section 9.52
⑥ Lower turn drive roller and clutch	Section 9.53
⑦ Upper feed solenoid	Section 9.51
⑧ Upper turn clutch	(Part of the registration transport)
⑨ Top door (scanner) interlock sensor	Section 9.24
⑩ Control panel	Section 9.22.2
⑪ Laser/scanner assembly	Section 9.23
⑫ Top door	No procedure

---

## Removal and Replacement Procedures

This chapter contains a removal and replacement procedure for major assemblies, FRUs, and associated components of the DEClaser 3200 printer. See Chapter 8 to locate an FRU and obtain its part number. See Chapter 11 for LCIT removal and replacement procedures.

### 9.1 General

The removal of most FRUs requires the removal of other components. For that reason, a procedural step can refer you to another procedure. For example, to remove the DC control board, you must perform the procedures to remove the upper cover and rear panel.

To remove an FRU, find the procedure and then follow the steps. To replace an FRU, reverse the procedure, unless otherwise noted.

The printer used for the photographs in this book is an engineering prototype. You may notice some cosmetic differences between the printer shown and the printer that you see in the field. These differences include the logos, labels, and colors of the panels and covers.

**Warning:** *Before you disassemble the DEClaser 3200 printer, make sure the power switch is off and the ac line cord is disconnected from the rear of the printer.*

*Never leave the area if the printer is powered on and the covers are removed.*

*Use of controls or adjustment procedures other than those specified in this manual may result in hazardous laser light exposure to yourself or to other persons in the room. The safety information presented in Section 1.1 only applies while the scanner cover is fully installed.*

## 9.2 Top Door Cover

### 9.2 Top Door Cover

The black plastic bag attached to the underside of the top door cover is the print drum storage bag. See Section 9.11 for additional information.

The tang ❶ on the top door cover actuates the interlock switch. The printer will not operate when the top door cover is removed.

Use the following procedure to remove and replace the cover from the top door of the DEClaser 3200 printer:

1. Open the top cover.
2. Remove the two screws that hold the cover to the top door chassis.
3. Lift the cover over the top door handle and remove the top door cover.

MLO-006836

### 9.3 Upper Cover

Use the following procedure to remove and replace the upper cover from the DEClaser 3200 printer:

1. Remove the following parts:
  - a. Print drum, as shown in Section 9.11
  - b. Top door cover, as shown in Section 9.2
  - c. If installed, remove the LCIT and mounting bracket, as shown in Section 9.9
2. Open the exit door. Leave the door open for the remainder of this procedure.
3. Twist and remove the door strap anchor ❶ from the upper cover.
4. Remove the two screws that hold the upper cover to the exit unit chassis.

MLO-006837

### 9.3 Upper Cover

5. Skip this step if an LCIT was removed in step 1c. Remove the two screws that hold the upper cover to the chassis of the right side of the printer.

MLO-006838

### 9.3 Upper Cover

6. Jog, lift, and remove the upper cover from the printer chassis.

MLO-006938

## 9.4 Rear Panel

### 9.4 Rear Panel

Use the following procedure to remove and replace the rear panel from the DEClaser 3200 printer:

1. Remove the following parts:
  - a. Print drum, as shown in Section 9.11
  - b. Top door cover, as shown in Section 9.2
  - c. Upper cover, as shown in Section 9.3
2. Unplug the line cord connector.
3. Remove the line cord from the plastic restraints.
4. Remove the three screws that hold the panel to the rear or the electronics assembly.

MLO-006839

## 9.4 Rear Panel

5. Loosen the two screws that hold the edge of the metal panel to the printer chassis.

MLO-006840

## 9.4 Rear Panel

6. Remove two screws that hold the rear panel to the left and right sides of the printer.

MLO-006841, MLO-006842

## 9.4 Rear Panel

7. Remove the rear panel. You must slightly bend the plastic to remove the panel.

MLO-006843

## 9.5 Lower Front Cover

### 9.5 Lower Front Cover

Use the following procedure to remove and replace the lower front cover from the DEClaser 3200 printer:

1. Remove the following parts:
  - a. Print drum, as shown in Section 9.11
  - b. Top door cover, as shown in Section 9.2
  - c. Upper cover, as shown in Section 9.3
2. Remove the two screws that hold the cover to the left and right ends of the printer.
3. Remove the lower front cover.

MLO-006844

### 9.6 Right Side Cover

Use the following procedure to remove and replace the right side cover from the DEClaser 3200 printer:

1. Remove the following parts:
  - a. Print drum, as shown in Section 9.11
  - b. Top door cover, as shown in Section 9.2
  - c. Upper cover, as shown in Section 9.3
  - d. Lower front cover, as shown in Section 9.5
  - e. Rear Panel, as shown in Section 9.4
2. Remove the right side cover.

MLO-006846

## 9.7 Right Cover (Feed Door)

### 9.7 Right Cover (Feed Door)

Use the following procedure to remove and replace the right cover or feed door from the DEClaser 3200 printer:

1. Remove the following parts:
  - a. Top door and upper covers, as shown in Section 9.2 and Section 9.3
  - b. Rear panel and rear electronics assembly, as shown in Section 9.4 and Section 9.19
  - c. Remove the printer from the lower cassette assembly, as shown in Section 9.10.
  - d. Lower turn roller and clutch, as shown in Section 9.53
2. Remove the screw that holds the green ground (earth) wire to the door.
3. Remove the two screws that hold the hinge blocks to the cassette.

MLO-006847

## 9.7 Right Cover (Feed Door)

4. Close the door until you see the tension relax on the counterbalance springs.
5. Lift and remove the door assembly.

MLO-006848

## 9.8 Left Cover (Exit Door)

### 9.8 Left Cover (Exit Door)

Use the following procedure to remove and replace the left cover or exit door from the DEClaser 3200 printer:

1. Remove the following parts:
  - a. Print drum, as shown in Section 9.11
  - b. Top door cover, as shown in Section 9.2
  - c. Upper cover, as shown in Section 9.3
2. Pinch one of the door hinges and remove the door.

MLO-006849

## 9.9 Large Capacity Input Tray (LCIT) and Mounting Plate

### 9.9 Large Capacity Input Tray (LCIT) and Mounting Plate

Use the following procedure to remove and replace the LCIT from the DEClaser 3200 printer.

1. Power down the printer.
2. Unplug the ground wire ❶.
3. Unplug the 8-pin MMJ type plug ❷ from the side connector of the printer.
4. Lift the LCIT up and off the alignment pins ❸.

MLO-007990

## 9.9 Large Capacity Input Tray (LCIT) and Mounting Plate

5. Remove the two screws, and remove the mounting bracket. The mounting bracket screws are about 2 cm ( $\frac{3}{4}$  in.) long.

MLO-006850

### 9.10 Assembly Separation

Use the following procedure to separate and reattach the printer from the lower cassette feeder of the DEClaser 3200 printer:

1. Remove the following parts:
  - a. Top door cover, as shown in Section 9.2
  - b. Upper cover, as shown in Section 9.3
  - c. Rear panel, as shown in Section 9.4
  - d. Lower front cover, as shown in Section 9.5
  - e. Transfer/separation charger, as shown in Section 9.25
  - f. Rear electronics assembly, as shown in Section 9.19
2. Unplug the following connectors from the DC control board harness. The connectors are color coded for reconnection, but should you inadvertently transpose some connections, consult Table 9–2.
  - 2-pin, red/red, upper feed solenoid
  - 2-pin, black, lower feed solenoid
  - 4-pin, brown, lower size-sensing and tray empty
  - 4-pin, red, upper size-sensing and tray empty
  - 2-pin, brown, lower turn roller clutch

MLO-006851

## 9.10 Assembly Separation

3. Remove the two screws that hold the rear of the printer to the lower cassette assembly.

MLO-006852

## 9.10 Assembly Separation

4. Remove the two screws that hold the front of the printer to the lower cassette assembly.
5. Remove the screw that holds the tab to the chassis,

MLO-006853

## 9.10 Assembly Separation

6. Lift the printer off the alignment pins and set the printer down.

MLO-006854

## 9.11 Photoreceptor (Print) Drum

### 9.11 Photoreceptor (Print) Drum

Use the following procedure to remove and replace the photoreceptor (print) drum from the DEClaser 3200 printer:

1. Open the top cover of the printer.
2. Grasp the green tab and pull the print drum cartridge halfway out.
3. Firmly grasp and remove the print drum cartridge.
4. Immediately place the print drum cartridge in the protective bag to prevent damaging the surface of the light sensitive print drum. If the light proof bag is unavailable, put the print drum in a draw or some other dark area.

MLO-006855

## 9.12 Developer Unit

### 9.12 Developer Unit

Use the following procedure to remove and replace the developer unit from the DEClaser 3200 printer:

**Caution:** *The surface of the print drum is sensitive to light and can be damaged by prolonged exposure to light.*

1. Spread out newspapers on a work surface to prepare a place to set down the developer unit.
2. Open the top door of the printer.
3. Grasp the green C handle and pull the developer unit part way out of the top cover. Be careful to keep your hands clean while handling the developer unit or toner cartridge.
4. Using both hands, remove the developer unit.
5. If you are installing a new developer unit, see Section 9.12.1 for instructions.

MLO-006856

### 9.12.1 Installing a new developer unit

Use the following procedure to install a new developer unit into the DEClaser 3200 printer:

**Caution:** *The surface of the print drum is sensitive to light and can be damaged by prolonged exposure to light.*

1. Spread out newspapers on a work surface to prepare a place to set down the developer unit.
2. Remove and discard the old developer unit, as shown in Section 9.12.
3. Unpack the new developer unit from the shipping container and place it on the previously prepared work area.
4. Peel away the strip that covers the developer roller.
5. Install a toner cartridge, as shown in Section 9.13.
6. Install the new developer unit, as shown in Section 9.12.

MLO-006857

## 9.13 Toner Cartridges

### 9.13 Toner Cartridges

Use the following procedure to remove and replace toner cartridge from the DEClaser 3200 printer:

**Caution:** *The surface of the print drum is sensitive to light and can be damaged by prolonged exposure to light.*

*Always use the special vacuum cleaner shown in Table D-2 for cleaning up toner. The toner powder can pass through the bag or filter of a conventional vacuum cleaner and cause damage.*

*Be careful to keep your hands clean while handling the developer unit or toner cartridge.*

1. Peel away the protective strip.
2. Install the toner cartridge in the tracks in the development unit.
3. Slowly push the toner cartridge fully into the development unit.

MLO-006859

### 9.14 Video Control Board

Use the following procedure to remove and replace the video control board from the DEClaser 3200 printer:

**Caution:** *Use the standard antistatic equipment and procedures when you handle this sensitive electronic component.*

1. Remove the ac line cord.
2. Remove any serial or parallel cables.
3. Loosen the two captive thumbscrews ❶.
4. Pull out the video control board until it hits the first stop.
5. Remove the 4-pin plug ❷ that connects to J7 on the video control board.
6. Remove the 25-pin plug ❸ that connects to J2 on the video control board.

MLO-006860

## 9.14 Video Control Board

7. Lift, then pull the video control board over the stop.
8. Remove the video control board.
9. Transfer any installed options from the old to the new video control board. Refer to the following procedures for information:
  - Section 9.14.1, PostScript Description Language Option (PDL) Board
  - Section 9.14.2, Coprocessor SIM
  - Section 9.14.3, Expansion Memory (SIM)

**Note:** *Make sure the 1/2Mb SIM is in the correct socket. See Section 9.14.3 for assistance.*

10. When replacing the video control board, place the circuit board in the tracks ④.

If there is a four-switch switchpack on the video control board, make sure all four switches are set to the ON position.

**Caution:** *The video control board can be damaged if operated without the cooling fan. Always check the fan to see if it is working.*

MLO-006861

### 9.14.1 PostScript Description Language Option (PDL) Board

Use the following procedure to remove and replace the PostScript Description Language Option (PDL) board from the video control board of the DEClaser 3200 printer:

**Caution:** *Use the standard antistatic equipment and procedures when you handle this sensitive electronic component.*

1. Clear a work area and spread the antistatic mat.
2. Remove the video control board, as shown in Section 9.14.
3. Place the video control board on the antistatic mat.
4. Gently rock and pull up the PDL board until it separates from the pins and J16 socket.
5. Remove the PDL board.

MLO-006862

## 9.14 Video Control Board

### 9.14.2 Coprocessor SIM

The coprocessor and the five memory expansion boards are referred to as a single in-line modules or SIMs. Use the following procedure to remove and replace the optional coprocessor SIM from the video control board of the DEClaser 3200 printer:

**Caution:** *Use the standard antistatic equipment and procedures when you handle this sensitive electronic component.*

1. Clear a work area and spread out the antistatic mat.
2. Remove the video control board, as shown in Section 9.14.
3. Place the video control board on the antistatic mat.
4. Remove any installed memory SIMs, as shown in Section 9.14.3.
5. Pinch backwards the two locking clips ❶. When the clips release, the SIM will pitch forward.
6. Lift and remove the coprocessor SIM.
7. To replace the coprocessor SIM, see the instructions on the next page.

MLO-006863

### Replacing the SIM

1. Pin-1 ② of the coprocessor SIM is toward the left edge of the video control board.
2. Insert the SIM at an angle, as shown below, visually lining up the two alignment pins.
3. Push the SIM up until it locks into position.

MLO-006864

## 9.14 Video Control Board

### 9.14.3 Expansion Memory (SIM)

#### About the Memory SIMs

The memory expansion and the coprocessor boards are referred to as single in-line modules or SIMs. A minimally configured DEClaser 3200 has a ½Mb memory SIM installed. By adding 2Mb SIMs, you can expand the memory up to 10Mb.

Figure 9–1 shows the 2Mb ❶ and the ½Mb ❷ SIM boards and Figure 9–2 shows the location of the sockets on the video control board.

When the 1502–1503 (see Section 5.25) error codes refers to a memory board, use Table 9–1 and Figure 9–2 to find the its physical location.

**Table 9–1 Memory SIM and Socket Allocation**

1502–1503 Display	Socket Number
❶ REPLACE MEM BD 1	J15
❷ REPLACE MEM BD 2	J14
❸ REPLACE MEM BD 3	J13
❹ REPLACE MEM BD 4	J12
❺ REPLACE MEM BD 5	J11

The ½Mb SIM must always be installed in the last available memory socket of the video control board. The following two examples show how to load the sockets for a standard ½Mb configuration and for an expanded 6½Mb configuration:

J15 ½Mb                      This example shows the minimum SIM configuration.  
J14 Empty  
J13 Empty  
J12 Empty  
J11 Empty

J15 2Mb                      This example shows the allocation for three 2Mb boards. The ½Mb  
J14 2Mb                      board is installed at the end of the stack. This configuration is  
J13 2Mb                      standard if the PDL option is installed.  
J12 ½Mb  
J11 Empty

**Figure 9–1 Memory SIMs**

MLO-00, Comments = Need a photo that shown both SIMs

**Figure 9–2 Memory SIM location**

MLO-006865

## 9.14 Video Control Board

Use the following procedure to remove and replace the memory SIMs from the video control board of the DEClaser 3200 printer:

**Caution:** *Use the standard antistatic equipment and procedures when you handle this sensitive electronic component.*

1. Clear a work area and spread out the antistatic mat.
2. Remove the video control board, as shown in Section 9.14.
3. Place the video control board on the antistatic mat.
4. Refer to Table 9–1 and Figure 9–2 to find physical location of a SIM.
5. To remove the memory SIM, pinch back the two locking clips. The SIM will spring forward when the clips release.
6. Lift and remove the SIM.
7. To replace a SIM, see the instructions on the next page.

MLO-006866

## 9.14 Video Control Board

### Replacing a memory SIM

- Pin-1 of the SIM goes toward the left edge of the video control board.
- Insert the SIM at the angle shown, visually lining up the two alignment pins.
- Push the SIM up until it locks into position.

MLO-006867

## 9.15 DC Control Board

### 9.15 DC Control Board

Use the following procedure to remove and replace the DC control board of the DEClaser 3200 printer:

1. Remove the following parts:
  - a. Top door cover, as shown in Section 9.2
  - b. Upper cover, as shown in Section 9.3
  - c. Rear panel, as shown in Section 9.4
2. Disconnect the 8-pin plug that connects to P41 on the DC control board.
3. Use a suitable tool to pinch the stake clips and free the restraint from the panel.
4. Remove the four screws that hold the side panel to the chassis and remove the side panel.

MLO-006868

## 9.15 DC Control Board

5. Open the top door.
6. Disconnect the 8-pin connector that connects the registration clutch and sensor to P38 on the back of the DC control board.

MLO-006869

## 9.15 DC Control Board

7. Disconnect all the following connectors from the DC control board:
  - ① 12-pin, P14 on the LVPSA
  - ② 8-pin, P35
  - ③ 6-pin, P32
  - ④ 16-pin, cable harness connector
  - ⑤ 26-pin, P37
  - ⑥ 20-pin, P36
  - ⑦ 32-pin, P30
  - ⑧ 19-pin, P47
8. Remove the screw that holds the control board to the chassis.
9. Pull the control board straight backwards until you feel the 10-pin plug disconnect from the developer interconnection board.

MLO-006870

## 9.15 DC Control Board

10. Remove the DC control board.
11. Swap the page count memory from the old to the new DC control board, as shown in Section 9.15.2.

MLO-006871

## 9.15 DC Control Board

### 9.15.1 DC Control Board Harness

Before you unplug any connectors from the DC control board harness, mark them for reconnection. The connectors are color coded to assist in reconnection, but should you inadvertently transpose some connections, use Table 9–2.

**Table 9–2 DC Control Board Harness**

<b>P/J #</b>		<b>Color</b>	<b>Device</b>
39	2-pin	Red/red	Upper feed solenoid
40	2-pin	Black	Lower feed solenoid
43	4-pin	Brown	Lower size-sensing and tray empty
33	3-pin	Red	Upper size-sensing and tray empty
45	2-pin	Brown	Lower turn roller clutch

MLO-006872

### 9.15.2 Page Count Memory

Use the following procedure to remove and replace the page count memory from the DC control board of the DEClaser 3200 printer:

**Caution:** *Use the standard antistatic equipment and procedures when you handle this sensitive electronic component.*

1. Remove the DC control board, as shown in Section 9.15.
2. Place the DC control board on the antistatic mat.
3. Use a suitable tool, a small screwdriver, to pry up each end of the page count memory.
4. Remove the page count memory from the U12 socket.

**Caution:** *Make sure to install pin-1 of the memory in pin-1 ❶ of the U12 socket. Pin-1 of the memory is marked by a dot.*

MLO-006873

## 9.16 LVPSA

### 9.16 LVPSA

Use the following procedure to remove and replace the LVPSA from the DEClaser 3200 printer:

1. Remove the following parts:
  - a. Top door cover, as shown in Section 9.2
  - b. Upper cover, as shown in Section 9.3
  - c. Rear panel, as shown in Section 9.4
2. Open the top cover.
3. Disconnect the 2-pin plug that connects the fusing unit to P10 on the LVPSA.

MLO-006874

4. Remove the two screws that hold the side of the LVPSA.

MLO-006875

## 9.16 LVPSA

5. Disconnect the following connectors:
  - ❶ 12-pin, P14
  - ❷ 2-pin, P52
  - ❸ 2-pin, P18 (P18 and P19 connectors are interchangeable)
  - ❹ 2-pin, P19
6. Remove the screw that holds the ring connector of the green ground (earth) wire.
7. Remove the two screws that hold the LVPSA to the back of the printer.
8. Remove the LVPSA.

MLO-006876

## 9.17 HVPSA

Use the following procedure to remove and replace the HVPSA from the DEClaser 3200 printer:

1. Remove the following parts:
  - a. Upper cover, as shown in Section 9.3
  - b. Rear panel, as shown in Section 9.4
  - c. LVPSA, as shown in Section 9.16
  - d. Transfer/separation charger, as shown in Section 9.25
  - e. Prefuser transport, as shown in Section 9.29.
  - f. DC control board, as shown in Section 9.15
2. Open the top cover.
3. Remove the two screws that hold the transfer connector block to the floor of the printer.
4. Remove the connector block wires.

MLO-006877

## 9.17 HVPSA

5. Remove the tab that holds the HVPSA to the chassis.
6. Remove the HVPSA.

MLO-006878

### 9.17.1 Primary High-Voltage Connector

Use the following procedure to remove and replace the connector that connects the primary charge wire in the print drum cartridge to the HVPSA terminal:

1. Remove the top door cover, as shown in Section 9.2
2. Remove the screw that holds the connector to the plastic bulkhead.
3. Remove the connector.

MLO-006979, Comment = Talent is removing screw and connector.

## 9.17 HVPSA

### 9.17.2 Print Drum Ground Clips

**Note:** *Whenever you replace the fusing unit, inspect the print drum ground clips. The ground clips wear out over time and must be replaced with the fuser unit at approximately 300,000 prints.*

Use the following procedure to remove and replace the clip assembly that connects the print drum axle to the metal chassis ground:

1. Open the top cover.
2. Remove the screw that holds the clips to the plastic bulkhead.
3. Remove the clip assembly.

MLO-006980

### 9.17.3 Developer Bias Connector

Use the following procedure to remove and replace the connector that connects the developer roller to the HVPSA terminal:

1. Remove the top door and upper covers, as shown in Section 9.2 and Section 9.3.
2. Remove the screw that holds the connector to the plastic bulkhead.

MLO-006981

## 9.18 Drive Board

### 9.18 Drive Board

Use the following procedure to remove and replace the drive board from the DEClaser 3200 printer:

**Caution:** *Use the standard antistatic equipment and procedures when you handle this sensitive electronic component.*

1. Remove the following parts:
  - a. Top door cover, as shown in Section 9.2
  - b. Upper cover, as shown in Section 9.3
  - c. Rear panel, as shown in Section 9.4
  - d. Transfer/separation charger, as shown in Section 9.25
  - e. Rear electronics assembly, as shown in Section 9.19
2. Disconnect all connectors from the driver board.
3. Remove the two screws that hold the driver board to the chassis and remove the driver board.

MLO-006879

### 9.19 Rear Electronics Assembly

Use the following procedure to remove and replace the rear electronics assembly from the DEClaser 3200 printer:

1. Remove the following parts:
  - a. Top door cover, as shown in Section 9.2
  - b. Upper cover, as shown in Section 9.3
  - c. Rear panel, as shown in Section 9.4
  - d. Prefuser transport, as shown in Section 9.29.
  - e. Transfer/separation charger, as shown in Section 9.25
2. Open the top cover.
3. Remove the two screws that hold the transfer connector block to the floor of the printer.
4. Disconnect the 2-pin plug ❶ that connects the fusing unit to P10 on the LVPSA.

MLO-006880

## 9.19 Rear Electronics Assembly

5. Disconnect the following:

- ① 2-pin, P52 on the LVPSA
- ② 2-pin, P18 on the LVPSA (P18 and P19 connectors are interchangeable)
- ③ 2-pin, P19 on the LVPSA
- ④ 8-pin, P35 that connects the DC control board to the main motor.
- ⑤ 16-pin connector that connects the DC control board wire harness.
- ⑥ 26-pin, P37, video control board connector.
- ⑦ 20-pin, P36 that connects the DC control board to the top door.

MLO-006881

## 9.19 Rear Electronics Assembly

6. Disconnect the 20-pin plug ⑦ that connects to P56 on the driver board.
7. Remove the two screws that hold the rear electronics assembly to the exit end of the printer.

MLO-006882

## 9.19 Rear Electronics Assembly

8. Remove the screw that holds the top of the rear electronics assembly to the printer.
9. Remove the screw that holds the bottom of the rear electronics assembly to the printer.

MLO-006883

## 9.19 Rear Electronics Assembly

10. Taking care not to damage any wires, remove the rear electronics assembly.  
When you replace the rear electronics assembly, carefully align the 10-pin connectors ⑧ of the developer interconnect board and P34 of the DC control board.

MLO-006884

## 9.20 Video Cooling Fan

### 9.20 Video Cooling Fan

Use the following procedure to remove and replace the fan that cools the video control board:

1. Remove the screw that holds the bottom cover to the bulkhead.
2. Remove the bottom cover.

MLO-006885

## 9.20 Video Cooling Fan

3. Remove the two screws that hold the fan mounting plate to the bulkhead.
4. Unplug the 3-pin connector from the fan.
5. Remove the fan assembly.

**Caution:** *The video control board can be damaged if operated without the cooling fan. Always check the fan to see if it is working.*

MLO-006886

## 9.21 Developer Interconnect Board

### 9.21 Developer Interconnect Board

Use the following procedure to remove and replace the developer interconnect board from the DEClaser 3200 printer:

1. Remove the following parts:
  - a. Print drum, as shown in Section 9.11
  - b. Developer Unit, as shown in Section 9.12.
2. Disconnect the 3-pin ❶ plug from the J71 connector on the interconnect board.
3. Remove the two screws that hold the interconnect board to the top door.
4. Unplug the interconnect board from the DC control board ❷ and remove the interconnect board.

MLO-006887

### 9.22 Upper Bracket

Use the following procedure to remove and replace the upper bracket from the DEClaser 3200 printer:

1. Remove the following parts:
  - a. Top door cover, as shown in Section 9.2
  - b. Upper cover, as shown in Section 9.3

**Caution:** *Use the standard antistatic equipment and procedures when you handle this sensitive electronic component.*
2. Disconnect the 28-pin plug ❶ (P/J 65) that connects to the control panel.
3. Remove the cable from the molded cable restraints ❷.
4. Remove the three screws that hold the front of the control panel to the chassis.

MLO-006888

## 9.22 Upper Bracket

5. Remove the two screws that hold the control panel bracket to the chassis.
6. Remove the control panel bracket.
7. Place the bracket on a desk or table.

MLO-006889

### 9.22.1 Fuser Fan

Use the following procedure to remove and replace the fuser fan from the DEClaser 3200 printer:

1. Remove the following parts:
  - a. Top door cover, as shown in Section 9.2
  - b. Upper cover, as shown in Section 9.3
  - c. Upper bracket, as shown in Section 9.22
2. Disconnect the 2-pin plug (P/J 66) from the control panel.
3. Remove the two  $1 \frac{3}{4}$  inch (44 mm) screws that hold the fan to the bracket and remove the fan.

MLO-006890

## 9.22 Upper Bracket

### 9.22.2 Control Panel

Use the following procedure to remove and replace the control panel from the DEClaser 3200 printer:

**Caution:** *Use the standard antistatic equipment and procedures when you handle this sensitive electronic component.*

1. Remove the following parts:
  - a. Top door cover, as shown in Section 9.2
  - b. Upper cover, as shown in Section 9.3
  - c. Upper bracket, as shown in Section 9.22
2. Disconnect the 2-pin plug that connects the fan to the control panel (not shown below).
3. Remove the four screws that hold the control panel to the bracket.
4. When you replace the control panel, do not forget to install the clear plastic sheet that insulates the back of the control panel from the metal bracket.

MLO-006891

### 9.23 Laser/Scanner Assembly

**Note:** *The laser scanner assembly is also referred to as the ROS assembly.*

Use the following procedure to remove and replace the laser scanner assembly from the DEClaser 3200 printer:

**Warning:** *Do not disassemble the laser scanner assembly in the field. Operation of a disassembled laser scanner assembly can expose yourself and other personnel in the room to the laser light. Inside the scanner assembly is a class 1b laser diode. Power output is 10 mW of 760–800 nm laser light. Light at this wavelength light is invisible to the naked eye.*

1. Remove the following parts:
  - Print drum, as shown in Section 9.11
  - Top door cover, as shown in Section 9.2
2. Insert the blade of a screwdriver under the tongue of the plastic wire clamp. Be careful not to separate the adhesive backing of the clamp.
3. Push and lift the tongue to open the clamp.

MLO-006892

## 9.23 Laser/Scanner Assembly

4. Unplug the 12-pin ❶ (P/J 60) connector from the scanner assembly.
5. Remove the three screws that hold the scanner assembly to the plastic chassis of the top door.

MLO-006893

## 9.23 Laser/Scanner Assembly

6. When you remove and handle the scanner assembly, be careful not to touch the glass window ② on the underside of the scanner assembly. Fingerprints or dirt can cause image defects.
7. Lift and remove the laser scanner assembly.

MLO-006894

## 9.24 Top Door (Scanner) Interlock Sensor

### 9.24 Top Door (Scanner) Interlock Sensor

Use the following procedure to remove and replace the top door (scanner) interlock sensor from the DEClaser 3200 printer:

1. Remove the following parts:
  - a. Top door cover, as shown in Section 9.2
  - b. Upper cover, as shown in Section 9.3
2. Disconnect the 2-pin plug that connects to the sensor.
3. Remove the screw that holds the sensor to the plastic of the top cover.
4. Remove the top door scanner interlock sensor.

MLO-006895

### 9.25 Transfer/Separation Charger

Use the following procedure to remove and replace the transfer/separation charge assembly from the DEClaser 3200 printer:

1. Carefully unsnap the transfer/separation assembly from the plastic catches.
2. Remove the transfer/separation assembly.

**Note:** *Thoroughly clean the transfer/separation charger, as shown in Section 10.6, before you replace it.*

MLO-006896

## 9.26 Erase Board

### 9.26 Erase Board

Use the following procedure to remove and replace the erase board from the top door of the DEClaser 3200 printer:

1. Remove the following parts:
  - a. Print drum, as shown in Section 9.11
  - b. Developer unit, as shown in Section 9.12.
  - c. Top door cover, as shown in Section 9.2
2. Close and latch the top cover.
3. Remove the screw that holds the two ring connectors to the ground plane.
4. Undo the catch ❶ and unplug the 6-pin connector.

MLO-006897

## 9.26 Erase Board

5. Open the top cover.
6. Pull the 6-wire cable and the green ground wire (earth) through the plastic bulkhead.
7. Remove the two screws that hold the erase board to the top cover and remove the erase board.

MLO-006898

## 9.27 Registration Transport Assembly

### 9.27 Registration Transport Assembly

**Note:** A black conductive grease is used on the registration transport assembly. No additional lubrication is necessary.

*Have a clean cloth available to wipe off any grease spots. Be careful when handling the transport assembly. After handling the transport assembly, check your hands for grease spots.*

Use the following procedure to remove and replace the registration transport assembly from the DEClaser 3200 printer:

1. Open the top cover. If the cover will be open for longer than three minutes, remove and store the print drum, as shown in Section 9.11.
2. Remove the following parts:
  - a. Transfer/separation charger, as shown in Section 9.25
  - b. Developer unit, as shown in Section 9.12.
3. Disconnect the 8-pin plug that connects through the metal chassis to the DC control board.
4. Remove the two screws that hold the registration transport to the bottom of the printer.

MLO-006899

## 9.27 Registration Transport Assembly

5. Lift and remove the registration transport assembly.

**Replacing the registration transport assembly** Before you install the transport assembly, make sure the clutch is fully on the shaft, and the clutch tab ❶ sits on the plastic post ❷.

After the transport assembly is mounted and before you screw it down, make sure it is fully seated.

MLO-006900

## 9.28 Fusing Unit

### 9.28 Fusing Unit

**Note:** *Whenever you replace the fusing unit, inspect the print drum ground clips. The ground clips wear out over time and must be replaced with the fuser unit at approximately 300,000 prints. See Section 9.17.2 for the removal and replacement procedure.*

Use the following procedure to remove and replace the fusing unit from the DEClaser 3200 printer:

1. Remove the following parts:
  - a. Print drum, as shown in Section 9.11
  - b. Top door cover, as shown in Section 9.2
  - c. Upper cover, as shown in Section 9.3
  - d. Postfuser transport, as shown in Section 9.30.
2. Remove the two screws that hold the gray baffle cover to the exit bulkhead and remove the cover.

**Caution:** *Do not disassemble the fusing unit.*

MLO-006901

## 9.28 Fusing Unit

3. Unplug the 2-pin connector ❶ from the LVPSA.
4. Unplug the 2-pin connector ❷ from the cable harness.
5. Loosen the four captive screws that hold the fusing unit to the floor of the printer.

MLO-00696982

## 9.28 Fusing Unit

6. Remove the fusing unit.

MLO-006904

### 9.28.1 Fuser Cleaning Pad

Use the following procedure to remove and replace the fuser cleaning pad from the DEClaser 3200 printer:

1. Turn off the printer power.
2. Open the exit side door.

**Caution:** *The fuser unit and cleaning pad are hot enough to cause minor skin burns. Be careful when handling fuser parts.*

3. Grasp the green handle and pull out the fuser cleaning pad. When you install the fuser cleaning pad, make sure it is fully seated.

MLO-006984

## 9.29 Prefuser Transport

### 9.29 Prefuser Transport

Use the following procedure to remove and replace the prefuser transport from the DEClaser 3200 printer:

1. Open the top cover. If the cover will be open for longer than three minutes, remove and store the print drum, as shown in Section 9.11.
2. Remove the three screws that hold the prefuser transport to the floor of the printer. When replacing the transport, make sure to attach the green ground (earth) wire ❶.
3. Lift and remove the prefuser transport.

MLO-006906

### 9.30 Lower Postfuser Transport

See Section 9.30.1 if you only intend to remove the upper assembly.

Use the following procedure to remove and replace the postfuser transport from the DEClaser 3200 printer:

1. Remove all the covers and the gate sensor linkage, shown in Section 9.31.
2. Disconnect the 3-pin plug ❶ from the chassis mounted harness connector.
3. Remove the two screws that hold the transport to the chassis.
4. Remove the postfuser transport.

MLO-006908

## 9.30 Lower Postfuser Transport

### 9.30.1 Upper Postfuser Transport Assembly

See Section 9.30 if you intend to remove and replace both upper and lower assemblies of the postfuser transport.

Use the following procedure to remove and replace the upper assembly of the postfuser transport from the DEClaser 3200 printer:

1. Open the exit side door.
2. Lift the upper assembly fully up.
3. Remove the rear (left) hinge pin.
4. Swing the rear side of the upper assembly out and remove the upper assembly.

MLO-00 Need two shots. One shows thumb holding up the assembly. Need to see hinge pins and detail.

### 9.31 Gate Sensor Linkage

Use the following procedure to remove and replace the gate sensor linkage from the DEClaser 3200 printer:

1. Remove the following parts:
  - a. Top door cover, as shown in Section 9.2
  - b. Upper cover, as shown in Section 9.3
2. Remove the linkage that actuates the gate sensor. Be careful not to bend the linkage.

MLO-006907

## 9.32 Refeed Cover

### 9.32 Refeed Cover

Use the following procedure to remove and replace the refeed cover from the DEClaser 3200 printer:

1. Remove the following parts:
  - a. Top door cover, as shown in Section 9.2
  - b. Upper cover, as shown in Section 9.3
  - c. Exit door, as shown in Section 9.8
2. Remove the two screws that hold the refeed cover to the chassis.
3. Remove the refeed cover.

MLO-006909

## 9.33 Refeed Rollers and Clutch

### 9.33 Refeed Rollers and Clutch

Use the following procedure to remove and replace the refeed roller, clutch, and the refeed pinch roller from the DEClaser 3200 printer:

1. Remove the following parts:
  - a. Top door cover, as shown in Section 9.2
  - b. Upper cover, as shown in Section 9.3
  - c. Rear panel, as shown in Section 9.4
  - d. Transfer/separation charger, as shown in Section 9.25
  - e. Rear electronics assembly, as shown in Section 9.19
  - f. Postfuser transport, as shown in Section 9.30
  - g. Refeed cover, as shown in Section 9.32
2. Remove the E-ring ❶ from the shaft and remove the idler gear.
3. Unplug the 2-pin connector that connects the refeed roller clutch to P53 of the drive board. The plug and connector are not shown.
4. Use a large needlenose pliers to unclip and remove the springs from each end of the refeed pinch roller.  
The front ❷ and rear ❸ springs are different.

### 9.33 Refeed Rollers and Clutch

MLO-006910

MLO-006911

### 9.33 Refeed Rollers and Clutch

5. Remove the E-rings ④ and bushing from the front and the rear of the refeed roller shaft.

MLO-006913

### 9.33 Refeed Rollers and Clutch

6. Move the refeed roller shaft fully forward.
7. Remove the refeed roller shaft and clutch.

MLO-006914

### 9.33 Refeed Rollers and Clutch

8. Loosen the set screw until you can push the refeed rolled shaft out of the clutch. The set screw goes completely through the shaft.

When replacing the shaft, place the tab of the refeed clutch ⑤ on the protruding metal stud. This prevents rotation of the clutch as the shaft turns.

MLO-006915

### 9.33 Refeed Rollers and Clutch

9. Remove the pinch roller.

MLO-006916

## 9.34 Exit Motor

### 9.34 Exit Motor

Use the following procedure to remove and replace the exit motor from the DEClaser 3200 printer:

1. Remove the following parts:
  - a. Top door cover, as shown in Section 9.2
  - b. Upper cover, as shown in Section 9.3
  - c. Upper bracket, as shown in Section 9.22
2. Disconnect the 6-pin plug ❶ that connects the exit motor to J54 on the driver board.
3. Remove the two screws that hold the exit motor to the chassis.
4. Remove the exit motor.

MLO-006917

### 9.35 Offset Motor Assembly

Use the following procedure to remove and replace the offset motor assembly from the DEClaser 3200 printer:

1. Remove the following parts:
  - a. Top door cover, as shown in Section 9.2
  - b. Upper cover, as shown in Section 9.3
  - c. Postfuser transport, as shown in Section 9.30
2. Disconnect the 4-pin plug ❶ that connects the offset motor to the wire harness.

MLO-006918

### 9.35 Offset Motor Assembly

3. Remove the coil spring ②.
4. Use a small screwdriver to remove the two screws that hold the offset arm block on to the offset assembly.

MLO-006919

### 9.35 Offset Motor Assembly

5. Remove the two screws that hold the offset motor assembly to the chassis.
6. Remove the offset motor assembly.

MLO-006920

## 9.36 Main Motor

### 9.36 Main Motor

Use the following procedure to remove and replace the main motor from the DEClaser 3200 printer:

1. Remove the following parts:
  - a. Top door cover, as shown in Section 9.2
  - b. Upper cover, as shown in Section 9.3
  - c. Rear panel, as shown in Section 9.4
  - d. Transfer/separation charger, as shown in Section 9.25
  - e. Prefuser transport, as shown in Section 9.29.
  - f. Rear electronics assembly, as shown in Section 9.19
2. Gently pull and unsnap the rear gear from the end of the drive shaft.
3. Remove the gear.

MLO-006921

## 9.36 Main Motor

4. Disconnect the spring ❶ that pulls open the exit drive gear.
5. Remove the five screws that hold the main motor assembly to the printer chassis.

When replacing this screw ❷, make sure to install the green ground (earth) wire.

MLO-006922

### 9.36 Main Motor

6. Carefully withdraw the main motor assembly. The tight-fitting latch pin ③ can easily bind, making the removal task difficult.

**Caution:** *Gears and bushings can drop off the main motor assembly. Do not invert the assembly. Watch for falling parts.*

When replacing the motor assembly, first install the bushing ④ for the prefuser transport in the bulkhead.

MLO-006923, MLO-006924

### 9.37 Upper Cassette-empty Sensor

Use the following procedure to remove and replace the upper cassette empty sensor from the DEClaser 3200 printer:

1. Remove the following parts:
  - a. Print drum, as shown in Section 9.11
  - b. Registration transport assembly, as shown in Section 9.27.
2. Open the feed door.
3. Unplug the 3-pin ❶ connector (P/J 70) from the sensor.
4. Unsnap the restraining clips and remove the sensor.

**Caution:** *The restraining clips can be easily damaged.*

MLO-006925

## 9.38 Upper Size-sensing Assembly

### 9.38 Upper Size-sensing Assembly

Use the following procedure to remove and replace the upper size-sensing assembly from the DEClaser 3200 printer:

1. Remove the following parts:
  - a. Top door and upper covers, as shown in Section 9.2 and Section 9.3
  - b. Transfer/separation charger, as shown in Section 9.25
  - c. Upper feed roller and clutch, as shown in Section 9.50
  - d. Rear panel and rear electronics assembly, as shown in Section 9.4 and Section 9.19
  - e. Upper feed solenoid, as shown in Section 9.51
2. Disconnect the 3-pin connector ❶ from the upper cassette-empty sensor.
3. Remove the 3-wire ❷ cable from the clips.

**Caution:** *The restraining clips can be easily damaged.*

*Before you unplug any connectors from the DC control board harness, mark them for reconnection. Should you inadvertently transpose some connections, see Table 9-2 in Section 9.15.*

MLO-006926

### 9.38 Upper Size-sensing Assembly

4. Gently push the sensor assembly sideways to unsnap the three restraints **③** that hold the sensor assembly to the bulkhead.
5. Pull the sensor cable out from underneath the chassis.

MLO-006927

## 9.39 Lower Cassette-empty Sensor

### 9.39 Lower Cassette-empty Sensor

Use the following procedure to remove and replace the lower cassette-empty sensor from the DEClaser 3200 printer:

1. Remove the following parts:
  - a. Top door cover, as shown in Section 9.2
  - b. Upper cover, as shown in Section 9.3
  - c. Rear panel, as shown in Section 9.4
  - d. Rear electronics assembly, as shown in Section 9.19
  - e. Remove the printer from the lower cassette assembly, as shown in Section 9.10.
2. Disconnect the 3-pin plug (P/J 72) that connects to the sensor assembly.
3. Unsnap the restraining clips and remove the sensor.

**Caution:** *The restraining clips can be easily damaged.*

MLO-006928

### 9.40 Lower Size-sensing Assembly

Use the following procedure to remove and replace the lower size-sensing assembly from the DEClaser 3200 printer:

1. Remove the following parts:
  - a. Top door and upper covers, as shown in Section 9.2 and Section 9.3.
  - b. Rear panel and rear electronics assembly, as shown in Section 9.4 and Section 9.19
  - c. Remove the printer from the lower cassette assembly, as shown in Section 9.10.
  - d. Lower turn roller and clutch, as shown in Section 9.53
  - e. Lower feed roller and clutch, as shown in Section 9.52

**Caution:** *The restraining clips can be easily damaged.*

2. Gently push the sensor assembly sideways to unsnap the three restraints ❶ that hold the sensor assembly to the bulkhead.
3. Unplug the 4-pin connector from the DC control board harness.
4. Pull the sensor cable out from underneath the chassis.

MLO-006929

## 9.41 Bypass Sensor

### 9.41 Bypass Sensor

Use the following procedure to remove and replace the bypass sensor from the DEClaser 3200 printer:

1. Remove the following parts:
  - a. Print drum as shown in Section 9.11
  - b. Top door cover, as shown in Section 9.2
  - c. Upper cover, as shown in Section 9.3
2. Open the feed door.
3. Unplug the 3-pin connector ❶ from the sensor.
4. Unsnap the restraining clips ❷ and remove the sensor.

**Caution:** *The restraining clips can be easily damaged.*

MLO-006930

### 9.42 Exit Sensor

Use the following procedure to remove and replace the exit sensor from the DEClaser 3200 printer:

1. Remove the following parts:
  - a. Top door cover, as shown in Section 9.2
  - b. Upper cover, as shown in Section 9.3
2. Remove the screw that holds the sensor assembly to the exit chassis.
3. Unplug the sensor assembly ❶ from the 3-pin harness connector.
4. Remove the sensor assembly.

MLO-006931

## 9.43 Refeed Sensor

### 9.43 Refeed Sensor

Use the following procedure to remove and replace the refeed sensor from the DEClaser 3200 printer:

1. Remove the following parts:
  - a. Top door cover, as shown in Section 9.2
  - b. Upper cover, as shown in Section 9.3
  - c. Postfuser transport, as shown in Section 9.30
2. Position the postfuser transport upside down and shown below.
3. Remove the three screws that hold the refeed baffle to the transport assembly.
4. Remove the refeed baffle. When replacing the baffle, make sure the refeed sensor cable ❶ runs under the baffle pin.

MLO-006932

## 9.43 Refeed Sensor

5. Unsnap the restraining clips, and remove the sensor.

**Caution:** *The restraining clips can be easily damaged.*

MLO-006933

## 9.44 Feed-Door Sensor

### 9.44 Feed-Door Sensor

Use the following procedure to remove and replace the feed door sensor from the DEClaser 3200 printer:

1. If the printer is equipped with an LCIT, lift the LCIT up and off the alignment pins and swing it aside.
2. Open the feed door
3. Remove the screw that holds the sensor to the chassis.
4. Unplug the 2-pin connector ❶ from the sensor.
5. Remove the sensor.

MLO-006934

### 9.45 Exit-Door Sensor

Use the following procedure to remove and replace the exit-door sensor from the DEClaser 3200 printer:

1. Remove the following parts:
  - a. Top door cover, as shown in Section 9.2
  - b. Upper cover, as shown in Section 9.3
2. Remove the screw holding the sensor to the chassis.
3. Remove the sensor from its bulkhead mounting pin.
4. Unplug the 2-pin connector that connects the exit-door sensor to P57 of the driver board.

MLO-006935

## 9.46 Registration Sensor

### 9.46 Registration Sensor

Use the following procedure to remove and replace the registration sensor from the DEClaser 3200 printer:

1. Open the top cover. If the cover will be open for longer than three minutes, remove and store the print drum, as shown in Section 9.11.
2. Remove the following parts:
  - a. Transfer/separation charger, as shown in Section 9.25
  - b. Developer unit, as shown in Section 9.12.
3. Remove the registration transport assembly, as shown in Section 9.27.
4. Position the transport assembly upside down on a work surface.
5. Unplug the 3-pin connector (P/J 76) from the sensor.
6. Unsnap the restraining clips and remove the registration sensor. Use a screwdriver to gently work loose the four plastic clips.

**Caution:** *The restraining clips can be easily damaged.*

MLO-006936

### 9.47 Tray-full Sensor

Use the following procedure to remove and replace the tray-full sensor from the DEClaser 3200 printer:

1. Remove the following parts:
  - a. Top door cover, as shown in Section 9.2
  - b. Upper cover, as shown in Section 9.3
  - c. Upper bracket, as shown in Section 9.22
2. Disconnect the 3-pin ❶ plug from J59 on the driver board.  
**Caution:** *The restraining clips can be easily damaged.*
3. Unsnap the restraining clips and remove the tray-full sensor.

MLO-006937

## 9.48 Exit Pinch Roller

### 9.48 Exit Pinch Roller

Use the following procedure to remove and replace the exit pinch rollers from the DEClaser 3200 printer:

1. Remove the following parts:
  - a. Top door cover, as shown in Section 9.2
  - b. Upper cover, as shown in Section 9.3
  - c. Upper bracket, as shown in Section 9.22
2. Disconnect the 3-pin plug that connects to the refeed sensor in the postfuser transport.
3. Undo the clips and poke the connector through the bulkhead hole.

MLO-006985

## 9.48 Exit Pinch Roller

4. Unplug the offset motor ❶ and fusing unit connectors ❷ from the wire harness.
5. Cut the plastic tie wrap.
6. Remove the two screws that hold the pinch roller assembly to the front of the bulkhead.

MLO-006986

## 9.48 Exit Pinch Roller

7. Cut the plastic tie wrap ③.
8. Release the cable harness from the three restraining clips ④.
9. Unplug the 3-pin connector ⑤ from the exit sensor.
10. Fold the wire harness clear of the exit assembly.

MLO-006987

## 9.48 Exit Pinch Roller

11. Remove the screw that holds the tray-full sensor bracket to the bulkhead.
12. Remove the bracket and allow it to hang on the 3-sensor wires.
13. Remove the two screws that hold the pinch roller assembly to the rear of the exit assembly.

MLO-006988

## 9.48 Exit Pinch Roller

14. Remove the exit pinch roller assembly.

MLO-006989

### 9.49 Exit Drive Roller

Use the following procedure to remove and replace the exit drive rollers from the DEClaser 3200 printer:

1. Remove the following parts:
  - a. Top door cover, as shown in Section 9.2
  - b. Upper cover, as shown in Section 9.3
  - c. Postfuser transport, as shown in Section 9.30
2. Remove the coil spring ❶.
3. Use a small screwdriver to remove the two screws that hold the offset arm block to the offset assembly.

MLO-006939

#### **9.49 Exit Drive Roller**

4. Remove the two screws that hold the fusing cover to the exit bulkhead.
5. Remove the fusing cover.

MLO-006940

## 9.49 Exit Drive Roller

6. Remove the E-ring from each end of the exit drive shaft.
7. Remove the bushing from each end of the exit drive shaft.
8. Remove the exit drive roller assembly.

MLO-006941

MLO-006942

## 9.50 Upper Feed Roller/Clutch

### 9.50 Upper Feed Roller/Clutch

Use the following procedure to remove and replace the upper feed roller assembly from the DEClaser 3200 printer:

1. Remove the following parts:
  - a. Print drum, as shown in Section 9.11
  - b. Top door cover, as shown in Section 9.2
  - c. Upper cover, as shown in Section 9.3
2. Remove the E-ring ❶ from the front end of the feed roller shaft.
3. Remove the plastic bushing ❷ from the front end of the feed roller shaft.

MLO-006943

## 9.50 Upper Feed Roller/Clutch

4. Open the feed door.
5. Press the inside bushing out of the chassis.

MLO-006944

## 9.50 Upper Feed Roller/Clutch

6. Lift and remove the upper feed roller assembly.
7. See next page for replacing information.

MLO-006945

## 9.50 Upper Feed Roller/Clutch

8. Always replace the feed roller assembly as a single FRU. If you are replacing the feed rollers, make sure of the following:
  - The feed rollers ③ are positioned over the outside shaft holes. The middle hole ④ remains empty.
  - Align the feed rollers and pins as shown below and not 180° off.

MLO-006946

## 9.51 Upper Feed Solenoid

### 9.51 Upper Feed Solenoid

Use the following procedure to remove and replace the upper feed solenoid from the DEClaser 3200 printer:

1. Remove the following parts:
  - a. Print drum, as shown in Section 9.11
  - b. Top door and Upper covers, as shown in Section 9.2 and Section 9.3.
  - c. Rear panel and Rear electronics assembly, as shown in Section 9.4 and Section 9.19
  - d. Transfer/separation charger, as shown in Section 9.25
  - e. Upper feed roller and clutch, as shown in Section 9.50

**Caution:** *Before you unplug any connectors from the DC control board harness, mark them for reconnection. Should you inadvertently transpose some connections, see Table 9-2, in Section 9.15.*

2. Remove the screw that holds the solenoid to the chassis.
3. Unplug the 2-pin connector from the DC control board harness.
4. Remove the solenoid.

MLO-006947

## 9.52 Lower Feed Roller/Clutch and Solenoid

### 9.52 Lower Feed Roller/Clutch and Solenoid

Use the following procedure to remove and replace the feed roller, clutch, and solenoid from the DEClaser 3200 printer:

1. Remove the following parts:
  - a. Top door and Upper covers, as shown in Section 9.2 and Section 9.3
  - b. Rear panel and Rear electronics assembly, as shown in Section 9.4 and Section 9.19
  - c. Remove the printer from the lower cassette assembly, as shown in Section 9.10.
  - d. Lower turn roller and clutch, as shown in Section 9.53
2. Lift and remove the feed roller and clutch assembly.
3. Always replace the feed roller assembly as a single FRU. If you are replacing the feed rollers, make sure of the following:
  - The feed rollers ① are positioned over the outside shaft holes. The middle hole ② remains empty.
  - Align the feed rollers and pins as shown below and not 180° off.

## 9.52 Lower Feed Roller/Clutch and Solenoid

MLO-006948

## 9.52 Lower Feed Roller/Clutch and Solenoid

4. Remove the screw that holds the solenoid and ring connectors of the green ground (earth) wires to the frame of the lower cassette assembly.
5. Remove the solenoid.

**Note:** *The spacer ③ was added to early printers to correct a slight timing problem. On later models the plastic boss ④ that the solenoid mounts on was altered. If this spacer is left off, expect an increase in the number of 0822 type jams.*

MLO-006949

MLO-00, Comment = Line art showing spacer and boss

### 9.53 Lower Turn Drive Roller and Clutch

Use the following procedure to remove and replace the lower turn roller and clutch assembly from the DEClaser 3200 printer:

1. Remove the following parts:
  - a. Top door and Upper covers, as shown in Section 9.2 and Section 9.3
  - b. Rear panel and Rear electronics assembly, as shown in Section 9.4 and Section 9.19
  - c. Remove the printer from the lower cassette assembly, as shown in Section 9.10.
2. Remove the screw that holds the ring connector of the green ground (earth) wire to the copper plate.

When you replace the lower turn roller, make sure the spring fingers ❶ ride on the shafts of the feed and turn rollers.
3. Remove the four screws that hold the turn roller assembly to the plastic frame.

MLO-006950

## 9.53 Lower Turn Drive Roller and Clutch

4. Remove the lower turn drive roller and clutch.

**Note:** *A black conductive grease is used on the registration transport assembly. No additional lubrication is necessary.*

*Have a clean cloth available to wipe off any grease spots. Be careful when handling the transport assembly. After handling the transport assembly, check you hands for grease spots.*

MLO-006951

---

## Adjustments and Cleaning Procedures

This chapter covers the DEClaser 3200 adjustments and cleaning procedures.

### 10.1 Setting Auto Scan

Scanner auto time is the time that the scanner remains on while a job is processing in the video control board. Use the following procedure to enter, change, and exit the Auto Scan menu:

1. Press and hold  and  while powering up the printer.
2. When you see four zeros (0000), press the menu mode keys to set the 1701 code and press  once to enter it, as shown in Table 3-1.
3. Press the menu mode keys to set the 0282 code and press  to enter it.
4. Press the menu mode keys to set the 0282.80 code.
5. Press  to enter the code. The current setting, or default, is displayed. The following example demonstrates Auto Scan menu:

**\$39 : 570 sec**

**\$** A dollar sign acts as a prompt.

**39** The two digit hexadecimal set code. The higher order digit (3) changes the the time by  $\pm 160$  second increments. The lower order digit (9) changes the time by  $\pm 10$  second increments.

**:** A colon separates the set code from the offset display.

**570 sec** The time display is the time in seconds, approximately 9.5 minutes. The recommended setting is \$01: 20

6. Press the menu mode keys to change the set code and alter the Auto Scan time display.
7. Press  to enter the Auto Scan time.
8. Press  and  to exit Auto Scan set menu. The four zeros (0000) will reappear.

## 10.1 Setting Auto Scan

9. Power the printer off, then on to return to online operation.

## 10.2 Setting Power Saver Time

The fuser power saver timer is adjustable between 0 and 7650 seconds in 30 second increments. If no printing is performed and the timer zeros out, the printer enters the Power Saver mode and displays the message POWER SAVER ON.

In the Power Saver mode, fuser power shuts off and fuser cools to room temperature. When a print job is received, the message POWER SAVER OFF is displayed for the minute or so of warm up time.

1. Press and hold  and  while powering up the printer.
2. When you see four zeros (0000), press the menu mode keys to set the 1701 code and press  once to enter it, as shown in Table 3-1.
3. Press the menu mode keys to set the 0282 code and press  to enter it.
4. Press the menu mode keys to set the 0282.90 code.
5. Press  to enter the code. The current setting, or default, is displayed. The following example demonstrates the power saver format:

**\$57 : 2730**

**\$** A dollar sign acts as a prompt.

**57** The two digit hexadecimal set code. The higher order digit (5) changes the time by  $\pm 480$  second increments from a start of 600. The lower order digit (7) changes the time by  $\pm 30$  second increments from a start of 150. When set to zero (00) the time is forced to 7680.

**:** A colon separates the set code from the offset display.

**2730** The time display is the time in seconds approximately 45.5 minutes. The recommended setting is \$FF: 7680 or 00 : 7680

6. Press the menu mode keys to change the set code and alter the power saver time display.
7. Press  to enter the new power saver time.
8. Press  and  to exit from the power saver time set menu. The four zeros (0000) will reappear.
9. Power the printer off, then on to return to online operation.

### 10.3 Horizontal Registration Adjustment

The horizontal registration fixes the image between the rear and front of the printer. The horizontal registration is perfect when the width of the the rear and front borders are identical. Use the following procedure to enter, change, and exit the Horizontal Registration set menu:

1. Press and hold Defaults and > while powering up the printer.
2. When you see four zeros (0000), press the menu mode keys to set the 1701 code and press \* once to enter it, as shown in Table 3–1.
3. Press the menu mode keys to set the 0282 code and press \* to enter it.
4. Press the menu mode keys to set 0282.01 code.
5. Press \* to enter the code. The current setting, or default, is displayed. The following example demonstrates the Horizontal Registration set menu format:

**\$05: →0.5mm**

**\$** A dollar sign acts as a prompt.

**05** This is the two digit hexadecimal set code. The higher order digit (0) is always zero and it cannot be altered. The lower order digit (5) changes the offset display by ±0.5mm increments per digit.

**:** A colon separates the set code from the offset display.

**→** The arrow indicates the direction of image offset from the center of the sheet. Left is towards the front of the printer, right is towards the rear of the printer.

**0.5mm** The amount of offset shift for the accompanying set code. The following settings are available:

\$00:←2.0mm	\$05:→0.5mm
\$01:←1.5mm	\$06:→1.0mm
\$02:←1.0mm	\$07:→1.5mm
\$03:←0.5mm	\$08:→2.0mm
\$04: 0:0mm Recommended factory default setting.	

6. Press ^ and v to change the lower order set code.
7. Press \* to enter the new position.
8. Press > and Defaults to exit from the Horizontal Registration set menu. The four zeros (0000) will reappear.
9. Power the printer off, then on to return to online operation.

## 10.4 Vertical Registration Adjustment

### 10.4 Vertical Registration Adjustment

The vertical registration fixes the image between the leading and trailing edges of the sheet. The vertical registration is perfect when the width of the leading and trailing borders are identical. Use the following procedure to enter, change, and exit the Vertical Registration set menu:

1. Press and hold **Defaults** and **>** while powering up the printer.
2. When you see four zeros (0000), press the menu mode keys to set the 1701 code and press **\*** once to enter it, as shown in Table 3–1.
3. Press the menu mode keys to set the 0282 code and press **\*** to enter it.
4. Press the menu mode keys to set 0282.02 code.
5. Press **\*** to enter the code. The current setting, or default, is displayed. The following example demonstrates the Vertical Registration set menu format:

#### **\$0A: ↓0.9mm**

**\$** A dollar sign acts as a prompt.

**0A** The two digit hexadecimal set code. The higher order digit (0) is always zero and it cannot be altered. The lower order digit (A) changes the offset display.

**:** A colon separates the set code from the offset display.

**↓** Arrows indicate the direction of image offset from the dead center of the sheet. Down is toward the trailing edge, up is toward the leading edge.

**0.9mm** The amount of offset shift for the accompanying set code. The following settings are available:

\$00:↑3.6mm	\$08: 0.0mm Recommended factory default.
\$01:↑3.2mm	\$09:↓0.5mm
\$02:↑2.7mm	\$0A:↓0.9mm
\$03:↑2.3mm	\$0B:↓1.4mm
\$04:↑1.8mm	\$0C:↓1.8mm
\$05:↑1.4mm	\$0D:↓2.3mm
\$06:↑0.9mm	\$0E:↓2.7mm
\$07:↑0.5mm	\$0F:↓3.2mm

6. Press **^** and **v** to change the lower order set code and change the image position.
7. Press **\*** to enter the new position.
8. Press **>** and **Defaults** to exit from the Vertical Registration set menu. The four zeros (0000) will reappear.

## 10.4 Vertical Registration Adjustment

9. Power the printer off, then on to return to online operation.

## 10.5 Feed Roller Cleaning Procedure

The DEClaser 3200 upper and lower paper feed rollers are designed to last for approximately 1 million prints, without periodic cleaning. Cleaning might be necessary if the customer uses excessively dusty stock or two sided preprinted forms.

Unless referred here by another FIP, use the following guidelines to determine when to clean the paper feed rollers:

- Every time the fusing unit is replaced after printing 300,000 pages.
- If you notice an increased number of 0821 or 0822 upper or lower cassette feed failures.
- If you notice increased skewing from the upper or lower cassettes.

A special tool and alcohol towelettes are available for cleaning the feed rollers, see Section D.2 for the part numbers. If the special tool is not available and the rollers need cleaning, you must disassemble the printer to access the feed roller, and clean it with an alcohol soaked towelette or replace the feed rollers, as shown in Section 9.50 and Section 9.52

Use the following procedure to clean the surface of the upper or lower feed roller with the special cleaning tool:

Step	Description or Note
1. Power down the printer	Remove any installed cartridges.
2. Power the printer on	After a short wait, the Online indicator will light and READY is displayed.
3. Press <input type="button" value="Online/Pause"/>	To extinguish the Online indicator and display PAUSED.
4. Press <input type="button" value="Set Up"/>	The PROTOCOL message is displayed.
5. Select DEC PPL3 protocol	As shown in Section 2.4.1
6. Select the upper or lower cassette slot	From the TRAY SELECTION submenu of the DEC PPL3 protocol feature. (See Section E.1.1, TRAY SELECTION for more information.)
7. Press <input type="button" value="Online/Pause"/> twice	To leave the Set Up menu and return to offline operation.

## 10.5 Feed Roller Cleaning Procedure

Step	Description or Note
8. Press <input type="button" value="Test"/>	Enter the Test menu. See Section 2.6 for additional information. CONFIG SHEET will appear on the display.
9. Remove the cassette from the selected slot.	Do the following: <ol style="list-style-type: none"><li>1. Remove the paper.</li><li>2. Install the cleaning tool in the cassette so the fur pad will contact the feed rollers.</li><li>3. Open two packages and remove the alcohol towelettes.</li><li>4. Wring the alcohol out of both towelettes onto both fur pads.</li></ol>
10. Insert the cassette and cleaning tool	Into the slot that was selected in step 6 above.
11. Press <input type="button" value="*"/>	To print the CONFIG SHEET. Depending on which slot was selected, in step 6 above, one of the following messages will appear: <ul style="list-style-type: none"><li>• CLEAR PAPER PATH 0821</li><li>• CLEAR PAPER PATH 0822</li></ul>
12. Remove the cassette and cleaning tool	From the selected slot.
13. Power down the printer	Repeat the procedure to clean the other feed rollers.

## 10.6 Transfer/Separation Charger Cleaning Procedure

### 10.6 Transfer/Separation Charger Cleaning Procedure

The transfer/separation charger should be replaced at 50,000 page intervals and cleaned at 20,000 page intervals.

Use the following procedure to clean the transfer/separation charger:

1. Remove the transfer/separation charger, as shown in Section 9.25.
2. Close the top cover to protect the photoreceptor drum.
3. Gently clean the charge wire with a cotton swab until no toner remains on the wire. Carefully move around the nylon wires that pass diagonally over it.
4. Hold the charger upright in the vertical position and clean the toner from the sawtooth comb with the cleaning brush.

## 10.6 Transfer/Separation Charger Cleaning Procedure

Figure 10–1 Cleaning the Transfer/Separation Charger

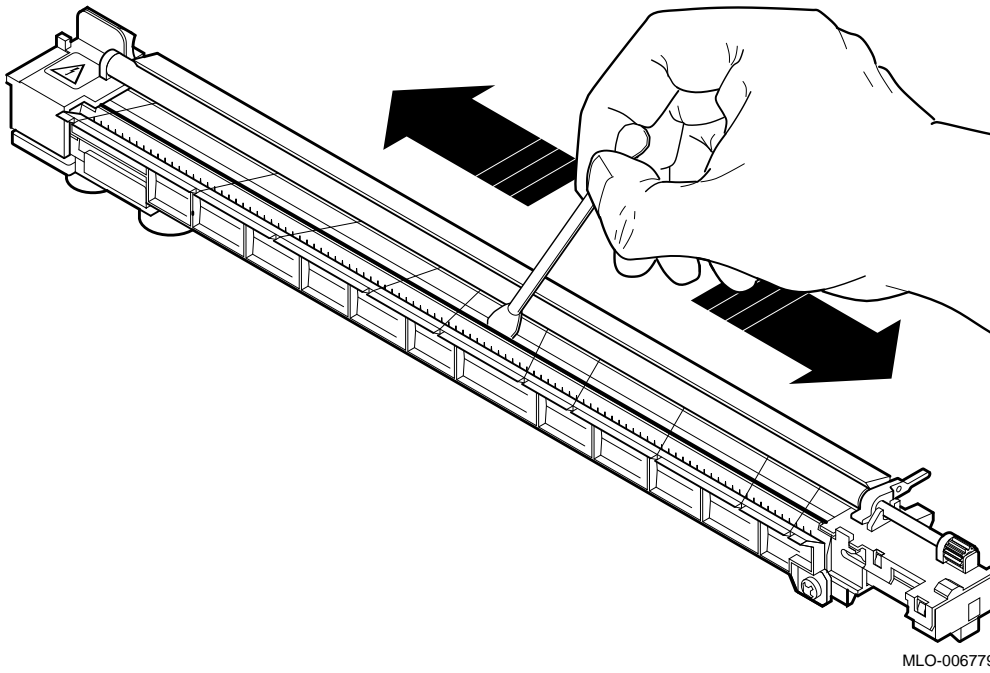

---

## Large Capacity Input Tray (LCIT)

This chapter is about the large-capacity input tray (LCIT) option for the DEClaser 3200 printer.

**Figure 11–1 DEClaser 3200 with LCIT**

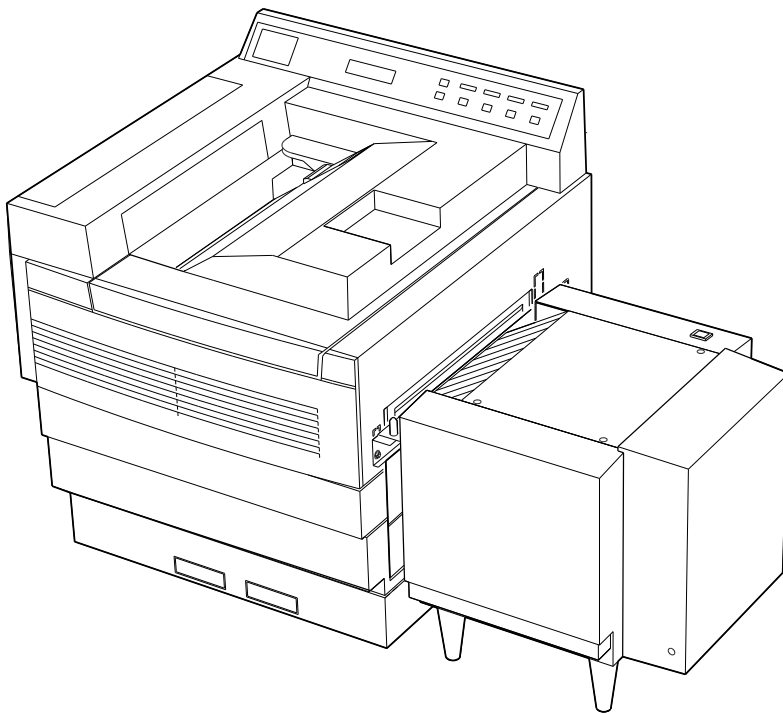

MLO-006975

## 11.1 LCIT Physical and Functional Description

### 11.1 LCIT Physical and Functional Description

Figure 11–2 presents a view of the rear of the LCIT that is connected to the DEClaser 3200 printer. To find the names and function of the items pointed to see Table 11–1.

**Figure 11–2 LCIT External View**

MLO-00\*.\*

## 11.1 LCIT Physical and Functional Description

**Table 11–1 LCIT External View**

<b>Component</b>	<b>Function</b>
① Front side cover	See Section 11.4.3 for the removal and replacement procedure.
② Printer mounting plate	This customer installed plate aligns the LCIT with the bypass slot. See Section 9.9 for the removal and replacement procedure.
③ LCIT to printer cable	Supplies DC power and a communication path between the DC and LCIT control boards.
④ Rear side cover	See Section 11.4.2 for the removal and replacement procedure.
⑤ Elevator switch	Press to lower the elevator.
⑥ Loading door	When opened, the elevator motion will stop. When closed, the elevator will raise to the upper limit.
⑦ Top Cover	The guides on the top cover direct the sheet into the entrance guides of the bypass slot. See Section 11.4.1 for the removal and replacement procedure.

## 11.1 LCIT Physical and Functional Description

Figure 11–3 presents an internal rear side view of the LCIT. To find the names and function of the items pointed to see Table 11–2.

### Figure 11–3 Internal Rear Side View

MLO-006952

## 11.1 LCIT Physical and Functional Description

**Table 11–2 Internal Rear Side View**

Component	Function
① Feed roller motor	Powers the drive shaft and chain to turn the roller shaft. See Section 11.4.5 for the removal and replacement procedure.
② Feed rollers	Turn to push a sheet into the bypass paper path. The rollers freewheel in the reverse direction, thus easing jam clearance. See Section 11.4.11 for the removal and replacement procedure.
③ Upper limit switch	When the elevator lifts the paper into the feed rollers, the upper limit actuates the switch, thus establishing the upper limit. See Section 11.4.9 for the removal and replacement procedure.
④ LCIT control board	Controls everything in the LCIT and communicates with the DC control board. See Section 11.4.6 for the removal and replacement procedure.
⑤ Lower limit switch	The elevator actuates this switch at the bottom of its descent. See Section 11.4.8 for the removal and replacement procedure.
⑥ Elevator belt clamp	Used for parallelism adjustment procedure, see Section 11.3 for instructions.
⑦ Door switch	Detects when the door is closed and stops elevator motion when the door is open. See Section 11.4.10 for the removal and replacement procedure.

## 11.1 LCIT Physical and Functional Description

Figure 11–4 presents an internal front side view of the LCIT. To find the names and function of the items pointed to see Table 11–3.

### Figure 11–4 Internal Front Side View

MLO-006953

## 11.1 LCIT Physical and Functional Description

Table 11–3 Internal Front Side View

Component	Function
❶ Paper-out switch	Detects the presence of paper in the LCIT and causes the elevator to descend. See Section 11.4.7 for the removal and replacement procedure.
❷ Elevator belt clamp	Used for parallelism adjustment procedure, see Section 11.3 for instructions.
❸ Elevator motor	Lifts or drops the elevator. See Section 11.4.4 for the removal and replacement procedure.

## 11.2 LCIT FIPs

**Description:** The LCIT has no troubleshooting aids, such as indicators, message display, or self-tests. To troubleshoot, you must observe the elevator operation and paper feeding. Use the instructions under Section 3.3, Test Print Menu, to continuously feed test patterns.

See Section 11.2.1 for information about the printer error codes that pertain to the LCIT.

**Troubleshooting:** Before attempting to fix the LCIT, power up the printer and print several test prints from a cassette. Fix any printer problems first.

Use the following procedure to verify the LCIT operation. If problems occur, find the symptom in the list below.

- At power up and when you open and close the door, the elevator will rise to the upper limit, if not there already.
- When you press the elevator key or hold down (with a pencil) the paper-out switch, the elevator will descend to the lower limit.

**Symptom:** The elevator fails to move up or down. The LCIT is completely dead.

1. Inspect all the connectors and associated wires shown in Figure 11–5. Make sure none are plugged in backwards and that they are in good condition.
2. Swap the following:
  - Printer’s DC control board
  - LCIT control board
  - Door switch

## 11.2 LCIT FIPs

- Lower limit switch
- Paper-out switch
- Elevator motor

**Symptom:** The elevator moves but fails to stop when door is opened, or fails to rise when the door is closed. The symptom indicates a door switch problem. Do the following:

1. Make sure the 2-pin plug that connects the door switch to P/J7 of the control board is plugged in and connected properly.
2. Swap the door switch or test it with an ohmmeter. The switch closes when the door is closed.
3. Swap the LCIT control board.

**Symptom:** The elevator descends but makes repetitive thumping sounds at lower limit. Symptom indicates a lower limit switch problem. Do the following:

1. Make sure the 2-pin plug that connects the lower limit switch to P/J4 on the control board is plugged in and connected properly.
2. Swap the lower limit switch or test it with an ohmmeter. The switch closes when the elevator is down.
3. Swap the control board.

**Symptom:** The elevator lifts but makes repetitive thumping sounds at upper limit. Symptoms indicate a faulty upper limit switch. Do the following:

1. Make sure the 2-pin plug that connects the upper limit switch to P/J8 on the control board is plugged in and connected properly.
2. Swap the upper limit switch or test it with an ohmmeter. The switch closes when the paper stack lifts the upper limit off the switch lever.
3. Swap the control board.

Figure 11–5 LCIT Elevator Motor Connectors

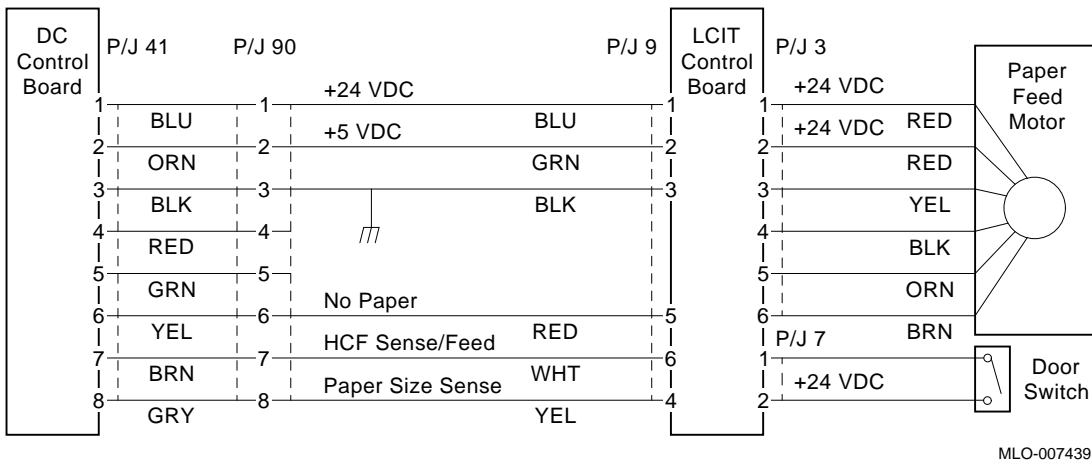
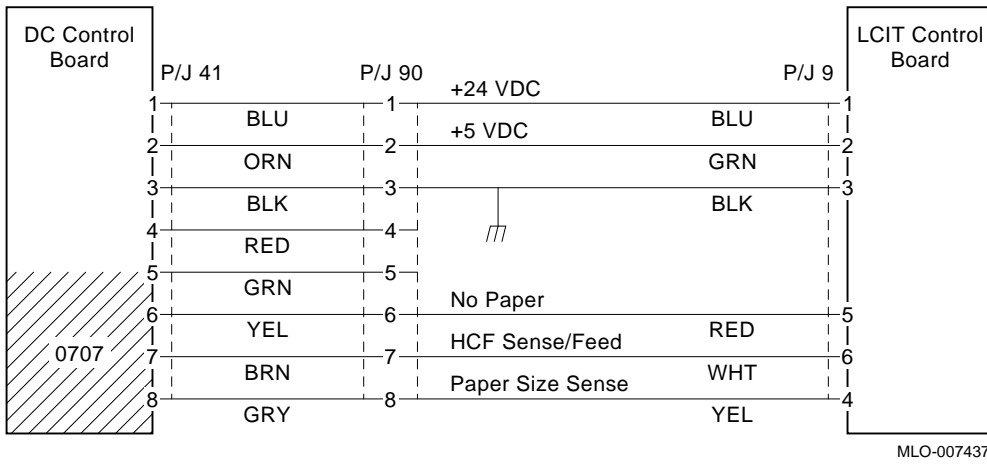

## 11.2 LCIT FIPS

### 11.2.1 Error Code LCIT FIPS

Table 11–4 shows all the DEClaser 3200 control panel error codes that relate to the LCIT.

**Table 11–4 LCIT Error Code Lookup Table**

Display Code	Full description	Brief Definition
0703	Section 5.13	<sup>1</sup> LCIT paper-out sensor detects empty LCIT.
0707	Section 5.16	<sup>1</sup> LCIT is missing or not fully installed
0823	Section 6.2.5	<sup>1</sup> LCIT preregistration jam
0830	Section 6.5.2	<sup>1</sup> Bypass trailing edge jam
0833	Section 6.5.5	<sup>1</sup> LCIT trailing edge shingle jam
1020	Section 6.6	<sup>1</sup> Fuser jam when feeding from bypass slot
1023	Section 6.6	<sup>1</sup> Fuser jam when feeding from LCIT

<sup>1</sup>Printing stops until operator attends to the offending problem. To clear this error, a door or sensor needs to actuate.

## 11.3 Tray Parallelism Adjustment

Skewing and jamming result when the elevator tray is not parallel to the feed rollers. Under normal operating conditions, tray parallelism should never need adjustment. Adjustment is required when parts of the elevator tray or lifting belts have been replaced or disassembled.

Use the following procedure to check and adjust the parallelism of the elevator tray to the feed roller:

1. Press the elevator switch to lower the elevator and remove the paper.
2. Press the door switch to raise the elevator.
3. Allow the elevator to rise until one or both feed rollers just touch the tray's surface.
  - If both feed rollers contact the tray, the parallelism is all right.
  - If the gap between one of the feed rollers and the tray surface is greater than 5 mm (0.197 in), do the following adjustment.
4. Power down the printer and unplug the LCIT printer cable.

**Warning:** *Do not work on the elevator when the LCIT is under power.*

## 11.3 Tray Parallelism Adjustment

5. Remove the front and rear covers, as shown in Section 11.4.1, Section 11.4.2, and Section 11.4.3.
6. Loosen the one or both elevator belt clamps (shown in Figure 11–3 and Figure 11–4) that hold the elevator tray to the lift belts and adjust the tray so it is parallel to the feed rollers.

## 11.4 LCIT Removal and Replacement Procedures

This section contains a removal and replacement procedure for major assemblies, FRUs, and associated components of the large-capacity input tray option of the DEClaser 3200 printer. See Table 11–2 and Table 11–3 to locate an FRU and obtain its part number. See Chapter 9 for DEClaser 3200 removal and replacement procedures.

The removal of most FRUs requires the removal of other components. For that reason, a procedural step can refer you to another procedure. For example, to remove the DC control board, you must perform the procedures to remove the upper cover and rear panel.

To remove an FRU, find the procedure and then follow the steps. To replace an FRU, reverse the procedure, unless otherwise noted.

The LCIT used for the photographs in this book is an engineering prototype. You may notice some cosmetic differences between the printer shown and the printer that you see in the field. These differences include the logos, labels, and colors of the panels and covers.

**Warning:** *Before you disassemble the LCIT, make sure the power switch is off and the ac line cord is disconnected from the rear of the printer.*

## 11.4 LCIT Removal and Replacement Procedures

### 11.4.1 Top Cover

Use the following procedure to remove and replace the top cover from the LCIT:

1. Power down the printer and unplug the LCIT.
2. Remove the four screws from the top cover.
3. Lift and remove the top cover.

MLO-006954

## 11.4 LCIT Removal and Replacement Procedures

### 11.4.2 Front Cover

Use the following procedure to remove and replace the front cover from the LCIT:

1. Power down the printer, and unplug the LCIT.
2. Remove the top cover, as shown in Section 11.4.1.
3. Loosen the single screw that holds the cover to the bulkhead.

MLO-006955

## 11.4 LCIT Removal and Replacement Procedures

4. Remove the two screws that hold the cover to the bulkhead.
5. Remove the front cover.

MLO-006956

## 11.4 LCIT Removal and Replacement Procedures

### 11.4.3 Rear Cover

Use the following procedure to remove and replace the rear cover from the LCIT:

1. Power down the printer and unplug the LCIT.
2. Remove the top cover, as shown in Section 11.4.1.
3. Loosen the single screw that holds the cover to the bulkhead.

MLO-006957

## 11.4 LCIT Removal and Replacement Procedures

4. Remove the two screws that hold the cover to the bulkhead.
5. Unplug the 2-pin connector that connects the elevator down switch to J5 on the control board.
6. Remove the rear cover.

MLO-006958

## 11.4 LCIT Removal and Replacement Procedures

### 11.4.4 Elevator Motor

Use the following procedure to remove and replace the elevator motor from the LCIT:

1. Power down the printer and unplug the LCIT.
2. Remove the top and front covers, as shown in Section 11.4.1 and Section 11.4.2.
3. Disconnect the plug ❶ that connects the elevator motor to the wire harness.
4. Cut the wire wrap ❷ and separate the leads.
5. Open the restraint clip ❸ and remove the wires.
6. Remove the E-ring ❹ and the large gear.

MLO-006959

## 11.4 LCIT Removal and Replacement Procedures

7. Remove the three screws that hold the drive assembly to the bulkhead. Each screw has a small outside washer ⑤ and a large inside washer ⑥.
8. Remove the drive assembly and remove the motor from it.

MLO-006960

## 11.4 LCIT Removal and Replacement Procedures

### 11.4.5 Feed Motor

Use the following procedure to remove and replace the feed motor from the LCIT:

1. Power down the printer and unplug the LCIT.
2. Remove the top and front covers, as shown in Section 11.4.1 and Section 11.4.3.
3. Unplug the 6-pin connector ❶ from J3 of the control board.
4. Remove the two screws and washers and remove the feed motor. Each screw has a small washer outside and a large washer inside.

MLO-006961

## 11.4 LCIT Removal and Replacement Procedures

### 11.4.6 Control Board and Size Jumper

Use the following procedure to remove and replace the LCIT control board from the LCIT:

1. Power down the printer and unplug the LCIT.
2. Remove the top and front covers, as shown in Section 11.4.1 and Section 11.4.3.
3. Unplug the following connectors from the control board:
  - ❶ J2 6-pin, elevator motor connector
  - ❷ J3 6-pin, paper feed motor connector
  - ❸ J4 2-pin, lower limit switch connector
  - ❹ J5 2-pin, elevator switch
  - ❺ J7 2-pin, door switch connector
  - ❻ J9 6-pin, input power connector
  - ❼ J6 2-pin, paper-out switch connector
  - ❽ J8 2-pin, upper limit switch connector
4. Remove the four screws and remove the LCIT control board.
5. When replacing the control board check the following:
  - Make sure to install the plastic washers, next to the circuit board, on each side of the screw.
  - Make sure the size jumper is configured for the correct paper size.

## 11.4 LCIT Removal and Replacement Procedures

MLO-006962

## 11.4 LCIT Removal and Replacement Procedures

### 11.4.7 Paper-Out Sensor (Switch)

Use the following procedure to remove and replace the paper-out sensor from the LCIT:

1. Power down the printer and unplug the LCIT.
2. Remove the top and front covers, as shown in Section 11.4.1 and Section 11.4.2.
3. Unplug the two connectors from the switch.
4. Remove the two bolts that hold the switch to the bulkhead.
5. Remove the paper-out switch from the mounting studs.

MLO-006963

## 11.4 LCIT Removal and Replacement Procedures

### 11.4.8 Lower Limit Switch

Use the following procedure to remove and replace the lower limit switch from the LCIT:

1. Power down the printer and unplug the LCIT.
2. Remove the top and front covers, as shown in Section 11.4.1 and Section 11.4.3.
3. Unplug the two connectors from the switch.
4. Remove the two bolts that hold the switch to the bulkhead.
5. Remove the paper-out switch from the mounting studs.

MLO-006966

## 11.4 LCIT Removal and Replacement Procedures

### 11.4.9 Upper Limit Switch

Use the following procedure to remove and replace the upper limit switch from the LCIT:

1. Power down the printer and unplug the LCIT.
2. Remove the top and rear covers, as shown in Section 11.4.1 and Section 11.4.3.
3. Unplug the two connectors ❶ from the switch.
4. Remove the two bolts that hold the switch to the bulkhead.
5. Remove the upper limit switch from the mounting studs.

MLO-006967

## 11.4 LCIT Removal and Replacement Procedures

### 11.4.10 Door Switch

Use the following procedure to remove and replace the door switch from the LCIT:

1. Power down the printer and unplug the LCIT.
2. Remove the top and front covers, as shown in Section 11.4.1 and Section 11.4.3.
3. Unplug the two connectors from the switch.
4. Remove the two bolts that hold the switch to the bulkhead.
5. Remove the door switch from the mounting studs.

MLO-006968

## 11.4 LCIT Removal and Replacement Procedures

### 11.4.11 Paper Feed Rollers

Use the following procedure to remove and replace the paper feed rollers from the LCIT:

1. Power down the printer and unplug the LCIT.
2. Remove the top cover, as shown in Section 11.4.1.
3. Remove the two E-rings ❶.  
**Caution:** *Do not get grease on the surface of the feed rollers. It degrades the life of the roller and can cause skewing or feed jams.*
4. Disengage the feed roller shaft ❷ from the two end brackets ❸.
5. Remove and replace the feed rollers.
6. When you replace the feed rollers, turn them by hand ❹ to check the operation of the clutches. Both rollers must turn freely in the clockwise (CW) or feeding direction while resistance is felt when turning in the counterclockwise (CCW) direction.

## 11.4 LCIT Removal and Replacement Procedures

MLO-006969 MLO-006971



# A

---

## Supplemental Information

This appendix contains general information that you may find useful.

### A.1 Interface Interconnections

The DEClaser 3200 printer can connect to a host system through the 8-bit parallel bus or through the serial port. You select a port through the COM INTERFACE feature of the Set Up menu, as shown in Figure 2-4.

#### A.1.1 Parallel Port

The parallel port uses a Centronics interface protocol and a 36-pin connector. Figure A-1 shows the shape, pin configuration, and a signal diagram of the parallel port. Table A-1 gives the pin numbers and signal names.

**Figure A-1 Parallel Port Connector**

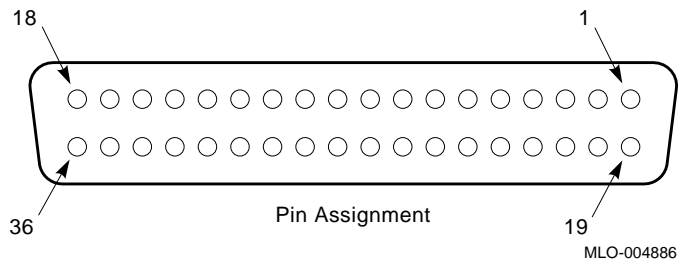

(continued on next page)

## A.1 Interface Interconnections

Figure A-1 (Cont.) Parallel Port Connector

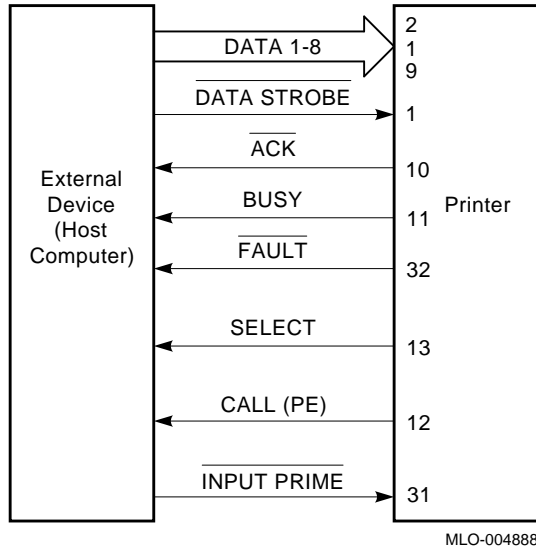

Table A-1 Parallel Interface Pin Assignment

Pin	Direction	Signal	Description
1	To printer	STROBE L	STROBE pulse low to read data. A strobe low signal will raise BUSY line to high.
2	To printer	DATA BIT 1 <sup>1</sup>	
3	To printer	DATA BIT 2 <sup>1</sup>	
4	To printer	DATA BIT 3 <sup>1</sup>	
5	To printer	DATA BIT 4 <sup>1</sup>	
6	To printer	DATA BIT 5 <sup>1</sup>	
7	To printer	DATA BIT 6 <sup>1</sup>	
8	To printer	DATA BIT 7 <sup>1</sup>	
9	To printer	DATA BIT 8 <sup>1</sup>	

<sup>1</sup>These signals are the 1st to the 8th bits of parallel data and are active high for a logical 1.

(continued on next page)

## A-2 Supplemental Information

## A.1 Interface Interconnections

**Table A–1 (Cont.) Parallel Interface Pin Assignment**

Pin	Direction	Signal	Description
10	From printer	ACKNLG L	ACKNLG pulse low indicates data received and ready to receive more data.
11	From printer	BUSY H	BUSY "high" indicates the printer cannot receive data (buffer full). BUSY high occurs when the printer is paused or an error condition exists. The polarity of this signal is selectable from the Set Up menu.
12	From printer	PE H	PAPER END high signal indicates paper out.
13	From printer	SLCT H	A high signal indicates the printer is in the select state.  A low signal occurs when printer is de-selected or if an error condition exists.
14	From printer	Ground	
15	From printer	Stunt box signal	2 MHz clock
16	From printer	0 Volts	Logic ground
17			Chassis Ground
18	From printer	+5 volts	
19-29	0 Volts		TWP returns all at Logic ground
30	0 Volts		INIT ground
31	To printer	INIT L	INIT L (low) resets the printer to its initial state and clears the buffer. The printer must see a pulse > 50 microseconds to activate this signal.
32	From printer	ERRORL	Goes low when an error condition occurs in the printer.
33	Open		
34	Not used		
35	Ground		
36	From printer	DP Busy	Not used

## A.1 Interface Interconnections

### A.1.2 Serial Port

The serial port connector accepts the standard 6-pin MMJ connector and is mechanically and electrically compatible to the EIA-423-A and CCITT V.10 interface specifications. Table A-2 lists the pin numbers, signal names, direction, and the wiring connections inside a null modem cable. Pin numbers that are not mentioned are not used.

**Table A-2 Serial Interface**

DEConnect				
Pin	Direction	Name	RS-423 Function	EIA-232 Equivalent
1	From printer	TR	TERMINAL READY	CD
2	From printer	SD	SEND DATA	BA
3	From printer	–	SEND COMMON	–
4	To printer	–	RECEIVE COMMON	–
5	To printer	RD	RECEIVE DATA	BB
6	To printer	DM	DATA SET READY	CC

## A.2 Interface Cables and Adapters

Table A-3 gives the adapters you need to connect the various host systems to the DEClaser 3200 printer.

**Note:** *For a complete list of accessories and supplies and instructions on how to order them, refer to the DEClaser 3200 Printer Operator's Guide.*

## A.2 Interface Cables and Adapters

**Table A-3 Cables and Adapters**

Connector Type	System Type	System, Cable, and Printer Adapters
25-Pin Plug Connector	VAXstation 3200/3500 VT100 Series DECserver 200/MC (DSRVB-AA) CPU RS232 Ports	H8571-A (25-pin-to-MMJ) BC16E <sup>1</sup> H8571-E <sup>1</sup>
9-Pin Plug Devices (DEC)	VT200 Series DECmate PRO Series VAXstation 2000	H8571-B (9-pin-to-MMJ) BC16E <sup>1</sup> H8571-E <sup>1</sup>
DEC423 (MMJ) Serial Devices	VAXmate Microvax 2000 DECserver 300 DECserver 200/DL (DSRVB-BA) VT300 Series CPU DEC423 Ports	BC16E <sup>1</sup> H8571-E <sup>1</sup>
25-Pin Socket Devices	Rainbow Digital Modems	H8571-D BC16E <sup>1</sup> H8571-E <sup>1</sup>
9-Pin Socket Devices (IBM PC/AT Type)	DECstation 210, 212 DECstation 316, 320 IBM PC/AT	H8571-J BC16E <sup>1</sup> H8571-E <sup>1, 2</sup>
European DECstations Serial Port	200 Series  300, 350 Series	12-27591-01 extender cable H8571-A BC16E <sup>1</sup> H8571-E <sup>1</sup>  H8571-A BC16E <sup>1</sup> H8571-E <sup>1</sup>
European DECstations IBM/Centronics Parallel Port	200, 300, 350 Series	BC19M-10

<sup>1</sup>H8571-E and BC16E (DECconnect cable) are included with the DEClaser 3200 printer.

<sup>2</sup>Use data transmit ready (DTR) flow control. Refer to the *DEClaser 3200 Printer Operator's Guide*.

(continued on next page)

## A.2 Interface Cables and Adapters

**Table A–3 (Cont.) Cables and Adapters**

Connector Type	System Type	System, Cable, and Printer Adapters
Existing Cable	BC22D cable (already installed)	H8571–C BC16E <sup>1</sup> H8571–E <sup>1, 3</sup>

<sup>1</sup>H8571–E and BC16E (DECconnect cable) are included with the DEClaser 3200 printer.

<sup>3</sup>The combination of the H8571–C adapter, the BC16E cable, and the H8571–E acts as a straight-through cable.

## A.3 Accessories and Supplies

This appendix lists the accessories and supplies available for the DEClaser 3200 printer through the DECdirect catalog.

**Table A–4 Accessories and Supplies**

Part Number	Description
LN08X–CA	CG Times proportional font cartridge
LN08X–CB	CG Triumvirate proportional font cartridge
LN08X–CC	ITC Souvenir and Script font cartridge
LN08X–CD	Monospaced font cartridge
LN08X–CF	Blank 256KB font cartridge
LN08X–CG	Blank 512K font cartridge
LN08X–CH	WordPerfect PCL font cartridge
LN08X–CI	Microsoft PCL font cartridge
LN08X–MA	2-MB SIMM
LN08X–CP	Numeric coprocessor
LN08X–UA	PostScript upgrade kit
LN08X–UB	PostScript ROM module
LN08X–TE	Multi-media feeder (MMF)
LN08X–TF	Large capacity input tray for Letter-size paper
LN08X–TG	Large capacity input tray for A4-size paper
LN08X–TD	Variable size paper cassette

(continued on next page)

## A.3 Accessories and Supplies

**Table A-4 (Cont.) Accessories and Supplies**

<b>Part Number</b>	<b>Description</b>
LN08X-TC	Letter-size paper cassette
LN08X-TB	Legal-size paper cassette (8½in. x 14 in.)
LN08X-TA	A4-size paper cassette (297 mm x 182 mm)
LN01X-AB	Letter-size paper 8 ½ in. x 11 in. 5,000 sheets per box
LN01X-AD	A4-size paper 297 mm x 210 mm 5,000 sheets per box
LN01X-AC	Legal-size paper 8 ½ in. x 14 in. 5,000 sheets per box
LN03X-AJ	Letter-size transparencies 8 ½ in. x 11 in. 50 sheets per box
LN03X-AK	A4-size transparencies 297 mm x 210 mm 50 sheets per box
H9850-TA	Laser labels (30/sheet x 100 sheets per box)
H9850-TB	Laser labels (21/sheet x 100 sheets per box)
LN08X-AA	Toner cartridges (quantity = 2)
LN08X-AB	Photoreceptor drum cartridge (with fuser wick)
LN08X-AC	Developer cartridge (including transfer/separation charger and toner cartridge).
BC19M-10	IBM/Centronics parallel cable

## A.4 Connector Locations

### A.4 Connector Locations

Figure A-2 shows the location of each connector in the upper portion of the DEClaser 3200 printer.

Figure A-2 Connector Locations

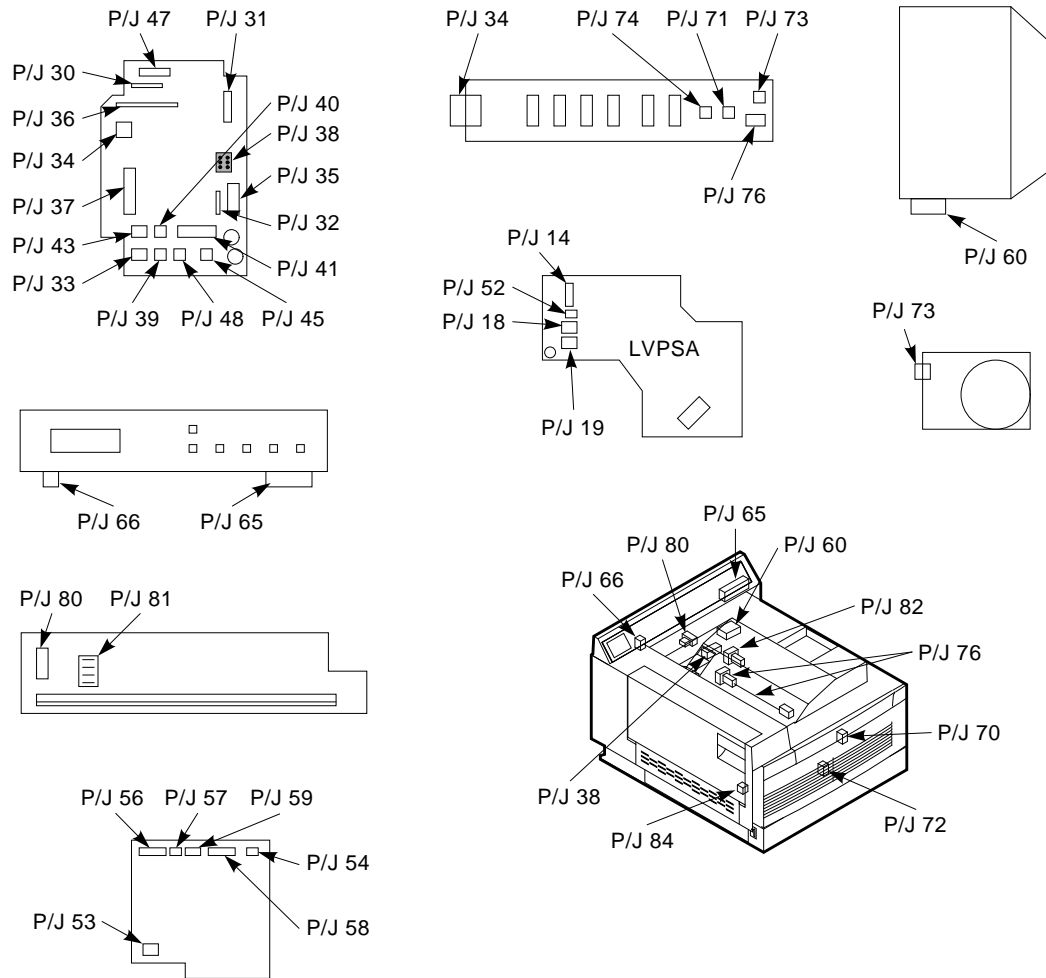

MLO-006685

### A.5 DC Power Distribution

The following wiring diagrams are used for extensive troubleshooting or for wiring harness problems:

- Figure A-3, 15 Vdc Distribution
- Figure A-4, Overall Distribution
- Figure A-5, 5 Vdc Distribution
- Figure A-6, 24 Vdc Distribution

**Figure A-3 15 Vdc Distribution**

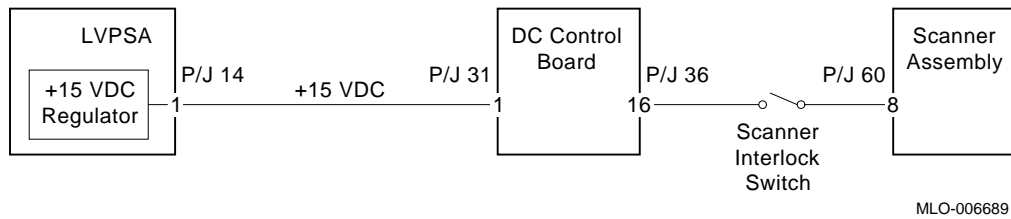

## A.5 DC Power Distribution

Figure A-4 Overall Distribution

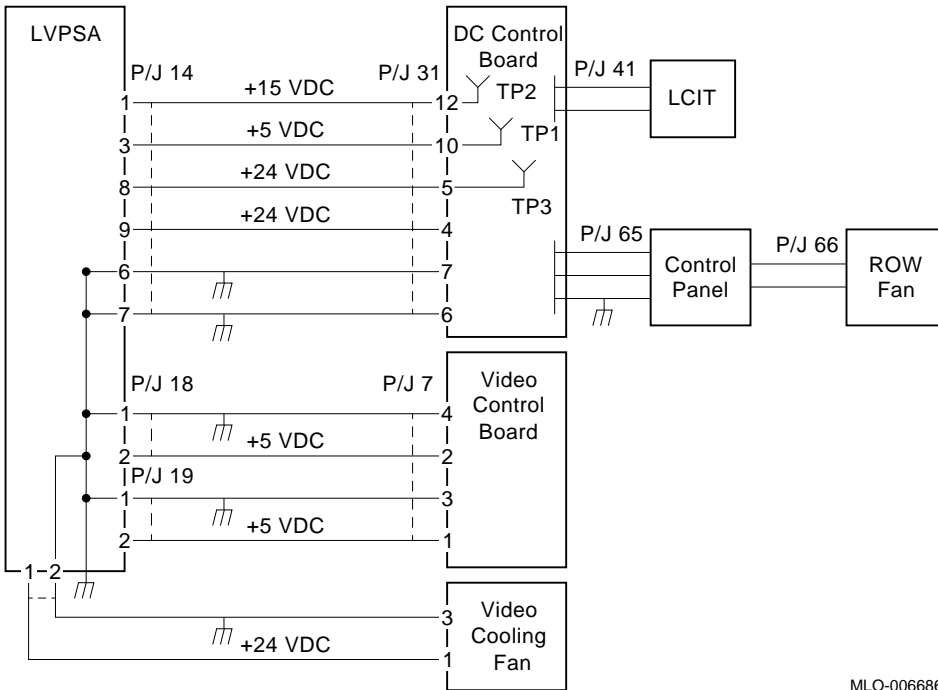

MLO-006686

Figure A-5 5 Vdc Distribution

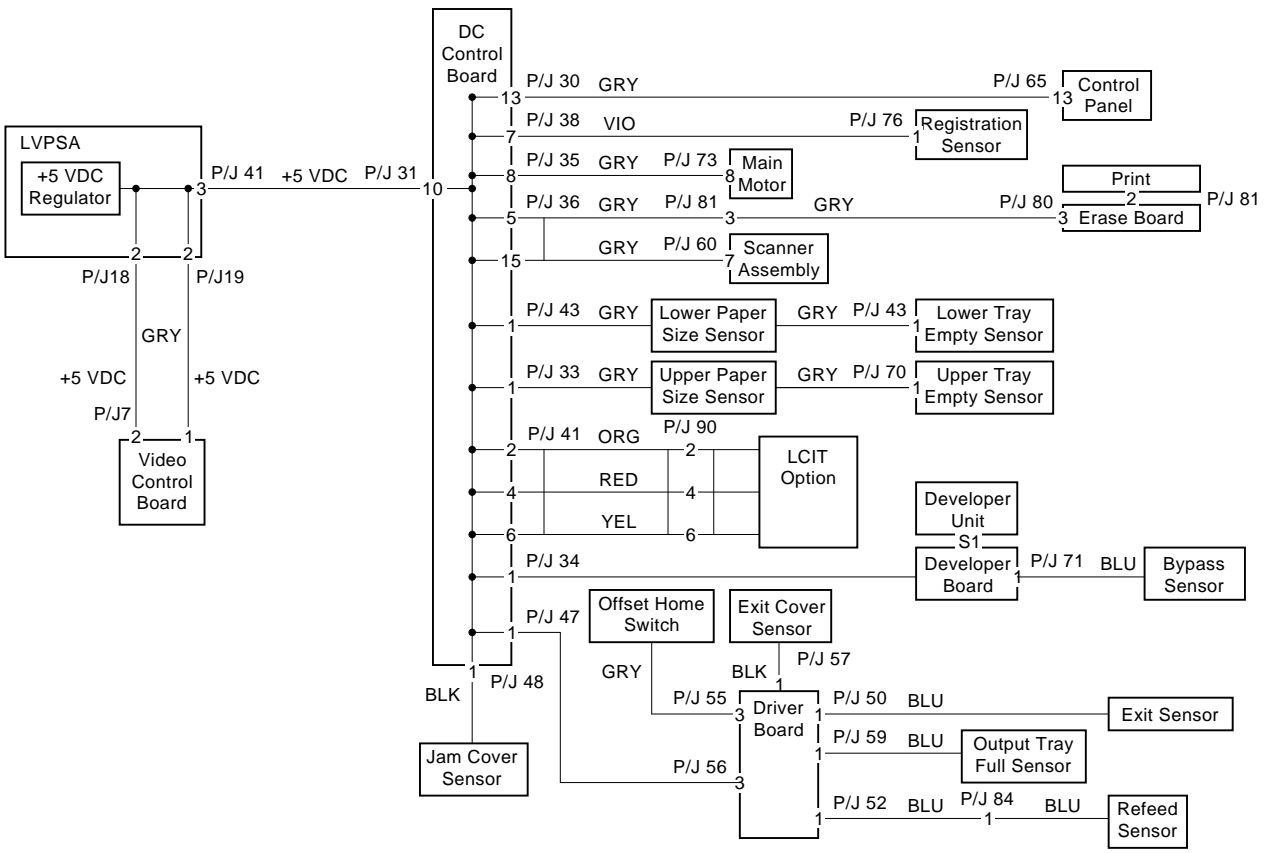

MLO-006687

Figure A-6 24 Vdc Distribution

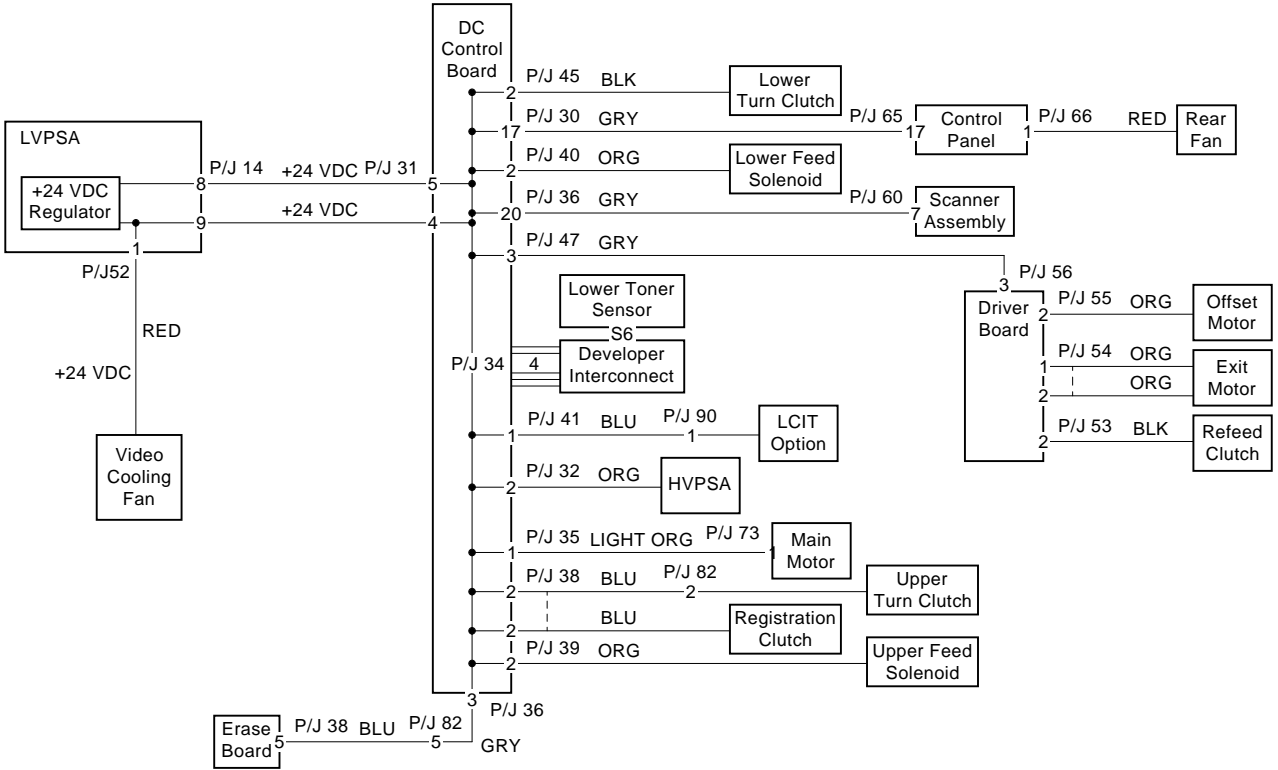

MLO-006688

---

## DEClaser 3200 Specifications

This appendix gives general specifications for the media and operation of the DEClaser 3200 printer.

### B.1 Paper Handling and Storage

Even if the customer is using paper that meets all specifications, improper handling and storage can alter paper quality and printer performance. Paper jams, misfeeding, and image defects are directly traceable to the mishandling and improper storage of paper.

#### Paper Handling

Be aware of the following considerations when handling paper:

- Load the cassette to its proper capacity rather than adding small amounts at a time.
- When you unwrap a new package of paper, discard the top and bottom sheets, as they tend to absorb more humidity from the surrounding environment.
- Load the paper in the cassette with the top side up. On most paper packages, an arrow indicates the top side of the paper.

#### Paper Storage

Be aware of the following considerations when storing paper:

- Do not unwrap paper until you are ready to load the cassette. The wrapping paper protects the paper against humidity.
- Do not store paper directly on the floor because floors are generally very damp.
- Lay paper on a flat surface to prevent in-ream paper curl.

## B.2 Print Media

## B.2 Print Media

The types of print media described in this section are paper, labels, transparencies, and envelopes. For additional information about print media, consult the *Digital Laser Printers Guide to Paper and Other Media*, available from DECdirect.

**Caution:** *Always select print media according to the instructions and specifications in this chapter. When selecting paper or other print media, print test samples on the paper you want to use. Be sure to consider the heat limitations of transparencies and the glues used on envelopes and labels. The inks and pigments used on chemically treated or coated paper (such as preprinted forms or colored paper) must also be able to withstand the high heat and pressure of the fusing unit. Otherwise damage to the printer may result.*

### B.2.1 Paper for Cassette Feeding

The manual feed tray can accommodate paper sizes ranging from 97 mm x 148 mm to 216 mm x 356 mm. Table B-1 lists the paper sizes that can be used with the optional paper cassettes for the printer.

**Table B-1 Cassette Feed Paper Sizes**

Paper Size	Dimensions
A4	210 mm x 297 mm
Executive	7 ¼ in. x 10 ½ in.
Letter	8 ½ in. x 11 in.
Legal	8 ½ in. x 14 in.

Table B–2 lists paper specifications for the DEClaser 3200 printer.

**Table B–2 Paper Specifications**

<b>Category</b>	<b>Specification</b>
Paper weight: plain paper	60 g/m <sup>2</sup> to 90 g/m <sup>2</sup> basis weight (16 lb. to 24 lb.)
Paper weight: envelopes	60 g/m <sup>2</sup> to 90 g/m <sup>2</sup> basis weight (16 lb. to 24 lb.)
Moisture content	4% to 6%
Thickness	0.086 mm to 0.107 mm
Smoothness	100–300 Sheffield
Brightness	84% minimum recommended
Cotton (rag) content	25% maximum
Opacity	85% opaque minimum

**B.2.1.1 Special Considerations When Printing on Paper**

Because of the way laser printers print and bond toner to the paper, you must observe some special requirements with certain types of papers:

- Do not use preprinted papers that do not meet the specifications for heat tolerance. The ink from some preprinted papers, such as those with a company letterhead, can cause smearing and in some extreme cases could damage the printer.
- Do not use colored papers in which the color is applied as a coating to the surface.
- Do not use thermal papers.
- Do not use carbon papers.
- Do not use paper printed with thermographics letterheads.

**B.2.2 Envelope Specifications**

The DEClaser 3200 printer accepts the following sizes of envelopes for use with the manual feed tray:

- #10 Business (4.12 x 9.5 in.)
- Business (9 in. x 12 in.)
- Business (10 in. x 13 in.)
- C4 (229 mm x 324 mm)

## B.2 Print Media

- C5 (162 mm x 229 mm)
- DL or C5/6 (110 mm x 220 mm)

Envelopes must meet the same specifications as paper (see Table B–2). In addition, the following types of envelopes cannot be used with the printer:

- Envelopes with sealing flaps that are open
- Envelopes with sealing flaps at the leading and trailing edges
- Envelopes with three or more layers of paper at the leading and trailing edges
- Envelopes that have transparent windows
- Envelopes that have clasps, snaps, or strings

### B.2.2.1 Special Considerations When Printing on Envelopes

Observe the following requirements when printing on envelopes:

- Feed envelopes from the manual feed tray one at a time.
- Print envelopes only on the front side.
- Since you need to print addresses in a particular area on envelopes, you must specify the proper print coordinates to print the addresses.
- Printing in the 15 mm (3/5 in.) border around the envelope may cause print quality problems with some types of envelopes. For best print quality, do not print in this border.

## B.2.3 Transparency Specifications

Table B–3 and Table B–4 contain information on the sizes and specifications of transparencies that can be used with the DEClaser 3200 printer.

**Table B–3 Transparency Sizes**

Transparency Size	Dimensions
A4	210 mm x 297 mm
Letter	8 ½ in. x 11 in.

**Table B–4 Transparency Specifications**

Category	Specification
Transparency weight	142±4 g/m <sup>2</sup> basis weight
Thickness	0.105±0.005 mm
Material	Polyester (coated)
Curl	5.0 mm

**B.2.3.1 Special Considerations When Printing on Transparencies**

Observe the following requirements when printing on transparencies:

- Feed transparencies from the manual feed tray one at a time.
- Remove transparencies from the output tray as each one is printed to prevent them from sticking to each other.

**B.2.4 Label Specifications**

A self-adhesive label consists of a face sheet, an adhesive sheet, and a carrier sheet. The carrier sheet and adhesive used for the labels must be able to meet the heat tolerance specification of 150°C (302°F) for at least 0.1 second.

**Caution:** *Exposed adhesive on labels can cause damage to the printer. To test for adhesive that may be exposed, press a plain piece of paper on top of the sheet of labels. If the paper sticks to the labels, do not use those labels.*

Table B–5 contains information on the sizes and specifications of self-adhesive labels that can be used with the DEClaser 3200 printer.

**Table B–5 Self-Adhesive Label Specifications**

Category	Specification
Face sheet	51±4 g/m <sup>2</sup> basis weight
Backing sheet	50±3 g/m <sup>2</sup> basis weight
Face sheet adhesive coating	15.5±2.5 g/m <sup>2</sup> basis weight
Total basis weight	116.5±9.5 g/m <sup>2</sup>
Total thickness	0.125±0.010 mm
Moisture content	4.5% to 7.0%

## B.2 Print Media

### B.2.4.1 Special Considerations When Printing on Labels

Observe the following requirements when printing on labels:

- Feed labels from the manual feed tray one sheet at a time.
- Be sure the carrier sheet is not exposed.
- Be sure no adhesive is exposed.

## B.3 Operating Specifications

Table B–6 is copied from the *DEClaser 3200 Printer Operator's Guide* and presents a condensed version of the operational specifications.

**Table B–6 DEClaser 3200 Specifications**

---

<b>Type:</b>	Desktop page printer
<b>Printing Method:</b>	Electrophotographic, using laser beam scanning
<b>Laser Power:</b>	10 mW maximum
<b>Resolution:</b>	300 dpi
<b>Printing Speed:</b>	Simplex: 13 pages/minute maximum, using A4 or Letter-size paper Duplex: 11 pages/minute maximum using A4 or letter-size paper
<b>Warm-Up Time:</b>	Less than one minute at 20°C (68°F)
<b>Paper Cassette:</b>	Approximate capacity is 250 sheets Letter (8 ½ in. x 11 in.) A4 (210 mm x 297 mm) Executive (7 ¼ in. x 10 ½ in.) Legal (8 ½ in. x 14 in.)
<b>Manual Feed:</b>	One sheet at a time 105 mm x 257 mm (4 ⅛ in. to 10.12 in. wide) 190 mm x 364 mm (7 ½ in. to 14.33 in. long)
<b>Output Tray Capacity:</b>	500 sheets (job offset facedown stacking)
<b>Paper Weight Range Cassette Feed:</b>	60 g/m <sup>2</sup> to 80 g/m <sup>2</sup> basis weight (16 lb. to 21 lb.)
<b>Paper Weight Range Manual Feed:</b>	60 g/m <sup>2</sup> to 90 g/m <sup>2</sup> basis weight (16 lb. to 24 lb.)
<b>Host Interface:</b>	Parallel (Centronics) and serial (RS423 MMJ configuration)

(continued on next page)

## B.3 Operating Specifications

**Table B-6 (Cont.) DEClaser 3200 Specifications**

---

<b>Acoustic Noise:</b>	53 dB(A) maximum during standby 55 maximum during printing
<b>Operating Temperature:</b>	10°C to 32°C (50°F to 90°F)
<b>Operating Humidity:</b>	20% to 80% relative humidity
<b>Storage Temperature:</b>	-20°C to 40°C (-4°F to 104°F)
<b>Storage Humidity:</b>	10% to 85% relative humidity
<b>Line Voltage:</b>	120 Vac, 60 Hz, 12 A max 220-240 Vac, 50 Hz, 7 A max
<b>Power Consumption:</b>	Running = 0.85 KW Standby = 0.3 KW
<b>Installed Weight:</b>	Approximately 38 kg (85 lb.)
<b>Dimensions:</b>	Width: 670 mm (26.4 in.) Depth: 536 mm (21.1 in.) Height: 496 mm (19.5 in.)
<b>Built-in RAM:</b>	0.5 MB, expandable to 10.5 MB with optional SIMs
<b>Font Cartridges:</b>	Capacity for two optional DEC PPL3 or HP Laser Jet II font cartridges
<b>DEC PPL3 Font Files:</b>	There are 36 built-in DEC PPL3 font files. The font files consist of four fonts and nine character sets. These fonts are: <ul style="list-style-type: none"><li>• Courier 10-point normal<sup>1</sup> portrait</li><li>• Courier 10.3-point normal portrait</li><li>• Courier 6.7-point normal landscape</li><li>• Elite 10-point normal portrait</li></ul>

---

<sup>1</sup>Normal means that the font is not set in bold or italics or otherwise attributed.

(continued on next page)

## B.3 Operating Specifications

**Table B-6 (Cont.) DEClaser 3200 Specifications**

---

<b>DEC PPL3 Character sets:</b>	For each DEC PPL3 font, the following character sets reside in the printer: <ul style="list-style-type: none"><li>• ASCII</li><li>• DEC Supplemental</li><li>• ISO Latin-1 Supplemental</li><li>• DEC Technical</li><li>• DEC Special Graphics (VT100 Line Drawing)</li><li>• DEC 7-Bit Hebrew</li><li>• DEC Hebrew Supplemental</li><li>• ISO Latin-Hebrew Supplemental</li><li>• Legal</li></ul>
-------------------------------------	--

---

# C

## DEClaser 3200 Total Call Concept (TCC)

As Figure C-1 shows, this appendix is Total Call Concept for DEClaser 3200 printer. Figure C-1 shows how Appendix C fits into the overall troubleshooting flow. If you follow a sequence of steps to fix one problem, return to Section 4.1, Start FIP.

**Figure C-1 Overall Troubleshooting Flow**

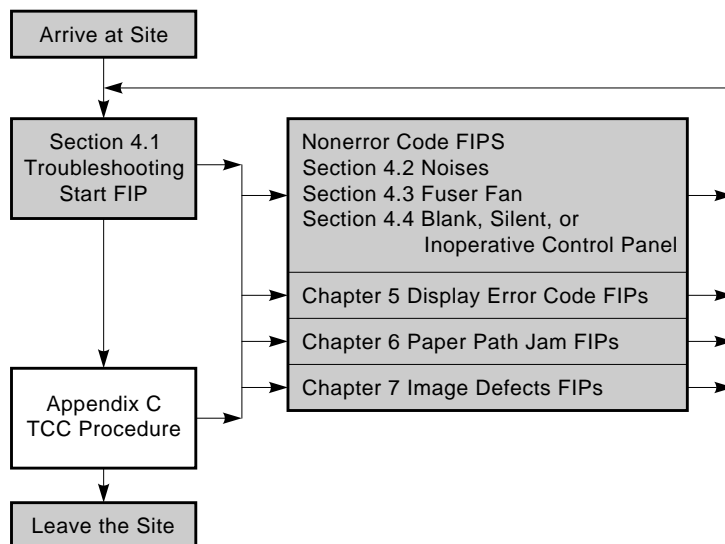

MLO-007647

## C.1 About TCC

### C.1 About TCC

The Total Call Concept (TCC) procedure is performed in concert with the Start FIP which is found in Section 4.1. When you perform the TCC procedure you enhance the reliability of the printer and reduce the number of service calls that are required to support the printer. Return to the Start FIP for troubleshooting information.

The Start FIP is a tool that you use to isolate a malfunction and find the specific FIP to turn to for further testing and repair.

### C.2 Cleaning and Inspection

Damaged, worn, or broken printer components cause intermittent problems and accelerate the aging of mechanical components. Vacuum the toner, paper dust, and dirt from all rollers, bearings, and gears. Inspect, clean, or replace all rollers. Look for flat spots, surface glazing, splitting, or dust and toner impregnation. Look for loose or missing screws; cracked, broken or bent paper path guides; nicked or frayed wires; and missing E-rings and disconnected springs.

If you are uncertain that a component is worn, broken, or contaminated but suspect that it is, replace it anyway. This preventive action will reduce the number of service calls over the lifetime of the printer.

**Caution:** *Always use the special vacuum cleaner shown in Table D-2 for cleaning up toner. The toner powder can pass through the bag or filter of a conventional vacuum cleaner and cause damage.*

Thoroughly inspect and clean the following parts of the printer:

- Inside and outside of both cassettes
- All paper path guides
- Fixing unit entrance and exit areas
- Exit rollers
- Exit stacking tray
- Remove and clean the case of the print drum cartridge. Inspect but do not clean the surface of the print drum.
- Remove and clean case of the developer cartridge
- Walls and floor of the empty print drum and developer cavity
- Inspect and clean the inside of the printer and look for toner spills, paper dust, or foreign objects.

## C.2 Cleaning and Inspection

- Transfer/separation charger, as shown in Section 10.6

## C.3 Tests and Checks

Perform the following checks and fix or replace any failing components:

1. Print a copy of the CONFIG SHEET, as shown in Section 2.6.
2. Do the following if the Page Count number on the CONFIG SHEET and the maintenance log show that the fusing unit has processed about 300,000 prints:
  - Replace the fusing unit, as shown in Section 9.28.
  - Whenever you replace the fusing unit, inspect the print drum ground clips. The ground clips wearout over time and must be replaced with the fuser unit at approximately 300,000 prints. See Section 9.17.2 for the removal and replacement procedure.
  - Clean the upper and lower paper feed rollers, as shown in Section 10.5.
3. Enter the page count number in the maintenance log.
4. Enter the 1701 test code 0202 or 0201 to check the control panel indicators. All the indicators must come on.
5. Enter the 1701 test code 0203 to check the display. All 32 blocks of the control panel display.
6. Enter the 1701 test code 0205 to check the control panel keys. Press all the keys saving \* for last.
7. If the current protocol is not DEC PPL3, set it so, as shown in Section 3.4.
8. Print a copy of the 1948 Setup test pattern, as shown in Section 3.3.
9. Make sure the image quality is good, all the numbered 1 lines are visible and unbroken, and the background is not stained.

## C.4 Final Test

Do the following final tests while you are filling out service call paperwork:

1. Print several simplex and duplex copies of the Grid test, as shown in Section 3.3. Use the offset motor when printing. This ensures the customer that the printer is functioning and in good operating order.
2. Make sure the printer's COMM INTERFACE values match the host system's baud, parity, and flow control values.

## C.4 Final Test

3. Make sure you restore the customer's protocol before you leave the site.
4. Ask the customer to print a file from the host system.
5. Fill out the printer maintenance log with parts replaced, type of problem, and the page count number. The page count is printed on the Config sheet, as shown in Figure 2-5, or can be displayed from the Test Print menu, as shown in Figure 3-3.
6. Before leaving, make sure the printer set up feature and values are restored to the proper settings. Place the maintenance log and light proof bag in the pocket at the rear of the printer.

## C.5 Maintenance Log

You must keep an accurate maintenance history to ensure the long life and reliability of the DEClaser 3200 printer. When you first arrive at the site, review the maintenance log for information that can assist you to troubleshoot and repair the malfunctioning printer. After you fix the problem, record your activity in the maintenance log for the benefit of the next service person.

The part number of the DEClaser 3200 Maintenance Log pad is, EN-02512-12.

A special adhesive-backed pouch is available for storing the maintenance log at the customer's site. The order number for the pouch is 36-18307-04. Attach the pouch to the bottom cover underneath the printer.

# D

---

## DEClaser 3200 Training, Tools, and Documentation

This appendix contains training, tools, and documentation information.

### D.1 Training

Before attempting to use this book and repair the printer, you must attend the specific Digital Education training course and all other prerequisite training courses.

The following table gives the ordering numbers and information about the courses.

**Table D–1 Training**

<b>Number</b>	<b>Description</b>
EY-F4873-PO	DEClaser SPI/lab training course is offered at FTC A and B sites worldwide.
<b>United States Training Prerequisite Courses</b>	
EY-7629E-IV	Hardcopy and video specialist core course
EY-5528E-IV	Laser safety and printer concepts course
<b>Europe and GIA Training Prerequisite Courses</b>	
EY-2830E-IV	Data Communication Fundamentals
EY-2239E-IV	Hardcopy Theory
EY-2423E-IV	Laser Printer Concepts
EY-2424E-IV	Laser Concepts and Safety

## D.2 Tools

## D.2 Tools

Table D–2 lists the ordering number of the tools that are needed to service the DEClaser 3200 printer in the field.

**Table D–2 Tools**

<b>Number</b>	<b>Description</b>
29–26106–00	50-Hz terminal tool kit
29–26109–00	60-Hz terminal tool kit
29–11762–00	Antistatic kit
29–26259–00	Vacuum <sup>1</sup> and attachments, 200 volts
29–25526–00	Vacuum <sup>1</sup> and attachments, 120 volts
29–26017–00	Filter bags and filter shell
29–26234–00	Cleaning kit
29–27340–01	Terminal tool kit
	Interlock tool <sup>2</sup>
	Conductive lubricating grease <sup>2</sup>
	Feed roller cleaning tool kit. Call support for kit ordering number and availability information.

<sup>1</sup>Special vacuum cleaner for toner powder

<sup>2</sup> This tool or component is included in the miscellaneous parts kit. See Table 8–1

### D.3 Documentation Ordering Information

Table D–3 lists the ordering numbers for this service guide and for other related DEClaser 3200 documentation.

**Table D–3 Documentation**

Number	Description
EK–LN08Z–DK	<p>The DEClaser 3200 Service Guide Documentation Kit includes the following:</p> <ul style="list-style-type: none"> <li>• <i>DEClaser 3200 Printer Service Guide</i> EK–LN08Z–SV</li> <li>• <i>DEClaser 3200 Maintenance Log pad</i> EN–02025–12 (Replacement pads can be ordered.)</li> </ul>
EK–D3200–DK	<p>The DEClaser 3200 Printer Documentation Kit consists of the following:</p> <ul style="list-style-type: none"> <li>• <i>DEClaser 3200 Printer Installation Guide</i> EK–DC32P–IN</li> <li>• <i>DEClaser 3200 Printer Operator’s Guide</i> EK–DC32P–OP</li> <li>• <i>DEClaser 3200 Printer Operator’s Quick Reference Guide</i> EK–DEC32–RF.</li> </ul>
EK–DL300–IP	<i>DEClaser 3200 Illustrated Parts Breakdown</i>
AA–PBWHA–TE	<i>Digital ANSI-Compliant Printing Protocol Level 3 Programming Supplement</i>
AA–PBWFA–TE	<i>PostScript Translators Reference Manual for ReGIS and Tektronix 4010/4014</i>
EK–LASER–GD	<i>Digital Laser Printers Guide to Paper and Other Media</i>



---

## Resident Protocols

This appendix provides information about the features and values available on the following three protocol submenus that you can select from the PROTOCOL feature of the Set Up menu that is described in Section 2.4. The resident protocols programs are in the video control board memory as opposed to a plug in cartridge. The PostScript protocol is optional.

- Section E.1, DEC PPL3 Submenu
- Section E.2, LJ2D Submenu
- Section E.3, PostScript Submenu

### E.1 DEC PPL3 Submenu

Figure E-1 shows the features that are available when DEC PPL3 is selected. See Figure 2-4 to see how this submenu connects to the Set Up menu diagram.

Figure E-1 DEC PPL3 Submenu

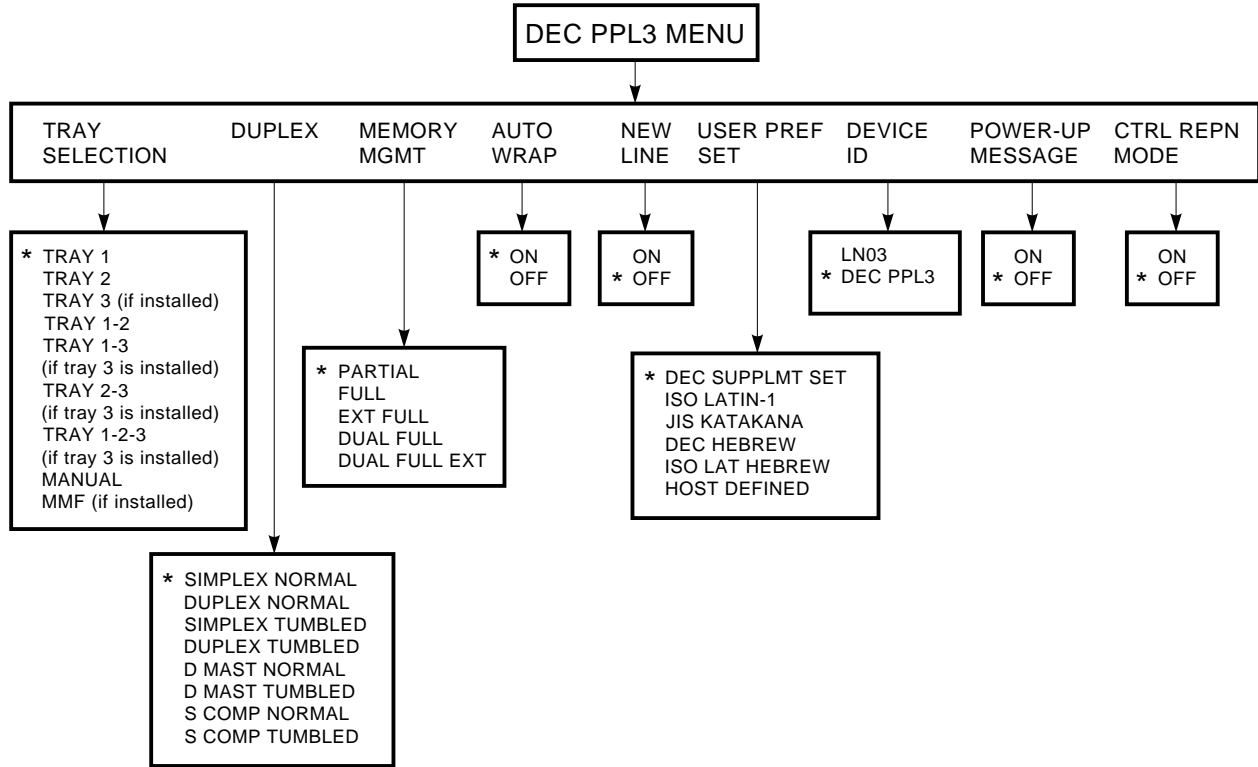

NOTE: The factory default is indicated with an asterisk.

MLO-006485

### E.1.1 TRAY SELECTION

This feature selects the following paper input feeder. In addition to selecting a singular tray, a sequence of trays can be selected to indicate the tray fail-over order.

Feature	Values	Description
TRAY	TRAY 1 <sup>1</sup>	Feeds paper from the upper paper cassette.
	TRAY 2	Feeds paper from the lower paper cassette.
	TRAY 3 <sup>2</sup>	Feeds paper from the optional LCIT.
	TRAY 1-2	When TRAY 1 is empty, feed paper from TRAY 2.
	TRAY 1-3 <sup>2</sup>	When TRAY 1 is empty, feed paper from TRAY 3.
	TRAY 2-3 <sup>2</sup>	When TRAY 2 is empty, feed paper from TRAY 3.
	TRAY 1-2-3 <sup>2</sup>	When TRAY 1 is empty, feed paper from TRAY 2. When TRAY 2 is empty, feed paper from TRAY 3.
	MANUAL	Selects the manual feed mode of operation.
	MMF <sup>3</sup>	Feeds paper from the optional MMF.

<sup>1</sup>Factory default setting.

<sup>2</sup>Displayed only if the LCIT option is installed.

<sup>3</sup>Displayed only if the MMF option is installed.

### E.1.2 DUPLEX

The following values are available from the DUPLEX submenu of the DEC PPL3 menu. A thorough explanation of the duplex values is beyond the scope of this guide. See the *DEC Laser 3200 Printer Operator's Guide* and the *Digital ANSI-Compliant Printing Protocol Level 3 Programming Reference Manual* for more information.

Feature	Values	Description
DUPLEX	SIMPLEX NORMAL <sup>1</sup>	Selects true simplex normal operation; binding is on the long edge.
	DUPLEX NORMAL	Selects true duplex normal operation; binding is on the long edge.
	SIMPLEX TUMBLED	Selects true simplex tumbled operation; binding is on the short edge.

<sup>1</sup>Factory default setting.

## E.1 DEC PPL3 Submenu

Feature	Values	Description
	DUPLEX TUMBLED	Selects true duplex tumbled operation; binding is on the short edge.
	D MAST NORMAL	Selects duplex master normal operation; binding is on the long edge.
	D MAST TUMBLED	Selects duplex master tumbled operation; binding is on the short edge.
	S COMP NORMAL	Selects simplex compressed normal operation; binding is on the long edge.
	S COMP TUMBLED	Selects simplex compressed tumble operation; binding is on the short edge.

### E.1.3 MEMORY MANAGEMENT

The following values are available under the MEMORY MGMNT submenu of the DEC PPL3 protocol.

Feature	Values	Description
MEMORY MGMT	PARTIAL <sup>1</sup>	Reserves no memory for bitmap pages. Memory is allocated dynamically.
	FULL <sup>2</sup>	Directs the printer to allocate memory space for one full bitmapped A4 or Letter-size page . The FULL setting eliminates page complexity errors but may slow the printer down if all pages require a full bitmap.
	EXT FULL <sup>2</sup>	Directs the printer to allocate memory space for one full bitmapped Legal-size page .
	DUAL FULL <sup>3</sup>	Directs the printer to allocate memory space for two full bitmapped A4 or Letter-size pages. The DUAL FULL setting allows you to print at a more efficient speed for documents that require full-page bitmaps for all pages.
	DUAL FULL EXT <sup>3</sup>	Directs the printer to allocate memory space for two full bitmapped Legal-size pages.

<sup>1</sup>Factory default setting.

<sup>2</sup>Displayed when at least 2.5 MB of optional RAM is installed.

<sup>3</sup>Displayed when at least 4.5 MB of optional RAM is installed.

### E.1.4 AUTO WRAP

The following values are available from the AUTO WRAP submenu of the DEC PPL3 protocol.

Feature	Values	Description
AUTO WRAP	ON <sup>1</sup>	When the print position reaches the right margin, it wraps to the left margin of the next line.
	OFF	Text is not wrapped to the next line when the right margin is reached. Text beyond the right margin is lost.

<sup>1</sup>Factory default setting.

### E.1.5 NEW LINE

The following values are available from the NEW LINE submenu of the DEC PPL3 protocol.

Feature	Values	Description
NEW LINE	ON	Advances to the next line upon receipt of a carriage return (CR) from the host computer.
	OFF <sup>1</sup>	The printer does not advance the paper to the next line when it receives a CR command.

<sup>1</sup>Factory default setting.

## E.1 DEC PPL3 Submenu

### E.1.6 USER PREF SET

The following values are available under the USER PREF SET submenu of the DEC PPL3 protocol.

Feature	Values	Description
USER PREF SET	DEC SUPPLMT SET <sup>1</sup>	Uses the DEC Supplemental character set.
	ISO LATIN-1	Uses the ISO Latin-1 character set.
	JIS KATAKANA	Uses the JIS Katakana character set.
	DEC HEBREW	Uses the DEC 7-bit Hebrew character set.
	ISO LAT HEBREW	Uses the ISO Latin Hebrew character set.
	HOST DEFINED	The character set is defined by the host computer.

<sup>1</sup>Factory default setting.

### E.1.7 DEVICE ID

The DEClaser 3200 can identify itself as a Digital ANSI-compliant Printing Protocol level 3 printer (DEC PPL3), and therefore can be recognized as such by symbionts and terminal drivers that conform to the Digital ANSI-compliant architecture. This identification is also compatible with level 2 devices, since all level 2 sequences are also supported.

The following values are available under the DEVICE ID submenu of the DEC PPL3 protocol.

Feature	Values	Description
DEVICE ID	DEC PPL3 <sup>1</sup>	The printer identifies itself as a DEC PPL3 printer.
	LN03	The printer identifies itself as an LN03 printer.

<sup>1</sup>Factory default setting.

### E.1.8 POWER-UP MESSAGE

The following values are available under the POWER UP MESSAGE submenu of the DEC PPL3 protocol.

Feature	Values	Description
POWER-UP MESSAGE	ON <sup>1</sup>	The printer sends an initialization message when the printer is turned on.
	OFF	No initialization message is sent when the printer is turned on.

<sup>1</sup>Factory default setting.

## E.2 LJ2D Submenu

### E.2 LJ2D Submenu

Figure E-2 shows the configuration and flow of the LJ2D protocol submenu. See Figure 2-4 to see how this submenu connects to the Set Up menu diagram. Use the following procedure to enter the LJ2D protocol menu:

1. Press  to set the printer to paused mode.
2. Press  to display the PROTOCOL text.
3. Press  to display the selected protocol. DEC PPL3 is factory default.
4. Press  to select LJ2D protocol.
5. Press  to enter the selection. An asterisk (\*) will appear.
6. If you wish the LJ2D protocol to remain invoked through power on/off cycles, make sure to save the user defaults, as shown in Section 2.5.

To exit from the Set Up menu, press  once or  as many times as necessary.

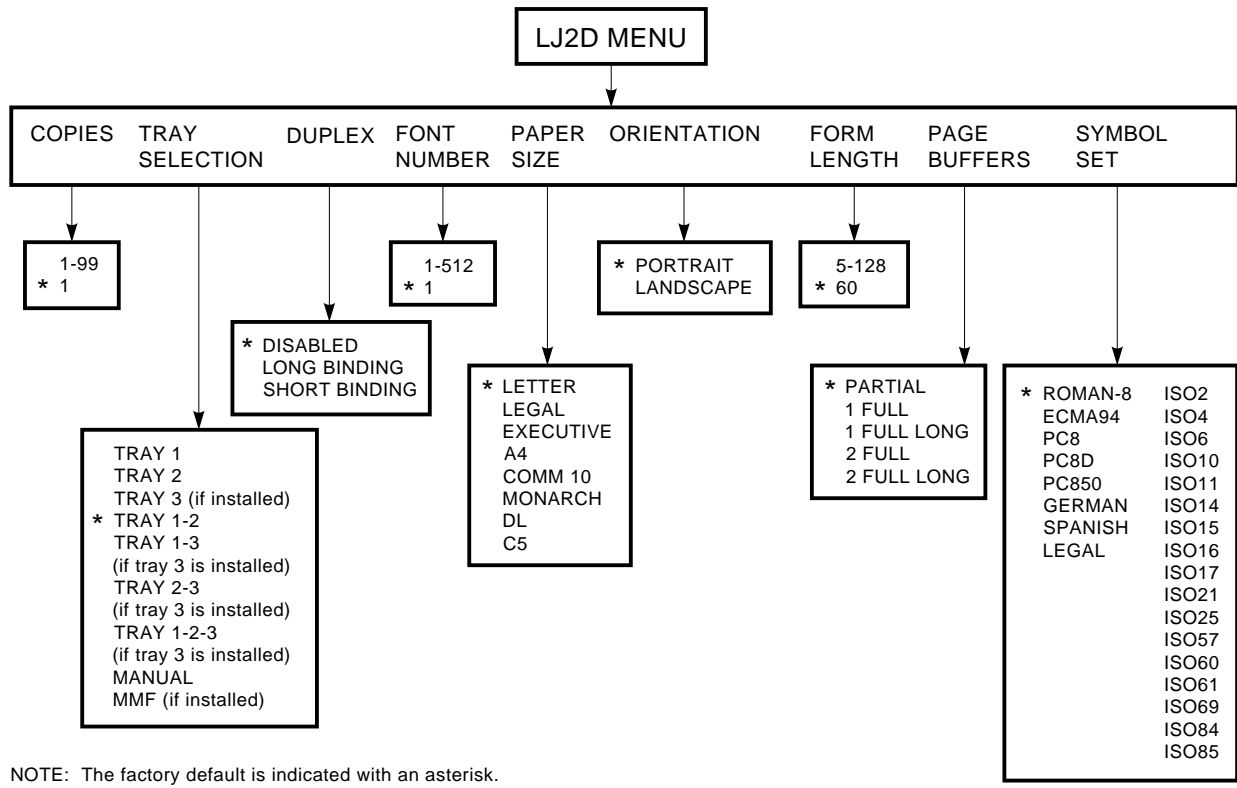

NOTE: The factory default is indicated with an asterisk.

MLO-006486

Figure E-2 LJ2D Submenu

## E.2 LJ2D Submenu

### E.2.1 COPIES

The following values are available on the COPIES submenu of the LJ2D protocol menu.

Feature	Values	Description
COPIES	01 <sup>1</sup> —99	Sets the number of copies to be printed.

<sup>1</sup>Factory default setting.

### E.2.2 TRAY SELECTION

The following values are available from the TRAY SELECTION submenu of the LJ2D protocol menu.

Feature	Values	Description
TRAY SELECTION	TRAY 1-2 <sup>1</sup>	When TRAY 1 is empty, feed paper from TRAY 2.
	MANUAL	Selects the manual feed mode of operation.
	TRAY 1	Feeds paper from the upper paper cassette.
	TRAY 2	Feeds paper from the lower paper cassette.
	TRAY 3 <sup>2</sup>	Feeds paper from the optional LCIT.
	TRAY 1-3 <sup>2</sup>	When TRAY 1 is empty, feed paper from TRAY 3.
	TRAY 2-3 <sup>2</sup>	When TRAY 2 is empty, feed paper from TRAY 3.
	TRAY 1-2-3 <sup>2</sup>	When TRAY 1 is empty, feed paper from TRAY 2. When TRAY 2 is empty, feed paper from TRAY 3.
MMF <sup>3</sup>	Feeds paper from the optional MMF.	

<sup>1</sup>Factory default setting.

<sup>2</sup>Displayed only if the LCIT option is installed.

<sup>3</sup>Displayed only if the MMF option is installed.

### E.2.3 DUPLEX

The following values are available from the DUPLEX submenu of the LJ2D protocol menu. A thorough explanation of the duplex values is beyond the scope of this guide. See *DECLaser 3200 Printer Operator's Guide* and *Digital ANSI-Compliant Printing Protocol Level 3 Programming Reference Manual* for more information.

Feature	Values	Description
DUPLEX	DISABLED <sup>1</sup>	Selects the simplex mode of operation.
	LONG BINDING	Selects the duplex mode of operation; binding is on the long edge.
	SHORT BINDING	Selects the duplex mode of operation; binding is on the short edge.

<sup>1</sup>Factory default setting.

#### E.2.4 FONT NUMBER

The following values are available on the FONT NUMBER submenu of the LJ2D protocol. See *Digital ANSI-Compliant Printing Protocol Level 3 Programming Reference Manual* and the *Digital ANSI-Compliant Printing Protocol Level 3 Programming Supplement* for more information.

Feature	Values	Description
FONT NUMBER	001 <sup>1</sup> –512	Identifies the font used to print. <ul style="list-style-type: none"> <li>• Font numbers 001–041 identify internal portrait fonts.</li> <li>• Font numbers 042–255 identify cartridge fonts.</li> <li>• Font numbers 256–297 identify internal landscape fonts.</li> <li>• Font numbers 298–512 identify cartridge fonts.</li> </ul>

<sup>1</sup>Factory default setting.

#### E.2.5 PAPER SIZE

The following values are available from the PAPER SIZE submenu of the LJ2D protocol.

## E.2 LJ2D Submenu

Feature	Values	Description
PAPER SIZE	LETTER <sup>1</sup>	Selects 8.5 in. x 11 in. size paper.
	LEGAL	Selects 8.5 in. x 14 in. size paper.
	EXECUTIVE	Selects 7~7.5 in. x 10~10.5 in. size paper.
	A4	Selects 210 mm x 297 mm size paper.
	COMMERCIAL 10	Selects 4.13 in. x 9.5 in. size envelopes.
	MONARCH	Selects 98 mm x 191 mm size envelopes.
	DL	Selects 110 mm x 220 mm size envelopes.
C5	Selects 162 mm x 229 mm size envelopes.	

<sup>1</sup>Factory default setting.

### E.2.6 ORIENTATION

The following values are available from the ORIENTATION submenu of the LJ2D protocol.

Feature	Values	Description
ORIENTATION	PORTRAIT <sup>1</sup>	Text and graphics are printed across the short-edge (width) of the page.
	LANDSCAPE	Text and graphics are printed across the long-edge (length) of the page.

<sup>1</sup>Factory default setting.

### E.2.7 FORM LENGTH

The following values are available from the FORM LENGTH submenu of the LJ2D protocol.

Feature	Values	Description
FORM LENGTH	.005	Indicates the number of lines to print on the page. To calculate the number of lines per inch (LPI), subtract 1 from the page length, then divide the sheet length into the number of lines.
	.	
	. 60 <sup>1</sup> .	
	.	
	. 128	

<sup>1</sup>Factory default setting.

### E.2.8 SYMBOL SET

The following values are available from the SYMBOL SET submenu of the LJ2D protocol. For information about selecting symbol sets and fonts see the *DEClaser 3200 Printer Operator's Guide* and the *Digital ANSI-Compliant Printing Protocol Level 3 Programming Reference Manual*.

Feature	Values	Values	Values
SYMBOL SET	ROMAN-8 <sup>1</sup>	ECMA94	PC8
	PC8DN	PC850	LJ GERMAN
	LJ SPANISH	LJ LEGAL	ISO2
	ISO4	ISO6	ISO10
	ISO11	ISO14	ISO15
	ISO16	ISO17	ISO21
	ISO25	ISO57	ISO60
	ISO61	ISO69	ISO84.
	ISO85		

<sup>1</sup>Factory default setting.

## E.3 PostScript Submenu

### E.3 PostScript Submenu

Figure E-3 shows a block diagram of the PostScript submenu. The PostScript protocol submenu appears only when the PostScript option is installed in the printer. See Figure 2-4 to see how this submenu connects to the Set Up menu diagram. Use the following procedure to enter the PostScript submenu:

1. Press  to set the printer to the paused mode.
2. Press  to display the PROTOCOL text.
3. Press  to display the selected protocol. DEC PPL3 is factory default.
4. Press  until the PostScript message is displayed.
5. Press  to enter the selection. An asterisk (\*) will appear.
6. If you wish the PostScript protocol to remain invoked through power on/off cycles, save the user defaults, as shown in Section 2.5.

To exit from the Set up menu, press  ounce or  as many times as necessary.

**Note:** *PostScript features and values are automatically saved in NVRAM when they are selected.*

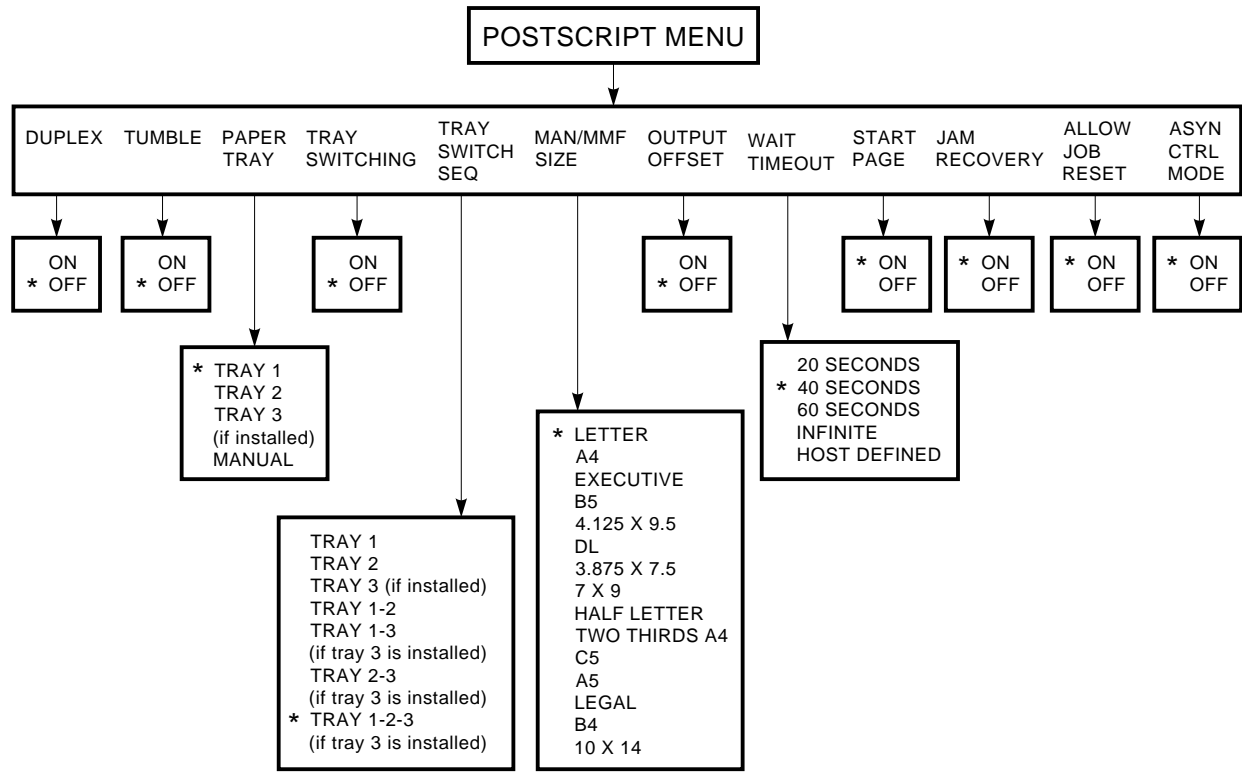

NOTE: The factory default is indicated with an asterisk.

MLO-006487

Figure E-3 PostScript Submenu

## E.3 PostScript Submenu

### E.3.1 DUPLEX

The following values are available on the DUPLEX submenu of the PostScript protocol menu.

Feature	Values	Description
DUPLEX	ON	Selects the duplex mode of operation.
	OFF <sup>1</sup>	Selects the simplex mode of operation

<sup>1</sup>Factory default setting.

### E.3.2 TUMBLE

The following values are available on the TUMBLE submenu of the PostScript protocol menu. A thorough explanation of the TUMBLE values is beyond the scope of this guide. See the *DEClaser 3200 Printer Operator's Guide*.

Feature	Values	Description
TUMBLE	ON	Binding is along the short edge of the paper.
	OFF <sup>1</sup>	Binding is along the long edge of the paper.

<sup>1</sup>Factory default setting.

### E.3.3 PAPER TRAY

The following values are available on the PAPER TRAY submenu of the PostScript protocol menu.

Feature	Values	Description
PAPER TRAY	TRAY 1 <sup>1</sup>	Feeds paper from the upper paper cassette.
	TRAY 2	Feeds paper from the lower paper cassette.
	TRAY 3 <sup>2</sup>	Feeds paper from the optional LCIT.
	MANUAL/MMF	Selects the manual feed mode of operation, or the optional Multi-media feeder if it is installed.  If you are using the manual feed tray, you must also indicate the proper paper size. See Section E.3.6 for information about the paper size selections.

<sup>1</sup>Factory default setting.

<sup>2</sup>Displayed only if the LCIT option is installed.

### E.3.4 TRAY SWITCHING

The following values are available on the TRAY SWITCHING submenu of the PostScript protocol menu. This feature is used in conjunction with Section E.3.5.

Feature	Values	Description
TRAY SWITCHING	ON	Enables the TRAY SWITCH SEQ feature allowing paper tray fail-over to occur.
	OFF <sup>1</sup>	Disables the TRAY SWITCH SEQ feature.

<sup>1</sup>Factory default setting.

## E.3 PostScript Submenu

### E.3.5 TRAY SWITCH SEQ

The following values are available on the Tray Switching Sequence (TRAY SWITCH SEQ) submenu of the PostScript protocol menu. The tray switch sequence automatically switches over to the second or third tray. See *DEClaser 3200 Printer Operator's Guide* for more information.

Feature	Values	Description
TRAY SWITCH SEQ	TRAY 1 <sup>1</sup>	Feeds paper from the upper paper cassette.
	TRAY 2	Feeds paper from the lower paper cassette.
	TRAY 3 <sup>2</sup>	Feeds paper from TRAY 3.
	TRAY 1-2	When TRAY 1 is empty, feed paper from TRAY 2.
	TRAY 1-3 <sup>2</sup>	When TRAY 1 is empty, feed paper from TRAY 3.
	TRAY 2-3 <sup>2</sup>	When TRAY 2 is empty, feed paper from TRAY 3.
	TRAY 1-2-3 <sup>2</sup>	When TRAY 1 is empty, feed paper from TRAY 2. When TRAY 2 is empty, feed paper from TRAY 3.

<sup>1</sup>Factory default setting.

<sup>2</sup>Displayed only if the LCIT or MMF option is installed.

### E.3.6 MAN/MMF SIZE

The following values are available on the Manual/Multi-media Feeder (MAN/MMF) submenu of the PostScript protocol menu. Use this feature to set paper size when manual or MMF feeding.

Feature	Values	Description
MAN/MMF SIZE	LETTER <sup>1</sup>	Selects 8.5 in. x 11 in. paper size.
	A4	Selects 210 mm x 297 mm paper size.
	EXECUTIVE	Selects 7~7.5 in. x 10~10.5 in. paper size.
	B5	Selects 176 mm x 250 mm paper size.
	4.125 X 9.5	Selects #10 envelope size.
	DL	Selects 110 mm x 220 mm envelope size.
	3.875 X 7.5	Selects the Monarch envelope size.
	7 X 9	Selects 7 in. x 9 in. paper size.
	HALF LETTER	Selects 8.5 in. x 5.5 in. paper size.
	TWO THIRDS A4	Selects 198 mm x 210 mm paper size.
	C5	Selects 162 mm x 229 mm envelope size.
	A5	Selects 148 mm x 210 mm paper size.
	LEGAL	Selects 8.5 in. x 14 in. paper size.

<sup>1</sup>Factory default setting.

### E.3.7 OUTPUT OFFSET

The following values are available on the OUTPUT OFFSET submenu of the PostScript protocol menu.

Feature	Values	Description
OUTPUT OFFSET	ON	Enables the output tray offset positioning feature to separate print jobs.
	OFF <sup>1</sup>	Disables the output tray offset positioning feature; print jobs will not be separated using offset stacking.

<sup>1</sup>Factory default setting.

## E.3 PostScript Submenu

### E.3.8 WAIT TIMEOUT

The following values are available on the WAIT TIMEOUT submenu of the PostScript protocol menu.

Feature	Values	Description
WAIT TIMEOUT	20 SECONDS	Aborts the print job 20 seconds after receiving the last character.
	40 SECONDS <sup>1</sup>	Aborts the print job 40 seconds after receiving the last character.
	60 SECONDS	Aborts the print job 60 seconds after receiving the last character.
	INFINITE	No time limit after receiving the last character.
	HOST DEFINED	This setting is flagged when the timeout period is set by the PostScript program.

<sup>1</sup>Factory default setting.

### E.3.9 START PAGE

The following values are available on the START PAGE submenu of the PostScript protocol menu.

Feature	Values	Description
START PAGE	ON <sup>1</sup>	The PostScript start page is printed when the printer is turned on.
	OFF	No PostScript start page is printed when the printer is turned on.

<sup>1</sup>Factory default setting.

### E.3.10 JAM RECOVERY

The following values are available on the JAM RECOVERY submenu of the PostScript protocol menu. This feature allows the printer to recover from paper jams without losing data.

Feature	Values	Description
JAM RECOVERY	ON <sup>1</sup>	Allows the printer to recover from paper jams without losing data.
	OFF	No recovery from data loss due to printer jams.

<sup>1</sup>Factory default setting.

### E.3.11 ALLOW JOB RESET

The following values are available on the ALLOW JOB RESET submenu of the PostScript protocol menu. This feature enables you to reset (abort) a print job currently being processed.

Feature	Values	Description
ALLOW JOB RESET	ON <sup>1</sup>	Allows you to abort a print job currently processing from the control panel.
	OFF	Print jobs cannot be aborted.

<sup>1</sup>Factory default setting.

#### Aborting a Print Job

To abort a print job, first press  to place the printer off line. Then press  to abort.

## E.3 PostScript Submenu

### E.3.12 ASYN CTRL MODE

The following values are available on the Asynchronous Control mode (ASYN CTRL MODE) submenu of the PostScript protocol menu. This feature determines how “CTRL C” and “CTRL T” codes are handled. See the *DEClaser 3200 Printer Operator’s Guide* for more information.

Feature	Values	Description
ASYN CTRL MODE	ON <sup>1</sup>	Control codes are handled asynchronously at the communications handler.
	OFF	Control codes are handled synchronously within the data stream.

<sup>1</sup>Factory default setting.

---

# Index

## A

---

Accessories and supplies, A-6  
ADJ CASSETTE feature, 2-11  
Adjustable cassette, 1-10  
Adjustments, 10-1  
    auto scan time, 10-1  
    fuser power saver time, 10-2  
    horizontal registration, 10-3  
    LCIT tray parallelism, 11-10  
    vertical registration, 10-4  
ALARM feature, 2-12  
ALLOW JOB RESET feature, E-21  
ASYN CTRL MODE feature, E-22  
AUTO WRAP feature, E-5

## B

---

Baud rate setting, 2-13

## C

---

Cassettes  
    about, 1-7  
    adjustable, 1-10  
    loading, 1-7, 1-8  
    paper snubbers, 1-8  
Character Dump mode, 2-18  
Cleaning  
    feed roller, 10-5  
    transfer/separation charger, 10-7  
CLEAR PAPER PATH  
    error code lookup table, 6-3  
COMM ERROR feature, 2-14

COMM INTERFACE menu, 2-13  
CONFIG SHEET  
    300K check, C-3  
    printing of, 2-16  
Connector locations, A-8  
Control panel, 2-1  
Control Representation mode  
    *See* Character Dump  
COPIES feature, E-10  
Coprocessor  
    about, 1-14  
    removal and replacement, 9-28  
Customer and Service Menus  
    about, 2-7

## D

---

DC control board  
    IC locations, 5-13  
    page count memory, 9-39  
    16-pin harness, 9-38  
    removal and replacement, 9-34  
DEClaser 3250, 1-14  
DEC PPL3  
    invoking, 3-14  
    Set Up submenus, E-1  
Defaults key, 2-4  
Defaults menu, 2-15  
    save defaults, 2-8  
Developer FIP, 7-21  
DEVICE ID feature, E-6  
DISPLAY LANGUAGE feature, 2-14  
Documentation, related, D-3  
Duplex command set, E-4  
DUPLEX feature

DUPLEX feature (Cont.)

- DEC PPL3, E-3
- LJ2D, E-10
- PostScript, E-16

---

## E

Envelopes

- special considerations, B-4
- specifications, B-3

Erase FIP, 7-20

Error code FIPs, 5-2

Error code master lookup table, 5-3

Error indicator, 2-3

Error LED, 5-11

Expansion memory

- ½-Mb and 2-Mb, 1-14
- See also Memory, 9-30

---

## F

Features

- ADJ CASSETTE, 2-11
- ALARM, 2-12
- ALLOW JOB RESET, E-21
- ASYN CTRL MODE, E-22
- AUTO WRAP, E-5
- COMM ERROR, 2-14
- COMM INTERFACE, 2-13
- COPIES, E-10
- DEVICE ID, E-6
- DISPLAY LANGUAGE, 2-14
- DUPLEX
  - DEC PPL3, E-3
  - LJ2D, E-10
  - PostScript, E-16
- FLOW CONTROL, 2-13
- FONT NUMBER, E-11
- FORM LENGTH, E-12
- JAM RECOVERY PostScript, E-21
- MAN/MMF SIZE, E-19
- MEMORY MANAGEMENT, E-4
- NEW LINE, E-5
- ORIENTATION, E-12
- OUTPUT OFFSET, E-19
- PAPER SIZE, E-11

Features (Cont.)

PAPER TRAY PostScript, E-17

PARITY, 2-13

POWER-UP MESSAGE, E-7

PROTOCOLS, 2-11

START PAGE, E-20

SYMBOL SET, E-13

TRAY SELECTION

- (DEC PPL3), 1-8, E-3
- LJ2D, E-10

TRAY SWITCHING/SWITCH SEQ

- PostScript, E-17

TUMBLE PostScript, E-16

USER PREF SET, E-6

WAIT TIMEOUT, E-20

Feed roller

- cleaning, 10-5
- lower, remove and replace, 9-120
- upper, remove and replace, 9-114

FIP

CLEAR PAPER PATH, 6-3

error code display, 5-2

error code master lookup table, 5-3

fuser fan, 4-5

how to use, xvii

image defects, 7-2

inoperative control panel, 4-6

jams and misfeeds, 6-2

LCIT error code, 11-10

LCIT nonerror code, 11-7

noises, 4-3

printer nonerror code, 4-3

Start, 4-2

Flow control values, 2-13

Font cartridges, 1-14

Font list, 2-18

FONT NUMBER feature, E-11

FORM LENGTH feature, E-12

FRUs

interface cables, A-4

part numbers, RSL, 8-1

removal and replacement of, 9-1, 11-11

Fuser power saver, 10-2

## G

---

Graphic display, 2-2

## H

---

HVPSA

FIP, 7-19

removal and replacement, 9-43

## I

---

Image defects

background staining, 7-3

black and blank prints, 7-5

black lines, 7-18

black spots, 7-16

damaged prints, 7-7

extraneous marks, 7-10

fusing failure, 7-17

light images, 7-11

lookup table, 7-2

registration and skew, 7-12

residual image, 7-16

white bands, 7-8

white spots, 7-10

Indicators

Error, 2-3

Last Page, 2-3, 2-4

Online, 2-3

Supplies, 2-3

Interface cable part numbers, A-4

## J

---

JAM RECOVERY feature PostScript, E-21

## L

---

Labels

special considerations, B-6

specifications, B-5

Laser safety information, 1-1

Last Page indicator, 2-3

LCIT

LCIT (Cont.)

about, 1-14

description, 11-2

error code FIPs, 11-10

nonerror code FIPs, 11-7

LJ2D menu, E-8

Lookup table

CLEAR PAPER PATH, 6-3

error code master, 5-3

image defects, 7-2

## M

---

MAN/MMF SIZE feature, E-19

Memory

organization, 2-8

removal and replacement, 9-30

SIM, 9-30

socket allocation, 9-30

Memory management feature, E-4

Menus

DEC PPL3, E-1

Defaults, 2-15

LJ2D, E-8

PostScript, 1-14, E-14

1948 Service, 3-8

Set Up, 2-9

Test, 2-16

Test Prints, 3-12

Message display, 2-2

## N

---

NEW LINE feature, E-5

NVRAM

changing and selecting values, 2-8, 2-9

saving values, 2-15

## O

---

Off line, Paused, 2-2

Online/Pause key, 2-3

Online indicator, 2-3

Operational status messages, 2-6

ORIENTATION feature, E-12

OUTPUT OFFSET feature, E-19

## P

---

- Page count memory, 9–39
- Paper
  - loading cassettes, 1–7, 1–8
  - special considerations, B–3
  - specifications, B–2
- PAPER SIZE feature, E–11
- PAPER TRAY feature PostScript, E–17
- Parallel serial, 2–13
- PARITY feature, 2–13
- Part numbers
  - accessories and supplies, A–6
  - interface cables, A–4
  - LCIT, 8–4
  - printer, 8–1
- Parts locator, 8–6
- Parts removal and replacement
  - LCIT, 11–11
  - printer, 9–1
- PDL option
  - about, 1–14
  - removal and replacement, 9–27
- PostScript
  - informational messages, 2–6
  - menu, 1–14, E–14
- Power saver, 10–2
  - display message, 2–6
- POWER-UP MESSAGE feature, E–7
- Print drum memory, 5–24
- Printer
  - components, 1–1
  - memory organization, 2–8
  - menus, 2–8
- Printer nonerror code
  - FIPs, 4–3
- Print media, B–2
  - handling and storage of, B–1
- Protocol resident, 2–11

## R

---

- RAM expansion, 9–30
- Recommended spares list (RSL)
  - LCIT, 8–4
  - printer, 8–1
- Refeed paper path, 1–8
- Registration
  - horizontal, 10–3
  - vertical, 10–4
- Related documentation, D–3
- Required training, D–1

## S

---

- Safety information, 1–1
- Saving
  - defaults in NVRAM, 2–15
  - PostScript values, E–14
- Serial parallel, 2–13
- 1948 service menu
  - about, 3–8
  - error log, 3–11
  - SETUP PATTERN, 3–11
- Service shutdown and power-up, 3–14
- Set Up
  - DEC PPL3 submenus, E–1
  - key, 2–2
  - LJ2D submenus, E–8
  - memory, 2–8
  - menu, 2–9
  - PostScript submenus, E–14
- SIM installation, 9–30
- Size-sensing error code, 5–21
- Snubbers, 1–8
- Specifications
  - envelopes, B–3
  - labels, B–5
  - operating, B–6
  - paper, B–2
  - transparencies, B–4
- Start FIP, 4–2
- START PAGE feature, E–20
- Supplies indicator, 2–3

SYMBOL SET feature, E-13

## T

---

Test key, 2-5

Test menu, 2-16

Test prints

error log, 3-11

grid, dark, and light, 3-14

1948 SETUP PATTERN, 3-11

Test Print menu, 3-12

Training, tools, D-1

Transfer/separation charger

cleaning, 10-7

Transparencies

special considerations, B-5

specifications, B-4

Tray parallelism adjustment, 11-10

TRAY SELECTION

about, 1-8

feature (DEC PPL3), 1-8, E-3

feature LJ2D, E-10

TRAY SWITCHING/SWITCH SEQ feature

PostScript, E-17

TUMBLE feature PostScript, E-16

Typographical conventions, xv

## U

---

USER PREF SET feature, E-6

## W

---

WAIT TIMEOUT feature, E-20

Wiring diagram

fuser circuits, 5-28

interlock switch, 5-6

LCIT interface signals, 5-23

left (exit) door sensor, 5-8

main motor, 5-14

offset motor, 5-30

registration sensor and clutch, 6-7

right (feed) door sensor, 5-9

scanner circuit, 5-15

size-sensing switches, 5-21

## X

---

XON/XOFF, 2-13

