

**KMS11-BD/BE  
Synchronous  
Communications  
Processor User Guide**



# KMS11-BD/BE Synchronous Communications Processor User Guide

Prepared by Educational Services  
of  
Digital Equipment Corporation

1st Edition, April 1983

© Digital Equipment Corporation 1983  
All Rights Reserved

The information in this document is subject to change without notice and should not be construed as a commitment by Digital Equipment Corporation. Digital Equipment Corporation assumes no responsibility for any errors that may appear in this document.

Printed in U.S.A.

This document was set on DIGITAL's DECset Integrated Publishing System.

The following are trademarks of Digital Equipment Corporation:

**digital**™

DEC  
DECmate  
DECset  
DECsystem-10  
DECSYSTEM-20  
DECUS

DECwriter  
DIBOL  
KMC  
KMS  
MASSBUS  
PDP  
P/OS  
Professional

Rainbow  
RSTS  
RSX  
UNIBUS  
VAX  
VMS  
VT  
Work Processor

# CONTENTS

Page

## PREFACE

## CHAPTER 1 INTRODUCTION

1.1	INTRODUCTION.....	1-1
1.2	PHYSICAL DESCRIPTION.....	1-1
1.3	FUNCTIONAL DESCRIPTION.....	1-2
1.3.1	KMS11-BD/BE Synchronous Communications Processor.....	1-2
1.3.2	KMC11-B Auxiliary Processor.....	1-2
1.3.3	DMS11-DA Synchronous Line Unit.....	1-2
1.3.4	DM11-BA Modem Control Multiplexer.....	1-2
1.3.5	H317-M Distribution Panel.....	1-3
1.3.6	H317-P Distribution Panel.....	1-3
1.4	GENERAL SPECIFICATIONS.....	1-3
1.4.1	Mechanical Specifications.....	1-3
1.4.2	Operational Environment Specifications.....	1-3
1.4.3	Electrical Specifications.....	1-3
1.4.4	UNIBUS Conductor Specifications.....	1-4

## CHAPTER 2 SITE PREPARATION AND INSTALLATION

2.1	INTRODUCTION.....	2-1
2.2	OPERATING ENVIRONMENT.....	2-1
2.2.1	Physical Elements.....	2-1
2.2.2	Environmental Elements.....	2-2
2.2.3	Grounding Elements.....	2-2
2.3	KMS11-BD/BE COMMUNICATIONS PROCESSOR INSTALLATION.....	2-4
2.3.1	KMC11-B (M8206 - Etch Rev C) UNIBUS Microprocessor.....	2-5
2.3.2	KMC11-B (M8206 - Etch Rev D) UNIBUS Microprocessor.....	2-10
2.3.3	KMC11-B (M8206 - Etch Rev E) UNIBUS Microprocessor.....	2-15
2.3.4	DM11-BA (M8640 - Etch Rev B) Modem Control Multiplexer.....	2-20
2.3.5	DM11-BA (M8640 - Etch Rev C) Modem Control Multiplexer.....	2-25
2.3.6	DMS11-D/DA (M8704) Synchronous Line Unit.....	2-30
2.3.7	DMS11-DA (M8711-YA - Etch Rev A) Eight-Line Synchronous Line Unit.....	2-32
2.3.8	DMS11-DA (M8711-YA - Etch Rev B) Eight-Line Synchronous Line Unit.....	2-34

## CHAPTER 3 SYSTEM CONFIGURATION

3.1	INTRODUCTION.....	3-1
3.2	SYSTEM CONFIGURATION.....	3-1
3.3	SYSTEM CABLING.....	3-4
3.3.1	DM11-BA (M8640) Multiplexer Cabling to an H317-M Distribution Panel.....	3-4

## CONTENTS (Cont)

		Page
3.3.2	DMS11-DA (M8704) Line Unit Cabling to an H317-M Distribution Panel.....	3-5
3.3.3	DMS11-DA (M8711-YA) Line Unit Cabling to an H317-M Distribution Panel.....	3-6
3.3.4	DM11-BA (M8640) Multiplexer Cabling to an H317-P Distribution Panel.....	3-7
3.3.5	DMS11-DA (M8704) Line Unit Cabling to an H317-P Distribution Panel.....	3-8
3.3.6	DMS11-DA (M8711-YA) Line Unit Cabling to an H317-P Distribution Panel.....	3-9
<b>CHAPTER 4</b>	<b>MAINTENANCE</b>	
4.1	INTRODUCTION.....	4-1
4.2	MAINTENANCE PHILOSOPHY.....	4-1
4.3	SPECIAL TOOLS AND EQUIPMENT.....	4-1
4.4	PDP-11 SYSTEM DIAGNOSTIC SOFTWARE.....	4-1
4.4.1	CZKMB (YM-Z093D-A).....	4-2
4.4.2	CZKMC (YM-Z093D-B).....	4-2
4.4.3	CZKMD (YM-Z136D-1).....	4-2
4.4.4	CZKME (YM-Z136D-2).....	4-3
4.4.5	CZKMG (YM-Z138D-A).....	4-3
4.4.6	CZKMF (YM-Z136D-3).....	4-4
4.4.7	CXKMA (YM-A093D-X).....	4-4
4.4.8	CXDMS (YM-Z138D-X).....	4-4
4.5	PDP-11 SYSTEM DIAGNOSTIC LISTINGS.....	4-5
4.6	VAX-11 SYSTEM DIAGNOSTIC SOFTWARE.....	4-5
4.6.1	ZZ-EVDHA.....	4-5
4.6.2	ZZ-EVDKA.....	4-6
4.6.3	ZZ-EVDJA.....	4-6
4.6.4	ZZ-EVDIA.....	4-7
4.6.5	ZZ-EVDHB.....	4-7
4.6.6	ZZ-EVDIB.....	4-7
4.7	VAX-11 SYSTEM DIAGNOSTIC LISTINGS.....	4-8
<b>CHAPTER 5</b>	<b>FIELD REPLACABLE UNITS</b>	
5.1	INTRODUCTION.....	5-1
5.2	BOARDS.....	5-1
5.3	TEST CONNECTORS.....	5-1
5.4	CABLES.....	5-1
5.5	ASSEMBLIES.....	5-2

## FIGURES

Figure No.	Title	Page
2-1	H317-M Distribution Panel Jumpers.....	2-3
2-2	H317-P Distribution Panel Jumpers.....	2-4

## FIGURES (Cont)

Figure No.	Title	Page
2-3	KMC11-B (M8206 - Etch Rev C) UNIBUS Microprocessor Board .....	2-5
2-4	KMC11-B (M8206 - Etch Rev C) UNIBUS Microprocessor Address Selection Switch E125 .....	2-6
2-5	KMC11-B (M8206 - Etch Rev C) UNIBUS Microprocessor Vector Selection Switch E27 .....	2-7
2-6	DD11-DK Nine-Slot Backplane with KMS11-BD/BE Communications Processor Board Locations (Viewed from the Backplane Pin-Side) .....	2-9
2-7	KMC11-B (M8206 - Etch Rev D) UNIBUS Microprocessor Board .....	2-10
2-8	KMC11-B (M8206 - Etch Rev D) UNIBUS Microprocessor Vector Selection Switch E129 .....	2-10
2-9	KMC11-B (M8206 - Etch Rev D) UNIBUS Microprocessor Vector Selection Switch E31 .....	2-12
2-10	DD11-DK Nine-Slot Backplane with KMS11-BD/BE Communications Processor Board Locations (Viewed from the Backplane Pin-Side) .....	2-14
2-11	KMC11-B (M8206 - Etch Rev E) UNIBUS Microprocessor Board .....	2-15
2-12	KMC11-B (M8206 - Etch Rev E) UNIBUS Microprocessor Address Selection Switch E129 .....	2-15
2-13	KMC11-B (M8206 - Etch Rev E) UNIBUS Microprocessor Vector Selection Switch E31 .....	2-17
2-14	KMC11-B (M8206 - Etch Rev E) UNIBUS Microprocessor Programmer Timer Selection Switch E82 .....	2-18
2-15	DD11-DK Nine-Slot Backplane with KMS11-BD/BE Communications Processor Board Locations (Viewed from the Backplane Pin-Side) .....	2-19
2-16	DM11-BA (M8640 - Etch Rev B) Modem Control Multiplexer Board .....	2-20
2-17	DM11-BA (M8640 - Etch Rev B) Modem Control Multiplexer Address Selection Switch E108 .....	2-21
2-18	DM11-BA (M8640 - Etch Rev B) Modem Control Multiplexer Vector Selection Switch E84 .....	2-22
2-19	DD11-DK Nine-Slot Backplane with KMS11-BD/BE Communications Processor Board Locations (Viewed from the Backplane Pin-Side) .....	2-24
2-20	DM11-BA (M8640 - Etch Rev C) Modem Control Multiplexer Board .....	2-25
2-21	DM11-BA (M8640 - Etch Rev C) Modem Control Multiplexer Address Selection Switch E65 .....	2-25
2-22	DM11-BA (M8640 - Etch Rev C) Modem Control Multiplexer Vector Selection Switch E49 .....	2-27
2-23	DM11-BA (M8640 - Etch Rev C) Modem Control Multiplexer Switchpack E66 .....	2-28
2-24	DD11-DK Nine Slot Backplane with KMS11-BD/BE Communications Processor Board Locations (Viewed from the Backplane Pin-Side) .....	2-29
2-25	DMS11-D/DA (M8704) Synchronous Line Unit Board .....	2-30
2-26	DMS11-D/DA (M8704) Synchronous Line Unit Typical Switchpack .....	2-30
2-27	DD11-DK Nine-Slot Backplane with KMS11-BD/BE Communications Processor Board Locations (Viewed from the Backplane Pin-Side) .....	2-31
2-28	DMS11-DA (M8711-YA - Etch Rev A) Eight-Line Synchronous Line Unit Board .....	2-32
2-29	DD11-DK Nine-Slot Backplane with KMS11-BD/BE Communications Processor Board Locations (Viewed from the Backplane Pin-Side) .....	2-33
2-30	DMS11-DA (M8711-YA - Etch Rev B) Eight-Line Synchronous Line Unit Board .....	2-34

## FIGURES (Cont)

Figure No.	Title	Page
2-31	DD11-DK Nine-Slot Backplane with KMS11-BD/BE Communications Processor Board Locations (Viewed from the Backplane Pin-Side).....	2-35
3-1	KMS11-BD/BE Communications Processor UNIBUS Connector Interface.....	3-2
3-2	DD11-DK Nine-Slot Backplane (Viewed from the Backplane Pin-Side).....	3-3
3-3	DM11-BA (M8640) Multiplexer to H317-M Distribution Panel Cabling.....	3-4
3-4	DMS11-DA (M8704) Line Unit to H317-M Distribution Panel Cabling.....	3-5
3-5	DMS11-DA (M8711-YA) Line Unit to H317-M Distribution Panel Cabling.....	3-6
3-6	DM11-BA (M8640) Multiplexer to H317-P Distribution Panel Cabling.....	3-7
3-7	DMS11-DA (M8704) Line Unit to H317-P Distribution Panel Cabling.....	3-8
3-8	DMS11-DA (M8711-YA) Line Unit to H317-P Distribution Panel Cabling.....	3-9

## TABLES

Table No.	Title	Page
2-1	KMC11-B (M8206 - Etch Rev C) UNIBUS Microprocessor Address Selection Switch E125 Settings.....	2-6
2-2	KMC11-B (M8206 - Etch Rev C) UNIBUS Microprocessor Vector Selection Switch E27 Settings.....	2-8
2-3	KMC11-B (M8206 - Etch Rev D) UNIBUS Microprocessor Address Selection Switch E129 Settings.....	2-11
2-4	KMC11-B (M8206 - Etch Rev D) UNIBUS Microprocessor Vector Selection Switch E31 Settings.....	2-13
2-5	KMC11-B (M8206 - Etch Rev E) UNIBUS Microprocessor Address Selection Switch E129 Settings.....	2-16
2-6	KMC11-B (M8206 - Etch Rev E) UNIBUS Microprocessor Vector Selection Switch E31 Settings.....	2-17
2-7	DM11-BA (M8640 - Etch Rev B) Modem Control Multiplexer Address Selection Jumper (W1) and Switch (E108) Settings.....	2-21
2-8	DM11-BA (M8640 - Etch Rev B) Modem Control Multiplexer Vector Selection Switch E84 Settings.....	2-23
2-9	DM11-BA (M8640 - Etch Rev C) Modem Control Multiplexer Address Selection Switches E49-8 and E65 Settings.....	2-26
2-10	DM11-BA (M8640 - Etch Rev C) Modem Control Multiplexer Vector Selection Switch E49 Settings.....	2-28
2-11	DM11-BA (M8640 - Etch Rev C) Modem Control Multiplexer Switchpack E66 Settings.....	2-29
2-12	DMS11-D/DA M8704 Synchronous Line Unit Switchpack R1, E4, E10, and E25 Settings.....	2-30
4-1	PDP-11 System Diagnostics.....	4-5
4-2	VAX-11 System Diagnostics.....	4-8

## PREFACE

The *KMS11-BD/BE Synchronous Communications Processor User Guide* contains technical information that gives the user a basic description of the specifications and features of the KMS11-BD/BE communications processor.

Information about specific units contained in the KMS11-BD/BE communications processor can be found in the manuals listed below:

- *KMS11-BD/BE Synchronous Communications Processor* (YM-C174C-00)
- *VAX-11/780 System Installation Manual* (EK-S1789-IN)
- *VAX-11/780 Diagnostic User Guide* (EK-DS780-UG)
- *DM11-BA Modem Control Multiplexer* (YM-C138C-00)
- *KMC11-B UNIBUS Microprocessor* (YM-C093C-00)
- *DMS11-D/DA Synchronous Line Unit* (YM-C186C-00)
- *KMC11 Microprocessor User Manual* (EK-KMC11B-UG)
- *KMC11-B Programmer's Manual* (YM-P093C-00)
- *PDP-11 Peripherals Handbook* (EB-15460-20)
- *PDP-11 Peripherals Handbook* (EB-17560-20)
- *Terminals and Communications Handbook - 1979* (EB-15486-20)
- *Terminals and Communications Handbook - 1980* (EB-18251-20)
- *KMS11 Synchronous Communications Processor Pocket Service Guide* (EK-KMS11-PS)
- *I/O Bulkhead Engineering Specification* (EK-IOBES-DG)



## CHAPTER 1 INTRODUCTION

### 1.1 INTRODUCTION

This chapter gives a physical description, functional description, and the general specifications of the KMS11-BD/BE synchronous communications processor that is used on systems that have a UNIBUS conductor.

### 1.2 PHYSICAL DESCRIPTION

The KMS11-BD synchronous communications processor consists of the following:

- One (1) KMC11-B (M8206) general purpose UNIBUS microprocessor.
- One (1) DMS11-DA (M8704 or M8711-YA) eight-line synchronous line unit.
- One (1) DM11-BA (M8640) modem control multiplexer.
- One (1) H317-M distribution panel or one (1) H317-P distribution panel.
- Eight (8) H3256 H317-M test connectors.
- One (1) BC08R-01 cable.
- Two (2) BC11W-10 50-conductor unshielded cables.
- Two (2) 2ME044A or 5414698 DMS11-DA test connectors.
- Two (2) 2ME122A or 5414700 DM11-BA test connectors.
- Two (2) BC08R-10 cables
- Ten (10) 3611567 "This side up" labels.
- One (1) DD11-DK nine-slot backplane.
- Two (2) 1215278 protector cables.

The KMS11-BE synchronous communications processor consists of the following:

- One (1) KMC11-B (M8206) general purpose UNIBUS microprocessor.
- One (1) DMS11-DA (M8704 or M8711-YA) eight-line synchronous line unit.
- One (1) DM11-BA (M8640) modem control multiplexer.
- One (1) H317-M distribution panel or one (1) H317-P distribution panel.

- Eight (8) H3256 H317-M test connectors.
- One (1) BC08R-01 cable.
- Two (2) BC11W-10 50-conductor unshielded cables.
- Two (2) 2MF044A or 5414698 DMS11-DA test connectors.
- Two (2) 2ME122A or 5414700 DM11-BA test connectors.
- Two (2) BC08R-10 cables.
- Ten (10) 3611567 "This side up" labels.
- Three (3) 1215278 module protectors.

Each module that makes up the KMS11-BD/BE is a hex-height module that plugs into a nine-slot backplane.

### 1.3 FUNCTIONAL DESCRIPTION

The KMS11-BD/BE synchronous communications processor is a complex, high-speed microprocessor which can be used to implement custom networking applications. The KMS11-BD/BE communications processor provides high-speed, efficient communications between the processor and up to eight serial synchronous lines.

#### 1.3.1 KMS11-BD/BE Synchronous Communications Processor

The KMS11-BD/BE communications processor can be used to establish a communications link in a variety of different applications ranging from terminal cluster controller support to full interconnection between remote operating systems, application programs, and peripheral devices. The KMS11-BD/BE communications processor is particularly suited for use in fully connected and star type topologies where the requirements for multiple line connections exist.

#### 1.3.2 KMC11-B Auxiliary Processor

The KMC11-B auxiliary processor provides the UNIBUS interface and connection to the line termination unit. This microprocessor controls I/O operations of the synchronous line units that require extensive intelligence, such as data communications and analog I/O.

#### 1.3.3 DMS11-DA Synchronous Line Unit

The DMS11-DA synchronous line unit contains eight individual interface circuits that take care of the serial-to-parallel and parallel-to-serial conversion of the data. The interface circuits also verify that bit shifting and flag and frame checking sequences are performed properly.

#### 1.3.4 DM11-BA Modem Control Multiplexer

The DM11-BA modem control multiplexer provides a separate UNIBUS conductor interface for the modem control signals required to operate synchronous lines. The DM11-BA multiplexer can be controlled by either host software or KMC11-B auxiliary processor firmware.

When the modem control multiplexer is controlled by the KMC11-B auxiliary processor, interrupts from the DM11-BA multiplexer to the host are disabled, and the KMC11-B auxiliary processor reads and writes modem control registers. The auxiliary processor polls the modem control multiplexer looking for transitions in modem control lines, and initiates modem action when these transitions take place.

When the modem control multiplexer is not controlled by the auxiliary processor, interrupts from the multiplexer to the host are enabled, and the host controls the modem control registers. When transitions in the modem control lines occur, the modem action is then automatically controlled by the host.

### 1.3.5 H317-M Distribution Panel

The H317-M distribution panel combines the modem control signals, data from the modem control unit, and line termination units into a single, unified set for each of the eight lines. Jumpers on the distribution panel provide a means to set up individual modem control configurations. All interface signals are EIA RS-232-C/CCITT V.24 and V.28 compatible.

### 1.3.6 H317-P Distribution Panel

The H317-P distribution panel combines the modem control signals, data from the modem control unit, and line termination units into a single, unified set for each of the eight lines while maintaining strict electromagnetic interference (EMI) shielding integrity. This distribution panel is downward compatible with the H317-M distribution panel. The H317-P is made up of two parts, the I/O panel modules (7019648-01) and the I/O panel frame (7426409-01).

## 1.4 GENERAL SPECIFICATIONS

General specifications for the KMS11-BD/BE communications processor are broken into the following categories:

- Mechanical specifications,
- Operational environment specifications,
- Electrical specifications, and
- UNIBUS conductor specifications.

### 1.4.1 Mechanical Specifications

Mounting Requirements:	Space for a DD11-DK type nine-slot system unit.
H317-M Distribution Panel:	13.12 cm × 47.50 cm (5.25 in × 19.00 in) of rack space.
H317-P Distribution Panel:	13.12 cm × 47.50 cm (5.25 in × 19.00 in) of rack space.

### 1.4.2 Operational Environment Specifications

Temperature:	10°C to 40°C (50°F to 104°F)
Relative Humidity:	10% to 90%
Maximum Wet Bulb:	28°C (82°F)
Minimum Dew Point:	2°C (36°F)

### 1.4.3 Electrical Specifications

Logic:	Transistor-transistor logic (TTL)
Interface Levels:	RS-232-C, RS-423-A, and MIL-188-114 unbalanced
Power (Maximum):	+5 Vdc @ 12.5 A +15 Vdc @ 1.5 A -15 Vdc @ 0.5 A

#### 1.4.4 UNIBUS Conductor Specifications

UNIBUS Conductor Loads	7 ac unit loads 2 dc unit loads
Addresses	KMC11-B auxiliary processor: 760016 to 760016 (typical) DM11-BA modem control multiplexer: 760020 to 760022 (typical)
Vectors	KMC11-B auxiliary processor: 300, 304 (typical) DM11-BA modem control multiplexer: 310 (typical)
Interrupt Levels	KMC11-B auxiliary processor: BR5, NPR DM11-BA modem control multiplexer: BR4

#### NOTE

Addresses and vectors are switch selectable within the floating or user address and vector space. (For switchpack settings, refer to Chapter 2.)

## CHAPTER 2 SITE PREPARATION AND INSTALLATION

### 2.1 INTRODUCTION

This chapter describes the installation, setup, and configuration for the KMS11-BD/BE synchronous communications processor. It also describes the various revision levels for the KMS11-BD/BE communications processor.

### 2.2 OPERATING ENVIRONMENT

The operating environment of the KMS11-BD/BE synchronous communications processor is made up of three elements. These elements are as follows:

- Physical elements (Section 2.2.1)
- Environmental elements (Section 2.2.2)
- Grounding elements (Section 2.2.3)

#### 2.2.1 Physical Elements

The KMS11-BD/BE communications processor requires adequate space for mounting the following:

- BA11-K nine-slot expander box

#### CAUTION

**To ensure proper air circulation for cooling purposes, one blank slot must be left between each board when placed in the DD11-DK backplane. (Refer to Figure 3-2 for proper module placement.)**

- Either the H317-M distribution panel, or the H317-P distribution panel.

#### BA11-K Expander Box

The expander box requires a 63.5 cm × 45.7 cm × 26.7 cm (25.0 in × 18.0 in × 10.5 in) area to enable proper mounting within the cabinet.

#### H317-M Distribution Panel

The H317-M distribution panel requires a 13.30 cm × 48.30 cm (5.25 in × 19.00 in) area for rack mounting. The H317-M distribution panel must be mounted within 3.3 m (10.0 ft) of the BA11-K expander box.

#### H317-P Distribution Panel

The H317-P distribution panel requires a 13.30 cm × 48.30 cm (5.25 in × 19.00 in) area for rack mounting. The H317-P distribution panel must be mounted within 3.3 m (10.0 ft) of the BA11-K expander box.

### 2.2.2 Environmental Elements

The KMS11-BD/BE communications processor is designed to operate in a "Class B" environment. A "Class B" environment meets the following prerequisites:

- Temperature - 10°C to 40°C (50°F to 104°F)
- Relative Humidity - 10% to 90%
- Maximum Wet Bulb - 28°C (82°F)
- Minimum Dew Point - 2°C (36°F)

### 2.2.3 Grounding Elements

Careful grounding is essential in order to avoid ground loops and poor noise rejection. To eliminate ground loops and to have proper noise rejection, ensure that:

- The KMS11-BD/BE processor and all equipment that it connects to shares a common ac power source.
- No electrically noisy equipment shares the same power source.
- The earth ground of the KMS11-BD/BE processor and all modem earth grounds are common.

#### H317-M Grounding

The normal grounding system used on the H317-M distribution panel (Figure 2-1), J1 through J8, is as follows:

- Pin 1 (EIA protective ground) is connected directly to the circuit/frame ground.
- Pin 7 (EIA signal ground) is connected directly to circuit/frame ground.

#### H317-M Jumpers

After the H317-M distribution panel is physically installed, ensure that the W10, W12, W14, W16, W20, W22, and W24 ground jumpers are installed. (Refer to Figure 2-1 for jumper locations.)

#### NOTE

**Jumpers W1 through W8 must be installed in order to run the KMS11-BD/BE processor diagnostics.**

#### H317-P Grounding

The H317-P distribution panel (Figure 2-2) is shipped with jumpers W2, W4, W6, and W8 installed on each I/O panel module. This connects pin 1 of each EIA connector to the KMS-11 processor circuit ground.

#### NOTE

**If jumpers W2, W4, W6, and W8 are removed, and W1, W3, W5, and W7 are inserted, pin 1 of each EIA connector is electrically connected to chassis (frame) ground.**

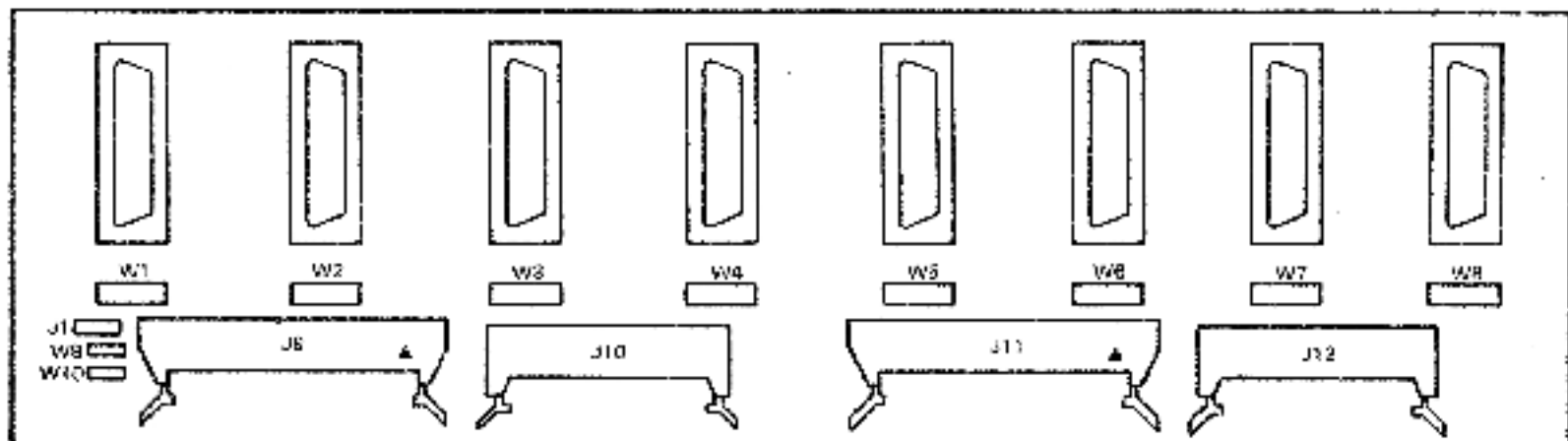

196-3321

Figure 2-1 H317-M Distribution Panel Jumpers

### H317-P Switch Settings

The switchpack (Figure 2-2) on each I/O panel module controls the transmission of the maintenance clock that is generated by the KMS-11 communications processor. These switches must be ON to run KMS-11 communications processor diagnostics. The switch numbers on each switchpack correspond to the line member on that module.

#### NOTE

If these switches are OFF, the diagnostics will fail immediately since the maintenance clock is required for the diagnostics to run.

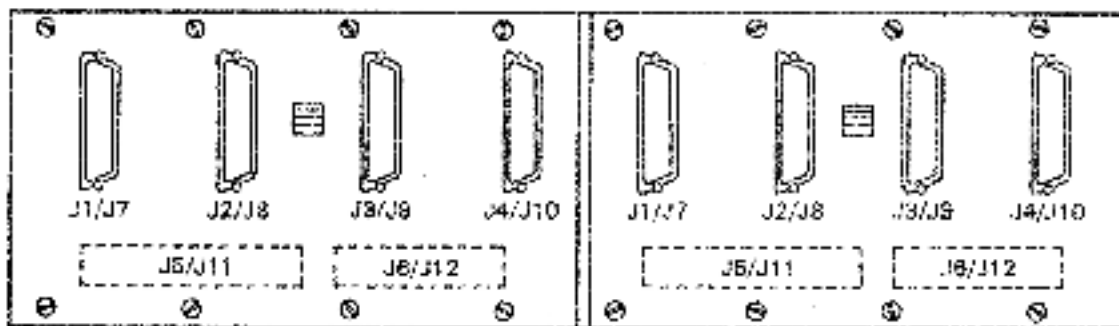

MG-4715

Figure 2-2 H317-P Distribution Panel Jumpers

### 2.3 KMS11-BD/BE COMMUNICATIONS PROCESSOR INSTALLATION

This section covers the installation and setup of the KMS11-BD/BE communications processor for the various revision levels. The boards are listed numerically by the printed circuit board part numbers and revision levels. Following the printed circuit board number, the option nomenclature is listed. For example:

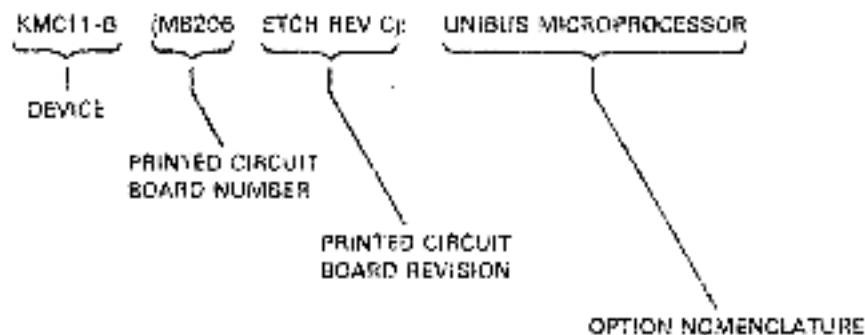

MG-4716

### 2.3.1 KMC11-B (M8206 - Etch Rev C) UNIBUS Microprocessor

To install the KMC11-B (M8206 - Etch Rev C) general purpose UNIBUS microprocessor, perform the following:

1. Ensure that the priority plug (level 5) is properly inserted into its socket.
2. Ensure that jumper W1 (Figure 2-3) is installed.

#### NOTE

**Jumper W1 should not be removed. It is removed only during module testing at the factory.**

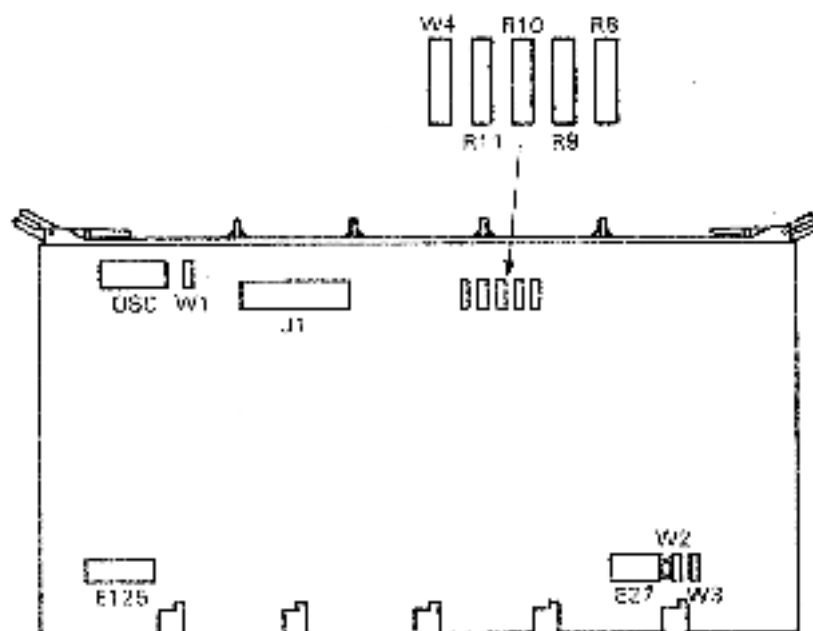

E27 = ADDRESS SELECT (10-POSITION SWITCH)  
E126 = VECTOR SELECT (7-POSITION SWITCH)

#### NOTE

E27 MAY BE 10 POSITIONS. IF SO E27-0 REPLACES W2 AND  
E27-10 REPLACES W3.

W1 = ALWAYS IN  
W2 = ALWAYS IN  
W3 = NORMALLY IN (ALLOWS KMC11-B MICROPROCESSOR CONTROL OF AC LG)  
W4 = ALWAYS IN (ECO NU006)

W1-10012

Figure 2-3 KMC11-B (M8206 - Etch Rev C) UNIBUS Microprocessor Board

3. Set the E125 switchpack switches (Figure 2-4) so that the module will respond to its assigned address. (Refer to Table 2-1 for address switch settings.)

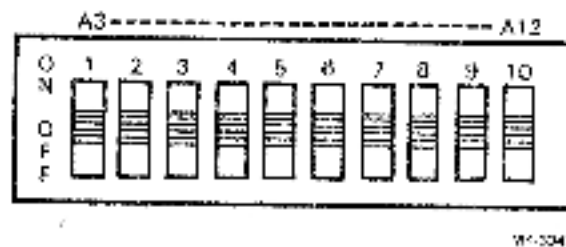

Figure 2-4 KMC11-B (M8206) - Etch Rev C) UNIBUS Microprocessor Address Selection Switch E125

Table 2-1 KMC11-B (M8206 - Etch Rev C) UNIBUS Microprocessor Address Selection Switch E125 Settings

Address	E125 Switch Settings									
	S1 (A3)	S2 (A4)	S3 (A5)	S4 (A6)	S5 (A7)	S6 (A8)	S7 (A9)	S8 (A10)	S9 (A11)	S10 (A12)
760000	ON	ON	ON	ON	ON	ON	ON	ON	ON	ON
760010	OFF	ON	ON	ON	ON	ON	ON	ON	ON	ON
760020	ON	OFF	ON	ON	ON	ON	ON	ON	ON	ON
760030	OFF	OFF	ON	ON	ON	ON	ON	ON	ON	ON
760040	ON	ON	OFF	ON	ON	ON	ON	ON	ON	ON
760050	OFF	ON	OFF	ON	ON	ON	ON	ON	ON	ON
760060	ON	OFF	OFF	ON	ON	ON	ON	ON	ON	ON
760070	OFF	OFF	OFF	ON	ON	ON	ON	ON	ON	ON
760100	ON	ON	ON	OFF	ON	ON	ON	ON	ON	ON
760200	ON	ON	ON	ON	OFF	ON	ON	ON	ON	ON
760300	ON	ON	ON	OFF	OFF	ON	ON	ON	ON	ON
760400	ON	ON	ON	ON	ON	OFF	ON	ON	ON	ON
760500	ON	ON	ON	OFF	ON	OFF	ON	ON	ON	ON
760600	ON	ON	ON	ON	OFF	OFF	ON	ON	ON	ON
760700	ON	ON	ON	OFF	OFF	OFF	ON	ON	ON	ON

**Table 2-1 KMC11-B (M8206 – Etc Rev C) UNIBUS Microprocessor  
Address Selection Switch E125 Settings (Cont)**

Address	E125 Switch Settings									
	S1 (A3)	S2 (A4)	S3 (A5)	S4 (A6)	S5 (A7)	S6 (A8)	S7 (A9)	S8 (A10)	S9 (A11)	S10 (A12)
761000	ON	ON	ON	ON	ON	ON	OFF	ON	ON	ON
762000	ON	ON	ON	ON	ON	ON	ON	OFF	ON	ON
763000	ON	ON	ON	ON	ON	ON	OFF	OFF	ON	ON
764000	ON	ON	ON	ON	ON	ON	ON	ON	OFF	ON
765000	ON	ON	ON	ON	ON	ON	OFF	ON	OFF	ON
766000	ON	ON	ON	ON	ON	ON	ON	OFF	OFF	ON
767000	ON	ON	ON	ON	ON	ON	OFF	OFF	OFF	ON
770000	ON	ON	ON	ON	ON	ON	ON	ON	ON	OFF
777770	OFF	OFF	OFF	OFF	OFF	OFF	OFF	OFF	OFF	OFF

4. Set the E27 switchpack switches (Figure 2-5) to the proper vector selection. (Refer to Table 2-2 for vector switch settings.)

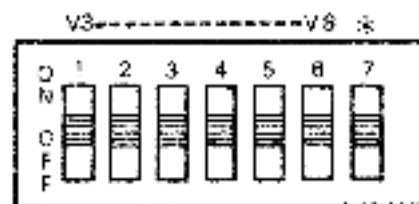

\* S7 NOT USED

M6-0246

**Figure 2-5 KMC11-B (M8206 – Etc Rev C) UNIBUS  
Microprocessor Vector Selection Switch E27**

**Table 2-2 KMC11-B (M8206 - Etch Rev C) UNIBUS Microprocessor  
Vector Selection Switch E27 Settings**

Vector	E31 Switch Settings						
	S1 (V3)	S2 (V4)	S3 (V5)	S4 (V6)	S5 (V7)	S6 (V8)	S7 (Not Used)
300	OFF	OFF	OFF	ON	ON	OFF	
310	ON	OFF	OFF	ON	ON	OFF	
320	OFF	ON	OFF	ON	ON	OFF	
330	ON	ON	OFF	ON	ON	OFF	
340	OFF	OFF	ON	ON	ON	OFF	
350	ON	OFF	ON	ON	ON	OFF	
360	OFF	ON	ON	ON	ON	OFF	
370	ON	ON	ON	ON	ON	OFF	
400	OFF	OFF	OFF	OFF	OFF	ON	
500	OFF	OFF	OFF	ON	OFF	ON	
600	OFF	OFF	OFF	OFF	ON	ON	
700	OFF	OFF	OFF	ON	ON	ON	

5. Ensure that jumper W2 (Figure 2-3) is installed at all times.

**NOTE**

**Jumper W2 should not be removed. It is removed only during module testing at the factory.**

6. Ensure that jumper W3 (Figures 2-3) is installed.

**NOTE**

**Jumper W3 should only be removed if the KMC11-B microprocessor control of AC LO is inhibited.**

- Install the MB206 (Etch Rev C) in the appropriate location in the DD11-DK nine-slot backplane (Figure 2-6).

**NOTE**

Ensure that the nonprocessor request (NPR) grant continuity wire between pins CA1 and CB1 of the backplane is removed from the location in which the MB206 is being installed.

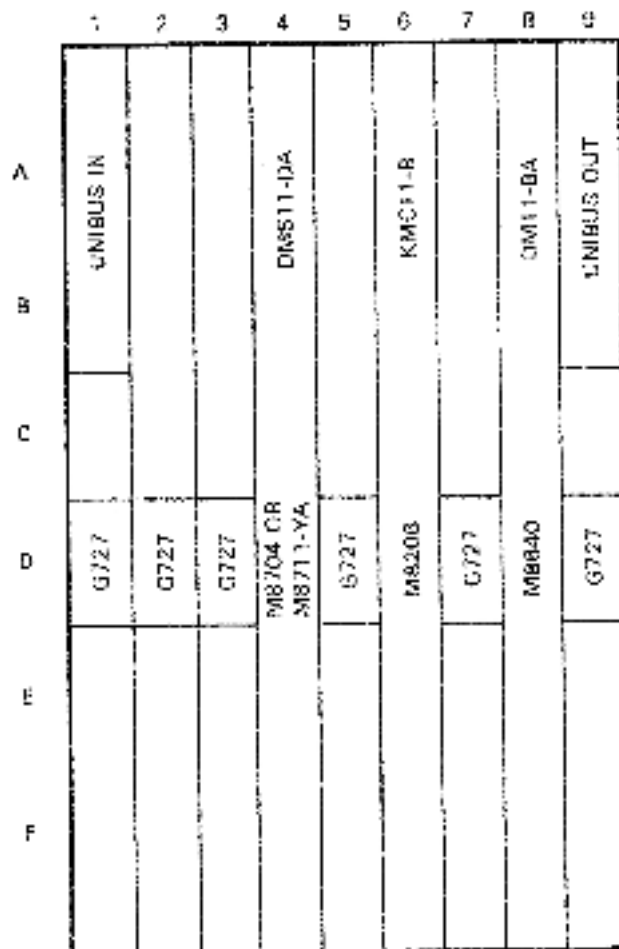

NK-2232

Figure 2-6 DD11-DK Nine-Slot Backplane with KMS11-BD/BE Communications Processor Board Locations (Viewed from the Backplane Pin-Side)

### 2.3.2 KMC11-B (M8206 - Etch Rev D) UNIBUS Microprocessor

To install the KMC11-B (M8206 - Etch Rev D) UNIBUS microprocessor, perform the following:

1. Ensure that the priority plug (level 5) is properly inserted into its socket.
2. Ensure that jumper W1 (Figure 2-7) is installed.

#### NOTE

Jumper W1 should not be removed. It is removed only during module testing at the factory.

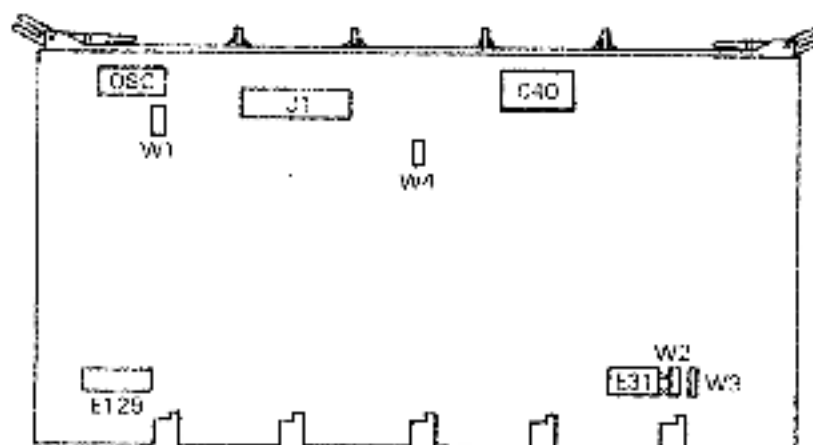

E31 = VECTOR SELECT (7-POSITION SWITCH)  
E129 = ADDRESS SELECT (10-POSITION SWITCH)

#### NOTE

E31 MAY BE 10 POSITIONS. IF SO E31-8  
REPLACES W2 AND E31-10 REPLACES W3.

W1 = ALWAYS IN

W2 = ALWAYS IN

W3 = NORMALLY IN (ALLOWS KMC11-B MICROPROCESSOR CONTROL OF AC LO)

W4 = ALWAYS IN (ECO NL006)

C40 = AT PRESENT THE TIMER VALUES REQUIRED FOR  
KNOWN SOFTWARE IS AS FOLLOWS:

• ODCMP (CSS)	EITHER
• X.26 (CSS)	115 MS
• ADDCP (CSS)	115 MS
• BX.2E (BFLU)	75 $\mu$ s

#### NOTE

WHEN C40 = 10  $\mu$ i 20 V, TIMEOUT = 115 MS

WHEN C40 = 4700 pF 100 V, TIMEOUT = 75  $\mu$ s

M8206

Figure 2-7 KMC11-B (M8206 - Etch Rev D) UNIBUS Microprocessor Board

3. Set the E129 switchpack switches (Figure 2-8) so that the module will respond to its assigned address. (Refer to Table 2-3 for address switch settings.)

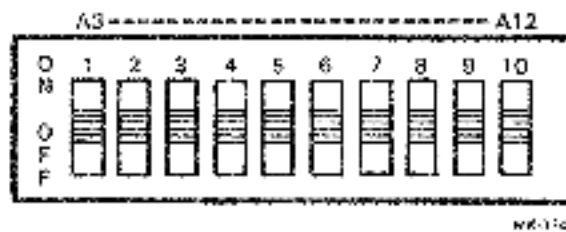

Figure 2-8 KMC11-B (M8206 - Etch Rev D) UNIBUS Microprocessor Address Selection Switch E129

Table 2-3 KMC11-B (M8206 - Etch Rev D) UNIBUS Microprocessor Address Selection Switch E129 Settings

Address	E129 Switch Settings									
	S1 (A3)	S2 (A4)	S3 (A5)	S4 (A6)	S5 (A7)	S6 (A8)	S7 (A9)	S8 (A10)	S9 (A11)	S10 (A12)
760000	ON	ON	ON	ON	ON	ON	ON	ON	ON	ON
760010	OFF	ON	ON	ON	ON	ON	ON	ON	ON	ON
760020	ON	OFF	ON	ON	ON	ON	ON	ON	ON	ON
760030	OFF	OFF	ON	ON	ON	ON	ON	ON	ON	ON
760040	ON	ON	OFF	ON	ON	ON	ON	ON	ON	ON
760050	OFF	ON	OFF	ON	ON	ON	ON	ON	ON	ON
760060	ON	OFF	OFF	ON	ON	ON	ON	ON	ON	ON
760070	OFF	OFF	OFF	ON	ON	ON	ON	ON	ON	ON
760100	ON	ON	ON	OFF	ON	ON	ON	ON	ON	ON
760200	ON	ON	ON	ON	OFF	ON	ON	ON	ON	ON
760300	ON	ON	ON	OFF	OFF	ON	ON	ON	ON	ON
760400	ON	ON	ON	ON	ON	OFF	ON	ON	ON	ON
760500	ON	ON	ON	OFF	ON	OFF	ON	ON	ON	ON
760600	ON	ON	ON	ON	OFF	OFF	ON	ON	ON	ON
760700	ON	ON	ON	OFF	OFF	OFF	ON	ON	ON	ON

Table 2-3 KMC11-B (M8206 – Etch Rev D) UNIBUS Microprocessor  
Address Selection Switch E129 Settings

Address	E129 Switch Settings									
	S1 (A3)	S2 (A4)	S3 (A5)	S4 (A6)	S5 (A7)	S6 (A8)	S7 (A9)	S8 (A10)	S9 (A11)	S10 (A12)
761000	ON	ON	ON	ON	ON	ON	OFF	ON	ON	ON
762000	ON	ON	ON	ON	ON	ON	ON	OFF	ON	ON
763000	ON	ON	ON	ON	ON	ON	OFF	OFF	ON	ON
764000	ON	ON	ON	ON	ON	ON	ON	ON	OFF	ON
765000	ON	ON	ON	ON	ON	ON	OFF	ON	OFF	ON
766000	ON	ON	ON	ON	ON	ON	ON	OFF	OFF	ON
767000	ON	ON	ON	ON	ON	ON	OFF	OFF	OFF	ON
770000	ON	ON	ON	ON	ON	ON	ON	ON	ON	OFF
777770	OFF	OFF	OFF	OFF	OFF	OFF	OFF	OFF	OFF	OFF

4. Set the E31 switchpack switches (Figure 2-9) to the proper vector selection. (Refer to Table 2-4 for vector switch settings.)

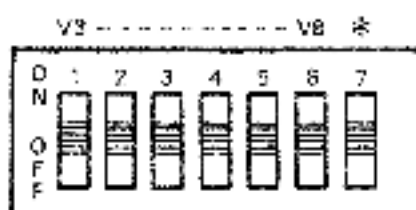

\* S7 NOT USED

NK1201

Figure 2-9 KMC11-B (M8206 – Etch Rev D) UNIBUS  
Microprocessor Vector Selection Switch E31

**Table 2-4 KMC11-B (M8206 - Etch Rev D) UNIBUS Microprocessor  
Vector Selection Switch E31 Settings**

Vector	E31 Switch Settings						
	S1 (V3)	S2 (V4)	S3 (V5)	S4 (V6)	S5 (V7)	S6 (V8)	S7 (Not Used)
300	OFF	OFF	OFF	ON	ON	OFF	
310	ON	OFF	OFF	ON	ON	OFF	
320	OFF	ON	OFF	ON	ON	OFF	
330	ON	ON	OFF	ON	ON	OFF	
340	OFF	OFF	ON	ON	ON	OFF	
350	ON	OFF	ON	ON	ON	OFF	
360	OFF	ON	ON	ON	ON	OFF	
370	ON	ON	ON	ON	ON	OFF	
400	OFF	OFF	OFF	OFF	OFF	ON	
500	OFF	OFF	OFF	ON	OFF	ON	
600	OFF	OFF	OFF	OFF	ON	ON	
700	OFF	OFF	OFF	ON	ON	ON	

5. Ensure that jumper W2 (Figure 2-7) is installed at all times.

**NOTE**

**Jumper W2 should not be removed. It is removed only during module testing at the factory.**

6. Ensure that jumper W3 (Figure 2-7) is installed.

**NOTE**

**Jumper W3 should only be removed if the KMC11-B microprocessor control of AC LO is inhibited.**

- Install the M8206 (Etch Rev D) in the DD11-DK nine-slot backplane (Figure 2-10).

**NOTE**

Ensure that the nonprocessor request (NPR) grant continuity wire between pins CA1 and CB1 of the backplane is removed from the location in which the M8206 is being installed.

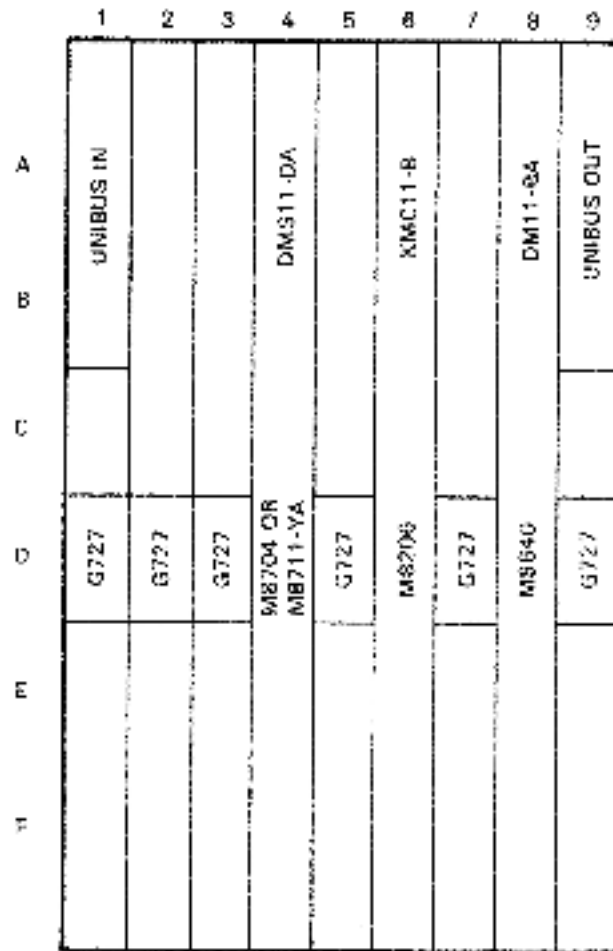

WK 0922

Figure 2-10 DD11-DK Nine-Slot Backplane with KMS11-BD/BE Communications Processor Board Locations (Viewed from the Backplane Pin-Side)

### 2.3.3 KMC11-B (M8206 - Etch Rev E) UNIBUS Microprocessor

To install the KMC11-B (M8206 - Etch Rev E) UNIBUS microprocessor, perform the following:

1. Ensure that the priority plug (level 5) is properly inserted into its socket.
2. Ensure that jumper W1 (Figure 2-11) is installed.

#### NOTE

Jumper W1 should not be removed. It is removed only during module testing at the factory.

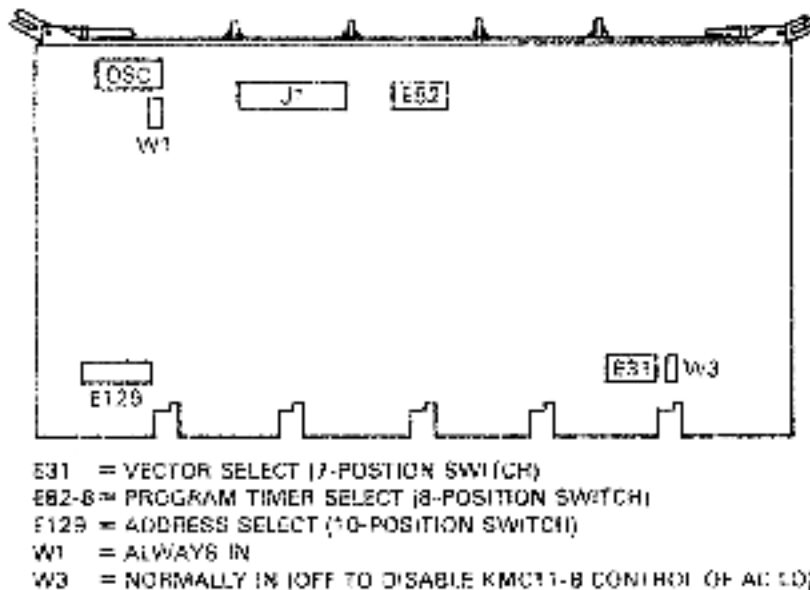

ME 7129

Figure 2-11 KMC11-B (M8206 - Etch Rev E) UNIBUS Microprocessor Board

3. Set the E129 switchpack switches (Figure 2-12) so that the module will respond to its assigned address. (Refer to Table 2-5 for address switch settings.)

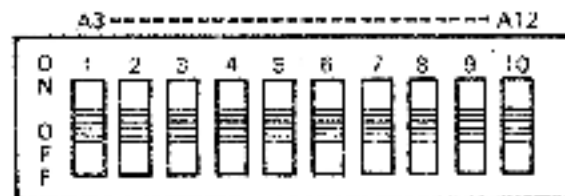

ME 7140

Figure 2-12 KMC11-B (M8206 - Etch Rev E) UNIBUS Microprocessor Address Selection Switch E129

**Table 2-5 KMC11-B (M8206 - Etch Rev E) UNIBUS Microprocessor  
Address Selection Switch E129 Settings**

Address	E129 Switch Settings									
	S1 (A3)	S2 (A4)	S3 (A5)	S4 (A6)	S5 (A7)	S6 (A8)	S7 (A9)	S8 (A10)	S9 (A11)	S10 (A12)
760000	ON	ON	ON	ON	ON	ON	ON	ON	ON	ON
760010	OFF	ON	ON	ON	ON	ON	ON	ON	ON	ON
760020	ON	OFF	ON	ON	ON	ON	ON	ON	ON	ON
760030	OFF	OFF	ON	ON	ON	ON	ON	ON	ON	ON
760040	ON	ON	OFF	ON	ON	ON	ON	ON	ON	ON
760050	OFF	ON	OFF	ON	ON	ON	ON	ON	ON	ON
760060	ON	OFF	OFF	ON	ON	ON	ON	ON	ON	ON
760070	OFF	OFF	OFF	ON	ON	ON	ON	ON	ON	ON
760100	ON	ON	ON	OFF	ON	ON	ON	ON	ON	ON
-										
760200	ON	ON	ON	ON	OFF	ON	ON	ON	ON	ON
-										
760300	ON	ON	ON	OFF	OFF	ON	ON	ON	ON	ON
-										
760400	ON	ON	ON	ON	ON	OFF	ON	ON	ON	ON
-										
760500	ON	ON	ON	OFF	ON	OFF	ON	ON	ON	ON
-										
760600	ON	ON	ON	ON	OFF	OFF	ON	ON	ON	ON
-										
760700	ON	ON	ON	OFF	OFF	OFF	ON	ON	ON	ON
-										
761000	ON	ON	ON	ON	ON	ON	OFF	ON	ON	ON
-										
762000	ON	ON	ON	ON	ON	ON	ON	OFF	ON	ON
-										
763000	ON	ON	ON	ON	ON	ON	OFF	OFF	ON	ON
-										
764000	ON	ON	ON	ON	ON	ON	ON	ON	OFF	ON
-										
765000	ON	ON	ON	ON	ON	ON	OFF	ON	OFF	ON
-										
766000	ON	ON	ON	ON	ON	ON	ON	OFF	OFF	ON
-										
767000	ON	ON	ON	ON	ON	ON	OFF	OFF	OFF	ON
-										
770000	ON	ON	ON	ON	ON	ON	ON	ON	ON	OFF
-										
777770	OFF	OFF	OFF	OFF	OFF	OFF	OFF	OFF	OFF	OFF

4. Set the E31 switchpack switches (Figure 2-13) to the proper vector selection. (Refer to Table 2-6 for vector switch settings.)

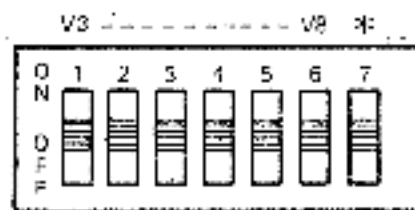

Figure 2-13 KMC11-B (M8206 - Etch Rev E) UNIBUS Microprocessor Vector Selection Switch E31

Table 2-6 KMC11-B (M8206 - Etch Rev E) UNIBUS Microprocessor Vector Selection Switch E31 Settings

Vector	E31 Switch Settings						
	S1 (V3)	S2 (V4)	S3 (V5)	S4 (V6)	S5 (V7)	S6 (V8)	S7 (Not Used)
300	OFF	OFF	OFF	ON	ON	OFF	
310	ON	OFF	OFF	ON	ON	OFF	
320	OFF	ON	OFF	ON	ON	OFF	
330	ON	ON	OFF	ON	ON	OFF	
340	OFF	OFF	ON	ON	ON	OFF	
350	ON	OFF	ON	ON	ON	OFF	
360	OFF	ON	ON	ON	ON	OFF	
370	ON	ON	ON	ON	ON	OFF	
400	OFF	OFF	OFF	OFF	OFF	ON	
500	OFF	OFF	OFF	ON	OFF	ON	
600	OFF	OFF	OFF	OFF	ON	ON	
700	OFF	OFF	OFF	ON	ON	ON	

5. Ensure that jumper W3 (Figure 2-11) is installed.

**NOTE**

**Jumper W3 should only be removed if the KMC11-B microprocessor control of AC LO is inhibited.**

6. Set the E82-8 switchpack switches (Figure 2-14) for the proper timeout value.



MK-4517

Figure 2-14 KMC11-B (M8206 – Etch Rev E) UNIBUS Microprocessor Programmer Timer Selection Switch E82

**NOTE**

**When switchpack E82-8 is ON, a timeout value of 115 milliseconds is provided. When switchpack E82-8 is OFF, a timeout value of 75 microseconds is provided.**

**At present, the timeout values required for known software are as follows:**

DDCMP (CSS)	Either
X.25 (CSS)	115 ms
ADDCP (CSS)	115 ms
BX.25 (Bell)	75 $\mu$ s

7. Install the M8206 (Etch Rev E) in the appropriate location in the DD11-DK nine-slot backplane (Figure 2-15).

**NOTE**

Ensure that the nonprocessor request (NPR) grant continuity wire between pins CA1 and CB1 of the backplane is removed from the location in which the M8206 is being installed.

	1	2	3	4	5	6	7	8	9
A	UNIBUS IN			DM811-DA	M8206	KM11-B	DM11-BA	UNIBUS OUT	
B									
C				M8704 OR M8711-YA	M8206	M8640	M8640	G727	
D	G727	G727	G727						G727
E									
F									

46-3132

Figure 2-15 DD11-DK Nine-Slot Backplane with KMS11-BD/BE Communications Processor Board Locations (Viewed from the Backplane Pin-Side)

### 2.3.4 DM11-BA (M8640 - Etc Rev B) Modem Control Multiplexer

To install the DM11-BA (M8640 - Etc Rev B) modem control multiplexer, perform the following:

1. Ensure that the priority insert (level 4) is properly inserted into its socket.
2. Set the E108 switchpack switches (Figure 2-17) and jumper W1 (Figure 2-16) so that the module will respond to its assigned address. (Refer to Table 2-7 for address switch settings.)

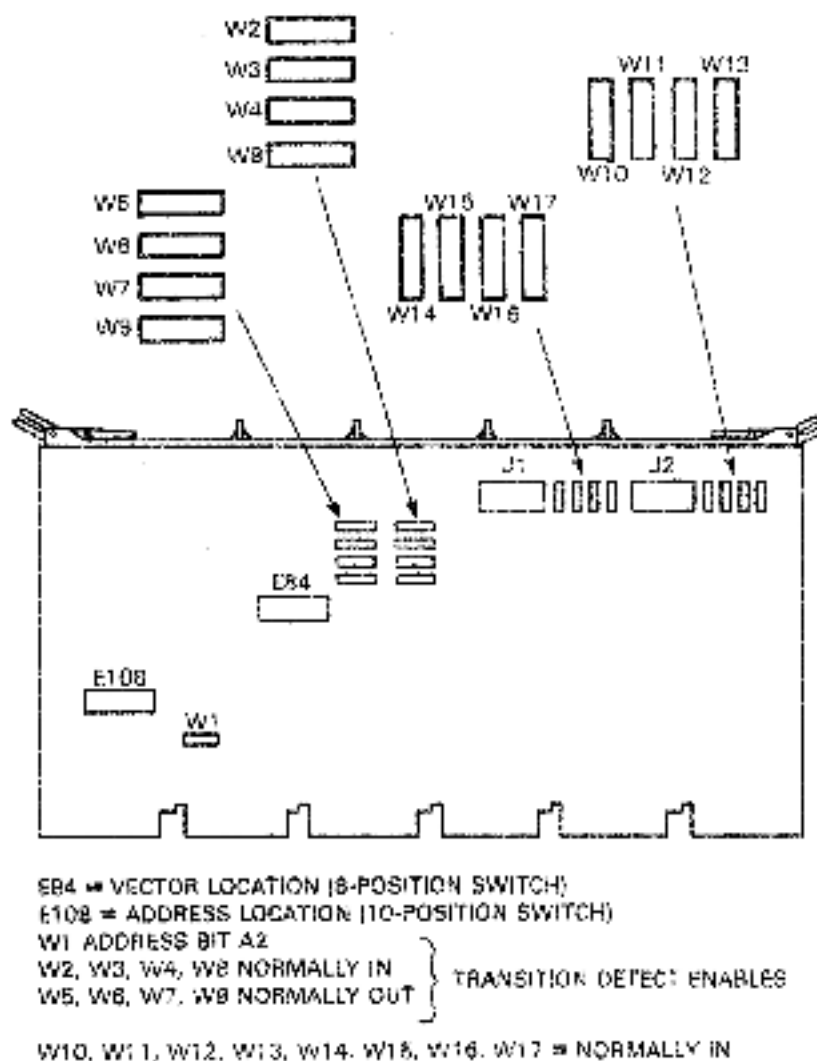

MS-3170

Figure 2-16 DM11-BA (M8640 - Etc Rev B) Modem Control Multiplexer Board

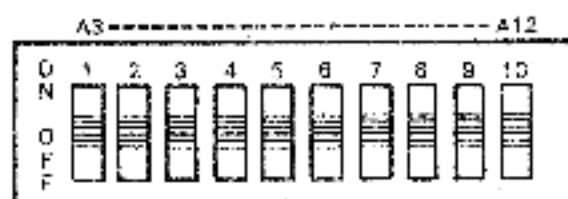

MC-2267

Figure 2-17 DM11-BA (M8640 - Etch Rev B) Modem Control Multiplexer Address Selection Switch E108

Table 2-7 DM11-BA (M8640 - Etch Rev B) Modem Control Multiplexer Address Selection Jumper (W1) and Switch (E108) Settings

Address	Jumper/Switch Settings										
	W1	S1 (A3)	S2 (A4)	S3 (A5)	S4 (A6)	S5 (A7)	S6 (A8)	S7 (A9)	S8 (A10)	S9 (A11)	S10 (A12)
760000	OUT	OFF	OFF	OFF	OFF	OFF	OFF	OFF	OFF	OFF	OFF
760004	IN	OFF	OFF	OFF	OFF	OFF	OFF	OFF	OFF	OUT	OFF
760010	OUT	ON	OFF	OFF	OFF	OFF	OFF	OFF	OFF	OFF	OFF
760020	OUT	OFF	ON	OFF	OFF	OFF	OFF	OFF	OFF	OFF	OFF
760030	OUT	ON	ON	OFF	OFF	OFF	OFF	OFF	OFF	OFF	OFF
760040	OUT	OFF	OFF	ON	OFF	OFF	OFF	OFF	OFF	OFF	OFF
760050	OUT	ON	OFF	ON	OFF	OFF	OFF	OFF	OFF	OFF	OFF
760060	OUT	OFF	ON	ON	OFF	OFF	OFF	OFF	OFF	OFF	OFF
760070	OUT	ON	ON	ON	OFF	OFF	OFF	OFF	OFF	OFF	OFF
760100	OUT	OFF	OFF	OFF	ON	OFF	OFF	OFF	OFF	OFF	OFF
760200	OUT	OFF	OFF	OFF	OFF	ON	OFF	OFF	OFF	OFF	OFF
760300	OUT	OFF	OFF	OFF	ON	ON	OFF	OFF	OFF	OFF	OFF
760400	OUT	OFF	OFF	OFF	OFF	OFF	ON	OFF	OFF	OFF	OFF
760500	OUT	OFF	OFF	OFF	ON	OFF	ON	OFF	OFF	OFF	OFF
760600	OUT	OFF	OFF	OFF	OFF	ON	ON	OFF	OFF	OFF	OFF
760700	OUT	OFF	OFF	OFF	ON	ON	ON	OFF	OFF	OFF	OFF

Table 2-7 DM11-BA (M8640 - Etc Rev B) Modem Control Multiplexer  
Address Selection Jumper (W1) and Switch (E108) Settings (Cont)

Address	Jumper/Switch Settings										
	W1	S1 (A3)	S2 (A4)	S3 (A5)	S4 (A6)	S5 (A7)	S6 (A8)	S7 (A9)	S8 (A10)	S9 (A11)	S10 (A12)
761000	OUT	OFF	OFF	OFF	OFF	OFF	OFF	ON	OFF	OFF	OFF
762000	OUT	OFF	OFF	OFF	OFF	OFF	OFF	OFF	ON	OFF	OFF
763000	OUT	OFF	OFF	OFF	OFF	OFF	OFF	ON	ON	OFF	OFF
764000	OUT	OFF	OFF	OFF	OFF	OFF	OFF	OFF	OFF	ON	OFF
765000	OUT	OFF	OFF	OFF	OFF	OFF	OFF	ON	OFF	ON	OFF
766000	OUT	OFF	OFF	OFF	OFF	OFF	OFF	OFF	ON	ON	OFF
767000	OUT	OFF	OFF	OFF	OFF	OFF	OFF	ON	ON	ON	OFF
770000	OUT	OFF	OFF	OFF	OFF	OFF	OFF	OFF	OFF	OFF	ON
777774	IN	ON	ON	ON	ON	ON	ON	ON	ON	ON	ON

- Set the E84 switchpack switches (Figure 2-18) so that proper vector selection can be accomplished. (Refer to Table 2-8 for vector switch settings.)



\* S8 NOT USED

DF-1004

Figure 2-18 DM11-BA (M8640 - Etc Rev B) Modem Control  
Multiplexer Vector Selection Switch E84

**Table 2-8 DM11-BA (M8640 – Erch Rev B) Modem Control Multiplexer  
Vector Selection Switch E84 Settings**

Vector	E84 Switch Settings							
	S1 (V2)	S2 (V3)	S3 (V4)	S4 (V5)	S5 (V6)	S6 (V7)	S7 (V8)	S8 (Not Used)
300	ON	ON	ON	ON	OFF	OFF	ON	
304	OFF	ON	ON	ON	OFF	OFF	ON	
310	ON	OFF	ON	ON	OFF	OFF	ON	
320	ON	ON	OFF	ON	OFF	OFF	ON	
330	ON	OFF	OFF	ON	OFF	OFF	ON	
340	ON	ON	ON	OFF	OFF	OFF	ON	
350	ON	OFF	ON	OFF	OFF	OFF	ON	
360	ON	ON	OFF	OFF	OFF	OFF	ON	
370	ON	OFF	OFF	OFF	OFF	OFF	ON	
400	ON	ON	ON	ON	ON	ON	OFF	
500	ON	ON	ON	ON	OFF	ON	OFF	
600	ON	ON	ON	ON	ON	OFF	OFF	
700	ON	ON	ON	ON	OFF	OFF	OFF	

4. Ensure that jumpers W10 through W17 (Figure 2-16), located near connectors J1 and J2, are always IN.
5. Ensure that jumpers W2, W3, W4, and W8 are IN and W5, W6, W7, and W9 (Figure 2-16) are OUT.

**NOTE**

To individually or totally disable DSR, CS, CO, or Ring from causing interrupts, insert jumpers W5, W6, W7, and W9 and remove jumpers W2, W3, W4, and W8.

6. Connect the two BC08R-10 cables to the M8640 module and either the H317-M distribution panel (Figure 3-3) or the H317-P distribution panel (Figure 3-6).

7. Install the M8640 (Fitch Rev B) in the appropriate location in the DD11-DK nine-slot backplane (Figure 2-19).

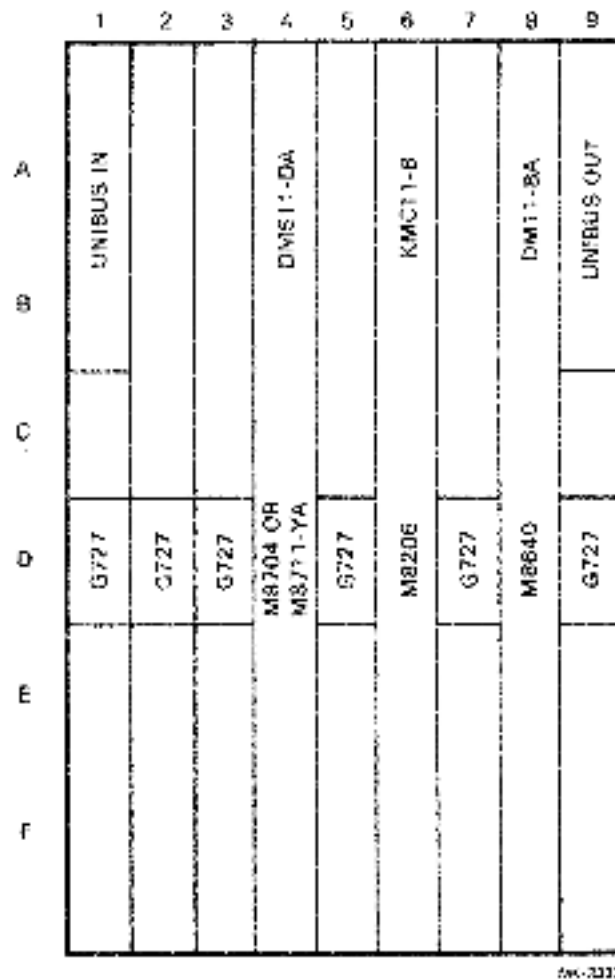
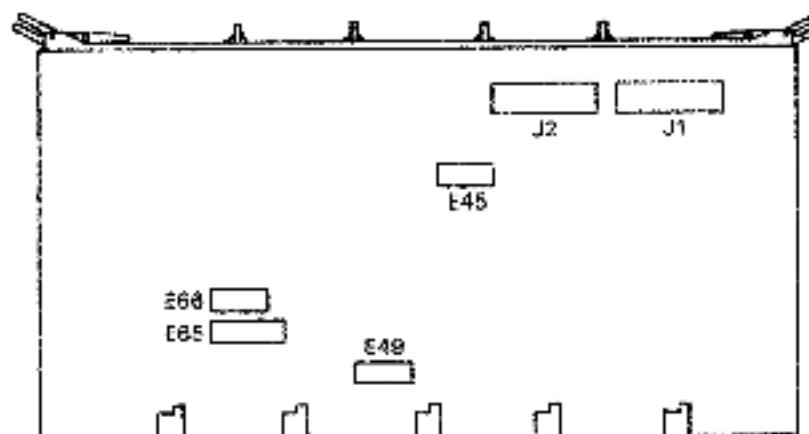

Figure 2-19 DD11-DK Nine-Slot Backplane with KMS11-BD/BE Communications Processor Board Locations (Viewed from the Backplane Pin-Side)

### 2.3.5 DM11-BA (M8640 - Etch Rev C) Modem Control Multiplexer

To install the DM11-BA (M8640 - Etch Rev C) modem control multiplexer, perform the following:

1. Ensure that the priority insert (level 4) is properly inserted into its socket.
2. Set the E45 switchpack switches (Figure 2-20) ON for RS-232-C operation or OFF for RS-423-A operation.



E45 RS-232-C = ON RS-423-A = OFF (B-POSITION SWITCH)  
 E49 VECTOR SELECT (E49-8 = ADDRESS BIT A2: 8-POSITION SWITCH)  
 E68 TRANSITION DETECT ENABLE (SEE TABLE 2-12)  
 E65 ADDRESS SELECT (10-POSITION SWITCH)

MK-3246

Figure 2-20 DM11-BA (M8640 - Etch Rev C) Modem Control Multiplexer Board

3. Set the E49-8 and E65 switchpack switches (Figure 2-21) so that the module will respond to its assigned address. (Refer to Table 2-9 for address switch settings.)

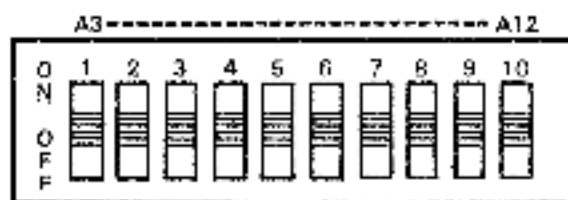

MK-3245

Figure 2-21 DM11-BA (M8640 - Etch Rev C) Modem Control Multiplexer Address Selection Switch E65

**Table 2-9 DM11-BA (M8640 - Etch Rev C) Modem Control  
Multiplexer Address Selection Switches E49-8 and E65 Settings**

Address	Jumper/Switch Settings										
	E49	E65									
	S8 (A2)	S1 (A3)	S2 (A4)	S3 (A5)	S4 (A6)	S5 (A7)	S6 (A8)	S7 (A9)	S8 (A10)	S9 (A11)	S10 (A12)
760000	OFF	OFF	OFF	OFF	OFF	OFF	OFF	OFF	OFF	OFF	OFF
760004	ON	OFF	OFF	OFF	OFF	OFF	OFF	OFF	OFF	OFF	OFF
760010	OFF	ON	OFF	OFF	OFF	OFF	OFF	OFF	OFF	OFF	OFF
760020	OFF	OFF	ON	OFF	OFF	OFF	OFF	OFF	OFF	OFF	OFF
760030	OFF	ON	ON	OFF	OFF	OFF	OFF	OFF	OFF	OFF	OFF
760040	OFF	OFF	OFF	ON	OFF	OFF	OFF	OFF	OFF	OFF	OFF
760050	OFF	ON	OFF	ON	OFF	OFF	OFF	OFF	OFF	OFF	OFF
760060	OFF	OFF	ON	ON	OFF	OFF	OFF	OFF	OFF	OFF	OFF
760070	OFF	ON	ON	ON	OFF	OFF	OFF	OFF	OFF	OFF	OFF
760100	OFF	OFF	OFF	OFF	ON	OFF	OFF	OFF	OFF	OFF	OFF
760200	OFF	OFF	OFF	OFF	OFF	ON	OFF	OFF	OFF	OFF	OFF
760300	OFF	OFF	OFF	OFF	ON	ON	OFF	OFF	OFF	OFF	OFF
760400	OFF	OFF	OFF	OFF	OFF	OFF	ON	OFF	OFF	OFF	OFF
760500	OFF	OFF	OFF	OFF	ON	OFF	ON	OFF	OFF	OFF	OFF
760600	OFF	OFF	OFF	OFF	OFF	ON	ON	OFF	OFF	OFF	OFF
760700	OFF	OFF	OFF	OFF	ON	ON	ON	OFF	OFF	OFF	OFF
761000	OFF	OFF	OFF	OFF	OFF	OFF	OFF	ON	OFF	OFF	OFF
762000	OFF	OFF	OFF	OFF	OFF	OFF	OFF	OFF	ON	OFF	OFF
763000	OFF	OFF	OFF	OFF	OFF	OFF	OFF	ON	ON	OFF	OFF
764000	OFF	OFF	OFF	OFF	OFF	OFF	OFF	OFF	OFF	ON	OFF
765000	OFF	OFF	OFF	OFF	OFF	OFF	OFF	ON	OFF	ON	OFF

**Table 2-9 DM11-BA (M8640 - Etch Rev C) Modem Control  
Multiplexer Address Selection Switches E49-8 and E65 Settings (Cont)**

Address	Jumper/Switch Settings											
	E49	E65										
	S8 (A2)	S1 (A3)	S2 (A4)	S3 (A5)	S4 (A6)	S5 (A7)	S6 (A8)	S7 (A9)	S8 (A10)	S9 (A11)	S10 (A12)	
766000	OFF	OFF	OFF	OFF	OFF	OFF	OFF	OFF	OFF	ON	ON	OFF
767000	OFF	OFF	OFF	OFF	OFF	OFF	OFF	ON	ON	ON	ON	OFF
770000	OFF	OFF	OFF	OFF	OFF	OFF	OFF	OFF	OFF	OFF	OFF	ON
777774	ON	ON	ON	ON	ON	ON	ON	ON	ON	ON	ON	ON

- Set the E49 switchpack switches (Figure 2-22) so that proper vector selection can be accomplished. (Refer to Table 2-10 for vector switch settings.)

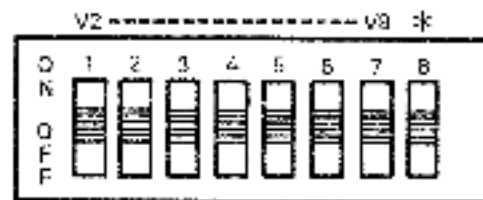

\* SWITCH 8 IS USED FOR ADDRESS SELECTION A2

92-2110

**Figure 2-22 DM11-BA (M8640 - Etch Rev C) Modem Control  
Multiplexer Vector Selection Switch E49**

Table 2-10 DM11-BA (M8640 - Etch Rev C) Modem Control  
Multiplexer Vector Selection Switch E49 Settings

Vector	E49 Switch Settings							
	S1 (V2)	S2 (V3)	S3 (V4)	S4 (V5)	S5 (V6)	S6 (V7)	S7 (V8)	S8 (Not Used)
300	ON	ON	ON	ON	OFF	OFF	ON	
304	OFF	ON	ON	ON	OFF	OFF	ON	
310	ON	OFF	ON	ON	OFF	OFF	ON	
320	ON	ON	OFF	ON	OFF	OFF	ON	
330	ON	OFF	OFF	ON	OFF	OFF	ON	
340	ON	ON	ON	OFF	OFF	OFF	ON	
350	ON	OFF	ON	OFF	OFF	OFF	ON	
360	ON	ON	OFF	OFF	OFF	OFF	ON	
370	ON	OFF	OFF	OFF	OFF	OFF	ON	
400	ON	ON	ON	ON	ON	ON	OFF	
500	ON	ON	ON	ON	OFF	ON	OFF	
600	ON	ON	ON	ON	ON	OFF	OFF	
700	ON	ON	ON	ON	OFF	OFF	OFF	

- Set the E66 switchpack switches (Figure 2-23) to either enable or disable CSR, CS, CO, or Ring interrupts. (Refer to Table 2-11).



MS 4571

Figure 2-23 DM11-BA (M8640 - Etch Rev C) Modem Control  
Multiplexer Switchpack E66

- Connect the two BC08R-10 cables to the M8640 module and to either the H317-M distribution panel (Figure 3-3) or the H317-P distribution panel (Figure 3-6).

**Table 2-11 DM11-BA (M8640 -- Etch Rev C) Modem Control Multiplexer Switchpack E66 Settings**

Switch Number	Modem Input	Interrupt Enabled	Interrupt Disabled
S1	Ring	OFF	ON
S2	Ring	ON	OFF
S3	CO	OFF	ON
S4	CO	ON	OFF
S5	CS	OFF	ON
S6	CS	ON	OFF
S7	DSR	OFF	ON
S8	DSR	ON	OFF

7. Install the M8640 (Etch Rev C) in the appropriate location in the DD11-DK nine-slot backplane (Figure 2-24).

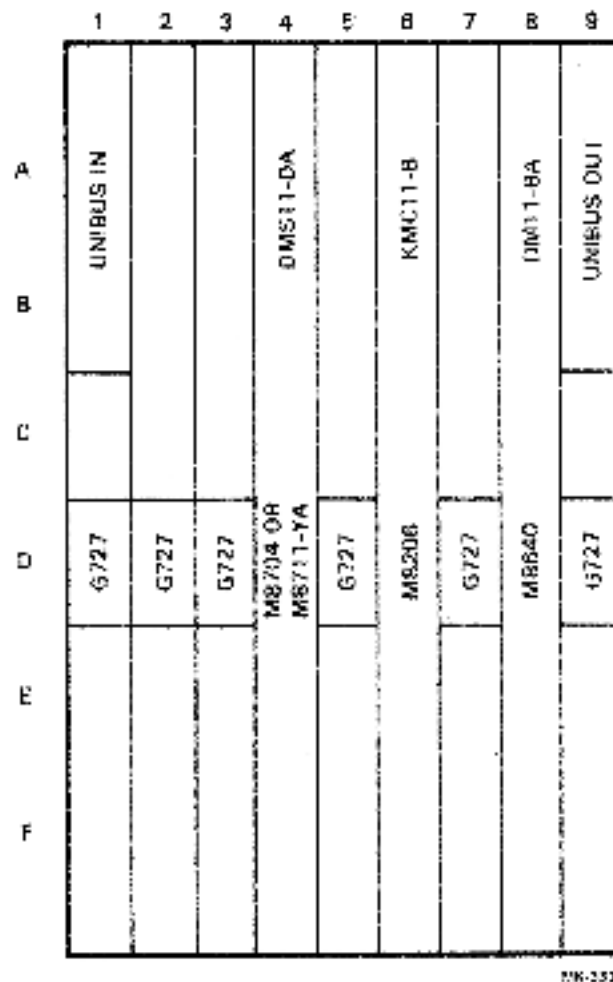

**Figure 2-24 DD11-DK Nine-Slot Backplane with KMS11-BD/BE Communications Processor Board Locations (Viewed from the Backplane Pin-Side)**

### 2.3.6 DMS11-D/DA (M8704) Synchronous Line Unit

To install the DMS11-DA (M8704) synchronous line unit, perform the following:

1. Ensure that switchpack switches E1, E4, and E10 (Figure 2-25) are set to select either RS-232-C or RS-423-A compatibility. (Refer to Figure 2-26 for switch locations and to Table 2-12 for switchpack settings.)

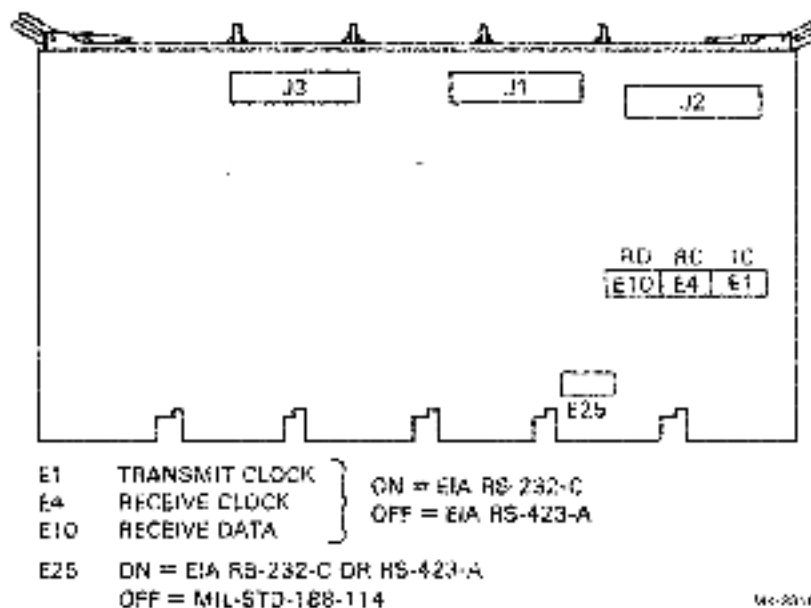

Figure 2-25 DMS11-D/DA (M8704) Synchronous Line Unit Board

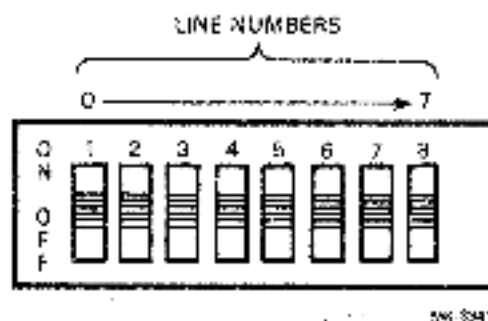

Figure 2-26 DMS11-D/DA (M8704) Synchronous Line Unit Typical Switchpack

Table 2-12 DMS11-D/DA (M8704) Synchronous Line Unit Switchpack E1, E4, E10, and E25 Settings

Standard	Switchpack			
	E1	E4	E10	E25
EIA-RS-232-C	ON	ON	ON	ON
EIA-RS-423-A	OFF	OFF	OFF	ON
MIL-STD-188-114	-	-	-	OFF

2. Select either EIA (RS-232-C and RS-423-A) or MIL-188-C polarities by setting switchpack switches on E25. (Refer to Figure 2-25 for the switchpack location and to Table 2-12 for switchpack settings.)
3. Connect the two BC11W-10 cables from J1 and J2 of the M8704 module to the H317-M distribution panel (Figure 3-4) or to the H317-P distribution panel (Figure 3-7).

**NOTE**

Cables are seated with the arrow on the cable connector aligned with the arrow on the module connector.

4. Install the M8704 in the appropriate location in the DD11-DK nine-slot backplane (Figure 2-27).

**CAUTION**

Do not sag any unit cables.

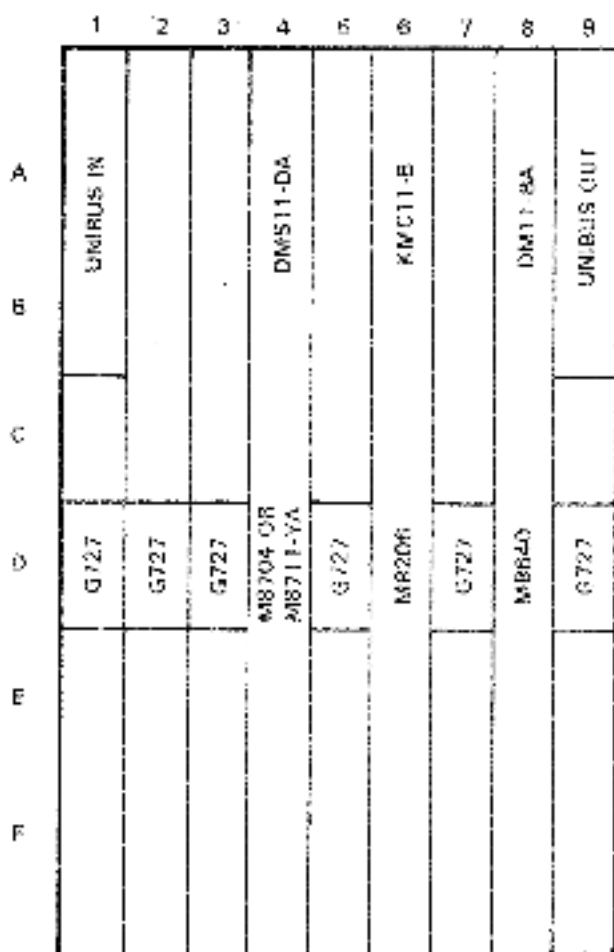

WH 8827

Figure 2-27 DD11-DK Nine-Slot Backplane with KMS11-BD/BE Communications Processor Board Locations (Viewed from the Backplane Pin-Side)

5. Connect one end of a BC08R-01 cable to J3 on the M8704 module and the other end of the BC08R-01 cable to J1 on the M8206 module.

### 2.3.7 DMS11-DA (M8711-YA - Etch Rev A) Eight-Line Synchronous Line Unit

#### NOTE

All M8711-YA modules are preset and configured during manufacturing.

To install the DMS11-DA (M8711-YA - Etch Rev A) line unit (Figure 2-28), perform the following:

1. Connect the two BC11W-10 cables from J1 and J2 of the M8711-YA module to the H317-M distribution panel (Figure 3-5) or to the H317-P distribution panel (Figure 3-8).

#### NOTE

Cables are seated with the arrow on the cable connector aligned with the arrow on the module connector.

2. Connect a BC08R-01 cable to J3 of the DMS11-DA line unit.

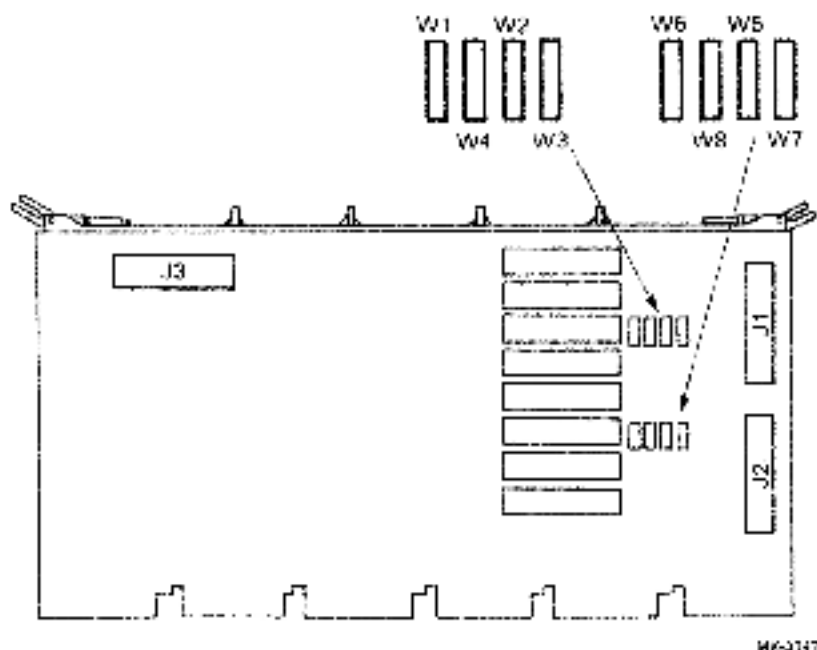
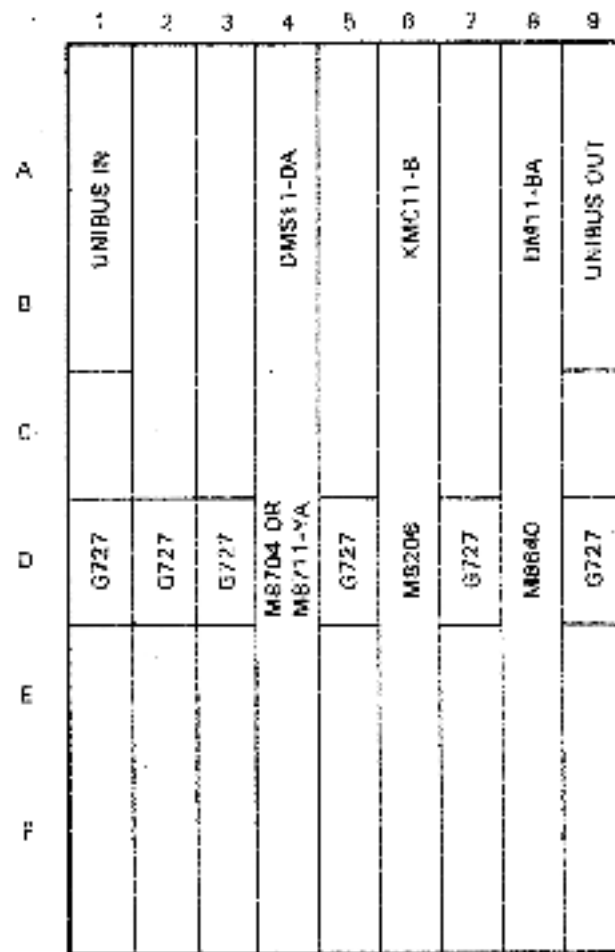

Figure 2-28 DMS11-DA (M8711-YA - Etch Rev A) Eight-Line Synchronous Line Unit Board

3. Install the M8711-YA (Etch Rev A) in the appropriate location in the DD11-DK nine-slot backplane (Figure 2-29).

#### CAUTION

Do not snag any unit cables.



MR-3782

Figure 2-29 DD11-DK Nine-Slot Backplane with KMS11-BD/BE Communications Processor Board Locations (Viewed from the Backplane Pin-Side)

4. Connect the other end of the BC08R-01 cable, which is connected to J3, to J1 on the M8206 module.

### 2.3.8 DMS11-DA (M8711-YA - Etch Rev B) Eight-Line Synchronous Line Unit

#### NOTE

All M8711-YA modules are preset and configured during manufacturing.

To install the DMS11-DA (M8711-YA - Etch Rev B) line unit (Figure 2-30), perform the following:

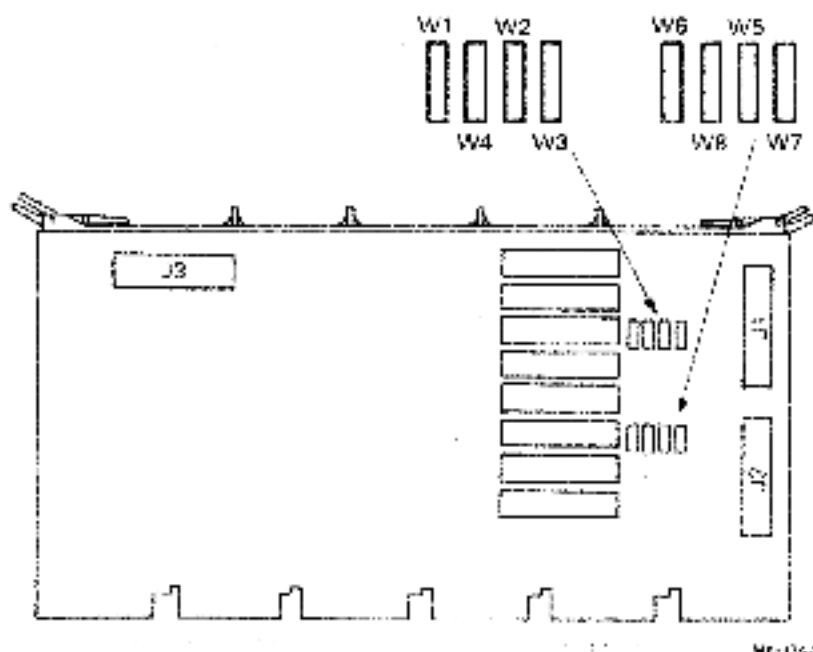

Figure 2-30 DMS11-DA (M8711-YA - Etch Rev B) Eight-Line Synchronous Line Unit Board

1. Connect two BC11W-10 cables from J1 and J2 of the M8711-YA module to the H317-M distribution panel (Figure 3-5) or to the H317-P distribution panel (Figure 3-8).

#### NOTE

Cables are seated with the arrow on the cable connector aligned with the arrow on the module connector.

2. Connect a BC08R-01 cable to J3 of the DMS11-DA line unit.
3. Install the M8711-YA (Etch Rev B) in the appropriate location in the DD11-DK nine-slot backplane (Figure 2-31).

#### CAUTION

Do not snag any unit cables.

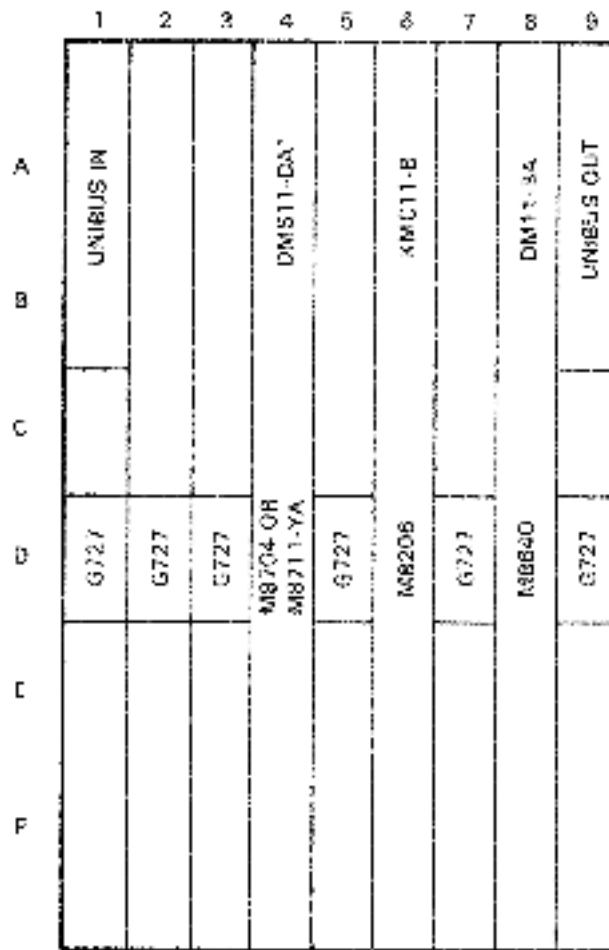

94-3222

Figure 2-31 DD11-DK Nine-Slot Backplane with KMS11-BD/BE Communications Processor Board Locations (Viewed from the Backplane Pin-Side)

4. Connect the other end of the BC08R-01 cable, which is connected to J3, to J1 on the M8206 module.



## CHAPTER 3 SYSTEM CONFIGURATION

### 3.1 INTRODUCTION

This chapter is designed to give a basic understanding of how the KMS11-BD/BE synchronous communications processor option is configured to UNIBUS connector systems and the cabling that is required before the KMS11-BD/BE communications processor can be installed.

### 3.2 SYSTEM CONFIGURATION

The KMS11-BD/BE communications processor option is an intelligent, eight-line, communications interface that can be configured on UNIBUS connector systems. (Refer to Figure 3-1 for the UNIBUS connector configuration.)

The KMS11-BD/BE communications processor (Figure 3-1) consists of:

- A KMC11-B general purpose microprocessor,
- A DMS11-DA line unit,
- A DM11-BA modem control multiplexer, and
- Either an H317-M or H317-P distribution panel.

When configuring the KMS11-BD/BE communications processor option to UNIBUS connector systems, the DD11-DK backplane is used. The DD11-DK backplane is a nine-slot backplane that accommodates all of the KMS11 communications processor option boards.

#### CAUTION

To ensure proper air circulation for cooling purposes, one blank slot must be left between each board when placed in the DD11-DK backplane. (Refer to Figure 3-2 for proper module placement.)

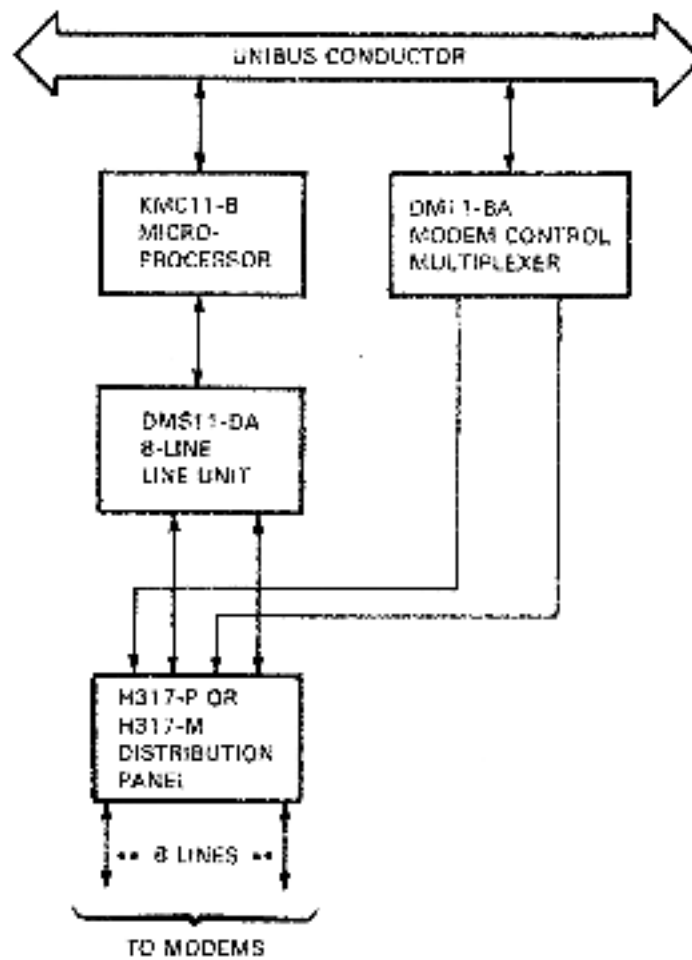

KMS11-B

Figure 3-4 KMS11-BD/BE Communications Processor UNIBUS Connector Interface

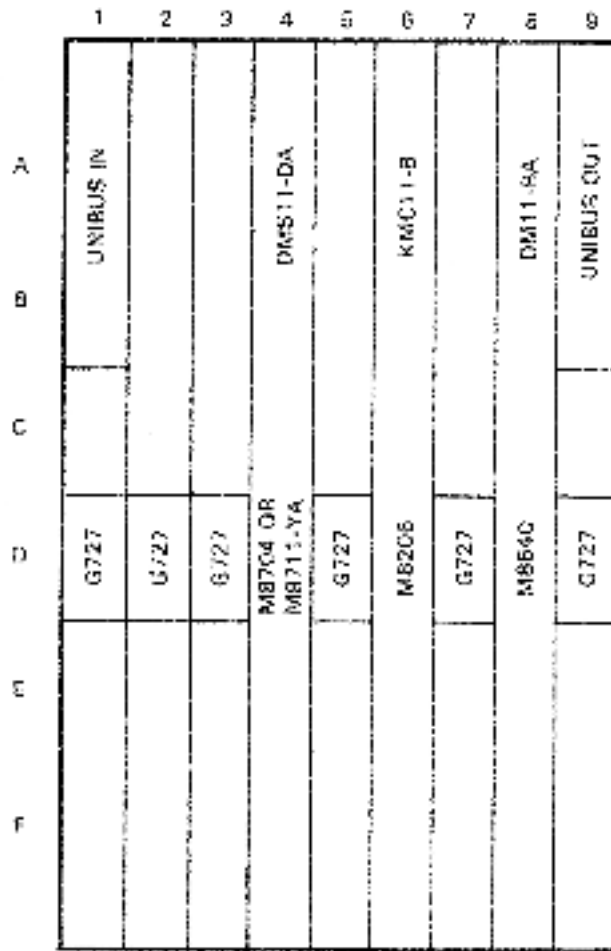

MR 2772

Figure 3-2 DD11-DK Nine-Slot Backplane (Viewed from the Backplane Pin-Side)

### 3.3 SYSTEM CABLING

#### 3.3.1 DM11-BA (M8640) Multiplexer Cabling to an H317-M Distribution Panel

When configuring the DM11-BA modem control multiplexer, two BC08R cables are used. To configure the DM11-BA multiplexer to the H317-M distribution panel, connect the cables as shown in Figure 3-3.

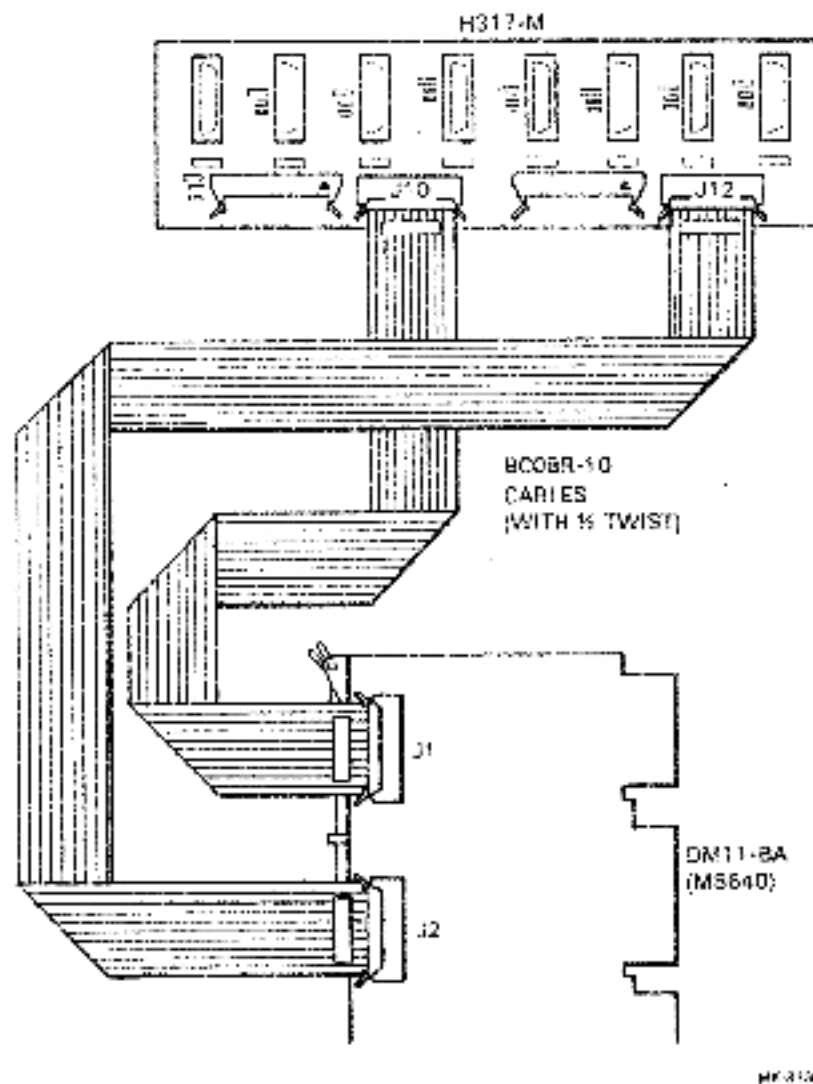
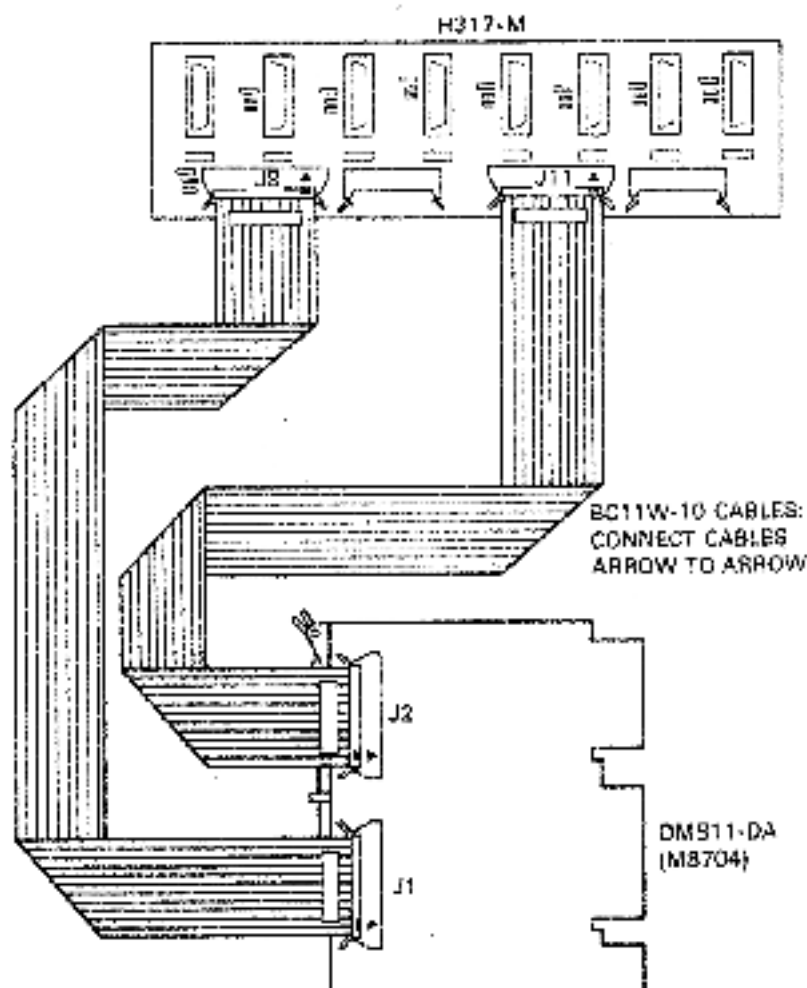

Figure 3-3 DM11-BA (M8640) Multiplexer to H317-M Distribution Panel Cabling

### 3.3.2 DMS11-DA (M8704) Line Unit Cabling to an H317-M Distribution Panel

When configuring the DMS11-DA synchronous line unit, two BC11W-10 cables are used. To configure the DMS11-DA line unit to the H317-M distribution panel, connect the cables as shown in Figure 3-4.



rw-6887

Figure 3-4 DMS11-DA (M8704) Line Unit to H317-M Distribution Panel Cabling

### 3.3.3 DMS11-DA (M8711-YA) Line Unit Cabling to an H317-M Distribution Panel

When configuring the DMS11-DA synchronous line unit, two BC11W-10 cables are used. To configure the DMS11-DA line unit to the H317-M distribution panel, connect the cables as shown in Figure 3-5.

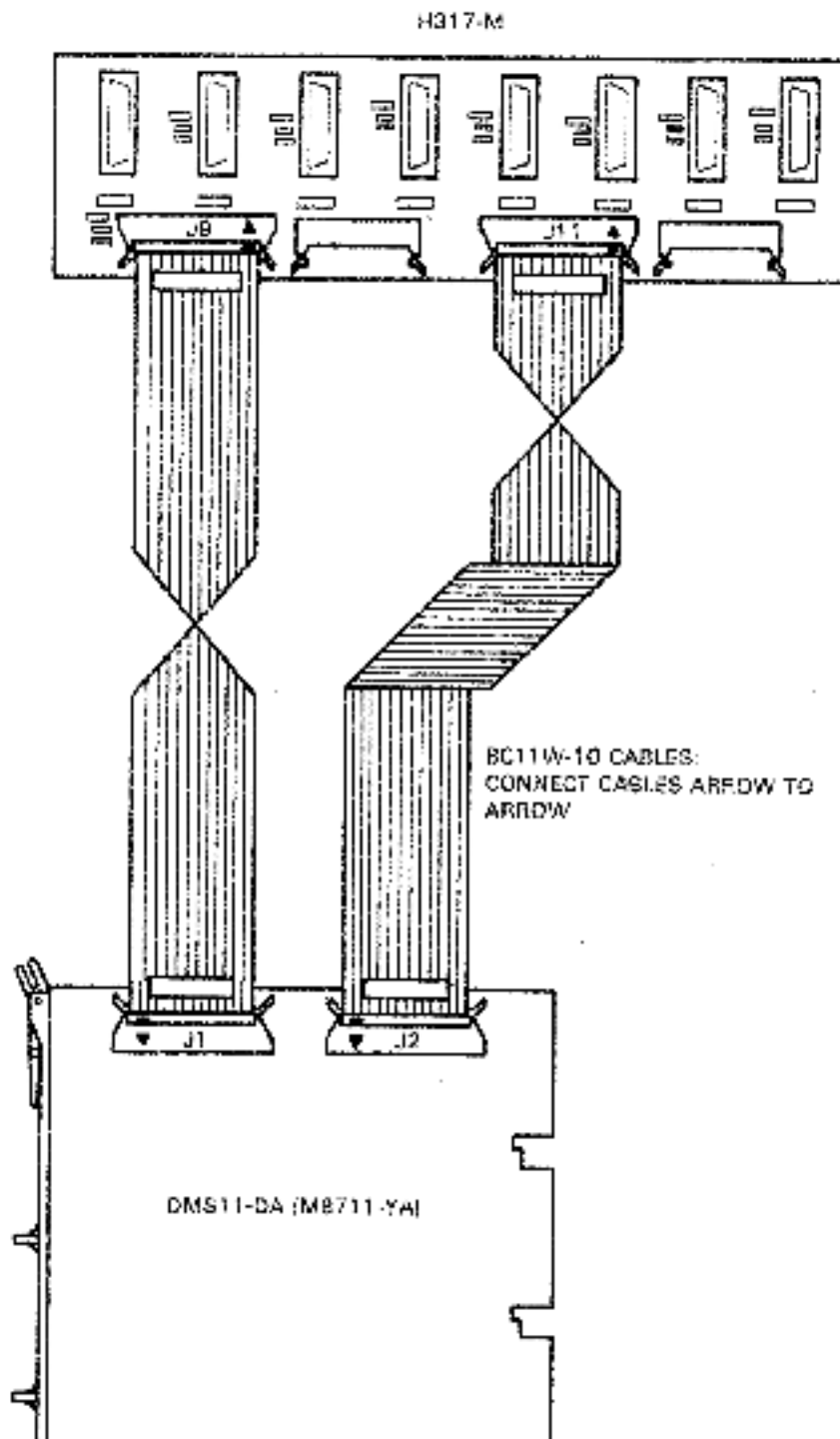

WC-9328

Figure 3-5 DMS11-DA (M8711-YA) Line Unit to H317-M Distribution Panel Cabling

### 3.3.4 DM11-BA (M8640) Multiplexer Cabling to an H317-P Distribution Panel

When configuring the DM11-BA modem control multiplexer, two BC08R cables are used. To configure the DM11-BA multiplexer in the H317-P distribution panel, connect the cables as shown in Figure 3-6.

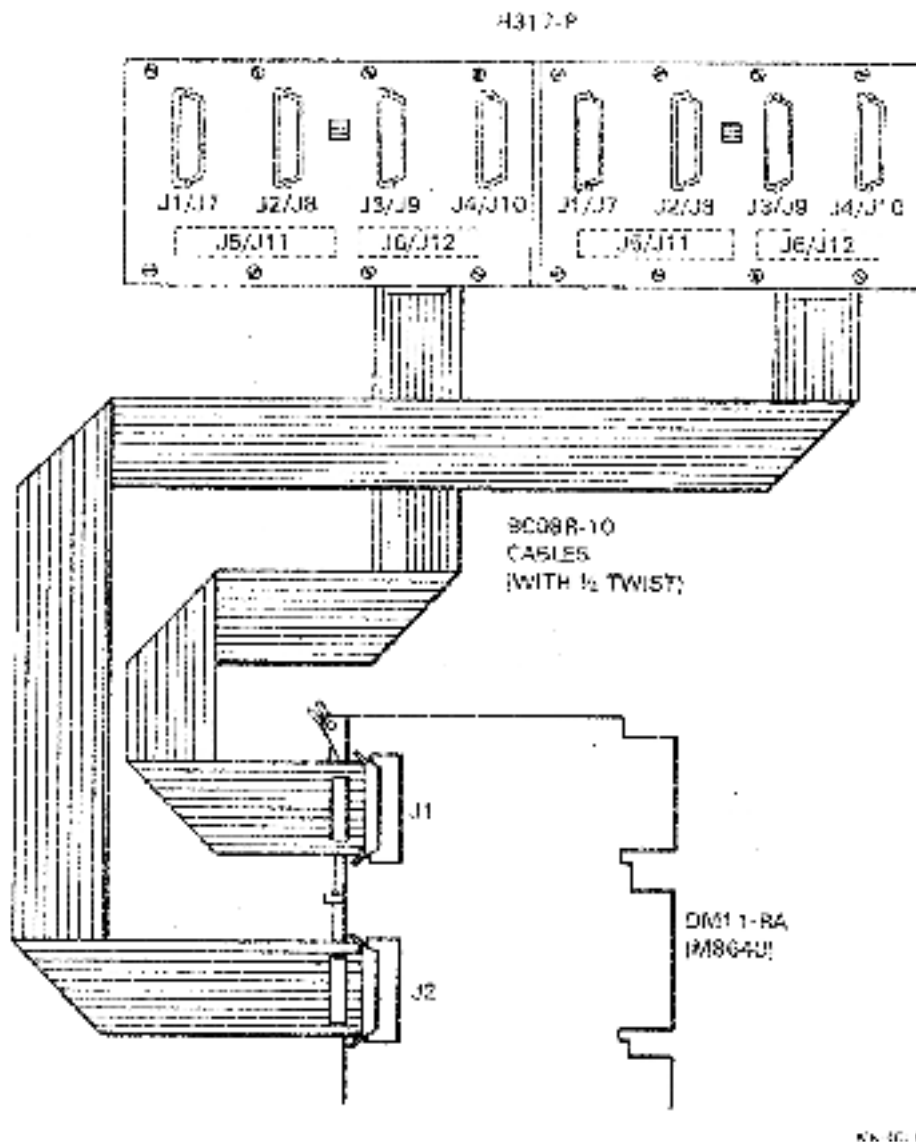

Figure 3-6 DM11-BA (M8640) Multiplexer to H317-P Distribution Panel Cabling

### 3.3.5 DMS11-DA (M8704) Line Unit Cabling to an H317-P Distribution Panel

When configuring the DMS11-DA synchronous line unit, two BC11W-10 cables are used. To configure the DMS11-DA line unit to the H317-P distribution panel, connect the cables as shown in Figure 3-7.

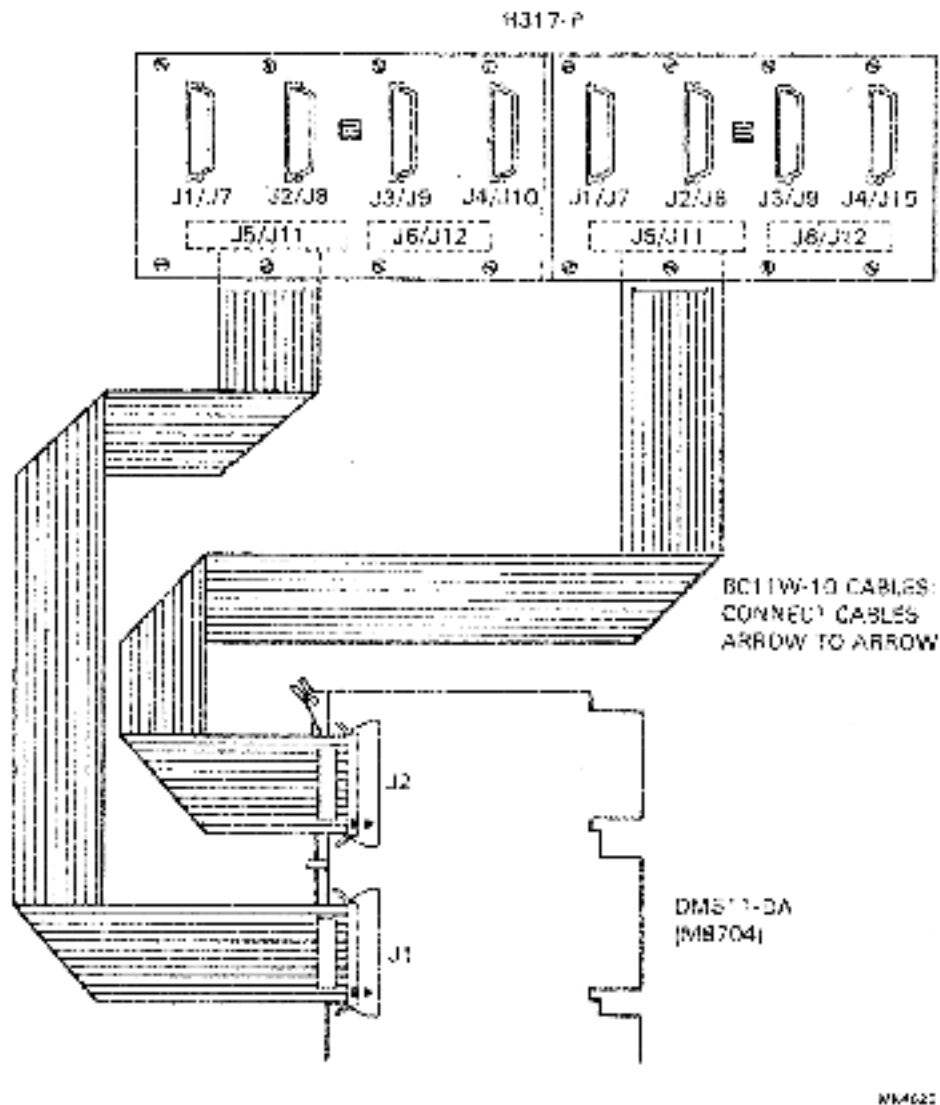
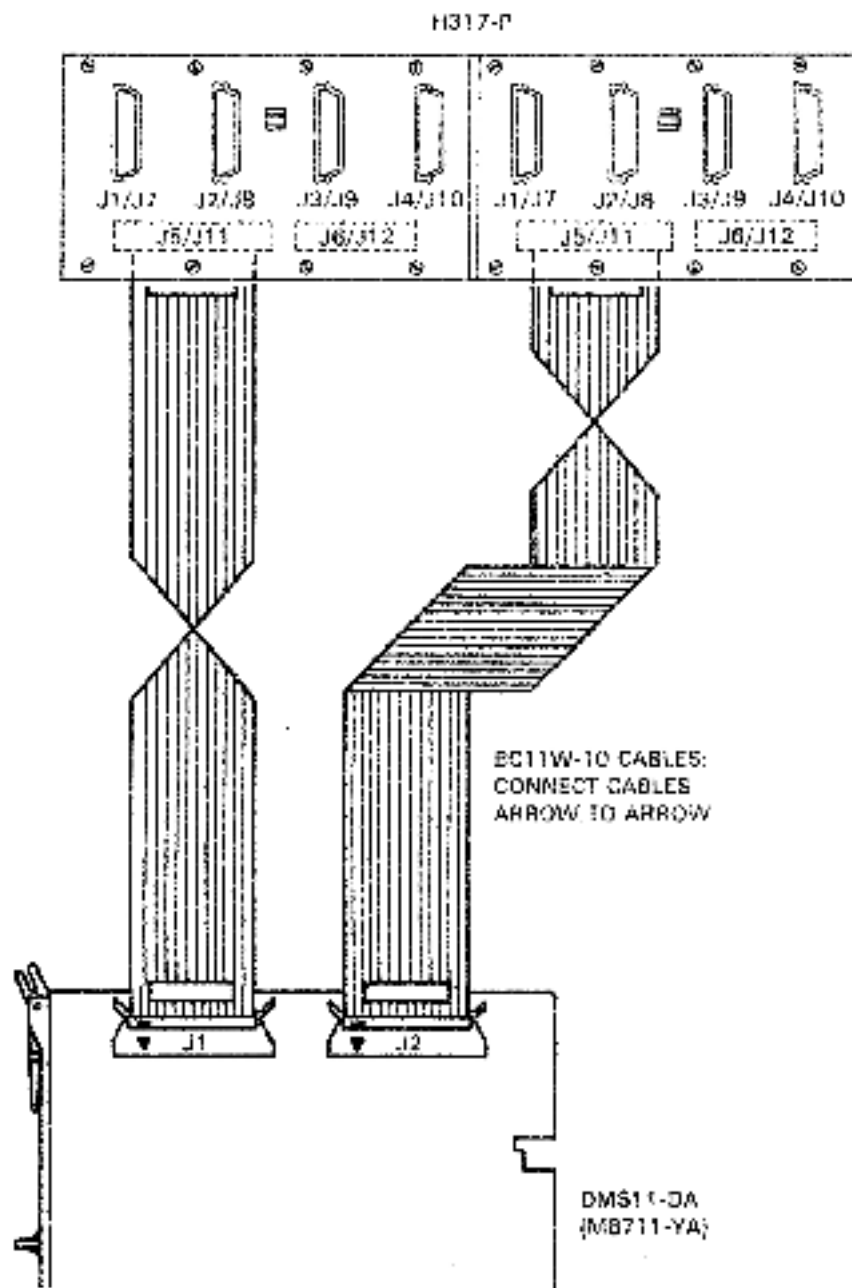

Figure 3-7 DMS11-DA (M8704) Line Unit to H317-P Distribution Panel Cabling

### 3.3.6 DMS11-DA (M8711-YA) Line Unit Cabling to an H317-P Distribution Panel

When configuring the DMS11-DA synchronous line unit, two BC11W-10 cables are used. To configure the DMS11-DA line unit to the H317-P distribution panel, connect the cables as shown in Figure 3-8.



46-475

Figure 3-8 DMS11-DA (M8711-YA) Line Unit to H317-P Distribution Panel Cabling

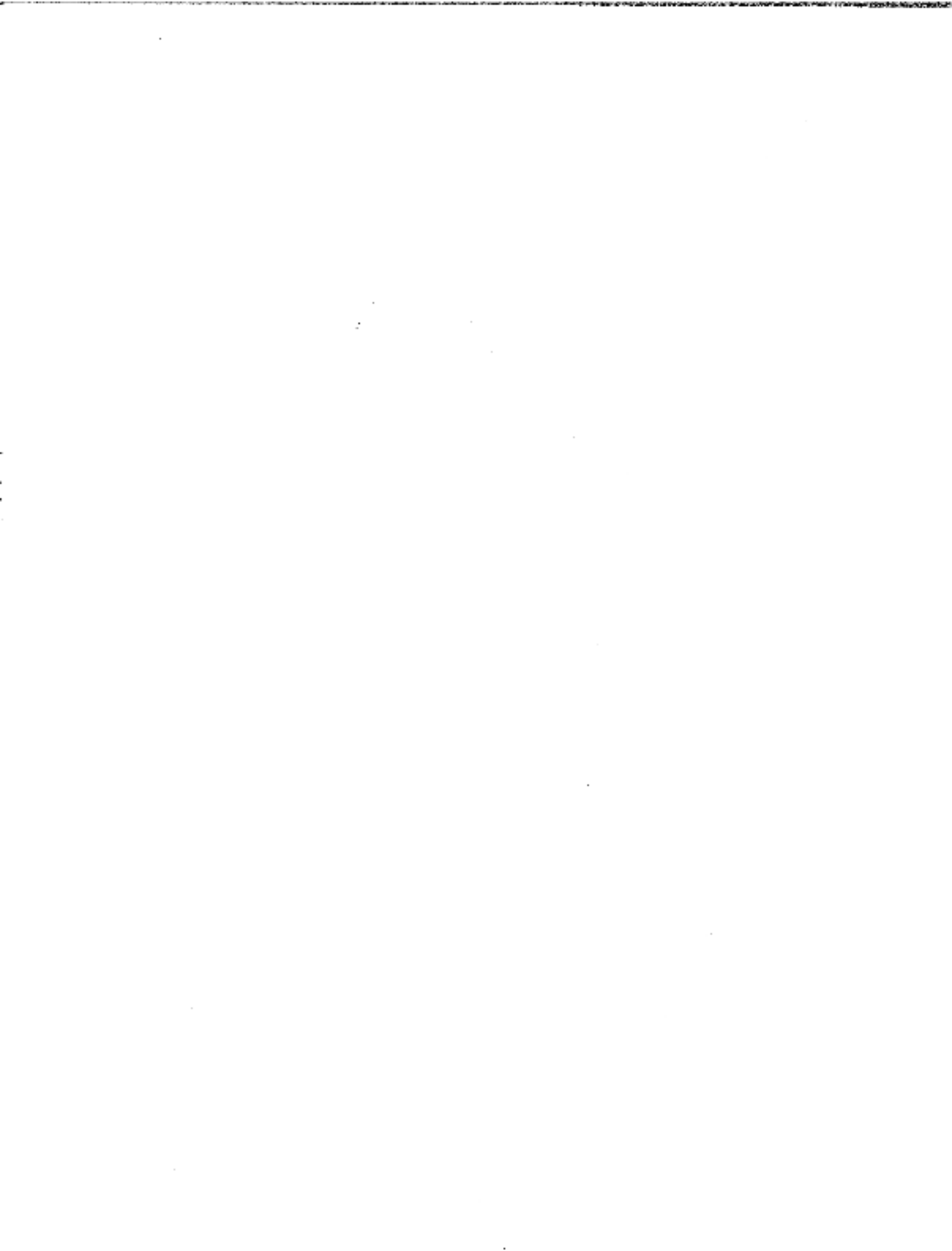

## CHAPTER 4 MAINTENANCE

### 4.1 INTRODUCTION

This chapter will aid the user in performing limited maintenance on the KMS11-BD/BE synchronous communications processor. This chapter is not intended to give the user a complete listing of troubles and their solutions. Instead, it will assist the user in determining which diagnostics to use when checking the KMS11-BD/BE communications processor.

### 4.2 MAINTENANCE PHILOSOPHY

Since the KMS11-BD/BE communications processor is a complex, high-speed, intelligent communications interface that is densely packaged and mounted in the DD11-DK nine-slot backplane, maintenance to be performed on the unit is limited to the running of diagnostics.

Should a failure occur while running diagnostics, call field service. *Field repair of the KMS11-BD/BE communications processor is not to be attempted under any circumstances.*

### 4.3 SPECIAL TOOLS AND EQUIPMENT

There are no special tools or special equipment needed to perform user maintenance on the KMS11-BD/BE communications processor.

### 4.4 PDP-11 SYSTEM DIAGNOSTIC SOFTWARE

This section lists the diagnostic software that is used to verify proper operation of the KMS11-BD/BE communications processor when interfaced to a PDP-11 system. Also contained in this section is a basic description of the diagnostic tests and the sequence in which the diagnostics are to be run.

The diagnostics used are:

- CZKMB (YM-Z093D-A) - Section 4.4.1
- CZKMC (YM-Z093D-B) - Section 4.4.2
- CZKMD (YM-Z136D-1) - Section 4.4.3
- CZKME (YM-Z136D-2) - Section 4.4.4
- CZKMG (YM-Z138D-A) - Section 4.4.5
- CZKMF (YM-Z136D-3) - Section 4.4.6
- CXKMA (YM-Z093D-X) - Section 4.4.7
- CXDMS (YM-Z138D-X) - Section 4.4.8

#### 4.4.1 CZKMB (YM-Z093D-A)

The CZKMB is the *first* diagnostic run when testing the KMS11-BD/BE synchronous communications processor. This diagnostic should be run in conjunction with CZKMC in order to test the logic circuits on the KMC11-B general purpose UNIBUS microprocessor. In order for the KMC11-B microprocessor to pass this diagnostic, a minimum of 10 consecutive error-free passes must be run.

The CZKMB diagnostic tests from 1 to 64 KMC11-B microprocessor modules. The CZKMB diagnostic runs under the diagnostic run-time services (DRS). CZKMB consists of sequential logic tests that are used to verify most of the KMC11-B microprocessor logic circuits.

##### *Equipment Requirements*

- A PDP-11 microprocessor with at least 16K of memory,
- A console device (such as an LA36, LA120, LA34, or VT100), and
- A KMC11-B general purpose UNIBUS microprocessor.

#### 4.4.2 CZKMC (YM-Z093D-B)

CZKMC is the *second* diagnostic run when testing the KMS11-BD/BE synchronous communications processor.

The CZKMC diagnostic tests from 1 to 64 KMC11-B microprocessor modules. It runs under the diagnostic run-time services (DRS) and consists of a set of sequential logic tests used to verify the logic circuits of a KMC11-B microprocessor. The CZKMC is run after and in conjunction with diagnostic CZKMB. CZKMB and CZKMC verify proper operation of all KMC11-B microprocessor logic circuits.

##### *Equipment Requirements*

- A PDP-11 microprocessor with at least 16K of memory,
- A console device (such as an LA36, LA120, LA34, or VT100), and
- A KMC11-B general purpose UNIBUS microprocessor.

#### 4.4.3 CZKMD (YM-Z136D-1)

CZKMD is the *third* diagnostic run when testing the KMS11-BD/BE synchronous communication processor.

The CZKMD diagnostic tests the line unit for both character-control protocol (CCP) and bit-oriented protocol (BOP) modes while in either the USYRT maintenance mode or external mode. This CZKMD diagnostic exercises the line unit without resident firmware in the KMC11-B UNIBUS microprocessor.

##### *Equipment Requirements*

- A PDP-11 microprocessor,
- A console device (such as an LA36, LA120, LA34, or VT100),
- A KMC11-B general purpose UNIBUS microprocessor,
- Either a 2M-E044A or 54-14698 test connector, and
- A DMS11-D line unit.

#### 4.4.4 CZKME (YM-Z136D-2)

CZKME is the *fourth* diagnostic run when testing the KMS11-BD/BE synchronous communication processor.

The CZKME diagnostic tests the line unit in either bit-oriented protocol (BOP) or character-control protocol (CCP) mode using internal USYRT maintenance mode or external loopback connectors. These options are selected by responses to questions asked by the diagnostic during startup or by entering the configuration mode. The CZKME diagnostic is a stand-alone routine which tests the line unit with resident firmware in the KMC11-B general purpose UNIBUS microprocessor.

##### *Equipment Requirements*

- A PDP-11 microprocessor,
- A console device (such as an LA36, LA120, LA34, or VT100),
- A KMC11-B general purpose UNIBUS microprocessor,
- Either a 2M-E044A or 54-14698 test connector, and
- A DMS11-DA line unit.

#### 4.4.5 CZKMG (YM-Z138D-A)

CZKMG is the *fifth* diagnostic run when testing the KMS11-BD/BE synchronous communications processor.

CZKMG tests the DM11-BA modem control multiplexer. The CZKMG diagnostic is functionally divided into the following groups:

- *Group 0* - All line scanner and line multiplexer functions are tested using either the H317-M or H317-P distribution panel with H3256 test connectors in place of the modem cables or with 54-14700 or 2M-E122A loopback connectors.
- *Group 1* - A single line is tested using either the H317-M or H317-P distribution panel with H3256 test connectors in place of the modem cables or with 54-14700 or 2M-E122A loopback connectors.
- *Group 2* - Not applicable.
- *Group 3* - Connect/disconnect test for 202C compatible modems.

##### *Equipment Requirements*

- A PDP-11 microprocessor with at least 8K of memory,
- A console device (such as an LA36, LA120, LA34 or VT100),
- A DM11-BA modem control multiplexer,
- Either an H317-M or H317-P distribution panel, and
- A 54-14700, 2M-E122A, or H3256 test connectors.

#### 4.4.6 CZKMF (YM-Z136D-3)

CZKMF is the *sixth* diagnostic run when testing the KMS11-BD/BE synchronous communications processor.

The CZKMF diagnostic tests the interaction between the DMS11-DA communications controller and the DM11-BA modem control multiplexer. The CZKMF diagnostic is functionally divided in the following groups:

- *Group 0* - All line scanner and line multiplexer function tests use the H3256 test connectors with either the H317-M or H317-P distribution panel.
- *Group 1* - A single line is tested using either the H317-M or H317-P distribution panel with the H3256 test connectors in place of the modem cables.

#### *Equipment Requirements*

- A PDP-11 microprocessor with at least 12K of memory.
- A console device (such as an LA36, LA120, LA34, or VT100).
- A DM11-BA modem control multiplexer.
- A DMS11-DA line unit.
- A KMS11-BD synchronous communication processor, and
- A 54-14700/2M-E122A and 54-14698/2M-E044A or a H3256 test connector.

#### 4.4.7 CXKMA (YM-A093D-X)

CXKMA is the *seventh* diagnostic run when testing the KMS11-BD/BE synchronous communications processor.

The CXKMA DEC/X11 module exercises up to two consecutively addressed and consequently vectored KMC11-B microprocessors. CXKMA does not use any line units for receiving and transmitting data. The data is transmitted and received from the PDP-11 system memory to the KMC11-B microprocessor and vice versa.

#### *Equipment Requirements*

- A KMC11-B general purpose UNIBUS microprocessor.

#### 4.4.8 CXDMS (YM-Z138D-X)

CXDMS is the *eighth* diagnostic run when testing the KMS11-BD/BE synchronous communications processor.

The CXDMS DEC/X11 module exercises up to four DM11-BA multiplexer modules. CXDMS utilizes maintenance mode and scan enable to fully test the scan logic. This test is performed either by using the H3256 test connector at the distribution panel or by placing either the 2M-E044A test connector or the 54-14700 test connector on the module.

#### *Equipment Requirements*

- A DM11-BA modem control multiplexer.

#### 4.5 PDP-11 SYSTEM DIAGNOSTIC LISTINGS

For easy reference, refer to Table 4-1 for the different diagnostic listing numbers.

#### 4.6 VAX-11 SYSTEM DIAGNOSTIC SOFTWARE

This section lists the diagnostic software that is used to verify proper operation of the KMS11-BD/BE communications processor when interfaced to a VAX-11 system. Also contained in this section is a basic description of the diagnostic tests and the sequence in which the diagnostics are to be run.

The diagnostics used are:

- ZZ-EVDHA - Section 4.6.1
- ZZ-EVDKA - Section 4.6.2
- ZZ-EVDJA - Section 4.6.3
- ZZ-EVDIA - Section 4.6.4
- ZZ-EVDHB - Section 4.6.5
- ZZ-EVDIB - Section 4.6.6

##### 4.6.1 ZZ-EVDHA

ZZ-EVDHA is the first diagnostic run when testing the KMS11-BD/BE synchronous communications processor.

Table 4-1 PDP-11 System Diagnostics

Device	Diagnostic	Diagnostic Listing Number
KMS11-BD Processor	CZKMF (YM-Z136D-3)	AC-S887A-MC
KMC11-B Microprocessor	CXKMA (YM-Z093D-X)	AC-S904A-MC
	CZKMB (YM-Z093D-A)	AC-S875A-MC
	CZKMC (YM-Z093D-B)	AC-S878A-MC
DMS11-DA Line Unit	CZKMD (YM-Z136D-1)	AC-S881A-MC
	CZKME (YM-Z136D-2)	AC-S884A-MC
DM11-BA Multiplexer	CXDMS (YM-Z138D-X)	AC-S902A-MC
	CZKMG (YM-Z138D-A)	AS-S890A-MC

The ZZ-EVDHA diagnostic contains 20 tests which establish the functionality of the KMC11-B microprocessor. All pertinent bits are tested for their ability to be set and then cleared. All registers and memory locations are tested to verify that they can be accessed and that they do retain the data placed into them. Where necessary, all registers and memory locations are checked to verify that no two addresses or registers answer to the same address. The arithmetic logic unit (ALU) is tested, first with the ALU carry bit cleared and then with ALU carry bit set. The entire board is then tested where all pertinent register/memory addresses are accessed together and a verification is made that all internal data paths are functioning correctly.

#### *Equipment Requirements*

- A VAX-11 microprocessor with at least 128K of memory,
- A KMC11-B microprocessor, and
- A UNIBUS connector adapter.

#### **4.6.2 ZZ-EVDKA**

ZZ-EVDKA is the *second* diagnostic run when testing the KMS11-BD/BE synchronous communications processor.

The ZZ-EVDKA is the DMS11-DA line unit repair level (level 3) diagnostic. The ZZ-EVDKA diagnostic tests one to eight lines in a closed loop environment. The line unit is driven by the KMC11-B UNIBUS microprocessor without resident firmware. The DMS11-DA line unit should be tested using the AA-EVDKA diagnostic before any dynamic KMS11-BD communications processor testing is performed.

#### *Equipment Requirements*

- A VAX-11 microprocessor with at least 128K of memory,
- A KMC11-B microprocessor,
- A DMS11-DA line unit, and
- A UNIBUS connector adaptor.

#### **4.6.3 ZZ-EVDJA**

ZZ-EVDJA is the *third* diagnostic run when testing the KMS11-BD/BE synchronous communications processor.

ZZ-EVDJA is the DM11-BA modem control multiplexer repair level (level 3) diagnostic. The ZZ-EVDJA is a component of the KMS11-BD communications processor option, but it can be tested independently, using only the H317-M distribution panel. The diagnostic is divided into the following functional tests:

- *Default Section* - All line scanner and line multiplexer functions are tested using the H317-M test connectors with either the H317-M or H317-P distribution panel.
- *H3256 Section* - A single line is tested using the H317-M or H317-P distribution panel with H3256 test connectors in place of the modem cables.

#### *Equipment Requirements*

- A VAX-11 microprocessor at ECO level #3 or above and with at least 128K memory,
- A DM11-BA multiplexer.

- Either an H317-M or H317-P distribution panel,
- One to eight H317-M test connectors, and
- A UNIBUS connector adaptor.

#### 4.6.4 ZZ-EVDIA

ZZ-EVDIA is the *fourth* diagnostic run when testing the KMS11-BD/BE synchronous communications processor.

ZZ-EVDIA checks the functionality of a KMC11-B microprocessor interfaced to a DMS11-DA line unit. The operator may select from one to eight lines on the DMS11-DA line unit to be tested. ZZ-EVDIA provides error messages which identify failing functions which aid in the repair of the device. The ZZ-EVDIA diagnostic uses loopback to test data thru-put facilities. The loopback is internal to the DMS11-DA line unit unless the operator selects to use external mode. ZZ-EVDIA stores, loads, and tests separate KMC11-B microprocessor firmware protocols.

##### *Equipment Requirements*

- A VAX-11 microprocessor with at least 128K of memory,
- A UNIBUS connector adaptor,
- A KMC11-B microprocessor,
- A DMS11-DA line unit,
- Either an H317-M or H317-P distribution panel, and
- Either a 54-14698 or 2M-E122A loopback and a connector (required for external loopback only).

#### 4.6.5 ZZ-EVDHB

ZZ-EVDHB is the *fifth* diagnostic run when testing the KMS11-BD/BE synchronous communications processor.

ZZ-EVDHB tests the functionality of the KMC11-B microprocessor in a VMS environment. Special diagnostic firmware is loaded into the KMC11-B microprocessor and used to transmit, receive, and check data buffers of 512 characters. One pass is defined as 128 interactions of the sequence.

##### *Equipment Requirements*

- A VAX-11 microprocessor with at least 128K of memory,
- A UNIBUS connector adaptor, and
- A KMC11-B general purpose UNIBUS microprocessor.

#### 4.6.6 ZZ-EVDIB

ZZ-EVDIB is the *sixth* diagnostic run when testing the KMS11-BD/BE synchronous communications processor.

The ZZ-EVDIB tests the functionality of the KMC11-B microprocessor interfaced to a DMS11-DA line unit. The operator may select from one to eight lines on the KMS11-BD processor to be tested. ZZ-EVDIB

provides error messages which identify failing functions. This aids in the repair of the device. ZZ-EVD1B uses loopback to test transmit and receive data integrity. The loopback is internal to the KMS11-BD communications processor unless the operator selects external mode. EVD1B stores, loads, and tests two separate KMC11-B microprocessor firmware protocols.

#### *Equipment Requirements*

- A VAX-11 microprocessor with at least 128K of memory,
- A UNIBUS connector adaptor,
- A KMC11-B UNIBUS microprocessor,
- A DMS11-DA eight-line synchronous line unit, and
- An H317-M loopback connector (required for external loopback only).

#### **4.7 VAX-11 SYSTEM DIAGNOSTIC LISTINGS**

For easy reference, refer to Table 4-2 for the different diagnostic listing numbers.

**Table 4-2 VAX-11 System Diagnostics**

<b>Device</b>	<b>Diagnostic</b>	<b>Diagnostic Listing Number</b>
KMC11-B Microprocessor	ZZ-EVDHA*	ZZ-EVDHA
	ZZ-EVDHB*	ZZ-EVDHB
	ZZ-EVDKA	ZZ-EVDKA
	ZZ-EVDIA	ZZ-EVDIA
	ZZ-EVDIB	ZZ-EVDIB
DMS11-DA Line Unit	ZZ-EVDKA	ZZ-EVDKA
	ZZ-EVDIA	ZZ-EVDIA
	ZZ-EVDIB	ZZ-EVDIB
DM11-BA Multiplexer	ZZ-EVDJA	ZZ-EVDJA

\* This diagnostic is for the KMC11-B microprocessor only.

## CHAPTER 5 FIELD REPLACEABLE UNITS

### 5.1 INTRODUCTION

This chapter lists the Digital Equipment Corporation part numbers for the major components of the KMS11-BD/BE synchronous communications processor. The chapter is divided into the following sections:

- Boards (Section 5.2)
- Test connectors (Section 5.3)
- Cables (Section 5.4)
- Assemblies (Section 5.5)

### 5.2 BOARDS

Description	Part Number
KMC11-B UNIBUS microprocessor	M8206
DM11-BA modem control multiplexer	M8640
DMS11-DA 8-line synchronous line unit	M8704*
Priority five (5) interrupt card	5408778
Priority four (4) interrupt card	5408776

### 5.3 TEST CONNECTORS

Description	Part Number
H317-M distribution panel test connector	H3256
DMS11-DA line unit test connector	2M-E044A†
DMS11-DA line unit test connector	54-14698‡
DM11-BA multiplexer test connector	2M-E122A
DM11-BA multiplexer test connector	54-14700

### 5.4 CABLES

Description	Part Number
3.05 m (10.00 ft), 50-conductor, shielded cable	BC31W-10

\* M8704 supersedes M8711-YA.

† This test connector can be used on the M8704 and must be used on the M8711 or M8711-YA.

‡ When this number is ordered, either two 2M-E044A or two 54-14698 test connectors will be shipped.

3.05 m (10.00 ft), 40-conductor, shielded cable (reverse configuration)

BC08R-10

3.05 m (10.00 ft), 40-conductor, unshielded cable (reverse configuration)

BC08R-01

## 5.5 ASSEMBLIES

### Description

### Part Number

Distribution panel

H317-M or H317-F





Your comments and suggestions will help us in our continuous effort to improve the quality and usefulness of our publications.

What is your general reaction to this manual? In your judgement is it complete, accurate, well organized, well written, etc? Is it easy to use? \_\_\_\_\_  
\_\_\_\_\_  
\_\_\_\_\_

What features are most useful? \_\_\_\_\_  
\_\_\_\_\_  
\_\_\_\_\_

What faults or errors have you found in the manual? \_\_\_\_\_  
\_\_\_\_\_  
\_\_\_\_\_

Does this manual satisfy the need you think it was intended to satisfy? \_\_\_\_\_

Does it satisfy your needs? \_\_\_\_\_ Why? \_\_\_\_\_  
\_\_\_\_\_  
\_\_\_\_\_

Please send me the current copy of the *Technical Documentation Catalog*, which contains information on the remainder of DIGITAL's technical documentation.

Name \_\_\_\_\_ Street \_\_\_\_\_  
Title \_\_\_\_\_ City \_\_\_\_\_  
Company \_\_\_\_\_ State/Country \_\_\_\_\_  
Department \_\_\_\_\_ Zip \_\_\_\_\_

Additional copies of this document are available from:

Digital Equipment Corporation  
444 Whitney Street  
Northboro, MA 01532

Attention: Printing and Circulation Services (NR2/M15)  
Customer Services Section

Order No. EK-KMSBE-UG-001

Fold Here

Do Not Tear - Fold Here and Staple -

**digital**



No Postage  
Necessary  
if Mailed in the  
United States

**BUSINESS REPLY MAIL**

FIRST CLASS PERMIT NO. 33 MAYNARD, MA

POSTAGE WILL BE PAID BY ADDRESSEE

Digital Equipment Corporation  
Educational Services/Quality Assurance  
12 Crosby Drive, BU/E08  
Bedford, MA 01730





