

CODE MA D-8-0-1 REV. LTR. A

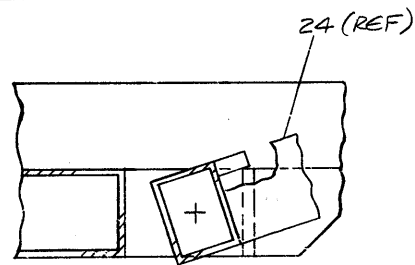

SECTION B-B
SCALE: 1/1

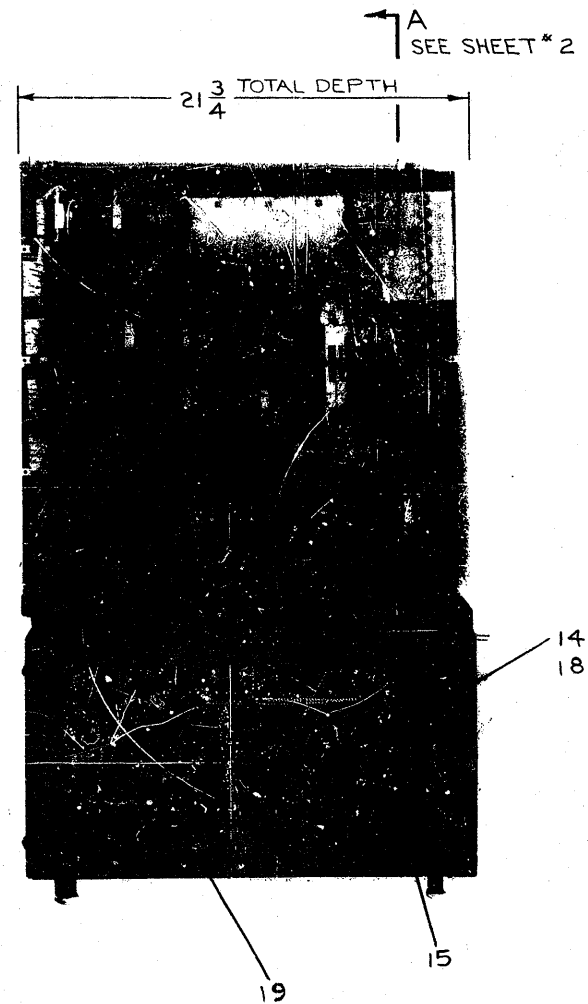
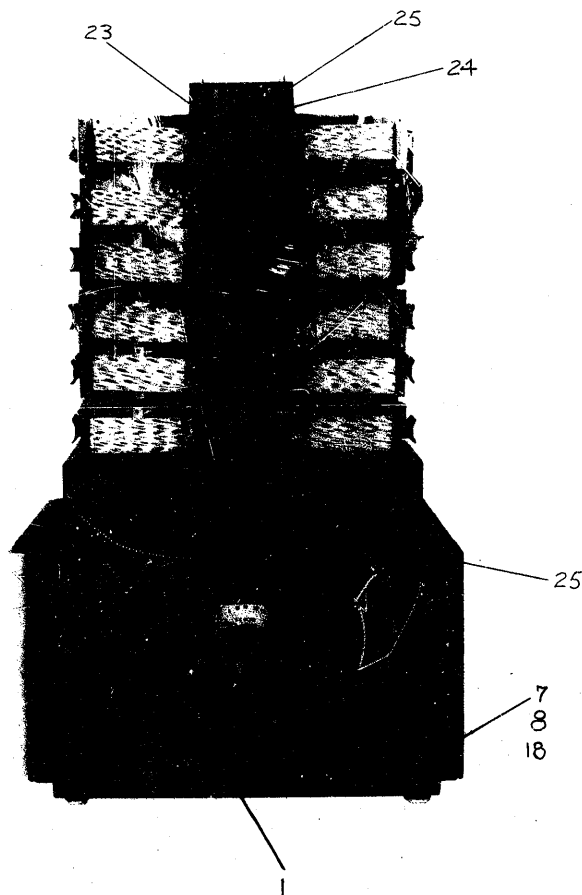
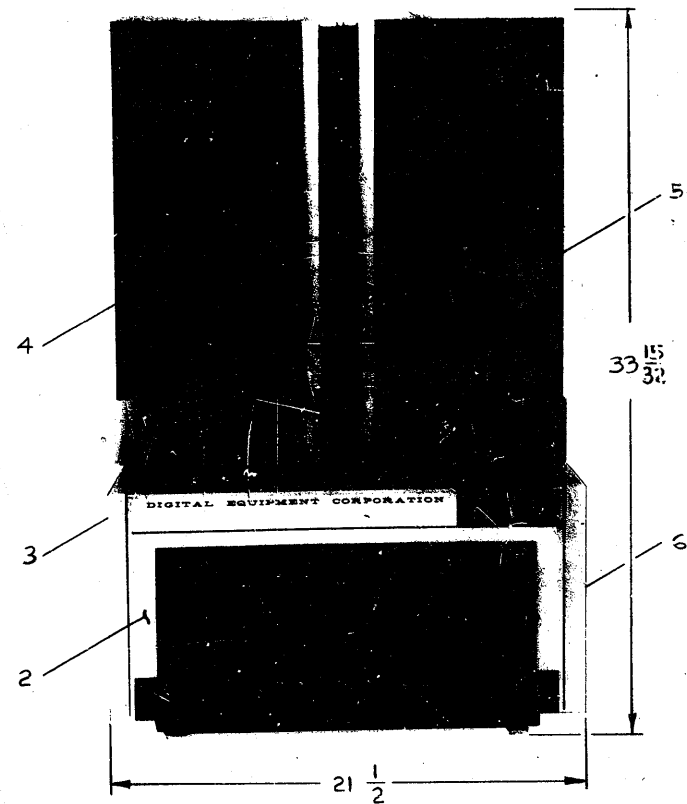

A
SEE SHEET # 2

NOTES:

| | | |
|---|-----------------|--------------------|
| * INDICATES OPTION | | |
| NYLON WASHER 5/16 I.D. X 7/8 O.D. X 1/16 THK | | 25 |
| 1 HINGED DOOR (LEFT) | MA-E-8-0-24 | 24 |
| 1 HINGED DOOR (RIGHT) | MA-D-8-0-23 | 23 |
| 1 HANDLE (LEFT) | MD-C-8-1-23-0-3 | 22 |
| 1 HANDLE (RIGHT) | MD-C-8-0-23-0-3 | 21 |
| 6 PHILLIPS FLAT HD. MACH. SCREW # 10-32 X 5/8 LG. SST. | | 20 |
| 1 PDP-8 SUB ASSY | A-PL-8-0-1-4 | 19 |
| 10 INTERNAL TOOTH LOCK WASHER #10 HOLE | | 18 |
| 4 INTERNAL TOOTH LOCK WASHER #6 HOLE | | 17 |
| 1 WINGED TABLE ASSY. (FLOOR MODEL) | MA-D-8-0-45 | 16 |
| 1 AIR FILTER 7/16 THK. 17 9/16 SQUARE PHILLIPS TRUSS HEAD MACH. SCREW #10-32 X 1 3/8 LG. SST. | | 15 |
| 4 | | 14 |
| 1 UPPER FRAME | MA-E-8-0-20 | 13 |
| PHILLIPS PAN HEAD MACH. SCREW #10-32 X 3/8 LG. SST. | | 12 |
| 4 WASHER 5/32 I.D. X 1/4 O.D. X 1/16 THK | | 11 |
| 4 | | 10 |
| 1 LOWER FRAME WELDMENT | MMA-E-8-C-1-1 | 9 |
| 6 PHILLIPS TRUSS HEAD MACH. SCREW #10-32 X 5/8 LG. SST. | | 8 |
| 1 708 POWER SUPPLY | MA-D-708-0-1 | 7 |
| 1 SIDE COVER (RIGHT) | MAD-D-8-0-42 | 6 |
| 1 TOP COVER (RIGHT) | MD-E-8-0-1-0-1 | 5 |
| 1 TOP COVER (LEFT) | MD-E-8-0-1-0-2 | 4 |
| 1 SIDE COVER (LEFT) | MAD-D-8-0-43 | 3 |
| 1 CONTROL PANEL | HA-E-8-0-21 | 2 |
| 1 FILTER COVER PANEL | MD-B-8-0-1-0-3 | 1 |
| QTY. | DESCRIPTION | DRWG. NO. ITEM NO. |

| REV. LTR. | DESCRIPTION |
|-----------|---|
| A | * 2672 EXT. CHGS. SEE PREV. REV. 7-7-66 |

| HOLE LEGEND | | | |
|-------------|-----|------|-----|
| SIZE | QTY | SIZE | QTY |
| G | | A | |
| H | | B | |
| J | | C | |
| K | | D | |
| L | | E | |
| M | | F | |

| | | |
|----------------------------------|----------------|--------------|
| UNLESS OTHERWISE SPECIFIED | | |
| GRINDING-IRRESPECTIVE OF THE LAY | | |
| MICROINCHES | | |
| TOLERANCES | | |
| FRACTIONS ±1/64 | DECIMALS ±.005 | ANGLES ±1/2° |
| MATERIAL | | |
| ROCKWELL | | |
| SURF TREAT | | |

| FINISH (AFTER FABRICATION) | DATE |
|----------------------------|---------|
| STEP 1 | 4/15/65 |
| STEP 2 | 4/15/65 |
| STEP 3 | 4-16 |
| STEP 4 | 4-16 |
| STEP 5 | 4-16 |
| STEP 6 | 4-16 |

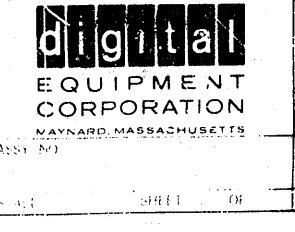

| | | |
|-------------------|-----------|-----------|
| TITLE | | |
| PDP-8 TABLE MODEL | | |
| FOR | | |
| CODE | DRWG. NO. | REV. LTR. |
| | MAD-8-0-1 | A |
| DIST. | | |

CODE MA DRWG. NO. D-8-0-1 REV. LTR. A

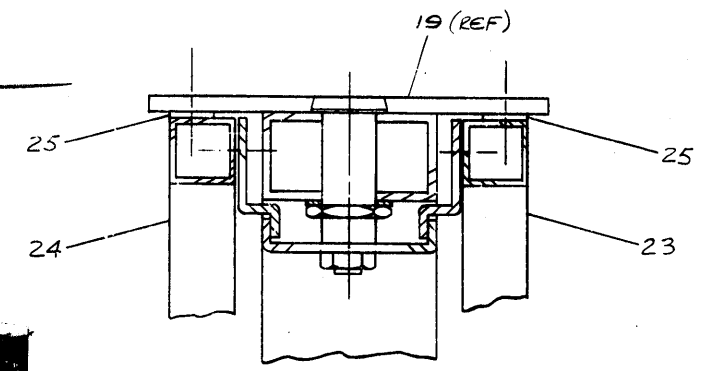
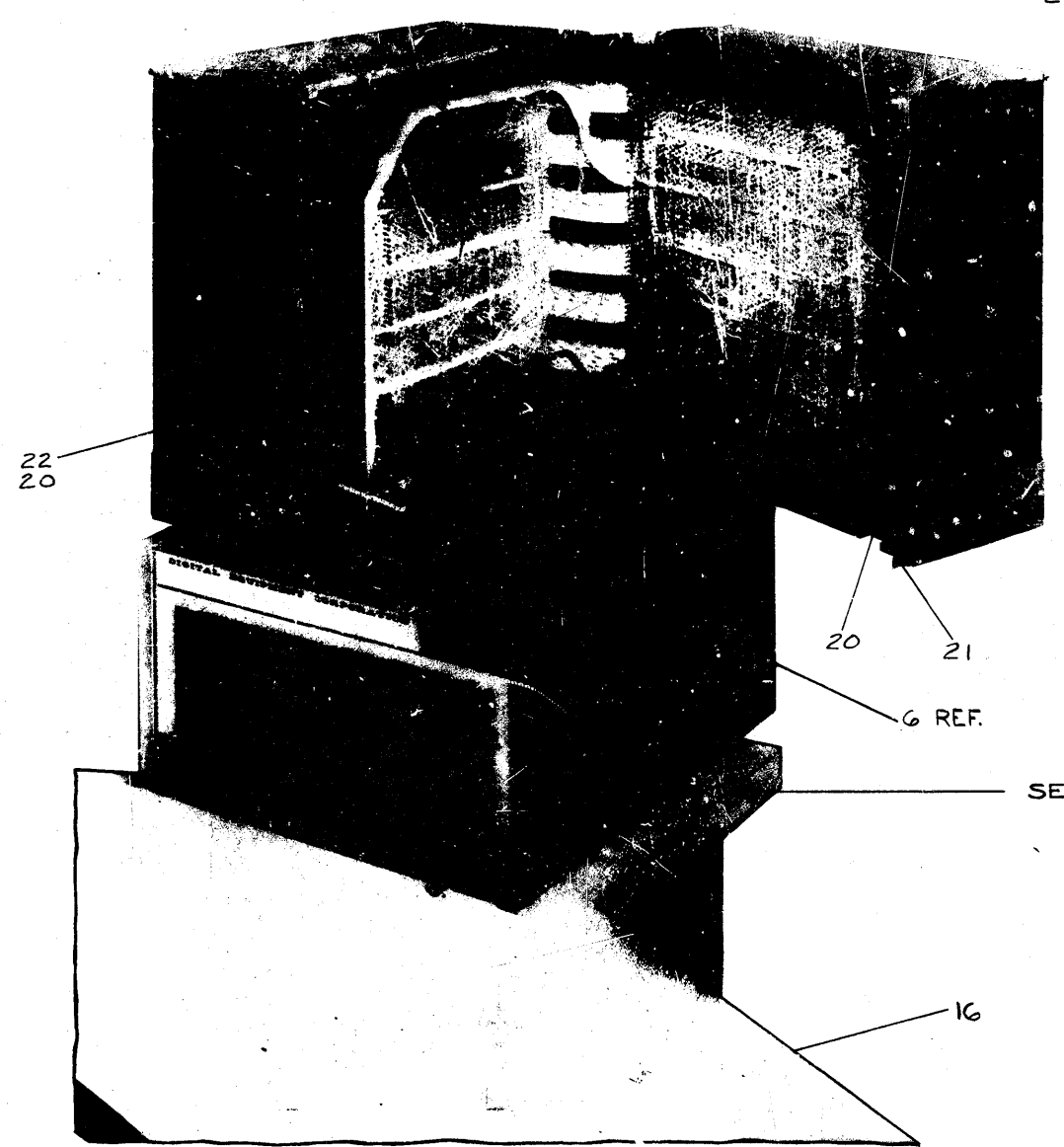

SECTION A-A
SCALE: 1/1

NOTES:
1. TABLE HEIGHT TO BE 26 3/4 FROM FLOOR

SEE NOTE 1

| | |
|-----------|---------------------------|
| REV. LTR. | A |
| REVISIONS | #2672 SEE SHEET #1 7-7-66 |
| CHK | |

| HOLE LEGEND | | | |
|-------------|------|-----|---|
| | SIZE | QTY | |
| G | | | A |
| H | | | B |
| J | | | C |
| K | | | D |
| L | | | E |
| M | | | F |

UNLESS OTHERWISE SPECIFIED
GRINDING-IRRESPECTIVE OF THE LAY ✓
MICROINCHES
TOLERANCES
FRACTIONS ± 1/64 DECIMALS ± .008 ANGLES ± 1/2°
MATERIAL
ROCKWELL SURF TREAT

| FINISH (AFTER FABRICATION) | |
|----------------------------|--|
| STEP 1 | |
| 2 | |
| 3 | |
| 4 | |
| 5 | |
| 6 | |

| | |
|----------|------|
| DRAWN | DATE |
| CHECKED | DATE |
| ENG | DATE |
| PROJ ENG | DATE |
| DATE | |

digital
EQUIPMENT CORPORATION
MAYNARD, MASSACHUSETTS

| | | | |
|-------|-----------|-------------------|---|
| TITLE | | PDP-8 TABLE MODEL | |
| FOR | | | |
| CODE | DRWG. NO. | REV LTR. | |
| MA | D-8-0-1 | A | |
| SCALE | SHEET OF | SWT. | 1 |

| | | | |
|-----|-------------|-----------|----------|
| QTY | DESCRIPTION | DRWG. NO. | ITEM NO. |
|-----|-------------|-----------|----------|

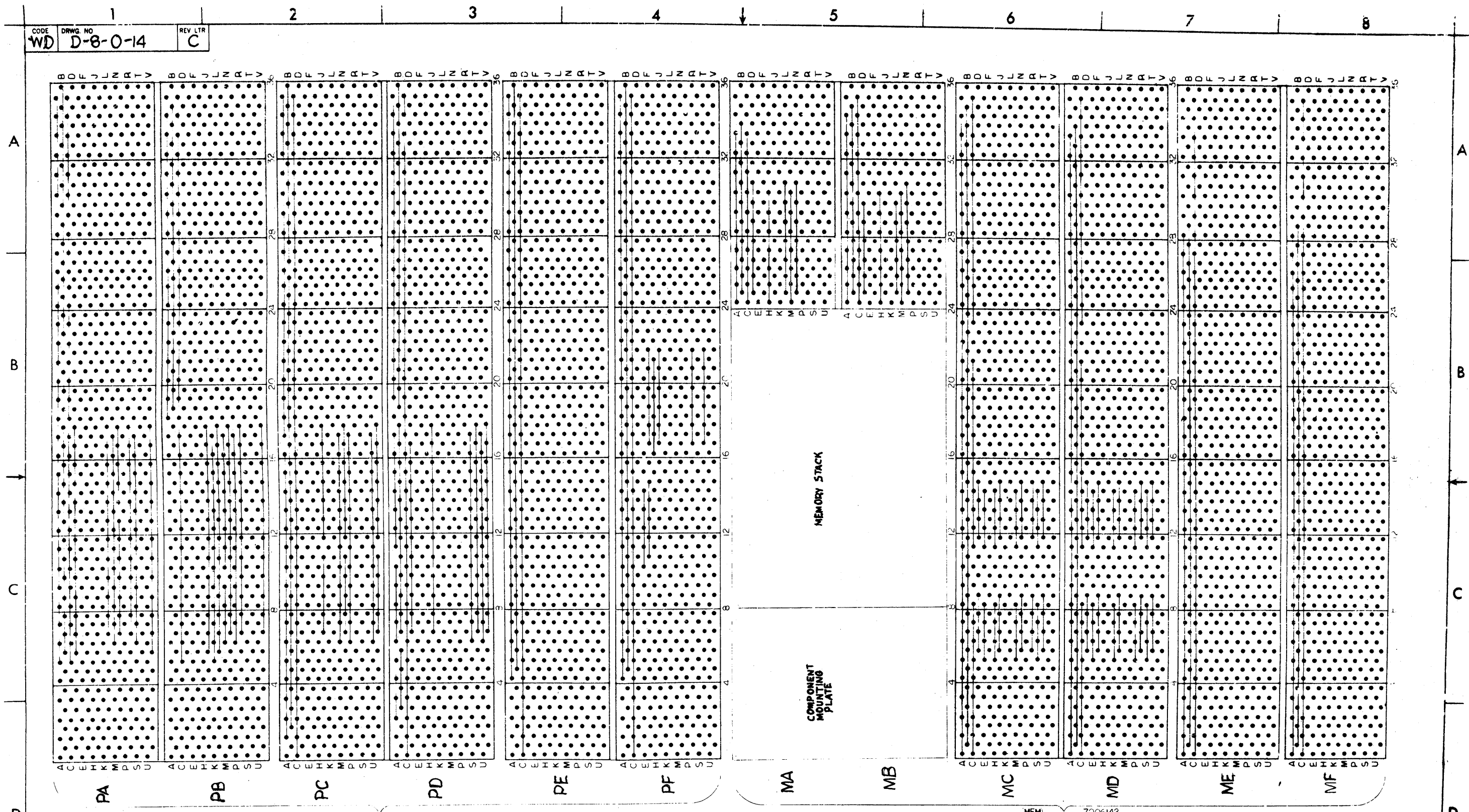

700643
(C.P.)

| | | | | | | |
|--------------|---------|-----------------|---------|--|--|-----------------|
| MEM. 7006142 | | DATE 10-5-64 | |  DIGITAL EQUIPMENT CORPORATION MAYNARD, MASSACHUSETTS | TITLE BUS BAR FOR POWER AND LOGIC WIRING | |
| DRW. DATE | 10-5-64 | CHECKED DATE | 10-5-64 | | FOR | |
| ENG. DATE | | PROJ. ENG. DATE | | ASSY. NO. | CODE | DRWG. NO. |
| PROG. DATE | | | | | WD | D-8-0-14 |
| REVISIONS | | | | SHEET | OF | REV. LTR. |
| REV. LTR. | NO. | DATE | ENG. | | | D |
| A | 1 | | | | | |
| B | 2 | | | | | |
| C | 3 | | | | | |
| D | 4 | | | | | |

This drawing and specifications, herein, are the property of Digital Equipment Corporation and shall not be reproduced or copied or used in whole or in part as the basis for the manufacture or sale of items without written permission.

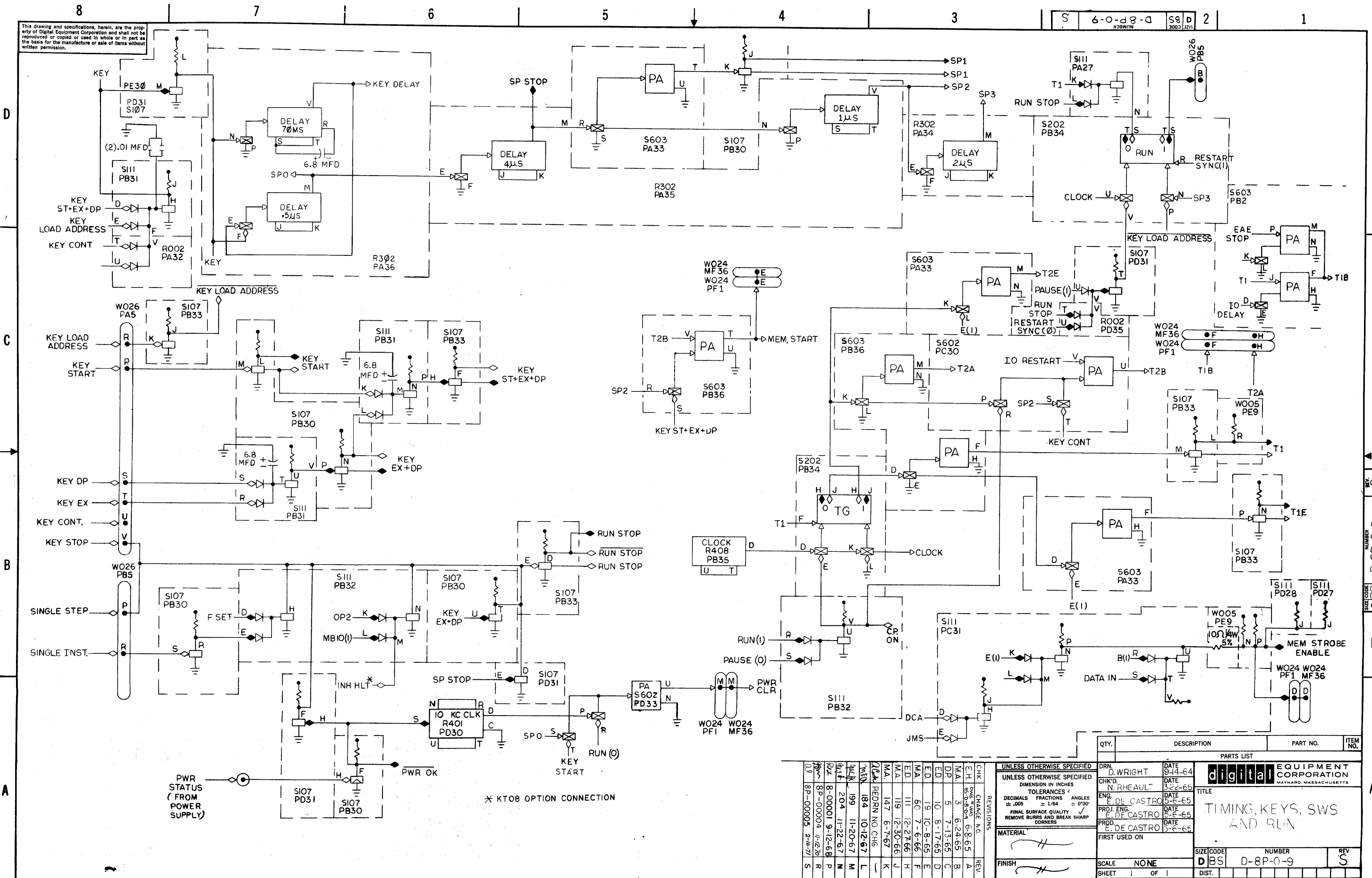

| QTY. | DESCRIPTION | PART NO. | ITEM NO. |
|------|--|----------|----------|
| | PARTS LIST | | |
| | digital EQUIPMENT CORPORATION MAYNARD, MASSACHUSETTS | | |
| | TITLE TIMING, KEYS, SWS AND RUN | | |
| | SIZE CODE D BS NUMBER D-8P-0-9 REV S | | |

| CHK | CHANGE NO. | REV |
|-----|------------|-----|
| MA | 1 | A |
| ED | 2 | B |
| ED | 3 | C |
| ED | 4 | D |
| ED | 5 | E |
| ED | 6 | F |
| ED | 7 | G |
| ED | 8 | H |
| ED | 9 | J |
| ED | 10 | K |
| ED | 11 | L |
| ED | 12 | M |
| ED | 13 | N |
| ED | 14 | P |
| ED | 15 | R |
| ED | 16 | S |

| UNLESS OTHERWISE SPECIFIED | DRN. | DATE |
|--------------------------------------|---------------|---------|
| DIMENSION IN INCHES | D. WRIGHT | 9-14-64 |
| TOLERANCES | N. RHEAULT | 3-22-65 |
| DECIMALS FRACTIONS ANGLES | E. DE CASTRO | 5-6-65 |
| ± .005 ± 1/64 ± 0°30' | PROJ. ENG. | 5-6-65 |
| FINAL SURFACE QUALITY | E. DE CASTRO | 5-6-65 |
| REMOVE BURRS AND BREAK SHARP CORNERS | PROD. | 5-6-65 |
| MATERIAL | FIRST USED ON | |
| FINISH | SCALE | NONE |
| | SHEET | OF |

REV. S
NUMBER D-8P-0-9
SIZE CODE D BS

This drawing and specifications, herein, are the property of Digital Equipment Corporation and shall not be reproduced or copied or used in whole or in part as the basis for the manufacture or sale of items without written permission.

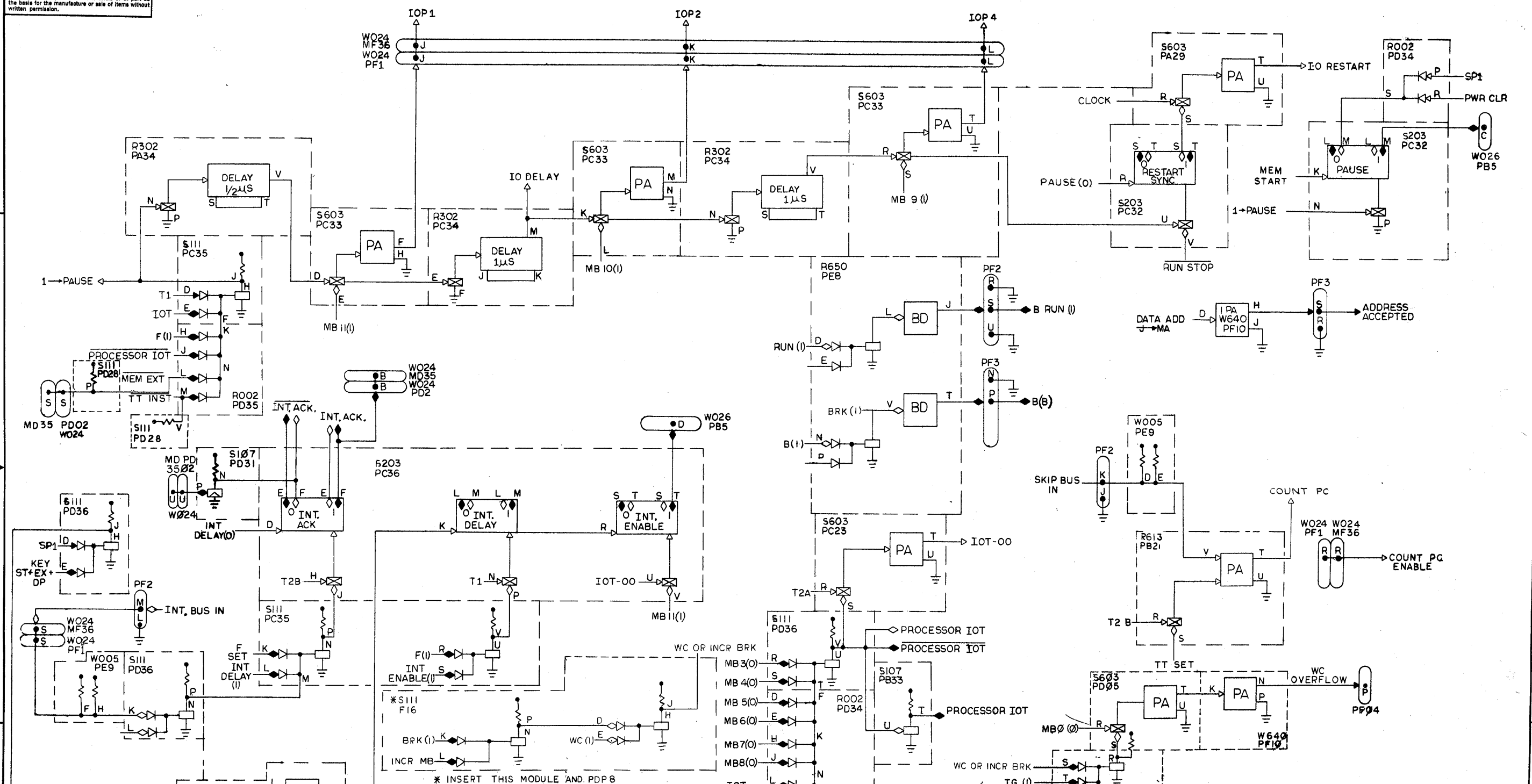

| QTY. | | DESCRIPTION | PART NO. | ITEM NO. | | | | | | | | | | | | | | | | | | | | | | | | | | | | | | | | | | | | | | | | | | | | | | | | | | | | | | | | | | | | | | | | | | | | | | | | | | | | | | | | | | | | | | | | | | | | | | | | | | | | | | | | | | | | | | | | | | | | | | | | | | | | | | | | |
|---|--------------|---|-----------------------------|----------|----------------|--------------|---|-----------------------------|--|----------------|--------------|-------------------|-------------|-------------------------|-------------|--------------------|-------------|---------------|--|--|--|--|------------|--|--|--|--|--------------|--|--|--|--|--------|--|--|--|--|----------|--|--|--|--|----------------------------|--|--|--|--|----------------------------|--|--|--|--|---------------------|--|--|--|--|------------|--|--|--|--|---------------------------|--|--|--|--|----------------------|--|--|--|--|-----------------------|--|--|--|--|--------------------------------------|--|--|--|--|-----------|--|--|--|--|------|-----|------|--|--|---|---|---------|--|--|---|---|---------|--|--|---|---|---------|--|--|---|---|----------|--|--|---|---|---------|--|--|---|---|--------|--|--|---|---|---------|--|--|---|---|--|--|--|
| PARTS LIST | | | | | | | | | | | | | | | | | | | | | | | | | | | | | | | | | | | | | | | | | | | | | | | | | | | | | | | | | | | | | | | | | | | | | | | | | | | | | | | | | | | | | | | | | | | | | | | | | | | | | | | | | | | | | | | | | | | | | | | | | | | | | | | | | | | | |
| <table border="1"> <tr> <td>DRN. D. WRIGHT</td> <td>DATE 9-22-64</td> <td rowspan="5" style="text-align: center; vertical-align: middle;"> digital EQUIPMENT CORPORATION <small>MAYNARD, MASSACHUSETTS</small> </td> <td colspan="2" rowspan="5" style="text-align: center; vertical-align: middle;"> INPUT-OUTPUT CONTROL </td> </tr> <tr> <td>CHKD. N. RHEAL</td> <td>DATE 3-22-65</td> </tr> <tr> <td>ENG. E. DE CASTRO</td> <td>DATE 5-6-65</td> </tr> <tr> <td>PROJ. ENG. E. DE CASTRO</td> <td>DATE 8-6-65</td> </tr> <tr> <td>PROD. E. DE CASTRO</td> <td>DATE 5-6-65</td> </tr> <tr> <td colspan="2">FIRST USED ON</td> <td colspan="3"></td> </tr> <tr> <td colspan="2">SCALE NONE</td> <td colspan="3"></td> </tr> <tr> <td colspan="2">SHEET 1 OF 1</td> <td colspan="3"></td> </tr> <tr> <td colspan="2">FINISH</td> <td colspan="3"></td> </tr> <tr> <td colspan="2">MATERIAL</td> <td colspan="3"></td> </tr> <tr> <td colspan="2">UNLESS OTHERWISE SPECIFIED</td> <td colspan="3"></td> </tr> <tr> <td colspan="2">UNLESS OTHERWISE SPECIFIED</td> <td colspan="3"></td> </tr> <tr> <td colspan="2">DIMENSION IN INCHES</td> <td colspan="3"></td> </tr> <tr> <td colspan="2">TOLERANCES</td> <td colspan="3"></td> </tr> <tr> <td colspan="2">DECIMALS FRACTIONS ANGLES</td> <td colspan="3"></td> </tr> <tr> <td colspan="2">±.005 ± 1/64 ± 0'30"</td> <td colspan="3"></td> </tr> <tr> <td colspan="2">FINAL SURFACE QUALITY</td> <td colspan="3"></td> </tr> <tr> <td colspan="2">REMOVE BURRS AND BREAK SHARP CORNERS</td> <td colspan="3"></td> </tr> <tr> <td colspan="2">REVISIONS</td> <td colspan="3"></td> </tr> <tr> <td>REV.</td> <td>NO.</td> <td>DATE</td> <td colspan="2"></td> </tr> <tr> <td>1</td> <td>1</td> <td>7-10-65</td> <td colspan="2"></td> </tr> <tr> <td>2</td> <td>1</td> <td>8-17-65</td> <td colspan="2"></td> </tr> <tr> <td>3</td> <td>1</td> <td>10-6-65</td> <td colspan="2"></td> </tr> <tr> <td>4</td> <td>1</td> <td>12-20-65</td> <td colspan="2"></td> </tr> <tr> <td>5</td> <td>1</td> <td>5-11-66</td> <td colspan="2"></td> </tr> <tr> <td>6</td> <td>1</td> <td>7-6-66</td> <td colspan="2"></td> </tr> <tr> <td>7</td> <td>1</td> <td>7-13-72</td> <td colspan="2"></td> </tr> <tr> <td>8</td> <td>1</td> <td></td> <td colspan="2"></td> </tr> </table> | | | | | DRN. D. WRIGHT | DATE 9-22-64 | digital EQUIPMENT CORPORATION <small>MAYNARD, MASSACHUSETTS</small> | INPUT-OUTPUT CONTROL | | CHKD. N. RHEAL | DATE 3-22-65 | ENG. E. DE CASTRO | DATE 5-6-65 | PROJ. ENG. E. DE CASTRO | DATE 8-6-65 | PROD. E. DE CASTRO | DATE 5-6-65 | FIRST USED ON | | | | | SCALE NONE | | | | | SHEET 1 OF 1 | | | | | FINISH | | | | | MATERIAL | | | | | UNLESS OTHERWISE SPECIFIED | | | | | UNLESS OTHERWISE SPECIFIED | | | | | DIMENSION IN INCHES | | | | | TOLERANCES | | | | | DECIMALS FRACTIONS ANGLES | | | | | ±.005 ± 1/64 ± 0'30" | | | | | FINAL SURFACE QUALITY | | | | | REMOVE BURRS AND BREAK SHARP CORNERS | | | | | REVISIONS | | | | | REV. | NO. | DATE | | | 1 | 1 | 7-10-65 | | | 2 | 1 | 8-17-65 | | | 3 | 1 | 10-6-65 | | | 4 | 1 | 12-20-65 | | | 5 | 1 | 5-11-66 | | | 6 | 1 | 7-6-66 | | | 7 | 1 | 7-13-72 | | | 8 | 1 | | | |
| DRN. D. WRIGHT | DATE 9-22-64 | digital EQUIPMENT CORPORATION <small>MAYNARD, MASSACHUSETTS</small> | INPUT-OUTPUT CONTROL | | | | | | | | | | | | | | | | | | | | | | | | | | | | | | | | | | | | | | | | | | | | | | | | | | | | | | | | | | | | | | | | | | | | | | | | | | | | | | | | | | | | | | | | | | | | | | | | | | | | | | | | | | | | | | | | | | | | | | | | | | | | | | | | | |
| CHKD. N. RHEAL | DATE 3-22-65 | | | | | | | | | | | | | | | | | | | | | | | | | | | | | | | | | | | | | | | | | | | | | | | | | | | | | | | | | | | | | | | | | | | | | | | | | | | | | | | | | | | | | | | | | | | | | | | | | | | | | | | | | | | | | | | | | | | | | | | | | | | | | | | | | | | |
| ENG. E. DE CASTRO | DATE 5-6-65 | | | | | | | | | | | | | | | | | | | | | | | | | | | | | | | | | | | | | | | | | | | | | | | | | | | | | | | | | | | | | | | | | | | | | | | | | | | | | | | | | | | | | | | | | | | | | | | | | | | | | | | | | | | | | | | | | | | | | | | | | | | | | | | | | | | |
| PROJ. ENG. E. DE CASTRO | DATE 8-6-65 | | | | | | | | | | | | | | | | | | | | | | | | | | | | | | | | | | | | | | | | | | | | | | | | | | | | | | | | | | | | | | | | | | | | | | | | | | | | | | | | | | | | | | | | | | | | | | | | | | | | | | | | | | | | | | | | | | | | | | | | | | | | | | | | | | | |
| PROD. E. DE CASTRO | DATE 5-6-65 | | | | | | | | | | | | | | | | | | | | | | | | | | | | | | | | | | | | | | | | | | | | | | | | | | | | | | | | | | | | | | | | | | | | | | | | | | | | | | | | | | | | | | | | | | | | | | | | | | | | | | | | | | | | | | | | | | | | | | | | | | | | | | | | | | | |
| FIRST USED ON | | | | | | | | | | | | | | | | | | | | | | | | | | | | | | | | | | | | | | | | | | | | | | | | | | | | | | | | | | | | | | | | | | | | | | | | | | | | | | | | | | | | | | | | | | | | | | | | | | | | | | | | | | | | | | | | | | | | | | | | | | | | | | | | | | | | |
| SCALE NONE | | | | | | | | | | | | | | | | | | | | | | | | | | | | | | | | | | | | | | | | | | | | | | | | | | | | | | | | | | | | | | | | | | | | | | | | | | | | | | | | | | | | | | | | | | | | | | | | | | | | | | | | | | | | | | | | | | | | | | | | | | | | | | | | | | | | |
| SHEET 1 OF 1 | | | | | | | | | | | | | | | | | | | | | | | | | | | | | | | | | | | | | | | | | | | | | | | | | | | | | | | | | | | | | | | | | | | | | | | | | | | | | | | | | | | | | | | | | | | | | | | | | | | | | | | | | | | | | | | | | | | | | | | | | | | | | | | | | | | | |
| FINISH | | | | | | | | | | | | | | | | | | | | | | | | | | | | | | | | | | | | | | | | | | | | | | | | | | | | | | | | | | | | | | | | | | | | | | | | | | | | | | | | | | | | | | | | | | | | | | | | | | | | | | | | | | | | | | | | | | | | | | | | | | | | | | | | | | | | |
| MATERIAL | | | | | | | | | | | | | | | | | | | | | | | | | | | | | | | | | | | | | | | | | | | | | | | | | | | | | | | | | | | | | | | | | | | | | | | | | | | | | | | | | | | | | | | | | | | | | | | | | | | | | | | | | | | | | | | | | | | | | | | | | | | | | | | | | | | | |
| UNLESS OTHERWISE SPECIFIED | | | | | | | | | | | | | | | | | | | | | | | | | | | | | | | | | | | | | | | | | | | | | | | | | | | | | | | | | | | | | | | | | | | | | | | | | | | | | | | | | | | | | | | | | | | | | | | | | | | | | | | | | | | | | | | | | | | | | | | | | | | | | | | | | | | | |
| UNLESS OTHERWISE SPECIFIED | | | | | | | | | | | | | | | | | | | | | | | | | | | | | | | | | | | | | | | | | | | | | | | | | | | | | | | | | | | | | | | | | | | | | | | | | | | | | | | | | | | | | | | | | | | | | | | | | | | | | | | | | | | | | | | | | | | | | | | | | | | | | | | | | | | | |
| DIMENSION IN INCHES | | | | | | | | | | | | | | | | | | | | | | | | | | | | | | | | | | | | | | | | | | | | | | | | | | | | | | | | | | | | | | | | | | | | | | | | | | | | | | | | | | | | | | | | | | | | | | | | | | | | | | | | | | | | | | | | | | | | | | | | | | | | | | | | | | | | |
| TOLERANCES | | | | | | | | | | | | | | | | | | | | | | | | | | | | | | | | | | | | | | | | | | | | | | | | | | | | | | | | | | | | | | | | | | | | | | | | | | | | | | | | | | | | | | | | | | | | | | | | | | | | | | | | | | | | | | | | | | | | | | | | | | | | | | | | | | | | |
| DECIMALS FRACTIONS ANGLES | | | | | | | | | | | | | | | | | | | | | | | | | | | | | | | | | | | | | | | | | | | | | | | | | | | | | | | | | | | | | | | | | | | | | | | | | | | | | | | | | | | | | | | | | | | | | | | | | | | | | | | | | | | | | | | | | | | | | | | | | | | | | | | | | | | | |
| ±.005 ± 1/64 ± 0'30" | | | | | | | | | | | | | | | | | | | | | | | | | | | | | | | | | | | | | | | | | | | | | | | | | | | | | | | | | | | | | | | | | | | | | | | | | | | | | | | | | | | | | | | | | | | | | | | | | | | | | | | | | | | | | | | | | | | | | | | | | | | | | | | | | | | | |
| FINAL SURFACE QUALITY | | | | | | | | | | | | | | | | | | | | | | | | | | | | | | | | | | | | | | | | | | | | | | | | | | | | | | | | | | | | | | | | | | | | | | | | | | | | | | | | | | | | | | | | | | | | | | | | | | | | | | | | | | | | | | | | | | | | | | | | | | | | | | | | | | | | |
| REMOVE BURRS AND BREAK SHARP CORNERS | | | | | | | | | | | | | | | | | | | | | | | | | | | | | | | | | | | | | | | | | | | | | | | | | | | | | | | | | | | | | | | | | | | | | | | | | | | | | | | | | | | | | | | | | | | | | | | | | | | | | | | | | | | | | | | | | | | | | | | | | | | | | | | | | | | | |
| REVISIONS | | | | | | | | | | | | | | | | | | | | | | | | | | | | | | | | | | | | | | | | | | | | | | | | | | | | | | | | | | | | | | | | | | | | | | | | | | | | | | | | | | | | | | | | | | | | | | | | | | | | | | | | | | | | | | | | | | | | | | | | | | | | | | | | | | | | |
| REV. | NO. | DATE | | | | | | | | | | | | | | | | | | | | | | | | | | | | | | | | | | | | | | | | | | | | | | | | | | | | | | | | | | | | | | | | | | | | | | | | | | | | | | | | | | | | | | | | | | | | | | | | | | | | | | | | | | | | | | | | | | | | | | | | | | | | | | | | | | |
| 1 | 1 | 7-10-65 | | | | | | | | | | | | | | | | | | | | | | | | | | | | | | | | | | | | | | | | | | | | | | | | | | | | | | | | | | | | | | | | | | | | | | | | | | | | | | | | | | | | | | | | | | | | | | | | | | | | | | | | | | | | | | | | | | | | | | | | | | | | | | | | | | |
| 2 | 1 | 8-17-65 | | | | | | | | | | | | | | | | | | | | | | | | | | | | | | | | | | | | | | | | | | | | | | | | | | | | | | | | | | | | | | | | | | | | | | | | | | | | | | | | | | | | | | | | | | | | | | | | | | | | | | | | | | | | | | | | | | | | | | | | | | | | | | | | | | |
| 3 | 1 | 10-6-65 | | | | | | | | | | | | | | | | | | | | | | | | | | | | | | | | | | | | | | | | | | | | | | | | | | | | | | | | | | | | | | | | | | | | | | | | | | | | | | | | | | | | | | | | | | | | | | | | | | | | | | | | | | | | | | | | | | | | | | | | | | | | | | | | | | |
| 4 | 1 | 12-20-65 | | | | | | | | | | | | | | | | | | | | | | | | | | | | | | | | | | | | | | | | | | | | | | | | | | | | | | | | | | | | | | | | | | | | | | | | | | | | | | | | | | | | | | | | | | | | | | | | | | | | | | | | | | | | | | | | | | | | | | | | | | | | | | | | | | |
| 5 | 1 | 5-11-66 | | | | | | | | | | | | | | | | | | | | | | | | | | | | | | | | | | | | | | | | | | | | | | | | | | | | | | | | | | | | | | | | | | | | | | | | | | | | | | | | | | | | | | | | | | | | | | | | | | | | | | | | | | | | | | | | | | | | | | | | | | | | | | | | | | |
| 6 | 1 | 7-6-66 | | | | | | | | | | | | | | | | | | | | | | | | | | | | | | | | | | | | | | | | | | | | | | | | | | | | | | | | | | | | | | | | | | | | | | | | | | | | | | | | | | | | | | | | | | | | | | | | | | | | | | | | | | | | | | | | | | | | | | | | | | | | | | | | | | |
| 7 | 1 | 7-13-72 | | | | | | | | | | | | | | | | | | | | | | | | | | | | | | | | | | | | | | | | | | | | | | | | | | | | | | | | | | | | | | | | | | | | | | | | | | | | | | | | | | | | | | | | | | | | | | | | | | | | | | | | | | | | | | | | | | | | | | | | | | | | | | | | | | |
| 8 | 1 | | | | | | | | | | | | | | | | | | | | | | | | | | | | | | | | | | | | | | | | | | | | | | | | | | | | | | | | | | | | | | | | | | | | | | | | | | | | | | | | | | | | | | | | | | | | | | | | | | | | | | | | | | | | | | | | | | | | | | | | | | | | | | | | | | | |

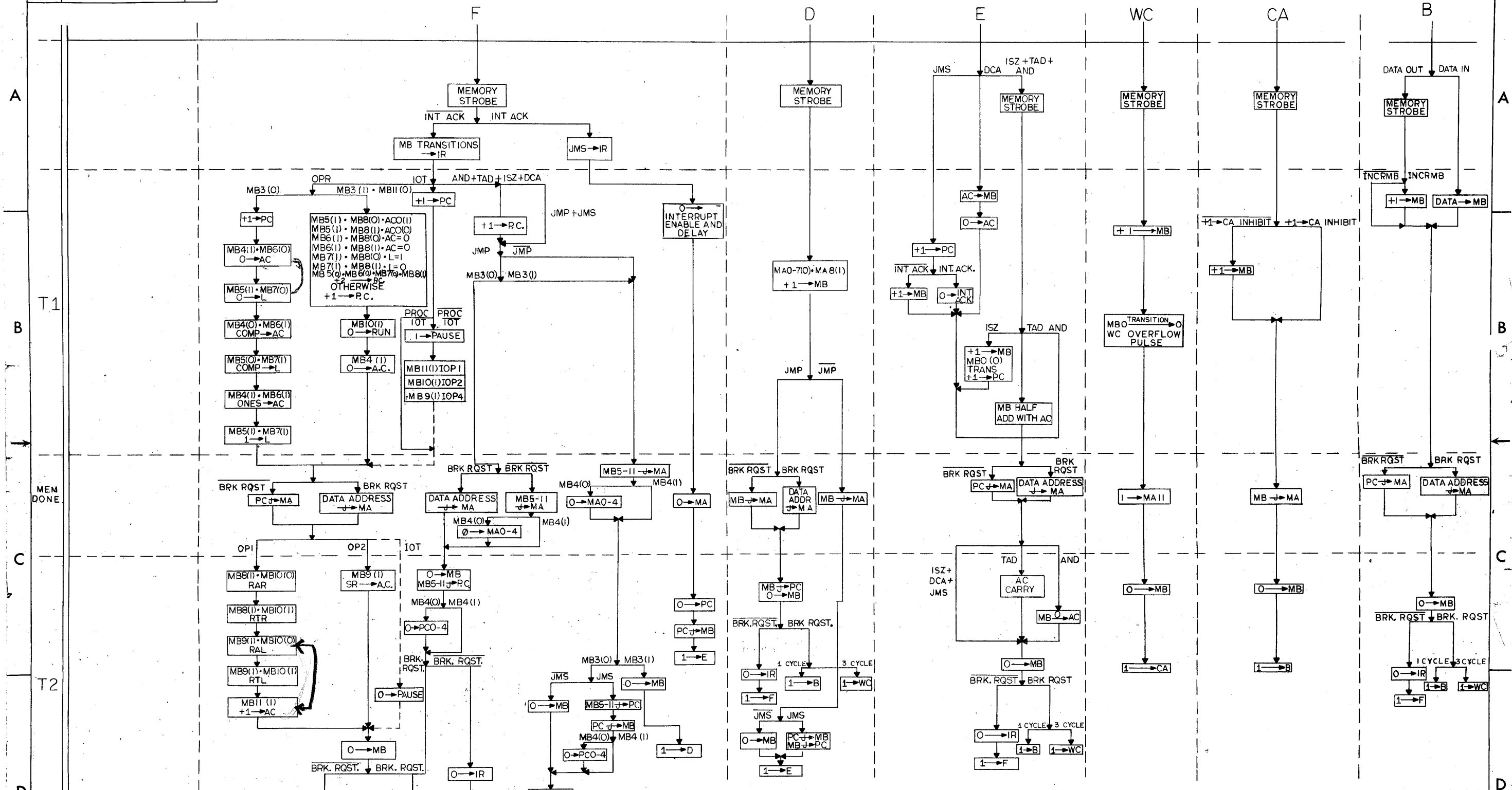

MEM DONE

T1

T2

BKE-2

| | | | | | | | |
|--------------|-----|---------|-------------|------------|--------------------------------------|--|-----------|
| REV. LTR. | NO. | DATE | REVISIONS | DRAWN | DATE | | TITLE |
| C | 19 | 8-24-64 | D. WRIGHT | 8-24-64 | FLOW DIAGRAM AUTOMATIC OPERATIONS | | |
| REV. LTR. | NO. | DATE | REVISIONS | CHECKED | DATE | | FOR |
| B | 19 | 3-22-65 | N. RHEAULT | 3-22-65 | | | |
| REV. LTR. | NO. | DATE | REVISIONS | ENG. | DATE | | ASSY NO. |
| A | 19 | 5-6-65 | E. DeCASTRO | 5-6-65 | | | |
| REV. LTR. | NO. | DATE | REVISIONS | PROJ. ENG. | DATE | | CODE |
| C | 19 | 5-6-65 | E. DeCASTRO | 5-6-65 | D-8P-0-7 | | |
| REV. LTR. | NO. | DATE | REVISIONS | PROD. | DATE | | REV. LTR. |
| C | 19 | 5-6-65 | E. DeCASTRO | 5-6-65 | C | | |
| SHEET 7 OF 2 | | | | | | | DIST. |
| | | | | | | | |

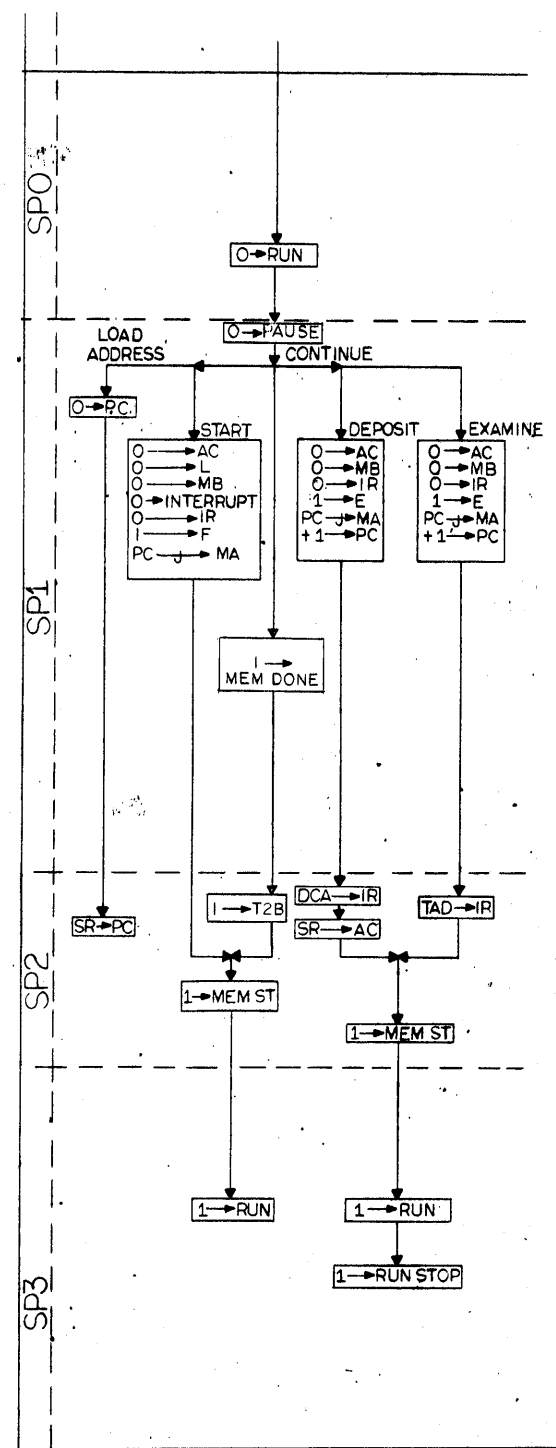

| | | | | | | |
|----------------------|--|---------|--|--|--------------|--|
| REV. LTR. | | DATE | | digital EQUIPMENT CORPORATION MAYNARD, MASSACHUSETTS | TITLE | |
| A | | 8-24-64 | | | FLOW DIAGRAM | |
| B | | 5-22-65 | | MANUAL OPERATIONS | | |
| C | | 5-6-65 | | FOR | | |
| REPLACED - NO CHANGE | | 5-6-65 | | ASSY NO. | | |
| E. DeCASTRO | | 5-6-65 | | CODE | | |
| E. DeCASTRO | | 5-6-65 | | DRWG. NO. | | |
| E. DeCASTRO | | 5-6-65 | | FD D-8P-0-7 | | |
| E. DeCASTRO | | 5-6-65 | | REV LTR | | |
| E. DeCASTRO | | 5-6-65 | | C | | |
| E. DeCASTRO | | 5-6-65 | | SCALE | | |
| E. DeCASTRO | | 5-6-65 | | SHEET 2 OF 2 | | |
| E. DeCASTRO | | 5-6-65 | | DIST. | | |

| | |
|-----------|---------|
| DRWG NO | REV LTR |
| B-8P-0-17 | AP |

| REVISIONS | | | |
|-------------------|----------|----------|-----|
| REV LTR | ECO NO | DATE | ENG |
| AK 243 | | 2-20-68 | RAM |
| REDRAWN & REVISED | | | |
| AL | 00001 | 7-3-68 | RAM |
| AM | 8P-00002 | 1-17-70 | RAM |
| AN | 8P-00004 | 11-12-70 | RAM |
| AP | 8P-00005 | 2-16-71 | RAM |

| | | | | | |
|-------------------------|-----------------|--|---------------------------------------|------------|---------------|
| DRAWN D. WRIGHT | DATE 12-1-64 |  digital EQUIPMENT CORPORATION MAYNARD, MASSACHUSETTS | TITLE WIRING LIST PDP8-0 (PROC) | | |
| CHECKED N. RHEULT | DATE 4-9-65 | | FOR TAPE # PDP8-0 FILE # 1 | | |
| ENG E. DECASTRO | DATE 5-6-65 | | SIZE K | CODE WL | REV LTR AP |
| PROJ ENG E. DECASTRO | DATE 5-6-65 | | DWG. NO. 8P-0-17 | | |
| PROD E. DECASTRO | DATE 5-6-65 | | ASSY NO | SCALE | SHEET OF |
| | | DIST. | | | |

| | | |
|---------------------------------|--|-------------------------|
| JACK <input type="checkbox"/> | PLUG <input checked="" type="checkbox"/> | LOCATION, LENGTH, ROUTE |
| FEMALE <input type="checkbox"/> | MALE <input checked="" type="checkbox"/> | PA 02 |

| COLOR | LOCATION | PIN | NAME | REMARKS |
|-----------|----------|-----|-------------|---------|
| W/BLK (X) | PA 02 | A | AC 0 (1) → | |
| W/BRN (Z) | ↑ | B | ↑ 1 (1) ↑ | |
| W/RED (R) | ↓ | C | 2 (1) | |
| W/ORN (O) | ↓ | D | 3 (1) | |
| W/YEL (Y) | ↓ | E | 4 (1) | |
| W/GRN (N) | ↓ | F | 5 (1) | |
| W/BLU (B) | ↓ | H | 6 (1) | |
| W/VIQ (V) | ↓ | J | 7 (1) | |
| W/GRY (G) | ↓ | K | 8 (1) | |
| WHT (W) | ↓ | L | 9 (1) | |
| W/BLK (X) | ↓ | M | ↓ 10 (1) ↓ | |
| W/BRN (Z) | PA 02 | N | AC 11 (1) → | |
| W/RED (R) | | P | | |
| W/ORN (O) | | R | | |
| W/YEL (Y) | | S | | |
| W/GRN (N) | | T | | |
| W/BLU (B) | | U | | |
| W/VIO (V) | | V | | |
| W/GRY (G) | | W | | |
| WHT (W) | | X | | |
| | | Y | | |
| | | Z | | |

| | | |
|---|---|--|
| DRAWN P.J. Priest 3-9-65 CHECKED <i>[Signature]</i> 3/9/65 ENG <i>[Signature]</i> | digital EQUIPMENT CORPORATION MAYNARD, MASSACHUSETTS | INDICATOR CONNECTOR TITLE INDICATOR CONNECTOR FOR AC BITS |
| APPV <i>[Signature]</i> | ECO. NO. REV. LTR. | DWG NO A-8P-0-26 SHEET OF |
| | | REV. LTR. A CODE CL |

A-DWGS No. 145
 CL-A-8-0-26

| | | |
|---------------------------------|--|-------------------------|
| JACK <input type="checkbox"/> | PLUG <input checked="" type="checkbox"/> | LOCATION, LENGTH, ROUTE |
| FEMALE <input type="checkbox"/> | MALE <input checked="" type="checkbox"/> | PA 04 |

| COLOR | LOCATION | PIN | NAME | REMARKS |
|-----------|----------|-----|-------------|---------|
| W/BLK (X) | PA 04 | A | PC 0 (1) → | |
| W/BRN (Z) | ↑ | B | ↑ 1 (1) ↑ | |
| W/RED (R) | ↑ | C | ↑ 2 (1) ↑ | |
| W/QRN (O) | ↑ | D | ↑ 3 (1) ↑ | |
| W/YEL (Y) | ↑ | E | ↑ 4 (1) ↑ | |
| W/GRN (N) | ↑ | F | ↑ 5 (1) ↑ | |
| W/BLU (B) | ↑ | H | ↑ 6 (1) ↑ | |
| W/VIO (V) | ↑ | J | ↑ 7 (1) ↑ | |
| W/GRY (G) | ↑ | K | ↑ 8 (1) ↑ | |
| WHT (W) | ↑ | L | ↑ 9 (1) ↑ | |
| W/BLK (X) | ↑ | M | ↓ 10 (1) ↓ | |
| W/BRN (Z) | ↑ | N | PC 11 (1) → | |
| W/RED (R) | ↑ | P | SR 0 | |
| W/QRN (O) | ↑ | R | ↑ 1 | |
| W/YEL (Y) | ↑ | S | ↑ 2 | |
| W/GRN (N) | ↑ | T | ↑ 3 | |
| W/BLU (B) | ↓ | U | ↓ 4 | |
| W/VIO (V) | PA 04 | V | SR 5 | |
| W/GRY (G) | | W | | |
| WHT (W) | | X | | |
| | | Y | | |
| | | Z | | |

| | | |
|--|---|---|
| DRAWN P.J. Priest 3-9-65 CHECKED <i>[Signature]</i> ENG | digital EQUIPMENT CORPORATION MAYNARD, MASSACHUSETTS | INDICATOR CONNECTOR TITLE INDICATOR CONNECTOR FOR PC & SR BITS |
| ECO. NO. REV. LTR. | DWG NO A-8P-0-28 | REV. LTR. A |
| SHEET OF | CODE CL | |

| | | |
|---------------------------------|--|-------------------------|
| JACK <input type="checkbox"/> | PLUG <input checked="" type="checkbox"/> | LOCATION, LENGTH, ROUTE |
| FEMALE <input type="checkbox"/> | MALE <input checked="" type="checkbox"/> | PB 04 |

| COLOR | LOCATION | PIN | NAME | REMARKS |
|-----------|----------|-----|------------|---------|
| W/BLK (X) | PB 04 | A | MQ 0 (1) → | |
| W/BRN (Z) | ↑ | B | ↑ 1 (1) | |
| W/RED (R) | ↑ | C | ↑ 2 (1) | |
| W/ORN (O) | ↑ | D | ↑ 3 (1) | |
| W/YEL (Y) | ↑ | E | ↑ 4 (1) | |
| W/GRN (N) | ↑ | F | ↑ 5 (1) | |
| W/BLU (B) | ↑ | H | ↑ 6 (1) | |
| W/VIO (V) | ↑ | J | ↑ 7 (1) | |
| W/GRY (G) | ↑ | K | ↑ 8 (1) | |
| WHT (W) | ↑ | L | ↑ 9 (1) | |
| W/BLK (X) | ↑ | M | ↓ 10 (1) → | |
| W/BRN (Z) | ↑ | N | MQ 11 (1) | |
| W/RED (R) | ↑ | P | SR 6 | |
| W/ORN (O) | ↑ | R | ↑ 7 | |
| W/YEL (Y) | ↑ | S | ↑ 8 | |
| W/GRN (N) | ↑ | T | ↑ 9 | |
| W/BLU (B) | ↑ | U | ↓ 10 | |
| W/VIO (V) | PB 04 | V | SR 11 | |
| W/GRY (G) | | W | | |
| WHT (W) | | X | | |
| | | Y | | |
| | | Z | | |

| | | |
|--|--|---|
| DRAWN P.J. Priest 3-9-65 CHECKED <i>[Signature]</i> ENG <i>[Signature]</i> |  digital EQUIPMENT CORPORATION MAYNARD, MASSACHUSETTS | INDICATOR CONNECTOR TITLE INDICATOR CONNECTOR FOR MQ & SR BITS |
| DWG NO A-8P-0-31 | REV. LTR. A | SHEET OF |
| ECO. NO. REV. LTR. | CODE CL | |

A-Disc Number
 01-A-8-0-31

| COLOR | NAME | PIN | LOCATION | LOCATION | REMARKS |
|-------|------------|-----|----------|----------|---------|
| | | A | | | BLANK |
| | | B | | | BLANK |
| W/BLK | GND | C | PE 03 | | |
| W/BRN | DATA ADD 0 | D | ↑ | | |
| W/RED | GND | × | | | |
| W/ORN | DATA ADD 1 | E | | | |
| W/YEL | GND | F | | | |
| W/GRN | DATA ADD 2 | H | | | |
| W/BLU | GND | J | | | |
| W/VIO | DATA ADD 3 | K | | | |
| W/GRY | GND | L | | | |
| WHT | DATA ADD 4 | M | | | |
| W/BLK | GND | N | | | |
| W/BRN | DATA ADD 5 | P | | | |
| W/RED | GND | R | | | |
| W/ORN | DATA ADD 6 | S | | | |
| W/YEL | GND | × | | | |
| W/GRN | DATA ADD 7 | T | | | |
| W/BLU | GND | U | | | |
| W/VIO | DATA ADD 8 | V | ↓ | | |
| W/GRY | GND | × | PE 03 | | |

| COLOR | NAME | PIN | LOCATION | LOCATION | REMARKS |
|-------|--------------|-----|----------|----------|---------|
| | | A | | | BLANK |
| | | B | | | BLANK |
| W/BLK | GND | C | PF 03 | | |
| W/BRN | DATA ADD 9 | D | ↑ | | |
| W/RED | GND | × | | | |
| W/ORN | DATA ADD 10 | E | | | |
| W/YEL | GND | F | | | |
| W/GRN | DATA ADD 11 | H | | | |
| W/BLU | GND | J | | | |
| W/VIO | BRK. REQUEST | K | | | |
| W/GRY | GND | L | | | |
| WHT | DATA DIRCT. | M | | | |
| W/BLK | GND | N | | | |
| W/BRN | BREAK (B) | P | | | |
| W/RED | GND | R | | | |
| W/ORN | ADD ACCEPTED | S | | | |
| W/YEL | GND | × | | | |
| W/GRN | MB INCREMENT | T | | | |
| W/BLU | GND | U | | | |
| W/VIO | | V | ↓ | | |
| W/GRY | GND | × | PF 03 | | |

| | | | | | | | | | |
|-----------|-------------------------------|--------|--------------|---|-------------------------------|------|-----------|------|--|
| REV. LTR. | ECO. NO. | DATE | ENG. |  digital EQUIPMENT CORPORATION MAYNARD, MASSACHUSETTS | SIGNAL CABLE CONNECTOR | | | | |
| A | Dwg No. W-8036 CL-A-8-0-36 | 6-7-65 | P. J. Priest | | TITLE DATA ADDRESS | | | | |
| | | | | DRAWN P. J. Priest | FOR | | | | |
| | | | | | CHECKED <i>[Signature]</i> | CODE | DRWG. NO. | REV. | |
| | | | | ENG. | | CL | A-8P-0-36 | A | |
| | | | | PROD. | SHEET 1 OF 2 | | | | |
| | | | | | DIST. | | | | |

| | | | | | | | | | |
|-----------|-------------------------------|--------|--------------|--|-------------------------------|------|-----------|------|--|
| REV. LTR. | ECO. NO. | DATE | ENG. |  digital EQUIPMENT CORPORATION MAYNARD, MASSACHUSETTS | SIGNAL CABLE CONNECTOR | | | | |
| A | Dwg No. W-8036 CL-A-8-0-36 | 6-7-65 | P. J. Priest | | TITLE DATA ADDRESS | | | | |
| | | | | DRAWN P. J. Priest | FOR | | | | |
| | | | | | CHECKED <i>[Signature]</i> | CODE | DRWG. NO. | REV. | |
| | | | | ENG. | | CL | A-8P-0-36 | A | |
| | | | | PROD. | SHEET 2 OF 2 | | | | |
| | | | | | DIST. | | | | |

| COLOR | NAME | PIN | LOCATION | LOCATION | REMARKS |
|-------|---------|-----|----------|----------|---------|
| | | A | | | BLANK |
| | | B | | | BLANK |
| W/BLK | GND | C | PE 04 | | |
| W/BRN | MB 0 IN | D | ↑ | | |
| W/RED | GND | × | | | |
| W/ORN | MB 1 IN | E | | | |
| W/YEL | GND | F | | | |
| W/GRN | MB 2 IN | H | | | |
| W/BLU | GND | J | | | |
| W/VIO | MB 3 IN | K | | | |
| W/GRY | GND | L | | | |
| WHT | MB 4 IN | M | | | |
| W/BLK | GND | N | | | |
| W/BRN | MB 5 IN | P | | | |
| W/RED | GND | R | | | |
| W/ORN | MB 6 IN | S | | | |
| W/YEL | GND | × | | | |
| W/GRN | MB 7 IN | T | | | |
| W/BLU | GND | U | | | |
| W/VIO | MB 8 IN | V | ↓ | | |
| W/GRY | GND | × | PE 04 | | |

| COLOR | NAME | PIN | LOCATION | LOCATION | REMARKS |
|-------|--------------|-----|----------|----------|---------|
| | | A | | | BLANK |
| | | B | | | BLANK |
| W/BLK | GND | C | PF 04 | | |
| W/BRN | MB 9 IN | D | ↑ | | |
| W/RED | GND | × | | | |
| W/ORN | MB 10 IN | E | | | |
| W/YEL | GND | F | ↓ | | |
| W/GRN | MB 11 IN | H | PF 04 | | |
| W/BLU | GND | J | | | |
| W/VIO | CYCLE SELECT | K | PF 04 | | |
| W/GRY | GND | L | | | |
| WHT | +I → CA INH. | M | PF 04 | | |
| W/BLK | GND | N | | | |
| W/BRN | WC OVERFLOW | P | PF 04 | | |
| W/RED | GND | R | | | |
| W/ORN | | S | | | |
| W/YEL | GND | × | | | |
| W/GRN | | T | | | |
| W/BLU | GND | U | | | |
| W/VIO | | V | | | |
| W/GRY | GND | × | | | |

| | | | | | | | | |
|---------|--------------------------------------|---------|-------------|--|------------------------|---------|-----------|------|
| EV. TR. | ECO. NO. | DATE | ENG. | digital EQUIPMENT CORPORATION MAYNARD MASSACHUSETTS | SIGNAL CABLE CONNECTOR | | | |
| A | Dwg. No. 19-SEE SH# 2 CL-A-8-0-37 | 6-7-65 | P.J. Priest | | TITLE | MB'S IN | | |
| B | 19-SEE SH# 2 | 10-6-65 | | DRAWN | 3-9-65 | FOR | | |
| | | | | CHECKED | | CODE | DRWG. NO. | REV. |
| | | | | ENG. | | CL | 8P-0-37 | B |
| | | | | PROD. | | SHEET | 1 OF 2 | |
| | | | | | | DIST. | | |

| | | | | | | | | |
|-----------|--------------------------------------|--------|-------------|--|------------------------|---------|-----------|------|
| REV. LTR. | ECO. NO. | DATE | ENG. | digital EQUIPMENT CORPORATION MAYNARD MASSACHUSETTS | SIGNAL CABLE CONNECTOR | | | |
| A | Dwg. No. 19-SEE SH# 2 CL-A-8-0-37 | 6-7-65 | P.J. Priest | | TITLE | MB'S IN | | |
| | | | | DRAWN | 3-9-65 | FOR | | |
| | | | | CHECKED | | CODE | DRWG. NO. | REV. |
| | | | | ENG. | | CL | 8P-0-37 | B |
| | | | | PROD. | | SHEET | 2 OF 2 | |
| | | | | | | DIST. | | |

| COLOR | NAME | PIN | LOCATION | LOCATION | REMARKS |
|-------|------|-----|----------|----------|---------|
| | | A | | | BLANK |
| | | B | | | BLANK |
| W/BLK | GND | C | PE 02 | | |
| W/BRN | IM 0 | D | ↑ | | |
| W/RED | GND | × | | | |
| W/ORN | IM 1 | E | | | |
| W/YEL | GND | F | | | |
| W/GRN | IM 2 | H | | | |
| W/BLU | GND | J | | | |
| W/VIO | IM 3 | K | | | |
| W/GRY | GND | L | | | |
| WHT | IM 4 | M | | | |
| W/BLK | GND | N | | | |
| W/BRN | IM 5 | P | | | |
| W/RED | GND | R | | | |
| W/ORN | IM 6 | S | | | |
| W/YEL | GND | × | | | |
| W/GRN | IM 7 | T | | | |
| W/BLU | GND | U | | | |
| W/VIO | IM 8 | V | ↓ | | |
| W/GRY | GND | × | PE 02 | | |

| COLOR | NAME | PIN | LOCATION | LOCATION | REMARKS |
|-------|-----------|-----|----------|----------|---------|
| | | A | | | BLANK |
| | | B | | | BLANK |
| W/BLK | GND | C | PF 02 | | |
| W/BRN | IM 9 | D | ↑ | | |
| W/RED | GND | × | | | |
| W/ORN | IM 10 | E | | | |
| W/YEL | GND | F | | | |
| W/GRN | IM 11 | H | | | |
| W/BLU | GND | J | | | |
| W/VIO | SKIP | K | | | |
| W/GRY | GND | L | | | |
| WHT | INTERRUPT | M | | | |
| W/BLK | GND | N | | | |
| W/BRN | AC CLEAR | P | | | |
| W/RED | GND | R | | | |
| W/ORN | RUN (1) | S | | | |
| W/YEL | GND | × | | | |
| W/GRN | | T | | | |
| W/BLU | GND | U | | | |
| W/VIO | | V | ↓ | | |
| W/GRY | GND | × | PF 02 | | |

| | | | | | | | | |
|-----------|-----------------------------|---------|--------------|---|------------------------------|----------------|-----------|------|
| REV. LTR. | ECO. NO. | DATE | ENG. | digital EQUIPMENT CORPORATION MAYNARD, MASSACHUSETTS | SIGNAL CABLE CONNECTOR | | | |
| A | Dwg. No. WPS CL-A-8-0-34 | 4/10/65 | P. J. Priest | | TITLE INPUT MIXER | | | |
| | | | | | DRAWN 3-9-65 P. J. Priest | | | |
| | | | | | FOR | CODE DRWG. NO. | | REV. |
| | | | | | | CL | A-8P-0-34 | A |
| | | | | | SHEET 1 OF 2 | | | |
| | | | | | PROD. 5/6/65 | | | |
| | | | | | DIST. | | | |

| | | | | | | | | |
|-----------|-----------------------------|------|------|---|------------------------------|----------------|-----------|------|
| REV. LTR. | ECO. NO. | DATE | ENG. | digital EQUIPMENT CORPORATION MAYNARD, MASSACHUSETTS | SIGNAL CABLE CONNECTOR | | | |
| A | Dwg. No. WPS CL-A-8-0-34 | | | | TITLE INPUT MIXER | | | |
| | | | | | DRAWN 3-9-65 P. J. Priest | | | |
| | | | | | FOR | CODE DRWG. NO. | | REV. |
| | | | | | | | A-8P-0-34 | A |
| | | | | | SHEET 2 OF 2 | | | |
| | | | | | PROD. | | | |
| | | | | | DIST. | | | |

| JACK <input type="checkbox"/> | | PLUG <input checked="" type="checkbox"/> | | LOCATION LENGTH, ROUTE | |
|---------------------------------|-------|--|---------|------------------------|--|
| FEMALE <input type="checkbox"/> | | MALE <input checked="" type="checkbox"/> | | PA01 & MA36 | |
| COLOR | PIN | PIN | NAME | REMARKS | |
| W/BLK (X) | PA01A | MA36A | AC0(1) | | |
| W/BRN (Z) | PA01B | MA36B | AC1(1) | | |
| W/RED (R) | ↑ C | ↑ C | GND | | |
| W/ORN (O) | D | D | AC2(1) | | |
| W/YEL (Y) | | E | 3(1) | | |
| W/GRN (N) | F | F | 4(1) | | |
| W/BLU (B) | H | H | 5(1) | | |
| W/VIO (V) | J | J | 6(1) | | |
| W/GRY (G) | K | K | 7(1) | | |
| WHT (W) | L | L | 8(1) | | |
| W/BLK (X) | M | M | 9(1) | | |
| W/BRN (Z) | N | N | 10(1) | | |
| W/RED (R) | P | P | AC11(1) | | |
| W/ORN (O) | R | R | SA 0 | | |
| W/YEL (Y) | S | S | ↑ 1 | | |
| W/GRN (N) | T | T | ↓ 2 | | |
| W/BLU (B) | ↓ U | ↓ U | SA 3 | | |
| W/VIO (V) | PA01V | MA36V | GND | | |

| | | | | |
|----------|--|---|---------------------------------------|-----------|
| DRAWN | |  DIGITAL EQUIPMENT CORPORATION MAYNARD, MASSACHUSETTS | INTERCHASSIS CONNECTOR | |
| CHECKED | | | TITLE | |
| ENG | | | PROCESSOR & MEMORY CHASSIS CONNECTORS | |
| APPRV | | 6/3/65 REV #1 00001 REV B | DWG NO | REV. LTR. |
| ECO. NO. | | | A-8-0-30 | B |
| SHEET | | 1 | OF | 7 |
| | | | CODE | CL |

| JACK <input type="checkbox"/> | | PLUG <input checked="" type="checkbox"/> | | LOCATION LENGTH, ROUTE | |
|---------------------------------|-------|--|----------|------------------------|--|
| FEMALE <input type="checkbox"/> | | MALE <input checked="" type="checkbox"/> | | PB01 & MB36 | |
| COLOR | PIN | PIN | NAME | REMARKS | |
| W/BLK (X) | PB01A | MB36A | TTI 0(1) | | |
| W/BRN (Z) | ↑ B | ↑ B | TTI 1(1) | | |
| W/RED (R) | C | C | GND | | |
| W/ORN (O) | D | D | SA 4 | | |
| W/YEL (Y) | E | E | ↑ 5 | | |
| W/GRN (N) | F | F | 6 | | |
| W/BLU (B) | H | H | 7 | | |
| W/VIO (V) | J | J | 8 | | |
| W/GRY (G) | K | K | 9 | | |
| WHT (W) | L | L | ↓ 10 | | |
| W/BLK (X) | M | M | SA 11 | | |
| W/BRN (Z) | N | N | MA 0(0) | | |
| W/RED (R) | P | P | MA 0(1) | | |
| W/ORN (O) | R | R | MA 1(0) | | |
| W/YEL (Y) | S | S | MA 1(1) | | |
| W/GRN (N) | T | T | MA 2(0) | | |
| W/BLU (B) | ↓ U | ↓ U | MA 2(1) | | |
| W/VIO (V) | PB01V | MB36V | GND | | |

| | | | | |
|----------|--|--|--------------------------------------|-----------|
| DRAWN | |  DIGITAL EQUIPMENT CORPORATION MAYNARD, MASSACHUSETTS | INTERCHASSIS CONNECTOR | |
| CHECKED | | | TITLE | |
| ENG | | | PROCESSOR & MEMORY CHASSIS CONNECTOR | |
| APPRV | | 3/15/65 S Clippinger | DWG NO | REV. LTR. |
| ECO. NO. | | | A-8-0-30 | B |
| SHEET | | 2 | OF | 7 |
| | | | CODE | CL |

| | | |
|---------------------------------|--|-------------------------|
| JACK <input type="checkbox"/> | PLUG <input checked="" type="checkbox"/> | LOCATION, LENGTH, ROUTE |
| FEMALE <input type="checkbox"/> | MALE <input checked="" type="checkbox"/> | PCØ1 & MC36 |

| COLOR | PIN | PIN | NAME | REMARKS |
|-----------|-------|-------|---------|---------|
| W/BLK (X) | PCØ1A | MC36A | TTI2(1) | |
| W/BRN (Z) | B | B | TTI3(1) | |
| W/RED (R) | C | C | GND | |
| W/ORN (O) | D | D | MA 3(0) | |
| W/YEL (Y) | E | E | 3(1) | |
| W/GRN (N) | F | F | 4(0) | |
| W/BLU (B) | H | H | 4(1) | |
| W/VIO (V) | J | J | 5(0) | |
| W/GRY (G) | K | K | 5(1) | |
| WHT (W) | L | L | 6(0) | |
| W/BLK (X) | M | M | 6(1) | |
| W/BRN (Z) | N | N | 7(0) | |
| W/RED (R) | P | P | 7(1) | |
| W/ORN (O) | R | R | 8(0) | |
| W/YEL (Y) | S | S | 8(1) | |
| W/GRN (N) | T | T | 9(0) | |
| W/BLU (B) | U | U | MA 9(1) | |
| W/VIO (V) | PCØ1V | MC36V | GND | |

| | | | | |
|-----------|--------------|--|--------------------------------------|--|
| DRAWN | 3/15/65 |  DIGITAL EQUIPMENT CORPORATION MAYNARD, MASSACHUSETTS | INTERCHASSIS CONNECTOR | |
| CHECKED | S Clippinger | | TITLE | |
| ENG | | | PROCESSOR & MEMORY CHASSIS CONNECTOR | |
| APPR. | | DWG NO | REV. LTR. | |
| REV. LTR. | | A-8-0-30 | B | |
| SHEET | | 3 OF 7 | CODE CL | |

| | | |
|---------------------------------|--|-------------------------|
| JACK <input type="checkbox"/> | PLUG <input checked="" type="checkbox"/> | LOCATION, LENGTH, ROUTE |
| FEMALE <input type="checkbox"/> | MALE <input checked="" type="checkbox"/> | PDØ1 & MD36 |

| COLOR | PIN | PIN | NAME | REMARKS |
|-----------|-------|-------|----------|---------|
| W/BLK (X) | PDØ1A | MD36A | TTI 4(1) | |
| W/BRN (Z) | B | B | TTI 5(1) | |
| W/RED (R) | C | C | GND | |
| W/ORN (O) | D | D | MA 10(0) | |
| W/YEL (Y) | E | E | 10(1) | |
| W/GRN (N) | F | F | 11(0) | |
| W/BLU (B) | H | H | MA 11(1) | |
| W/VIO (V) | J | J | MB 0(0) | |
| W/GRY (G) | K | K | 0(1) | |
| WHT (W) | L | L | 1(0) | |
| W/BLK (X) | M | M | 1(1) | |
| W/BRN (Z) | N | N | 2(0) | |
| W/RED (R) | P | P | 2(1) | |
| W/ORN (O) | R | R | 3(0) | |
| W/YEL (Y) | S | S | 3(1) | |
| W/GRN (N) | T | T | 4(0) | |
| W/BLU (B) | U | U | MB 4(1) | |
| W/VIO (V) | PDØ1V | MD36V | GND | |

| | | | | |
|-----------|--------------|--|--------------------------------------|--|
| DRAWN | 3/15/65 |  DIGITAL EQUIPMENT CORPORATION MAYNARD, MASSACHUSETTS | INTERCHASSIS CONNECTOR | |
| CHECKED | S Clippinger | | TITLE | |
| ENG | | | PROCESSOR & MEMORY CHASSIS CONNECTOR | |
| APPR. | | DWG NO | REV. LTR. | |
| REV. LTR. | | A-8-0-30 | B | |
| SHEET | | 4 OF 7 | CODE CL | |

| JACK <input type="checkbox"/> | | PLUG <input checked="" type="checkbox"/> | | LOCATION, LENGTH, ROUTE | |
|---------------------------------|-------|--|----------|-------------------------|--|
| FEMALE <input type="checkbox"/> | | MALE <input checked="" type="checkbox"/> | | PEØ1 & ME36 | |
| COLOR | PIN | PIN | NAME | REMARKS | |
| W/BLK (X) | PEØ1A | ME36A | TTI 6(1) | | |
| W/BRN (Z) | ↑ B | ↑ B | TTI 7(1) | | |
| W/RED (R) | C | C | GND | | |
| W/ORN (O) | D | D | MB 5(0) | | |
| W/YEL (Y) | L | E | ↑ 5(1) | | |
| W/GRN (N) | F | F | 6(0) | | |
| W/BLU (B) | H | H | 6(1) | | |
| W/VIO (V) | J | J | 7(0) | | |
| W/GRY (G) | K | K | 7(1) | | |
| WHT (W) | L | L | 8(0) | | |
| W/BLK (X) | M | M | 8(1) | | |
| W/BRN (Z) | N | N | 9(0) | | |
| W/RED (R) | P | P | 9(1) | | |
| W/ORN (O) | R | R | 10(0) | | |
| W/YEL (Y) | S | R | 10(1) | | |
| W/GRN (N) | T | T | ↓ 11(0) | | |
| W/BLU (B) | ↓ U | ↓ U | MB 11(1) | | |
| W/VIO (V) | PEØ1V | ME36V | GND | | |

| | | | | |
|------------------------------------|--|---|--------------------------------------|-----------|
| DRAWN 3/15/65 S Clippinger | |  DIGITAL EQUIPMENT CORPORATION MAYNARD, MASSACHUSETTS | INTERCHASSIS CONNECTOR | |
| CHECKED <i>[Signature]</i> 3/15/65 | | | TITLE | |
| ENG | | | PROCESSOR & MEMORY CHASSIS CONNECTOR | |
| | | APPV | | |
| | | ECO. NO. | DWG NO | REV. LTR. |
| | | REV. LTR. | A-8-0-30 | B |
| | | SHEET | 5 OF 7 | CODE CL |

| JACK <input type="checkbox"/> | | PLUG <input checked="" type="checkbox"/> | | LOCATION, LENGTH, ROUTE | |
|---------------------------------|-------|--|-------------------|-------------------------|--|
| FEMALE <input type="checkbox"/> | | MALE <input checked="" type="checkbox"/> | | PFØ1 & MF36 | |
| COLGR | PIN | PIN | NAME | REMARKS | |
| W/BLK (X) | PFØ1A | MF36A | FETCH (F) | | |
| W/BRN (Z) | ↑ B | ↑ B | B SET | | |
| W/RED (R) | C | C | MEMORY STROBE ENB | | |
| W/ORN (O) | E | E | MEM START | | |
| W/YEL (Y) | F | F | T 1B | | |
| W/GRN (N) | H | H | T 2A | | |
| W/BLU (B) | J | J | IOP 1 | | |
| W/VIO (V) | K | K | IOP 2 | | |
| W/GRY (G) | L | L | IOP 4 | | |
| WHT (W) | M | M | PWR CLR | | |
| W/BLK (X) | N | N | E SET | | |
| W/BRN (Z) | P | P | TTI AC | | |
| W/RED (R) | R | R | SKIP | | |
| W/ORN (O) | S | S | INTERRUPT | | |
| W/YEL (Y) | T | T | MEM DONE | | |
| W/GRN (N) | ↓ U | ↓ U | IOT 032 | | |
| W/BLU (B) | PFØ1V | MF36V | GND | | |
| W/VIO (V) | | | | | |

| | | | | |
|------------------------------------|--|--|--------------------------------------|-----------|
| DRAWN 3/15/65 S Clippinger | |  DIGITAL EQUIPMENT CORPORATION MAYNARD, MASSACHUSETTS | INTERCHASSIS CONNECTOR | |
| CHECKED <i>[Signature]</i> 3/15/65 | | | TITLE | |
| ENG | | | PROCESSOR & MEMORY CHASSIS CONNECTOR | |
| | | APPV | | |
| | | ECO. NO. | DWG NO | REV. LTR. |
| | | REV. LTR. | A-8-0-30 | B |
| | | SHEET | 6 OF 7 | CODE CL |

