

**digital**

**T M 8 - E**

**Engineering Drawings**

**Digital Equipment Corporation**

The material herein is for information purposes only and is subject to change without notice. Digital Equipment Corporation assumes no responsibility for any errors which may appear herein.

These drawings and specifications herein are the property of Digital Equipment Corporation and shall not be reproduced or copied or used in whole or in part as the basis for the manufacture or sale of items without written permission.

Copyright © 1975, Digital Equipment Corporation



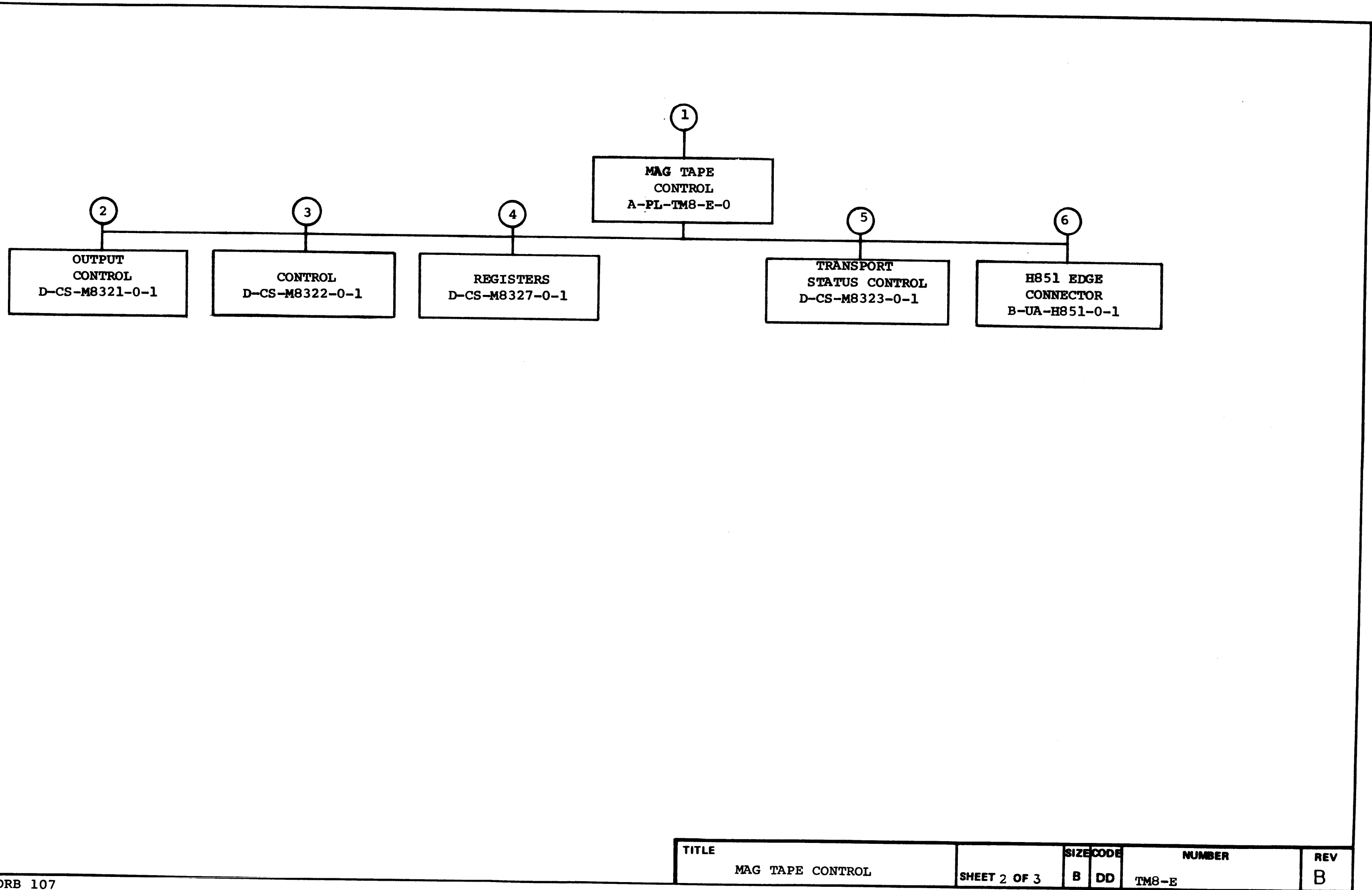

TITLE	MAG TAPE CONTROL	SHEET 2 OF 3	SIZE	CODE	NUMBER	REV
			B	DD	TM8-E	B

CUSTOMER PRINT SET				ELECTRICAL					CUSTOMER PRINT SET										
TMB-E			MFG. SET	FIND NO.	DRAWING NO.	REV	NO OF SHT	DESCRIPTION	OPTION NO./FILE DATE	TMB-E			MFG. SET	FIND NO.	DRAWING NO.	REV	NO OF SHT	DESCRIPTION	OPTION NO./FILE DATE
X				1	A-PL-TM8-E-0	*	1	MAG TAPE CONTROL						1	A-PL-TM8-E-0	*	1	MAG TAPE CONTROL	
X					D-TD-TM8-E-1	*	9	TIMING DIAGRAM (TM8E)											
X					D-MU-TM8-E-2	B	1	SIGNAL MAPPING (TM8E)											
X					D-IC-TM8-E-3	A	1	CABLE INTERCONNECTING (TM8-E)											
X					D-CS-M989-0-1	#	3	TERMINATOR CARD											
					D-UA-BC08L-0-0		1	I/O CABLE											
X					A-SP-TM8-E-4	A	21	ENG SPECIFICATIONS											
					A-SP-TM8-E-5	A	5	CHECKOUT PROCEDURE											
X					A-SL-TM8-E-7	A	1	SOFTWARE LIST											
X					A-AL-TM8-E-8		1	ACCESSORY LIST											
X					A-SP-TM8-E-9	A	8	ACCEPTANCE PROCEDURE											
X				2	D-CS-M8321-0-1	#	4	OUTPUT CONTROL											
X				3	D-CS-M8322-0-1	#	5	CONTROL											
X				4	D-CS-M8327-0-1	#	5	REGISTER											
X				5	D-CS-M8323-0-1	#	4	TRANSPORT STATUS CONTROL											
														6	B-UA-H851-0-0		1	H851 EDGE CONNECTOR	
															A-PL-H851-0-0		1	H851 EDGE CONNECTOR	
															B-MD-5509071		1	RECEP 36 PIN REWORK	
				6	B-UA-H851-0-0		1	H851 EDGE CONNECTOR											
					A-PL-H851-0-0		1	H851 EDGE CONNECTOR											
					D-IA-5008903-0-0		1	ETCH BOARD											

CUSTOMER PRINT SET CODES  
X = PRINT OF DOCUMENT INCLUDED IN PRINT SET  
C = INCLUDES ALL PRINTS INDICATED ON DOCUMENT  
S = CONFIDENTIAL AUTHORIZED SIGNATURE REQUIRED

TITLE  
MAG TAPE CONTROL  
SHEET 3 of 3  
SIZE CODE B DD  
NUMBER TM8-E  
REV B





This drawing and specifications, herein, are the property of Digital Equipment Corporation and shall not be reproduced or used in whole or in part as the basis for the manufacture or sale of items without written permission. © 1973  
 DTG:774L-ENRFP-CORP

SC-2 ERROR L FNI  
 SC-1 CONTROL BSY L FR2  
 CB-3 MTT L FMI  
 SC-1 TUR L FRI

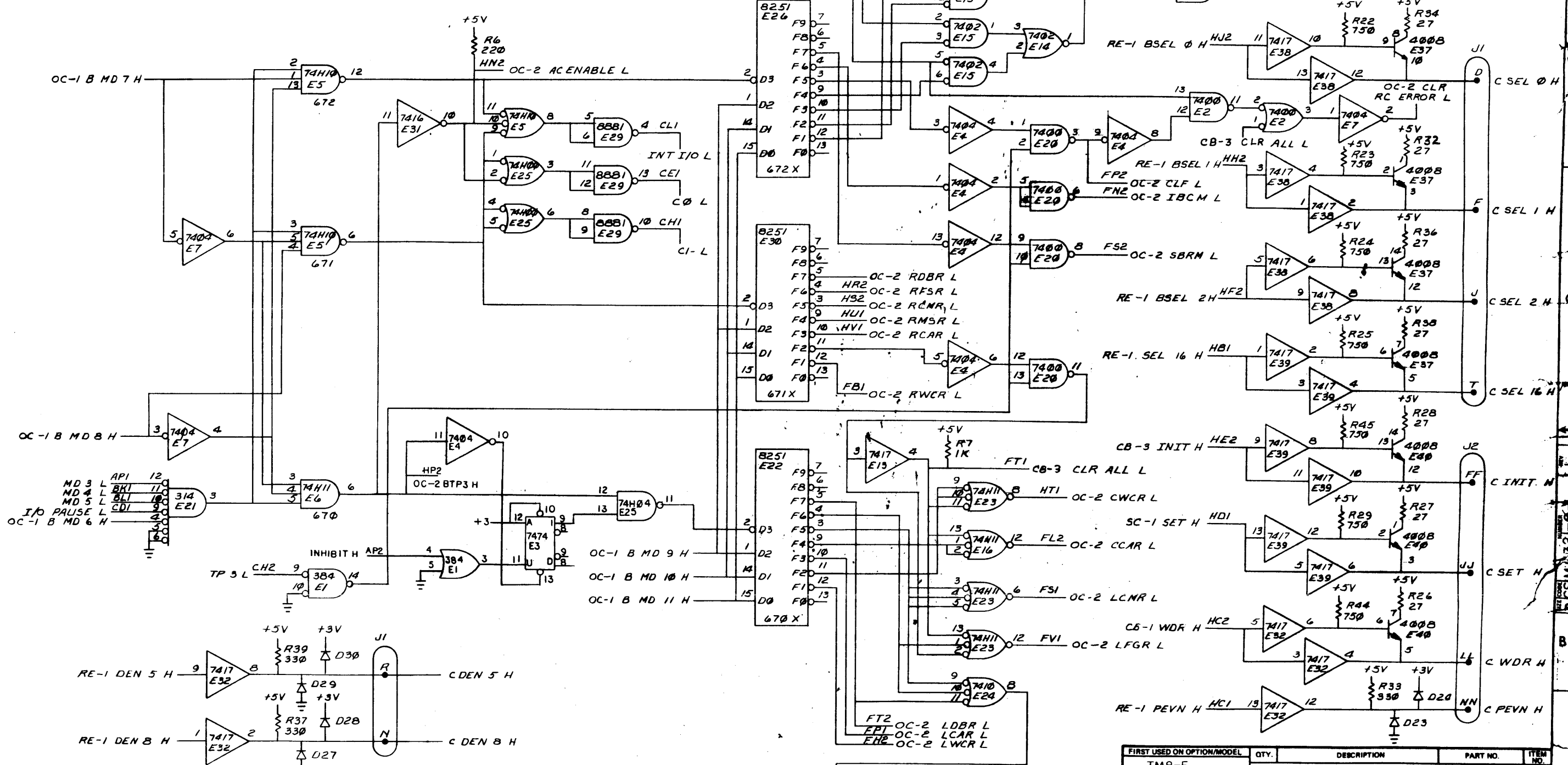

FIRST USED ON OPTION/MODEL	QTY.	DESCRIPTION	PART NO.	ITEM NO.
TM8-E				
UNLESS OTHERWISE SPECIFIED DIMENSION IN INCHES TOLERANCES				
DECIMALS	ANGLES	DATE 9-15-72		
.XXX - .008	±0° 30'	DATE 10/2/72		
.XX - .02		DATE 11/17-72		
.X - .1		DATE 12-11-72		
REMOVE BURRS AND BREAK SHARP CORNERS SURFACE QUALITY				
MATERIAL	NEXT HIGHER ASSEMBLY	TITLE		
FINISH	SCALE	OUTPUT CONTROL		
	SHEET 3 OF 3	TM8-E		
		(CC-2)		
		SIZE CODE	NUMBER	REV.
		D05	M8321-7-1	J

REV.	CHANGE NO.

DEC FORM NO. 107-B





This drawing and specifications, herein, are the property of Digital Equipment Corporation and shall not be reproduced or copied in whole or in part or the basis for the manufacture or sale of items without written permission.

1-0-2226M501

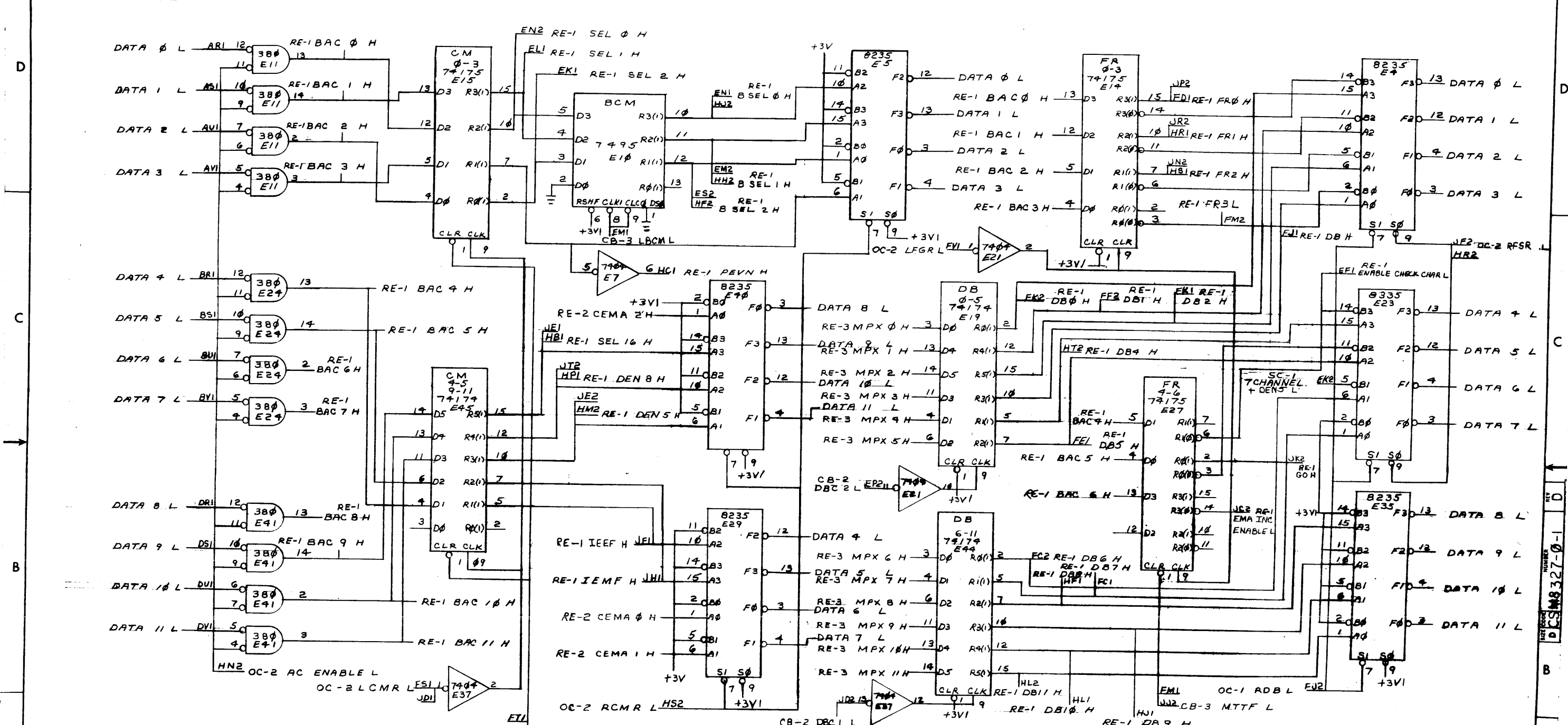

- FE2 > RC ERROR < JR1
- FN1 > ERROR L < EJ1
- HE2 > INIT H < JS2
- HVI > RMSR L < JS1
- FF1 > WR 1ST 7 H < JVI
- HNI > WR 2ND 7 H < JTI
- HDI > SET H < EE1
- HK2 > WR 9 H < JMI
- FUI > LCM+FB+DB L < JNI
- FRI > TUR L < EE2
- FS2 > SBRM L < EB1
- FP2 > CLF L < ED1
- FT2 > LDBR L < EA1
- HC2 > WDR H < EC1
- FR2 > CONTROL BSY < EC2
- HAI > MAC 2 H < JMI2
- \* FMI > MTF L < JU2
- FN2 > IBCM L < ED2

REVISIONS  
 REV  
 CHANGE NO.  
 CHK  
 DEC FORM NO  
 DDD 102-B

FIRST USED ON OPTION/MODEL	QTY.	DESCRIPTION	PART NO.	ITEM NO.
TM8-E				
UNLESS OTHERWISE SPECIFIED DIMENSION IN INCHES TOLERANCES				
DECIMALS .XXX = .006 .XX = .02 .X = .1	ANGLES ±0° 30'	PARTS LIST		
REMOVE BURRS AND BREAK SHARP CORNERS SURFACE QUALITY		TITLE		
MATERIAL		NEXT HIGHER ASSY.		
FINISH		SCALE NONE		
		SHEET 2 OF 4		
		DIST.		
		D		

digital EQUIPMENT CORPORATION  
 BATHURB MASSACHUSETTS  
 REGISTER  
 TM8-E (RE-1)  
 DCSM8327-0-1  
 REV D

This drawing and specifications, herein, are the property of Digital Equipment Corporation and shall not be reproduced or copied or used in whole or in part as the basis for the manufacture or sale of items without written permission.

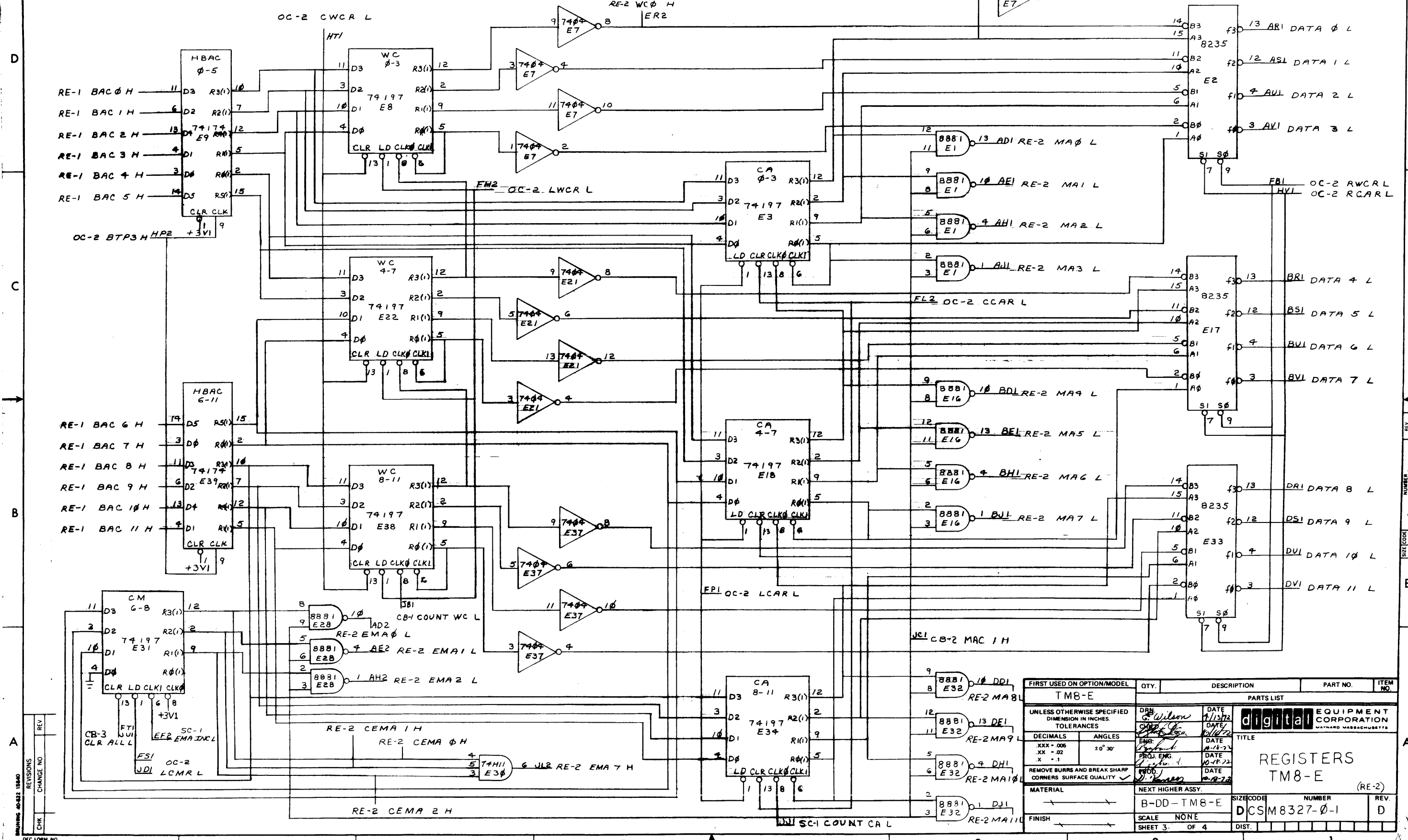

REV	CHG	NO	DATE

FIRST USED ON OPTION/MODEL	QTY.	DESCRIPTION	PART NO.	ITEM NO.									
TM8-E													
UNLESS OTHERWISE SPECIFIED DIMENSION IN INCHES. TOLERANCES													
DECIMALS .XXX - .006 .XX - .02 .X - .1	ANGLES ±0° 30'	PARTS LIST											
REMOVE BURRS AND BREAK SHARP CORNERS SURFACE QUALITY		<table border="1"> <tr> <td>DRN G. Wilson</td> <td>DATE 1/13/72</td> <td rowspan="4"> </td> </tr> <tr> <td>CHK J. ...</td> <td>DATE 10/11/72</td> </tr> <tr> <td>ENG: ...</td> <td>DATE 10-16-72</td> </tr> <tr> <td>PROJ. ENG. ...</td> <td>DATE 10-18-72</td> </tr> </table>			DRN G. Wilson	DATE 1/13/72		CHK J. ...	DATE 10/11/72	ENG: ...	DATE 10-16-72	PROJ. ENG. ...	DATE 10-18-72
DRN G. Wilson	DATE 1/13/72												
CHK J. ...	DATE 10/11/72												
ENG: ...	DATE 10-16-72												
PROJ. ENG. ...	DATE 10-18-72												
MATERIAL		<table border="1"> <tr> <td>NEXT HIGHER ASSY.</td> <td>SIZE CODE</td> <td>NUMBER</td> <td>REV.</td> </tr> <tr> <td>B-DD-TM8-E</td> <td>DCS M8327-0-1</td> <td> </td> <td>D</td> </tr> </table>			NEXT HIGHER ASSY.	SIZE CODE	NUMBER	REV.	B-DD-TM8-E	DCS M8327-0-1		D	
NEXT HIGHER ASSY.	SIZE CODE	NUMBER	REV.										
B-DD-TM8-E	DCS M8327-0-1		D										
FINISH		<table border="1"> <tr> <td>SCALE NONE</td> <td>SHEET 3 OF 4</td> <td colspan="2">DIST.</td> </tr> </table>			SCALE NONE	SHEET 3 OF 4	DIST.						
SCALE NONE	SHEET 3 OF 4	DIST.											

This drawing and specifications, herein, are the property of Digital Equipment Corporation and shall not be reproduced or copied or used in whole or in part as the basis for the manufacture or sale of items without written permission.

1-0-2280WCSJ 2  
 DCSM8327-0-1  
 3000 3215

NOTE: FORM CB

MPX	PIN 2	PIN 14
MPX	B	A
LOAD DB	L	L
WRITE	L	H
R7 cH	H	L
R9 cH	H	H

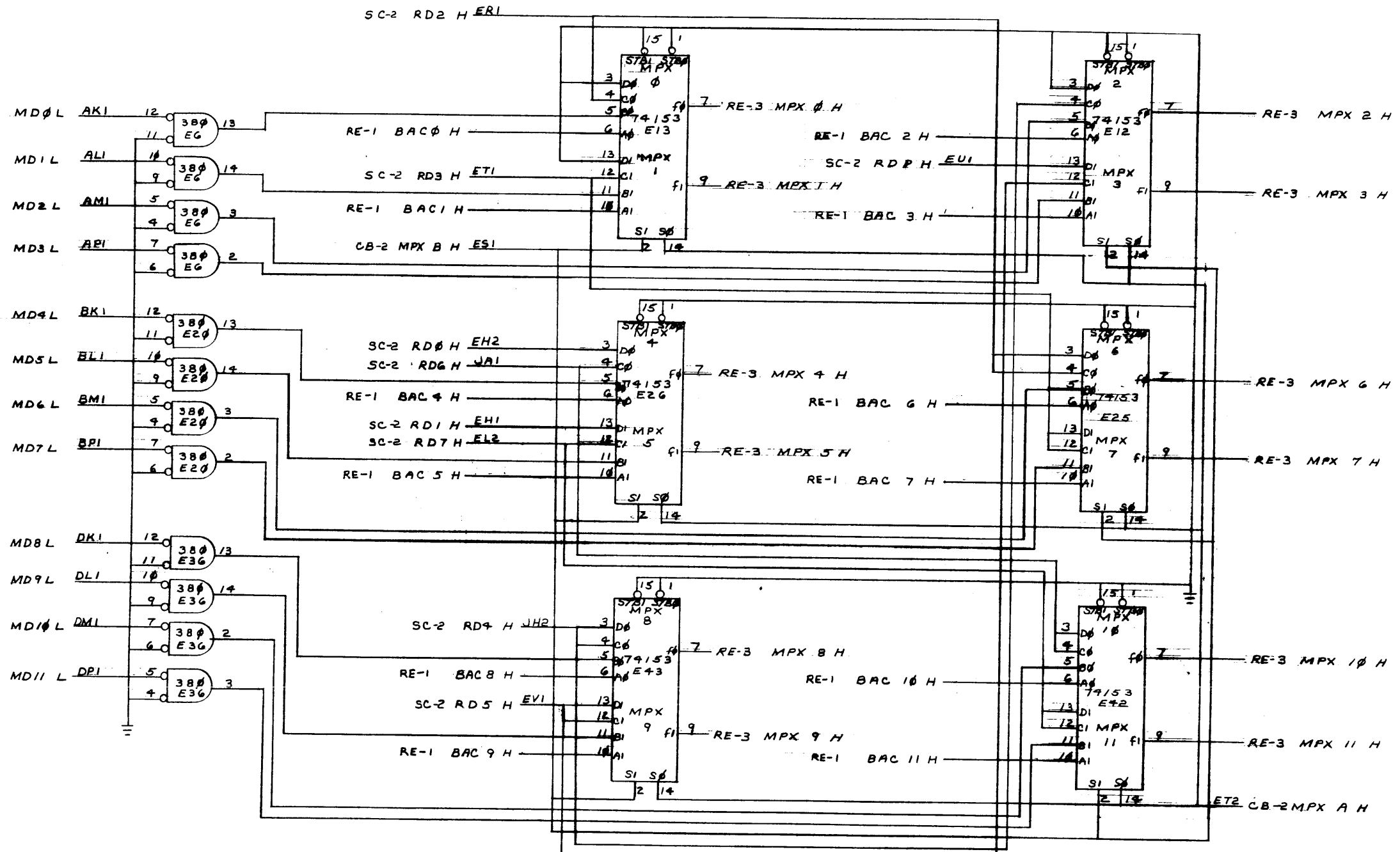

REV	CHANGE NO

REV. NO. 102-B

FIRST USED ON OPTION/MODEL	QTY.	DESCRIPTION	PART NO.	ITEM NO.
TM8-E				
PARTS LIST				
UNLESS OTHERWISE SPECIFIED DIMENSION IN INCHES. TOLERANCES		DRN C. Wilson	DATE 11/72	digital EQUIPMENT CORPORATION MAYNARD MASSACHUSETTS
DECIMALS	ANGLES	DATE 10/72	DATE 10/72	
.XXX - .005	±0° 30'	DATE 10/72	DATE 10/72	TITLE REGISTERS TM8-E (RE-3)
REMOVE BURRS AND BREAK SHARP CORNERS SURFACE QUALITY		DATE 10/72	DATE 10/72	SIZE CODE B-DD-TM8-E
MATERIAL		DATE 10/72	DATE 10/72	NUMBER DCSM8327-0-1
FINISH		DATE 10/72	DATE 10/72	REV. D
SCALE NONE		DATE 10/72	DATE 10/72	
SHEET 4 OF 4		DATE 10/72	DATE 10/72	





This drawing and specifications, herein, are the property of Digital Equipment Corporation and shall not be reproduced or copied or used in whole or in part as the basis for the manufacture or sale of items without written permission.

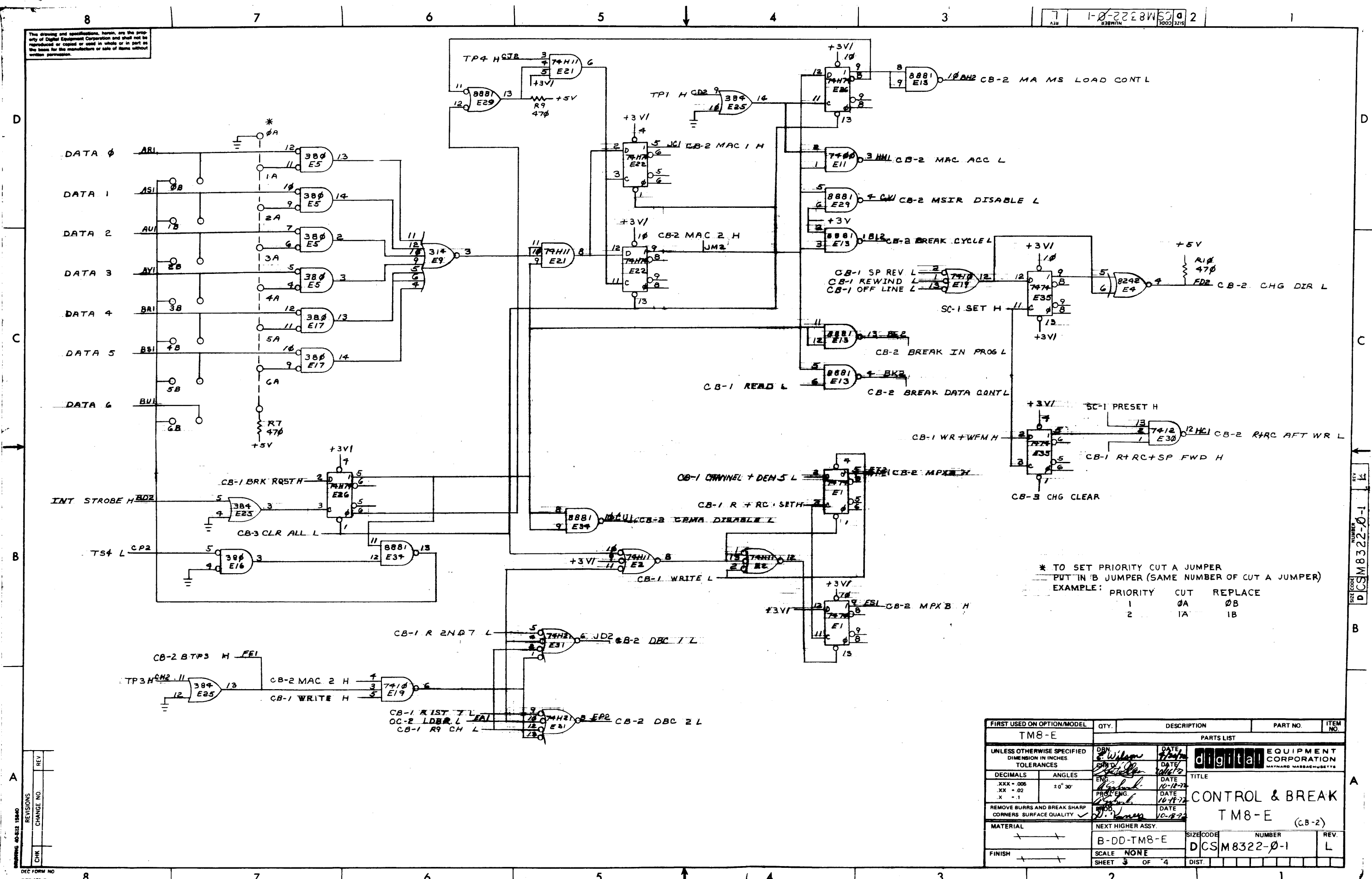

\* TO SET PRIORITY CUT A JUMPER  
 PUT IN 'B' JUMPER (SAME NUMBER OF CUT A JUMPER)  
 EXAMPLE: PRIORITY CUT REPLACE  
 1 0A 0B  
 2 1A 1B

FIRST USED ON OPTION/MODEL	QTY.	DESCRIPTION	PART NO.	ITEM NO.
TM8-E		PARTS LIST		
UNLESS OTHERWISE SPECIFIED DIMENSION IN INCHES TOLERANCES	DRN <i>Wilson</i>	DATE <i>10/18/72</i>	digital EQUIPMENT CORPORATION MAYNARD MASSACHUSETTS	
DECIMALS .XXX - .005	ENG <i>Wilson</i>	DATE <i>10-18-72</i>	TITLE CONTROL & BREAK TM8-E (C.B-2)	
ANGLES .XX - .02	PRG. ENG <i>Wilson</i>	DATE <i>10-18-72</i>	MATERIAL NEXT HIGHER ASSY.	
REMOVE BURRS AND BREAK SHARP CORNERS SURFACE QUALITY	PROD. <i>Wilson</i>	DATE <i>10-18-72</i>	FINISH	
			B-DD-TM8-E	SIZE CODE DCS M8322-0-1
			SCALE NONE	NUMBER L
			SHEET 3 OF 4	REV. L

REV	CHANGE NO.	REVISIONS

REV 14  
 NUMBER DCS M8322-0-1  
 SIZE CODE B









The drawing and specifications, herein, are the property of Digital Equipment Corporation and shall not be reproduced or copied in whole or in part or the name for the manufacture or sale of items without written permission. COMPANY 1973

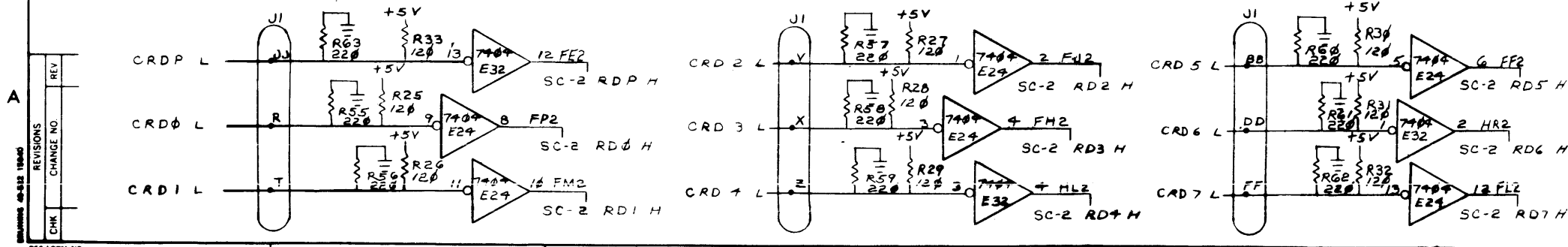
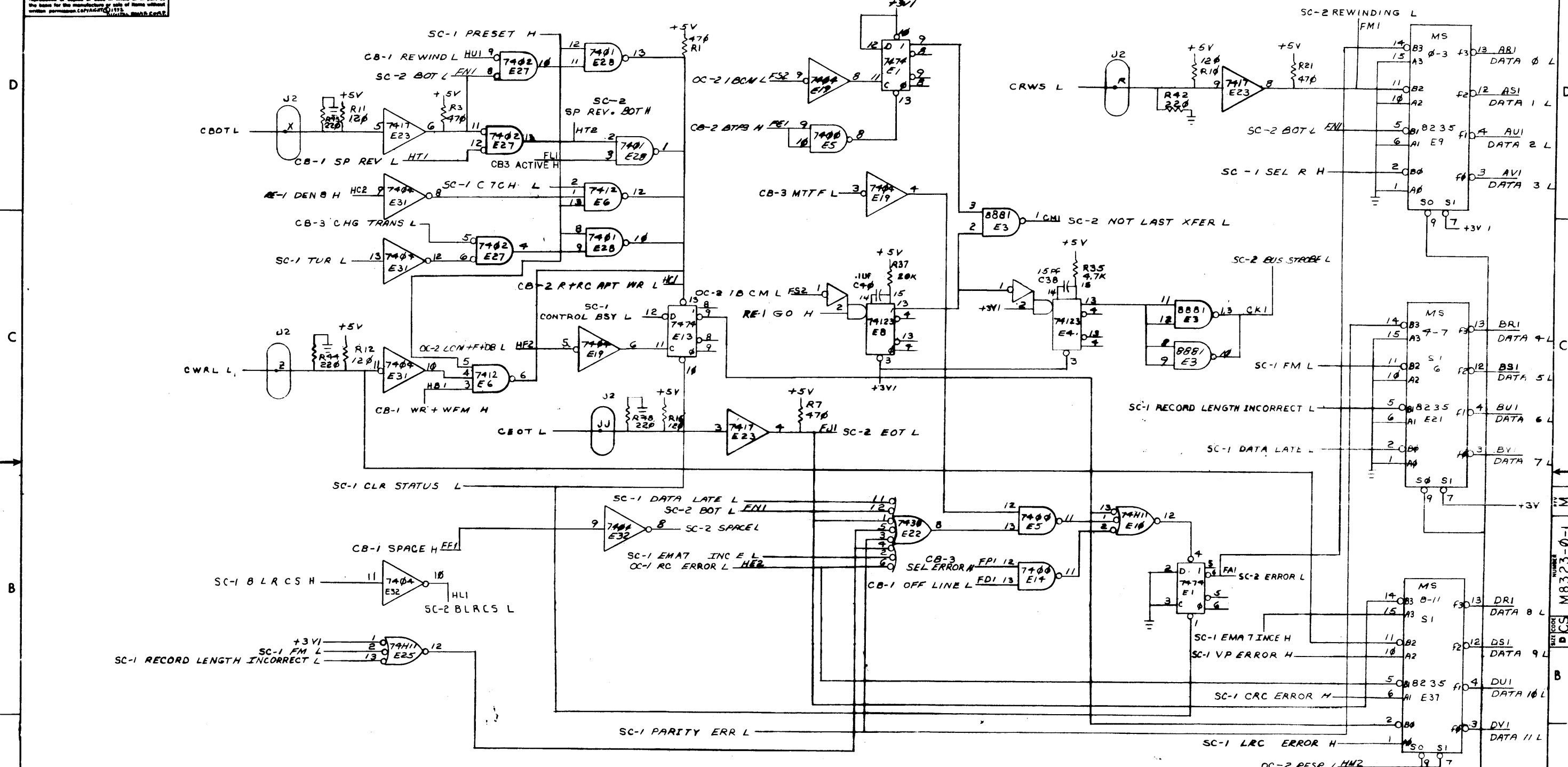

FIRST USED ON/MODEL	QTY	DESCRIPTION	PART NO	ITEM NO
TM8-E				
PARTS LIST				
UNLESS OTHERWISE SPECIFIED DIMENSION IN INCHES TOLERANCES				
DECIMALS	ANGLES	DATE 3/30/72		
XXX - 006	±0°30'	DATE 10/11/73		
XX - 02		DATE 10/15/73		
X - 1		DATE 10/17/73		
REMOVE BURRS AND BREAK SHARP CORNERS SURFACE QUALITY				
MATERIAL NEXT HIGHER ASSY.				
B-DD-TM8-E		SIZE CODE	NUMBER	REV
SCALE NONE		DCS	M8323-0-1	M
SHEET 3 OF 3		DIST		

REVISIONS  
REV. CHANGE NO.  
CHK

ITEM NO. M8323-0-1 M

A





This drawing and specifications, herein, are the property of Digital Equipment Corporation and shall not be reproduced or copied or used in whole or in part as the basis for the manufacture or sale of items without written permission. COPYRIGHT © DIGITAL EQUIPMENT CORPORATION

REV A36 NUMBER 1-0-686W SCS a 2

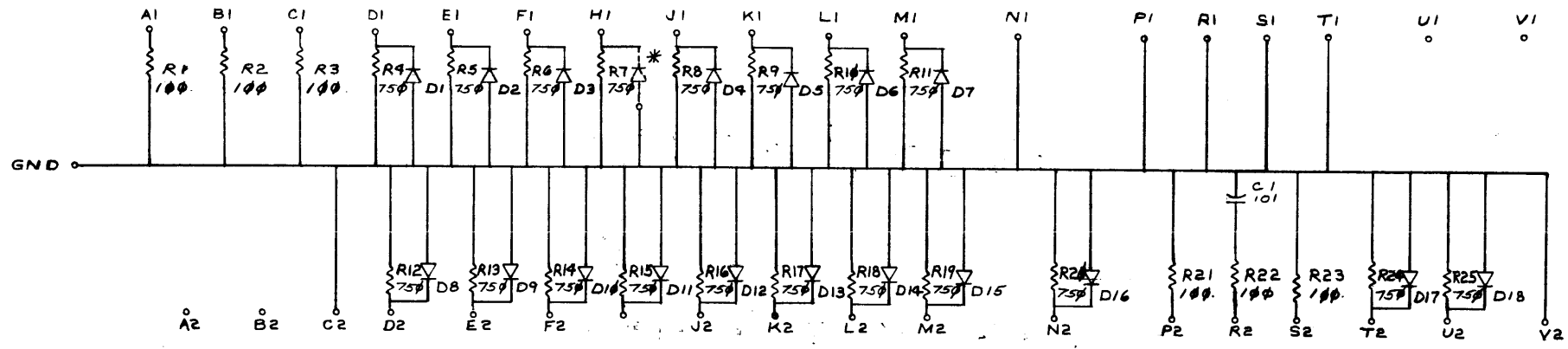

NOTE:  
\* ETCHED FOR FUTURE DIODE

REV	
CHANGE NO	
CHK	

DEC FORM NO LMD 102-B

FIRST USED ON OPTION/MODEL TM8-E	QTY.	DESCRIPTION	PART NO.	ITEM NO.
PARTS LIST				
UNLESS OTHERWISE SPECIFIED DIMENSION IN INCHES.	DRN. <i>G. Wilson</i>	DATE <i>5/19/72</i>	DIGITAL EQUIPMENT CORPORATION MAYNARD MASSACHUSETTS	
TOLERANCES	CHKD. <i>John J. Gagn</i>	DATE <i>10/16/72</i>	TITLE TERMINATOR CARD FOR TM8-E	
DECIMALS .XXX - .005	ENG. <i>John J. Gagn</i>	DATE <i>10/16/72</i>	REV. <i>10/16/72</i>	
.XX - .02	PROJ. ENGR. <i>John J. Gagn</i>	DATE <i>10/16/72</i>	DATE <i>10/16/72</i>	
.X - .1	PROD. ENGR. <i>J. Hennes</i>	DATE <i>10/16/72</i>	DATE <i>10/16/72</i>	
REMOVE BURRS AND BREAK SHARP CORNERS SURFACE QUALITY ✓				
MATERIAL	NEXT HIGHER ASSY.			
FINISH	B-DD-TM8E	SIZE CODE	NUMBER	REV.
	SCALE NONE	DCSM989-0-1		A
	SHEET 3 OF	DIST.		

REV A  
DCSM989-0-1

A

part 4

and specifications, herein, are the prop-  
erty of Digital Equipment Corporation and shall not be  
reproduced or used in whole or in part as  
the basis for the manufacture or sale of items without  
the express written permission of Digital Equipment Corporation.  
COPYRIGHT ©  
DIGITAL EQUIPMENT CORPORATION

AI	AZ	BI	BZ	CI	CZ	DI	DZ	EI	EZ	FI	FZ	HI	HI	JI	KI	KZ	LI	LI	MI	MI	NI	NI	PI	PI	RI	RI	SI	SI	TZ	UI	UI	VI	VZ																								
SC-2 RDS H	CB-1 COUNT WC L	CB-2 MAC 1 H	RE-1 EMA INC ENABLE L	OC-2 LCMR L	CB-2 DBC 1 L	RE-1 SEL 16 H	RE-1 DEN 5 H	RE-1 JEEF H	OC-2 RFSR L	RE-1 ZMF H	SC-1 COUNT CAL	CB-3 MTF L	RE-1 GO H	RE-2 EMA 7 H	CB-1 WR 9 H	CB-2 MAC 2 H	OC-2 LCM+FD L	RE-1 FRZ H	RE-1 FR 0 H	OC-1 RC ERROR L	RE-1 FR 1 H	OC-2 RMSR L	CB-3 INIT H	CB-1 WR 2ND 7 H	RE-1 DEN 5 H	CB-3 CLR ALL L	CB-1 WR 1ST 7 H	OC-2 LDBR L	OC-2 SBRM L	CB-1 WDR H	SC-1 CONTROL BSY L	OC-2 CLF L	OC-2 IBCM L	SC-1 SET H	SC-1 TUR L	RE-1 EMABE CHECK CHNL	SC-1 EMA INC L	SC-2 RDI H	SC-2 RDB H	SC-2 ERROR L	RE-1 SEL 2 H	SC-1 CHANNEL+DEN 5 L	RE-1 SEL 1 H	SC-2 RD 7 H	CB-3 LCM L	RE-1 BSEL 1 H	RE-1 BSEL 0 H	RE-1 SEL 0 H	CB-2 DBC 2 L	SC-2 RD 2 H	RE-2 WCR H	CB-2 MPK B H	RE-1 B SEL 2 H	SC-2 RDS H	CB-2 MPX H	SC-2 RDP H	SC-2 RDS H

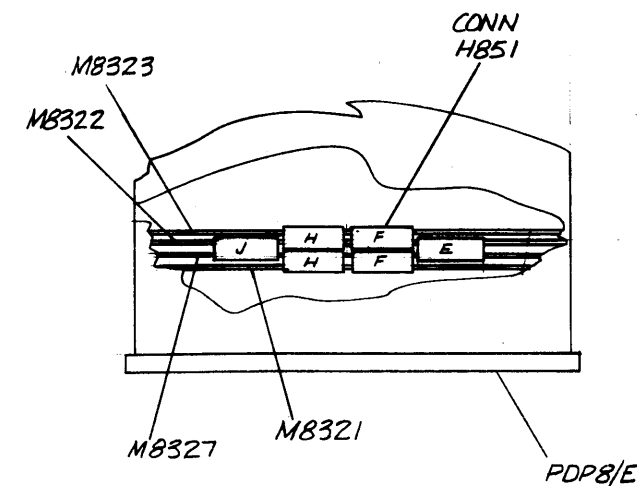

FIRST USED ON OPTION/MODEL <b>TM8-E</b>	QTY.	DESCRIPTION	PART NO.	ITEM NO.
PARTS LIST				
UNLESS OTHERWISE SPECIFIED DIMENSION IN INCHES. TOLERANCES	DATE 3/16/72	DATE 10/16/72	digital EQUIPMENT CORPORATION MAYFORD MASSACHUSETTS	
DECIMALS	ANGLES	DATE 10/16/72	TITLE SIGNAL MAPPING (TM8-E)	
XXX - .006 XX - .02 X - .1	± 0° 30'	DATE 11-8-72	REVISIONS	
REMOVE BURRS AND BREAK SHARP CORNERS SURFACE QUALITY	PROB.	DATE 10-18-72	A. CZAJKOWSKI 5-8-72 J. C. ... LORD ...	
MATERIAL #	NEXT HIGHER ASSY.	SCALE #	SIZE CODE DMU	NUMBER TM8-E-2
FINISH #	SHEET / OF /	DIST.	REV. B	

CHK	CHANGE NO	REV
...	...	...

This drawing and specifications, herein, are the property of Digital Equipment Corporation and shall not be reproduced or copied or used in whole or in part as the basis for the manufacture or sale of items without written permission. COPYRIGHT © DIGITAL EQUIPMENT CORPORATION

REV. 13M A  
 NUMBER 3387M  
 CODE 3216  
 2  
 1

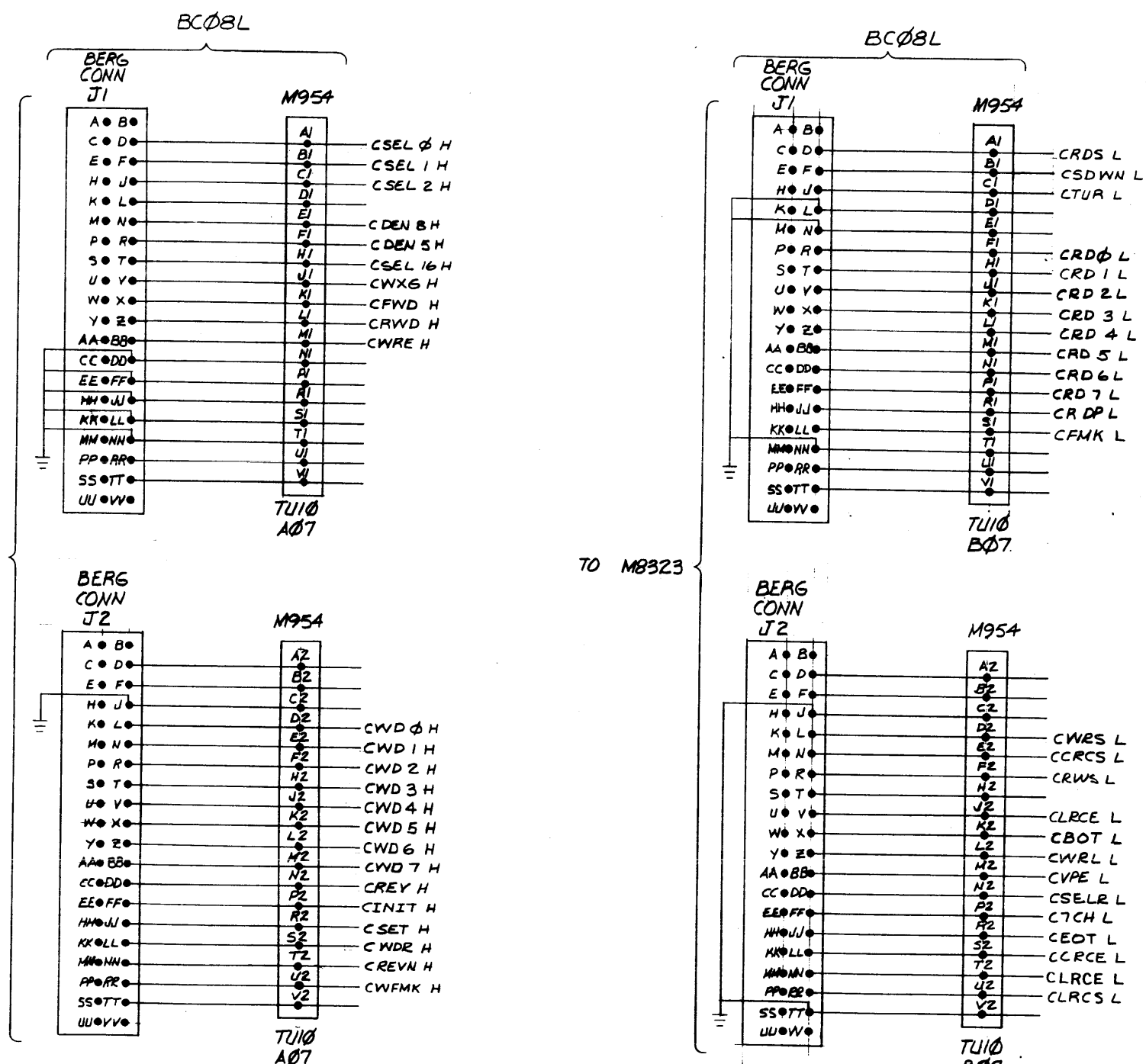

TO M8321

TO M8323

REVISIONS	REV
CHANGE NO.	REV
CHK	REV
TM8E-0001	A
4-26-73	
A. CZAJKOWSKI	
5-1-73	

FIRST USED ON OPTION/MODEL TM8-E	QTY.	DESCRIPTION	PART NO.	ITEM NO.
PARTS LIST				
UNLESS OTHERWISE SPECIFIED DIMENSION IN INCHES. TOLERANCES	DRAWN DATE	DATE	DIGITAL EQUIPMENT CORPORATION MAYNARD MASSACHUSETTS	
DECIMALS .XXX - .006	ENGR.	DATE	TITLE	
ANGLES ±0° 30'	DATE	DATE	CABLE INTERCONNECTING (TM8-E)	
REMOVE BURRS AND BREAK SHARP CORNERS SURFACE QUALITY	DATE	DATE	REV. A	
MATERIAL	NEXT HIGHER ASSY.	SCALE	SIZE CODE	NUMBER
FINISH	B-DD-TM8-E	SHEET / OF /	DIC	TM8-E-3
			DIST.	

This drawing and specifications, herein, are the property of Digital Equipment Corporation and shall not be reproduced or copied or used in whole or in part as the basis for the manufacture or sale of items without written permission. COPYRIGHT © 1972 DIGITAL EQUIPMENT CORPORATION

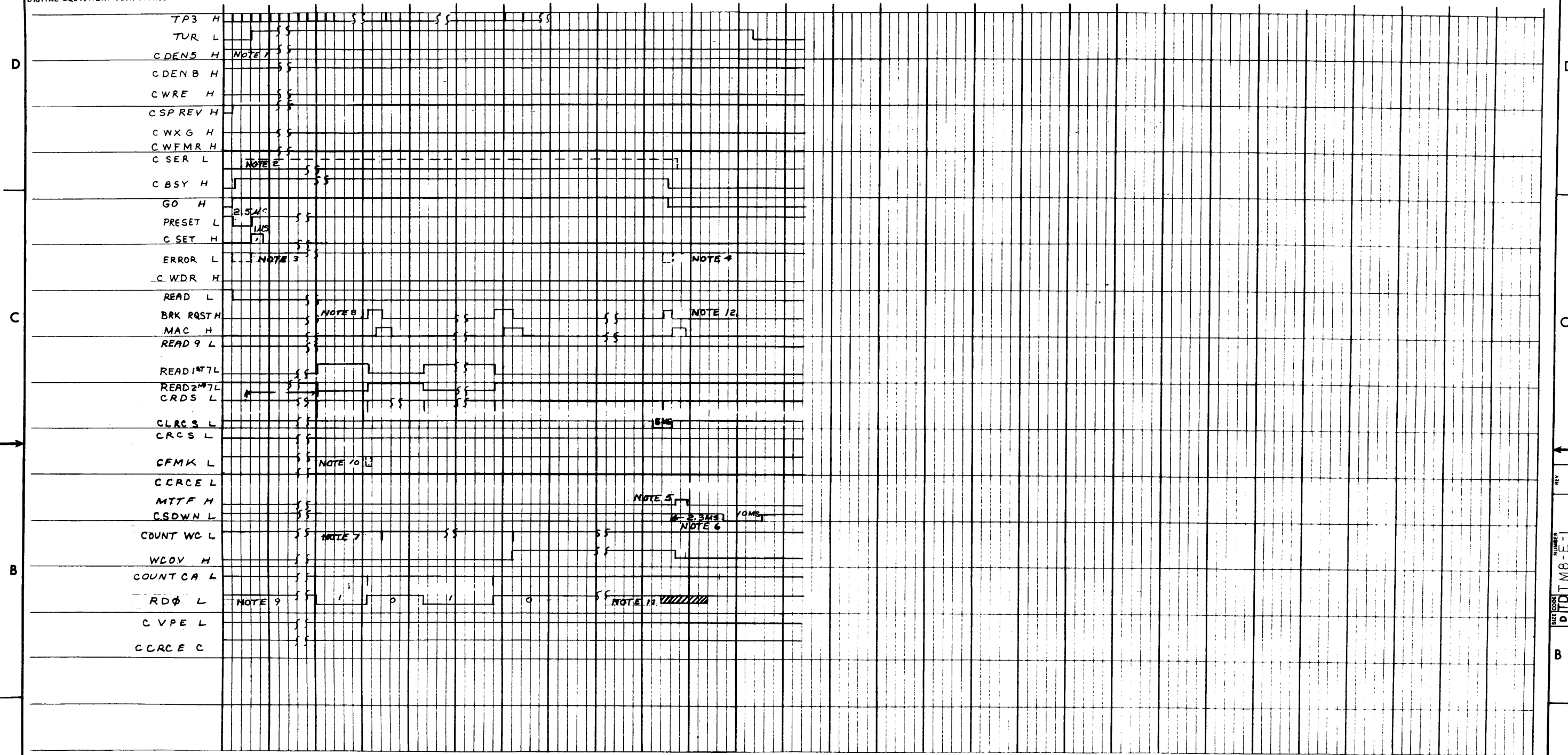

READ 7 TRACK  
FOR NOTES SEE SHEET 9 OF 9

REV	
CHANGE NO.	
CHK	

FIRST USED ON OPTION/MODEL TM8-E	QTY.	DESCRIPTION	PART NO.	ITEM NO.
PARTS LIST				
UNLESS OTHERWISE SPECIFIED DIMENSION IN INCHES. TOLERANCES	DRN Wilson DATE 9/19/72	DATE 9/19/72	digital EQUIPMENT CORPORATION MAYNARD MASSACHUSETTS	
DECIMALS .XXX - .005	ENG Wilson DATE 9/23/72	DATE 9/23/72	TITLE TIMING DIAGRAM TM8-E	
ANGLES ± 0° 30'	PROB ENG Wilson DATE 9/29/72	DATE 9/29/72	NUMBER D T D T M 8 - E - 1	
REMOVE BURRS AND BREAK SHARP CORNERS SURFACE QUALITY	NEXT HIGHER ASSY.	REV.		
MATERIAL	B-DD-TM8-E	SCALE NONE	SHEET 1	OF 9
FINISH		DIST.		



This drawing and specifications, herein, are the property of Digital Equipment Corporation and shall not be reproduced or copied or used in whole or in part as the basis for the manufacture or sale of items without written permission. COPYRIGHT © 1972 DIGITAL EQUIPMENT CORPORATION

DTD TM8-E-1 2

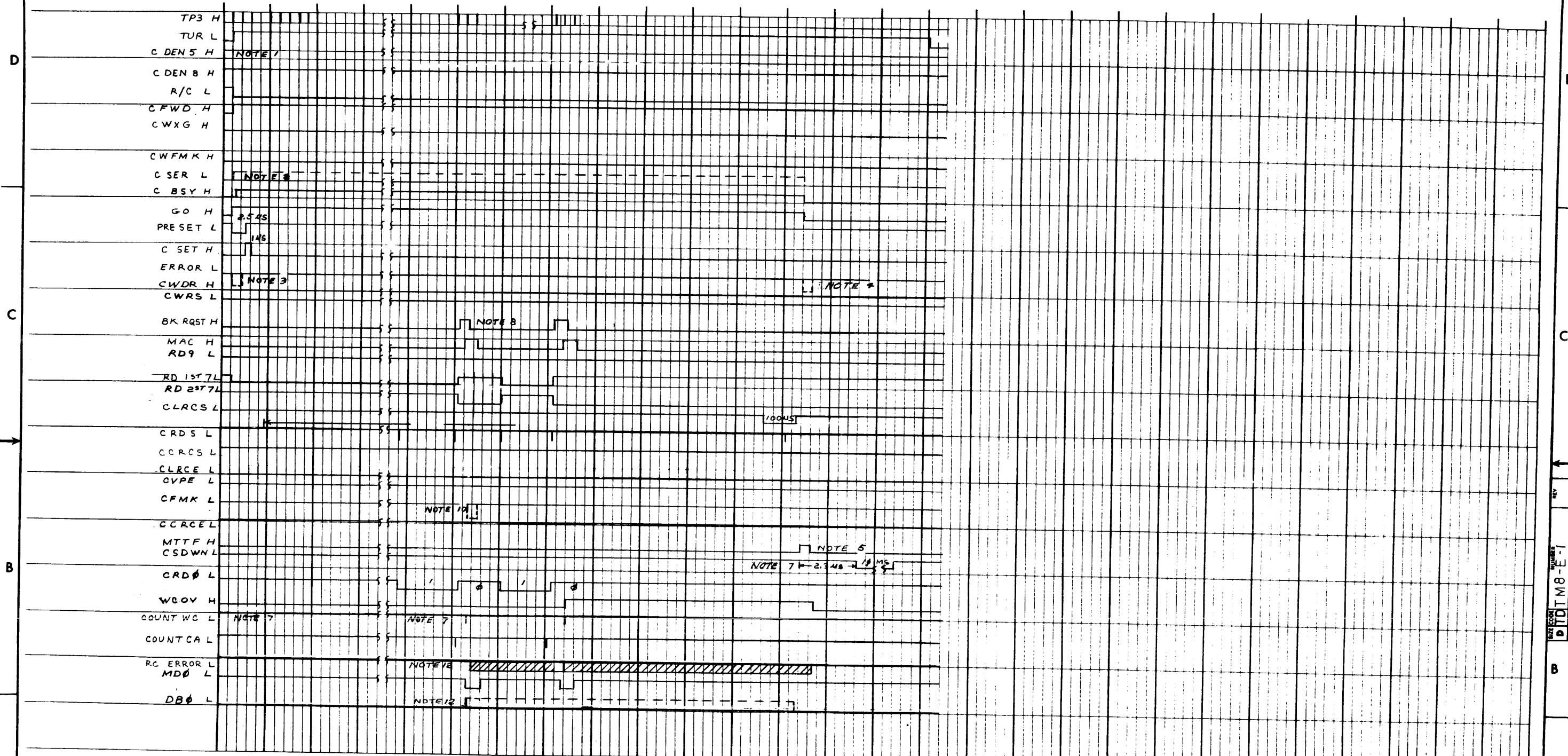

READ/COMPARE FOR NOTES SEE SHEET 9 OF 9

REV.	
CHANGE NO.	
CHK	

FIRST USED ON OPTION/MODEL TM8-E	QTY.	DESCRIPTION	PART NO.	ITEM NO.
PARTS LIST				
UNLESS OTHERWISE SPECIFIED DIMENSION IN INCHES TOLERANCES	DRB C/W/D ENG PROJ. ENG PROP.	DATE 6/24/72 DATE 10/6/72 DATE 3/21/73 DATE 4/23/73 DATE 4/24/73	digital EQUIPMENT CORPORATION MAYNARD MASSACHUSETTS	
DECIMALS .XXX = .005 .XX = .02 .X = .1	ANGLES ±0° 30'	TITLE TIMING DIAGRAM TM8-E		
REMOVE BURRS AND BREAK SHARP CORNERS SURFACE QUALITY	NEXT HIGHER ASSY. B-DD-TM8-E	SIZE CODE DTDTM8-E-1	NUMBER	REV.
MATERIAL	SCALE 2 NONE 9	DIST.		
FINISH	SHEET OF			

REC FORM NO. DRD 122

This drawing and specifications, herein, are the property of Digital Equipment Corporation and shall not be reproduced or copied or used in whole or in part as the basis for the manufacture or sale of items without written permission. COPY RIGHT © 1972 DIGITAL EQUIPMENT CORPORATION

REV. NUMBER 1-3-8-WI DITD TM8-E-1 2

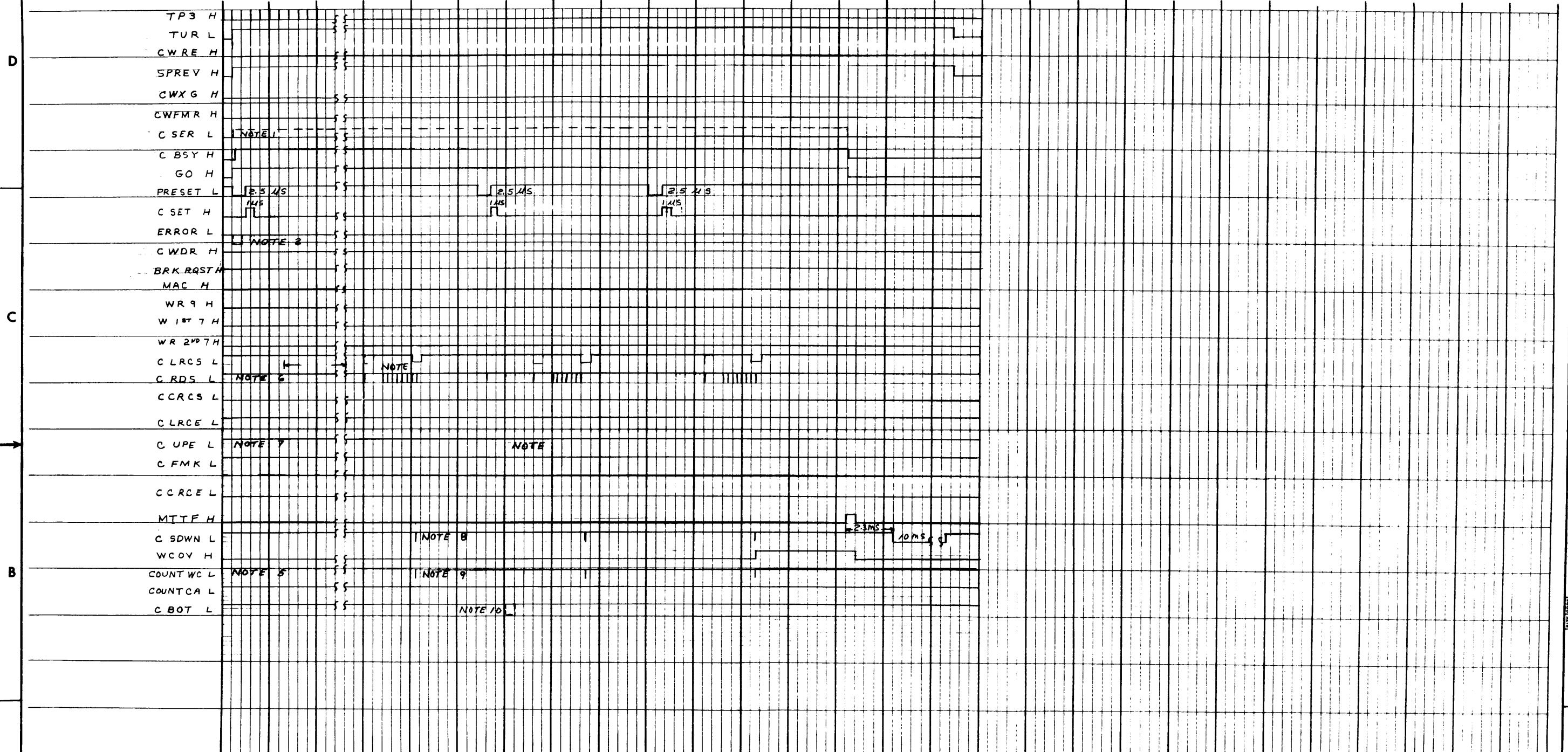

SPACE REVERSE FOR NOTES SEE SHEET 9 OF 9

REV.	
CHANGE NO.	
CHE	

DWG FORM NO. DWD 122

FIRST USED ON OPTION/MODEL TM8-E	QTY.	DESCRIPTION	PART NO.	ITEM NO.
PARTS LIST				
UNLESS OTHERWISE SPECIFIED DIMENSION IN INCHES. TOLERANCES		DRN <i>Wilson</i>	DATE 6/21/72	 digital EQUIPMENT CORPORATION MAYNARD MASSACHUSETTS
DECIMALS .XXX = .006	ANGLES ±0° 30'	CHK'D <i>[Signature]</i>	DATE 11/16/72	
.XX = .02		ENG. <i>[Signature]</i>	DATE 12/27/73	
.X = .1		PROJ. ENG. <i>[Signature]</i>	DATE 1/2/77	
REMOVE BURRS AND BREAK SHARP CORNERS SURFACE QUALITY		BRD. <i>[Signature]</i>	DATE 1/21/73	TITLE TIMING DIAGRAM TM8-E
MATERIAL + + +	NEXT HIGHER ASSY. B-DD-TM8-E	SIZE CODE DITD TM8-E-1		REV.
FINISH + + +	SCALE NONE	SHEET 3 OF 9		

This drawing and specifications, herein, are the property of Digital Equipment Corporation and shall not be reproduced or copied in whole or in part on the basis for the manufacture of any of items without written permission. COPYRIGHT © 1972 DIGITAL EQUIPMENT CORPORATION

1-3-8W 1011 a 2

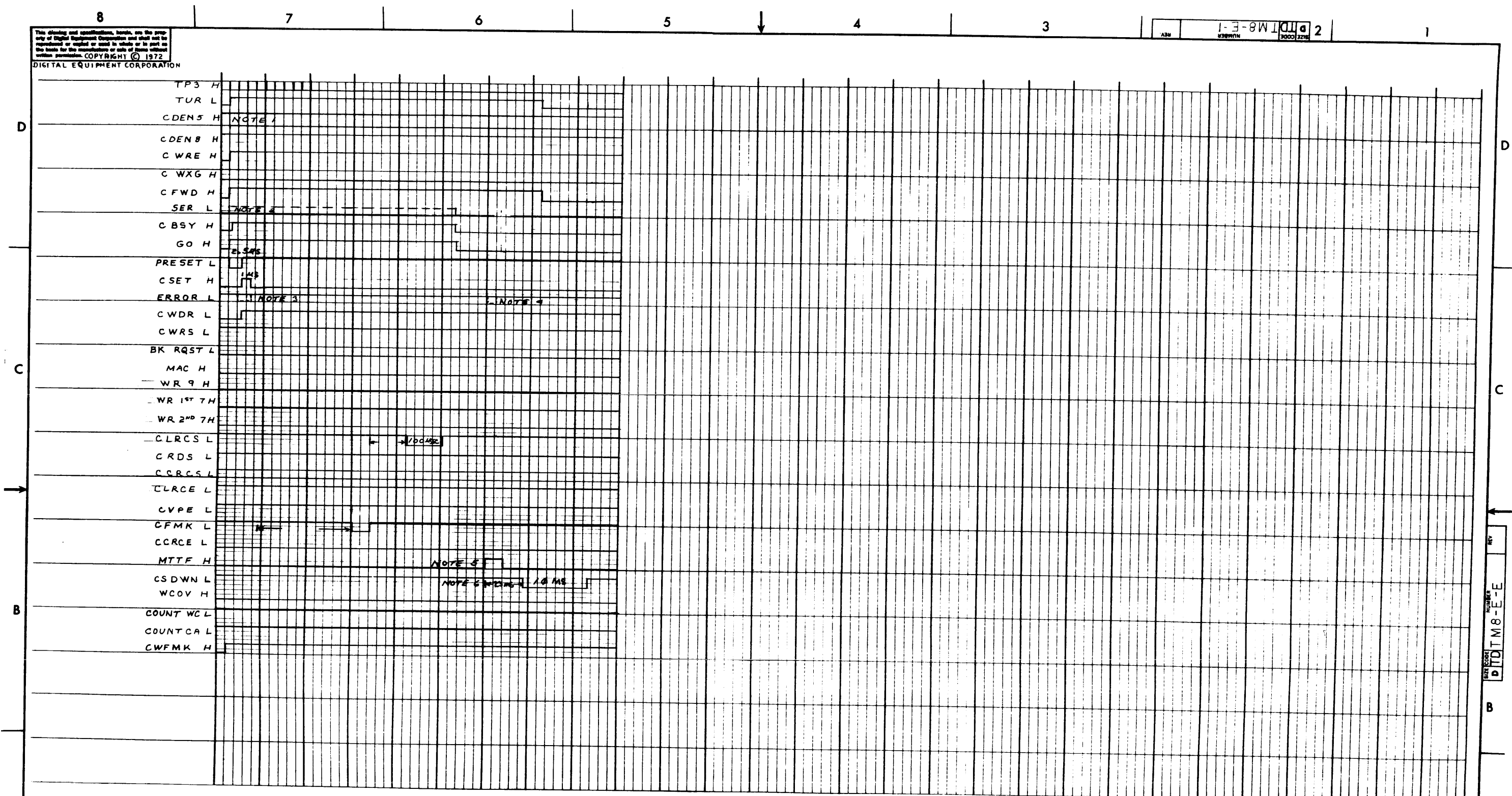

WRITE END OF FILE  
FOR NOTES SEE SHEET 9 OF 9

REV.	
CHANGE NO.	
CHK	

FIRST USED ON OPTION/MODEL TM8-E	QTY.	DESCRIPTION	PART NO.	ITEM NO.
PARTS LIST				
UNLESS OTHERWISE SPECIFIED DIMENSION IN INCHES. TOLERANCES	DRN. <i>Wilton</i>	DATE 6/22/72	digital EQUIPMENT CORPORATION MAYFELD MASSACHUSETTS	
DECIMALS .XXX = .006 .XX = .02 .X = .1	DATE 6/22/72	DATE 6/22/72	TITLE TIMING DIAGRAM TM8-E	
ANGLES 10° 30'	DATE 6/22/72	DATE 6/22/72	SIZE CODE B-DD-TM8-E	
REMOVE BURRS AND BREAK SHARP CORNERS SURFACE QUALITY	DATE 6/22/72	DATE 6/22/72	NUMBER DTDTM8-E-1	
MATERIAL	DATE 6/22/72	DATE 6/22/72	REV.	
FINISH	SCALE NONE	SHEET 4 OF 9	DIST.	

REV. NUMBER  
B-DD-TM8-E-E

This drawing and specifications, herein, are the property of Digital Equipment Corporation and shall not be reproduced or copied or used in whole or in part in any manner for the manufacture or sale of items without written permission. COPYRIGHT © 1972 DIGITAL EQUIPMENT CORPORATION

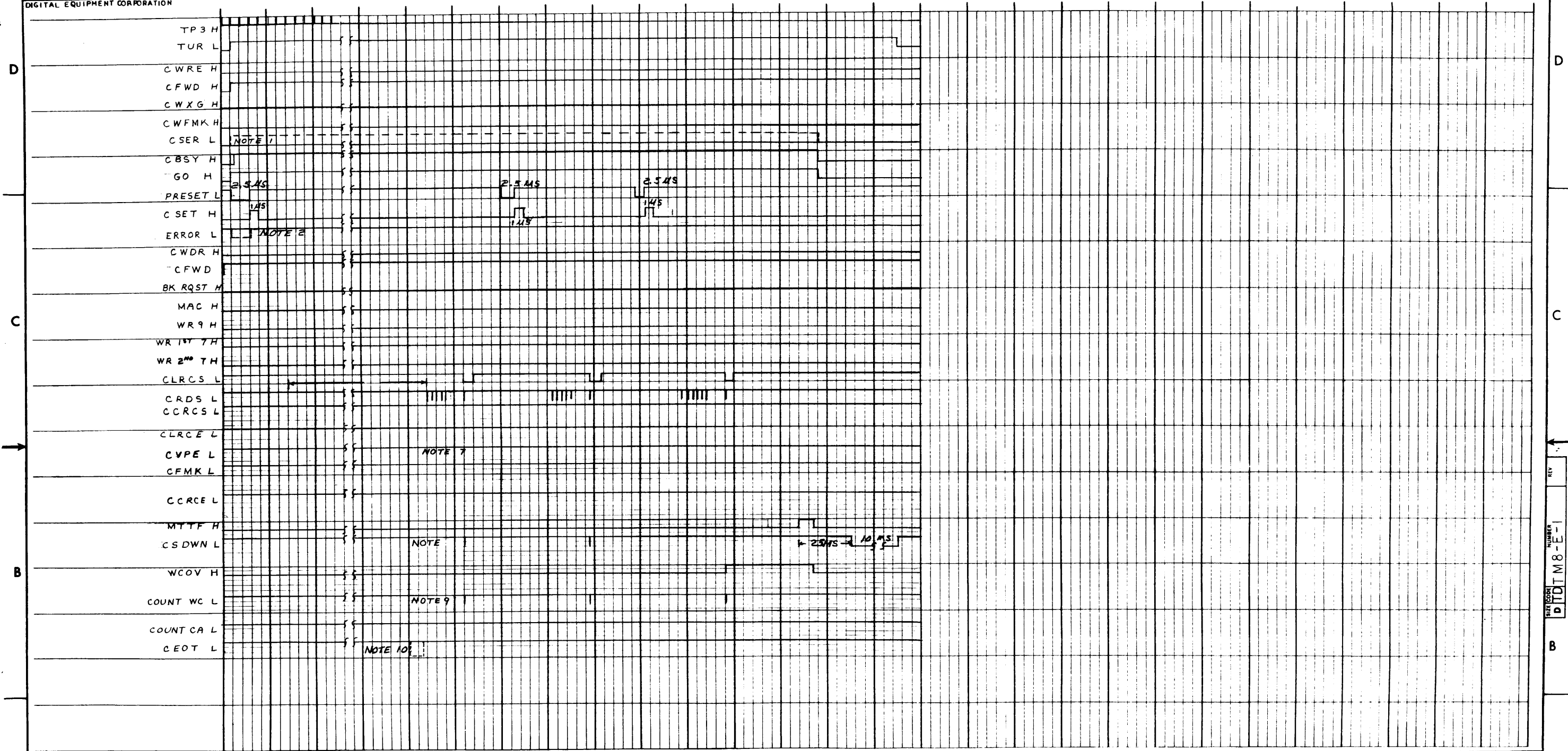

SPACE FORWARD  
 FOR NOTES SEE SHEET 9 of 9

REV.	
CHANGE NO.	
CHK	

FIRST USED ON OPTION/MODEL TM8-E	QTY.	DESCRIPTION	PART NO.	ITEM NO.
PARTS LIST				
UNLESS OTHERWISE SPECIFIED DIMENSION IN INCHES TOLERANCES	DRN. G. Wilson	DATE 6/22/72	digital EQUIPMENT CORPORATION MAYNARD MASSACHUSETTS	
DECIMALS .XXX = .006 XX = .02 .X = .1	ENG. G. Wilson	DATE 4/23/72	TITLE TIMING DIAGRAM TM8-E	
ANGLES ±0° 30'	PREL. ENG. G. Wilson	DATE 4/23/72	SIZE CODE B-DD-TM8-E	
REMOVE BURRS AND BREAK SHARP CORNERS SURFACE QUALITY	PREP. G. Wilson	DATE 4/23/72	NUMBER DTD TM8-E-1	
MATERIAL	NEXT HIGHER ASSY. B-DD-TM8-E		SCALE NONE	REV.
FINISH	SHEET 5 OF 9		DIST.	

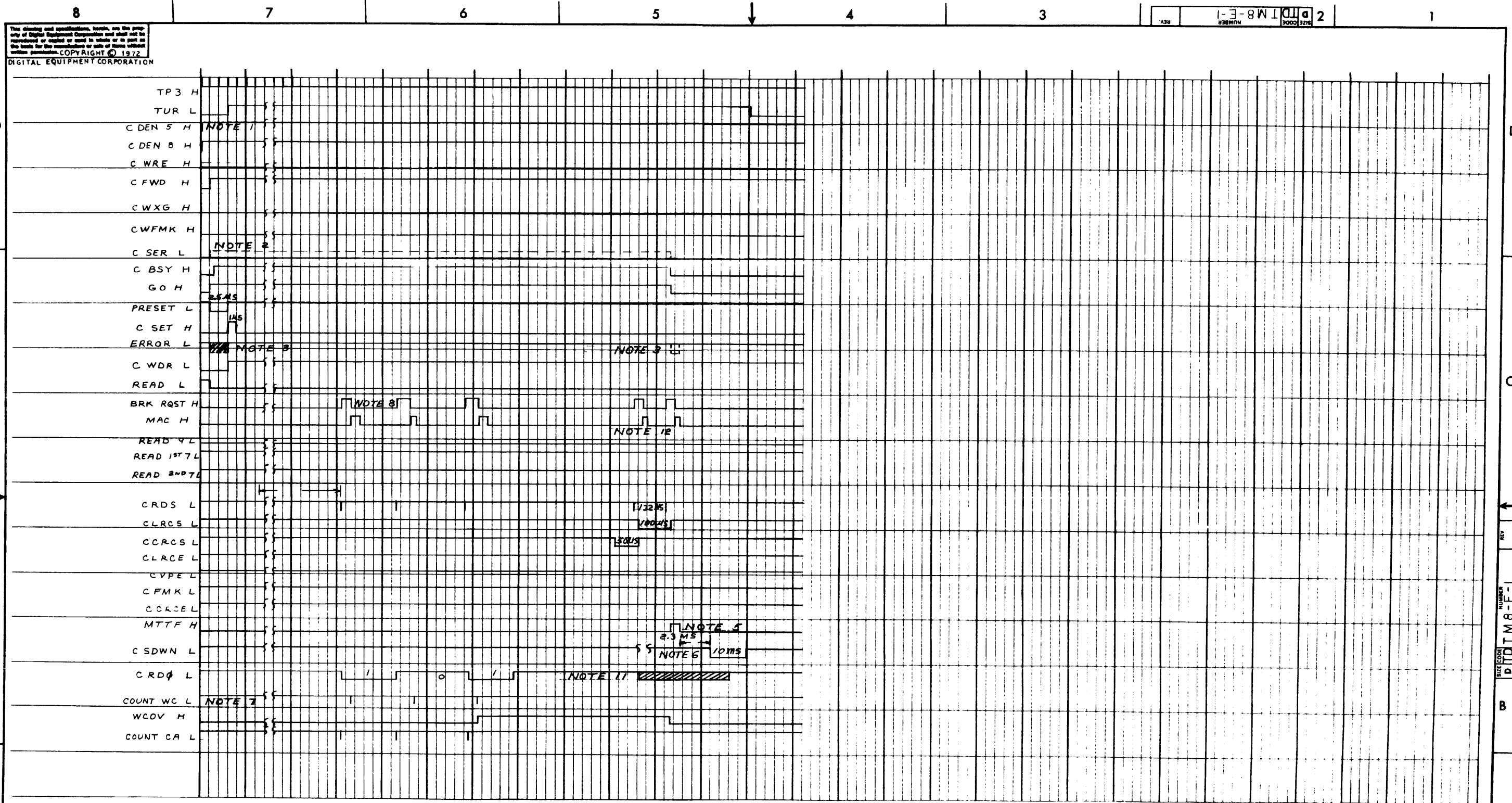

This drawing and specifications herein are the property of Digital Equipment Corporation and shall not be reproduced or copied or used in whole or in part on any basis for the manufacture or sale of items without written permission. COPYRIGHT © 1972 DIGITAL EQUIPMENT CORPORATION

REV. NUMBER 1-3-81 2

NOTE:  
LCR AND CRC CHARACTERS DETERMINES WHAT IS READ FROM RDO AT THIS TIME.

READ 9 TRACK  
FOR NOTES SEE SHEET 9 OF 9

FIRST USED ON OPTION/MODEL	QTY.	DESCRIPTION	PART NO.	ITEM NO.
TMB-E				
UNLESS OTHERWISE SPECIFIED DIMENSION IN INCHES. TOLERANCES				
DECIMALS	ANGLES	PARTS LIST		
.XXX - .006	±0° 30'	DRN. <i>S. Wilson</i>	DATE <i>6/27/72</i>	<p>TITLE TIMING DIAGRAM TM8-E</p>
.XX - .02		CHVD. <i>Wilson</i>	DATE <i>7/16/72</i>	
.X - .1		ENG. <i>Wilson</i>	DATE <i>8/23/72</i>	
		PROJ. ENG.	DATE <i>1/27/73</i>	
		PROD.	DATE <i>4/7</i>	
MATERIAL	NEXT HIGHER ASSY.	<p>REMOVE BURRS AND BREAK SHARP CORNERS SURFACE QUALITY ✓</p>		
FINISH	B-DD-TMB-E	<p>SCALE NONE</p>		
		SHEET 6 OF 9		REV.

REV.	
CHANGE NO.	
REVISIONS	



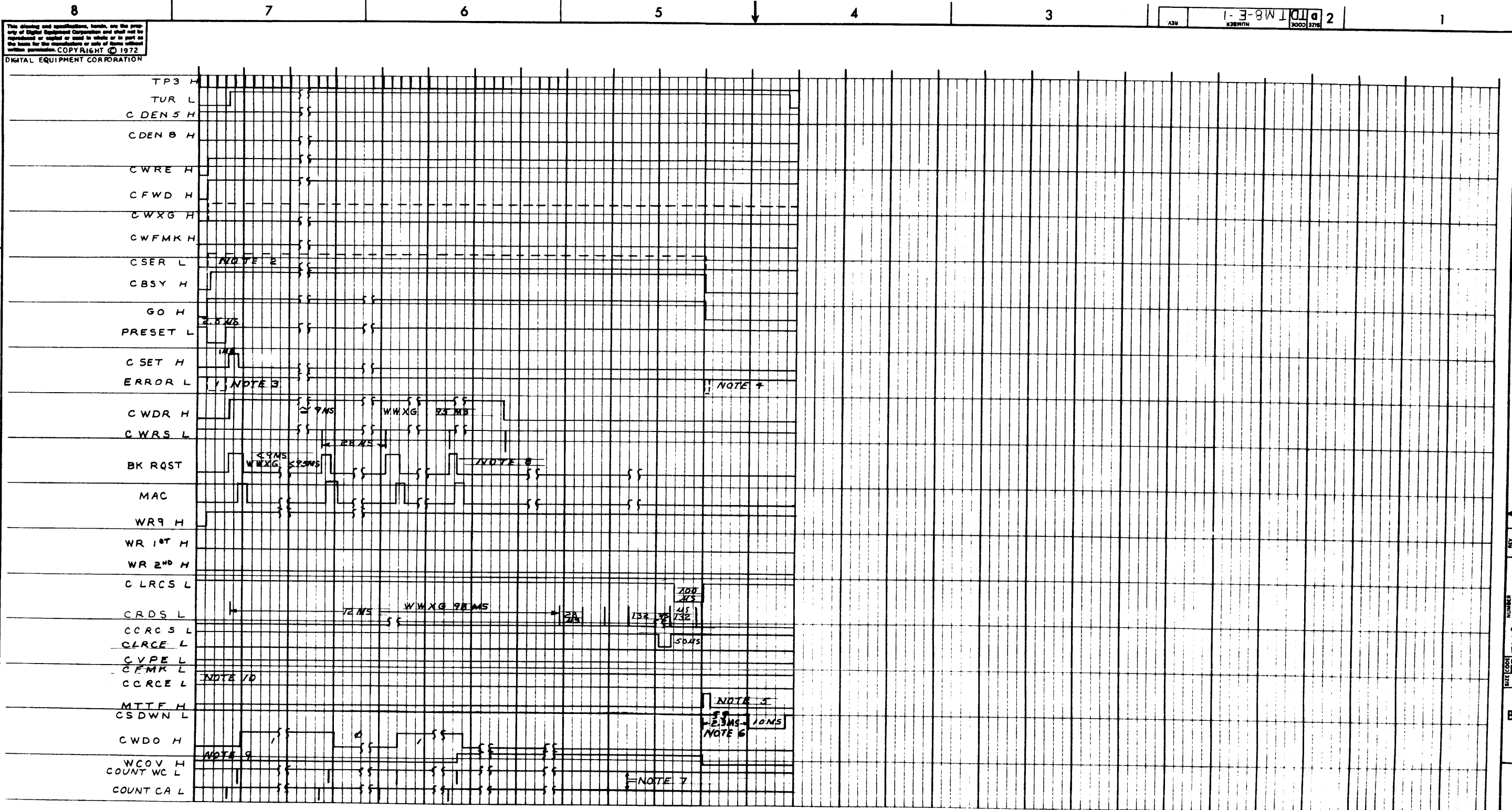

WRITE 9 TRACK  
FOR NOTES SEE SHEET 9 OF 9

REV.	
CHANGE NO.	
CHK	

FIRST USED ON OPTION/MODEL TM8-E	QTY.	DESCRIPTION	PART NO.	ITEM NO.
PARTS LIST				
UNLESS OTHERWISE SPECIFIED DIMENSION IN INCHES. TOLERANCES		DRN <i>E. Wilson</i>	DATE 6/28/72	 <b>digital</b> EQUIPMENT CORPORATION MAYNARD, MASSACHUSETTS
DECIMALS	ANGLES	ENG. <i>[Signature]</i>	DATE 6/28/72	
.XXX - .005	±0° 30'	PROJ. ENG.	DATE 7/1/72	
.XX - .02		PROD.	DATE 7/1/72	
REMOVE BURRS AND BREAK SHARP CORNERS SURFACE QUALITY		PROD. <i>[Signature]</i>	DATE 7/1/72	TITLE TIMING DIAGRAM TM8-E
MATERIAL	NEXT HIGHER ASSY.		SCALE	NUMBER
+	B-DD-TM8-E		NONE	DTD TM8-E-1
FINISH	SHEET 9 OF 9		DIST.	REV.

This drawing and specifications herein are the property of Digital Equipment Corporation and shall not be reproduced or copied or used in whole or in part as the basis for the manufacture or sale of items without written permission. COPYRIGHT © 1972  
DIGITAL EQUIPMENT CORPORATION

**READ 7 TRACK**

NOTE 1. C SER L (SELECT REMOTE) WHEN THE SELECTED TRANSPORT IS ON LINE.

NOTE 2. IF THE ERROR FLAG IS SET AT THE BEGINNING OF AN OPERATION BY A SELECT ERROR THE OPERATION STOPS.

NOTE 3. THE TMO-E IGNORES THE ERROR FLAG UNTIL THE OPERATION IN PROGRESS IS COMPLETED. THE STATUS REGISTERS MUST BE READ BY THE PROGRAM TO DETERMINE WHAT CAUSED THE ERROR.

NOTE 4. MTF REMAINS SET UNTIL IT IS CLEARED BY THE PROGRAM.

NOTE 5. WRITE SHUT DOWN TIME IS 2.3MS..

NOTE 6. COUNT CA AND COUNT WC PULSES ARE 100 NS

NOTE 7. TP3 ENABLES BRK RQST LOGIC WHEN TMO-E HAS HIGHEST PRIORITY. LENGTH OF PULSE DETERMINED BY TIME IT OCCURS IN RELATION TO TP3 AND THE NUMBER OF PERIPHERALS WITH HIGHER PRIORITY THAN THE TMO-E MAKING BREAK REQUESTS.

NOTE 8. THE OTHER PARALELL LINES ARE IDENTICAL TO RDO.

NOTE 9. IF A FILE MARK (EOF) IS DETECTED THE OPERATION STOPS.

NOTE 10. UNKNOWN DATA.

NOTE 11. AN ADDITIONAL SINGLE CYCLE DATA BREAK IS PERFORMED AFTER WORD COUNT OVERFLOW TO TRANSFER THE LRCS CHARACTER TO MEMORY IF BIT 4 IN THE FUNCTION REGISTER IS A ONE (SEE TABLE 3-2).

**READ/COMPARE**

NOTE 1. C SER L (SELECT REMOTE) WHEN THE SELECTED TRANSPORT IS ON LINE.

NOTE 2. IF THE ERROR FLAG IS SET AT THE BEGINNING OF AN OPERATION BY A SELECT ERROR THE OPERATION STOPS.

NOTE 3. THE TMO-E IGNORES THE ERROR FLAG UNTIL THE OPERATION IN PROGRESS IS COMPLETED. THE STATUS REGISTERS MUST BE READ BY THE PROGRAM TO DETERMINE WHAT CAUSED THE ERROR.

NOTE 4. MTF REMAINS SET UNTIL IT IS CLEARED BY THE PROGRAM.

NOTE 5. WRITE SHUT DOWN TIME IS 2.3MS.

NOTE 6. COUNT CA AND COUNT WC PULSES ARE 100 NS

NOTE 7. TP3 ENABLES BRK RQST LOGIC WHEN TMO-E HAS HIGHEST PRIORITY. LENGTH OF PULSE DETERMINED BY TIME IT OCCURS IN RELATION TO TP3 AND THE NUMBER OF PERIPHERALS WITH HIGHER PRIORITY THAN THE TMO-E MAKING BREAK REQUESTS.

NOTE 8. THE OTHER PARALELL LINES ARE IDENTICAL TO RDO.

NOTE 9. IF A FILE MARK (EOF) IS DETECTED THE OPERATION STOPS.

NOTE 10. IF A READ/COMPARE ERROR IS DETECTED THE READ/COMPARE OPERATION STOPS AND THE CA REGISTER CONTAINS THE ADDRESS OF THE DATA THAT PRODUCED THE ERROR. TAPE MOTION CONTINUES UNTIL WC OVERFLOW OCCURS OR AN EOF IS DETECTED.

NOTE IF MDO AND DBO ARE DIFFERENT RIC ERROR IS GENERATED BY THE READ/COMPARE LOGIC.

**SPACE FORWARD**

NOTE 1. C SER L (SELECT REMOTE) IS ASSERTED WHEN SELECTED TRANSPORT IS ON LINE.

NOTE 2. SEE TABLE 3-3 BIT# , ERROR FLAG.

NOTE 3. SEE TABLE 3-3 BIT# , ERROR FLAG.

NOTE 4. MTF REMAINS SET UNTIL THE PROGRAM EXECUTES A CLF INSTRUCTION TO CLEAR ALL FLAGS.

NOTE 5. COUNT WC PULSES ARE 100 NS.

NOTE 6. CROSL PULSES OCCUR AFTER EACH CHARACTER IS READ FROM THE TAPE BUT HAVE NO AFFECT ON THE SPACE OPERATION.

NOTE 7. VPE LOGIC IS DISABLED IN THE TMO-E DURING A SPACE OPERATION.

NOTE 8. C SDWN L IS ASSERTED FOR APPROXIMATELY 100 NSEC EACH TIME A C LRC S PULSE IS GENERATED AT THE END OF A RECORD.

NOTE 9. WORD COUNT IS INCREMENTED AFTER EACH RECORD DURING A SPACE OPERATION.

NOTE 10. IF EOT IS DETECTED BY THE TUIØ THE OPERATION STOPS.

**SPACE REVERSE**

NOTE 1. C SER L (SELECT REMOTE) IS ASSERTED WHEN SELECTED TRANSPORT IS ON LINE.

NOTE 2. SEE TABLE 3-3 BIT# , ERROR FLAG.

NOTE 3. SEE TABLE 3-3 BIT# , ERROR FLAG.

NOTE 4. MTF REMAINS SET UNTIL THE PROGRAM EXECUTES A CLF INSTRUCTION TO CLEAR ALL FLAGS.

NOTE 5. COUNT WC PULSES ARE 100NS

NOTE 6. CROSL PULSES OCCUR AFTER EACH CHARACTER IS READ FROM THE TAPE BUT HAVE NO AFFECT IN THE SPACE OPERATION.

NOTE 7. VPE LOGIC IS DISABLED IN THE TMO-E DURING A SPACE OPERATION.

NOTE 8. C SDWN L IS ASSERTED FOR APPROXIMATELY 100 M SEC EACH TIME A C LRC S PULSE IS GENERATED AT THE END OF A RECORD

NOTE 9. WORD COUNT IS INCREMENTED AFTER EACH RECORD DURING A SPACE OPERATION

NOTE 10. IF BOT IS DETECTED BY THE TUIØ THE OPERATION STOPS.

**WRITE 7 TRACK**

NOTE 1. C SER L (SELECT REMOTE) WHEN THE SELECTED TRANSPORT IS ON LINE.

NOTE 2. IF THE ERROR FLAG IS SET AT THE BEGINNING OF AN OPERATION BY A SELECT ERROR THE OPERATION STOPS.

NOTE 3. THE TMO-E IGNORES THE ERROR FLAG UNTIL THE OPERATION IN PROGRESS IS COMPLETED. THE STATUS REGISTERS MUST BE READ BY THE PROGRAM TO DETERMINE WHAT CAUSED THE ERROR.

NOTE 4. MTF REMAINS SET UNTIL IT IS CLEARED BY THE PROGRAM.

NOTE 5. WRITE SHUT DOWN TIME IS 2.3MS.

NOTE 6. COUNT CA AND COUNT WC PULSES ARE 100 NS

NOTE 7. TP3 ENABLES BRK RQST LOGIC WHEN TMO-E HAS HIGHEST PRIORITY. LENGTH OF PULSE DETERMINED BY TIME IT OCCURS IN RELATION TO TP3 AND THE NUMBER OF PERIPHERALS WITH HIGHER PRIORITY THAN THE TMO-E MAKING BREAK REQUESTS.

NOTE 8. THE OTHER PARALELL LINES ARE IDENTICAL TO RDO.

NOTE 9. IF A FILE MARK (EOF) IS DETECTED THE OPERATION STOPS.

NOTE 10. THESE PULSES ARE SEEN ONLY IF THE OPERATION IS LONG ENOUGH TO ALLOW THE TAPE TO MOVE FROM WRITE HEAD TO READ HEAD OR TAPE CONTINUES TO MOVE FORWARD AS IN CONTINUOUS MODE OF OPERATION

**WRITE 9 TRACK**

NOTE 1. C SER L (SELECT REMOTE) WHEN THE SELECTED TRANSPORT IS ON LINE.

NOTE 2. IF THE ERROR FLAG IS SET AT THE BEGINNING OF AN OPERATION BY A SELECT ERROR THE OPERATION STOPS.

NOTE 3. THE TMO-E IGNORES THE ERROR FLAG UNTIL THE OPERATION IN PROGRESS IS COMPLETED. THE STATUS REGISTERS MUST BE READ BY THE PROGRAM TO DETERMINE WHAT CAUSED THE ERROR.

NOTE 4. MTF REMAINS SET UNTIL IT IS CLEARED BY THE PROGRAM.

NOTE 5. WRITE SHUT DOWN TIME IS 2.3MS.

NOTE 6. COUNT CA AND COUNT WC PULSES ARE 100 NS.

NOTE 7. TP3 ENABLES BRK RQST LOGIC WHEN TMO-E HAS HIGHEST PRIORITY. LENGTH OF PULSE DETERMINED BY TIME IT OCCURS IN RELATION TO TP3 AND THE NUMBER OF PERIPHERALS WITH HIGHER PRIORITY THAN THE TMO-E MAKING BREAK REQUESTS.

NOTE 8. THE OTHER PARALELL LINES ARE IDENTICAL TO RDO.

NOTE 9. IF A FILE MARK (EOF) IS DETECTED THE OPERATION STOPS.

**END OF FILE**

NOTE 1. SEE TABLE 3-1 AND FIGURE 3-2 AS SHOWN A DENSITY OF 800 BPI IS SELECTED.

NOTE 2. C SER L (SELECT REMOTE) IS ASSERTED WHEN THE SELECTED TRANSPORT IS ON LINE.

NOTE 3. IF THE ERROR FLAG IS SET AT THE BEGINNING OF AN OPERATION BY A SELECT ERROR THE OPERATION STOPS.

NOTE 4. THE TMO-E IGNORES THE ERROR FLAG UNTIL THE OPERATION IN PROGRESS IS COMPLETED. THE STATUS REGISTER MUST BE READ BY THE PROGRAM TO DETERMINE WHAT CAUSED THE ERROR.

NOTE 5. MTF REMAINS SET UNTIL IT IS CLEARED BY THE PROGRAM.

NOTE 6. WRITE SHUT DOWN TIME IS 2.3MS.

BRUNING 40-07 15848  
REV  
CHANGE NO  
CHK

FIRST USED ON OPTION/MODEL	QTY.	DESCRIPTION	PART NO.	ITEM NO.
TMS-E				
PARTS LIST				
UNLESS OTHERWISE SPECIFIED DIMENSION IN INCHES. TOLERANCES	DRN 4/2/72	DATE	digital EQUIPMENT CORPORATION MAYNARD, MASSACHUSETTS	
DECIMALS .008 XX .02 X .1	CHK'D. 4/2/72	DATE	TITLE TIMING DIAGRAM TMS-E	
ANGLES ±0° 30'	ENG. 4/2/72	DATE	SIZE CODE NUMBER D TMS-E-1	
REMOVE BURRS AND BREAK SHARP CORNERS SURFACE QUALITY	PROJ. ENG. 4/2/72	DATE	REV.	
MATERIAL	PROD.	DATE	NEXT HIGHER ASSY B-DD-TMS-E	
FINISH	SCALE NON F		SHEET 9 OF 9	
			DIST	

REV  
NUMBER  
D TMS-E-1





This drawing and specifications, herein, are the property of Digital Equipment Corporation and shall not be reproduced or copied or used in whole or in part as the basis for the manufacture or sale of items without written permission.

**DIGITAL EQUIPMENT CORPORATION**  
MAYNARD, MASSACHUSETTS

**ENGINEERING SPECIFICATION**

DATE 9/28/72

TITLE TM8-E SPECIFICATIONS FOR THE MAGNETIC TAPE CONTROL

REVISIONS

REV	DESCRIPTION	CHG NO	ORIG	DATE	APPD BY	DATE
A	ELIMINATE BAD TAPE	TM8E 00001	CZAJKOWSKI	4/73	<i>[Signature]</i>	9/28/72

ENG A. Czajkowski	APPD <i>[Signature]</i>	SIZE A	CODE SP	NUMBER TM8-E-4	REV A
----------------------	----------------------------	-----------	------------	-------------------	----------

DEC FORM NO.  
DRA 107

**ENGINEERING SPECIFICATION**

**digital**

CONTINUATION SHEET

TITLE TM8-E SPECIFICATIONS FOR THE MAGNETIC TAPE CONTROL

1.0 General Description

The TM8-E control provides the interface between the PDP8/E and the TU10 master-slave magnetic tape transport system. The TU10 master can control eight (8) slaves, so the TM8-E is capable of controlling eight (8) transports.

The data transfer is via single cycle data break with a transfer rate of 36K Hz. The transport operates at 45 ips and uses 7 channel formats at 200, 556 or 800 bpi, or 9 channel format at 800 bpi.

1.1 Hardware Description

The TM8-E consists of four quad modules:

- M8321 TM8-E Output Control
- M8322 TM8-E Control and Break
- M8323 TM8-E Transport Status Control
- M8327 TM8-E Registers
- M989 Terminator board plugs into TU10 (A6) and two BC08L cables not to exceed 15 feet.

The four quad modules will plug into the OMNIBUS as per PDP8/E option priority designation list. The priority of the TM8-E module must be one of two ways.

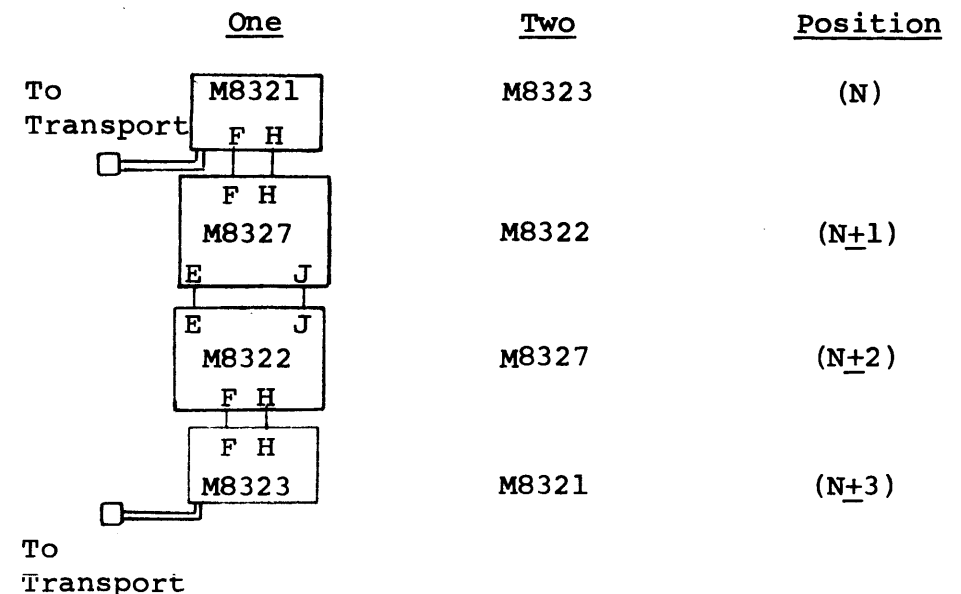

DEC FORM NO DEC 16-(381)-1022-N370  
DRA 108

SIZE A	CODE SP	NUMBER TM8-E-4	REV A
-----------	------------	-------------------	----------

TITLE TMS-E SPECIFICATIONS FOR THE MAGNETIC TAPE CONTROL

The signals needed to communicate between boards pass through top connectors. The signals needed to communicate with the transport pass through the connector located on the upper left corner of the modules M8323 and M8321.

2.0 Electrical Requirements

The power requirement is as follows:

M8321	+5V	1000	MA
M8322	+5V	775	MA
M8323	+5V	900	MA
M8327	+5V	1500	MA
Total	+5V	4175	MA

No power will be supplied to the transport from the TMS-E.

3.0 Environment

Temperature:	A. Operating	45°F - 95°F
	B. Non-operating	-30°F - 150°F
Humidity:	A. Operating	20% - 80% with no condensation.
	B. Non-operating	5% - 95%

4.0 Software Documents

The following diagnostics and programs are available for the TMS-E:

1. TMS-E Control Test Part 1 MAINDEC-08-DHTMA-A
2. TMS-E Control Test Part 2 MAINDEC-08-DHTMB-A
3. Drive Function Timer, MAINDEC-08-DHTML-A
4. TMS-E Data Reliability Test - 9 Track, MAINDEC-08-DTMD-A
5. TMS-E Data Reliability Test- 7 Track, MAINDEC-08-DTME-A
6. TMS-E Random Exerciser, MAINDEC-08-DHTMF-A
7. TMS-E DEC Magtape System Module for DEC/8X, MAINDEC-8X-DHTMA-A

SIZE	CODE	NUMBER	REV
A	SP	TMS-E-4	A

TITLE TMS-E SPECIFICATIONS FOR THE MAGNETIC TAPE CONTROL

5.0 Instructions

- 6701 LWCR Load Word Count Register & Clear the AC  
AC → WC, 0 → AC
- 6702 CWCR Clear Word Count Register
- 6703 LCAR Load Current Address Register & Clear the AC  
AC → CA, 0 → AC
- 6704 CCAR Clear Current Address
- 6705 LCMR Load Command Register & Clear the AC  
AC → CM, 0 → AC

Command Register Bits

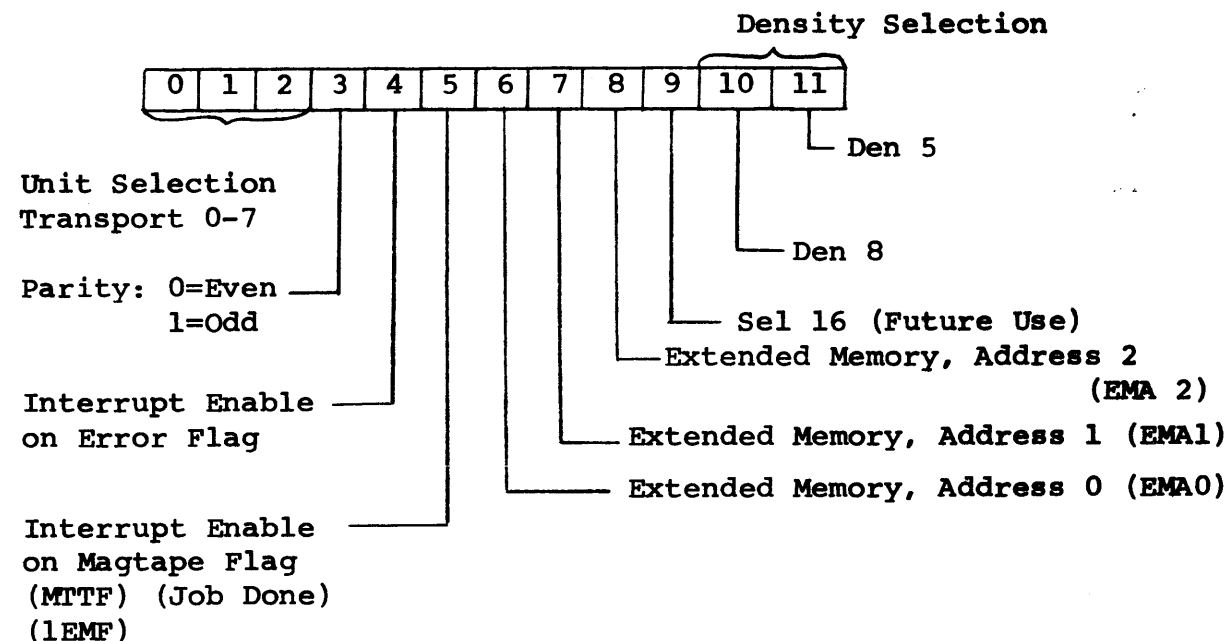

- 6706 LFGR Load Function Register (GO bit) & Clear AC  
AC → Function Register 0 → AC

SIZE	CODE	NUMBER	REV
A	SP	TMS-E-4	A

TITLE TM8-E SPECIFICATIONS FOR THE MAGNETIC TAPE CONTROL

Function Register

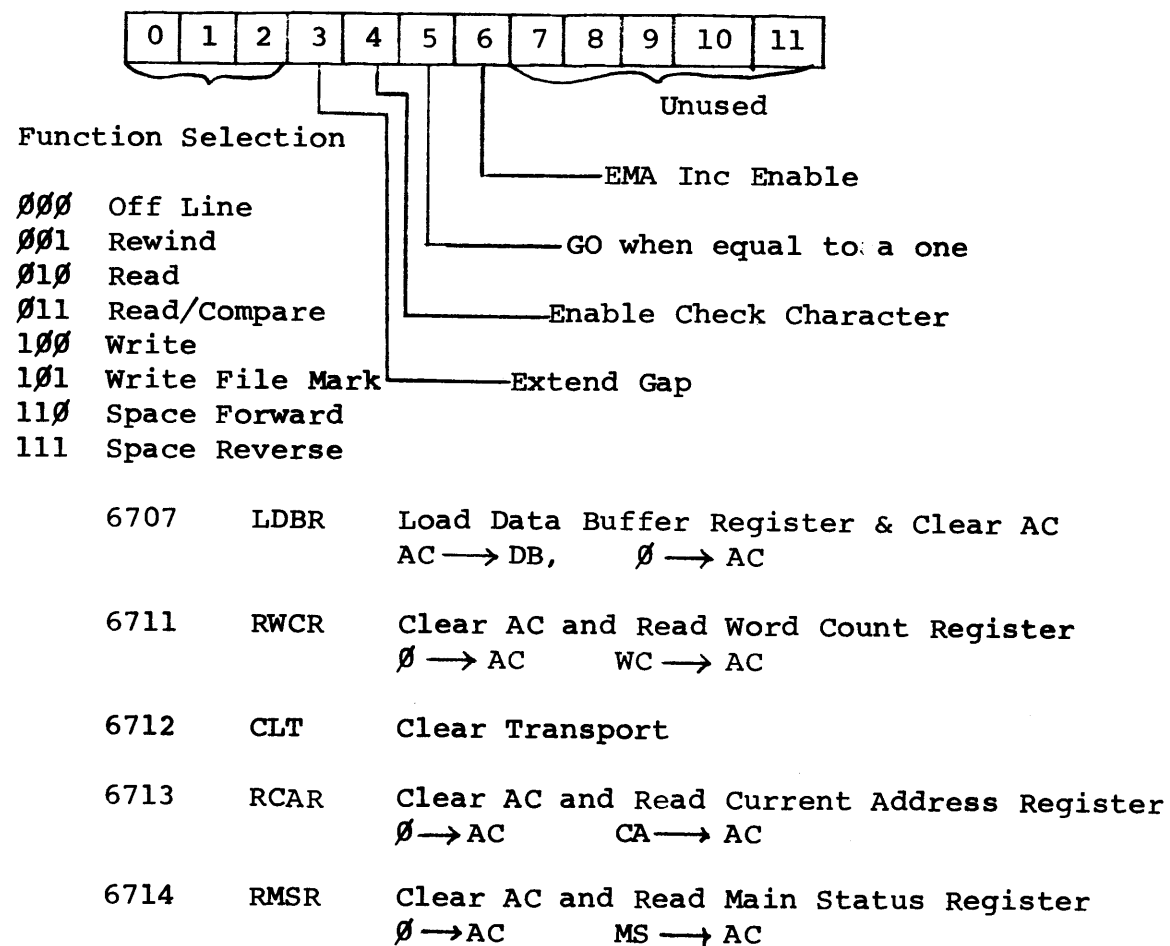

TITLE TM8-E SPECIFICATIONS FOR THE MAGNETIC TAPE CONTROL

Main Status Register Bits

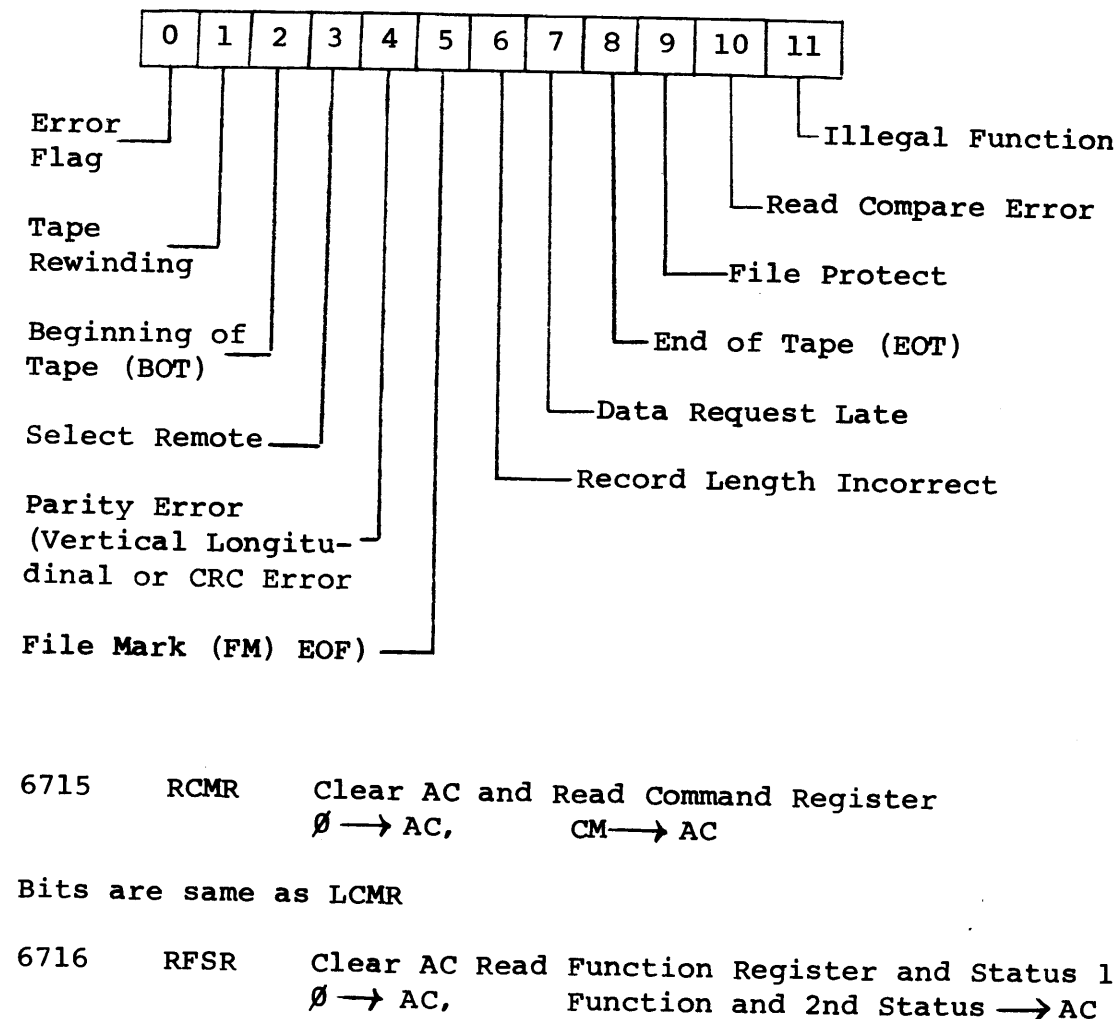

**ENGINEERING SPECIFICATION**

CONTINUATION SHEET

TITLE TMS-E SPECIFICATIONS FOR THE MAGNETIC TAPE CONTROL

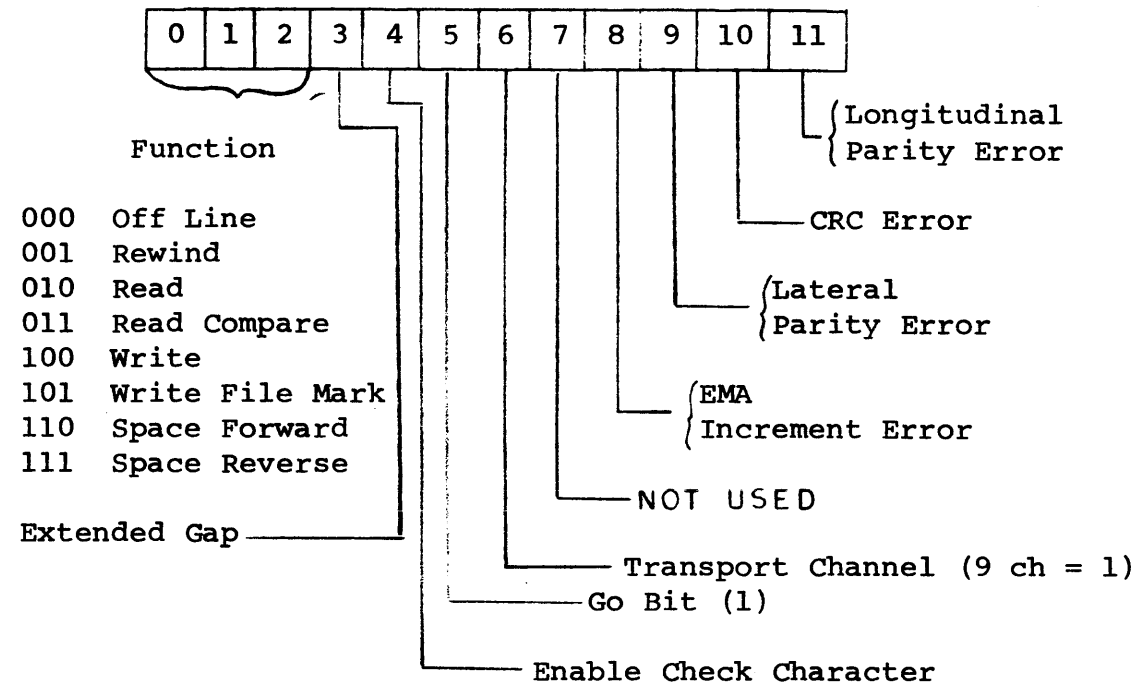

- 000 Off Line
- 001 Rewind
- 010 Read
- 011 Read Compare
- 100 Write
- 101 Write File Mark
- 110 Space Forward
- 111 Space Reverse

- Extended Gap
- 6717 RDBR Clear AC Read Data Buffer  
∅ → AC, DB → AC
- 6721 SKEF Skip if error flag is set  
+1 → PC
- 6722 SKCB Skip if Control is not busy  
+1 → PC
- 6723 SKJD Skip if the job is done (MTTF is set)  
+1 → PC
- 6724 SKTR Skip if tape unit is ready  
+1 → PC
- 6725 CLF Clear the Controller and Transport Master if  
TUR, if not clear MTF, EF and Status Registers.  
∅ → Control Registers
- 6726 CKDL Check for Data Late Error
- 6727 SBRM Set Break Request for one Data Break  
1 → BR

SIZE CODE NUMBER REV  
A SP TMS-E-4 A

**ENGINEERING SPECIFICATION**

CONTINUATION SHEET

TITLE TMS-E SPECIFICATIONS FOR THE MAGNETIC TAPE CONTROL

Instructions and Status Bits

The following instructions are used to program the TMS-E. Refer to the appropriate table for the status bits associated with each instruction.

Load Word Count Register (LWCR)

Octal Code: 6701

Operation: Load the Word Count Register with the contents of the AC and clear the AC. The Word Count Register should not be loaded when the control is busy. If the register is loaded during Control Busy data reliability tape compatibility are not assured. The word count is loaded with the 2's complement of the number of words to be transferred or number of blocks to be spaced. The Word Count Register is incremented at TPl of a Data Break Cycle during data transfers, at LRCS during a Space Forward; or at the first word of a record during a Space Reverse operation.

Recommended block length is per USA Standards, Document USAS X3.22-1967, Recorded Magnetic Tape for information interchange (800 cpi, NRZ1).

Clear Word Count Register (CWCR)

Octal Code: 6702

Operation: Clear the Word Count Register. This instruction is used primarily in maintenance operations and should never be used during Control Busy (CNTL BSY).

SIZE CODE NUMBER REV  
A SP TMS-E-4 A

**ENGINEERING SPECIFICATION**

CONTINUATION SHEET

TITLE TMS-E SPECIFICATIONS FOR THE MAGNETIC TAPE CONTROL

Load Current Address Register (LCAR)

Octal Code: 6703

Operation: Load the Current Address Register with the contents of the AC and clear the AC. The Current Address Register is loaded to one less than the memory address of the first word to be transferred. If this instruction is executed during Control Busy, one of the following occurs:

1. In the wrap around modes (Function bit 6=0) location of the data transfer cannot be assured within the selected memory field.
2. In the EMA INC ENABLE MODE (Function Bit 6=1) location of the data transfer cannot be assured within memory. The current Address Register is incremented at each BRK RQST.

Clear Current Address Register (CCAR)

Octal Code: 6704

Operation: Clear the Current Address Register. This instruction is used primarily for maintenance and should never be used during Control Busy.

SIZE A	CODE SP	NUMBER TMS-E-4	REV A
-----------	------------	-------------------	----------

**ENGINEERING SPECIFICATION**

CONTINUATION SHEET

TITLE TMS-E SPECIFICATIONS FOR THE MAGNETIC TAPE CONTROL

Load Command Register (LCMR):

Octal Code: 6705

Operation: Load the Command Register with contents of the AC and clear the AC. This instruction must not be issued during Control Busy. The LCMR instruction selects tape transport, Parity mode, enables or disables interrupts, selects a memory field, and recording densities.

Command Register Contents and Function

Bit No.	Function		
Bits 0,1 & 2	Unit selection of transports 0 through 7 as shown.		
	SEL 0 Bit 0	SEL 1 Bit 1	SEL 2 Bit 2
	0	0	0
	0	0	1
	0	1	0
	0	1	1
	1	0	0
	1	0	1
	1	1	0
	1	1	1
Bit 3	0 = Even Parity 1 = Odd Parity		
Bit 4	If Bit 4 is a one, enable Interrupt on Error flag.		
Bit 5	Enable interrupt on job done (MTTF) if Bit 5 is a one.		
Bits 6,7, & 8	Extended Memory Address (EMA), these bits determine which memory field the controller uses for data transfer operations during a data break. Function Register bit 6 determines if EMA address is to be incremented or used in the wrap around mode.		

SIZE A	CODE SP	NUMBER TMS-E-4	REV A
-----------	------------	-------------------	----------

**ENGINEERING SPECIFICATION**

CONTINUATION SHEET

TITLE TMS-E SPECIFICATIONS FOR THE MAGNETIC TAPE CONTROL

Bit 6 Bit 7 Bit 8  
(EMA0) (EMA1) (EMA2)

0	0	0	Field 0
0	0	1	Field 1
0	1	0	Field 2
0	1	1	Field 3
1	0	0	Field 4
1	0	1	Field 5
1	1	0	Field 6
1	1	1	Field 7

Bit 9 Reserved for future use.

Bits 10 & 11 Density Bits, these bits select the density for tape transport operation and are referred to as Den 8 (bit 10) and Den 5 (bit 11).

Bits 10 and 11 select the tape density and core dump on 9 channel transports.

Bit 10 Bit 11  
Den 8 Den 5

0	0	200 bpi, 7 channel
0	1	556 bpi, 7 channel
1	0	*800 bpi, 7 channel
1	1	800 bpi, 9 channel

\*This mode is also referred to as Core Dump Mode. When this command is issued to a 9-channel transport zeros are written on tracks 0 and 1 of the DEC magtape and the 9-track transport operates as a 7-track transport.

Load Function Register (LFGR)

Octal Code: 6706

Operation: Load the Function Register with the contents of the AC and clear the AC. The Function Register is the last register loaded because it contains the GO bit. This instruction determines what function the transport is to do.

SIZE CODE NUMBER REV  
A SP TMS-E-4 A

**ENGINEERING SPECIFICATION**

CONTINUATION SHEET

TITLE TMS-E SPECIFICATIONS FOR THE MAGNETIC TAPE CONTROL

Function Register Contents and Functions

Bit No. Function

0,1,2 Function Selection: These bits determine what function the transport is to perform.

Bit 0 Bit 1 Bit 2  
0 0 0

OFFLINE: The selected transport is taken OFFLINE and rewound to BOT. The MTF is set when the transport responds to this function and the controller can select and use another transport. The transport must be manually reset to the on-line state. The Word Count and Current Address Registers need not be loaded.

Bit 0 Bit 1 Bit 2  
0 0 1

REWIND: The transport rewinds at high speed (150 ips) to BOT and stops. The MTF is set when the transport responds to the Rewind Function. The controller can select and use another transport. The Word Count and Current Address Registers need not be loaded.

0 1 0

READ: Data is transferred from the tape to memory in the forward direction only. All registers must be loaded.

0 1 1

READ/COMPARE: Tape data is compared to data in core memory. All registers must be loaded. If there is a comparison error, CA incrementation ceases, and the R/C Error bit is set and tape motion continues to the end of the record. The CA register contains the address of the word that produced the error.

SIZE CODE NUMBER REV  
A SP TMS-E-4 A

**ENGINEERING SPECIFICATION**

CONTINUATION SHEET

TITLE TM8-E SPECIFICATIONS FOR THE MAGNETIC TAPE CONTROL

Bit 0	Bit 1	Bit 2	
1	0	0	WRITE: Data is written on the tape in the forward direction only. All registers must be loaded. The Write Function is controlled By WC OVERFLOW, which disables the Write and the transport writes the appropriate check characters to end the block.
1	0	1	WRITE END OF FILE (File Mark): The transport writes the File Mark which consists of a one word record. The CA and WC registers need not be loaded.
1	1	0	SPACE FORWARD: The transport moves forward at 45 ips the number of records specified by the WC register, or until a File Mark is read. If End of Tape is read, Space Forward stops at the first inter-record gap. The CA register need not be loaded for a Space Forward.
1	1	1	SPACE REVERSE: The transport moves in the reverse direction at 45 ips the number of blocks specified by the WC Register or until a File Mark or BOT marker is read. The CA Register need not be read during a Space Reverse.
Bit 3			EXTENDED GAP: When bit 3 is a one the transport writes an additional 3 inch gap between records.
4			ENABLE CHECK CHARACTER: When this bit is set (1) it allows the check characters to be read into the computer during a read function. When the Word Count Overflows, this bit allows two breaks during 9 track operation for the CRC and LRC. If a RECORD LENGTH INCORRECT error occurs, the check character is considered bad and is not used. This bit is used primarily for 9 track error correction.

SIZE A	CODE SP	NUMBER TM8-E-4	REV A
-----------	------------	-------------------	----------

**ENGINEERING SPECIFICATION**

CONTINUATION SHEET

TITLE TM8-E SPECIFICATIONS FOR THE MAGNETIC TAPE CONTROL

Bit 5	GO: This bit causes the controller to issue a SET command to the transport when the transport is capable of accepting it. The transport is capable of accepting it. The SET is not issued if the specified function is illegal.
6	EMA INC ENABLE: If this bit is not set (1) the TM8-E treats the extended memory the same way any other PDP8 Family data break option would, i.e., each 4K block is used in a wrap around mode. If this bit is set (1) the Extended Memory is treated as a continuous memory rather than 4K blocks. When the last location in one Field is reached, the EMA bits are incremented and the transfer continues in the next field, i.e.,: If a word is placed in Field 2, location 7777, the following word will be placed in Field 3, location 0000 if the EMA increment bit is set. If Bit 6 is not set the word is placed in Field 2, location 0000. In both modes of operation, the Current Address is set to one less than the first location to be accessed. In the EMA Increment mode the 120bit CA register with the EMA bits most significant. For example, to access field 2, location 20, load EMA=2 and CA=0017: to access field 2, location 0, load EMA=1 and CA=7777. If memory field 7 is selected, the EMA cannot increment, but wraps around in field 7 and an EMA 7 INCREMENT ERROR occurs.

SIZE A	CODE SP	NUMBER TM8-E-4	REV A
-----------	------------	-------------------	----------



**ENGINEERING SPECIFICATION**

CONTINUATION SHEET

TITLE TMS-E SPECIFICATIONS FOR THE MAGNETIC TAPE CONTROL

Load Data Buffer Register (LDBR)

Octal Code: 6707

Operation: Load the Data Buffer Register with the contents of the AC. Clear the AC and set MTF flag. This instruction is used for maintenance.

Read Word Count Register (RWCR)

Octal Code: 6711

Operation: Clear the AC and transfer the contents of the Word Count Register into the AC. This instruction is used primarily for maintenance, but it can also be used during error check routines.

Clear Transport (CLT)

Octal Code: 6712

Operation: Clear the transport master registers and clear all TMS-E registers and flags.

Read Current Address Register (RCAR)

Octal Code: 6713

Operation: Clear the AC and transfer the contents of the Current Address register to the AC. This instruction is used primarily for maintenance, but it may be used for error check routines.

SIZE A	CODE SP	NUMBER TMS-E-4	REV A
-----------	------------	-------------------	----------

**ENGINEERING SPECIFICATION**

CONTINUATION SHEET

TITLE TMS-E SPECIFICATIONS FOR THE MAGNETIC TAPE CONTROL

Read Main Status Register (RMSR)

Octal Code: 6714

Operation: Clear the AC and transfer the contents of the Main status register into the AC. The 12-bit status register contains the status of the transport and control logic (see Table 3-3 and Figure 3-4). The status register is read at any time (control Busy or Not Busy).

Table 3-3

Main Status Register Contents and Indications

Status Indication

Bit 0 ERROR: The ERROR flag interrupts the processor if bit 4 in the Command Register is set (1). An ILLEGAL FUNCTION, BAD TAPE, or SELECT ERROR sets the MTF flag immediately and stops Data Break operations. The following errors sets the ERROR flag after the MTF flag is set if they occur during any operation.

- a. BOT
- b. EOT
- c. READ/COMPARE ERROR
- d. Parity Error (VPE, CRCE, or LRCE)
- e. RECORD LENGTH INCORRECT
- f. File Mark (EOF)
- g. DATA LATE
- h. EMA 7 INCREMENT ERROR

1 Rewind Status (RWS): A one indicates the selected transport is rewinding.

2 Beginning of Tape (BOT): A one indicates the BOT reflective strip is sensed by the selected transport.

SIZE A	CODE SP	NUMBER TMS-E-4	REV A
-----------	------------	-------------------	----------

**ENGINEERING SPECIFICATION**

CONTINUATION SHEET

TITLE TM8-E SPECIFICATIONS FOR THE MAGNETIC TAPE CONTROL

Main Status Register Contents and Indications

Status Indication

- Bit 3 SELECT REMOTE: A one indicates the selected transport is not on-line.
- 4 PARITY ERROR: A one indicates a longitudinal parity error, vertical parity error, or CRC error has been detected.
- 5 File Mark (FMK): A one indicates the selected transport detected a File Mark during a Write FMK, Space, Read, or Read/Compare operation.
- 6 RECORD LENGTH INCORRECT: A one indicates that during a Read or Read/Compare operation, the record length was different from the contents of the WC Register. The Word Count Register is read to determine whether the record was long or short.
- 7 DATA REQUEST LATE: A one indicates the computer failed to service the break request before the next data transfer to or from the transport.
- 8 END OF TAPE (EOT): A one indicates the EOT reflective strip has been sensed by the selected transport.
- 9 FILE PROTECT: A one indicates the selected transport has a write lockout ring removed and no write functions are accepted.
- 10 R/C ERROR: A one indicates a comparison failure occurred during the Read/Compare function. The CA Register contains the address of the word which produced the error.

SIZE A	CODE SP	NUMBER TM8-E-4	REV A
-----------	------------	-------------------	----------

**ENGINEERING SPECIFICATION**

CONTINUATION SHEET

TITLE TM8-E SPECIFICATIONS FOR THE MAGNETIC TAPE CONTROL

- Bit 11 A one indicates one of the following ILLEGAL FUNCTIONS has been programmed.
  1. Execution of LCMR, LFGR, or LDBR while the control is busy.
  2. Specifying any density but 800 bpi for a 9 channel transport.
  3. A Space Reverse function when the transport is at BOT.
  4. Read, Read/Compare or Space Forward after a Write or Write End of File (WEOF) command on same transport.
  5. Changing to transports which are not ready (TUR is false). when preset is issued.
  6. Attempting to Rewind when tape is at BOT.
  7. Attempting to write when the transport is write protected.
- Read Command Register  
Octal Code: 6715  
Operation: Clear the AC and transfer the contents of the Command Register to the AC. The contents of the Command Register for this instruction are the same as that for the Load Command Register instruction.
- Read Function Register and Second Status Register (RFSR)  
Octal Code: 6716  
Operation: Clear the AC and transfer the contents of the Function Register and Second Status Register to the AC.

SIZE A	CODE SP	NUMBER TM8-E-4	REV A
-----------	------------	-------------------	----------

**ENGINEERING SPECIFICATION**



CONTINUATION SHEET

TITLE TMS-E SPECIFICATIONS FOR THE MAGNETIC TAPE CONTROL

Second Status Register Contents and Functions

Bit No.	Function
7	NOT USED
8	EMA 7 INC ERROR: EMA 7 INC ERROR occurs if you attempt to increment the EMA from Field 7 to Field 0. The data wraps around in Field 7.
9	VERTICAL PARITY ERROR (VPE): A one indicates a VPE Error has been detected. This bit is set only on the character that is bad and cleared by the next good character.
10	CRC ERROR (CRCE): A one indicates a CRC Error has been detected.
11	LONGITUDINAL PARITY ERROR (LRCE): A one indicates a longitudinal parity error has been detected.

Read Data Buffer Register (RDBR)  
 Octal Code: 6717  
 Operation: Clear the AC and transfer the contents of the Data Buffer Register to the AC. This instruction may be used in an error check routine to read the contents of the LRC Register.

SIZE A	CODE SP	NUMBER TMS-E-4	REV A
-----------	------------	-------------------	----------

**ENGINEERING SPECIFICATION**



CONTINUATION SHEET

TITLE TMS-E SPECIFICATIONS FOR THE MAGNETIC TAPE CONTROL

Skip If ERROR Flag Is Set (SKEF)

Octal Code: 6721

Operation: Skip the next instruction if the ERROR flag is set.

Skip Control Not Busy (SKCB)

Octal Code: 6722

Operation: Skip the next instruction if the control is not busy. Control is busy when the transport is in a GO condition and becomes not busy when MTF is set at the End of Job (data transfer completed).

Skip Job Done (SKJD)

Octal Code: 6723

Operation:1 Skip the next instruction if the MTF is set under following conditions.

- a. When the Job Done (MTF) is set at LRC's time of a Read, Read/Compare, Write, or Write File Mark operation.
- b. At the LRC's time following EOT, FMK, or WCOV during spare operations.
- c. MTF is set by OFFLINE Function, SELECT ERROR.
- d. MTF is set by a LDBR (Load Data Buffer Register) instruction and WCOV.
- e. When Rewinding Status & Rewind Function.

Skip if Tape Unit Ready (SKTR)

Octal Code: 6724

Operation: Skip the next instruction if the Tape Unit is Ready (TUR is true).

SIZE A	CODE SP	NUMBER TMS-E-4	REV A
-----------	------------	-------------------	----------

TITLE TM8-E SPECIFICATIONS FOR THE MAGNETIC TAPE CONTROL

Clear All Register and Flag (CLF)

Octal Code: 6725

Operation: Clear all TM8-E registers and flags if TUR is true. If TUR is false clear MTF, ERROR flag and Status Registers.

Check Data Late Error (CKDL)

Octal Code: 6727

Operation: Force a DATA LATE error condition during a data transfer. This instruction is used only for maintenance.

Set Break Request (SBRM)

Octal Code: 6727

Operation: Set BRK RQST for one Data Break. This instruction is used for maintenance only.

## 6. Power Failure

6.1 Computer power failure will cause the TU10's to shut down through the use of a power control. Restart of the transport will be manual. Refer to Par. 3.2.3 TU10 Maintenance Manual, in addition to Par. 3.2.3:

When it is desired to continue operation the tape must be returned to a reference point such as BOT.

## 6.2 Transport Power Failure

Refer to Par. 3.2.3 and 3.2.4 TU10 Maintenance Manual, plus the addition in Par. 6.1 of this document.

SIZE  
A

CODE  
SP

NUMBER  
TM8-E-4

REV  
A

DIGITAL EQUIPMENT CORPORATION MAYNARD, MASSACHUSETTS			LEGEND		QUANTITY/VARIATION												
MADE BY J. CAHILL DATE 10/27/72		CHECKED DATE	SECTION 1	PA PAPER TAPE ASCII PB PAPER TAPE BINARY PM PAPER TAPE READ-IN-MODE	TM8-E							KIT CHECK	BY	DATE	INSTALLATION CHECK	BY	DATE
ENG <i>C. S. L.</i> DATE 10-10-72		PROD <i>D. Vanev</i> DATE 11-10-72	ISSUED SECT. 1														
ITEM NO.	DWG NO. / PART NO.	DESCRIPTION															
1	MAINDEC-08-DHTMA-A-D	TM8-E CONTROL TEST PART I		1													
2	MAINDEC-08-DHTMA-A-PB	TM8-E CONTROL TEST PART I		1													
3	MAINDEC-08-DHTMB-A-D	TM8-E CONTROL TEST PART II		1													
4	MAINDEC-08-DHTMB-A-PB	TM8-E CONTROL TEST PART II		1													
5	MAINDEC-08-DHTMC-A-D	DRIVE FUNCTION TIMER		1													
6	MAINDEC-08-DHTMC-A-PB	DRIVE FUNCTION TIMER		1													
7	MAINDEC-08-DTMD-A-D	TM8-E DATA RELIABILITY TEST 9 TRACK		1													
8	MAINDEC-08-DTMD-A-PB	TM8-E DATA RELIABILITY TEST 9 TRACK		1													
9	MAINDEC-08-DTME-A-D	TM8-E DATA RELIABILITY TEST 7 TRACK		1													
10	MAINDEC-08-DTME-A-PB	TM8-E DATA RELIABILITY TEST 7 TRACK		1													
11	MAINDEC-08-DHTMF-B-D	TM8-E RANDOM EXERCISER		1													
12	MAINDEC-08-DHTMF-B-PB	TM8-E RANDOM EXERCISER		1													
TITLE TM8-E SOFTWARE LIST				ASSY. NO. <i>//</i>	SIZE CODE A SL	NUMBER TM8-E-7			REV. A	ECO NO TM8E-00002			DIST.				
				SHEET 1 OF 1													

DEC FORM NO.  
DRA 120



This drawing and specifications, herein, are the property of Digital Equipment Corporation and shall not be reproduced or copied or used in whole or in part as the basis for the manufacture or sale of items without written permission.

<b>DIGITAL EQUIPMENT CORPORATION</b>						
MAYNARD, MASSACHUSETTS						
						DATE 03/13/73
TITLE TM8E ACCEPTANCE PROCEDURE						
REVISIONS						
REV	DESCRIPTION	CHG NO	ORIG	DATE	APPD BY	DATE
A	UPDATE PER ECO	TM8E-00002	LORD	11/73	<i>Carl Cline</i>	2/74

ENG	APPD <i>Carl Cline</i>	SIZE <b>A</b>	CODE SP	NUMBER TM8-E-9	REV <b>A</b>
-----	------------------------	------------------	------------	-------------------	-----------------

<b>ENGINEERING SPECIFICATION</b>		<b>000001</b>	CONTINUATION SHEET
TITLE	TM8E ACCEPTANCE PROCEDURE		
1.0	SCOPE		
	To define the criteria necessary to accept for shipment of the TM8E magtape control.		
2.0	TEST SOFTWARE		
	Control Test Part 1	MAINDEC-08-DHTMA	
	Control Test Part 2	MAINDEC-08-DHTMB	
	Drive Function Timer	MAINDEC-08-DHTMC	
	Data Reliability 9 CH	MAINDEC-08-DHTMD	
	Data Reliability 7 CH	MAINDEC-08-DHTME	
	Random Exerciser	MAINDEC-08-DHTMF	
	DEC/X8 Module TM8EMT	MAINDEC-X8-DHTMA	
3.0	TEST HARDWARE		
	3.1 Computer		
	PDP8E,M,F with a standard programmer's console and at least 4K of read/write memory and a teletype.		
	3.2 Tape Unit		
	TU10 Master		
4.0	PROCEDURE		
	4.1 Install TM8E (M8321, M8322, M8323, M8327) into omnibus, refer to PDP8E Maintenance Manual, Vol. 1 for module priority.		
	4.2 Install BC08L cable between control and TU10 Master, BC08L to be correct length for system not to exceed 15 feet. Also install M989 terminator in Slot A06 or A07 of TU10 Master.		
	4.3 Install six (6) H851 top connectors.		
	4.4 Run Control Test Part 1, MAINDEC-08-DHTMA for 2 complete long passes without any errors.		
	4.5 Run Control Test Part 2, MAINDEC-08-DHTMB		
	4.5.1 Run each transport selected to unit zero for one complete long pass without any errors. (Tests 15 through 30. This includes manual intervention.)		

		SIZE <b>A</b>	CODE SP	NUMBER TM8-E-9	REV <b>A</b>
--	--	------------------	------------	-------------------	-----------------

**ENGINEERING SPECIFICATION**

digital

CONTINUATION SHEET

TITLE TM8E ACCEPTANCE PROCEDURE

4.0 PROCEDURE (Continued)

4.5 Run Control Test Part 2, MAINDEC-08-DHTMB (Con't)

4.5.2 Run each transport one quick verify pass for each unit select position. (Unit 0-7). Tests 15 through 27, Manual intervention need not be run.

4.6 Run Drive Function Timer through two complete passes insuring no drastic changes in timing, these printouts to be shipped with transports. See Note 4.

4.7 Unit Compatibility

Using previously generated test tape run Data Reliability 7 or 9 depending upon type of unit being tested to insure compatibility. Use Test 9, Pattern 5, odd parity, max to min and set switch 4, no non-recoverable read errors are allowed and no more than two recoverable read errors are allowed. Repeat this for each unit in the system.

Test	Pattern	Parity	Density	RLS	WMO	RMO
9	5	1	800	3	1	1

5.0 RUN DATA RELIABILITY TEST

Use the following test on all 7 or 9 channel units respectively. See Notes 1 and 2.

7 CH Unit

Test	Pattern	Parity	Density	RLS	WMO	RMO
4	6	1	800	2	1	1
5	7	1	556	3	2	2
5	5	1	200	1	0	0

9 CH Unit

Test	Pattern	Parity	Density	RLS	WMO	RMO
4	6	1	800	2	1	1
5	7	1	800	3	2	2
5	5	1	800	1	0	0

6.0 Run Random Exerciser for 2 hours per unit. See Note 1.

SIZE A	CODE SP	NUMBER TM8-E-9	REV A
-----------	------------	-------------------	----------

**ENGINEERING SPECIFICATION**

digital

CONTINUATION SHEET

TITLE TM8E ACCEPTANCE PROCEDURE

7.0 SYSTEM EXERCISER - DEC/X8

7.1 Run DEC/X8 using TM8EMT module for the prescribed time to accept a system with a Data Break. See Note 3. Refer to Engineering Specification "DEC/X8 System Checkout and Acceptance Procedure for 8 Family Systems" for exact time to be run.

8.0 SHIPPING SOFTWARE

Manual: TM8E Maintenance Manual

Print Set: TM8-E-0

Programs: Control Test Part 1 - MAINDEC-08-DHTMA  
Control Test Part 2 - MAINDEC-08-DHTMB  
Drive Function Timer- MAINDEC-08-DHTMC  
Data Reliability 9CH- MAINDEC-08-DHTMD  
Data Reliability 7CH- MAINDEC-08-DHTME  
Random Exerciser - MAINDEC-08-DHTMF

9.0 SHIPPING HARDWARE

9.1 (2) BC08L cables, length as required not to exceed 15 feet.

9.2 (1) M8321 Output Control

9.3 (1) M8332 Control Board

9.4 (1) M8323 Input Control

9.5 (1) M8327 Register Board

9.6 (1) M989 Terminator Board

9.7 (6) H851 Top Connector

SIZE A	CODE SP	NUMBER TM8-E-9	REV A
-----------	------------	-------------------	----------



**ENGINEERING SPECIFICATION**

CONTINUATION SHEET

TITLE TM8E ACCEPTANCE PROCEDURE

- NOTE 1:
- a) Tape must be of known condition and unit must be clean.
  - b) No more than 7 WRITE status errors per pass of tape. A permanent WRITE error (written with XIRG four times and still bad) means that the tape is physically bad and must be replaced. See Note 1A.
  - c) No more than 2 recoverable read errors in a pass of tape.
  - d) No non-recoverable read errors.
  - e) No mechanical or control failures.
  - f) No DATA errors without parity and error flag.

NOTE 2: DATA RELIABILITY

- a) READ Errors are the total number of READ errors including errors on rereads.
- b) NON-Recoverable Error is encountered when an attempt to read a record fails after 2 rereads.
- c) Data Errors are the total number of Read/Compare errors not including rereads.
- d) Data No Status is the total of data errors not accompanied by any error status flags. This condition should be regarded as non-recoverable.

NOTE 3: ERROR ECPLANATION DEC/X8

- a) Total number of write parity errors not to exceed seven per pass of tape.
- b) Total number of read parity errors not to exceed four per pass of tape.
- c) No fatal errors are allowed.
- d) To determine if the TM8E is acceptable, refer to the following information to decipher the print-outs from DEC/X8.

Following is a chart of the possible error conditions that can exist. The type of error is listed to the right. (WRITE, READ and FATAL) and an explanation of each condition is following.

SIZE	CODE	NUMBER	REV
A	SP	TM8-E-9	A

**ENGINEERING SPECIFICATION**

CONTINUATION SHEET

TITLE TM8E ACCEPTANCE PROCEDURE

ERROR CONDITIONS	CODE 4000 WRITE PARITY ERRORS	CODE 3000 READ/COMPARE PARITY ERRORS	CODE 2000 READ PARITY ERRORS	CODE 2000 READ DATA ERROR	EOT	MULTI	TYPE
1	0	0	0	0	1	1	OK
2	1	X	X	X	0	1	WRITE
3	0	X	X	0	0	X+X	READ
4	0	X	1	1	0	TALLY	READ
5	0	X	0	1	0	1	FATAL

X = May or may not be true      0 = A false Condition  
1 = A true condition

MULTI = The number of errors (READ, WRITE, or Fatal) per condition to be added to the total allowable errors per pass of tape.

SIZE	CODE	NUMBER	REV
A	SP	TM8-E-9	A

**ENGINEERING SPECIFICATION**

CONTINUATION SHEET

TITLE TM8E ACCEPTANCE PROCEDURE

- Condition One: The End-of-Tape (EOT) is detected generally during a WRITE operation; however, it may occur during either Read Compare or Read Operations. The status is typed out at this time indicating the magtape has reached the end of tape. The transport will then be rewound to BOT and continue until an error or EOT is encountered. This condition is not an error, it is only an indication of the number of passes of tape.
- Condition Two: A WRITE status error may occur seven times per pass of tape. Condition two indicates a write status error has occurred. The SA and SJ register must be examined to guarantee only a parity error was encountered. A Read/Compare and/or a Read Status Error may follow the WRITE status printout. If the CNTR number and the SL number are the same as the previous WRITE status printouts, disregard the READ error and Read/Compare and count this condition as ONE WRITE PARITY ERROR. If, however, an error status bit other than a parity or Read/Compare error is encountered, this condition should be regarded as FATAL.
- Condition Three: Per pass of tape only four read errors are allowed.
- Condition three will involve a parity error on either read or read/compare operation; this condition should be counted as one READ ERROR. However, if both Read and Read/Compare operations encountered parity errors and the CNTR number and SL number for each are the same, this condition should be counted as two READ errors. In both of the preceding examples, if any error status bit other than a parity or Read/Compare error is set, then a FATAL error was encountered.
- Condition Four: Condition 4 is the same as Condition 3 with the exception that the TALLY will equal the number of READ errors for both Read/Compare and READ operations.
- Condition Five: Condition 5 involves a DATA error without any parity or error status bits set. This type error should be considered Fatal.

SIZE A	CODE SP	NUMBER TM8-E-9	REV A
-----------	------------	-------------------	----------

**ENGINEERING SPECIFICATION**

CONTINUATION SHEET

TITLE TM8E ACCEPTANCE PROCEDURE

NOTE 4: TIME LIMITS SPECIFICATION

The table below lists the time limits in the same format as they are printed on the TTY. Times listed under Unit 0 are 9 track times, and those under Unit 1 are 7 track times. All times are in milliseconds.

FUNCTION	(9 Track) +/-		(7 Track) +/-	
	Unit 0		Unit 1	
800 BPI	Unit 0		Unit 1	
WR FM BOT Delay	185	15	185	15
WRITE SHUTDOWN	2.7	0.5	2.7	0.5
WRITE START	8.9	1.0	12.6	1.0
WR NONSTOP GAP	11.5	2.0	14.5	2.0
BKSP SHOWN+SDWN	15	5	19	5
READ SHUTDOWN	1.8	0.5	1.8	0.5
WRITE XRIG	95	10	95	10
LAST CHR TC CUR	0.3	0.1	0.3	0.1
RD FM BOT DELAY	185	15	185	15
SPCE SHDWN+SDWN	14	5	14	5
WRITE EOF	100	10	105	10
ER TO EF SP TME	100	10	105	10
WR TO ERASE HEAD	12	5	12	5
1 INCH DATA TIME	22	1	22	1
GAP 1				
GAP 2				
GAP 3				
GAP 4				
GAP 5				
GAP 6				
GAP 7				
GAP 8				
GAPS: 8>7>6>5>4>1; 1-2<1,7; 2>3				
556 BPI	Unit 1	+/- (7 Track)		
WR FM BOT DELAY	185	15		
WRITE SHUTDOWN	2.7	0.5		
LAST CHR TO CUR	0.35	0.1		
BKSP SHDWN+SDWN	19	5		
READ SHUTDOWN	1.8	0.5		
1 INCH DATA TIME	22	1		
200 BPI	Unit 1	+/- (7 Track)		
WR FM BOT DELAY	185	15		
WRITE SHUTDOWN	2.7	0.5		
LAST CHR TO CUR	1.05	0.2		
BKSP SHDWN+SDWN	19	5.0		
READ SHUTDOWN	1.8	0.5		
1 INCH DATA TIME	22	1		

SIZE A	CODE SP	NUMBER TM8-E-9	REV A
-----------	------------	-------------------	----------