

digital

R X8

Engineering Drawings

Digital Equipment Corporation

The material herein is for information purposes only and is subject to change without notice. Digital Equipment Corporation assumes no responsibility for any errors which may appear herein.

These drawings and specifications herein are the property of Digital Equipment Corporation and shall not be reproduced or copied or used in whole or in part as the basis for the manufacture or sale of items without written permission.
Copyright © 1975, Digital Equipment Corporation

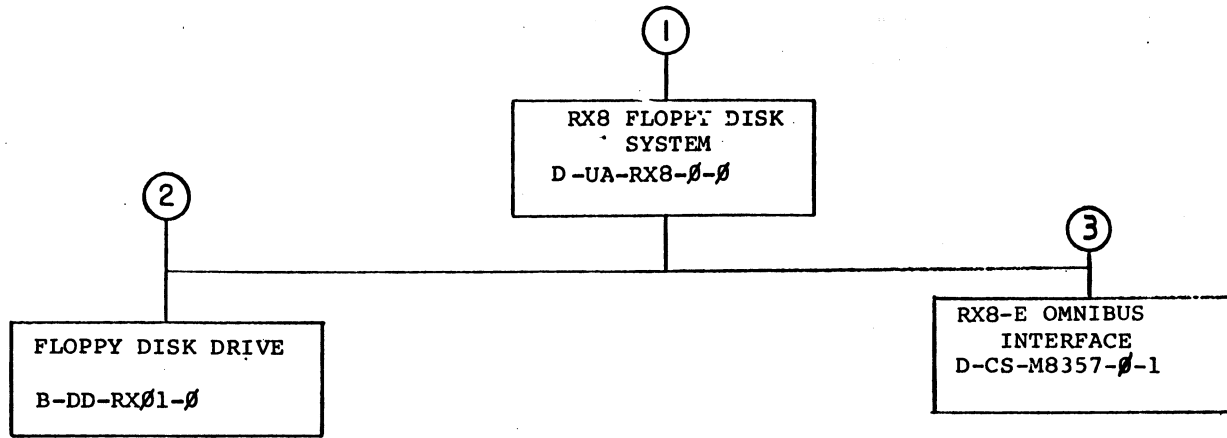

| TITLE | SHEET 2 OF 3 | SIZE | CODE | NUMBER | REV |
|------------------------|--------------|------|------|--------|-----|
| RX8 FLOPPY DISK SYSTEM | | B | DD | RX8-Ø | A |

| CUSTOMER PRINT SET | | ELECTRICAL | | | | | CUSTOMER PRINT SET | | MECHANICAL | | | | | | |
|--------------------|----------|------------|----------------|-----|-----------|--------------------------------|----------------------|---|------------|----------|------------------|-----|-----------|---------------------------------|----------------------|
| 1 | MFG. SET | FIND NO. | DRAWING NO. | REV | NO OF SHT | DESCRIPTION | OPTION NO./FILE DATE | 1 | MFG. SET | FIND NO. | DRAWING NO. | REV | NO OF SHT | DESCRIPTION | OPTION NO./FILE DATE |
| X | | 1 | B-DD-RX8-Ø | # | 3 | DRAWING DIRECTORY, RX8 | | X | | 1 | D-UA-RX8-Ø-Ø | # | 1 | RX8 FLOPPY DISK SYSTEM | |
| | | | A-SP-RX8-Ø-1 | | | CHECKOUT PROCEDURE | | | | | A-PL-RX8-Ø-Ø | # | 1 | RX8 FLOPPY DISK SYSTEM P.I. | |
| X | | | A-PL-RX8-Ø-3 | # | 1 | SHIPPING LIST | | | | | A-PI-3700185-0-0 | | 2 | PACKAGING INSTRUCTIONS | |
| | | | A-SP-RX8-Ø-4 | # | 12 | ACCEPTANCE PROCEDURE | | | | | A-PI-3700193-0-0 | | | CUSTOMER PACKAGING INSTRUCTIONS | |
| | | | A SP-RX8-Ø-5 | #: | 11 | RX8E ENGINEERING SPECIFICATION | | | | | | | | | |
| X | | 3 | D-CS-M8357-Ø-1 | # | 3 | RX8-E OMNIBUS INTERFACE | | | | 2 | B-DD-RXØ1-Ø | # | 3 | FLOPPY DISK DRIVE | |
| | | | A-SP-M8357-Ø-7 | | 3 | ACCEPTANCE TEST PROCEDURE | | | | | | | | | |

CUSTOMER PRINT SET CODES
X = PRINT OF DOCUMENT INCLUDED IN PRINT SET
C = INCLUDES ALL PRINTS INDICATED ON DOCUMENT
S = CONFIDENTIAL AUTHORIZED SIGNATURE REQUIRED

TITLE
RX8 FLOPPY DISK SYSTEM

SIZE CODE
B DD

NUMBER
RX8-Ø

REV
A

SHEET 3 OF 3

"THIS DRAWING AND SPECIFICATIONS HEREIN ARE THE PROPERTY OF DIGITAL EQUIPMENT CORPORATION AND SHALL NOT BE REPRODUCED OR COPIED OR USED IN WHOLE OR IN PART AS THE BASIS FOR THE MANUFACTURE OR SALE OF ITEMS WITHOUT WRITTEN PERMISSION. COPYRIGHT © 1974, DIGITAL EQUIPMENT CORPORATION"

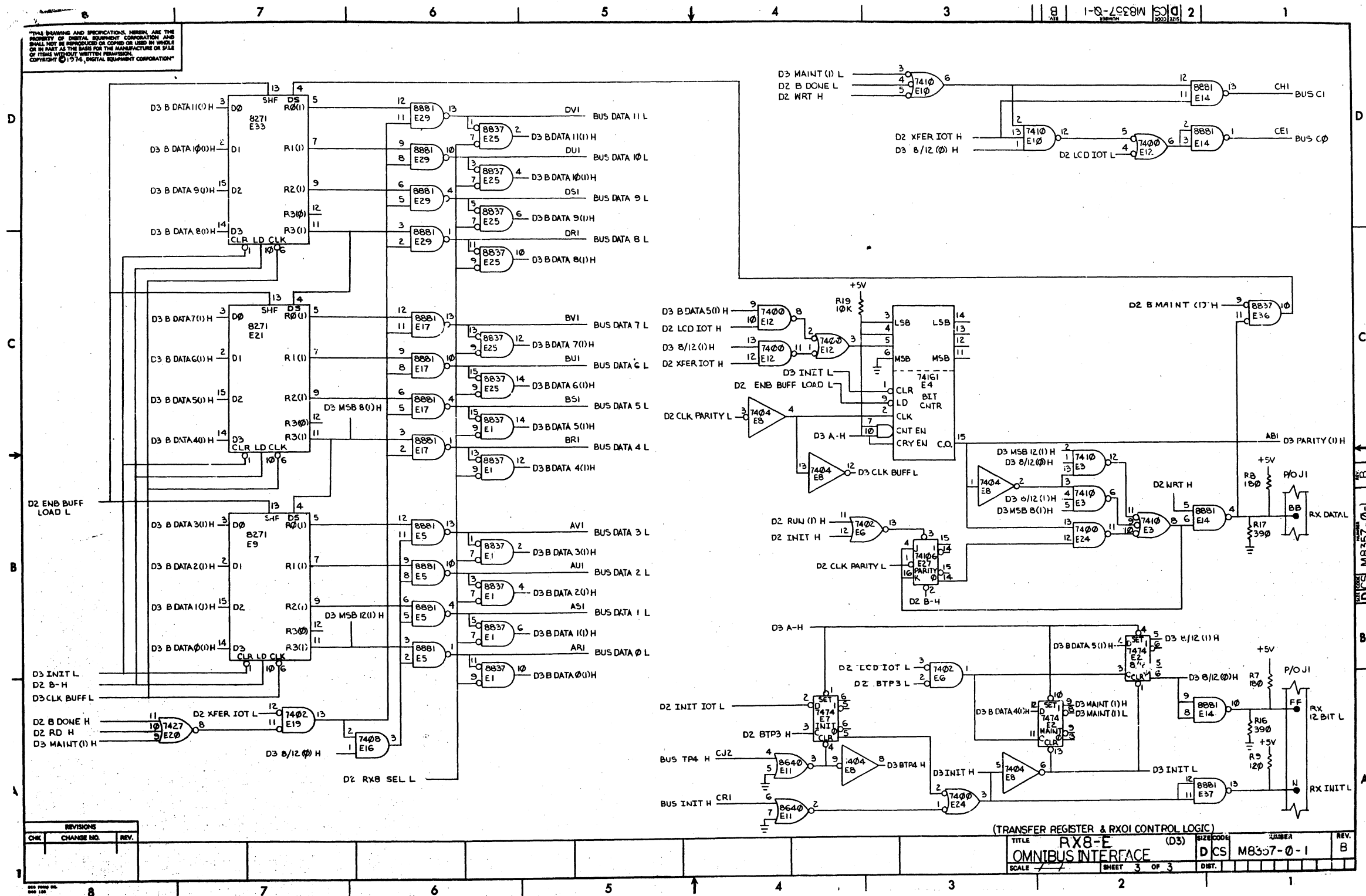

| REVISIONS | | |
|-----------|------------|------|
| CHK | CHANGE NO. | REV. |
| | | |

| | | | | | | | |
|-------------------|--------------|------------|------|-----------|-----------|----------|---|
| TITLE | | RX8-E (D3) | | SIZE CODE | 1000 | REVISION | B |
| OMNIBUS INTERFACE | | D3 | | DCS | M8357-0-1 | REV. B | |
| SCALE | SHEET 3 OF 3 | | DST. | | | | |

