

igital

hardware

**PDP-8 family
configuration guide**



PDP8

more than 30,000 installed worldwide

**PDP-8 family
configuration guide**

EK-0PDP8-SP-001

1st Edition, April 1978

Copyright © 1978 by Digital Equipment Corporation

The material in this manual is for informational purposes and is subject to change without notice.

Digital Equipment Corporation assumes no responsibility for any errors which may appear in this manual.

Printed in U.S.A.

This document was set on DIGITAL'S DECset-8000 computerized typesetting system.

The following are trademarks of Digital Equipment Corporation, Maynard, Massachusetts:

DEC	DECtape	PDP
DECCOMM	DECUS	RSTS
DECsystem-10	DIGITAL	TYPESET-8
DECSYSTEM-20	MASSBUS	TYPESET-11
		UNIBUS

CONTENTS

	Page
INTRODUCTION	
CHAPTER 1 GENERAL	
1.1	POWER SUPPLY CONVERSION.....1-1
1.2	SPECIFICATIONS.....1-1
CHAPTER 2 OPTIONS	
2.1	INTRODUCTION.....2-1
2.2	MODULE PLACEMENT RULES.....2-5
2.3	OPTION CONFIGURATION WORKSHEETS.....2-6
CHAPTER 3 SYSTEM EXPANSION	
3.1	INTRODUCTION.....3-1

FIGURES

Figure No.	Title	Page
1-1	Power Supply Conversion Chart.....	1-2
2-1	PDP-8/A Computer Designations.....	2-5
3-1	PDP-8 Family Expansion Possibilities.....	3-1
3-2	PDP-8/E (1-Omnibus) Expansion.....	3-2
3-3	PDP-8/M Expansion.....	3-3
3-4	PDP-8/E (2-Omnibus) Expansion.....	3-4
3-5	8A600 Expansion.....	3-5
3-6	8A620 or 8A625 (+ H9300) Expansion.....	3-6
3-7	8A620 or 8A625 (+ BA8-C) Expansion.....	3-7

TABLE

Table No.	Title	Page
2-1	PDP-8 Module Placement Chart.....	2-2

INTRODUCTION

The *PDP-8 Family Configuration Guide* is intended to aid the PDP-8 user in both planning the composition of a PDP-8 system and organizing the system components in the most efficient way. The manual specifies power and environmental requirements, dimensions, and weights, states rules concerning the placement of option modules in the PDP-8 Omnibus, and provides charts and worksheets that enable the user to visualize his system concept.

The manual is divided into three chapters. Chapter 1 contains a power supply conversion chart and lists some specifications that are common to all PDP-8 computers; before considering the details of system organization, the user should ensure that these specifications can be satisfied. Chapter 2 lists the options that can be used with PDP-8 computers, indicating the Omnibus slot assignments and power requirements for each option module; included are worksheets that permit the user to plan a configuration of options on the Omnibus for each computer type. Chapter 3 provides configuration worksheets for PDP-8 systems comprising more than one chassis.

CHAPTER 1 GENERAL

1.1 POWER SUPPLY CONVERSION

Figure 1-1 shows the parts needed to convert the standard voltage and frequency combinations (115 V, 60 Hz and 230 V, 50 Hz) to other combinations. When changing from a standard to a non-standard combination, both a line cord set and a power transformer or a line cord set alone must be replaced. For example, when changing an H9300 chassis from the standard 115 V, 60 Hz to the non-standard 115 V, 50 Hz, both the line cord set and the power transformer must be replaced; thus, the 115 V, 50 Hz H9300 chassis will have line cord set 70-10915-05 and transformer 70-10935-02. The line cord sets and the transformers can be ordered from DIGITAL's Spare Parts product line.

1.2 SPECIFICATIONS

Temperature Range*

Recommended	15° to 32° C (59° to 90° F)
Maximum	5° to 50° C (41° to 122° F)

Relative Humidity Range

Recommended	30 to 80% (non-condensing) with maximum wet bulb temperature of 25° C (77° F) and minimum dew point of 2° C (36° F)
Maximum	10 to 90% (non-condensing) with maximum wet bulb temperature of 32° C (90° F) and minimum dew point of 2° C (36° F)

Required Line Voltage and Frequency

90–132 Vac, 49–51 Hz/59–61 Hz, single-phase or
180–264 Vac, 49–51 Hz/59–61 Hz, single-phase

Line Plug Type

NEMA type 5-15P (125 V) or 6-15P (250 V) (2-pole, 3-wire, grounding, non-locking plug)

*Temperature range applies to each unit, alone. The temperature within a cabinet might satisfy the specified requirements, while the temperature within a particular unit exceeds the limit.

**12-SLOT CHASSIS, H9300
(8A100, 8A205, 8A400, 8A405, 8A600, FPP8-E)**

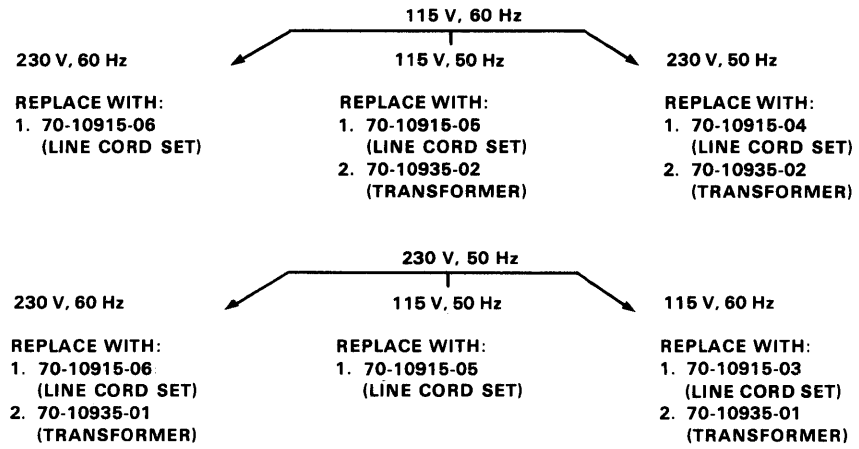

**20-SLOT CHASSIS, BA8-C
(8A420, 8A425, 8A620, 8A625)**

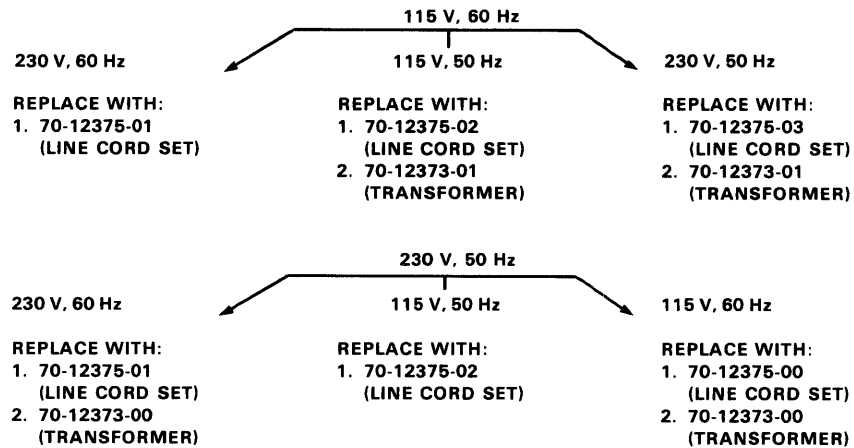

MA-1396

Figure 1-1 Power Supply Conversion Chart

CHAPTER 2 OPTIONS

2.1 INTRODUCTION

Table 2-1 lists the options available for use with the PDP-8 computers and includes both the Omnibus slot assignment and power requirement for each option. All the quad modules listed in Table 2-1, except the MS8-A memories, will function electronically in any slot of the PDP-8/E or PDP-8/M. The assignments specified in the table reflect the practicalities of system composition. For example, even though an XY8-E control will work in any slot of a PDP-8/E or PDP-8/M, it can never be placed in slot 20 because slot 20 will always be filled with either an M8320 module or an M935 interconnecting card.

The slots assigned to modules in the PDP-8/A computer are slots in which a module will function electronically. These assignments are quite general and can be made specific only when the composition of the system has been determined. For example, a DR8-EA (digital I/O interface) will operate correctly when inserted in slot 2 of an 8A400 computer. (This implies that quad modules already occupy slots 3 through 12; refer to rule 1, Paragraph 2.2.) Such a situation arises only when the computer is equipped with semiconductor memory, and then only if the memory capacity is 4K or less. (If core memory is used, the first memory unit would be inserted in slots 4 and 5; hence, the DR8-EA could not be in slots 2 or 3.) If more than 4K of semiconductor memory is present, a KM8-A option, which works only in slot 2 or slot 3, might be included in the system. Since the KM8-A is a hex module, while the DR8-EA is a quad module, the KM8-A would go in slot 2 and the DR8-EA in slot 3. To continue the example, if the computer were equipped with core memory, the DR8-EA could be placed no higher than slot 6 of the Omnibus. (This placement would occur if only one memory unit were present and slots 7 through 12 were filled with quad modules.)

As Table 2-1 shows, there is a variety of PDP-8/A computers. Each PDP-8/A computer designation describes the composition of the computer, i.e., the type of CPU, the type of chassis, and the type of memory assigned to that computer. Figure 2-1 shows the breakdown of the PDP-8/A designations.

The 8A100, having a KK8-A CPU and a 12-slot chassis and using a semiconductor memory, does not conform to this breakdown. The 8A205 differs from the 8A405 in that the 8A205 power supply has a G8016 regulator that permits battery backup of the power supply voltages.

Some general restrictions and requirements concerning module placement can be stated. These rules (Paragraph 2.2) apply, as stated, to unexpanded systems only. With some qualifications, certain rules are applicable to expanded systems; these rules are defined in Paragraph 3.2.

Table 2-1 PDP-8 Module Placement Chart

Option	Description	Board Size	Number of Slots Used	Assigned Slot Number in Basic Chassis								Current Requirements		
				PDP-8/E		PDP-8/M	PDP-8/A					+5 V	+15 V	-15 V
				1 Omnibus	2 Omnibuses		8A100	8A205 8A400 8A405	8A420 8A425	8A600	8A620 8A625			
AD8-A, B	A/D Converter	Quad	1	5-19	5-19, 22-39	5-19	4-10	4-12	4-20	4-12	4-20	-	-	-
CM8-F	Card Reader	Quad	1	5-19	5-19, 22-39	5-19	4-10	4-12	4-20	4-12	4-20	0.55 A	-	-
CR8-F	Controls	Quad	1	5-19	5-19, 22-39	5-19	4-10	4-12	4-20	4-12	4-20	0.55 A	-	-
DB8-EA	Interprocessor Buffer	Quad	1	5-19	5-19, 22-39	5-19	2-10	2-12	2-20	2-12	2-20	0.80 A	-	0.03 A
DKC8-A	I/O Option Board	Hex	1	-	-	-	2-3	2-3	2-3	2-3	2-3	2.0 A	0.06 A	0.1 A
DK8-EA	Line Frequency Real-Time Clock Option	Quad	1	5-19	5-19, 22-39	5-19	-	-	-	-	-	0.34 A	-	-
DK8-EC	Crystal-Controlled Real-Time Clock Option	Quad	1	5-19	5-19, 22-39	5-19	2-10	2-12	2-20	2-12	2-20	0.34 A	-	-
DK8-EP	Programmable Real-Time Clock Option	Quad	2	5-19	5-19, 22-39	5-19	2-10	2-12	2-20	2-12	2-20	1.43 A	-	0.07 A
DP8-EA, EB	Modem Interface	Quad	2	5-19	5-19, 22-39	5-19	2-10	2-12	2-20	2-12	2-20	1.80 A	0.05 A	0.11 A
DR8-EA	Digital I/O Interface	Quad	1	5-19	5-19, 22-39	5-19	2-10	2-12	2-20	2-12	2-20	2.25 A	-	-
FPP8-A	Floating-Point Processor	Hex	2	-	-	-	4-10	4-12	4-20	4-12	4-20	8.8 A	-	-
KA8-E	Positive I/O Bus Interface	Quad	1	5-19	5-19, 22-39	5-19	4-10	4-12	4-20	4-12	4-20	1.40 A	-	-
KC8-AA, AB	Programmer's Console	PDP-8/A Panel Mount	0	-	-	-	-	-	-	-	-	2.5 A	-	-
KC8-EA	Programmer's Console	Quad	1	1	1	1	-	-	-	-	-	2.0 A	-	-
KD8-E	Data Break Interface	Quad	1	5-19	5-19, 22-39	5-19	4-10	4-12	4-20	4-12	4-20	1.2 A	-	-
KE8-E	EAE IR (M8340)	Quad	1	3	3	3	-	-	-	11	19	1.60 A	-	-
	EAE Reg (M8341)	Quad	1	4	4	4	-	-	-	10	18			
KG8-EA	Redundancy Check Option	Quad	1	5-19	5-19, 22-39	5-19	4-10	4-12	4-20	4-12	4-20	0.94 A	-	-
KK8-A	PDP-8/A CPU	Hex	1	-	-	-	1	1	1	-	-	5.0 A	-	0.04 A
KK8-E ¹ (PDP-8/E CPU)	Major Reg (M8300)	Quad	1	4 ²	4 ²	4 ²	-	-	-	10 ³	18 ³	1.7 A	-	-
	Major Reg Control (M8310)	Quad	1	3 ²	3 ²	3 ²	-	-	-	11 ³	19 ³	0.60 A	-	-
	Timing Gen (M8330)	Quad	1	2	2	2	-	-	-	12	20	1.20 A	-	-
	Bus Loads (M8320)	Quad	1	20	40	20	-	-	-	1	1	1.0 A	1.0 A	0.53 A
KL8-A	Multiple Serial Line Unit	Hex	1	-	-	-	4-10	4-12	4-20	4-12	4-20	2.5 A	0.09 A	0.425 A
KL8-JA	Asynchronous Data Control	Quad	1	5-19	5-19, 22-39	5-19	2-10	2-12	2-20	2-12	2-20	1.1 A	0.05 A	0.10 A
KL8-M	Modem Control	Quad	1	5-19	5-19, 22-39	5-19	2-10	2-12	2-20	2-12	2-20	0.40 A	0.04 A	0.04 A
KM8-A	Memory Extension and Time-Share, Power-Fail/ Auto-Restart, and Bootstrap	Hex	1	-	-	-	2-3	2-3	2-3	2-3	2-3	2.0 A	-	-

Table 2-1 PDP-8 Module Placement Chart (Cont)

Option	Description	Board Size	Number of Slots Used	Assigned Slot Number in Basic Chassis								Current Requirements		
				PDP-8/E		PDP-8/M	PDP-8/A					+5 V	+15 V	-15 V
				1 Omnibus	2 Omnibuses		8A100	8A205 8A400 8A405	8A420 8A425	8A600	8A620 8A625			
KM8-E	Memory Extension and Time-Share Control	Quad	1	5 ²	5 ²	5 ²	4-10	4-12	4-20	4-12	4-20	1.0 A	-	-
KP8-E	Power-Fail/Auto Restart Option	Quad	1	5-19	5-19, 22-39	5-19	-	-	-	-	-	0.28 A	-	0.04 A
KT8-A	128K Memory Management	Hex	1	-	-	-	-	4-8 ⁵	4-11	4-8 ⁵	4-11	3.8 A	-	-
LA8-P	LA180 Control	Quad	1	5-19	5-19, 22-39	5-19	4-10	4-12	4-20	4-12	4-20	1.0 A	-	-
LE8-XX	Line Printer Control	Quad	1	5-19	5-19, 22-39	5-19	2-10	2-12	2-20	2-12	2-20	0.35 A	-	-
LS8-F	Line Printer Control	Quad	1	5-19	5-19, 22-39	5-19	2-10	2-12	2-20	2-12	2-20	0.40 A	-	-
MI8-E	Bootstrap Loader	Quad	1	5-19	5-19, 22-39	5-19	4-10	4-12	4-20	4-12	4-20	0.75 A	-	0.05 A
MM8-AA	8K Core RAM	Hex	2 ⁴	-	-	-	-	4-8	4-11	4-8	4-11	2.5 A	-	-
MM8-AB	16K Core RAM	Hex	2 ⁴	-	-	-	-	4-8	4-11	4-8	4-11	2.5 A	-	-
MM8-E (See Rule 8)	4K Core RAM Operating Standby	Quad	3	Next to bus loads	Next to bus loads	Next to bus loads	-	-	-	-	-	2.2 A 1.02 A	-	3.3 A 0.24 A
MM8-EJ (See Rule 8)	8K Core RAM Operating Standby	Quad	3	Next to bus loads	Next to bus loads	Next to bus loads	-	-	-	-	-	2.3 A 1.6 A	-	3.5 A 0.37 A
MR8-AA	1K ROM	Quad	1	5-19	5-19, 22-39	5-19	2-10	-	-	-	-	2.0 A	-	-
MR8-AB	2K ROM	Quad	1	5-19	5-19, 22-39	5-19	2-10	-	-	-	-	3.0 A	-	-
MR8-AC	3K ROM	Quad	1	5-19	5-19, 22-39	5-19	2-10	-	-	-	-	4.0 A	-	-
MR8-AD	4K ROM	Quad	1	5-19	5-19, 22-39	5-19	2-10	-	-	-	-	5.0 A	-	-
MR8-FB	1K PROM	Quad	1	5-19	5-19, 22-39	5-19	2-10	-	-	-	-	3.8 A	-	0.35 A
MS8-AA	1K RAM	Quad	1	-	-	-	4-10	-	-	-	-	1.4 A	-	-
MS8-AB	2K RAM	Quad	1	-	-	-	4-10	-	-	-	-	2.1 A	-	-
MS8-AC	3K RAM	Quad	1	-	-	-	4-10	-	-	-	-	2.8 A	-	-
MS8-AD	4K RAM	Quad	1	-	-	-	4-10	-	-	-	-	3.5 A	-	-
MS8-CA	16K MOS RAM Operating Standby	Hex	1	-	-	-	-	4-8	4-11	4-8	4-11	4.5 A 4.0 A	-	0.7 A 0.7 A
MS8-CB	32K MOS RAM Operating Standby	Hex	1	-	-	-	-	4-8	4-11	4-8	4-11	5.1 A 4.6 A	-	0.7 A 0.7 A
PC8-E, PR8-E	Reader/Punch Control	Quad	1	5-19	5-19, 22-39	5-19	4-10	4-12	4-20	4-12	4-20	0.84 A	-	0.05 A
RK8-EA	RK05 Control	Quad	3	5-19	5-19, 22-39	5-19	4-10	4-12	4-20	4-12	4-20	3.10 A	-	-
RX8-E	RX01 Control	Quad	1	5-19	5-19, 22-39	5-19	4-10	4-12	4-20	4-12	4-20	1.5 A	-	-
TA8-AA	TU60 Control	Quad	1	5-19	5-19, 22-39	5-19	2-10	2-12	2-20	2-12	2-20	2.80 A	-	-
TA8-EA, FA	TU10 Control	Quad	4	5-19	5-19, 22-39	5-19	4-10	4-12	4-20	4-12	4-20	4.10 A	-	-

Table 2-1 PDP-8 Module Placement Chart (Cont)

Option	Description	Board Size	Number of Slots Used	Assigned Slot Number in Basic Chassis								Current Requirements		
				PDP-8/E		PDP-8/M	PDP-8/A					+5 V	+15 V	-15 V
				1 Omnibus	2 Omnibuses		8A100	8A205 8A400 8A405	8A420 8A425	8A600	8A620 8A625			
TD8-E	TU56 Control	Quad	1	5-19	5-19, 22-39	5-19	-	-	-	4-12	4-20	1.3 A	-	-
TM8-E	TU10 Control	Quad	4	5-19	5-19, 22-39	5-19	4-10	4-12	4-20	4-12	4-20	4.2 A	-	-
VC8-E	Display Control	Quad	2	5-19	5-19, 22-39	5-19	2-10	2-12	2-20	2-12	2-20	0.31 A	-	-
VK8-A	Video Display Control	Hex	1	-	-	-	4-10	4-12	4-20	4-12	4-20	2.8 A	-	-
VT8-E	Display Control	Quad	3	5-19	5-19, 22-39	5-19	4-10	4-12	4-20	4-12	4-20	3.7 A	0.09 A	0.13 A
XY8-E	Plotter Control	Quad	1	5-19	5-19, 22-39	5-19	4-10	4-12	4-20	4-12	4-20	0.42 A	0.01 A	0.03 A

¹ An RFI shield is used with a KK8-E CPU; when the KK8-E is used in an 8A600 or 8A620, the RFI shield is not needed and the CPU is designated KK8-F.

² If a KE8-E option is used with the PDP-8/E or PDP-8/M, the M8310 and M8300 modules and the KM8-E option are moved to slots 5, 6, and 7, respectively.

³ If a KE8-E option is used with the 8A600, the M8300 and M8310 modules are moved to slots 8 and 9, respectively; if the option is used with an 8A620, M8300 and M8310 move to slots 16 and 17, respectively.

⁴ MM8-A inserts in only one Omnibus slot but uses the space of 2 slots, e.g., if plugged into slot 8, the MM8-A uses the space above slot 9, preventing a module from being inserted in slot 9.

⁵ The KT8-A can be used in an H9300 chassis only if the four bank select signal pins (EB2, ED2, EL2, and ER2) on the Omnibus E connectors are bussed. Chassis that have not been manufactured with these pins bussed can be modified in the field; contact the Digital representative for information.

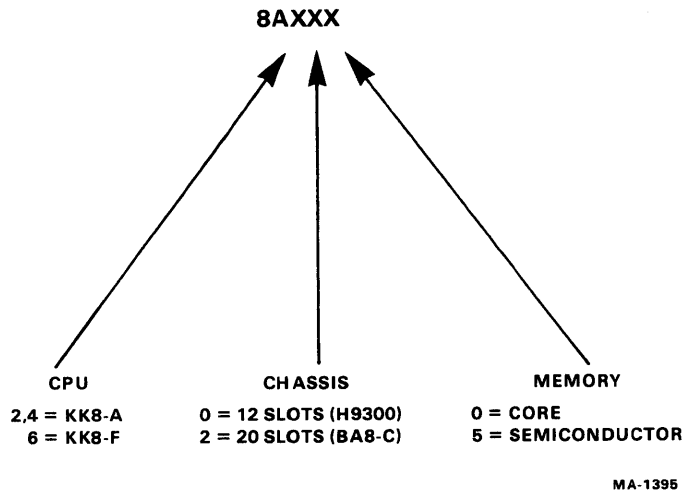

Figure 2-1 PDP-8/A Computer Designations

2.2 MODULE PLACEMENT RULES

1. In a PDP-8/A Omnibus, insert quad modules from the bottom up, i.e., from slot 10, slot 12, or slot 20 toward slot 1; insert hex modules from the top down. (When a quad module is inserted in a slot, that slot's card guide on the left side of the chassis – when viewing the chassis from the front – must be removed to prevent interference with module top connectors.) There can be empty slots between hex modules and quad modules but there must be no empty slots between quad modules. The bus loads module (M8320) is the one quad module that will always be located above hex modules. All other quad modules should be located below hex modules, although there are situations when this is not possible.
2. Modules must be inserted in the Omnibus so that the module connectors coincide with the Omnibus connectors. For example, module connector A must be inserted in Omnibus connector A, and no other. Module connector A is on the right side of the module when viewing the component side with the connector fingers pointing down; Omnibus connector A is on the right side when looking from the front of a PDP-8/E or PDP-8/M, but on the left side when looking from the front of a PDP-8/A. Thus, modules are inserted with the component side toward the front of a PDP-8/E or PDP-8/M, and toward the top of a PDP-8/A.
3. Omnibus connector E is reserved for PDP-8/A memory signals; hence, no module (other than MM8-A and MS8-C memory, and KT8-A memory management) that has signals on its E connector should be inserted in either slots 4 through 8 of the H9300 chassis or slots 4 through 11 of the BA8-C chassis.
4. The signals dedicated to certain pins on the PDP-8/A Omnibus are not the same for all slots. Several pins in slots 1, 2, and 3 carry signals unique to these slots. (Refer to Chapter 3 of the *PDP-8/A Miniprocessor Users Manual*.) Consequently, user-designed modules will function in slots 1, 2, and 3 of a PDP-8/A computer only if these differences have been considered during design of such a module.
5. An M8320 module must be modified before it can be installed in either a BA8-C or an H9300 Omnibus. The modification is described in DEC ECO M8320-00007; if it has been effected, resistor R55 will have been removed.

6. If a KL8-A (M8319) is to be installed in the system, not only the KL8-A but also the M8300 and M8310 modules must be modified. The changes to the M8300 and M8310 modules are described in DEC ECOs M8300-00005 and M8310-00008, respectively; if the changes have been made, the 0.01 μ F bypass capacitors will have been replaced by 0.22 μ F capacitors. The modification of the KL8-A module is described by DEC ECO M8319-00003; if it has been carried out, IC E52 will have been changed from a 74123 to a 74LS221 and capacitor C5 will have been changed from 22 pF to 10 pF.
7. The first memory unit should be placed as far from the CPU as possible. Memory should then expand in the direction of the CPU.
8. The MM8-E and MM8-EJ memories each comprise three modules; these are a sense/inhibit module, a memory stack module, and an X/Y driver module. The three modules are inserted in the three slots next to the M8320 module, with the memory stack module in the middle. (Either of the other two can be next to the M8320.) If a second memory is in the system, it is placed in the three slots next to the first memory, and so on.
9. Do not mix MM8-E and MM8-A memories in a system.
10. MM8-E memory resides in a PDP-8/E or PDP-8/M Omnibus, while MM8-A memory resides in a PDP-8/A Omnibus.
11. When MM8-AB core memories are used in a system that includes a KT8-A memory management option, the memory modules must be modified in accordance with DEC ECO MM8-AB, No. 7.
12. Place a KM8-E option next to the KK8-E or KK8-F CPU; place the KM8-A option in slot 2 or slot 3.
13. Data break devices can be located only between the CPU and the first memory element. (This often results in a conflict with rule 1, which should then be ignored.) Programmed I/O device modules can be located in any vacant slot in the system.
14. The BA8-C chassis has a 20-slot Omnibus and a power supply that includes two G8018 regulators. One regulator provides power for the top ten Omnibus slots, while the other regulator provides power for the bottom ten slots. Multiboard options (e.g., the FPP8-A, which comprises two modules) should be inserted in a BA8-C chassis so that each module of the option draws current from the same power supply regulator.

2.3 OPTION CONFIGURATION WORKSHEETS

The rest of Chapter 2 consists of worksheets that enable a user to plan an option configuration for each computer type. Each worksheet includes a representation of the Omnibus contained in the pertinent computer. Options that must be included in the Omnibus are already entered in the slots assigned to them. The user chooses additional options that meet his system requirements and enters the designations in the appropriate slots. The selection and placement of options must satisfy the guidelines and rules already introduced. When the system is complete, add the current requirements and make sure the total current available is adequate for the system devised.

Weight

PDP-8/E	41 kg (90 lb)
PDP-8/M	16 kg (35 lb)

Heat Dissipated

PDP-8/E	4095 Btu/h
PDP-8/M	2048 Btu/h

AC Power Requirement

PDP-8/E	1200 W max
PDP-8/M	600 W max

Dimensions

PDP-8/E	26.7 cm H × 48.3 cm W × 58.4 cm D (10.5 in H × 19 in W × 23 in D)
PDP-8/M	26.7 cm H × 48.3 cm W × 33 cm D (10.5 in H × 19 in W × 13 in D)

NOTES

- Total current for KK8-E modules (M8320, M8300, M8310, and M8330) is listed with M8330.
- The KM8-E is required when more than 4K of memory is in the system.
- If a KE8-E is used, it is inserted in slots 3 (M8340) and 4 (M8341). The M8310, M8300, and KM8-E are moved to slots 5, 6, and 7, respectively.
- If more than one memory unit is used, the Omnibus is filled from slot 16 up.
- An M849 RFI shield must be inserted between memory and non-memory options. For example, if only one MM8-E unit is in the system, the RFI shield must be placed in slot 16.
- A second BE8-A Omnibus can be installed in a PDP-8/E. Slot 20 and slot 21 are connected with M935 interconnecting cards. The M8320 is placed in slot 40, and the first memory unit is placed in slots 37, 38, and 39. The available current remains the same.
- A PDP-8/M can be equipped with an operator's panel rather than a programmer's console (KC8-E). The panel does not insert into the Omnibus; hence, the M8330, M8310, M8300, and KM8-E modules would be placed in slots 1, 2, 3, and 4, respectively. If a KE8-E is used, it is inserted in slots 2 and 3, while the M8310, M8300, and KM8-E modules move to slots 4, 5, and 6.

PDP-8/E or PDP-8/M

Slot	Module	Size	Current		
			+5 V	+15 V	-15 V
1	KC8-E	Quad	2.0	0	0
2	M8330	Quad	4.5	1.0	0.53
3	M8310	Quad			
4	M8300	Quad			
5	KM8-E	Quad	1.0	0	0
6					
7					
8					
9					
10					
11					
12					
13					
14					
15					
16					
17	MM8-E/EJ	Triple	See Table 2-1		
18		Quad			
19					
20	M8320	Quad			
Total Current					
Available Current			20.0	2.0	8.0
Remaining Current					

**8A100
(H9300 CHASSIS)**

Weight

25 kg (55 lb)

AC Power Required

400 W max

Heat Dissipated

1365 Btu/h

Dimensions

26.7 cm H X 48.3 cm W X 26.7 cm D
(10.5 in H X 19 in W X 10.5 in D)

NOTES

1. Memory can be MS8-A or MR8-A, with capacities ranging from 1K to 4K. In RAM/ROM combinations, the MR8-A must mount next to the MS8-A. Memory can be inserted anywhere on the bus consistent with the general rules of module placement.
2. If more than 4K of memory is used, a KM8-A must be included. The KM8-A should be placed in slot 2.
3. If a DKC8-A is used, it is inserted in slot 2 or slot 3 (interchangeable with KM8-A).
4. The sum of +15 V current and -15 V current cannot exceed 1 A.

Slot	Module	Size	Current		
			+5 V	+15 V	-15 V
1	KK8-A	Hex	5.0	0	0.04
2					
3					
4					
5					
6					
7					
8					
9					
10					
11		Quad			
12		Quad			
If KC8-A is used, add 2.5 A to +5 V.				0	0
Total Current					
Available Current			20.0	0.75 (Note 4)	0.75 (Note 4)
Remaining Current					

**8A205, 8A400, 8A405
(H9300 CHASSIS)**

Weight

25 kg (55 lb)

AC Power Required

550 W max

Heat Dissipated

1880 Btu/h

Dimensions

26.7 cm H × 48.3 cm W × 26.7 cm D
(10.5 in H × 19 in W × 10.5 in D)

NOTES

1. Only quad modules will fit in slots 11 and 12.
2. Memories are built from slot 8 to slot 4. (An MM8-A memory unit inserted in slot 8 prevents slot 9 from being used.)
3. If more than 4K of memory is desired, memory extension capability can be provided by either the KM8-A, the KM8-E, or the KT8-A* options. A KM8-A is inserted in slot 2 or slot 3. If a KM8-E is used, it should be placed as close as possible to the KK8-A, consistent with the general rules of module placement. For example, if the KM8-E is the only quad module present, it should be in slot 12; if quad modules already occupy slots 10 through 12, the KM8-E should be in slot 9. (Quad modules should not be placed above hex modules.)

A KT8-A can be used only with MM8-AB, MS8-CA, and MS8-CB memories. Insert the KT8-A in any slot that has an E connector (i.e., slots 4–8). If a power-fail/auto-restart feature and/or bootstrap capability are required for the system that contains a KT8-A, a KM8-AC can be used. (The KM8-E and the KT8-A are not

compatible.) However, the KM8-AC memory extension and time-share function must be disabled. [Refer to the *KT8-A Memory Management Control User's Guide* (EK-KT08A-UG-001) for directions.]

4. A DKC8-A is inserted in slot 2 or slot 3 (interchangeable with KM8-A).
5. If an FPP8-A (double hex) is to be installed in the system, it should be placed as close as possible to memory, but between memory and the CPU.

Slot	Module	Size	Current		
			+5 V	+15 V	-15 V
1	KK8-A	Hex	5.0	0	0.04
2					
3					
4					
5					
6					
7					
8					
9					
10					
11		Quad			
12		Quad			
If KC8-A is used, add 2.5 A to +5 V.				0	0
Total Current					
Available Current			25.0	2.0	2.0
Remaining Current					

* Refer to Table 2-1, Note 5.

**8A420, 8A425
(BA8-C CHASSIS)**

Weight

54 kg (120 lb)

AC Power Required

1100 W max

Heat Dissipated

3760 Btu/h

Dimensions

26.7 cm H X 48.3 cm W X 58.4 cm D
(10.5 in H X 19 in W X 23 in D)

NOTES

1. The BA8-C power supply consists of two G8018 regulators; one provides 25 A at +5 Vdc, 2 A at +15 Vdc, and 2 A at -15 Vdc for the top 10 slots, while the other provides the same current for the bottom 10 slots. As much as possible, modules should be distributed so that the current drain from each regulator is approximately equal. This means that there can be gaps between hex modules and between the hex-module group and the quad-module group; however, there must be no gaps between quad modules.
2. Memories are built from slot 11 to slot 4. (An MM8-A memory unit inserted in slot 11 prevents slot 12 from being used).
3. If more than 4K of memory is desired, memory extension capability can be provided by either the KM8-A, the KM8-E, or the KT8-A options. A KM8-A is inserted in slot 2 or slot 3. If a KM8-E is used, it should be placed as close as possible to the KK8-A, consistent with the general rules of module placement. For example, if the KM8-E is the only quad module present, it should be in slot 20; if quad modules already occupy slots 15 through 20, the KM8-E should be placed in slot 14. (Quad modules should not be placed above hex modules.)

A KT8-A can be used only with MM8-AB, MS8-CA, and MS8-CB memories. Insert the KT8-A in any slot that has an E connector (i.e., slots 4-11). If a power-fail/auto-restart feature and/or bootstrap capability are required for the system that contains a KT8-A, a KM8-AC can be used. (The KM8-E and KT8-A are not compatible.) However, the KM8-AC memory extension and time-share function must be

disabled. [Refer to the *KT8-A Memory Management Control User's Guide* (EK-KT08A-UG-001) for directions.]

4. A DKC8-A is placed in slot 2 or slot 3. (The DKC8-A and the KM8-A are interchangeable in slots 2 and 3.)
5. If an FPP8-A is installed in the system, it should be placed as close to memory as possible, but between memory and the CPU.

Slot	Module	Size	Current		
			+5 V	+15 V	-15 V
1	KK8-A	Hex	5.0	0	0.04
2					
3					
4					
5					
6					
7					
8					
9					
10					
If KC8-A is used, add 2.5 A to +5 V.				0	0
Total Current (1-10)					
Available Current (1-10)			25.0	2.0	2.0
Remaining Current (1-10)					
11					
12					
13					
14					
15					
16					
17					
18					
19					
20					
Total Current (11-20)					
Available Current (11-20)			25.0	2.0	2.0
Remaining Current (11-20)					

8A600
(H9300 CHASSIS)

Weight
25 kg (55 lb)

AC Power Required
550 W max

Heat Dissipated
1880 Btu/h

Dimensions
26.7 cm H × 48.3 cm W × 26.7 cm D
(10.5 in H × 19 in W × 10.5 in D)

NOTES

1. KK8-F modules' total current is listed with the M8330 module.
2. Memories are built from slot 4 to slot 8. (A memory unit inserted in slot 8 prevents slot 9 from being used.)
3. If more than 4K of memory is desired, memory extension capability can be provided by either the KM8-A, the KM8-E, or the KT8-A* options. A KM8-A is inserted in slot 2 or slot 3. If a KM8-E is used, it is placed in slot 9 (slot 7 if a KE8-E is in the system).

A KT8-A can be used only with MM8-AB, MS8-CA, and MS8-CB memories. Insert the KT8-A in any slot that has an E connector (i.e., slots 4–8). If a power-fail/auto-restart feature and/or bootstrap capability are required for the system that contains a KT8-A, a KM8-AC can be used. (The KM8-E and KT8-A are not compatible.) However, the KM8-AC memory extension and time-share function must be disabled. [Refer to the *KT8-A Memory Management Control User's Guide* (EK-KT08A-UG-001) for directions.]

4. If a DKC8-A is used, it is placed in slot 3 (interchangeable with KM8-A).
5. If a KE8-E is used, the M8300 and M8310 modules are moved to slot 8 and slot 9, respectively.

Slot	Module	Size	Current		
			+5 V	+15 V	-15 V
1	M8320	Quad	Note 1	Note 1	Note 1
2	KM8-A	Hex	2.0	0	0
3					
4					
5					
6					
7					
8					
9					
10	M8300	Quad	Note 1	Note 1	Note 1
11	M8310	Quad	Note 1	Note 1	Note 1
12	M8330	Quad	4.5	1.0	0.53
If KC8-A is used, add 2.5 A to +5 V.				0	0
Total Current					
Available Current			25.0	2.0	2.0
Remaining Current					

*Refer to Table 2-1, Note 5.

**8A620, 8A625
(BA8-C CHASSIS)**

Weight

54 kg (120 lb)

AC Power Required

1100 W max

Heat Dissipated

3760 Btu/h

Dimensions

26.7 cm H × 48.3 cm W × 58.4 cm D
(10.5 in H × 19 in W × 23 in D)

NOTES

1. The BA8-C power supply consists of two G8018 regulators; one provides 25 A at +5 Vdc, 2 A at +15 Vdc, and 2 A at -15 Vdc for the top 10 slots, while the other provides the same current for the bottom 10 slots. As much as possible, modules should be distributed so that the current drain from each regulator is approximately equal. This means that there can be gaps between hex modules and between the hex-module group and the quad-module group; however, there must be no gaps between quad modules.
2. KK8-F modules' total current is listed with the M8330 module.
3. Memories are built from slot 4 to slot 11. (An MM8-A memory unit inserted in slot 10 prevents slot 11 from being used; current drawn is charged to the top 10 slots.)
4. If more than 4K of memory is desired, memory extension capability can be provided by either the KM8-A, the KM8-E, or the KT8-A options. A KM8-A is inserted in slot 2 or slot 3. If a KM8-E is used, it is placed in slot 17 (slot 15 if a KE8-E is in the system).

A KT8-A can be used only with MM8-AB, MS8-CA, and MS8-CB memories. Insert the KT8-A in any slot that has an E connector (i.e., slots 4-11). If a power-fail/auto-restart feature and/or bootstrap capability are required for the system that contains a KT8-A, a KM8-

AC can be used. (The KM8-E and KT8-A are not compatible.) However, the KM8-AC memory extension and time-share function must be disabled. (Refer to the *KT8-A Memory Management Control User's Guide* (EK-KT08A-UG-001) for directions.]

5. A DKC8-A is inserted in slot 2 or slot 3 (interchangeable with KM8-A).
6. If a KE8-E is used, the M8300 and M8310 modules move to slot 16 and slot 17, respectively.

Slot	Module	Size	Current		
			+5 V	+15 V	-15 V
1	M8320	Quad	Note 2	Note 2	Note 2
2					
3					
4					
5					
6					
7					
8					
9					
10					
If KC8-A is used, add 2.5 A to +5 V.				0	0
Total Current (1-10)					
Available Current (1-10)			25.0	2.0	2.0
Remaining Current (1-10)					
11					
12					
13					
14					
15					
16					
17					
18	M8300	Quad	Note 2	Note 2	Note 2
19	M8310	Quad	Note 2	Note 2	Note 2
20	M8330	Quad	4.5	1.0	0.53
Total Current (11-20)					
Available Current (11-20)			25.0	2.0	2.0
Remaining Current (11-20)					

CHAPTER 3 SYSTEM EXPANSION

3.1 INTRODUCTION

The PDP-8/E, PDP-8/M, 8A600, 8A620, and 8A625 computers can be expanded with H9300 and BA8-C chassis assemblies. Figure 3-1 illustrates the expansion possibilities available with these PDP-8 family computers. The numbers in parentheses indicate the number of Omnibus slots that are empty after a KK8-E or a KK8-F (and a programmer's console, if applicable) has been installed in the Omnibus. For example, a PDP-8/E with a single Omnibus has 15 empty slots after the programmer's console and the KK8-E are inserted in the appropriate Omnibus slots. If a BA8-C is connected to the PDP-8/E, the system capacity is more than doubled and 33 slots are available for module installation. Each of the expansion possibilities outlined in Figure 3-1 is examined in more detail in Figures 3-2 through 3-7; configuration worksheets for expanded systems are included in Paragraph 3.3.

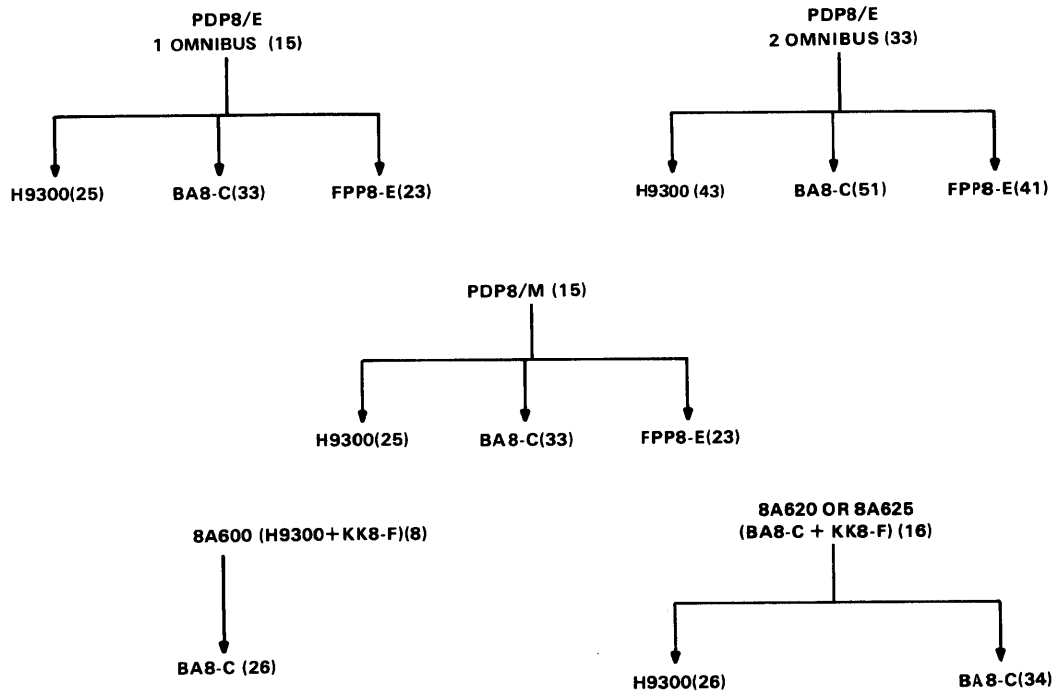

NOTE:
NUMBERS IN PARENTHESES INDICATE THE NUMBER OF OMNIBUS SLOTS THAT ARE EMPTY AFTER A KK8-E OR A KK8-F (AND A PROGRAMMER'S CONSOLE, IF APPLICABLE) HAS BEEN INSTALLED IN THE OMNIBUS.

MA-0434

Figure 3-1 PDP-8 Family Expansion Possibilities

**PDP-8/E + H9300
+ BA8-C + FPP8-E**

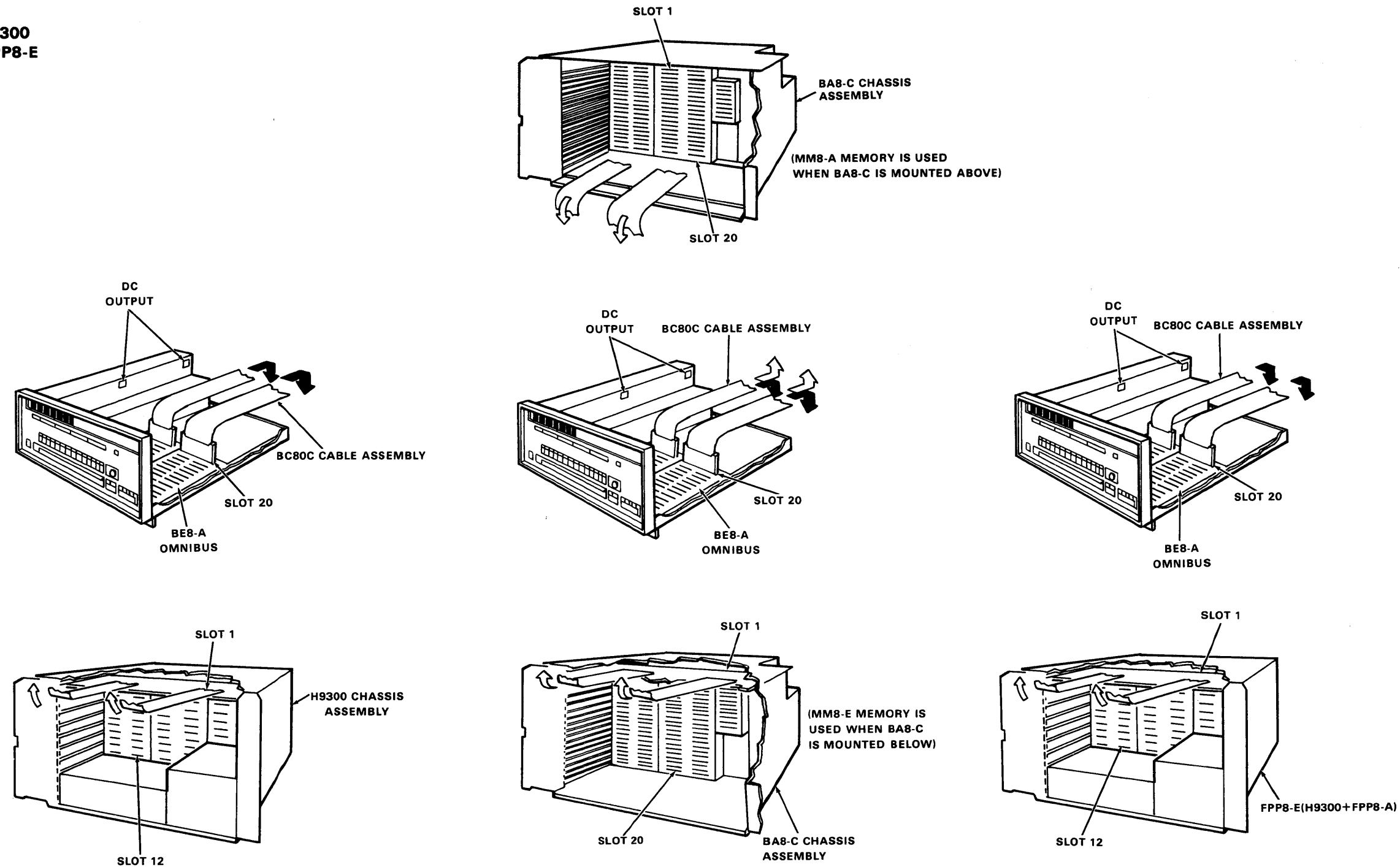

1. H9300 MOUNTS BELOW PDP8/E.
2. EITHER MM8-E OR MM8-A MEMORY (BUT NOT BOTH) CAN BE USED.
3. 25 SLOTS AVAILABLE (AFTER PROGRAMMER'S CONSOLE AND KK8-E ARE INSTALLED).

1. BA8-C MOUNTS ABOVE OR BELOW PDP8/E, DEPENDING ON TYPE OF MEMORY USED; EITHER MM8-E OR MM8-A (BUT NOT BOTH) CAN BE USED.
2. 33 SLOTS AVAILABLE (AFTER PROGRAMMER'S CONSOLE AND KK8-E ARE INSTALLED).

1. FPP8-E MOUNTS BELOW PDP8/E.
2. EITHER MM8-E OR MM8-A MEMORY (BUT NOT BOTH) CAN BE USED.
3. 23 SLOTS AVAILABLE (AFTER PROGRAMMER'S CONSOLE, KK8-E, AND FPP8-A ARE INSTALLED).

MA-0439

Figure 3-2 PDP-8/E (1-Omnibus) Expansion

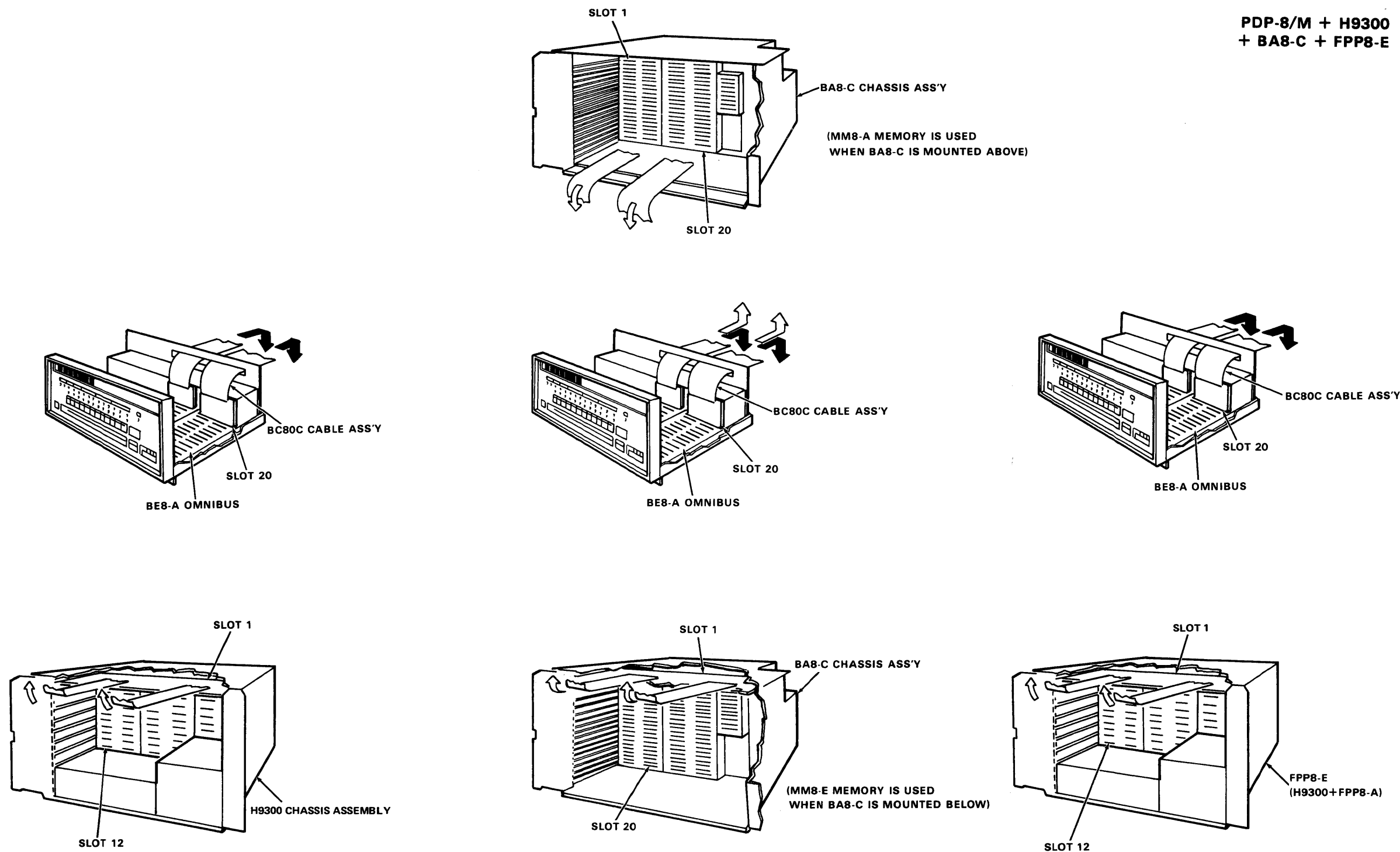

1. H9300 MOUNTS BELOW PDP8/M
2. EITHER MM8-E OR MM8-A MEMORY (BUT NOT BOTH) CAN BE USED.
3. 25 SLOTS AVAILABLE (AFTER PROGRAMMER'S CONSOLE AND KK8-E ARE INSTALLED)

1. BA8-C MOUNTS ABOVE OR BELOW PDP8/M, DEPENDING ON TYPE OF MEMORY USED; EITHER MM8-E OR MM8-A (BUT NOT BOTH) CAN BE USED.
2. 33 SLOTS AVAILABLE (AFTER PROGRAMMER'S CONSOLE AND KK8-E ARE INSTALLED).

1. FPP8-E MOUNTS BELOW PDP8/M.
2. EITHER MM8-E OR MM8-A MEMORY (BUT NOT BOTH) CAN BE USED.
3. 23 SLOTS AVAILABLE (AFTER PROGRAMMER'S CONSOLE, KK8-E, AND FPP8-A ARE INSTALLED).

MA-0440

Figure 3-3 PDP-8/M Expansion

**PDP-8/E + H9300
+ BA8-C + FPP8-E**

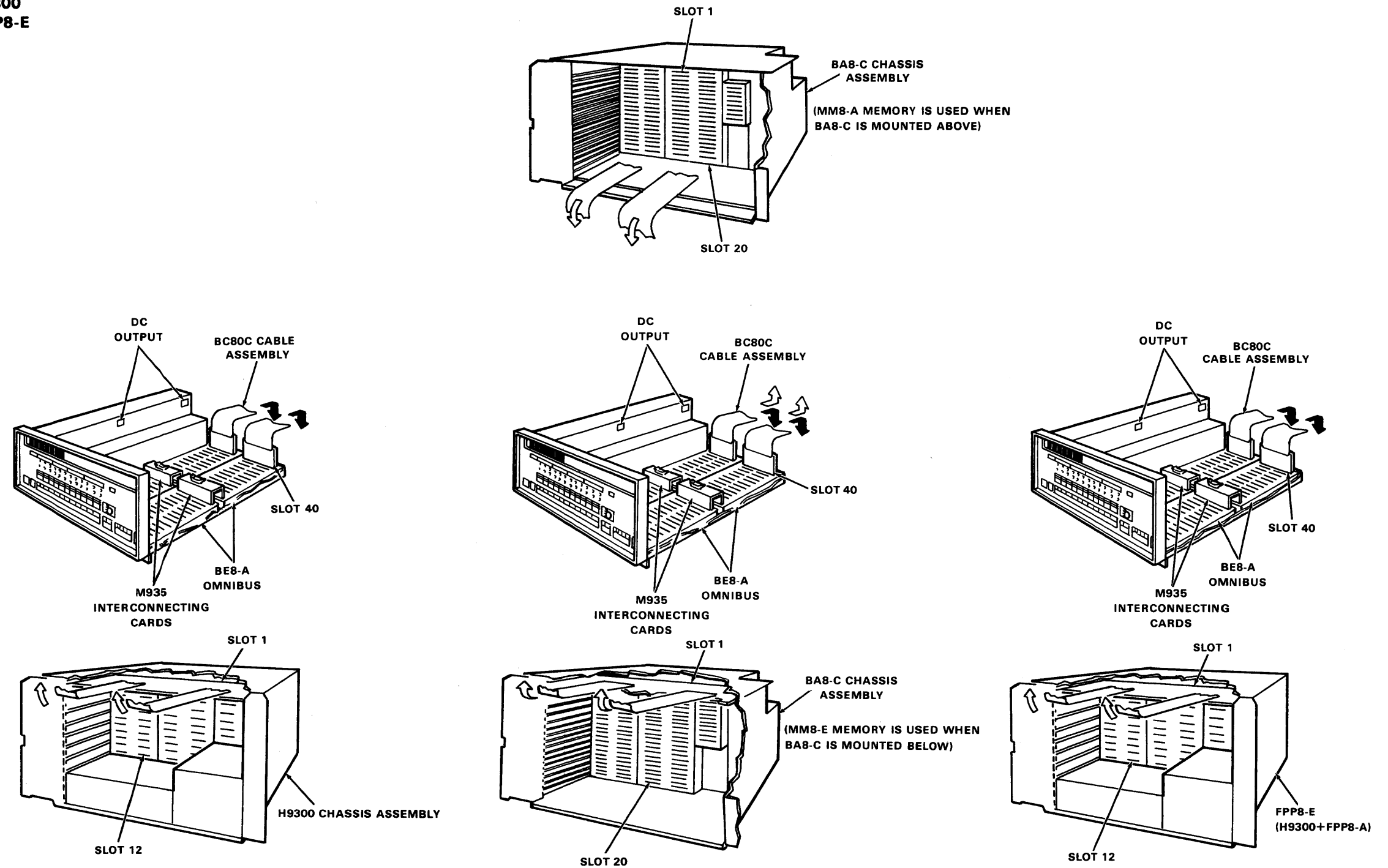

1. H9300 MOUNTS BELOW PDP8/E
2. EITHER MM8-E OR MM8-A MEMORY (BUT NOT BOTH) CAN BE USED.
3. 43 SLOTS AVAILABLE (AFTER PROGRAMMER'S CONSOLE AND KK8-E ARE INSTALLED).

1. BA8-C MOUNTS ABOVE OR BELOW PDP8/E, DEPENDING ON TYPE OF MEMORY USED; EITHER MM8-E OR MM8-A (BUT NOT BOTH) CAN BE USED.
2. 51 SLOTS AVAILABLE (AFTER PROGRAMMER'S CONSOLE AND KK8-E ARE INSTALLED).

1. FPP8-E MOUNTS BELOW PDP8/E.
2. EITHER MM8-E OR MM8-A MEMORY (BUT NOT BOTH) CAN BE USED.
3. 41 SLOTS AVAILABLE (AFTER PROGRAMMER'S CONSOLE, KK8-E, AND FPP8-A ARE INSTALLED).

MA-0438

Figure 3-4 PDP-8/E (2-Omnibus) Expansion

8A600 + BA8-C

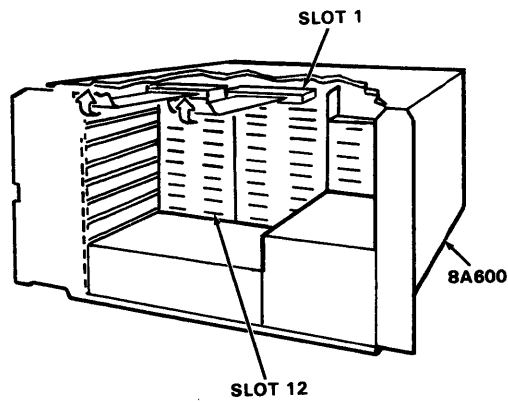
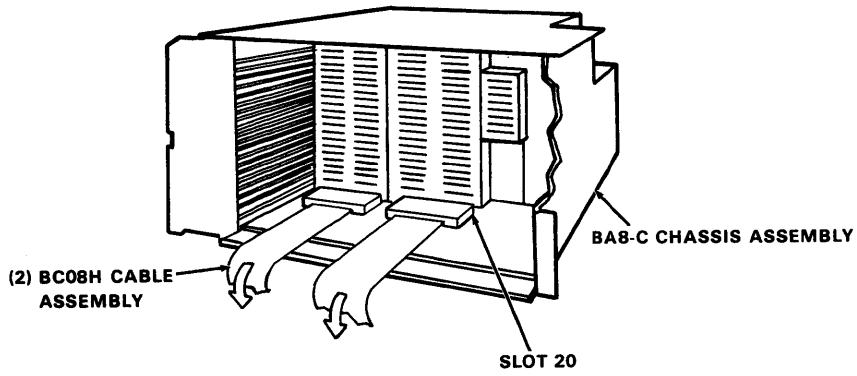

1. BA8-C MOUNTS ABOVE 8A600.
2. ONLY MM8-A MEMORY CAN BE USED.
3. 26 SLOTS AVAILABLE (AFTER KK8-F IS INSTALLED).

MA-0436

Figure 3-5 8A600 Expansion

8A620 OR 8A625 + H9300

**8A620
+H9300**

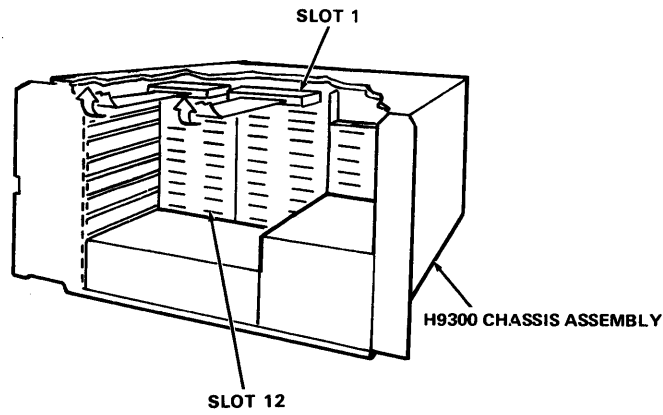
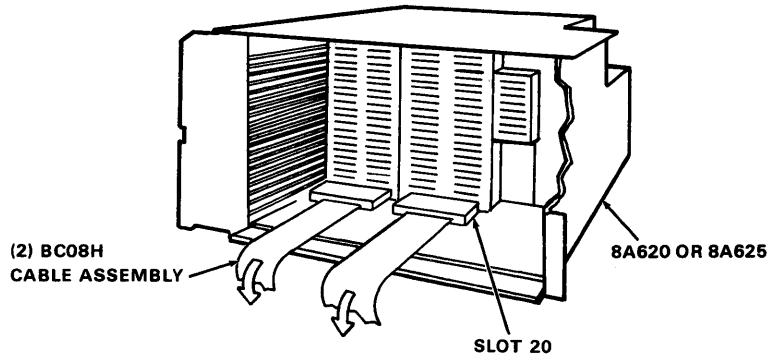

1. H9300 MOUNTS BELOW 8A620.
2. MM8-A OR MS8-C MEMORY CAN BE USED.
3. 26 SLOTS AVAILABLE (AFTER KK8-F IS INSTALLED).

MA-0437

Figure 3-6 8A620 or 8A625 (+ H9300) Expansion

8A620 OR 8A625 + BA8-C

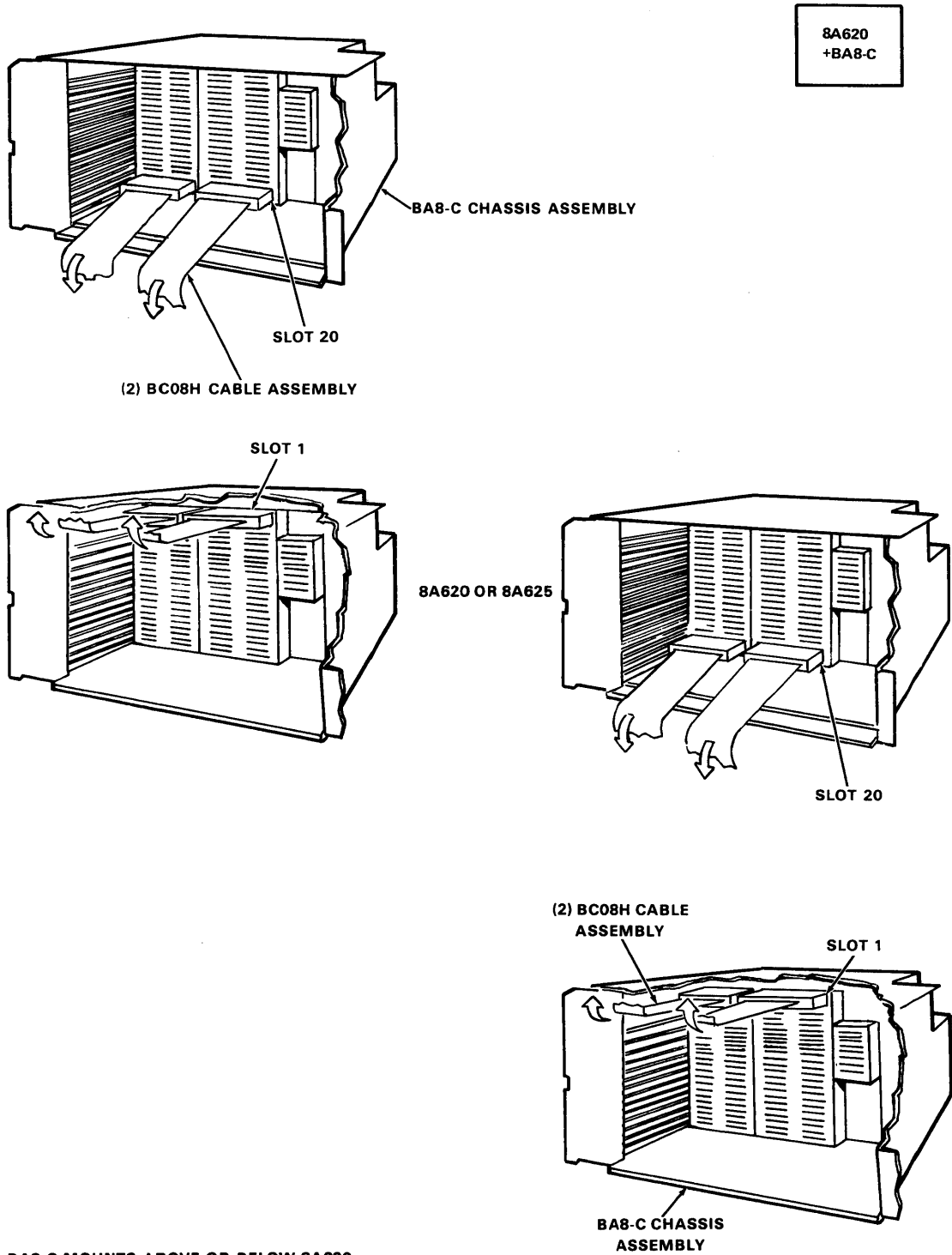

1. BA8-C MOUNTS ABOVE OR BELOW 8A620.
2. MM8-A OR MS8-C MEMORY CAN BE USED.
3. 34 SLOTS AVAILABLE (AFTER KK8-F IS INSTALLED).

MA-0435

Figure 3-7 8A620 or 8A625 (+ BA8-C) Expansion

Note in Figures 3-2 through 3-7 that two types of expansion cable assemblies are used. A BC80C cable assembly is used for PDP-8/E and PDP-8/M expansion, while two BC08H cable assemblies are needed to expand an 8A600 or an 8A620 computer. When installing the BC80C assembly, insert the hex-size module in the Omnibus of the H9300 or BA8-C chassis. Two ribbon cables, identified as "Cable 1" and "Cable 3," are attached to the hex board. The paddleboard on the end of Cable 1 should be inserted into Omnibus connectors A and B of the PDP-8/E or PDP-8/M, while the paddleboard on the end of Cable 3 should be inserted into Omnibus connectors C and D. The BC08H assemblies should be installed to connect A and B of one Omnibus to A and B of the other Omnibus, and the same with connectors C and D.

3.2 MODULE PLACEMENT RULES FOR EXPANDED SYSTEMS

The module placement rules (Paragraph 2.2) apply to an individual chassis. Since an expanded system comprises two individual chassis, these rules are still relevant; however, some of the rules must be qualified. These qualified rules, together with some rules that apply only to expanded systems, follow.

1. Quad modules are inserted in an H9300 or BA8-C chassis from the bottom up; hex modules are inserted from the top down. This applies only to individual boxes and not to a system, e.g., when an 8A620 is expanded with an H9300 chassis, quad-from-the-bottom, hex-from-the-top applies to each box alone.
2. Only the KK8-E or KK8-F CPU can be used in expanded systems.
3. Put the KM8-E next to the CPU; put the KM8-A in the same box as the CPU, if there is a choice.
4. Generally, memory and CPU cannot reside in the same chassis; however, in a system that contains a KT8-A memory management option, memory can be located in both system boxes. In such an expanded system, an M9020 terminator module must be installed in any empty E connector of the box *not* containing the KT8-A module. A cable (70-11411-1J) is then plugged into a Berg connector on both the M9020 module and the KT8-A module, making the bank select signals available on the E connectors of both boxes. (Refer to Table 2-1, Note 5.)
5. All memory must reside in the box that contains the M8320 module, except in systems that contain a KT8-A option. MM8-E memory goes in a PDP-8/E or PDP-8/M Omnibus, while MM8-A or MS8-C memory goes only in an H9300 or BA8-C Omnibus.
6. If power-failure detection is desired with an expanded PDP-8/E or PDP-8/M, the KM8-A option must be used. The KP8-E option cannot be used in the expanded system.
7. When a BA8-C chassis is used to expand a PDP-8/E or PDP-8/M computer, remove jumper W1 from the BA8-C power distribution board (P/N 5412946).

3.3 OPTION CONFIGURATION WORKSHEETS FOR EXPANDED SYSTEMS

Worksheets for expanded systems comprise the rest of Chapter 3. They should be used similarly to those for single-chassis systems. The expanded-system worksheets depict the Omnibuses of both the basic chassis and the expander chassis. Required options are already entered in the appropriate positions. Additional system options should be entered according to the rules and guidelines specified.

**PDP-8/E OR PDP-8/M + BA8-C
(EXPANDER MOUNTED
ABOVE PDP-8/E OR PDP-8/M)**

NOTES

1. Only MM8-A memory can be used in this configuration (i.e., BA8-C mounted above).
2. Total current for K8-E modules (M8320, M8330, M8310, and M8300) is listed with M8330.
3. If a KM8-E is used instead of a KM8-A, it should be placed in slot 5 of the PDP-8/E or PDP-8/M (or slot 7 if a KE8-E is in the system).
4. Data break device modules cannot be inserted in slot 2 or slot 3 of the BA8-C.
5. An RFI shield is not used in this configuration.
6. Additional memory units are installed from slot 6 down; the MM8-A cannot be placed in the PDP-8/E or PDP-8/M.
7. BC80C cable assemblies connect slot 20 of the PDP-8/E or PDP-8/M and slot 20 of the BA8-C. (The expander must mount above the PDP-8/E or PDP-8/M.)
8. The BA8-C power supply consists of two G8018 regulators; one provides 25 A at +5 Vdc, 2 A at +15 Vdc, and 2 A at -15 Vdc for the top 10 slots, while the other provides the same current for the bottom 10 slots. As much as possible, modules should be distributed so that the current drain from each regulator is approximately equal. This means that there can be gaps between hex modules and between the hex-module group and the quad-module group; however, there must be no gaps between quad modules.

BA8-C Expander

Slot	Module	Size	Current		
			+5 V	+15 V	-15 V
1	M8320	Quad			
2	KM8-A	Hex	2.0	0	0
3					
4	MM8-AA or MM8-AB	Double Hex	2.5	0	0
5					
6					
7					
8					
9					
10					
Total Current (1-10)					
Available Current (1-10)			25.0	2.0	2.0
Remaining Current (1-10)					
11					
12					
13					
14					
15					
16					
17					
18					
19					
20	Connector				
Total Current (11-20)					
Available Current (11-20)			25.0	2.0	2.0
Remaining Current (11-20)					

PDP-8/E or PDP-8/M

Slot	Module	Size	Current		
			+5 V	+15 V	-15 V
1	KC8-E	Quad			
2	M8330	Quad	4.5	1.0	0.53
3	M8310	Quad			
4	M8300	Quad			
5					
6					
7					
8					
9					
10					
11					
12					
13					
14					
15					
16					
17					
18					
19					
20	Connector				
Total Current					
Available Current			20.0	2.0	8.0
Remaining Current					

**PDP-8/E OR PDP-8/M + BA8-C
(EXPANDER MOUNTED BELOW
PDP-8/E OR PDP-8/M)**

NOTES

1. Only MM8-E memory can be used in this configuration (i.e., BA8-C mounted below).
2. Total current for KK8-E modules (M8320, M8330, M8310, and M8300) is listed with M8330.
3. If a KM8-E is used instead of a KM8-A, it should be placed in slot 17 of the BA8-C expander (or slot 15 if a KE8-E is in the system).
4. Additional memory units are installed from slot 6 down; the MM8-E cannot be placed in the BA8-C expander.
5. An RFI shield is inserted in the slot immediately following the last memory unit.
6. BC80C cable assemblies connect slot 20 of the PDP-8/E or PDP-8/M and slot 1 of the BA8-C. (The expander must mount below the PDP-8/E or PDP-8/M.)
7. The BA8-C power supply consists of two G8018 regulators; one provides 25 A at +5 Vdc, 2 A at +15 Vdc, and 2 A at -15 Vdc for the top 10 slots while the other provides the same current for the bottom 10 slots. As much as possible, modules should be distributed so that the current drain from each regulator is approximately equal. This means that there can be gaps between hex modules and between the hex-module group and the quad-module group; however, there must be no gaps between quad modules.

PDP-8/E or PDP-8/M

Slot	Module	Size	Current		
			+5 V	+15 V	-15 V
1	KC8-E	Quad			
2	M8320	Quad			
3	MM8-E/EJ	Triple			
4		Quad			
5					
6					
7					
8					
9					
10					
11					
12					
13					
14					
15					
16					
17					
18					
19					
20	Connector				
Total Current					
Available Current			20.0	2.0	8.0
Remaining Current					

BA8-C Expander

Slot	Module	Size	Current		
			+5 V	+15 V	-15 V
1	Connector				
2	KM8-A		2.0	0	0
3					
4					
5					
6					
7					
8					
9					
10					
Total Current (1-10)					
Available Current (1-10)			25.0	2.0	2.0
Remaining Current (1-10)					
11					
12					
13					
14					
15					
16					
17					
18	M8300				
19	M8310				
20	M8330		4.5	1.0	0.53
Total Current (11-20)					
Available Current (11-20)			25.0	2.0	2.0
Remaining Current (11-20)					

NOTES

1. Total current for KK8-E modules (M8320, M8300, M8310, and M8330) is listed with M8330.
2. The KM8-E is required when more than 4K of memory is in the system. If a KM8-A is used instead of a KM8-E, it must be placed in slot 2 or 3 of the H9300.
3. Additional memory units are inserted from slot 6 down. The MM8-E cannot be placed in the H9300.
4. An RFI shield is inserted in the slot immediately following the last memory unit.
5. BC80C cable assemblies connect slot 20 or slot 40 of the PDP-8/E, or slot 20 of the PDP-8/M, to slot 1 of the H9300. (The expander must mount below the PDP-8/E or PDP-8/M.)

PDP-8/E or PDP-8/M With MM8-E Memory

Slot	Module	Size	Current		
			+5 V	+15 V	-15 V
1	KC8-E	Quad			
2	M8320	Quad			
3	MM8-E/EJ	Triple			
4		Quad			
5					
6					
7					
8					
9					
10					
11					
12					
13					
14					
15					
16					
17					
18					
19					
20	Connector				
Total Current					
Available Current			20.0	2.0	8.0
Remaining Current					

H9300 Expander

Slot	Module	Size	Current		
			+5 V	+15 V	-15 V
1	Connector				
2					
3					
4					
5					
6					
7					
8					
9	KM8-E	Quad	1.0	0	0
10	M8300	Quad			
11	M8310	Quad			
12	M8330	Quad	4.5	1.0	0.53
Total Current					
Available Current			25.0	2.0	2.0
Remaining Current					

**PDP-8/E OR PDP-8/M + H9300
(EXPANDER MOUNTED BELOW
PDP-8/E OR PDP-8/M)**

NOTES

1. Total current for KC8-E modules (M8320, M8300, M8310, and M8330) is listed with M8330.
2. If a KM8-E is used instead of a KM8-A, it should be placed in slot 5 of the PDP-8/E or PDP-8/M (or slot 7 if a KE8-E is in the system).
3. An RFI shield is not used in this configuration.
4. If a second memory unit is used, it is inserted in slot 6; a third is inserted in slot 4. The MM8-A cannot be placed in the PDP-8/E or PDP-8/M.
5. Data break device modules cannot be inserted in slot 10 or slot 11 of the H9300 expander.
6. BC80C cable assemblies connect slot 20 of the PDP-8/E or PDP-8/M and slot 1 of the H9300. (The expander must mount below the PDP-8/E or PDP-8/M.)

PDP-8/E or PDP-8/M with MM8-A Memory

Slot	Module	Size	Current		
			+5 V	+15 V	-15 V
1	KC8-E	Quad			
2	M8330	Quad	4.5	1.0	0.53
3	M8310	Quad			
4	M8300	Quad			
5					
6					
7					
8					
9					
10					
11					
12					
13					
14					
15					
16					
17					
18					
19					
20	Connector				
Total Current					
Available Current			20.0	2.0	8.0
Remaining Current					

H9300 Expander

Slot	Module	Size	Current		
			+5 V	+15 V	-15 V
1	Connector				
2	KM8-A	Hex	2.0	0	0
3					
4					
5					
6					
7					
8	MM8-AA	Double	2.5	0	0
9	MM8-AB	Hex			
10					
11					
12	M8320	Quad			
Total Current					
Available Current			25.0	2.0	2.0
Remaining Current					

**PDP-8/E OR PDP-8/M + FPP8-E
(FPP8-E MOUNTED BELOW
PDP-8/E OR PDP-8/M)**

NOTES

1. Total current for KK8-E modules (M8320, M8300, M8310, and M8330) is listed with M8330.
2. If a KM8-E is used instead of a KM8-A, it should be placed in slot 5 of the PDP-8/E or PDP-8/M (or slot 7 if a KE8-E is in the system).
3. If a second memory unit is used (only two memory units are possible), it is placed in slots 6 and 7; the FPP8-A is moved to slots 4 and 5. The MM8-A cannot be placed in the PDP-8/E or PDP-8/M.
4. An RFI shield is not used in this configuration.
5. Data break device modules cannot be inserted in slot 10 or slot 11 of the FPP8-E.
6. BC80C cable assemblies connect slot 20 of the PDP-8/E or PDP-8/M and slot 1 of the FPP8-E. (The FPP8-E must mount below the PDP-8/E or PDP-8/M.)

PDP-8/E or PDP-8/M with MM8-A Memory

Slot	Module	Size	Current		
			+5 V	+15 V	-15 V
1	KC8-E	Quad			
2	M8330	Quad	4.5	1.0	0.53
3	M8310	Quad			
4	M8300	Quad			
5					
6					
7					
8					
9					
10					
11					
12					
13					
14					
15					
16					
17					
18					
19					
20	Connector				
Total Current					
Available Current			20.0	2.0	8.0
Remaining Current					

FPP8-E (H9300 and FPP8-A)

Slot	Module	Size	Current		
			+5 V	+15 V	-15 V
1	Connector				
2	KM8-A	Hex	2.0	0	0
3					
4					
5					
6	FPP8-A	Double	8.8	0	0
7		Hex			
8	MM8-AA	Double	2.5	0	0
9	or MM8-AB	Hex			
10					
11					
12	M8320	Quad			
Total Current					
Available Current			25.0	0	0
Remaining Current					

**PDP-8/E OR PDP-8/M + FPP8-E
(FPP8-E MOUNTED BELOW
PDP-8/E OR PDP-8/M)**

NOTES

1. Total current for KM8-E modules (M8320, M8300, M8310, and M8330) is listed with M8330.
2. If a KM8-A is used instead of a KM8-E, it must be placed in slot 2 or slot 3 of the FPP8-E.
3. Additional memory units are inserted from slot 6 down. The MM8-E cannot be placed in the FPP8-E.
4. An RFI shield is inserted in the slot immediately following the last memory unit.
5. BC80C cable assemblies connect slot 20 of the PDP-8/E or PDP-8/M and slot 1 of the FPP8-E. (The FPP8-E must mount below the PDP-8/E or PDP-8/M.)

PDP-8/E or PDP-8/M with MM8-E Memory

Slot	Module	Size	Current		
			+5 V	+15 V	-15 V
1	KC8-E	Quad			
2	M8320	Quad			
3	MM8-E/EJ	Triple Quad			
4					
5					
6					
7					
8					
9					
10					
11					
12					
13					
14					
15					
16					
17					
18					
19					
20	Connector				
Total Current					
Available Current			20.0	2.0	8.0
Remaining Current					

FPP8-E (H9300 and FPP8-A)

Slot	Module	Size	Current		
			+5 V	+15 V	-15 V
1	Connector				
2					
3					
4	FPP8-A	Double Hex	8.8	0	0
5					
6					
7					
8					
9	KM8-E	Quad	1.0	0	0
10	M8300	Quad			
11	M8310	Quad			
12	M8330	Quad	4.5	1.0	0.53
Total Current					
Available Current			25.0	2.0	2.0
Remaining Current					

**8A600 + BA8-C
(EXPANDER MOUNTED
ABOVE 8A600)**

NOTES

- Total current for KK8-F modules (M8320, M8300, M8310, and M8330) is listed with M8330.
- The BA8-C power supply consists of two G8018 regulators; one provides 25 A at +5 Vdc, 2 A at +15 Vdc, and 2 A at -15 Vdc for the top 10 slots, while the other provides the same current for the bottom 10 slots. As much as possible, modules should be distributed so that the current drain from each regulator is approximately equal. This means that there can be gaps between hex modules and between the hex-module group and the quad-module group; however, there must be no gaps between quad modules.
- If a KM8-E is used instead of a KM8-A, it should be placed in slot 9 of the 8A600 (slot 7 if a KE8-E is in the system).
- If a DKC8-A is used, it should be placed in slot 3 of the 8A600. (The KM8-A and the DKC8-A can be interchanged in slots 2 and 3.)
- MM8-A memory is built from slot 4 to slot 11 of the BA8-C expander. (A memory unit inserted in slot 10 prevents slot 11 from being used.) Data break device modules can be inserted in any slot between the CPU and memory, except slots 2 and 3 of the 8A600, while programmed I/O device modules can be inserted in any slot except 2 and 3 of the 8A600. (If either type module is a hex board, however, there can be no signals on the E connector of the module.

If a KT8-A memory management option is used, the KT8-A module is inserted in the 8A600 chassis (Table 2-1, Note 5), preferably in slot 4, and the KT8-A terminator (M9020) is inserted in an E connector of the BA8-C expander, preferably in slot 4. (The KT8-A and the M9020 are connected by cable 70-11411-1J.) MM8-AB memory is built from slot 5 to slot 11 in the BA8-C. (A memory unit inserted in slot 11 prevents slot 12 from being used.)

With the KT8-A, it is possible to install memory in both boxes of the system. When this happens, slot 4, connector E, of the BA8-C contains the M9020, while slots 5 through 12 are used by memory. In the 8A600, slot 4 contains the KT8-A, while memory is continued from slot 5 toward slot 8. Data break device modules can be inserted in 8A600 slots that are between the CPU and the first memory unit. Programmed I/O device modules can be inserted in any slot except 2 and 3 of the 8A600.

- BC08H cable assemblies connect slot 1 of the 8A600 and slot 20 of the BA8-C. (The expander must mount above the 8A600.)

BA8-C Expander

Slot	Module	Size	Current		
			+5 V	+15 V	-15 V
1	M8320	Quad			
2					
3					
4					
5					
6					
7					
8					
9					
10					
Total Current (1-10)					
Available Current (1-10)			25.0	2.0	2.0
Remaining Current (1-10)					
11					
12					
13					
14					
15					
16					
17					
18					
19					
20	Connector				
Total Current (11-20)					
Available Current (11-20)			25.0	2.0	2.0
Remaining Current (11-20)					

8A600 (H9300 Chassis)

Slot	Module	Size	Current		
			+5 V	+15 V	-15 V
1	Connector				
2	KM8-A	Hex	2.0	0	0
3					
4					
5					
6					
7					
8					
9					
10	M8300	Quad			
11	M8310	Quad			
12	M8330	Quad	4.5	1.0	0.53
If KC8-A is used, add 2.5 A to +5 V.				0	0
Total Current					
Available Current			25.0	2.0	2.0
Remaining Current					

**8A620 OR 8A625+ BA8-C
(EXPANDER MOUNTED
BELOW 8A620 OR 8A625)**

NOTES

- Total current for KK8-F modules (M8320, M8330, M8310, and M8300) is listed with M8330.
- The BA8-C power supply consists of two G8018 regulators; one provides 25 A at +5 Vdc, 2 A at +15 Vdc, and 2 A at -15 Vdc for the top 10 slots, while the other provides the same current for the bottom 10 slots. As much as possible, modules should be distributed so that the current drain from each regulator is approximately equal. This means that there can be gaps between hex modules and between the hex-module group and the quad-module group; however, there must be no gaps between quad modules.
- If a KM8-E is used instead of a KM8-A, it should be placed in slot 17 of the BA8-C expander (slot 15 if a KE8-E is in the system).
- If a DKC8-A is used, it should be placed in slot 3 of the BA8-C expander. (The KM8-A and the DKC8-A can be interchanged in slots 2 and 3.) If the KM8-A is not in the system, put the DKC8-A in slot 2.
- Memory is built from slot 4 to slot 11 of the 8A620 or 8A625. (An MM8-A memory unit inserted in slot 10 prevents slot 11 from being used.) Data break device modules can be inserted in any slot between the CPU and memory, except slots 2 and 3 of the BA8-C expander, while programmed I/O device modules can be inserted in any slot except 2 and 3 of the expander. (If either type module is a hex board, however, there can be no signals on the E connector of the module.)

If a KT8-A memory management option is used, the KT8-A module is inserted in the BA8-C chassis (Table 2-1, Note 5), preferably in slot 4, and the KT8-A terminator (M9020) is inserted in an E connector of the 8A620 or 8A625, preferably in slot 4. (The KT8-A and the M9020 are connected by cable 70-11411-1J.) Memory is built from slot 5 to slot 11 in the 8A620 or 8A625. (An MM8-A memory unit inserted in slot 11 prevents slot 12 from being used.)

With the KT8-A, it is possible to install memory in both boxes of the system. When this happens, slot 4, connector E, of the 8A620 or 8A625 contains the M9020, while slots 5 through 12 are used by memory. In the BA8-C expander, slot 4 contains the KT8-A, while memory is continued from slot 5 toward slot 11. Data break device modules can be inserted in BA8-C expander slots that are between the CPU and the first memory unit. Programmed I/O device modules can be inserted in any slot except 2 and 3 of the expander.

- BC08H cable assemblies connect slot 20 of the 8A620 or 8A625 and slot 1 of the BA8-C expander. (The expander must mount below the 8A620 or 8A625.)

8A620 or 8A625 (BA8-C)

Slot	Module	Size	Current		
			+5 V	+15 V	-15 V
1	M8320	Quad			
2					
3					
4					
5					
6					
7					
8					
9					
10					
If a KC8-A is used, add 2.5 A to +5 V.					
Total Current (1-10)					
Available Current (1-10)			25.0	2.0	2.0
Remaining Current (1-10)					
11					
12					
13					
14					
15					
16					
17					
18					
19					
20	Connector				
Total Current (11-20)					
Available Current (11-20)			25.0	2.0	2.0
Remaining Current (11-20)					

BA8-C Expander

Slot	Module	Size	Current		
			+5 V	+15 V	-15 V
1	Connector				
2	KM8-A	Hex	2.0	0	0
3					
4					
5					
6					
7					
8					
9					
10					
Total Current (1-10)					
Available Current (1-10)			25.0	2.0	2.0
Remaining Current (1-10)					
11					
12					
13					
14					
15					
16					
17					
18	M8300	Quad			
19	M8310	Quad			
20	M8330	Quad	4.5	1.0	0.53
Total Current (11-20)					
Available Current (11-20)			25.0	2.0	2.0
Remaining Current (11-20)					

**8A620 OR 8A625 + BA8-C
(EXPANDER MOUNTED
ABOVE 8A620 OR 8A625)**

NOTES

1. Total current for KK8-F modules (M8320, M8300, M8310, M8330) is listed with M8330.
2. The BA8-C power supply consists of two G8018 regulators; one provides 25 A at +5 Vdc, 2 A at +15 Vdc, and 2 A at -15 Vdc for the top 10 slots, while the other provides the same current for the bottom 10 slots. As much as possible, modules should be distributed so that the current drain from each regulator is approximately equal. This means that there can be gaps between hex modules and between the hex-module group and the quad-module group; however, there must be no gaps between quad modules.
3. If a KM8-E is used instead of a KM8-A, it should be placed in slot 17 of the 8A620 or 8A625 (slot 15 if a KE8-E is in the system).
4. If a DKC8-A is used, it should be placed in slot 3 of the 8A620 or 8A625. (The KM8-A and the DKC8-A can be interchanged in slots 2 and 3.) If the KM8-A is not in the system, put the DKC8-A in slot 2.
5. Memory is built from slot 4 to slot 11 of the BA8-C expander. (An MM8-A memory unit inserted in slot 10 prevents slot 11 from being used.) Data break device modules can be inserted in any slot between the CPU and memory, except slots 2 and 3 of the 8A620 or 8A625, while programmed I/O device modules can be inserted in any slot except 2 and 3 of the 8A620 or 8A625. (If either type module is a hex board, however, there can be no signals on the E connector of the module.)

If a KT8-A memory management option is used, the KT8-A module is inserted in the 8A620 or 8A625 chassis (Table 2-1, Note 5), preferably in slot 4, and the KT8-A terminator (M9020) is inserted in an E connector of the BA8-C expander, preferably in slot 4. (The KT8-A and the M9020 are connected by cable 70-11411-1J.) Memory is built from slot 5 to slot 11 in the BA8-C. (A memory unit inserted in slot 11 prevents slot 12 from being used.)

With the KT8-A, it is possible to install memory in both boxes of the system. When this happens, slot 4, connector E, of the BA8-C contains the M9020, while slots 5 through 12 are used by memory. In the 8A620 or 8A625, slot 4 contains the KT8-A, while memory is continued from slot 5 toward slot 11. Data break device modules can be inserted in 8A620 or 8A625 slots that are between the CPU and the first memory unit. Programmed I/O device modules can be inserted in any slot except 2 and 3 of the 8A620 or 8A625.

6. BC08H cable assemblies connect slot 1 of the 8A620 or 8A625 and slot 20 of the BA8-C expander. (The expander must mount above the 8A620 or 8A625.)

BA8-C Expander

Slot	Module	Size	Current		
			+5 V	+15 V	-15 V
1	M8320	Quad			
2					
3					
4					
5					
6					
7					
8					
9					
10					
Total Current (1-10)					
Available Current (1-10)			25.0	2.0	2.0
Remaining Current (1-10)					
11					
12					
13					
14					
15					
16					
17					
18					
19					
20	Connector				
Total Current (11-20)					
Available Current (11-20)			25.0	2.0	2.0
Remaining Current (11-20)					

8A620 or 8A625 (BA8-C)

Slot	Module	Size	Current		
			+5 V	+15 V	-15 V
1	Connector				
2	KM8-A	Hex	2.0	0	0
3					
4					
5					
6					
7					
8					
9					
10					
If KC8-A is used, add 2.5 A to +5 V.				0	0
Total Current (1-10)					
Available Current (1-10)			25.0	2.0	2.0
Remaining Current (1-10)					
11					
12					
13					
14					
15					
16					
17					
18	M8300	Quad			
19	M8310	Quad			
20	M8330	Quad	4.5	1.0	0.53
Total Current (11-20)					
Available Current (11-20)			25.0	2.0	2.0
Remaining Current (11-20)					

**8A620 OR 8A625 + H9300
(EXPANDER MOUNTED
BELOW 8A620 OR 8A625)**

NOTES

- Total current for KK8-F modules (M8320, M8300, M8310, and M8330) is listed with M8330.
- The BA8-C power supply consists of two G8018 regulators; one provides 25 A at +5 Vdc, 2 A at +15 Vdc, and 2 A at -15 Vdc for the top 10 slots, while the other provides the same current for the bottom 10 slots. As much as possible, modules should be distributed so that the current drain from each regulator is approximately equal. This means that there can be gaps between hex modules and between the hex-module group and the quad-module group; however, there must be no gaps between quad modules.
- If a KM8-E is used instead of a KM8-A, it should be placed in slot 9 of the H9300 expander (slot 7 if a KE8-E is in the system).
- If a DKC8-A is used, it should be placed in slot 3 of the H9300 expander. (The KM8-A and the DKC8-A can be interchanged in slots 2 and 3.) If the KM8-A is not in the system, put the DKC8-A in slot 2.
- Memory is built from slot 4 to slot 11 of the 8A620 or 8A625. (An MM8-A memory unit inserted in slot 10 prevents slot 11 from being used.) Data break device modules can be inserted in any slot between the CPU and memory, except slots 2 and 3 of the H9300 expander, while programmed I/O device modules can be inserted in any slot except 2 and 3 of the expander. (If either type module is a hex board, however, there can be no signals on the E connector of the module.)

If a KT8-A memory management option is used, the KT8-A module is inserted in the H9300 chassis (Table 2-1, Note 5), preferably in slot 4, and the KT8-A terminator (M9020) is inserted in an E connector of the 8A620 or 8A625, preferably in slot 4. (The KT8-A and the M9020 are connected by cable 70-11411-1J.) Memory is built from slot 5 to slot 11 in the 8A620 or 8A625. (An MM8-A memory unit inserted in slot 11 prevents slot 12 from being used.)

With the KT8-A, it is possible to install memory in both boxes of the system. When this happens, slot 4, connector E, of the 8A620 or 8A625 contains the M9020, while slots 5 through 12 are used by memory. In the H9300 expander, slot 4 contains the KT8-A, while memory is continued from slot 5 toward slot 8. Data break device modules can be inserted in H9300 expander slots that are between the CPU and the first memory unit. Programmed I/O device modules can be inserted in any slot except 2 and 3 of the expander.

- BC08H cable assemblies connect slot 1 of the H9300 expander and slot 20 of the 8A620 or 8A625. (The expander must mount below the 8A620 or 8A625.)

8A620 or 8A625 (BA8-C)

Slot	Module	Size	Current		
			+5 V	+15 V	-15 V
1	M8320	Quad			
2					
3					
4					
5					
6					
7					
8					
9					
10					
	If KC8-A is used, add 2.5 A to +5 V.			0	0
Total Current (1-10)					
Available Current (1-10)			25.0	0	0
Remaining Current (1-10)					
11					
12					
13					
14					
15					
16					
17					
18					
19					
20	Connector				
Total Current (11-20)					
Available Current (11-20)			25.0	2.0	2.0
Remaining Current (11-20)					

H9300 Expander

Slot	Module	Size	Current		
			+5 V	+15 V	-15 V
1	Connector				
2	KM8-A	Hex	2.0	0	0
3					
4					
5					
6					
7					
8					
9					
10	M8300	Quad			
11	M8310	Quad			
12	M8330	Quad	4.5	1.0	0.53
Total Current					
Available Current			25.0	2.0	2.0
Remaining Current					