

TITLE	SIZE	CODE	NUMBER	REV
DWB-E	SHEET 2 OF 5	B DD	DWB-E	[]

CUSTOMER PRINT SET						ELECTRICAL						CUSTOMER PRINT SET						ELECTRICAL					
MFG. SET		FIND NO.	DRAWING NO.	REV	NO OF SHT	DESCRIPTION	OPTION NO./FILE DATE	MFG. SET		FIND NO.	DRAWING NO.	REV	NO OF SHT	DESCRIPTION	OPTION NO./FILE DATE								
X		1	D-UA-DW8-E-Ø	B	3	UNIT ASSY (DW8-E)		X		5	D-CS-M71Ø2-Ø-1	#	2	POSITIVE I/O BUS CONVERTER									
X			D-MU-DW8-E-1	A	1	MODULE UTILIZATION					K-CO-M71Ø2-Ø-4		1	X-Y COORDINATE HOLE LOCATION									
X			A-PL-DW8-E-1	A	1	MODULE UTILIZATION (PL)					D-AH-M71Ø2-Ø-5		1	ASSY DRILLING HOLE LOCATION									
X			D-BS-DW8-E-3	A	1	DW8-E CONTROL					B-MH-M71Ø2-Ø-6		1	MODULE ECO HISTORY									
X			D-BS-DW8-E-4	B	2	I/O BUS CONVERTER																	
X			D-IC-DW8-E-5	E	1	I/O BUS CONVERTER SIGNALS																	
X			D-BS-DW8-E-6	A	1	DW8-E EXPANDER CONTROL		X		6	D-CS-M71Ø3-Ø-1	#	1	NEGATIVE I/O BUS CONVERTER									
X			D-BS-DW8-E-7	E	2	I/O BUS EXPANDER					K-CO-M71Ø3-Ø-4		1	X-Y COORDINATE HOLE LOCATION									
X			D-IC-DW8-E-8	E	1	I/O BUS EXPANDER SIGNALS					D-AH-M71Ø3-Ø-5		1	ASSY DRILLING HOLE LOCATION									
			D-IA-7009155-0-0		1	HARNESS AC					B-MH-M71Ø3-Ø-6		1	MODULE ECO HISTORY									
			D-IA-7009288-0-0		1	HARNESS DC																	
X			A-SP-DW8-E-12	A	19	DW8-E ENGINEERING SPEC																	
			A-SP-DW8-E-13	*	1	DW8E ACCEPTANCE PROCEDURE		X		7	E-CS-M832Ø-Ø-1	#	2	BUS LOADS									
X			A-AL-DW8-E-1Ø	A	1	DW8-E ACCESSORY LIST					K-CO-M832Ø-Ø-4		1	X-Y COORDINATE HOLE LOCATION									
X			D-IC-DW8-E-?	A	2	I/O CONNECTORS					D-AH-M832Ø-Ø-5		1	ASSY DRILLING HOLE LOCATION									
X			A-SP-DW8-E-9	*		FIELD INSTALLATION & ACCEPTANCE					B-MH-M832Ø-Ø-6		1	MODULE ECO HISTORY									
								X		8	D-AD-7009287-0-0	#	1	POWER SUPPLY									
											D-IA-7409376-0-0		2	CHASSIS (P.S.)									
X		2	D-AD-7009154-0-C	*	1	WIRED ASSY		X		9	E-IA-5409728-0-0	#	1	REGULATOR BD ASSY									
			A-PL-7009154-0-0		2	WIRED ASSY (PL)		X			D-CS-5409728-0-1	#	1	REGULATOR BD									
X			K-WL-DW8-E-11	B	1	WIRE LIST					K-CO-5409728-0-4		1	X-Y COORDINATE HOLE LOCATION									
			C-MD-7409056-0-0		1	OMNICASTING (BM8-L)					D-AH-5409728-0-5		1	ASSY DRILLING HOLE LOCATION									
			E-SC-1205348-0-0		1	288 PIN CONNECTOR BLOCK (H803)					B-MH-5409728-0-6		1	MODULE ECO HISTORY									
											C-IA-7409375-0-0		1	BRK SUPPORT ETCH BD									
								X		10	C-UA-BCØ5H-Ø-Ø	#	1	LINE SET 115V AC 7 AMP									
		3	D-IA-5409396-0-0		1	8/E POWER BUS BOARD				11	D-UA-H4ØØ-Ø-Ø		1	AC INPUT BOX ASSY (H4ØØ-A)									
			B-CS-5409396-0-1		1	CIRCUIT SCHEMATIC					A-PL-H4ØØ-Ø-Ø		1	AC INPUT BOX ASSY (H4ØØ-A) (PL)									
			K-CO-5409396-0-4		1	X-Y COORDINATE HOLE LOCATION					D-IA-5309845-0-0		1	BOX AC INPUT									
			D-AH-5409396-0-5		1	ASSY DRILLING HOLE LOCATION					C-MD-5309849-0-0		1	COVER									
			B-MH-5409396-0-6		1	MODULE ECO HISTORY					A-DC-5309899-0-0		1	POWER CTRL DECAL 115V									
			D-IA-5009395-0-0		1	ETCH BOARD 8/E					C-IA-5409824-0-0		1	POWER CTRL BOARD 115V									
X		4	D-CS-M71Ø1-Ø-1	#	2	CONTROL					D-AH-5409824-0-5		1	ASSY DRILLING HOLE LOCATION									
			K-CO-M71Ø1-Ø-4		1	X-Y COORDINATE HOLE LOCATION					B-MH-5409824-0-6		1	MODULE ECO HISTORY									
			D-AI-M71Ø1-Ø-5		1	ASSY DRILLING HOLE LOCATION																	
			B-MH-M71Ø1-Ø-6		1	MODULE ECO HISTORY																	

CUSTOMER PRINT SET CODES
X = PRINT OF DOCUMENT INCLUDED IN PRINT SET
C = INCLUDES ALL PRINTS INDICATED ON DOCUMENT
S = CONFIDENTIAL AUTHORIZED SIGNATURE REQUIRED

TITLE
DW8-E
SHEET 3 OF 5
SIZE CODE B DD
NUMBER DW8-E
REV D

CUSTOMER PRINT SET		ELECTRICAL					CUSTOMER PRINT SET										
		MFG. SET	FIND NO.	DRAWING NO.	REV	NO OF SHT	DESCRIPTION	OPTION NO./FILE DATE			MFG. SET	FIND NO.	DRAWING NO.	REV	NO OF SHT	DESCRIPTION	OPTION NO./FILE DATE
X			12	C-UA-BC05J-0-0	#	1	LINE SET 230V AC 4 AMP										
			13	D-UA-H400-0-0		1	AC INPUT BOX ASSY (H400-B)										
				A-PL-H400-0-0		1	AC INPUT BOX ASSY (H400-B)(PL)										
				D-IA-5309845-0-0		1	BOX AC INPUT										
				C-MD-5309849-0-0		1	COVER										
				A-DC-5309900-0-0		1	PWR CTRL DECAL 230V										
				C-IA-5409825-0-0		1	PWR CTRL BOARD 230V										
				D-AH-5409825-0-5		1	ASSY DRILLING HOLE LOCATION										
				B-MH-5409825-0-6		1	MODULE ECO HISTORY										
CUSTOMER PRINT SET CODES		X = PRINT OF DOCUMENT INCLUDED IN PRINT SET C = INCLUDES ALL PRINTS INDICATED ON DOCUMENT S = CONFIDENTIAL AUTHORIZED SIGNATURE REQUIRED						TITLE		SHEET 4 OF 5		SIZE CODE		NUMBER		REV	
								DW8-E		B DD		DW8-E		D			

CUSTOMER PRINT SET		MECHANICAL					CUSTOMER PRINT SET		MECHANICAL									
	MFG. SET	FIND NO.	DRAWING NO.	REV	NO OF SHT	DESCRIPTION	OPTION NO./FILE DATE		MFG. SET	FIND NO.	DRAWING NO.	REV	NO OF SHT	DESCRIPTION	OPTION NO./FILE DATE			
		1	D-UA-DW8-E-0	B	3	UNIT ASSY (DW8-E)				8	D-AD-7009287-0-0	tt	1	POWER SUPPLY				
			D-IA-7009155-0-0		1	HARNESS AC					D-IA-7409376-0-0		2	CHASSIS (P.S.)				
			D-IA-7009288-0-0		1	HARNESS DC												
			E-IA-7410650-0-0		2	CHASSIS												
		2	D-AD-7009154-0-0	*	1	WIRED ASSY				9	E-IA-5409728-0-0	#	1	REGULATOR BD ASSY				
			A-PL-7009154-0-0		2	WIRED ASSY (PL)					D-CS-5409728-0-1	#	1	REGULATOR BD				
			C-MD-7409056-0-0		1	OMNICASTING (BM8-L)					K-CO-5409728-0-4		1	X-Y COORDINATE HOLE LOCATION				
			E-SC-1205348-0-0		1	288 PIN CONNECTOR BLOCK (H803)					D-AH-5409728-0-5		1	ASSY DRILLING HOLE LOCATION				
		3	D-IA-5409396-0-0		1	8/E POWER BUS BOARD					B-MH-5409728-0-6		1	MODULE ECO HISTORY				
			B-CS-5409396-0-1		1	CIRCUIT SCHEMATIC					C-IA-7409375-0-0		1	BRKT SUPPORT ETCH BD				
			K-CO-5409356-0-4		1	X-Y COORDINATE HOLE LOCATION				10	C-UA-BC05H-0-0	#	1	LINE SET 115V AC 7 AMP				
			D-AH-5409396-0-5		1	ASSY DRILLING HOLE LOCATION												
			B-MH-5409396-0-6		1	MODULE ECO HISTORY												
			D-IA-5009395-0-0		1	ETCH BOARD 8/E												
		4	D-CS-M7101-0-1	#	2	CONTROL				11	D-UA-H400-0-0		1	AC INPUT BOX ASSY (H400-A)				
			K-CO-M7101-0-4		1	X-Y COORDINATE HOLE LOCATION					A-PL-H400-0-0		1	AC INPUT BOX ASSY (H400-A) PL				
			D-AH-M7101-0-5		1	ASSY DRILLING HOLE LOCATION					D-IA-5309845-0-0		1	BOX AC INPUT				
			B-MH-M7101-0-6		1	MODULE ECO HISTORY					C-MD-5309849-0-0		1	COVER				
		5	D-CS-M7102-0-1	#	2	POSITIVE I/O BUS CONVERTER					A-DC-5309899-0-0		1	PWR CTRL DECAL 115V				
			K-CO-M7102-0-4		1	X-Y COORDINATE HOLE LOCATION					C-IA-5409824-0-0		1	POWER CTRL BOARD 115V				
			D-AH-M7102-0-5		1	ASSY DRILLING HOLE LOCATION					D-AH-5409824-0-5		1	ASSY DRILLING HOLE LOCATION				
			B-MH-M7102-0-6		1	MODULE ECO HISTORY					B-MH-5409824-0-6		1	MODULE ECO HISTORY				
		6	D-CS-M7103-0-1	#	2	NEGATIVE I/O BUS CONVERTER				12	C-UA-BC05J-0-0	#	1	LINE SET 230V AC 4 AMP				
			K-CO-M7103-0-4		1	X-Y COORDINATE HOLE LOCATION												
			D-AH-M7103-0-5		1	ASSY DRILLING HOLE LOCATION												
			B-MH-M7103-0-6		1	MODULE ECO HISTORY												
		7	D-CS-M8320-0-1	#	2	BUS LOADS				13	D-UA-H400-0-0		1	AC INPUT BOX ASSY (H400B)				
			K-CO-M8320-0-4		1	X-Y COORDINATE HOLE LOCATION					A-PL-H400-0-0		1	AC INPUT BOX ASSY (H400-B) (PL)				
			D-AH-M8320-0-5		1	ASSY DRILLING HOLE LOCATION					D-IA-5309845-0-0		1	BOX AC INPUT				
			B-MH-M8320-0-6		1	MODULE ECO HISTORY					C-MD-5309849-0-0		1	COVER				
											A-DC-5309900-0-0		1	PWR CTRL DECAL 230V				
											C-IA-5409825-0-0		1	PWR CTRL BOARD 230V				
											D-AH-5409825-0-5		1	ASSY DRILLING HOLE LOCATION				
											B-MH-5409825-0-6		1	MODULE ECO HISTORY				
CUSTOMER PRINT SET CODES		X = PRINT OF DOCUMENT INCLUDED IN PRINT SET C = INCLUDES ALL PRINTS INDICATED ON DOCUMENT S = CONFIDENTIAL AUTHORIZED SIGNATURE REQUIRED					TITLE							SIZE	CODE	NUMBER	REV	
							DW8-E							SHEET 5 OF 5	B	DD	DW8-E	D

This drawing and specifications, herein, are the property of Digital Equipment Corporation and shall not be reproduced or copied or used in whole or in part as the basis for the manufacture or sale of items without written permission.

DIGITAL EQUIPMENT CORPORATION
MAYNARD, MASSACHUSETTS

ENGINEERING SPECIFICATION DATE 1-26-73

TITLE DW8E FIELD INSTALLATION AND ACCEPTANCE PROCEDURE

REVISIONS

REV	DESCRIPTION	CHG NO	ORIG	DATE	APPD BY	DATE

ENG <i>[Signature]</i>	APPD <i>[Signature]</i>	SIZE A	CODE SP	NUMBER DWS-E-9	REV
---------------------------	----------------------------	------------------	------------	-------------------	-----

ENGINEERING SPECIFICATION CONTINUATION SHEET

TITLE DW8E FIELD INSTALLATION AND ACCEPTANCE PROCEDURE

1. HARDWARE

1.1 Basic Configurations

- DW8E-NA Neg. I/O Bus, 115 VAC, 50/60Hz
- DW8E-NB Neg. I/O Bus, 230 VAC, 50/60Hz
- DW8E-PA Pos. I/O Bus, 115 VAC, 50/60 Hz
- DW8E-PB Pos. I/O Bus, 230 VAC, 50/60 Hz

1.2 DW8E Expanders

- DW8E-NX Neg. I/O Bus Expander Modules
Used on DW8E-NA or NB
- DW8E-PX Pos. I/O Bus Expander Modules
Used on DW8E-PA or PB

1.3 Required Cables

- 1.3.1 BC08B-7's are to be used on a positive bus; DM04, PDP-8L, or PDP-12.
- 1.3.2 BC08D-7's are to be used on a negative bus; DM01, PDP-8, PDP-8I, or Linc-8.
- 1.3.3 The PDP-8I can be positive or negative bus but requires BC08D cables. When a DM04 is installed on a positive bus PDP-8I, BC08B cables are required.

1.4 System Requirements

- 1.4.1 The processor must have at least 4K of Read/Write memory.
- 1.4.2 An ASR33 teletype, or equivalent.

1.5 Tools Required

- 1.5.1 Special tools are not required to install a DW8E, all tools necessary are included in the Field Service Tool Kit.
- 1.5.2 If the DW8E is mounted in a cabinet, pallet handling equipment may be necessary to position the cabinet in the final installation position.

	SIZE A	CODE SP	NUMBER DW8-E-9	REV
--	------------------	------------	-------------------	-----

TITLE DW8E FIELD INSTALLATION AND ACCEPTANCE PROCEDURE

2. UNPACKING AND INSTALLING THE DW8E

- 2.1 Inventory all items on the DW8E Accessory List (A-AL-DW8-E-10)
- 2.2 If the DW8E is packed in a separate container, remove it from the shipping container and install it in the appropriate cabinet using the rotating slides included.
- 2.3 Remove the top cover of the DW8E and ensure that all modules are installed in the proper locations according to the module utilization drawing (D-MU-DW8-E-1).
- 2.4 Install the I/O, and Data Break cables using the following table:

BC08 Cables

	BAC	BMB	AC IN	DATA ADDR	DATA
DW8-E	C20	C19	C18	C17 D17*	C16 D16*
	↓	↓	↓	↓ ↓	↓ ↓
DM04	B01	B02	B03	B06 B07	B08 B09
PDP-8L	D36	D35	D34	C36	C35
PDP-12	N14	N15	N16	N17	N18

(*D17 & D16 are expander section Data Break Slots)

BC08D Cables

	BAC	BMB	AC IN	DATA ADDR	DATA
DW8E	C20	C19	C18	C17 D17*	C16 D16*
	↓ ↓	↓ ↓	↓ ↓	↓ ↓ ↓ ↓	↓ ↓ ↓ ↓ ↓ ↓ ↓ ↓
DM01	D01 D02,	D03 D04,	D05, D06,	D07 D08, D12	D13, D09 D10, D14 D15
PDP-8	ME34 MF34,	ME35 MF35,	PE02 PF02,	PE03 PF03,	PE04 PF04,
PDP-8I	J01 J02	J03 J04	J05 J06	J07 J08	J09 J10
*Linc8	A36 A35,	A34 A33,	A32, A31,	A30 A29,	A28 A27,

*Data Terminal Panel

TITLE DW8E FIELD INSTALLATION AND ACCEPTANCE PROCEDURE

2.5 Install the option(s) in the DW8E using;

- A. Module Utilization (D-MU-DW8-E-1)
- B. The options installation and acceptance procedure.
- C. The interface section of the DW8E Engineering Specifications

2.6 With the power source OFF, plug the DW8E power cord into a switched AC power source which is controlled by the C.P.U.'s On-Off switch.

3. ACCEPTANCE

3.1 After all other system acceptance tests are completed, perform the acceptance tests for the option(s) plugged into the DW8E.

3.2 Record any discrepancies on the Acceptance Form.

DIGITAL EQUIPMENT CORPORATION
MAYNARD, MASSACHUSETTS

ACCESSORY LIST

MADE BY <i>Ed Reed</i>	CHECKED <i>V. Quinn</i>	SECTION
DATE 3-27-73	DATE 3-27-73	
ENG Ed Reed	PROD R. Pooler	ISSUED SECT.
DATE 3-27-73	DATE 3-27-73	

LEGEND
D DOCUMENT
DN DOCUMENT CHANGE NOTICE
PA PAPER TAPE ASCII
PB PAPER TAPE BINARY
PM PAPER TAPE READ-IN-MODE

QUANTITY / VARIATION

ITEM NO.	DWG NO. / PART NO.	DESCRIPTION	QUANTITY / VARIATION						KIT CHECK	BY	DATE	INSTALLATION CHECK	BY	DATE
			DW8E-NA	DW8E-NB	DW8E-NX	DW8F-PA	DW8E-PB	DW8E-PX						
1	D-UA-DW8-E-0	DW8-E Assembly	1	1		1	1							
2	C-UA-BC05H-0-0	H400A lineset, 115VAC, 7 amp	1			1								
3	C-UA-BC05J-0-0	H400B lineset, 230VAC, 4 amp		1			1							
4	B-DD-DW8-E	DW8-E print set	1	1		1	1							
5	D-CS-M7101-0-1	M7101 control card	1	1	1	1	1	1						
6	D-CS-M7102-0-1	M7102 Pos. I/O bus converter				4	4	4						
7	D-CS-M7103-0-1	M7103 neg. I/O bus converter	4	4	4									
8	D-CS-M8320-0-1	M8320 bus loads card	1	1	1	1	1	1						
9	D-MD-7409100-1-0	slides, chassis, rotating set	1	1		1	1							
10	BC08B-7	cable, flat black coax				*	*							
11	BC08D-7	Y-cable, flat black coax	*	*										
12	ECO#8M-00007	ECO to PDP-8 send only FOR PDP-8 INSTALLATION	1	1										
13	ECO#LINC8M-00008	ECO TO LINC-8 SEND ONLY FOR LINC-8 INSTALLATION	1	1										
NOTE: BC08B-7 cables are used with positive bus systems - DM04, PDP8L, PDP12.														
BC08D-7 cables are used with negative bus systems - DM01, PDP8, PDP8I, LINC8.														
(CAUTION: A PDP8I can be positive or negative bus but requires BC08D cables.														
When a DM04 is installed on a Positive bus PDP8I, BC08B cables are required.)														

TITLE ACCESSORY LIST	ASSY. NO. D-UA-DW8-E-0	SIZE CODE A AL	NUMBER DW8-E-10	REV. A	ECO NO DW8E-00003
	SHEET 1 OF 1	DIST.			

This drawing and specifications herein are the property of Digital Equipment Corporation and shall not be reproduced or copied or used in whole or in part as the basis for the manufacture or sale of items without written permission. COPYRIGHT © 1973
DIGITAL EQUIPMENT CORPORATION

LEGEND	
NUMBER	VARIATION
DWB-E-NA	NEGATIVE BUS, 115 VAC
DWB-E-NB	NEGATIVE BUS, 230 VAC
DWB-E-NX	NEGATIVE BUS, EXPANDER; M7101, 4-M7103'S, M8320 ADDED TO NA OR NB
DWB-E-PA	POSITIVE BUS, 115 VAC
DWB-E-PB	POSITIVE BUS, 230 VAC
DWB-E-PX	POSITIVE BUS, EXPANDER; M7101, 4-M7102'S, M8320 ADDED TO PA OR PB

NOTES:
1. MOUNTING HARDWARE VARIATION FOR ITEM 16 (FAN) ARE AS FOLLOWS

ITEM #16 (FAN)	MOUNTING HARDWARE	
	ITEM NO.	DISCRIPTION
1205033-1	34	MOUNTING CLIP
ROTRON	5	#6-32X.56 SCREW
1205033-2	35	#8-32 X .38
I M C		SELF TAPPING SCR.

2. ITEM 15 #36, SIDE FILTER, IS TO BE MOUNTED INSIDE BOX.
3. ASSEMBLE AS SHOWN TO PROVIDE SHIPPING TIE-DOWN AND SLIDE-LOCK RELEASE.

QTY.	DESCRIPTION	PART NO.	ITEM NO.
4	#10 WASHER, STEEL, FLAT	9006664	40
2	TIE WRAP	9007033	39
2	KEPNUTS #10-32	9006565	38
2	SCR, PTH #10-32X7/16"	9006072-3	37
A/R	A/R LOOP TAPE, 5/8", VELCRO 0110	9008875-02	36
8	#8-32X.38 LG SELF TAPPING SCREW	9006121	35
8	MTG CLIP	9008202	34
1	STRAIN RELIEF	9008442	33
1	BUS LOADS	D-CS-M8320-01	32
1	NEG I/O BUS CONV.	D-CS-M7103-0-1	31
4	POS I/O BUS CONV.	D-CS-M7102-0-1	30
1	CONTROL	D-CS-M7101-0-1	29
1	HARNESS, DC	D-IA-7009288-00	28
1	HARNESS, A.C.	D-IA-7009155-00	27
4	BUMPER, RUBBER	9008525	26
8	SCR PHIL HD PAN #8-32X.50	9006037-1	25
1	PROTECTION PLATE	B-MD-7409025-00	24
1	STRAIN RELIEF, CABLE	D-IA-7409387-00	23
A/R	A/R GROMMET, NYLON G52A	9008291	22
1	DWB-E WIRED ASSY	D-AD-7009134-00	21
1	POWER SUPPLY ASSY	D-AD-7009287-00	20
1	LINE SET 230V 5 AMP	D-UA-8085J-0-0	19
1	LINE SET 115V 7 AMP	D-UA-8085H-0-0	18
1	BRKT, CABLE TROUGH	D-IA-7409419-00	17
2	FAN, BOXER	1805033	16
1	FILTER, SIDE	D-IA-7409424-0-0	15
1	COVER STRIP	B-MD-7409418-00	14
12	WASHER, INT TOOTH LOCK #6	9006634	13
4	SCR, PHIL HD PAN #6-32X.25	9006035-1	12
2	PANEL, FRONT	1209278-02	11
1	BEZEL	1210065	10
1	COVER	D-IA-7409380-00	9
10	WASHER, EXT TOOTH LOCK #6	9007649	8
11	SCR, PHIL HD PAN #6-32X.25	9006020-1	7
8	NUT KEPS #6-32X5/16X5/32	9006560	6
11	SCR, SLOT HD, BIND #6-32X.56	9007793-4	5
4	WASHER, INT TOOTH LOCK #10	9006636	4
4	SCR, PHL HD TRUSS #10-32X.38	9006071-3	3
1	SLIDE, CHASSIS	D-MD-7409100-10	2
1	CHASSIS, DWB-E	E-IA-7410650-00	1

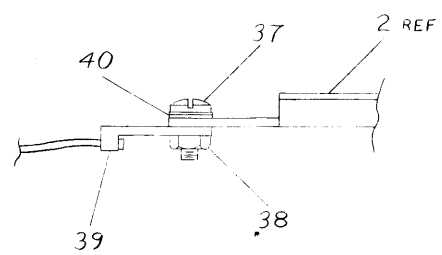
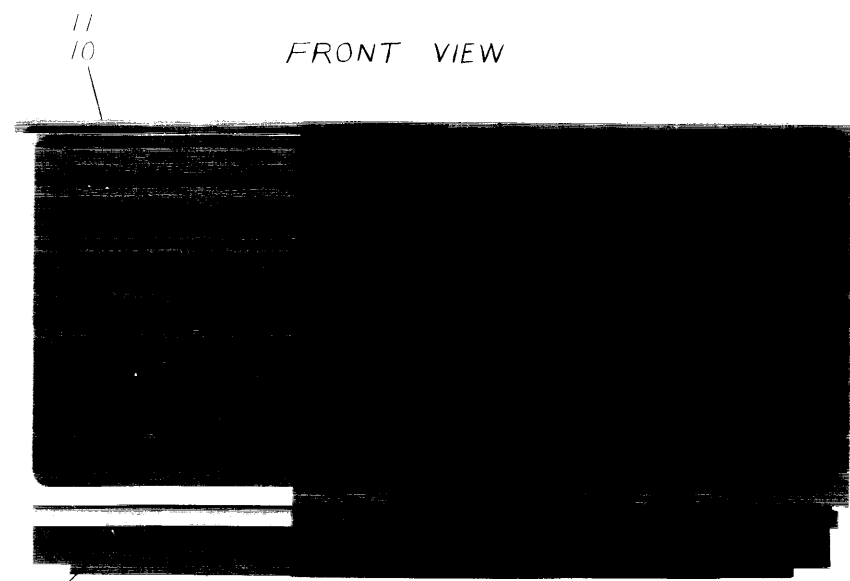
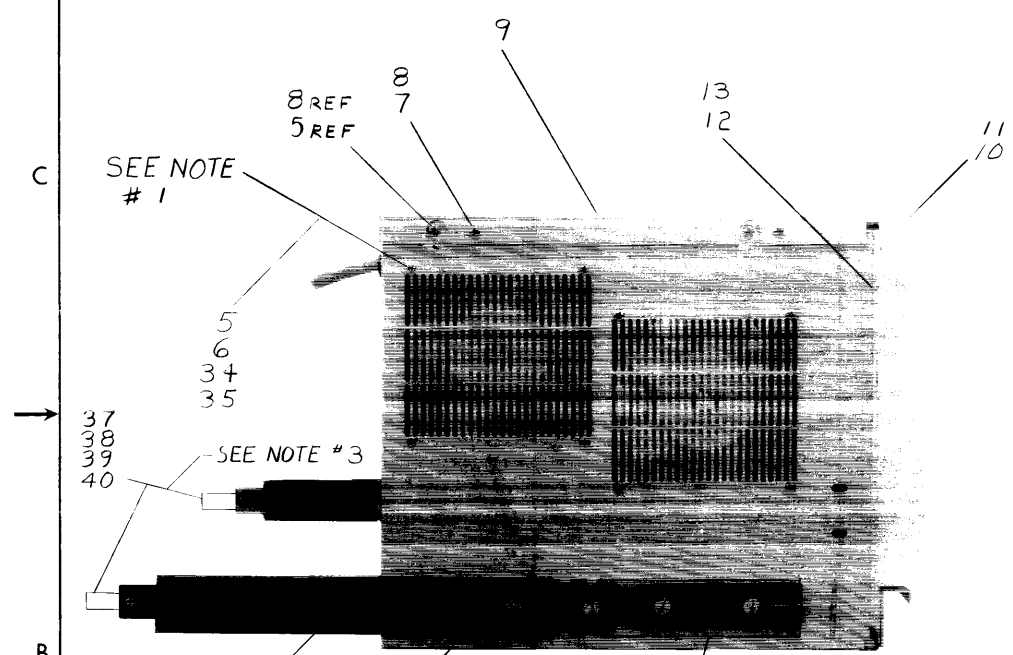

DETAIL B-B
SCALE: NONE

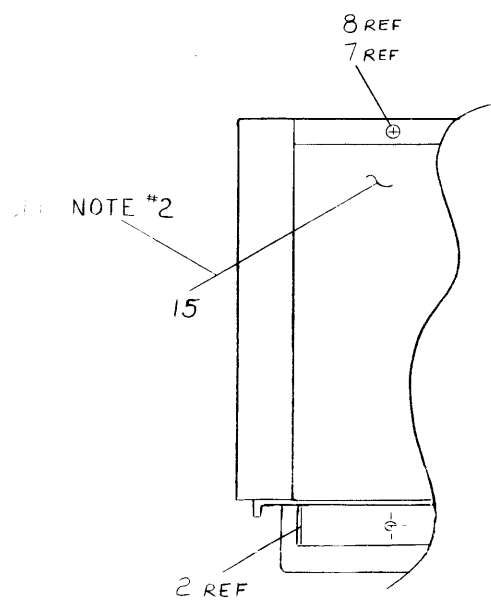

VIEW A-A
SCALE: NONE

REV.	NO.	DATE	BY	CHKD.	APP'D.
A	1	6-17-73	ED REED		
B	2	6-17-73	ED REED		

FIRST USED ON OPTION/MODEL	QTY.	DESCRIPTION	PART NO.	ITEM NO.
DWB-E				

UNLESS OTHERWISE SPECIFIED DIMENSION IN INCHES TOLERANCES	DRN 2/19/73 DATE	DATE 3/6/73	digital EQUIPMENT CORPORATION MAYNARD MASSACHUSETTS	
DECIMALS ANGLES	ENG.	DATE	TITLE	
XXX .005 XX .02 X .05	±0°30'	DATE	UNIT ASSY DWB-E	
REMOVE BURRS AND BREAK SHARP CORNERS SURFACE QUALITY	PROJ. ENG.	DATE	SCALE	
	PROD.	DATE	DUA DWB-E-Ø	
MATERIAL	NEXT HIGHER ASSY	SCALE	NUMBER	REV
	B-DD-DWB-E		DUA DWB-E-Ø	3
FINISH		SHEET	OF	
		3		

This drawing and specifications herein are the property of Digital Equipment Corporation and shall not be reproduced or copied or used in whole or in part as the basis for the manufacture or sale of items without written permission. © D E C 1973
 DIGITAL EQUIPMENT CORPORATION

D
C
B
A

D
C
B
A

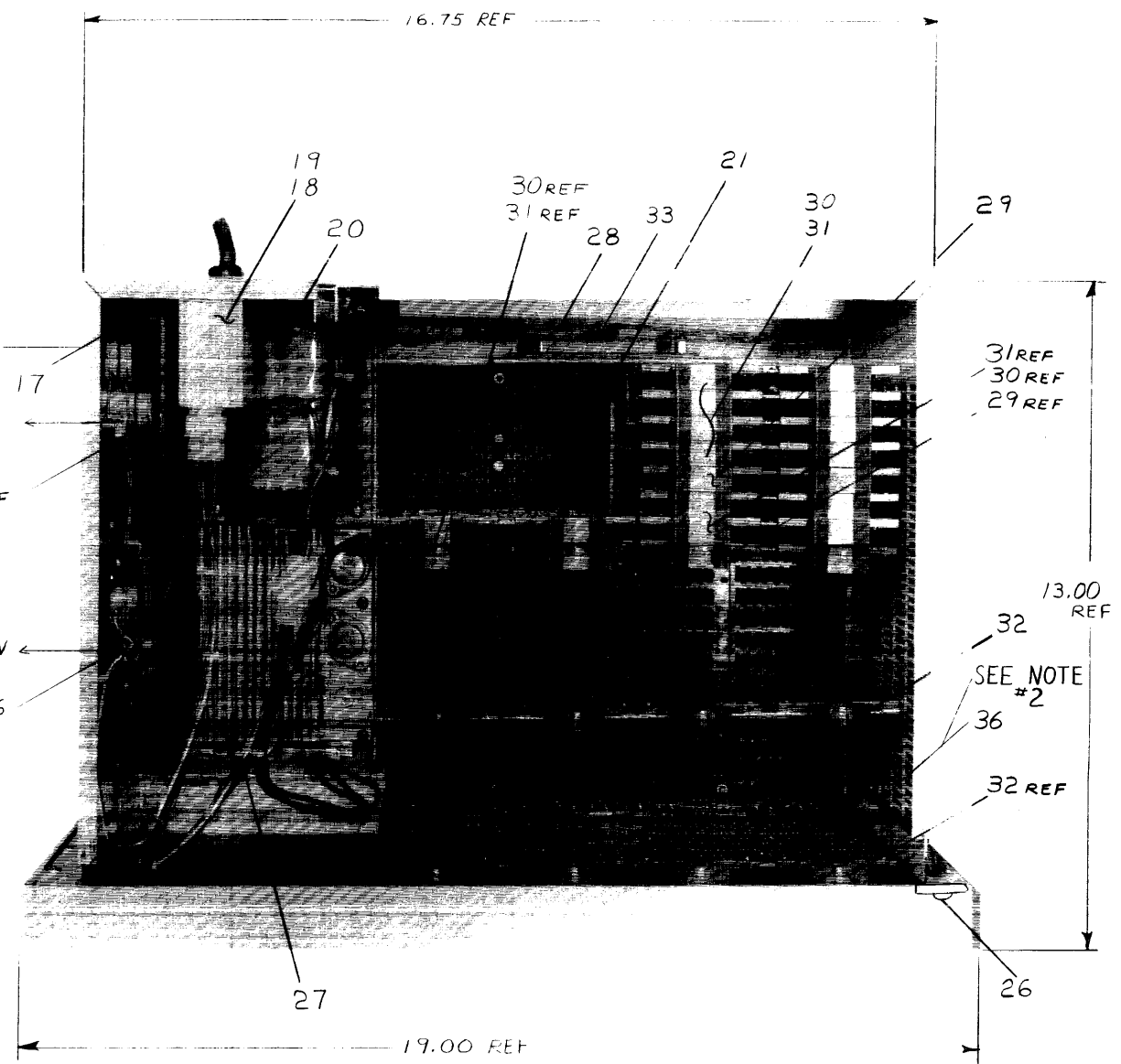

TOP VIEW WITH COVER (ITEM #7) REMOVED THROUGH (ITEM #17)

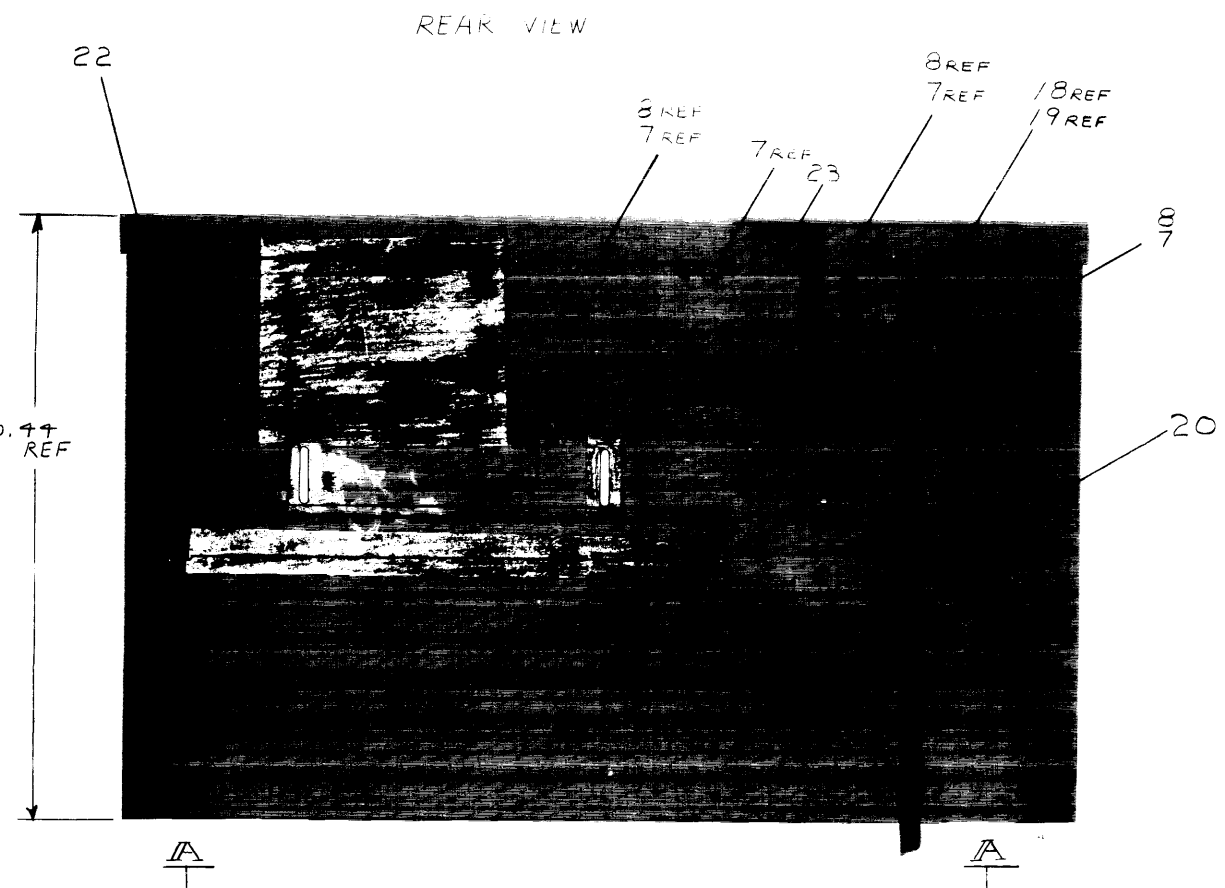

REAR VIEW

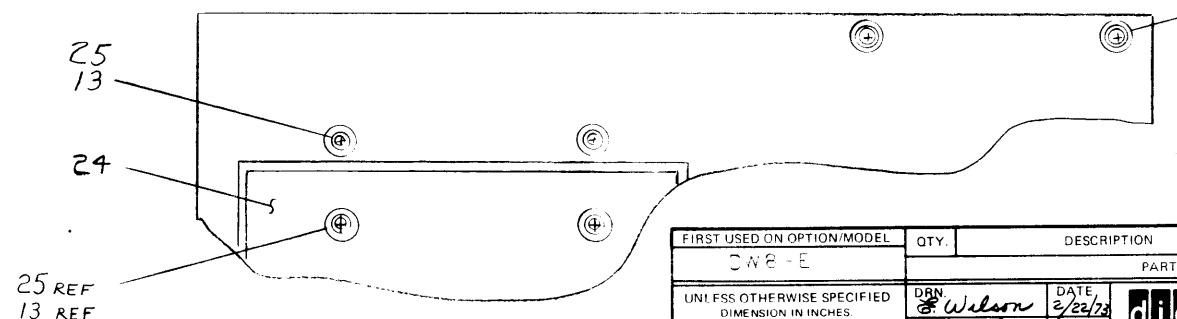

VIEW A-A (BOTTOM)
SCALE: NONE

FIRST USED ON OPTION/MODEL	QTY.	DESCRIPTION	PART NO.	ITEM NO.
DW8-E				
PARTS LIST				
UNLESS OTHERWISE SPECIFIED DIMENSION IN INCHES TOLERANCES	DRN <i>Wilson</i>	DATE 2/22/73	digital EQUIPMENT CORPORATION MAYNARD, MASSACHUSETTS	
DECIMALS ANGLES	CHKD <i>Mulligan</i>	DATE 5/16/73		
XXX .005 XX .02 X .1	ENG. <i>W. Reed</i>	DATE 2/23	TITLE UNIT ASSY	
REMOVE BURRS AND BREAK SHARP CORNERS. SURFACE QUALITY ✓	PROJ. ENG.	DATE 4/1/73		
MATERIAL	PROD. <i>W. Reed</i>	DATE	DW8-E	
FINISH				
	NEXT HIGHER ASSY		SIZE CODE	NUMBER
	B-DD-DW8-E		DW8-E-7	REV C
	SCALE		DIST	
	SHEET 2 OF 3			

REVISIONS	CHK	CHNGE	INT	RIV

THIS DRAWING AND SPECIFICATIONS, HEREIN, ARE THE PROPERTY OF DIGITAL EQUIPMENT CORPORATION AND SHALL NOT BE REPRODUCED OR COPIED OR USED IN WHOLE OR IN PART AS THE BASIS FOR THE MANUFACTURE OR SALE OF ITEMS WITHOUT WRITTEN PERMISSION. COPYRIGHT © 1973, DIGITAL EQUIPMENT CORPORATION.

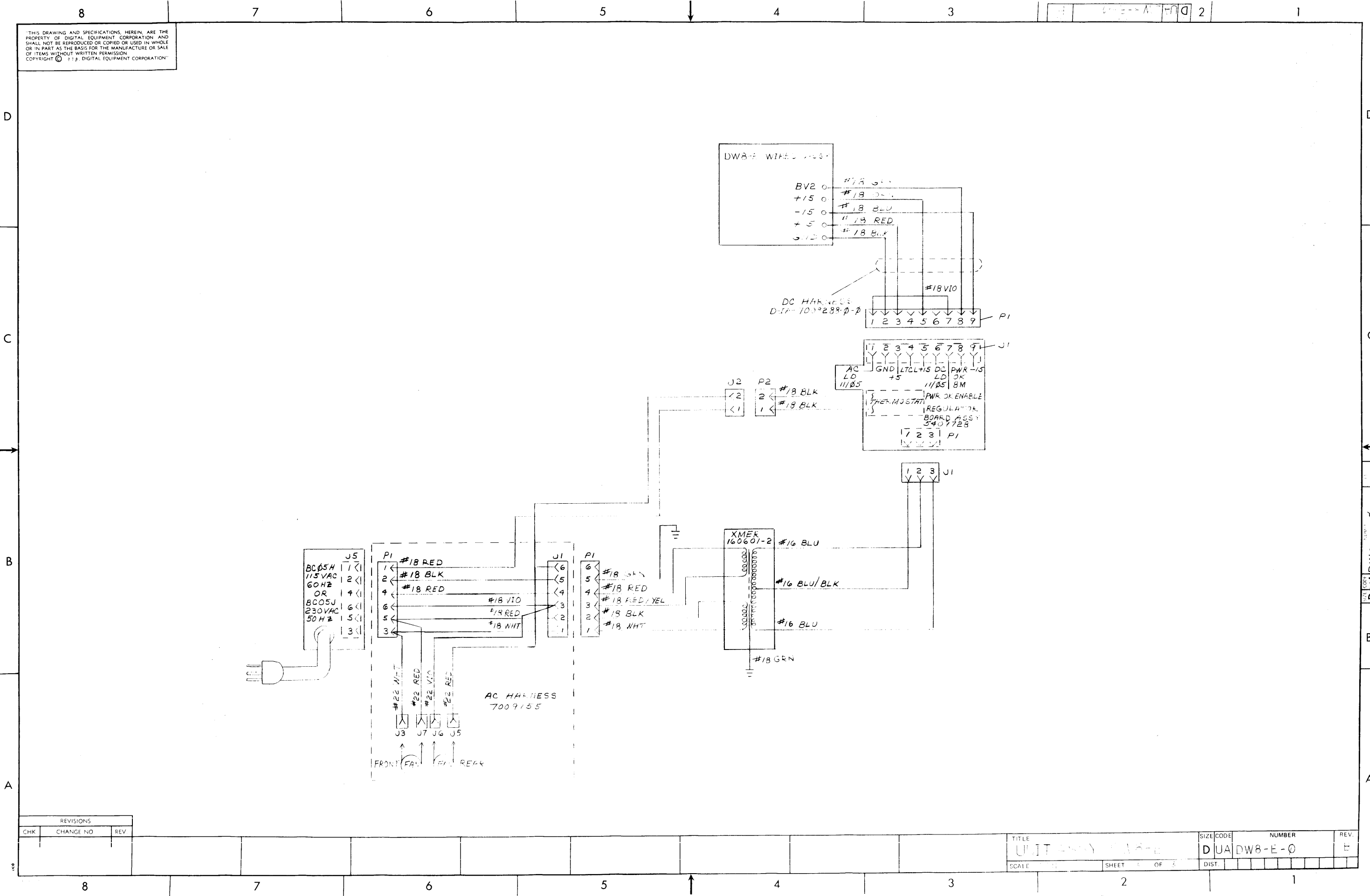

REVISIONS		
CHK	CHANGE NO	REV

TITLE	UNIT ASSEMBLY	SIZE CODE	NUMBER	REV.
	DUA DW8-E-0			E
SCALE	SHEET 4 OF 3	DIST.		

This drawing and specifications, herein, are the property of Digital Equipment Corporation and shall not be reproduced or copied or used in whole or in part as the basis for the manufacture or sale of items without written permission. COPYRIGHT © 1972

DIGITAL EQUIPMENT CORPORATION

REV B DW8-E-4

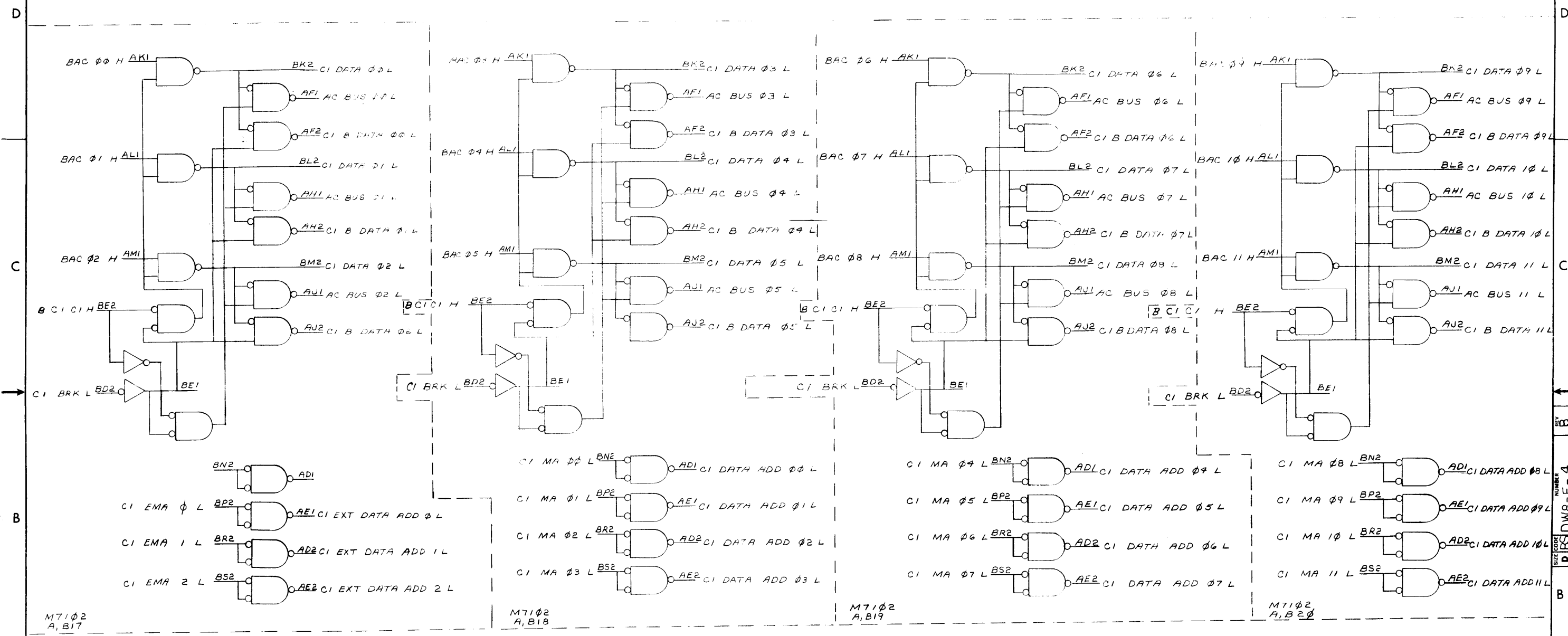

NOTE:
NEGATIVE BUS VERSION REPLACES
M7102'S WITH M7103'S

FIRST USED ON OPTION/MODEL	QTY.	DESCRIPTION	PART NO.	ITEM NO.
DW8-E		PARTS LIST		
UNLESS OTHERWISE SPECIFIED DIMENSION IN INCHES. TOLERANCES	DRN <i>Wilson</i>	DATE 10/9/72		
DECIMALS ANGLES	CHK'D <i>Wilson</i>	DATE 3/1/73		
XXX - 005 XX - 02 X - 1	±0° 30'	ENG <i>Beard</i>	DATE 2-2-73	TITLE I/O BUS CONVERTER POS BUS
REMOVE BURRS AND BREAK SHARP CORNERS SURFACE QUALITY	PROJ. ENG <i>Wilson</i>	DATE 2-2-73	PROD. <i>Wilson</i>	DATE 4/14/73
MATERIAL	NEXT HIGHER ASSY.	B-DD-DW8-C		
FINISH	SCALE NCNE	SHEET 1 OF 2	DIST	REV. B

REV	CHANGE NO	DATE	BY	REASON
A	0002			
B	0007			

DEC FORM NO DRD 102-B

REV B DW8-E-4

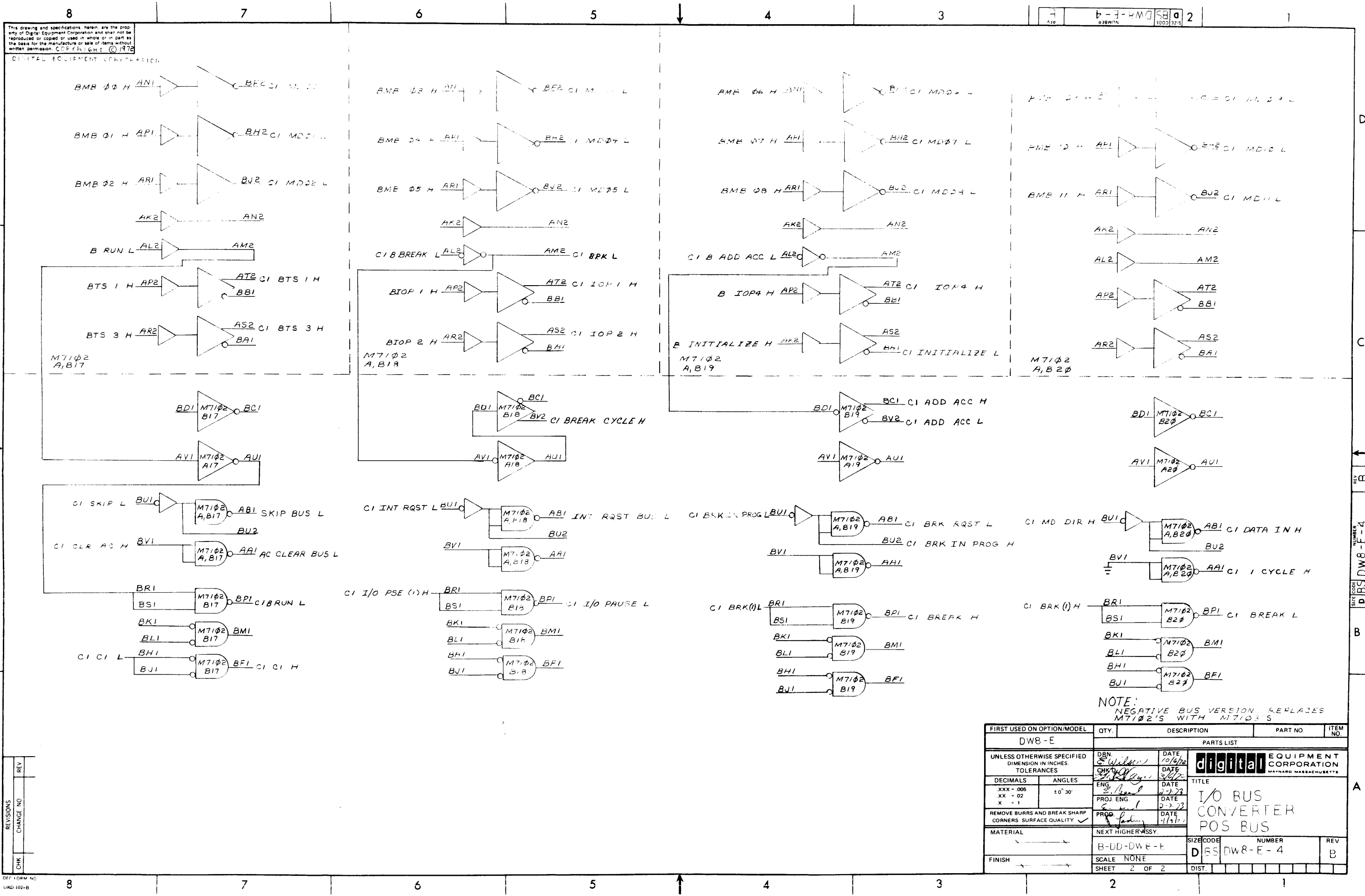

NOTE:
NEGATIVE BUS VERSION REPLACES
M7102'S WITH M7103'S

FIRST USED ON OPTION/MODEL	QTY.	DESCRIPTION	PART NO.	ITEM NO.
DW8-E				
PARTS LIST				
UNLESS OTHERWISE SPECIFIED DIMENSION IN INCHES TOLERANCES				
DECIMALS	ANGLES	DATE		
XXX - 005	± 0° 30'	12/6/72	TITLE	
XX - 02		3/4/72	I/O BUS	
X - 1		3/4/72	CONVERTER	
REMOVE BURRS AND BREAK SHARP CORNERS SURFACE QUALITY	PROD.	DATE	POS BUS	
MATERIAL	NEXT HIGHER ASSY.	1/1/72		
FINISH	B-DD-DW8-E		SIZE CODE	NUMBER
	SCALE NONE		DBS	DW8-E-4
	SHEET 2 OF 2		DIST.	REV
				B

REVISIONS
REV. CHANGE NO.
CHK. CHANGE NO.

THIS DRAWING AND SPECIFICATIONS HEREIN ARE THE PROPERTY OF DIGITAL EQUIPMENT CORPORATION, AND SHALL NOT BE REPRODUCED OR COPIED OR USED IN WHOLE OR IN PART AS THE BASIS FOR THE MANUFACTURE OR SALE OF ITEMS WITHOUT WRITTEN PERMISSION. COPYRIGHT © 1973 DIGITAL EQUIPMENT CORPORATION.

NOTES:
1. THE SIGNAL NAMES OF AN OPTION WHICH ARE PLUGGED INTO THE CONVERTER SECTION WILL ASSUME THE PREFIX "CI"

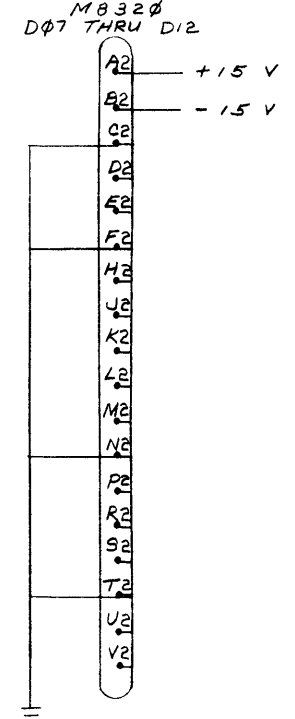
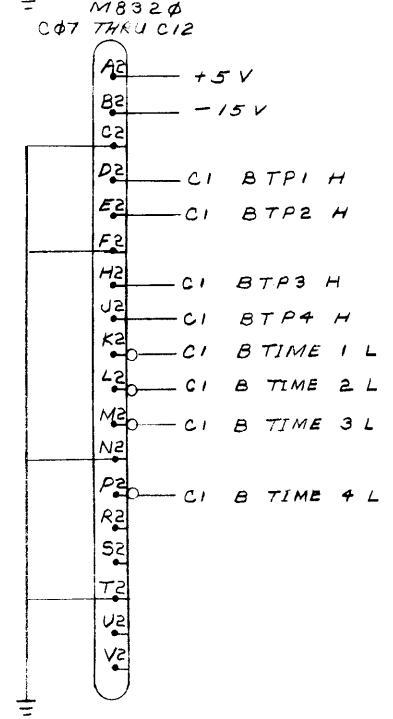
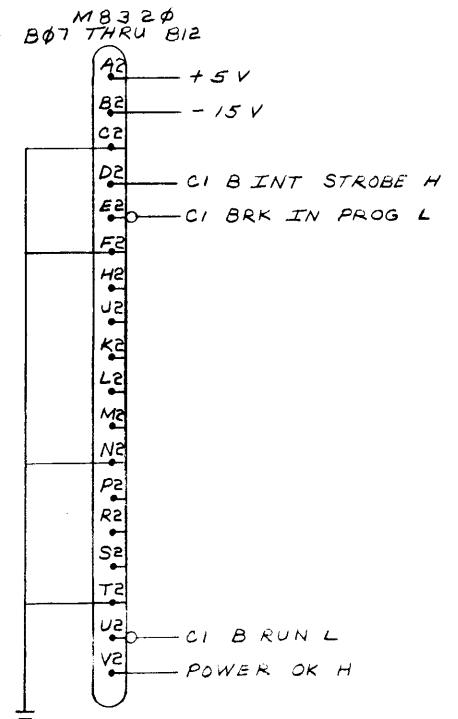
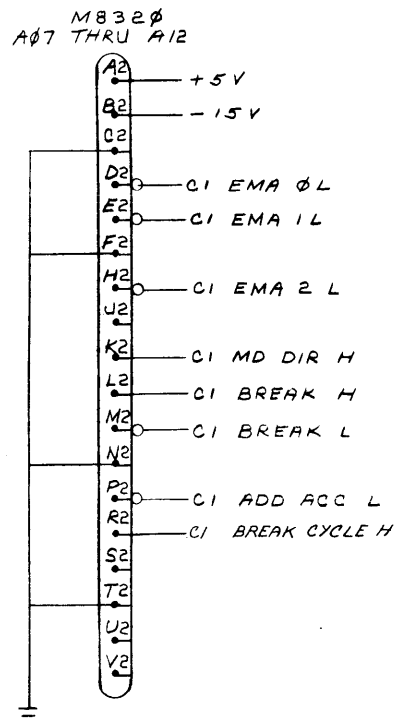
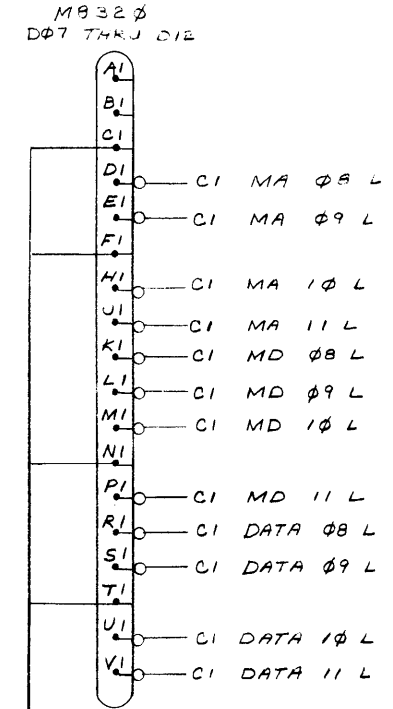
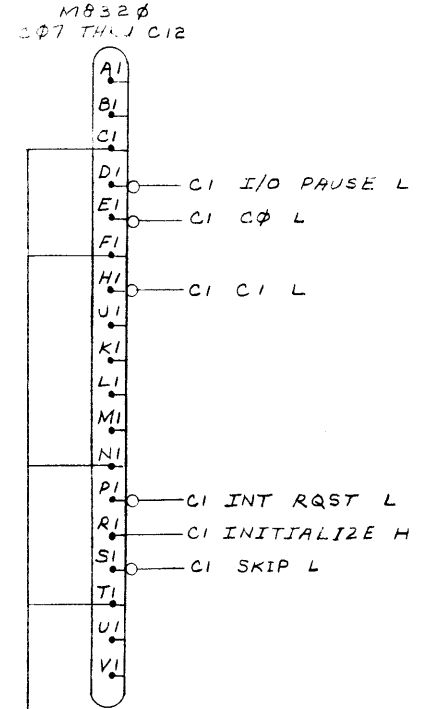
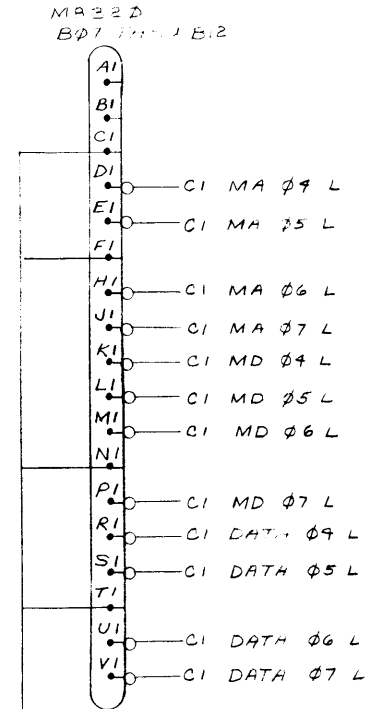
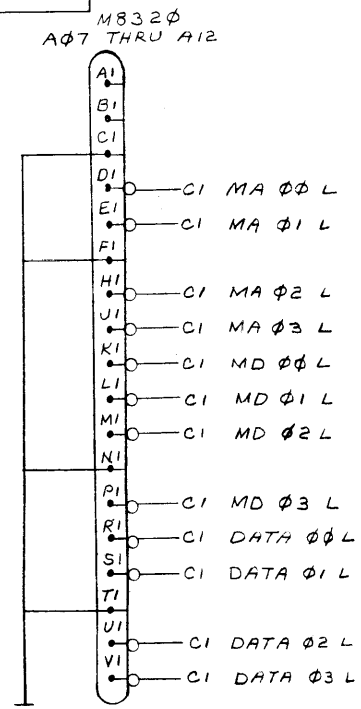

REV. NO.	DATE	BY	CHKD.
1	5-1-73	ED REED	5-1-73
2	5-1-73	ED REED	5-1-73
3	5-1-73	ED REED	5-1-73
4	5-1-73	ED REED	5-1-73
5	5-1-73	ED REED	5-1-73
6	5-1-73	ED REED	5-1-73
7	5-1-73	ED REED	5-1-73
8	5-1-73	ED REED	5-1-73

FIRST USED ON OPTION/MODEL DWS-E	QTY.	DESCRIPTION	PART NO.	ITEM NO.
PARTS LIST				
UNLESS OTHERWISE SPECIFIED DIMENSION IN INCHES				
DECIMALS .xxx = .005 .xx = .02 .x = .1	ANGLES 10 30'	TITLE I/O BUS CONVERTER SIGNALS		
REMOVE BURRS AND BREAK SHARP CORNERS SURFACE QUALITY Y		MATERIAL NEXT HIGHER ASSY.		
FINISH		SCALE B-DI-DW8-E		REV. B
SHEET 1 OF 1		DIST. DIC DW8-E-5		

REV. B
NUMBER
DIC DW8-E-5

This drawing and its contents are the property of Digital Equipment Corporation and shall not be reproduced or copied in whole or in part as written permission without the written permission of Digital Equipment Corporation.

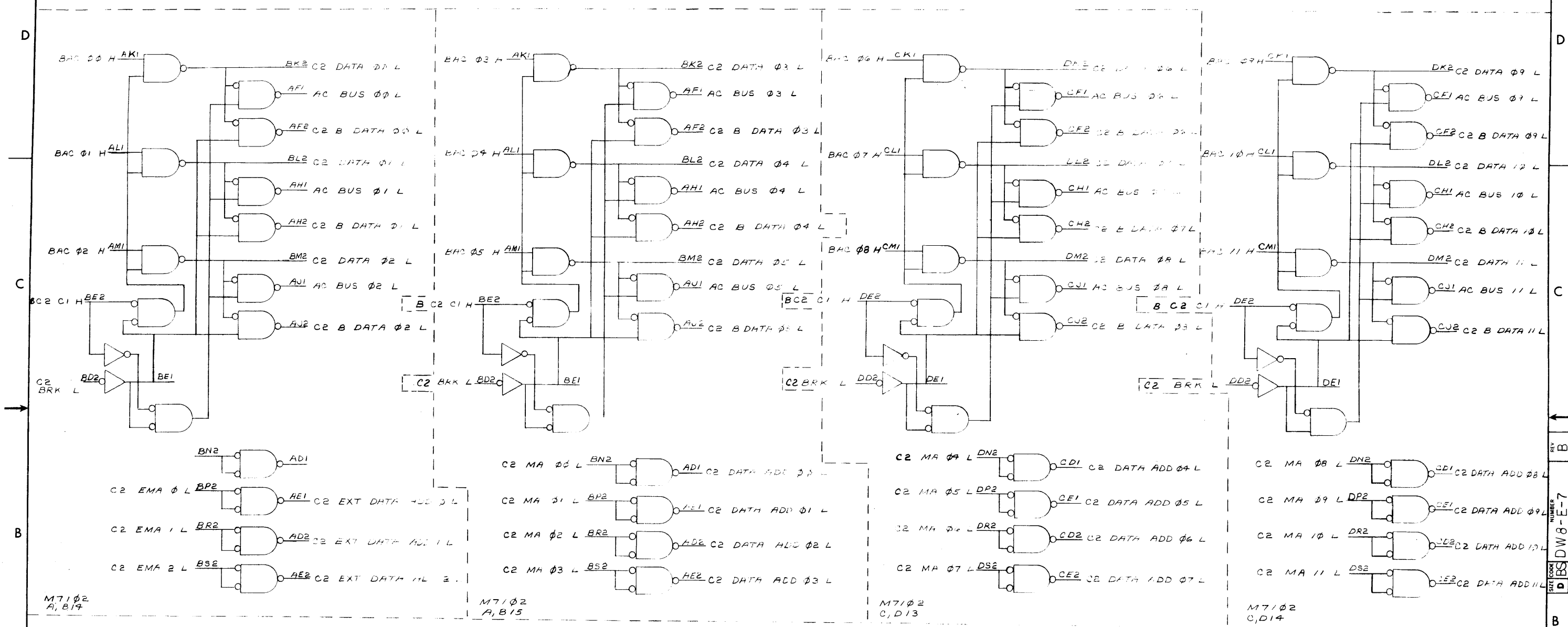

REV	CHG NO	DATE	BY	CHK'D	DATE
A	0002	10/11/72	W. J. Wilson	W. J. Wilson	10/11/72
B	0001	10/11/72	W. J. Wilson	W. J. Wilson	10/11/72
C	0001	10/11/72	W. J. Wilson	W. J. Wilson	10/11/72
D	0001	10/11/72	W. J. Wilson	W. J. Wilson	10/11/72

NOTE:
 NEGATIVE BUS VERSION REPLACES
 M7102'S WITH M7103'S

FIRST USED ON OPTION/MODEL	QTY.	DESCRIPTION	PART NO.	ITEM NO.
DWR-E				
PARTS LIST				
UNLESS OTHERWISE SPECIFIED DIMENSION IN INCHES TOLERANCES		DRN: W. J. Wilson	DATE: 10/11/72	digital EQUIPMENT CORPORATION MAYNARD MASSACHUSETTS
DECIMALS	ANGLES	CHK'D: W. J. Wilson	DATE: 10/11/72	
XXX - 005	± 0.30	ENG: W. J. Wilson	DATE: 10/11/72	
XX - 02		PROJ. ENG.:	DATE: 10/11/72	
REMOVE BURRS AND BREAK SHARP CORNERS SURFACE QUALITY		PROD: W. J. Wilson	DATE: 10/11/72	TITLE I/O BUS EXPANDER FCS BUS
MATERIAL	NEXT HIGHER ASSY.	SCALE: NONE		REV: B
FINISH	B-D-E-DWR-E	SHEET 1 OF 2		NUMBER: D BSI DW8-E-7

8

7

6

5

4

3

8

2

1

THIS DRAWING AND SPECIFICATIONS HEREIN ARE THE PROPERTY OF DIGITAL EQUIPMENT CORPORATION, AND SHALL NOT BE REPRODUCED OR COPIED OR USED IN WHOLE OR IN PART AS THE BASIS FOR THE MANUFACTURE OR SALE OF ITEMS WITHOUT WRITTEN PERMISSION.
 COPYRIGHT © 1973 DIGITAL EQUIPMENT CORPORATION.

NOTE:
 1. THE SIGNAL NAMES OF AN OPTION WHICH IS PLUGGED INTO THE EXPANDER SECTION WILL ASSUME THE PREFIX "C2"

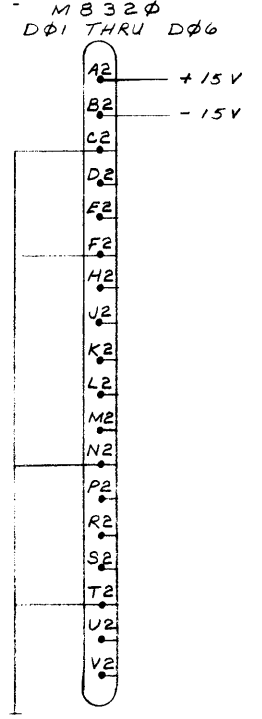
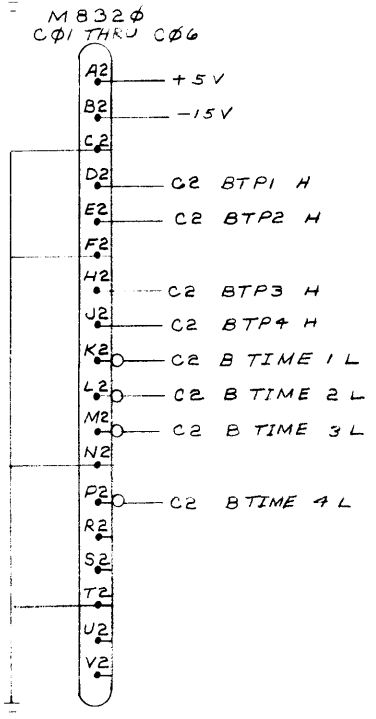
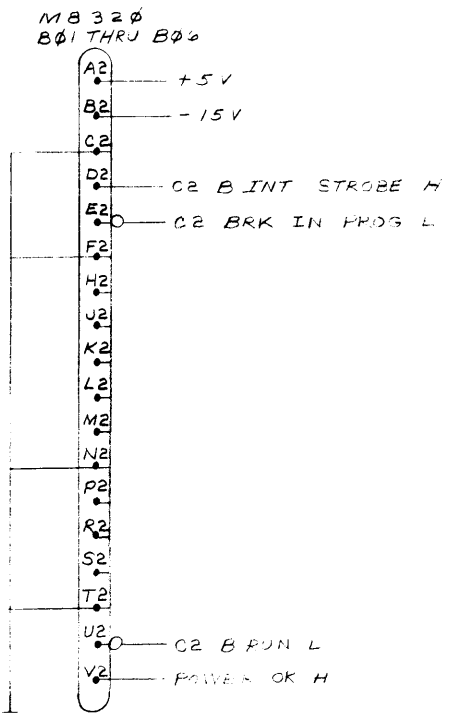
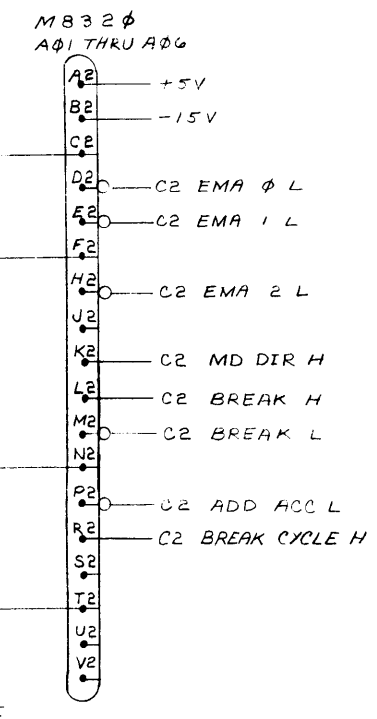
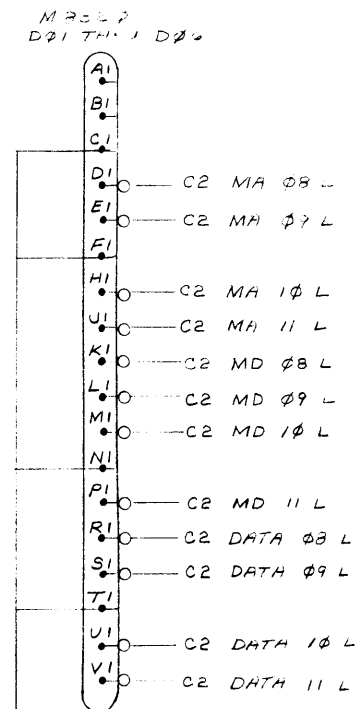
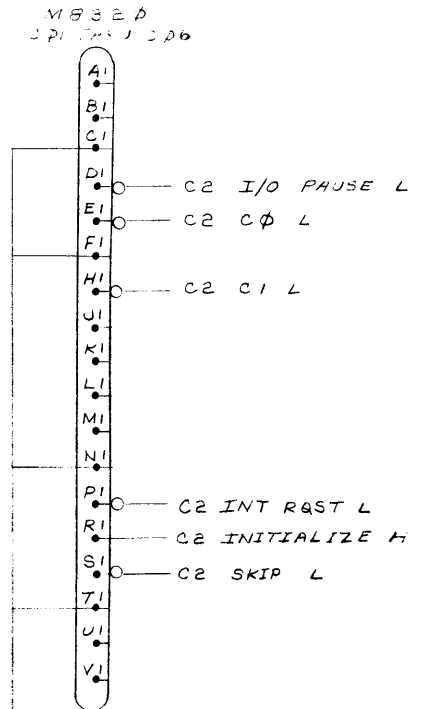
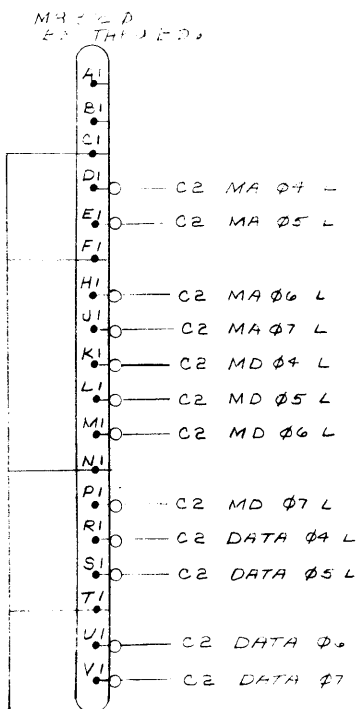
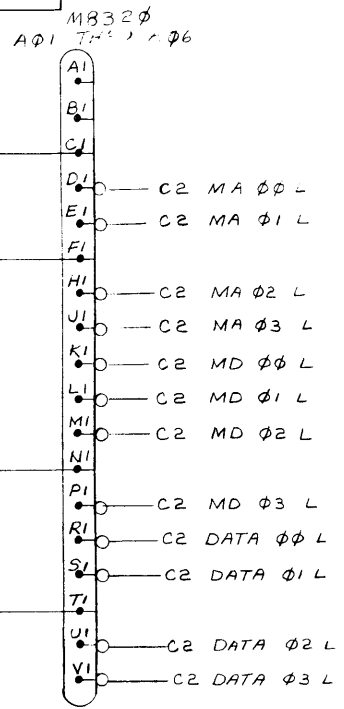

REV	DATE	BY	CHKD
1	7-1-73	W	W
2	7-1-73	W	W
3	7-1-73	W	W
4	7-1-73	W	W
5	7-1-73	W	W
6	7-1-73	W	W
7	7-1-73	W	W
8	7-1-73	W	W

FIRST USED ON OPTION/MODEL	QTY.	DESCRIPTION	PART NO.	ITEM NO.
DWS-E				
PARTS LIST				
UNLESS OTHERWISE SPECIFIED DIMENSION IN INCHES	DRN W Wilson	DATE 2/1/73	digital EQUIPMENT CORPORATION MAYNARD, MASSACHUSETTS	
TOLERANCES	CHKD W Wilson	DATE 7/1/73	TITLE I/O BUS EXPANDER SIGNALS	
DECIMALS .005	ENG W Wilson	DATE 2-1-73	MATERIAL NEXT HIGHER ASSY.	
ANGLES 0 30	PROJ. ENG. W Wilson	DATE 7-1-73	FINISH SCALE	
REMOVE BURRS AND BREAK SHARP CORNERS SURFACE QUALITY Y	PROJ. DATE 7-1-73	DATE 7-1-73	SHEET 1 OF 1	
			DIST.	
			SIZE CODE NUMBER REV. D I C DW8-E-8 B	

8

7

6

5

4

3

2

1

REV. NUMBER
DW8-E-8
REV. B

This drawing and its specifications, herein are the property of Digital Equipment Corporation and shall not be reproduced or copied or used in whole or in part as the basis for the manufacture or sale of items without written permission. **COPYRIGHT © 1972**
DIGITAL EQUIPMENT CORPORATION

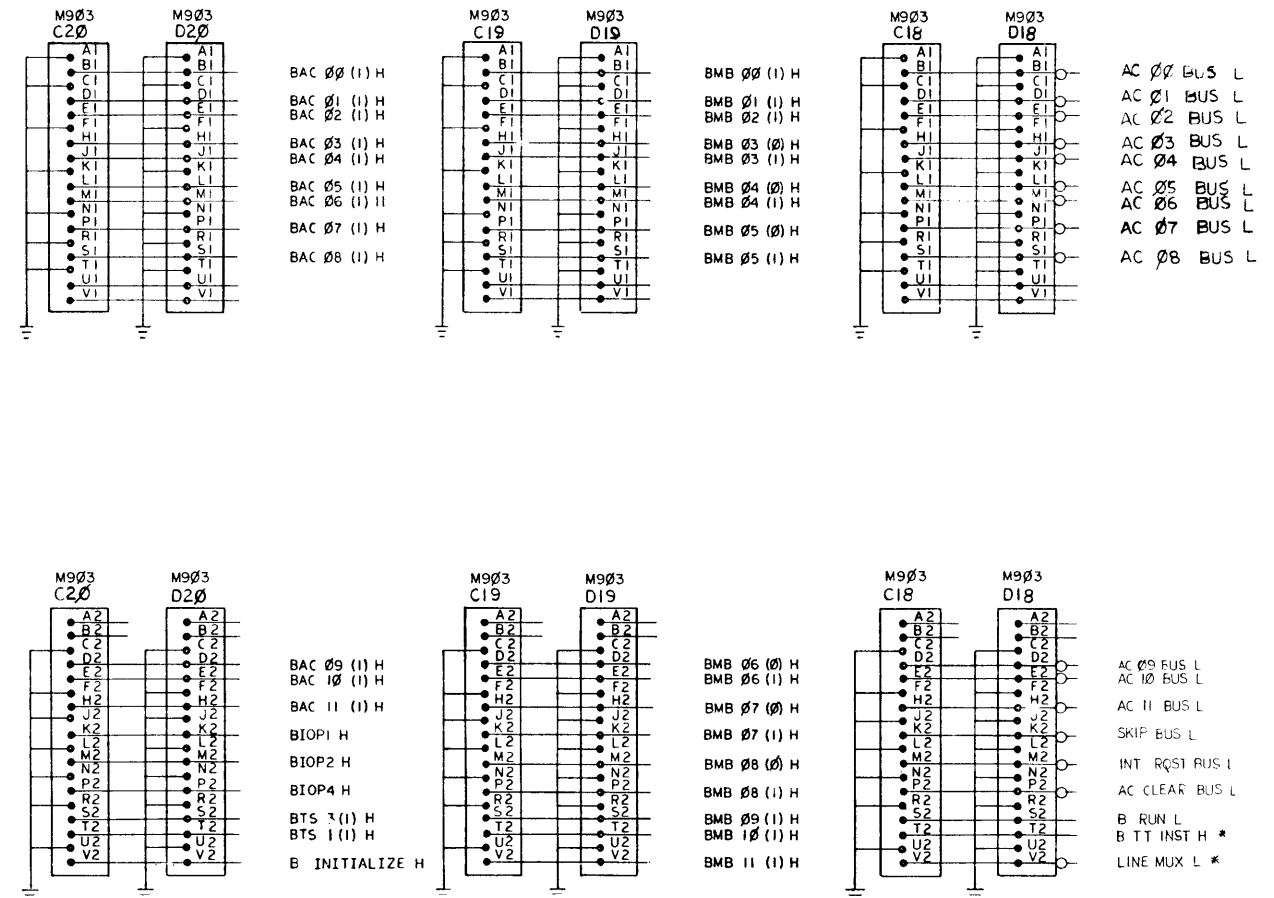

NOTES:
 1. SIGNALS MARKED WITH AN ASTERISK ARE NOT USED IN PDP 8/L BUT RESERVED FOR SPECIFIC USE IN PDP 8/I.
 2. BC08A IN C15 USED ONLY ON A PDP 8 OR LI-C-8 AND ADD ICC-2 FROM C15 T2 TO GND.

REV. NO.	REV.
00002	A
ED REED	
5/1/72	

FIRST USED ON OPTION / MODEL
DW8-E

DO NOT SCALE DRAWING
 UNLESS OTHERWISE SPECIFIED
 DIMENSION IN INCHES
 TOLERANCES
 DECIMALS FRACTIONS ANGLES
 = .009 = 1/64 = 0°30'
 FINAL SURFACE QUALITY
 REMOVE BURRS AND BREAK SHARP CORNERS
 MATERIAL
 FINISH

QTY.	DESCRIPTION	PART NO.	ITEM NO.
PARTS LIST			
DRN	DATE	EQUIPMENT CORPORATION	
CHKD	DATE	MAYNARD MASSACHUSETTS	
ENG	DATE	TITLE	
PROJ. ENG.	DATE	10 CONNECTORS	
PROD.	DATE	NEAT-HIGHER ASSY	
B-DD-DW8-E		SPT. CODE	NUMBER
SCALE		CITC DW8-E-2	REV. A
FEET OF 2		DIST.	

This drawing and specifications herein are the property of Digital Equipment Corporation and shall not be reproduced or copied or used in whole or in part as the basis for the manufacture or sale of items without written permission. **COPYRIGHT © 1972 DIGITAL EQUIPMENT CORPORATION**

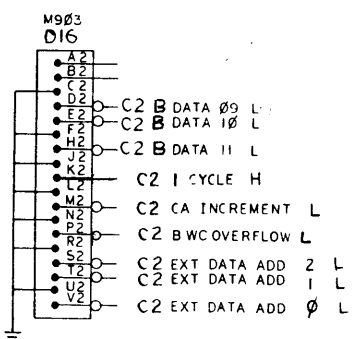
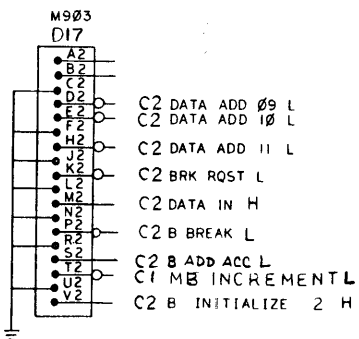
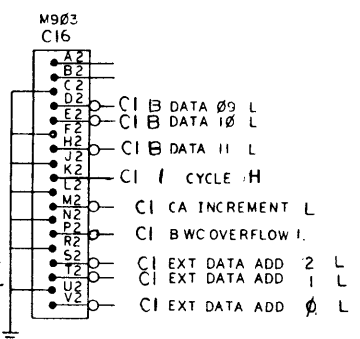
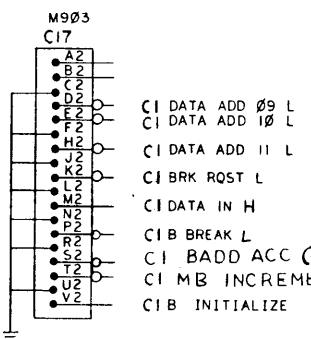
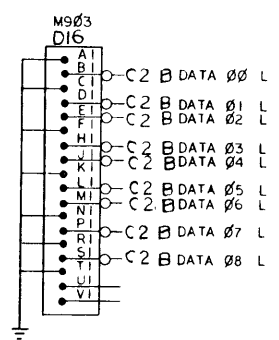
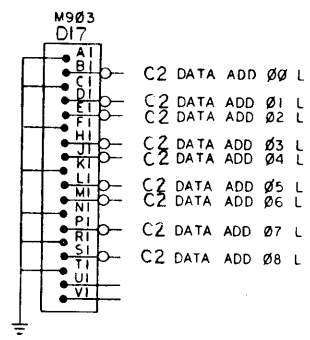
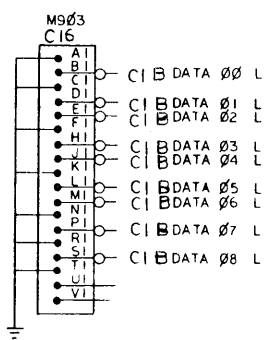
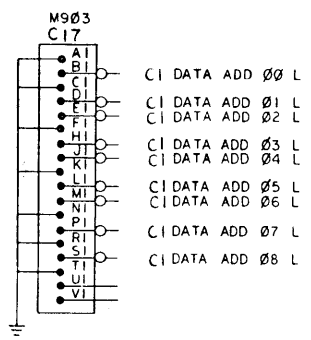

REV	
CHANGE NO	
CHK	

FIRST USED ON OPTION / MODEL
DW 8-E

DO NOT SCALE DRAWING
UNLESS OTHERWISE SPECIFIED
DIMENSION IN INCHES
TOLERANCES
DECIMALS FRACTIONS ANGLES
± .005 ± 1/64 ± 0°30'
FINAL SURFACE QUALITY
REMOVE BURRS AND BREAK SHARP CORNERS

QTY.	DESCRIPTION	PART NO.	ITEM NO.
PARTS LIST			
DRN	DATE	DIGITAL EQUIPMENT CORPORATION MAYNARD, MASSACHUSETTS	
CHKD	DATE	TITLE	
ENG	DATE	10 CONNECTORS	
PROJ. ENG.	DATE	NEXT HIGHER ASSY	
PROD	DATE	B-DD-DW8-E	
MATERIAL		SIZE CODE	NUMBER
FINISH		SHEET	REV
SCALE		DIST.	A
SHEET 2 OF 2		CIC DW8-E-2	

CIC DW8-E-2

This drawing and specifications, herein, are the property of Digital Equipment Corporation and shall not be reproduced or copied or used in whole or in part as the basis for the manufacture or sale of items without written permission. COPYRIGHT © 1972 DIGITAL EQUIPMENT CORPORATION

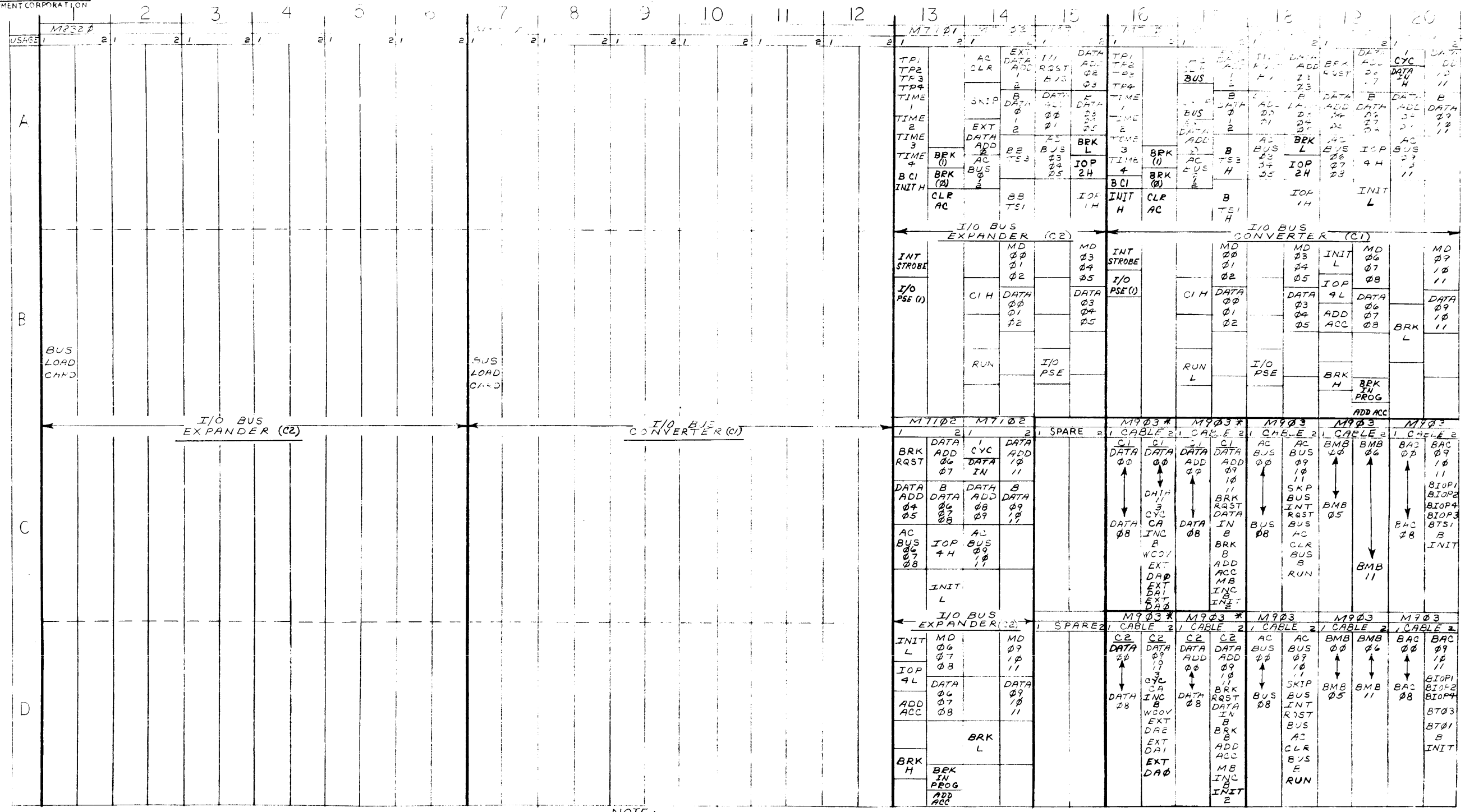

- NOTE:**
1. IN NEGATIVE BUS VERSION THE M7102'S ARE REPLACED BY M7103'S
 2. * DATA CABLES IN C16 AND C17 ARE FOR I/O BUS CONVERTER (C1)
DATA CABLES IN D16 AND D17 ARE FOR I/O BUS EXPANDER (C2)
 3. SC08A CABLE IN C15 IS FOR PDP-8 OR ENG-8 ONLY
 4. QUAD-SLOTS 07-12 AND SLOTS A,B16-A,B20 ARE THE BASIC CONVERTER SECTION. (SIGNAL NAMES PREFIXED BY "C1")
 5. QUAD-SLOTS 01-06 AND SLOTS A,B13-A,B15 & C,D13-C,D14 ARE THE EXPANDER SECTION. (SIGNAL NAMES PREFIXED BY "C2")

REV.	CHANGE NO.	DATE
A	DW8-E-00002	5-2-73
	ED REED	5-3-73

FIRST USED ON OPTION/MODEL
DW8-E

DO NOT SCALE DRAWING
UNLESS OTHERWISE SPECIFIED DIMENSION IN INCHES
TOLERANCES
DECIMALS FRACTIONS ANGLES
= .001 = 1/64 = 0°00'
FINAL SURFACE QUALITY
REMOVE BURRS AND BREAK SHARP CORNERS

QTY.	DESCRIPTION	PART NO.	ITEM NO.
PARTS LIST			
	digital EQUIPMENT CORPORATION MAYNARD MASSACHUSETTS		
DRN: [Signature]		DATE: 12/31/72	
CHK: [Signature]		DATE: 5/1/73	
ENG: [Signature]		DATE: 2-2-73	
PROJ. ENG: [Signature]		DATE: 2-3-73	
PROD: [Signature]		DATE: 4/9/73	
MODULE UTILIZATION			
NEXT HIGHER ASSY B-DD DW8-E			SIZE/NUMBER D16/DW8-E-1
SCALE: NONE			REV. A
SHEET	OF	DIST.	

This drawing and specifications herein are the property of Digital Equipment Corporation and shall not be reproduced or copied or used in whole or in part as the basis for the manufacture or sale of items without written permission. © 1972 DIGITAL EQUIPMENT CORPORATION

NOTES:
 1. CONNECTIONS ON ITEM 9 & 13 TO BE LOCATED & SOLDERED AT MINIMUM PRACTICAL HEIGHT ABOVE BLOCKS.
 2. USE YELLOW WIRE (#22) FOR MACHINE WRAPPED & BLUE WIRE (#23) FOR HAND WRAPPED WIRING.

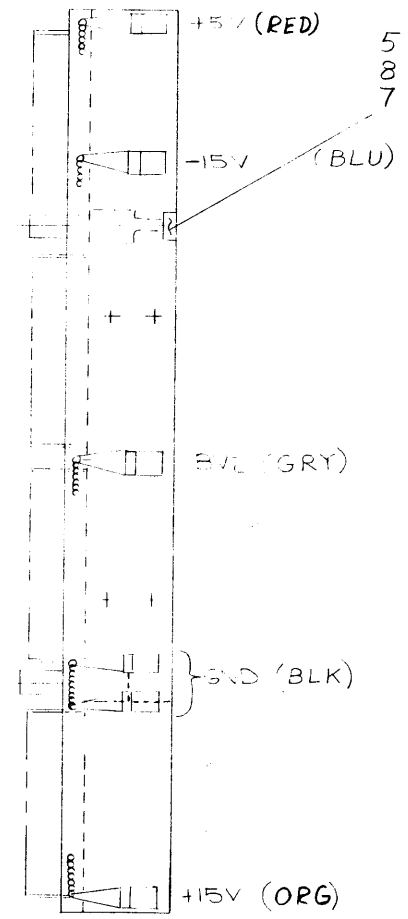
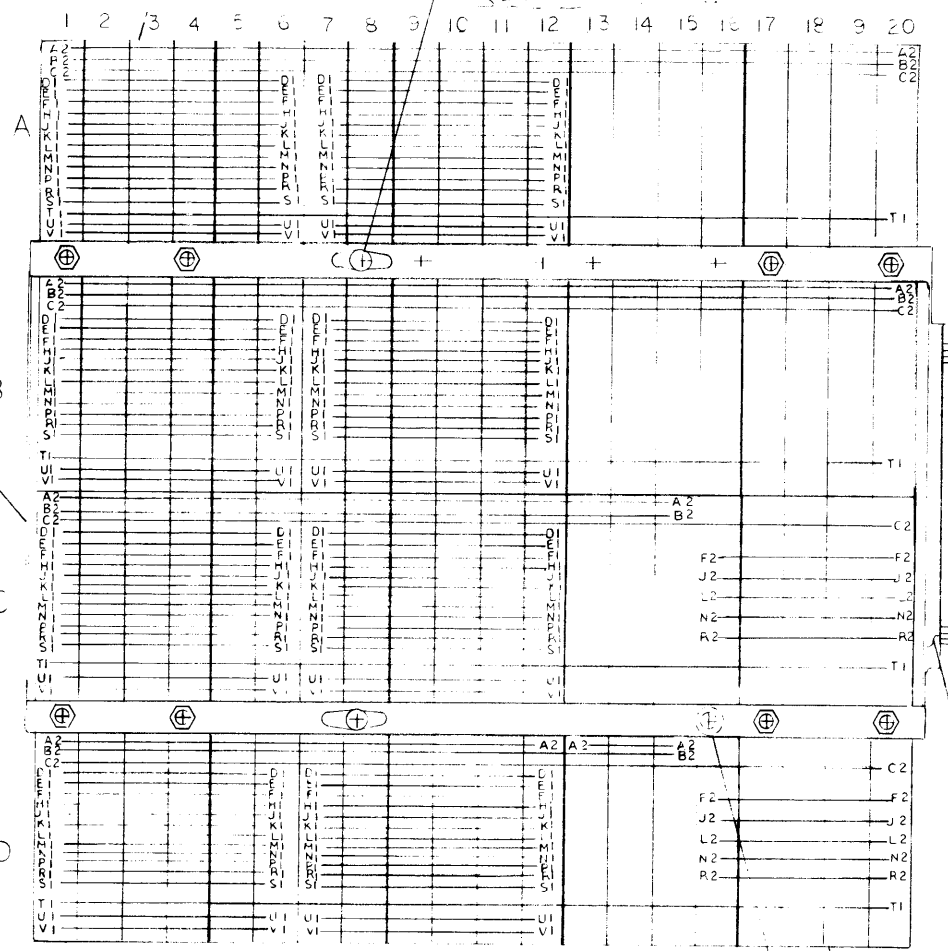

ITEM NO	DESCRIPTION	FROM		TO		
		AWG	COLOR	CONNECTION	WITH CONNECTION	WITH CONNECTION
12	RED #22 SOLID			+5	A2 Ø A2	SOLDER
+	RED			+5	B2 Ø A2	
13	RED			+5	C15 A2	
	RED			+5	D15 A2	
11	BLK			GND	A2 Ø C2	
+	BLK			GND	B2 Ø C2	
3	BLK			GND	C2 Ø C2	
13	BLK			GND	D2 Ø C2	
13+20	GRY			BV2	B12 V2	
13	BLU			-15V	A2 Ø B2	
+	BLU			-15V	B2 Ø B2	
18	BLU			-15V	C15 B2	
	BLU			-15V	D15 B2	
13+19	ORG			#22 SOLID +15V	D12 A2	SOLDER

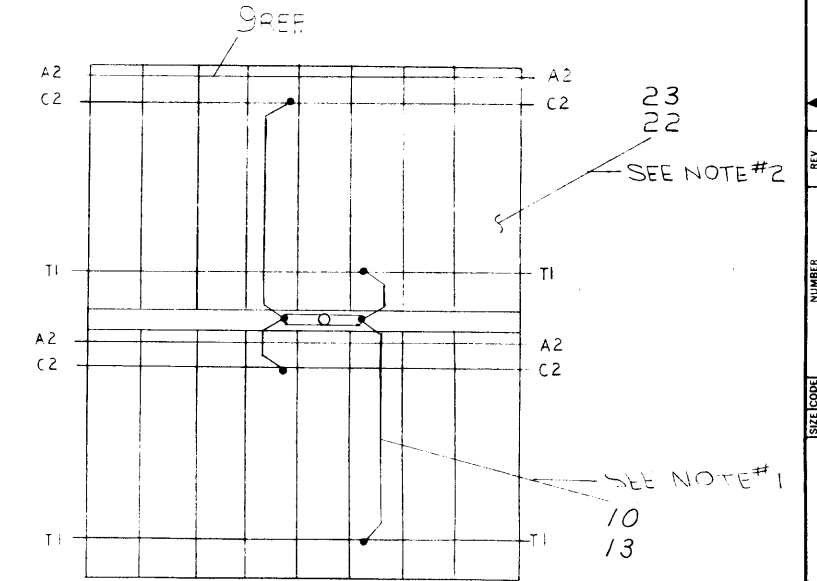

FIRST USED ON OPTION/MODEL	QTY.	DESCRIPTION	PART NO.	ITEM NO.
DW8-E				
PARTS LIST				
UNLESS OTHERWISE SPECIFIED DIMENSION IN INCHES TOLERANCES		DRN Wilson 10/18/72	DATE	
DECIMALS ANGLES		CHK'D 10/27/72	DATE	
XXX - 005 XX - 02 X - 1		ENG 10/27/72	DATE	TITLE
REMOVE BURRS AND BREAK SHARP CORNERS SURFACE QUALITY		PROJ. ENG 10/27/72	DATE	WIRED ASS'Y (DW8-E)
MATERIAL		PROD. 10/27/72	DATE	NEXT HIGHER ASSY
FINISH		SCALE 1:1	SHEET 1 OF 1	SIZE CODE NUMBER REV.
				DAD7009154-0-0

BRUNING 40-107 15968
 DEF. FORM NO. DRG 100-A

REV. NUMBER
 DAD 7009154-0-0

4

3

2

1

This drawing and specifications, herein, are the property of Digital Equipment Corporation and shall not be reproduced or copied or used in whole or in part as the basis for the manufacture or sale of items without written permission. COPYRIGHT © 1973

DIGITAL EQUIPMENT CORPORATION

B

B

A

A

FIRST USED ON OPTION MODEL	QTY.	DESCRIPTION	PART NO.	ITEM NO.
DW8-E				

REVISIONS		REV.
CHK	CHANGE NO.	A
<i>PA</i>	DW8E-00002	
	<i>B. B. Rodgers 5-1-73</i>	
	ED REED	
	<i>5-8-73</i>	
	DW8E-00007	F
	<i>J. Charles 7-16-73</i>	
	EL REEL	
	<i>8/1/73</i>	

DRN	DATE
<i>H. J. G...</i>	<i>3/7/73</i>
CHK'D.	DATE
<i>George Hall</i>	<i>3/27/73</i>
ENG.	DATE
<i>1</i>	<i>4/1/73</i>
PROJ. ENG.	DATE
<i>1</i>	<i>4/1/73</i>
PROD.	DATE
<i>1</i>	<i>4/1/73</i>

digital EQUIPMENT CORPORATION
MAYNARD, MASSACHUSETTS

TITLE
DW8-E
WIRE LIST

NEXT HIGHER ASSEMBLY
B-DD-DW8-E
SCALE <i>---</i>
SHEET <i>1</i> OF <i>1</i>

SIZE	CODE	NUMBER	REV.
K	WL	DW8-E-11	B
DIST.			

4

3

2

1

This drawing and specifications herein are the property of Digital Equipment Corporation and shall not be reproduced or copied or used in whole or in part as the basis for the manufacture or sale of items without written permission. COPYRIGHT © 1978 DIGITAL EQUIPMENT CORPORATION

NOTES:
1. UNLESS OTHERWISE NOTED ALL RESISTORS IS IN OHMS.

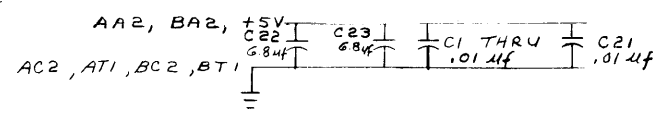
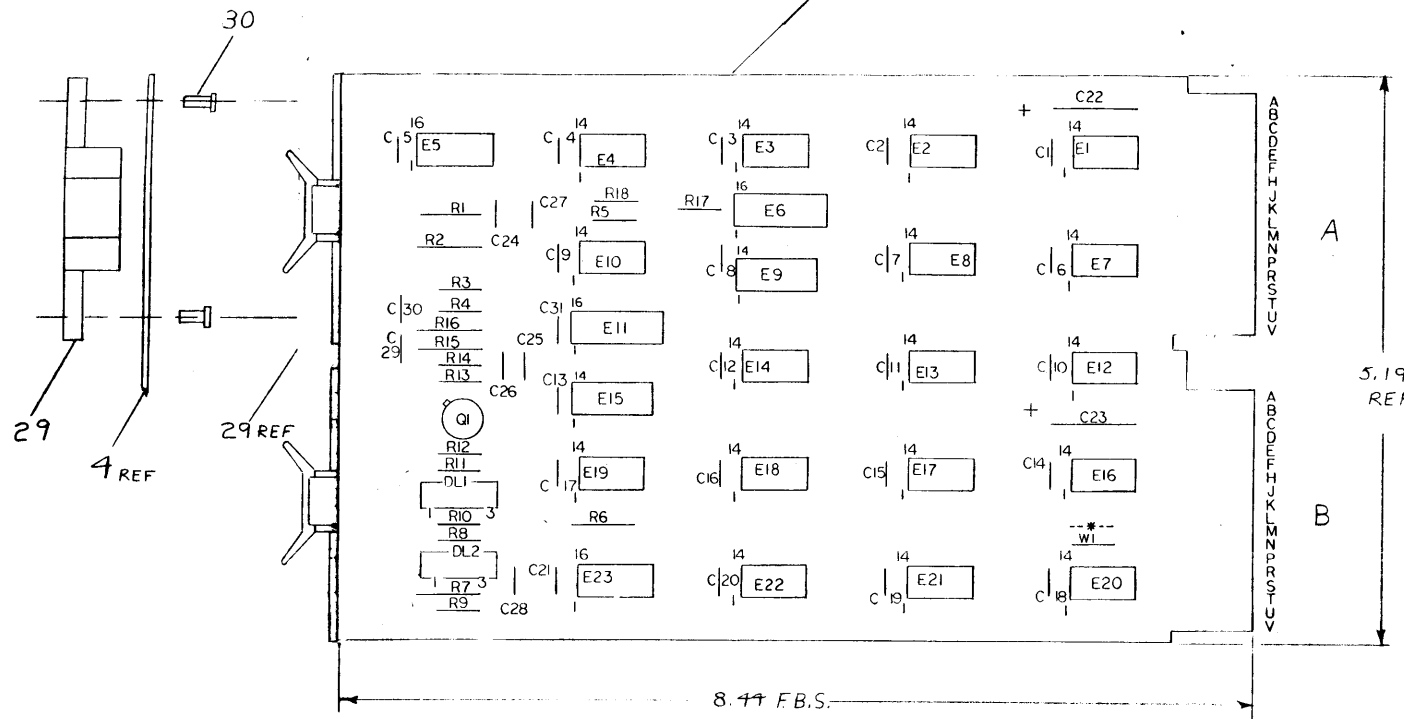

REF	QTY	REF DESIGNATION	DESCRIPTION	PART NO.	FILM NO.
			X-Y COORDINATE HOLE LOCATION	K-20-M7101-1	1
			ASSY/DRILLING HOLE LAYOUT	DWA-M7101-1-5	2
			MODULE ECO HISTORY	B-MH-M7101-1	3
			ETCHED CIRCUIT BOARD	5003665	4
1	1	C28	CAP. 47µF 100V 5% DM	10-00011	5
1	1	C25	CAP. 68µF 100V 5% DM	10-00014	6
1	1	C27	CAP. 4.7µF 100V 5% DM	10-00024	7
2	2	C22, C23	CAP. 68µF 35V 10% TANT	10-05306	8
23	23	C1 THRU C31	CAP. .01µF 100V 20% DISC	10-01610	9
1	1	C24	CAP. 390pf 100V 5% DM	10-01631	10
2	2	R4, R5	RES. 100 1/4W 5%	13-00229	11
3	3	R3, R17, R18	RES. 220 1/4W 5%	13-00271	12
4	4	R8, R9, R10, R11	RES. 390 1/4W 5%	13-00307	13
1	1	R13	RES. 470 1/4W 5%	13-00316	14
2	2	R12, R14	RES. 27 1/4W 5%	13-01522	15
1	1	R2	RES. 10K 1/8W 1%	13-03312	16
3	3	R1, R6, R7	RES. 511K 1/8W 1%	13-04854	17
1	1	Q1	TRAN. DEC 3009B	16-03100	18
2	2	DL1, DL2	DL 30NS	16-05528	19
1	1	E14	I.C. DEC 74H40	19-05586	20
6	6	E3, E4, E9, E10, E15, E20	I.C. DEC 74H00	19-09056	21
2	2	E12, E18	I.C. DEC 74H53	19-09062	22
1	1	E19	I.C. DEC 74H11	19-09267	23
6	6	E2, E8, E13, E17, E21	I.C. DEC 74H74	19-09667	24
1	1	E7	I.C. DEC 7416	19-09928	25
1	1	E1	I.C. DEC 7417	19-09929	26
1	1	E16	I.C. DEC 74H04	19-09931	27
3	3	E5, E11, E23	I.C. DEC 74123	19-10436	28
2	2		HANDLE FLIPCHIP MAGENTA	9008337-6	29
4	4		EYELETS (GS-4-7)	9006732	30
1	1	E6	DL 100NS	1610033-0	31
2	2	R15, R16	RES. 27.4K 1/8W, 1%	1309417	32
1	1	C29	CAP. 27 pf 100V 5% DM	1001739	33
1	1	C30	CAP. 560 pf 100V 5% DM	1000025	34

IC TYPE	GND	+5V
IC DEC 74123	B	16
GND AND 5V ARE USUALLY PIN 7 AND 14 RESPECTIVELY EXCEPTIONS ARE STATED ABOVE		
IC PIN LOCATIONS		

FIRST USED ON OPTION MODEL DWE-E		ETCH BOARD REV F		PARTS LIST	
DRN	DATE	digital EQUIPMENT CORPORATION			
CHK'D	DATE	TITLE DWE-E CONTROL			
ENG.	DATE	SIZE CODE NUMBER REV. DCSM7101-0-1 F			
PROJ. ENG.	DATE	SCALE			
PROD.	DATE	SHEET 1 OF 2			
NEXT HIGHER ASSY B-DD-DWR-E		SEMICONDUCTOR CONVERSION CHART			
DEC NO.	EIA NO.	DEC NO.	EIA NO.		

DRAWING 40-522 16899 DEC FORM NO. DRD-135A

DCSM7101-0-1

This drawing and specifications, herein, are the property of Digital Equipment Corporation and shall not be reproduced or copied or used in whole or in part as the basis for the manufacture or sale of items without written permission. COPYRIGHT © 1972 DIGITAL EQUIPMENT CORPORATION

NOTE:
UNLESS OTHERWISE STATED ALL RESISTANCE IS IN OHMS.

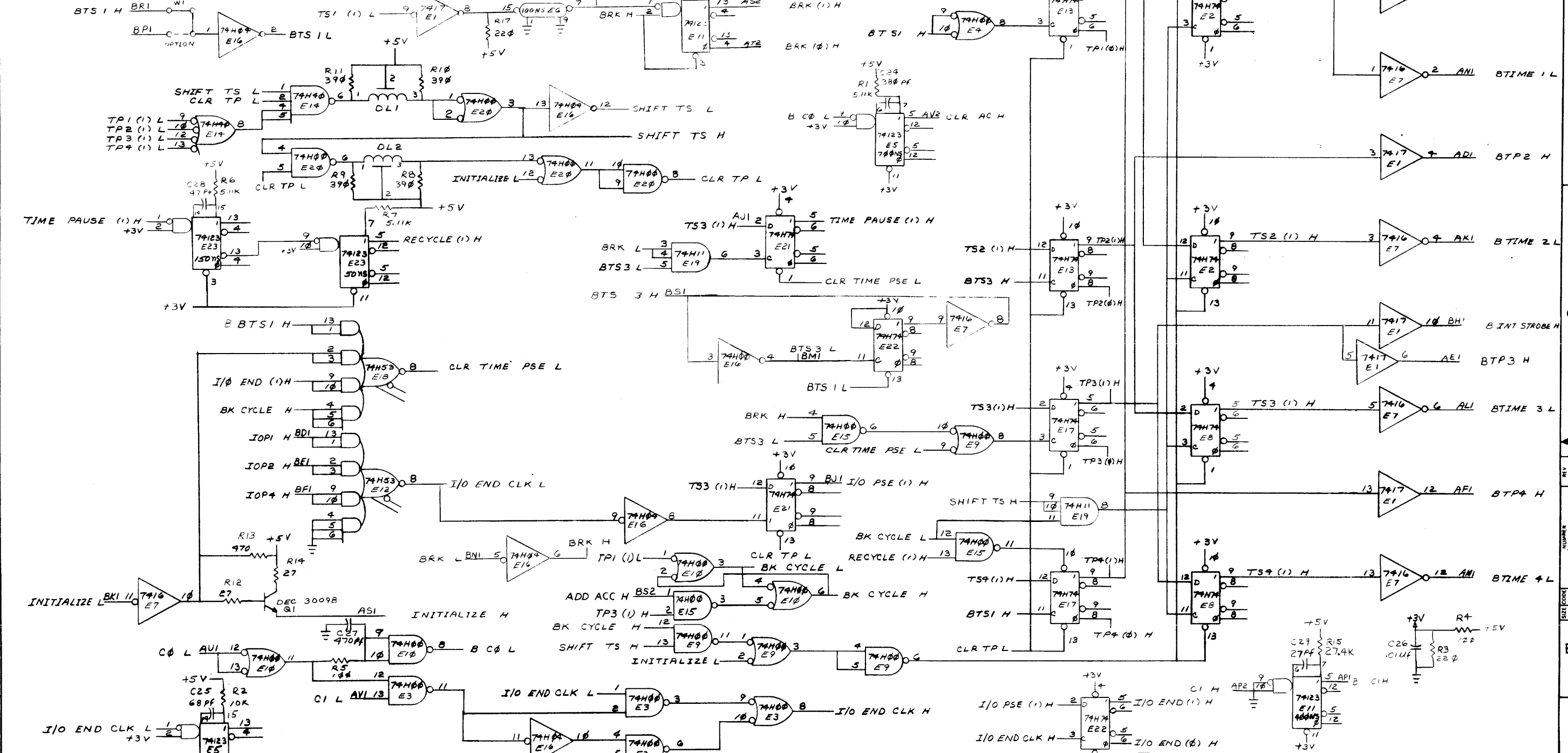

NOTE:
CHANGE W1, REMOVE W2 FOR POP-B OR LINC-B
BTS1 BECOMES MEM START
BTS3 BECOMES T1

FIRST USED ON OPTION/MODEL	QTY.	DESCRIPTION	PART NO.	ITEM NO.												
DWS-E		PARTS LIST														
UNLESS OTHERWISE SPECIFIED DIMENSION IN INCHES. TOLERANCES		<table border="1"> <tr> <td>DRN</td> <td>DATE</td> <td rowspan="5"> </td> <td rowspan="5">EQUIPMENT CORPORATION MAYNARD MASSACHUSETTS</td> </tr> <tr> <td>DESIGN</td> <td>DATE</td> </tr> <tr> <td>ENG.</td> <td>DATE</td> </tr> <tr> <td>PROJ. ENG.</td> <td>DATE</td> </tr> <tr> <td>PROD.</td> <td>DATE</td> </tr> </table>			DRN	DATE		EQUIPMENT CORPORATION MAYNARD MASSACHUSETTS	DESIGN	DATE	ENG.	DATE	PROJ. ENG.	DATE	PROD.	DATE
DRN	DATE		EQUIPMENT CORPORATION MAYNARD MASSACHUSETTS													
DESIGN	DATE															
ENG.	DATE															
PROJ. ENG.	DATE															
PROD.	DATE															
DECIMALS	ANGLES	TITLE														
XXX - 008	± 0° 30'	CONTROL														
.XX - 02																
X - 1																
REMOVE BURRS AND BREAK SHARP CORNERS SURFACE QUALITY																
MATERIAL	NEXT HIGHER ASSY.															
FINISH	SCALE	SIZE CODE	NUMBER	REV.												
	SHEET 2 OF 2	DCS M7101-0-1		F												

REV.	CHANGE NO.	REVISIONS

REV. F
NUMBER 7101-0-1
SIZE CODE DCS M7101-0-1

This drawing and specifications herein are the property of Digital Equipment Corporation and shall not be reproduced or copied or used in whole or in part as the basis for the manufacture or sale of items without written permission. COPYRIGHT © 1972 DIGITAL EQUIPMENT CORPORATION

CS M7102-0-1

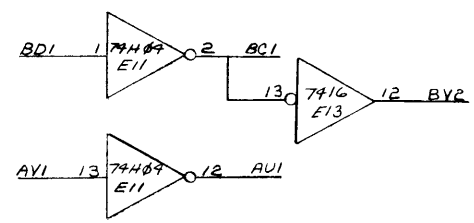
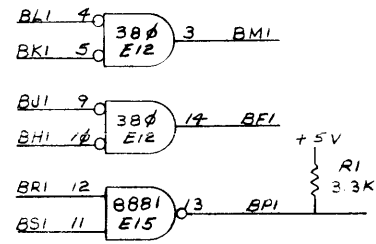
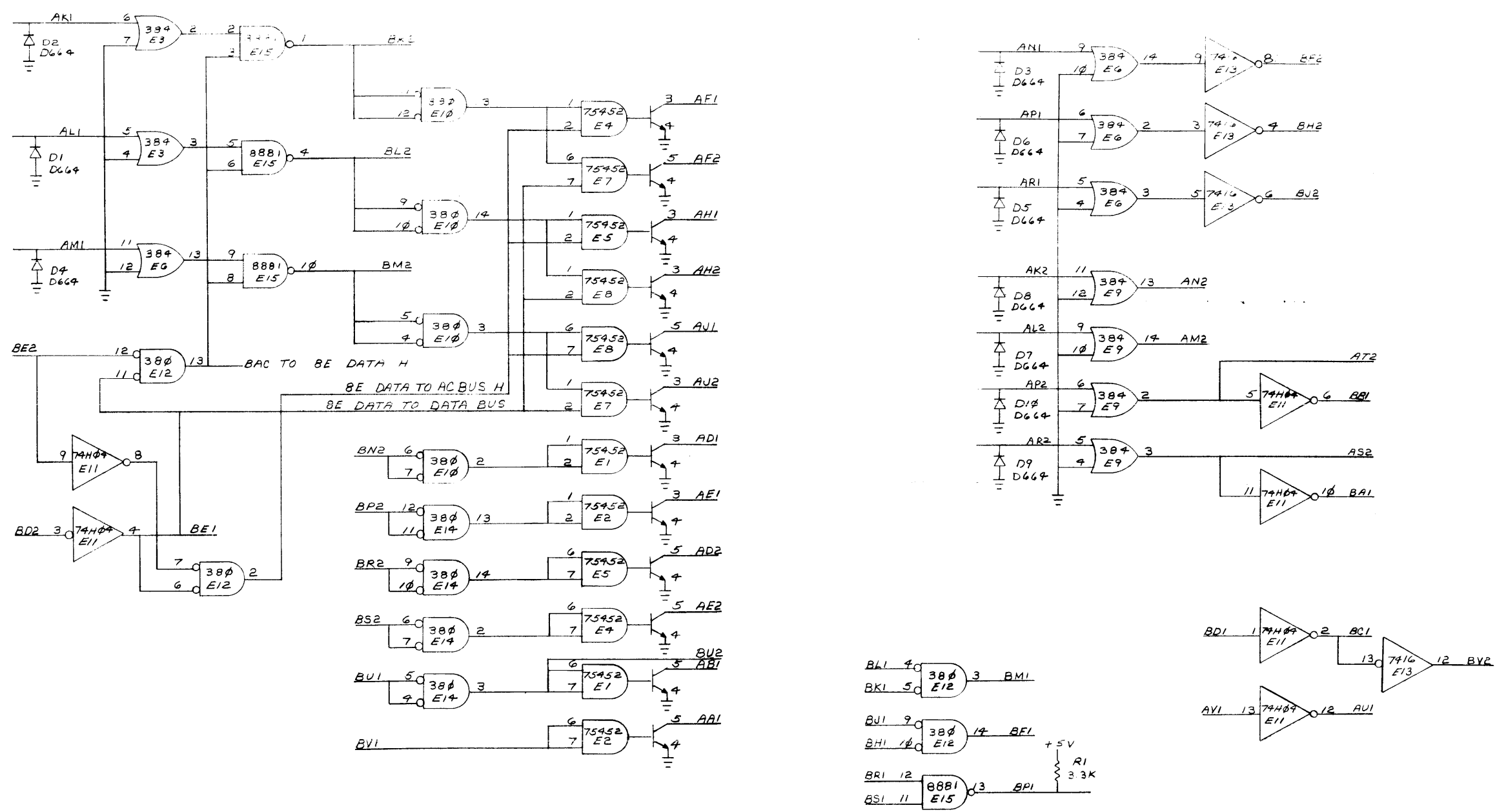

REV. NO. 1
 CHANGE NO. 1
 CHK

FIRST USED ON OPTION/MODEL	QTY.	DESCRIPTION	PART NO.	ITEM NO.
DW8-E				
PARTS LIST				
UNLESS OTHERWISE SPECIFIED DIMENSION IN INCHES TOLERANCES		DRN. <i>Wilson</i> DATE 10/19/72	 digital EQUIPMENT CORPORATION MAYNARD MASSACHUSETTS	
DECIMALS	ANGLES	CHK'D. <i>Wilson</i> DATE 3/6/73		
.XXX ± .005	± 0° 30'	ENG. <i>Wilson</i> DATE 3/8/73		
.XX ± .02		PROJ. ENG. <i>Wilson</i> DATE 3/8/73		
REMOVE BURRS AND BREAK SHARP CORNERS SURFACE QUALITY		PROD. <i>Wilson</i> DATE 4/19/73	TITLE POSITIVE I/O BUS CONVERTER	
MATERIAL	NEXT HIGHER ASSY.	SIZE CODE NUMBER		
	B-DD-DW8-E	DCS M7102-0		
FINISH	SCALE NONE	REV. C		
	SHEET 2 OF 2	DIST.		

REV. C
 NUMBER DCS M7102-0-1
 SIZE CODE D

This drawing and specifications, herein, are the property of Digital Equipment Corporation and shall not be reproduced or copied or used in whole or in part as the basis for the manufacture or sale of items without written permission. COPYRIGHT © 1973 DIGITAL EQUIPMENT CORPORATION

NOTES:

1. UNLESS OTHERWISE SPECIFIED RESISTANCE IS IN OHMS.

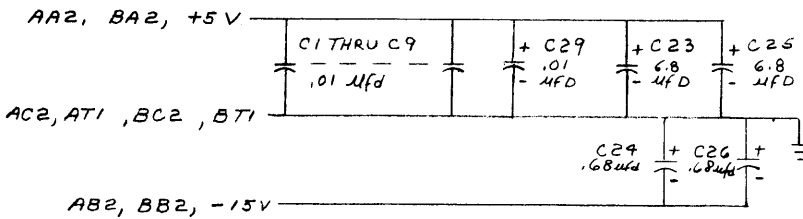
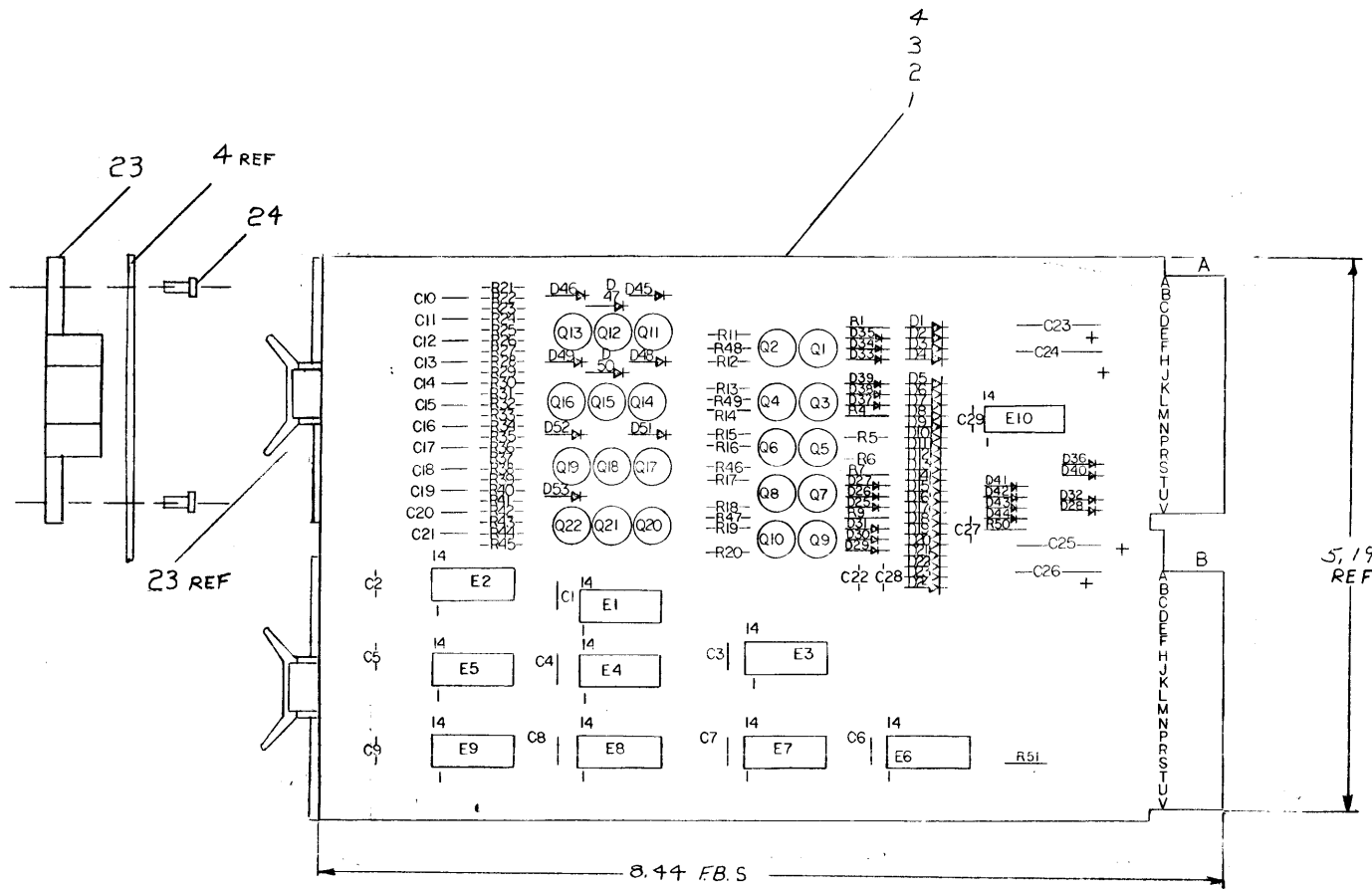

IC TYPE	GND	+5V
I.C. DEC 380	1	8
GND AND 5V ARE USUALLY PIN 7 AND 14 RESPECTIVELY. EXCEPTIONS ARE STATED ABOVE		
IC PIN LOCATIONS		

REF	DESCRIPTION	QTY	REF DESIGNATION	DESCRIPTION	PART NO.	ITEM NO.
REF	X-Y COORDINATE HOLE LOCATION		K-CO-M7103-0-1			1
REF	ASSY/DRILLING HOLE LAYOUT		D-AH-M7103-0-5			2
REF	MODULE ECO HISTORY		B-MH-M7103-0-6			3
1	ETCHED CIRCUIT BOARD	5007867				4
12	C10 THRU C21		CAP 154F 700V 5% DM		1000007	5
4	C23 THRU C26		CAP 6.8uF 35V 10% STANT		1005306	6
13	C1 THRU C9, C22, C27, C28, C29		CAP .01uF 100V 20% DISC		1001610	7
8	D21 THRU D24, D41 THRU D44		DIODE D662		1100113	8
45	D1 THRU D20, D25 THRU D40, D45-D53		DIODE D664		1100114	9
10	R1, R4 THRU R7, R9, R11, R14, R17, R19		RES. 470 1/4W 5%		1300316	10
13	R21, R23, R25, R27, R29, R31, R33, R35, R37, R39, R41, R43, R45		RES. 1K 1/4W 5%		1300365	11
10	R12, R13, R15, R16, R18, R20, R46 THRU R49		RES. 4.7K 1/4W 5%		1300447	12
12	R22, R24, R26, R28, R30, R32, R34, R36, R38, R40, R42, R44		RES. 5.6K 1/4 5%		1301874	13
1	R50		RES. 220 1/4 5%		1300271	14
1	R51		RES. 3.3K 1/4 5%		1300439	15
10	Q1 THRU Q10		TRANS. DEC 3009B		1503100	16
12	Q11 THRU Q22		TRANS. DEC 3639B		1522742-00	17
3	E4, E6, E8		I.C. DEC 380		1909485	18
1	E1		I.C. DEC 8881		1909705	19
1	E7		I.C. DEC 7416		1909928	20
2	E3, E10		I.C. DEC 74H09		1909931	21
3	E2, E5, E9		I.C. DEC 7400		1905575	22
2			HANDLE, FLIP CHIP - MAGENTA		9008337-06	23
4			EYELET (GS-4-7)		9006732	24

FIRST USED ON OPTION MODEL DW6-E		ETCH BOARD REV F		DATE 11/15/72		<p>TITLE NEGATIVE I/O BUS CONVERTER</p>
DRN	DATE	PROJ. ENG.	DATE	PROD.	DATE	
CHK'D	DATE					
ENG.	DATE					
REV	DATE					
REVISIONS		NEXT HIGHER ASSY B-DD-DNR-E		SCALE NONE		SIZE CODE DCSM7103-0-1
ED. RECD	DATE	DEC NO.	EIA NO.	DEC NO.	EIA NO.	REV. F
SEMICONDUCTOR CONVERSION CHART						SHEET 1 OF 2

BRUN. -0522 16699
DEC FORM NO. DRD-1354

REV. L
NUMBER
DCSM7103-0-1

This drawing and specifications herein are the property of Digital Equipment Corporation and shall not be reproduced or copied or used in whole or in part as the basis for the manufacture or sale of items without written permission. COPYRIGHT © 1972
DIGITAL EQUIPMENT CORPORATION

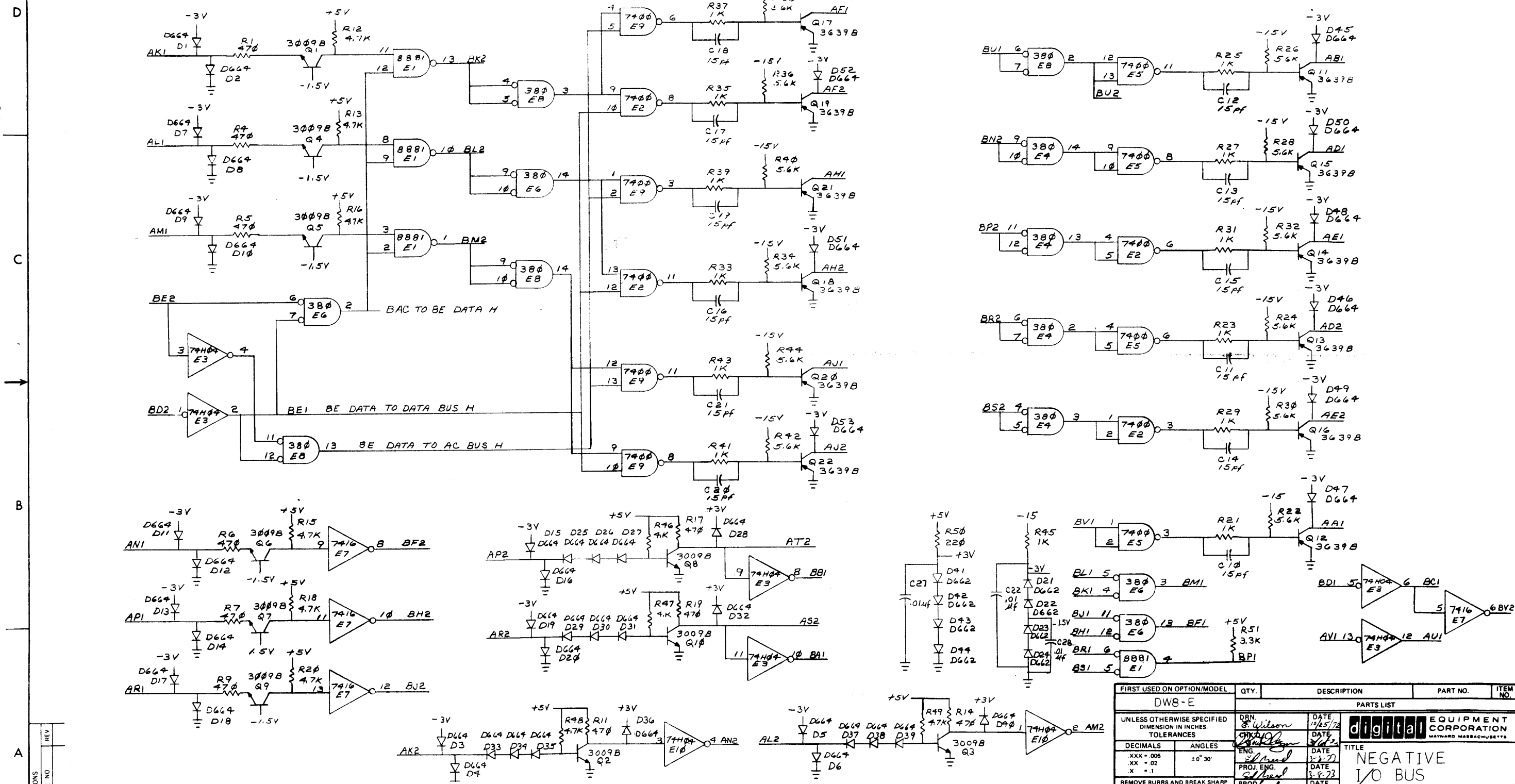

REV.	DATE	BY	CHK

FIRST USED ON OPTION/MODEL	QTY.	DESCRIPTION	PART NO.	ITEM NO.
DWB-E		PARTS LIST		
UNLESS OTHERWISE SPECIFIED DIMENSION IN INCHES. TOLERANCES				
DECIMALS	ANGLES	TITLE		
.XX + .005	± 0° 30'	NEGATIVE I/O BUS CONVERTER		
XX - .02		CORNERS SURFACE QUALITY		
X - .1		MATERIAL		
		FINISH		
		NEXT HIGHER ASSY.		
		SCALE		
		SHEET		
		DIST.		

SIZE CODE NUMBER
 DCS M7103-0-1
 REV. F

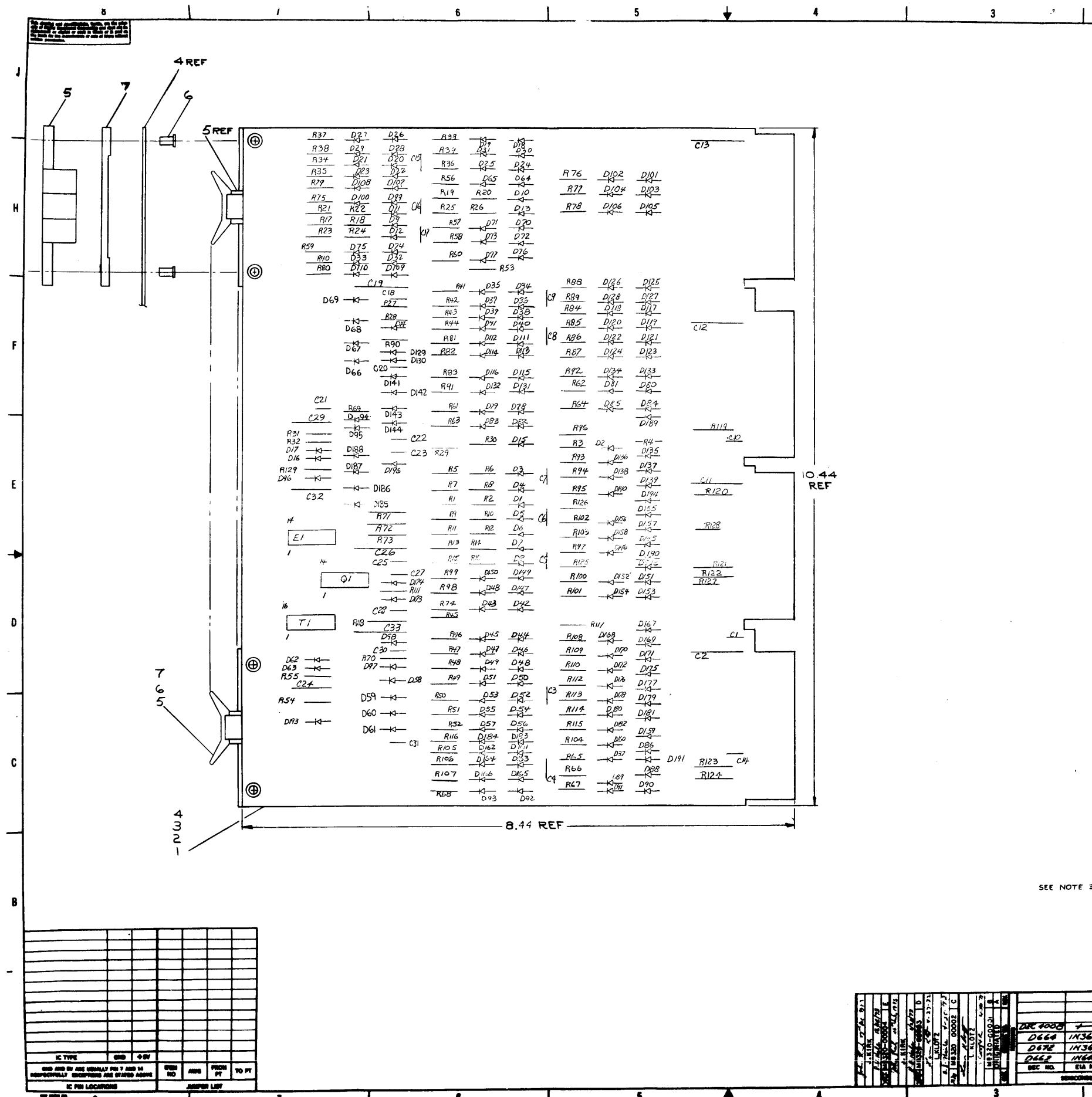

- NOTES:
- UNLESS OTHERWISE SPECIFIED:
 CAPACITORS = .047UF 16V 15-20%
 RESISTORS = 1500 1/4W 5%
 DIODES = D664
 - CONNECT ALL PINS G,F,N,T (EXCEPT AC1) TOGETHER TO GROUND.
 - ITEM NO. B (D664) MAY BE REPLACED WITH D600 P.N. 1105366 (REV C ONLY).

12	R57-R68	RES 1K 1/4 W 5%	1300365	23
13	GRIPLET		1210244-0	22
3	C24, C29, C32	CAP 330PF 100V 5%	1000023	21
7	C2, C11, C12, C13, C19, C26, C33	CAP 6.8UF 35V 20%	1000067	20
23	C13-C10, C14-C16, C20-C23, C25, C27, C28, C30, C31	CAP .047UF 16V 15-20%	1009678	19
1	27	IC DEC 7805	1827777	18
1	31	RES 1K 1/4 W 5%	1404551	17
1	Q1	TRANS DEC 400A	150018	16
6	R19-E124	RES 1K 1/4 W 10%	1302187	15
4	R71-R73, E10	RES 1.2K 1/4 W 10%	1300387	14
4	R53, E69, E74-E117	RES 1500 1/4 W 5%	1300391	13
41	R22, R24, R26, R28, R30, R32-E35, E35, E54, E70, E72, E128	RES 470 1/4 W 10%	1300311	12
20	R1, R23, E77, E10, E12, E15, E17, E19, E45, E52, E55, E77, E79, E83, E84, E85, E86, E87	RES 150 1/4 W 5%	1300250	11
2	D17, D97	DIODE D672	1102275	10
16	D58-D61, D66-D68, D71-D74, D76-D77, D83-D85, D104, D109, D194, D196	DIODE D662	1100113	9
77	D65, D70-D74, D86-D90, D95-D104, D107, D194, D196	DIODE D664	1100114	8
4		SPACER (CABLE CLAMP)	1102704	7
8		STRETCHER STIMPSON	1000750	6
4		WASHER FLIP CHIP-MAGENTA	1000337-06	5
4		WASHER CIRCUIT BOARD	1007486	4
1		MODULE HISTORY LIST	8-MH-1032-04	3
107		ASSY/DRILLING HOLE LAYOUT	D-UA-KAB-E-D	2
107		P.Y. COORDINATE HOLE LOC.	K-CO-1032-04	1

SEE NOTE 3

IC TYPE	QND	QDV	QDR	QDS	QDT	QDU	QDV
QND	QND	QND	QND	QND	QND	QND	QND
QDV	QDV	QDV	QDV	QDV	QDV	QDV	QDV
QDR	QDR	QDR	QDR	QDR	QDR	QDR	QDR
QDS	QDS	QDS	QDS	QDS	QDS	QDS	QDS
QDT	QDT	QDT	QDT	QDT	QDT	QDT	QDT
QDU	QDU	QDU	QDU	QDU	QDU	QDU	QDU
QDV	QDV	QDV	QDV	QDV	QDV	QDV	QDV

DATE	10/10/68	BY	J. L. ...
REV	1	DESCRIPTION	...
REV	2	DESCRIPTION	...
REV	3	DESCRIPTION	...
REV	4	DESCRIPTION	...
REV	5	DESCRIPTION	...
REV	6	DESCRIPTION	...
REV	7	DESCRIPTION	...
REV	8	DESCRIPTION	...
REV	9	DESCRIPTION	...
REV	10	DESCRIPTION	...
REV	11	DESCRIPTION	...
REV	12	DESCRIPTION	...
REV	13	DESCRIPTION	...
REV	14	DESCRIPTION	...
REV	15	DESCRIPTION	...
REV	16	DESCRIPTION	...
REV	17	DESCRIPTION	...
REV	18	DESCRIPTION	...
REV	19	DESCRIPTION	...
REV	20	DESCRIPTION	...
REV	21	DESCRIPTION	...
REV	22	DESCRIPTION	...
REV	23	DESCRIPTION	...
REV	24	DESCRIPTION	...
REV	25	DESCRIPTION	...
REV	26	DESCRIPTION	...
REV	27	DESCRIPTION	...
REV	28	DESCRIPTION	...
REV	29	DESCRIPTION	...
REV	30	DESCRIPTION	...

ETCH BOARD REV	D									
DATE	10/10/68	BY	J. L. ...							
REV	1	DESCRIPTION	...							
REV	2	DESCRIPTION	...							
REV	3	DESCRIPTION	...							
REV	4	DESCRIPTION	...							
REV	5	DESCRIPTION	...							
REV	6	DESCRIPTION	...							
REV	7	DESCRIPTION	...							
REV	8	DESCRIPTION	...							
REV	9	DESCRIPTION	...							
REV	10	DESCRIPTION	...							
REV	11	DESCRIPTION	...							
REV	12	DESCRIPTION	...							
REV	13	DESCRIPTION	...							
REV	14	DESCRIPTION	...							
REV	15	DESCRIPTION	...							
REV	16	DESCRIPTION	...							
REV	17	DESCRIPTION	...							
REV	18	DESCRIPTION	...							
REV	19	DESCRIPTION	...							
REV	20	DESCRIPTION	...							
REV	21	DESCRIPTION	...							
REV	22	DESCRIPTION	...							
REV	23	DESCRIPTION	...							
REV	24	DESCRIPTION	...							
REV	25	DESCRIPTION	...							
REV	26	DESCRIPTION	...							
REV	27	DESCRIPTION	...							
REV	28	DESCRIPTION	...							
REV	29	DESCRIPTION	...							
REV	30	DESCRIPTION	...							

BUS LOADS

D-UA-KAB-E-D	10/10/68	J. L. ...								
REV	1	DESCRIPTION	...							
REV	2	DESCRIPTION	...							
REV	3	DESCRIPTION	...							
REV	4	DESCRIPTION	...							
REV	5	DESCRIPTION	...							
REV	6	DESCRIPTION	...							
REV	7	DESCRIPTION	...							
REV	8	DESCRIPTION	...							
REV	9	DESCRIPTION	...							
REV	10	DESCRIPTION	...							
REV	11	DESCRIPTION	...							
REV	12	DESCRIPTION	...							
REV	13	DESCRIPTION	...							
REV	14	DESCRIPTION	...							
REV	15	DESCRIPTION	...							
REV	16	DESCRIPTION	...							
REV	17	DESCRIPTION	...							
REV	18	DESCRIPTION	...							
REV	19	DESCRIPTION	...							
REV	20	DESCRIPTION	...							
REV	21	DESCRIPTION	...							
REV	22	DESCRIPTION	...							
REV	23	DESCRIPTION	...							
REV	24	DESCRIPTION	...							
REV	25	DESCRIPTION	...							
REV	26	DESCRIPTION	...							
REV	27	DESCRIPTION	...							
REV	28	DESCRIPTION	...							
REV	29	DESCRIPTION	...							
REV	30	DESCRIPTION	...							

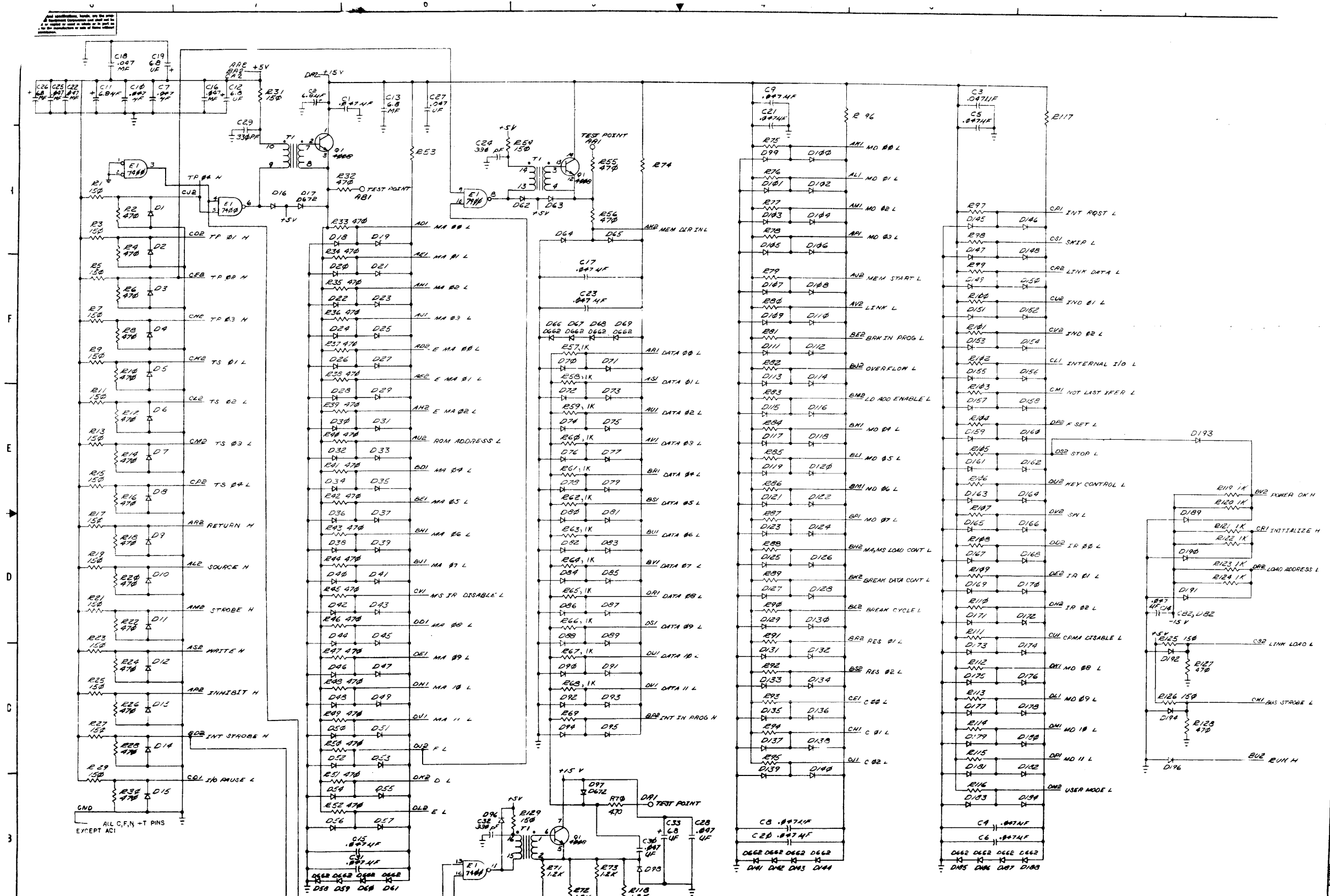

QTY.	DESCRIPTION	PART NO.	ITEM NO.
1	RESISTOR 150 OHMS	R1	1
1	RESISTOR 150 OHMS	R2	2
1	RESISTOR 150 OHMS	R3	3
1	RESISTOR 150 OHMS	R4	4
1	RESISTOR 150 OHMS	R5	5
1	RESISTOR 150 OHMS	R6	6
1	RESISTOR 150 OHMS	R7	7
1	RESISTOR 150 OHMS	R8	8
1	RESISTOR 150 OHMS	R9	9
1	RESISTOR 150 OHMS	R10	10
1	RESISTOR 150 OHMS	R11	11
1	RESISTOR 150 OHMS	R12	12
1	RESISTOR 150 OHMS	R13	13
1	RESISTOR 150 OHMS	R14	14
1	RESISTOR 150 OHMS	R15	15
1	RESISTOR 150 OHMS	R16	16
1	RESISTOR 150 OHMS	R17	17
1	RESISTOR 150 OHMS	R18	18
1	RESISTOR 150 OHMS	R19	19
1	RESISTOR 150 OHMS	R20	20
1	RESISTOR 150 OHMS	R21	21
1	RESISTOR 150 OHMS	R22	22
1	RESISTOR 150 OHMS	R23	23
1	RESISTOR 150 OHMS	R24	24
1	RESISTOR 150 OHMS	R25	25
1	RESISTOR 150 OHMS	R26	26
1	RESISTOR 150 OHMS	R27	27
1	RESISTOR 150 OHMS	R28	28
1	RESISTOR 150 OHMS	R29	29
1	RESISTOR 150 OHMS	R30	30
1	DIODE 1N4001	D1	1
1	DIODE 1N4001	D2	2
1	DIODE 1N4001	D3	3
1	DIODE 1N4001	D4	4
1	DIODE 1N4001	D5	5
1	DIODE 1N4001	D6	6
1	DIODE 1N4001	D7	7
1	DIODE 1N4001	D8	8
1	DIODE 1N4001	D9	9
1	DIODE 1N4001	D10	10
1	DIODE 1N4001	D11	11
1	DIODE 1N4001	D12	12
1	DIODE 1N4001	D13	13
1	DIODE 1N4001	D14	14
1	DIODE 1N4001	D15	15
1	DIODE 1N4001	D18	18
1	DIODE 1N4001	D19	19
1	DIODE 1N4001	D20	20
1	DIODE 1N4001	D21	21
1	DIODE 1N4001	D22	22
1	DIODE 1N4001	D23	23
1	DIODE 1N4001	D24	24
1	DIODE 1N4001	D25	25
1	DIODE 1N4001	D26	26
1	DIODE 1N4001	D27	27
1	DIODE 1N4001	D28	28
1	DIODE 1N4001	D29	29
1	DIODE 1N4001	D30	30
1	DIODE 1N4001	D31	31
1	DIODE 1N4001	D32	32
1	DIODE 1N4001	D33	33
1	DIODE 1N4001	D34	34
1	DIODE 1N4001	D35	35
1	DIODE 1N4001	D36	36
1	DIODE 1N4001	D37	37
1	DIODE 1N4001	D38	38
1	DIODE 1N4001	D39	39
1	DIODE 1N4001	D40	40
1	DIODE 1N4001	D41	41
1	DIODE 1N4001	D42	42
1	DIODE 1N4001	D43	43
1	DIODE 1N4001	D44	44
1	DIODE 1N4001	D45	45
1	DIODE 1N4001	D46	46
1	DIODE 1N4001	D47	47
1	DIODE 1N4001	D48	48
1	DIODE 1N4001	D49	49
1	DIODE 1N4001	D50	50
1	DIODE 1N4001	D51	51
1	DIODE 1N4001	D52	52
1	DIODE 1N4001	D53	53
1	DIODE 1N4001	D54	54
1	DIODE 1N4001	D55	55
1	DIODE 1N4001	D56	56
1	DIODE 1N4001	D57	57
1	DIODE 1N4001	D97	97
1	DIODE 1N4001	D98	98
1	DIODE 1N4001	D99	99
1	DIODE 1N4001	D100	100
1	DIODE 1N4001	D101	101
1	DIODE 1N4001	D102	102
1	DIODE 1N4001	D103	103
1	DIODE 1N4001	D104	104
1	DIODE 1N4001	D105	105
1	DIODE 1N4001	D106	106
1	DIODE 1N4001	D107	107
1	DIODE 1N4001	D108	108
1	DIODE 1N4001	D109	109
1	DIODE 1N4001	D110	110
1	DIODE 1N4001	D111	111
1	DIODE 1N4001	D112	112
1	DIODE 1N4001	D113	113
1	DIODE 1N4001	D114	114
1	DIODE 1N4001	D115	115
1	DIODE 1N4001	D116	116
1	DIODE 1N4001	D117	117
1	DIODE 1N4001	D118	118
1	DIODE 1N4001	D119	119
1	DIODE 1N4001	D120	120
1	DIODE 1N4001	D121	121
1	DIODE 1N4001	D122	122
1	DIODE 1N4001	D123	123
1	DIODE 1N4001	D124	124
1	DIODE 1N4001	D125	125
1	DIODE 1N4001	D126	126
1	DIODE 1N4001	D127	127
1	DIODE 1N4001	D128	128
1	DIODE 1N4001	D129	129
1	DIODE 1N4001	D130	130
1	DIODE 1N4001	D131	131
1	DIODE 1N4001	D132	132
1	DIODE 1N4001	D133	133
1	DIODE 1N4001	D134	134
1	DIODE 1N4001	D135	135
1	DIODE 1N4001	D136	136
1	DIODE 1N4001	D137	137
1	DIODE 1N4001	D138	138
1	DIODE 1N4001	D139	139
1	DIODE 1N4001	D140	140
1	DIODE 1N4001	D141	141
1	DIODE 1N4001	D142	142
1	DIODE 1N4001	D143	143
1	DIODE 1N4001	D144	144
1	DIODE 1N4001	D145	145
1	DIODE 1N4001	D146	146
1	DIODE 1N4001	D147	147
1	DIODE 1N4001	D148	148
1	DIODE 1N4001	D149	149
1	DIODE 1N4001	D150	150
1	DIODE 1N4001	D151	151
1	DIODE 1N4001	D152	152
1	DIODE 1N4001	D153	153
1	DIODE 1N4001	D154	154
1	DIODE 1N4001	D155	155
1	DIODE 1N4001	D156	156
1	DIODE 1N4001	D157	157
1	DIODE 1N4001	D158	158
1	DIODE 1N4001	D159	159
1	DIODE 1N4001	D160	160
1	DIODE 1N4001	D161	161
1	DIODE 1N4001	D162	162
1	DIODE 1N4001	D163	163
1	DIODE 1N4001	D164	164
1	DIODE 1N4001	D165	165
1	DIODE 1N4001	D166	166
1	DIODE 1N4001	D167	167
1	DIODE 1N4001	D168	168
1	DIODE 1N4001	D169	169
1	DIODE 1N4001	D170	170
1	DIODE 1N4001	D171	171
1	DIODE 1N4001	D172	172
1	DIODE 1N4001	D173	173
1	DIODE 1N4001	D174	174
1	DIODE 1N4001	D175	175
1	DIODE 1N4001	D176	176
1	DIODE 1N4001	D177	177
1	DIODE 1N4001	D178	178
1	DIODE 1N4001	D179	179
1	DIODE 1N4001	D180	180
1	DIODE 1N4001	D181	181
1	DIODE 1N4001	D182	182
1	DIODE 1N4001	D183	183
1	DIODE 1N4001	D184	184
1	DIODE 1N4001	D185	185
1	DIODE 1N4001	D186	186
1	DIODE 1N4001	D187	187
1	DIODE 1N4001	D188	188
1	DIODE 1N4001	D189	189
1	DIODE 1N4001	D190	190
1	DIODE 1N4001	D191	191
1	DIODE 1N4001	D192	192
1	DIODE 1N4001	D193	193

100% TESTED
 100% INSULATED
 100% CHECKED
 100% APPROVED
 100% SHIPPED

BUS LOADS

EKS M8320-0-1
 100% TESTED
 100% INSULATED
 100% CHECKED
 100% APPROVED
 100% SHIPPED

This drawing and specifications, herein, are the property of Digital Equipment Corporation and shall not be reproduced or copied or used in whole or in part as the basis for the manufacture or sale of items without written permission. COPYRIGHT © 1973 DIGITAL EQUIPMENT CORPORATION

WIRE TABLE							
ITEM NO.	DESCRIPTION	FROM:			TO:		
		AWG	COLOR	CONNECTION WITH	CONNECTION WITH		
9	BLU	XMER	-	J1-3	12	LENGTH OF WIRE TO BE 14 IN. ± 1/2 IN. (REF ONLY)	
	BLU		-	J1-2	12		
	BLK		-	J1-1	12		
	RED		-	PI-3	13		
	RED		-	PI-4	13		
9	WHT		-	PI-1	13	LENGTH OF WIRES TO BE 6 IN. ± 1/2 IN. (REF ONLY)	
	BLK	XMER	-	PI-2	13		
22	18	GRN	XMER	SOLDER	-		21
22	18	GRN	PI-5	13	-		21

NOTES:
 1. LENGTH OF WIRES TERMINATING TO PI (ITEM 2) ARE TO BE 8 INCHES ± 1/2 INCH.
 2. COMPONENTS J1 & PI, TO BE LABELED WITH COMPONENT IDENTIFIERS, USING BRADY MARKERS.

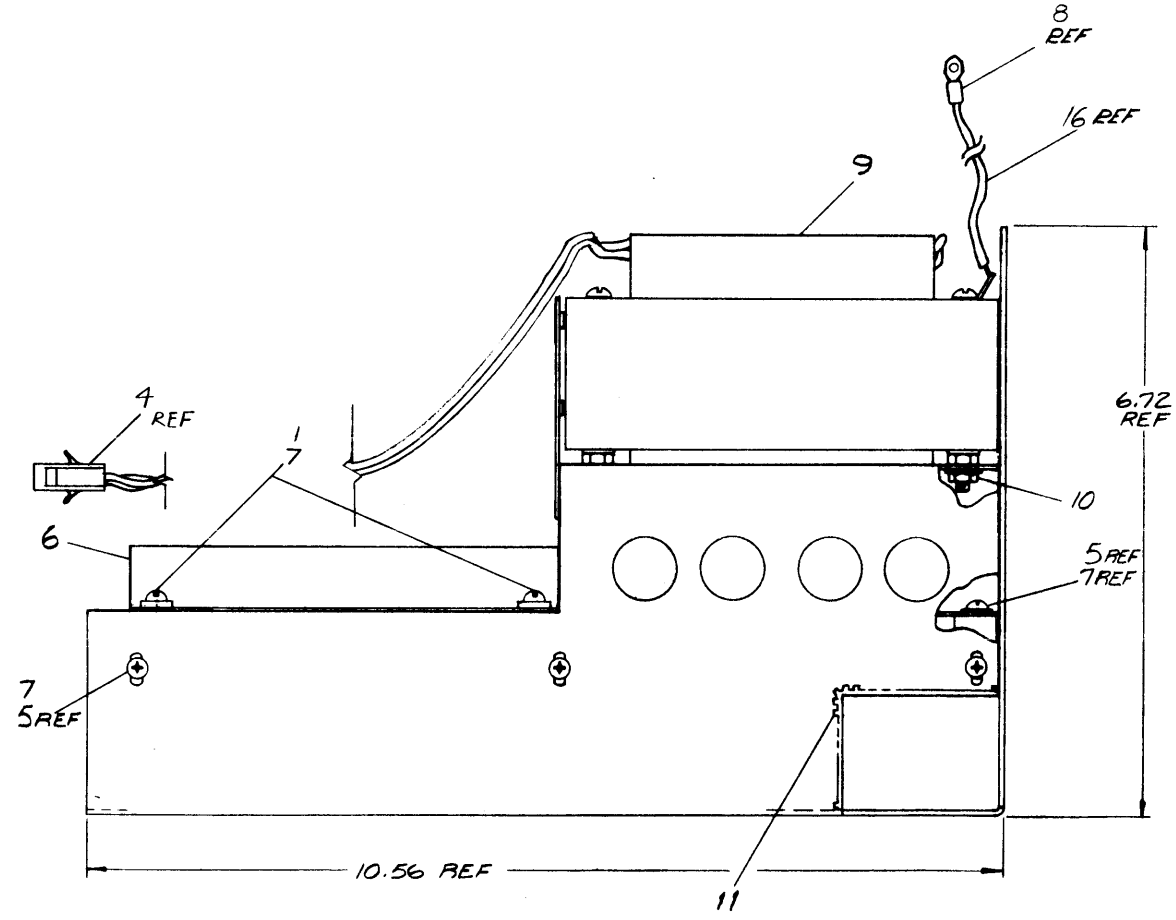
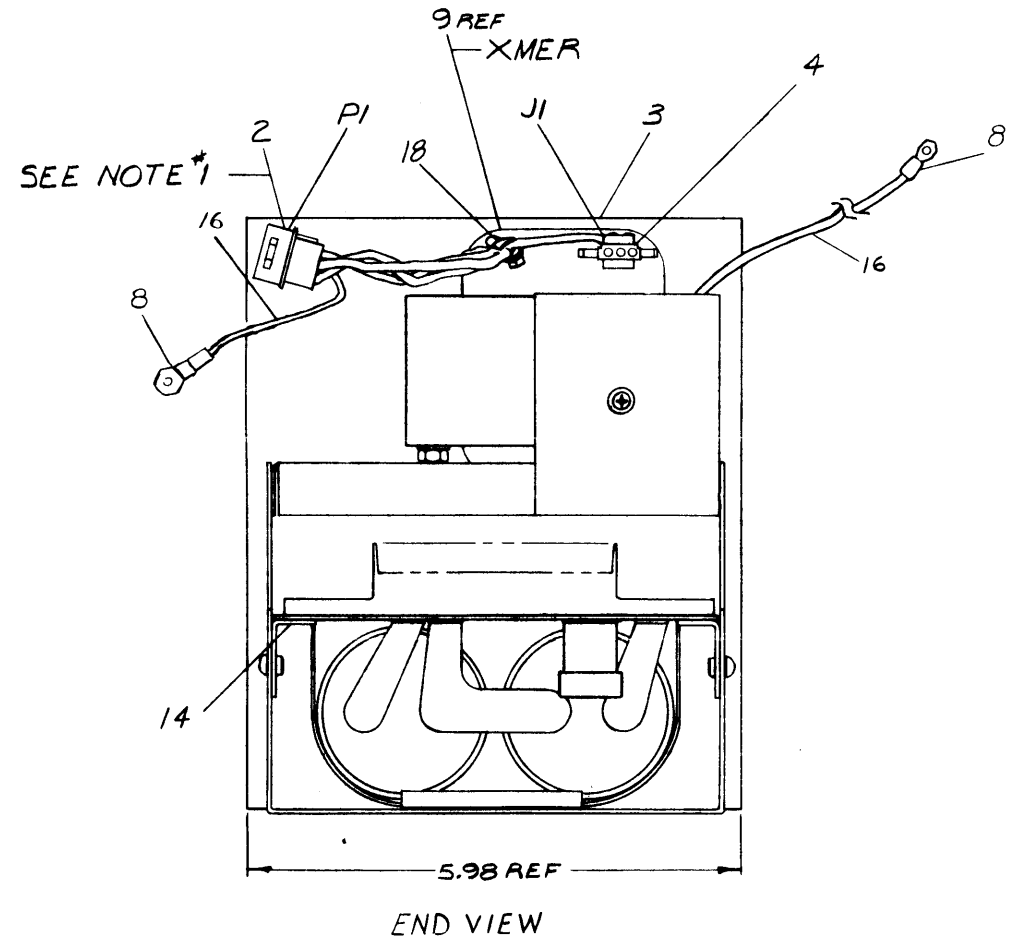

QTY.	DESCRIPTION	PART NO.	ITEM NO.
1	TIE WRAP RADUT SST-18	9007031	18
A/R	WIRE 18AWG BLK	9107360-00	17
A/R	WIRE 18AWG GRN	9107360-55	16
1	STRAIN, RELIEF	9008442	15
6	BRKT, SUPPORT ETCH BD	61A-709325-00	14
5	CONTACT, MATE-N-LOK (MALE)	1209378-01	13
3	CONTACT, MATE-N-LOK (FEM)	1209379-01	12
A/R	GROMMET	9007621	11
4	NUT, KEP #8-32	9006563	10
1	XMER (TRANSFORMER)	1610601-02	9
2	TERMINAL SOLDERLESS	9007929	8
12	WASHER, INT TOOTH LOCK #6	9006693	7
1	REGULATOR BD ASSY	61A-5409285-0	6
8	SCR, PHIL PAN HD #6-32 X.25	9006020-1	5
1	CONN, MATE-N-LOK 3CKT	1209350-08	4
1	CHASSIS, P.S.	61A-709376-00	3
1	CONN, MATE-N-LOK 6CKT	1209351-06	2
4	SCR, PHIL PAN HD #6-32 X.50	9006024-1	1

CAUTION
 CHANGE COULD AFFECT U.L. LISTING

FIRST USED ON OPTION/MODEL		DATE		PARTS LIST	
DW8-E		DATE		PARTS LIST	
UNLESS OTHERWISE SPECIFIED DIMENSION IN INCHES TOLERANCES		DRN	DATE	digital EQUIPMENT CORPORATION	
DECIMALS	ANGLES	CHK'D	DATE	MAYNARD MASSACHUSETTS	
.XXX - .006	10° 30'	ENG	DATE	TITLE	
.XX - .02		PROL'NG	DATE	POWER SUPPLY ASSY	
.X - .1		PROD.	DATE	SIZE CODE NUMBER REV	
REMOVE BURRS AND BREAK SHARP CORNERS SURFACE QUALITY		DATE		D-LA-DW8-E-0	
MATERIAL		NEXT HIGHER ASSY.		D AD 7009287-0-0	
FINISH		SCALE		SHEET 1 OF 1	
		OF 1		DIST.	

REV	CHANGE NO

This drawing and specifications, herein, are the property of Digital Equipment Corporation and shall not be reproduced or copied or used in whole or in part as the basis for the manufacture or sale of items without written permission.

5409728-0-1

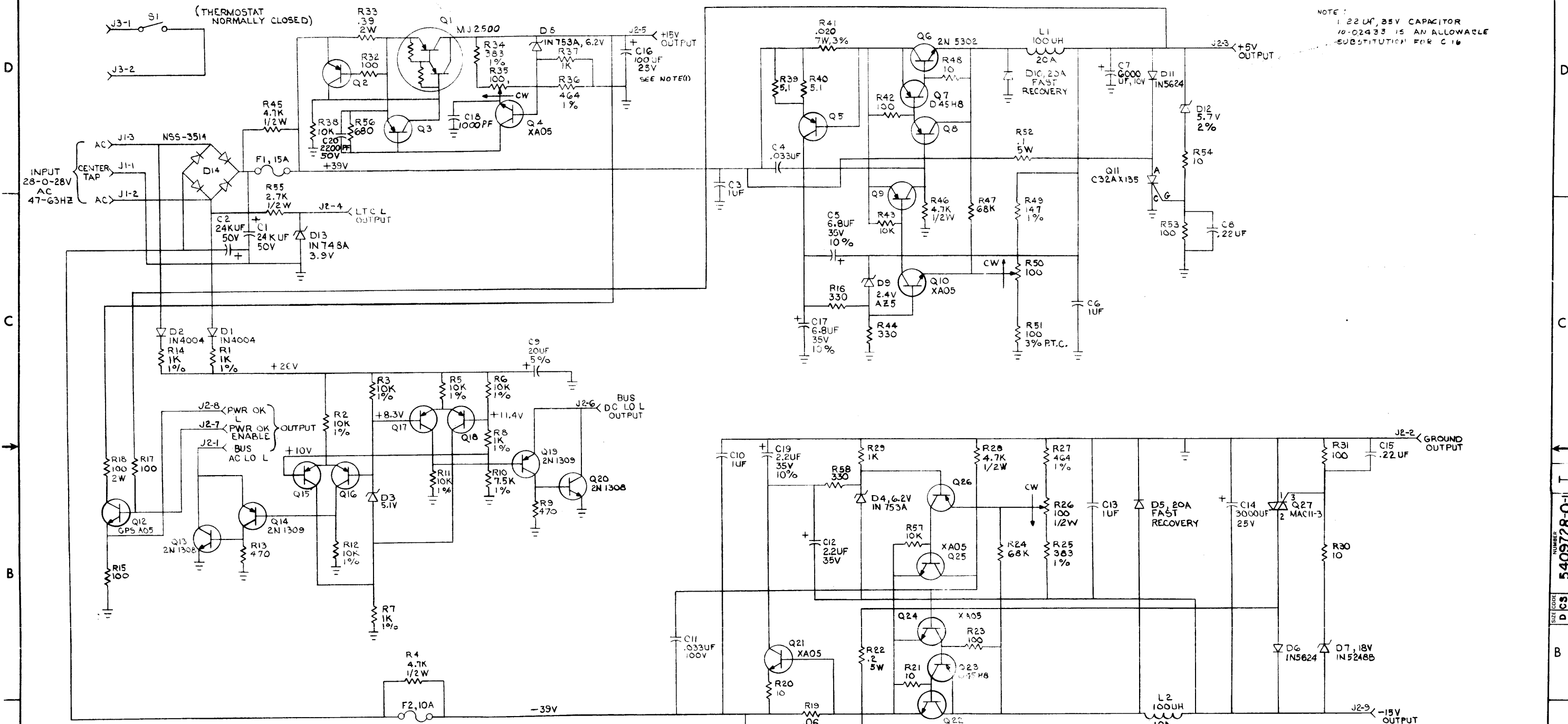

NOTE:
1. 22UF, 35V CAPACITOR
10-02933 IS AN ALLOWABLE
SUBSTITUTION FOR C16

UNLESS OTHERWISE INDICATED:
1% RESISTORS ARE 1/8W
VOLTAGES ARE TAKEN AT NO LOAD WITH 115 VAC LINE
VOLTAGES ARE ±10% TAKEN BY A ≥ 10KV METER
TRANSISTORS = XA55

REV	DATE	BY	CHK	DESCRIPTION
1	12-20-71	D. MARTEL		INITIAL DESIGN
2	1-21-72	JIM BRAY		REVISED FOR MANUFACTURE
3	12-25-71	B. WOLFF		REVISED FOR MANUFACTURE
4	1-25-72	R. BURTON		REVISED FOR MANUFACTURE
5	1-25-72	R. BURTON		REVISED FOR MANUFACTURE
6	1-25-72	R. BURTON		REVISED FOR MANUFACTURE
7	1-25-72	R. BURTON		REVISED FOR MANUFACTURE
8	1-25-72	R. BURTON		REVISED FOR MANUFACTURE

QTY	REF DESIGNATION	DESCRIPTION	PART NO.	ITEM NO.
PARTS LIST				
ETCH BOARD REV E				
DRN. POWER		DATE 12-20-71	digital EQUIPMENT CORPORATION MAYNARD, MASSACHUSETTS	
CHK'D. NANCY MOORE		DATE 1-21-72	TITLE REGULATOR BOARD FOR H740	
ENG. P. ...		DATE 12-25-71	SIZE CODE DCS NUMBER 5409728-0-1 REV. T	
PROJ. ENG. ...		DATE 12-25-71	SCALE	
PROD. ...		DATE 12-25-71	SHEET OF	
NEXT HIGHER ASSY		SEMICONDUCTOR CONVERSION CHART		

This drawing and specifications, herein, are the property of Digital Equipment Corporation and shall not be reproduced or copied or used in whole or in part as the basis for the manufacture or sale of items without written permission. 1972

NOTES:

- CONNECT ITEM #1 (POWER CORD) AND ITEM #2 (AC INPUT BOX) PER CIRCUIT SCHEMATIC.
- FOR INSTALLATION USE HEYCO #29 STRAIN RELIEF PLIERS

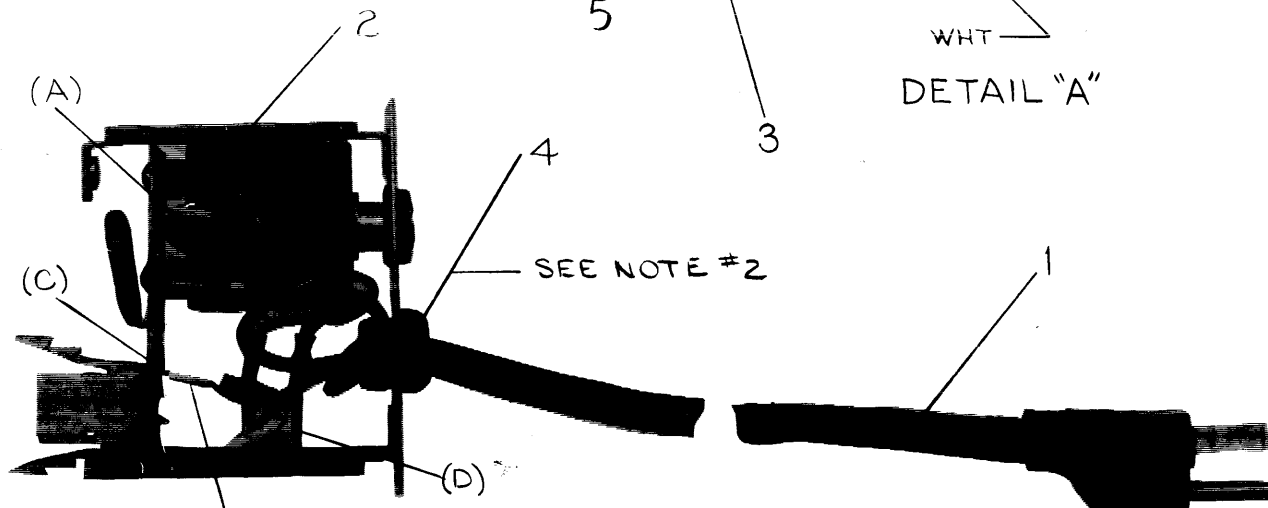
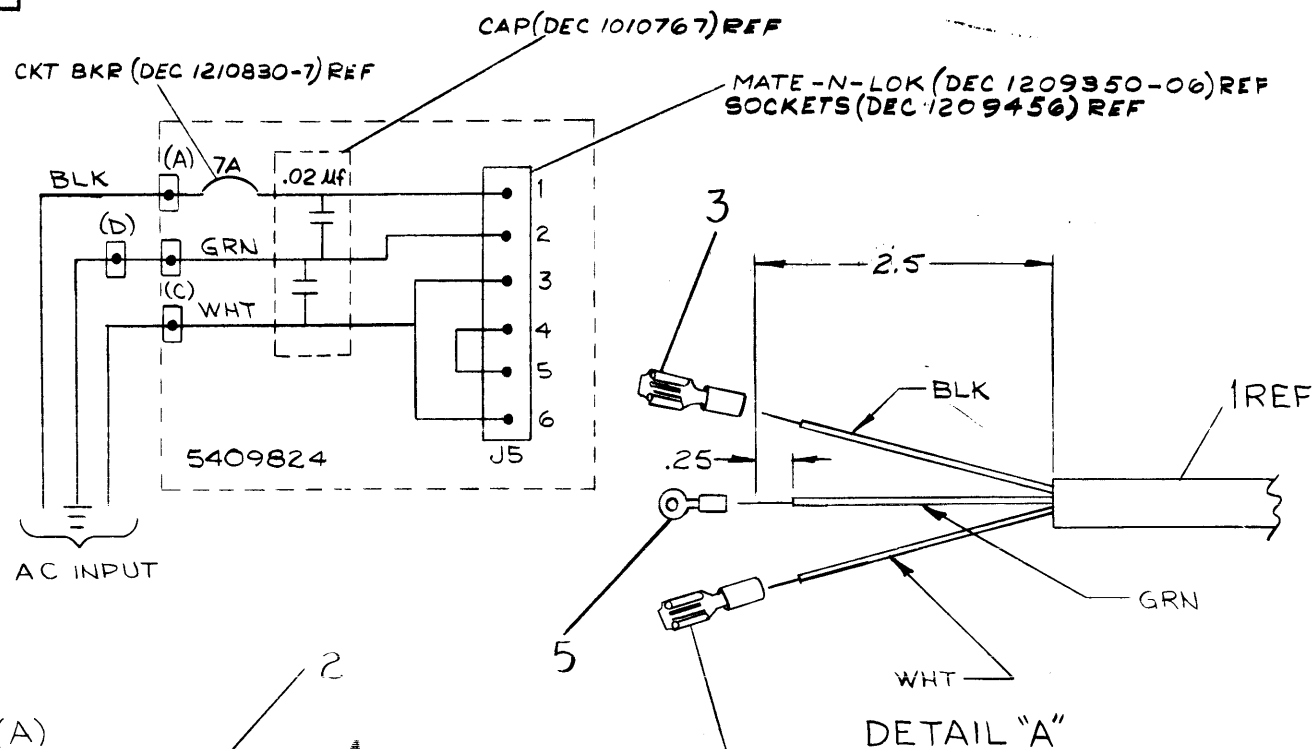

SEE DETAIL 'A'
3 REF
SHOWN WITHOUT COVER

QTY.	DESCRIPTION	PART NO.	ITEM NO.
1	SOLDER CONN ARKLESS	9007929-0	3
1	STRAIN RELIEF SR-6N3-4	9008492-2	4
2	SOLDERLESS CONN. ARKLESS	9007919	3
1	AC INPUT BOX H400A	D-UA-H400-0-0	2
1	POWER CORD 120V	170015-6	1

REV.	CHANGE NO.	CHK
A	00001	R. WOLFF
B	00002	R. BURTON
C	00002	R. BURTON
D	00003	R. BURTON
E	00003	R. BURTON

FIRST USED ON OPTION/MODEL	QTY.	DESCRIPTION	PART NO.	ITEM NO.
11/05				
UNLESS OTHERWISE SPECIFIED DIMENSION IN INCHES. TOLERANCES				
DECIMALS	ANGLES			
XXX = .005	±0° 30'			
XX = .02				
X = .1				
REMOVE BURRS AND BREAK SHARP CORNERS SURFACE QUALITY ✓				
MATERIAL	NEXT HIGHER ASSY.			
FINISH	SCALE			
	SHEET 1 OF 1			
PARTS LIST			TITLE	
DRN. T. Guillin DATE 12-27-71			digital EQUIPMENT CORPORATION	
CHKD. DATE 1-9-72			MAYNARD MASSACHUSETTS	
ENG. David DeMunillo DATE 1-4-72			LINE SET	
PROJ. ENG. DATE 1-7-72			115VAC 7AMP	
PROD. R. K. Pitarone DATE 1/2/72				
SIZE CODE	NUMBER		REV.	
C UA	BC05H-0-0			
DIST.	G			

This drawing and specifications, herein, are the property of Digital Equipment Corporation and shall not be reproduced or copied or used in whole or in part as the basis for the manufacture or sale of items without written permission. 1972

NOTES:

- CONNECT ITEM #1 (POWER CORD) AND ITEM #2 (AC INPUT) PER CIRCUIT SCHEMATIC.
- FOR INSTALLATION USE HAYCO #29 STRAIN RELIEF PLIERS.

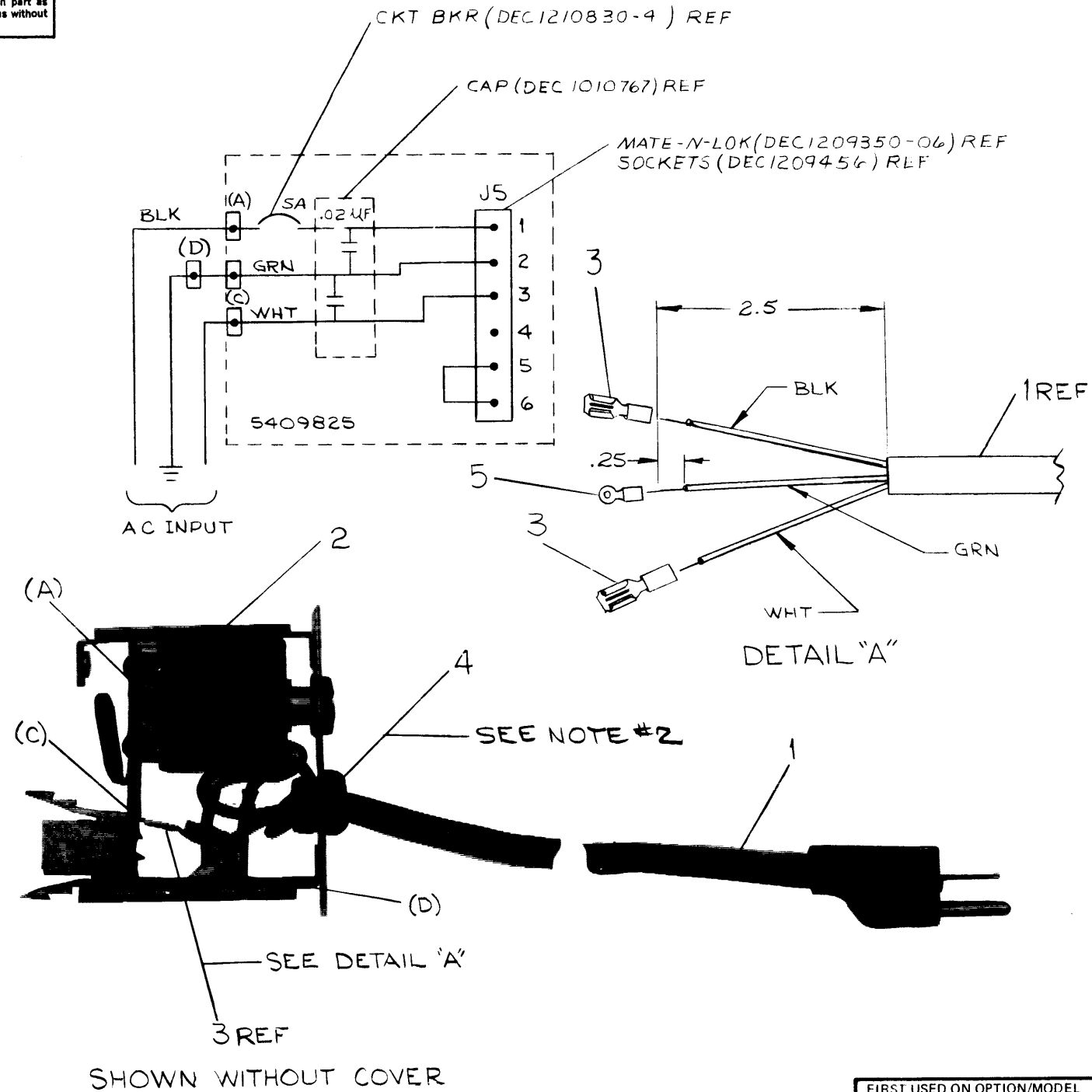

REV.	CHANGE NO.	DATE	BY	CHKD.
A	BC05J-00001	2-7-72	WOLFF	
B	H400-00002	2-8-72	R. BURTON	
C	BC05J-00002	5-25-72	R. BURTON	
D	BC05J-00003	11-2-72	R. BURTON	
		12-20-72	R. BURTON	
		1-2-73	R. BURTON	

QTY.	DESCRIPTION	PART NO.	ITEM NO.
1	SOLDER CONN ARKLESS	9007929-0	5
1	GROMMET HEYCO SR-6N3-4	9008492-2	4
2	SOLDER CONN ARKLESS	9007919	3
1	AC INPUT BOX H400 B	DUA-H400-0-0	2
1	POWER CORD 240V	1700016-6	1

FIRST USED ON OPTION/MODEL 11/05	PARTS LIST	
UNLESS OTHERWISE SPECIFIED DIMENSION IN INCHES. TOLERANCES	DBN: T. Guillon CHKD: J. Lantieri ENG: David De Marco PROJ. ENG: R. H. Heston PROD: R. R. Peterson	DATE: 12-27-71 DATE: 1-8-72 DATE: 1-7-72 DATE: 1/9/72
DECIMALS: .XXX = .005, .XX = .02, X = .1	ANGLES: ±0° 30'	digital EQUIPMENT CORPORATION MAYNARD MASSACHUSETTS TITLE: LINE SET 230V AC 4 AMP
REMOVE BURRS AND BREAK SHARP CORNERS SURFACE QUALITY ✓	NEXT HIGHER ASSY.	
MATERIAL: + + +	SCALE: + + +	SIZE CODE: C UA
FINISH: + + +	SHEET 1 OF 1	NUMBER: BC05J-0-0

This drawing and specifications herein, are the property of Digital Equipment Corporation and shall not be reproduced or copied or used in whole or in part as the basis for the manufacture or sale of items without written permission.

DIGITAL EQUIPMENT CORPORATION
MAYNARD, MASSACHUSETTS

ENGINEERING SPECIFICATION

DATE 3/9/73

TITLE DW8E ENGINEERING SPECIFICATION

REVISIONS

REV	DESCRIPTION	CHG NO	ORIG	DATE	APPD BY	DATE
A	CHANGE PER ECO	DW8E - 00003	REED	4/73	<i>Ed Reed</i>	5/73

ENG	ED REED	APPD	STEVE GROSS	SIZE	CODE	NUMBER	REV
				A	SP	DW8-E-12	A

ENGINEERING SPECIFICATION



CONTINUATION SHEET

TITLE DW8E ENGINEERING SPECIFICATION

1. General Description

1.1 The DW8E I/O Bus Converter accepts the I/O bus and Data Break Bus of both negative and positive PDP-8 family machines (LINC8, PDP8, PDP8/L, PDP8I and PDP12) and converts these signals to OMNIBUS format. The unit mounts on rotating slides in a standard nineteen-inch relay rack or DEC option cabinet.

1.2 The DW8E primarily provides an interface between a Family-of-8 Bus and an RK8F Disk System (see section 7) enabling the bi-directional transfer of: Programmed IOT's via the PDP8 accumulator; and Data Break information via the single cycle data break facility.

2. Physical Specification

2.1 The DW8E Bus Converter is provided with chassis slides for mounting in DEC standard 19-inch cabintry.

Dimensions: 10½ inches high
14½ inches deep
16 ¾ inches wide

Operating Temperature: 32°- 130°F (0°- 55°C) @ 0% to 90% humidity, non-condensing)

Power Requirements: DW8E-PA and NA
95 to 130 volts self-contained
47 to 63 Hz
4 Amps maximum
DW8E-PB and NB
185 to 250 volts self-contained
47 to 63Hz
2½ Amps maximum

Power Dissipation: 500WATTS

Power Supply: H740
+15V@1 Amp
+5V @ 17 Amps
-15V @ 5 Amps

SIZE	CODE	NUMBER	REV
A	SP	DW8-E-12	A

TITLE DW8E ENGINEERING SPECIFICATION

Module Types: M7101, M7102, M7103, M8320

Capacity: Five quad bus slots expandable to ten quad bus slots with DW8E-PX or DW8E-NX expander unit.

Altitude See operating specification of the peripherals installed on the DW8E.

Variations:
 DW8E-PA 115VAC, positive bus
 DW8E-PB 230VAC, positive bus
 DW8E-NA 115VAC, negative bus
 DW8E-NB 230VAC, negative bus
 DW8E-PX expander unit for either DW8E-PA or PB
 DW8E-NX expander unit for either DW8E-NA or NB

Type of cables:
 BC08B for DM04, PDP-8/L, and PDP12
 BC08D for DM01, PDP-8, Linc-8 and PDP-8/I

NOTE: Seven foot cables are supplied. A positive bus PDP-8I equipped with a DM04 will require BC08B cables.

3. Interface

3.1 The DW8E provides space for five quad modules. Programmed I/O (accumulator transfers) as well as data break transfers are handled by the basic unit. As many options and/or peripherals may be controlled via the DW8E as module slots permit. However, only one high-speed (data break) device can be used in the basic unit. The basic unit consists of: 1-M7101, 1-M8320 and 4-M7102's (or 4-M7103's).

3.2 The unit can be expanded as follows:
 If only one high-speed (data break) device is to be mounted inside the DW8E there are 5 quad bus slots available in the basic unit. (DW8E-NA/PA or NB/PD).

If two high-speed (data break) devices are to be mounted, or if additional slots are required, the expander section (DW8E-NX/PX) is required to be added to the unit. This puts, additionally, 1-M7101, 1-M8320 and 4-M7102's (or 4-M7103's) into the basic unit.

SIZE A	CODE SP	NUMBER DW8-E-12	REV A
-----------	------------	--------------------	----------

TITLE DW8E ENGINEERING SPECIFICATION

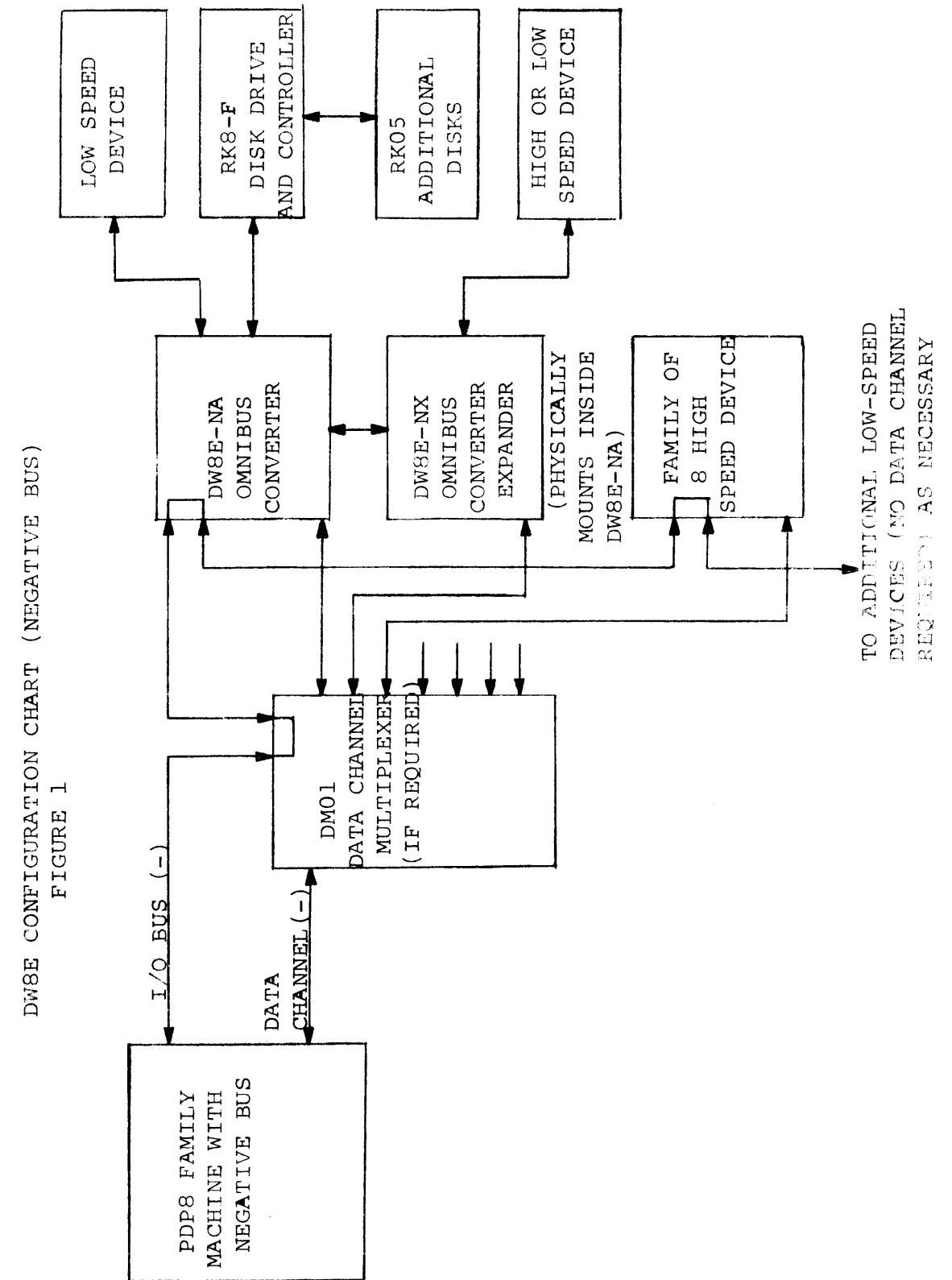

SIZE A	CODE SP	NUMBER DW8-E-12	REV A
-----------	------------	--------------------	----------



TITLE DW8E ENGINEERING SPECIFICATION

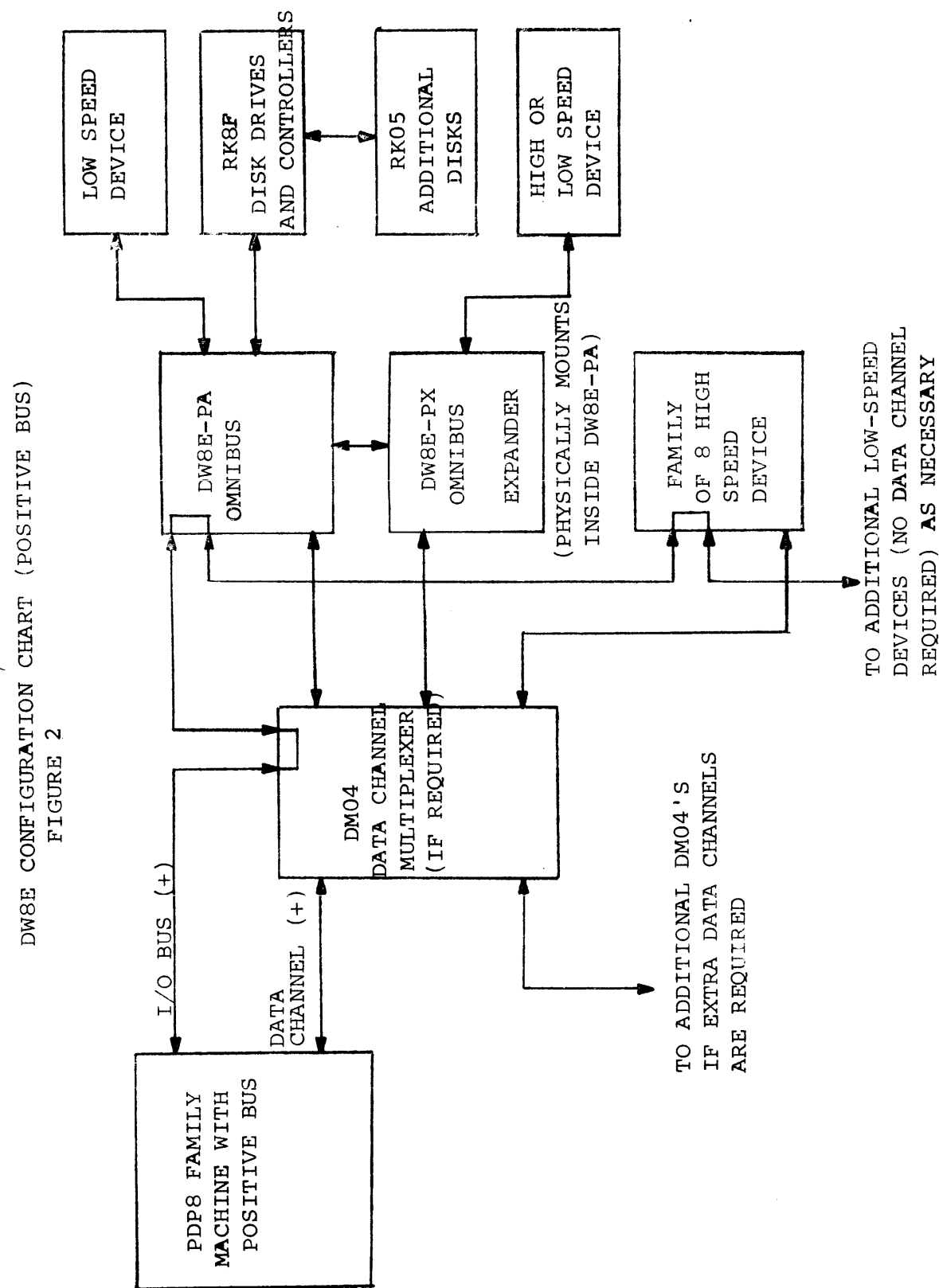

SIZE	CODE	NUMBER	REV
A	SP	DW8-E-12	A



TITLE DW8E ENGINEERING SPECIFICATION

3.3 Figures 1 + 2 show how the unit configures. Note that the DW8E does not perform the data channel multiplexing. Should two or more high-speed devices (data break) be used on a PDP system (either inside the DW8E or via the normal positive or negative I/O bus), a DM01 or DM04 data channel multiplexer is still necessary.

3.4 The DW8E must be the first device on the I/O bus and must have the highest priority slot when used with either a DM01 or DM04.

3.5 A DW08-A or DW08-B I/O bus converter must not be used to drive a DW8E.

3.6 PDP-8 Installation & LINC-8

3.6.1 PDP-8 ECO #8M-00007 must be installed in the PDP-8. This replaces timing signal B72A with B MEM START on the I/O Bus cable. (ECO #LINC8M-00008 IN THE LINC-8)

3.6.2 All system diagnostics should be run prior to, and after, installation of the ECO to assure no latency problems.

3.6.3. Margins should be run on the PDP-8 while running the RK8E Drive and Control Test, "MAINDEC-08-DHRKB-B-PB".

3.6.4 M7101 revision F, or modified version D or E boards, should be used in the DW8E, or later.

4. Programming

No specific IOT's are associated with the DW8E bus converter. The function of the converter is to translate the PDP-8 family external bus format into the OMNIBUS format.

4.1 The execution of a 6XX0 on the DW8E bus converter would be considered a NOP by the processor since no input or output would be executed.

4.2 I/O cycles will occur in 4.25 micro sec.

4.3 The skip bus may only be used to increment the PC by one location.

SIZE	CODE	NUMBER	REV
A	SP	DW8-E-12	A

TITLE
DW8E ENGINEERING SPECIFICATION

4.4 The time to complete non I/O cycles will be: 1.5 micro sec. for 8, 8I. 1.6 micro sec. for 8L.

4.5 Only single cycle data break is allowed. A data break cycle will precede a Fetch cycle only, and will be followed by at least one machine cycle.

4.6 The peripheral will halt with time state 3 asserted.

SIZE	CODE	NUMBER	REV
A	SP	DW8-E-12	A

TITLE
DW8E ENGINEERING SPECIFICATION

5. Omnibus Signals
The following signals are available.

Signal Function

Data Bus	Data 0-11
Memory Add	MA 0-11, EMA0-2
Memory Data	MD 0-11
Time States	TS1, TS2, TS3, TS4
Time Pulses	TP1, TP2, TP3, TP4, Int Strobe
I/O Cables	C0, C1, SKIP, Int RQST, I/O PAUSE
Memory	MD DIR
DATA BREAK	BRK IN PROG
MISC	Run, Power OK, Initialize, +5, +15, -15, GND

5.1 Timing Diagrams

- 5.1.1 OPR Cycle
see fig. 3
- 5.1.2 I/O Cycle
see figs. 4, 5, 6
- 5.1.3 Data Break Cycle
see fig. 7

6. Limitations

The following signals are NOT available.

Signal Function

Memory Control	ALL SIGNALS
Processor States	ALL SIGNALS
Programmer console	ALL SIGNALS
Programmed I/O	C2, Buss strobe NOT LAST XFER
Data Break	INT IN PROG CPMA Disable Over Flow Break Data Control MS IR Disable MA MS Load Control

SIZE	CODE	NUMBER	REV
A	SP	DW8-E-12	A



TITLE DW8E ENGINEERING SPECIFICATION

7. Equipment Requirements

7.1 The following peripherals may be used with the DW8E

- 7.1.1 RK8F
- 7.1.2 DB8E
- 7.1.3 KL8E
- 7.1.4 KL8F

7.2 RK8F Requirements

7.2.1 All Family of 8 machines must have a data break facility.

7.2.2 The M7105 Major Registers module of the RK8E must be modified to M7105-YB, and M7104 to M7104-YA.

7.3 DB8E Requirements

7.3.1 NONE

7.4 KL8E Requirements

7.4.1 IOT code 0 must not be used.

7.5 KL8F Requirements

7.5.1 IOT code 0 must not be used.

SIZE	CODE	NUMBER	REV
A	SP	DW8-E-12	A

SHEET 9 OF 19



TITLE DW8E ENGINEERING SPECIFICATION

8. DW8-E Theory of Operation

The configuration of the DW8-E I/O bus converter is to use PDP-8 I/O bus timing to generate Time States 1, 2, 3, & 4 (TS1, TS2, TS3, TS4); Time Pulses TP1, TP2, TP3, TP4; and signals necessary to transfer information in or out of approved 8/E omnibus options via AC transfers (IOT's) or Data Break Transfers (single-cycle).

Figures 3, 4, 5, 6 & 7 illustrate the OPR, IOT, & BREAK cycle timing which is generated by the control card M7101.

OPR CYCLE - Figure 3 shows the timing sequence of a basic Operate or memory reference instruction. Referring to a control module print (C-CS-M7101-0-1, D-BS-DW8-E-3 or D-BS-DW8-E-5) the control is initially set to Time State 1 by INITIALIZE L.

Timing is sequenced by the level changes of BTS 1 and BTS 3 from the PDP8 computer. These level changes generate the TP pulses, which in turn generate SHIFT TS H. This shifts the control to the next time state. CLR TP L then clears the TP pulse flops after the shift.

When the control is in Time State 1, BTS 1 going away sets TP1. SHIFT TS H shifts the control to Time State 2 and CLR TP L clears TP1. In Time State 2, BTS 3 going high causes the shift to Time State 3. If the machine is halted the control will stop in Time State 3. TP3, Time State 4 and TP4 occur during BTS 1 Time of the following cycle.

In Time State 3, BTS 3 going away sets TIME PAUSE. BTS 1 of the next cycle generates CLR TIME PSE L which clears TIME PAUSE and issues TP3, shifting to Time State 4. 150 NS after TIME PAUSE is cleared, RECYCLE issues TP4 which shifts it again to Time State 1.

Note in the delay circuitry for SHIFT TS L and CLR TP L that these signals are fed back to their own inputs, to limit their pulse widths to 50NS. CLR TP L also disables the input to the delay for SHIFT TS H. This prevents recirculating pulses before the TP input goes away.

IOT CYCLE - Figures 4 & 5 show the elongated IOT cycle.

SIZE	CODE	NUMBER	REV
A	SP	DW8-E-12	A

SHEET 10 OF 19

TITLE DW8E ENGINEERING SPECIFICATION

FIGURE 3.

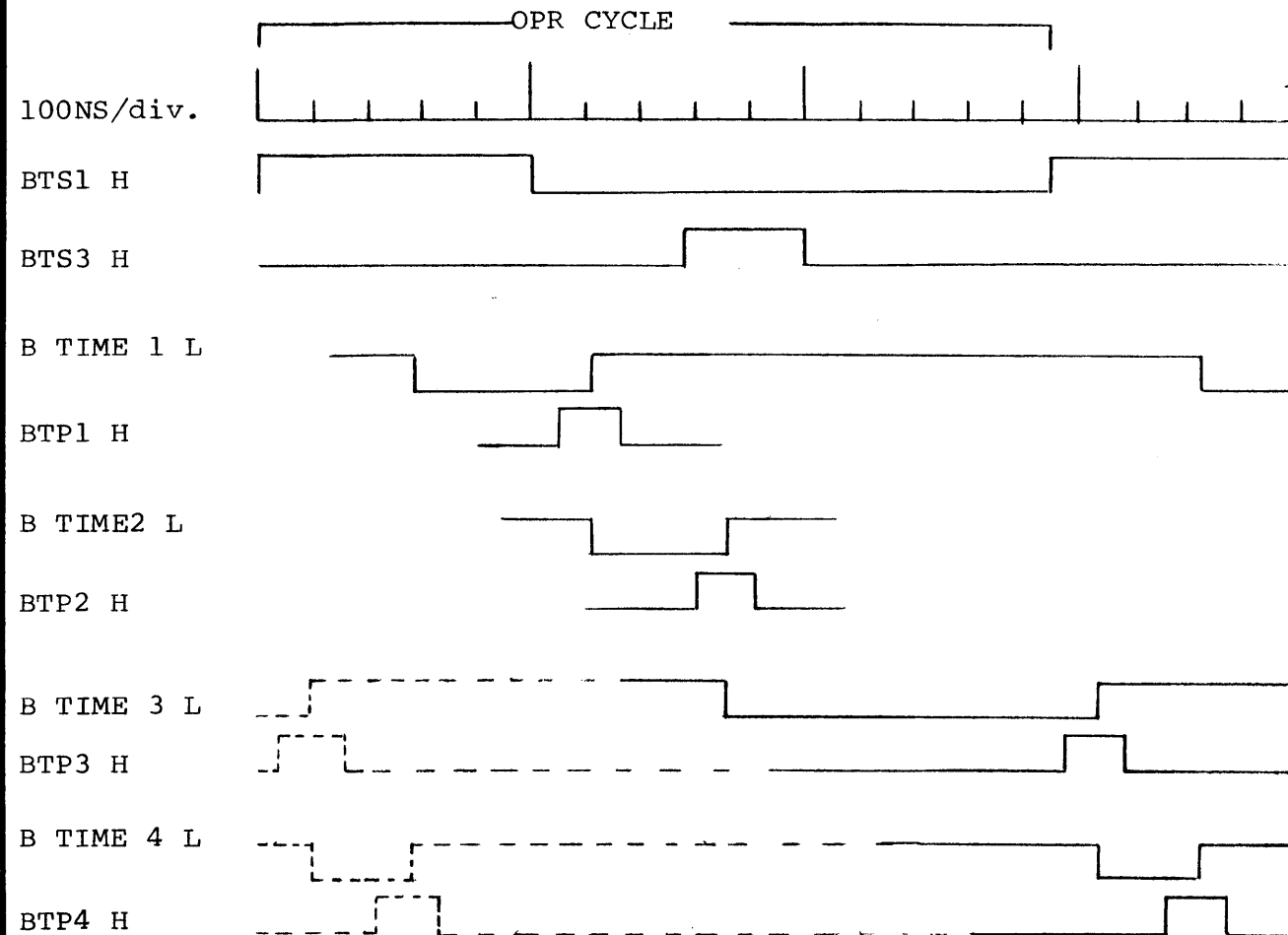

NOTE: TP3, TIME STATE 4 and TP4 are issued during BTS1 of the following cycle.

The Times shown here for BTS1 and BTS3 are typical for a PDP-8I. For a PDP-8L they are 650 NS and 250 NS. For a PDP-8 they are both 400 NS.

SIZE	CODE	NUMBER	REV
A	SP	DW8-E-12	A

TITLE DW8E ENGINEERING SPECIFICATION

The function is to issue I/O PAUSE L and TP3 H to the option and also to receive and interpret CØL and ClL from the option. The timing of these events to each other remain the same although they occur on the first of the IOP pulses which are issued.

CØL causes the accumulator to be cleared by CLR AC H which enable the AC CLEAR BUS for 700 NS. ClL causes the AC to be loaded with the contents of a buffer register in the option via the AC INPUT BUS which is enabled for 400 NS by B Cl H.

The CØ and Cl combinations are:

- $\overline{CØ} . \overline{Cl}$ = Load buffer register with contents of AC, don't clear AC.
- $\overline{CØ} . Cl$ = Don't clear AC, "OR" contents of buffer register to AC.
- $CØ . Cl$ = Clear AC, then load contents of buffer register to AC.
- $CØ . \overline{Cl}^*$ = Load buffer register with contents of AC, then clear AC.

When any combination of IOP1, IOP2, IOP4 is issued, I/O END CLK L follows the IOP levels inversely. For any combination of CØ and Cl (except CØ . Cl*) I/O END CLK H will follow I/O END CLK L.

I/O PSE (1) H is set by the leading edge of the first IOP pulse and I/O END CLK H goes low. When the IOP pulse goes away I/O END CLK H goes high setting I/O END. This issues CLR TIME PSE L which clears TIME PAUSE, issues TP3, and shifts to Time State 4. CLR TP L then clears TP 3, I/O END, and I/O PAUSE.

The following IOP pulses do not set I/O PAUSE again because the control is out of Time State 3. 150 NS after TIME PAUSE is cleared, recycle issues TP4 and shifts into Time State 1 for the rest of the I/O cycle.

* $CØ . \overline{Cl}$ is the case where the contents of the AC must be loaded to the buffer register before the AC is cleared. The gate of the delay which was strobed by I/O END CLK L is enabled so that I/O END CLK H is only 300 NS long. I/O PAUSE is shortened and TP3 and the other events occur as before except that they are now earlier in the cycle.

PDP-8 IOT CYCLE - Figure 6.

SIZE	CODE	NUMBER	REV
A	SP	DW8-E-12	A

ENGINEERING SPECIFICATION

CONTINUATION SHEET

TITLE DW8E ENGINEERING SPECIFICATION

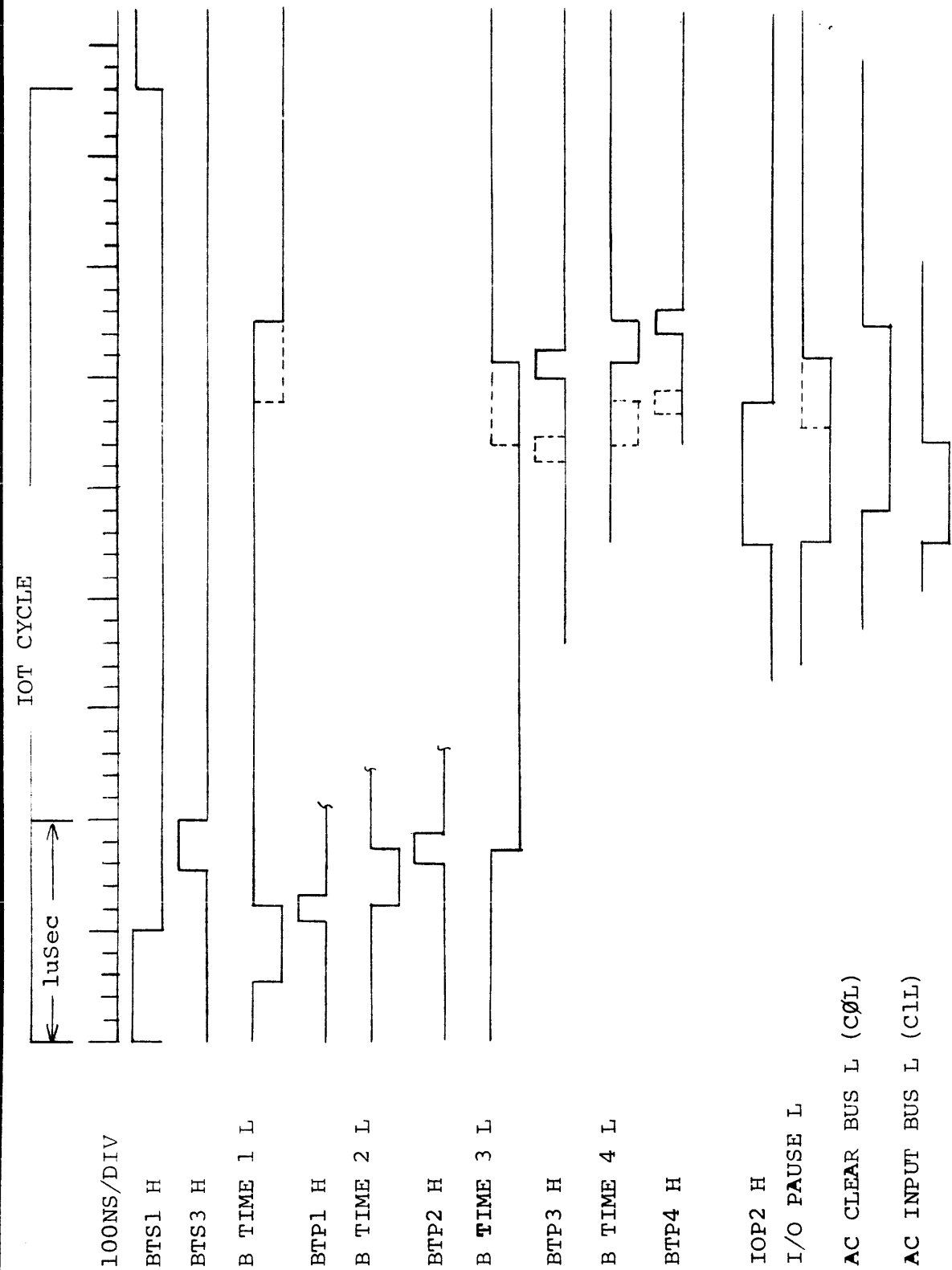

FIGURE 4

This shows a typical IOP2 load or read AC instruction. The solid lines indicate the times for CØ.CI, CØ.Cl and CØ.Cl. The dotted lines indicate the times for CØ.Cl (load AC to buffer, clear AC).

SIZE A	CODE SP	NUMBER DW8-E-12	REV A
------------------	------------	--------------------	-----------------

ENGINEERING SPECIFICATION

CONTINUATION SHEET

TITLE DW8E ENGINEERING SPECIFICATION

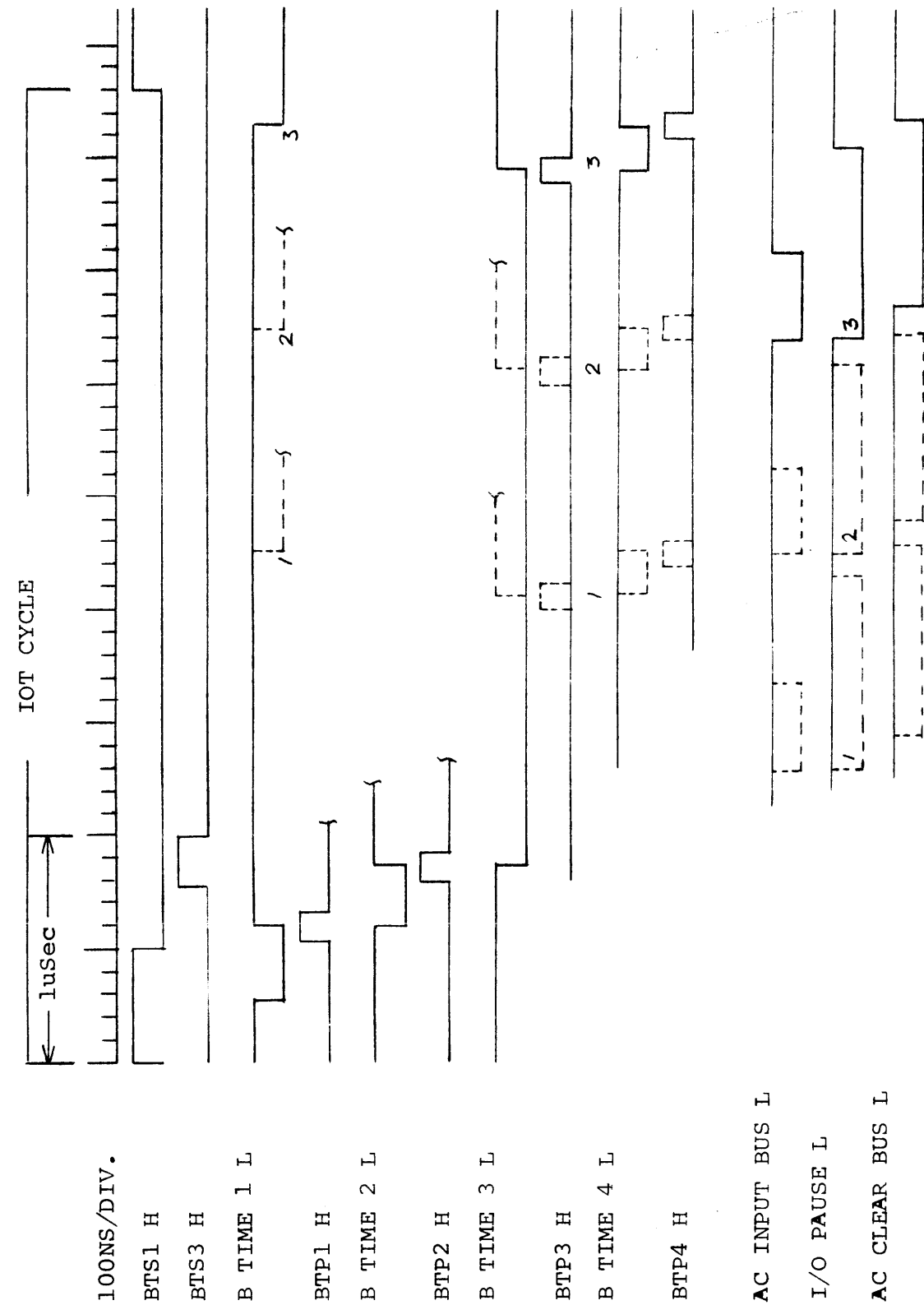

FIGURE 5

The timing shown here is for CØ.CI, CØ.Cl, CØ.Cl.

Notes: 1=IOT's using IOP 1, 3, 5, 7
2=IOT's using IOP 2, 6
3=IOT's using IOP 4

SIZE A	CODE SP	NUMBER DW8-E-12	REV A
------------------	------------	--------------------	-----------------

TITLE DW8E ENGINEERING SPECIFICATION

The DW8E depends on BTS1 and BTS3 for complete time synchronizing with the computer. But the signals which the PDP-8 sends are not entirely usable.

BT2A would normally replace BTS1. It occurs during the IOT cycle but is not present at Memory Start time of the following cycle to continue the timing.

ECO #8M-00007 must be installed in the PDP-8 to send B MEM START to the DW8E in place of BT2A on the I/O bus cable. (ECO # LINC8M-00008 IN THE LINC-8)

BT1B replaces BTS3 except that the PDP-8 issues a second T1B pulse during the IOT cycle.

This second BT1B pulse is eliminated internal to the DW8E by a flip flop which is clocked by the first BT1B pulse going away. The flip flop drives an open-collector inverter which is fed back to hold the BT1B input to ground. This grounds the collector of the M7103 transistor in the BT1B negative to positive bus converter circuit so that the extra BT1B does not get through. MEM START at the beginning of the next cycle clears it.

BREAK CYCLE - Figure 7.

BRK IN PROG L from the option is used to send BRK RQST L directly to the computer. (See D-BS-DW8-E-4 or D-BS-DW8-E-6).

TS4 and TP4 from the previous cycle are not entered. When BK CYCLE H is true, SHIFT TS H forces the Time State flops directly to Time State 1.

Time State 4 of the BREAK cycle is entered during the cycle by BTS3 going away which is ANDed with BRK H. The current address register in the option is incremented during TS4.

BREAK H and BREAK L are issued to the option by the BRK FLOP which is set 100 NS after shifting into Time State 1. They are ANDed in the option with ADD ACC to gate off a following request for a Data Break. Back to back Breaks can not be allowed because the PDP-8 must synchronize on a Break Request earlier in its cycle than an 8/E.

SIZE A	CODE SP	NUMBER DW8-E-12	REV A
-----------	------------	--------------------	----------

TITLE DW8E ENGINEERING SPECIFICATION

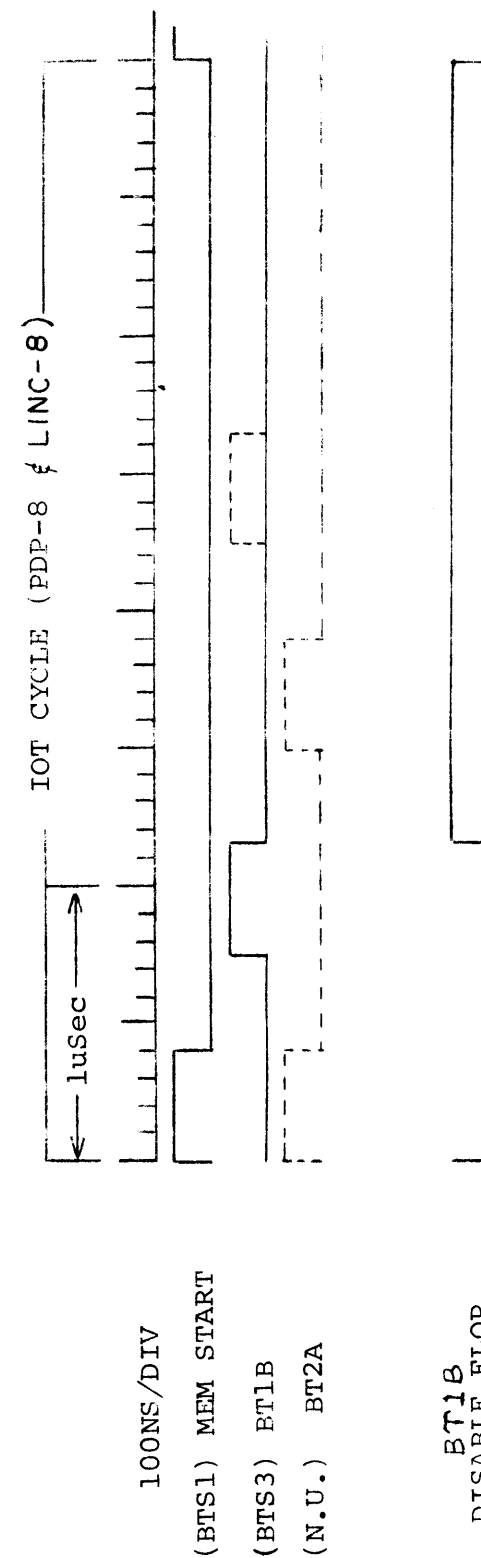
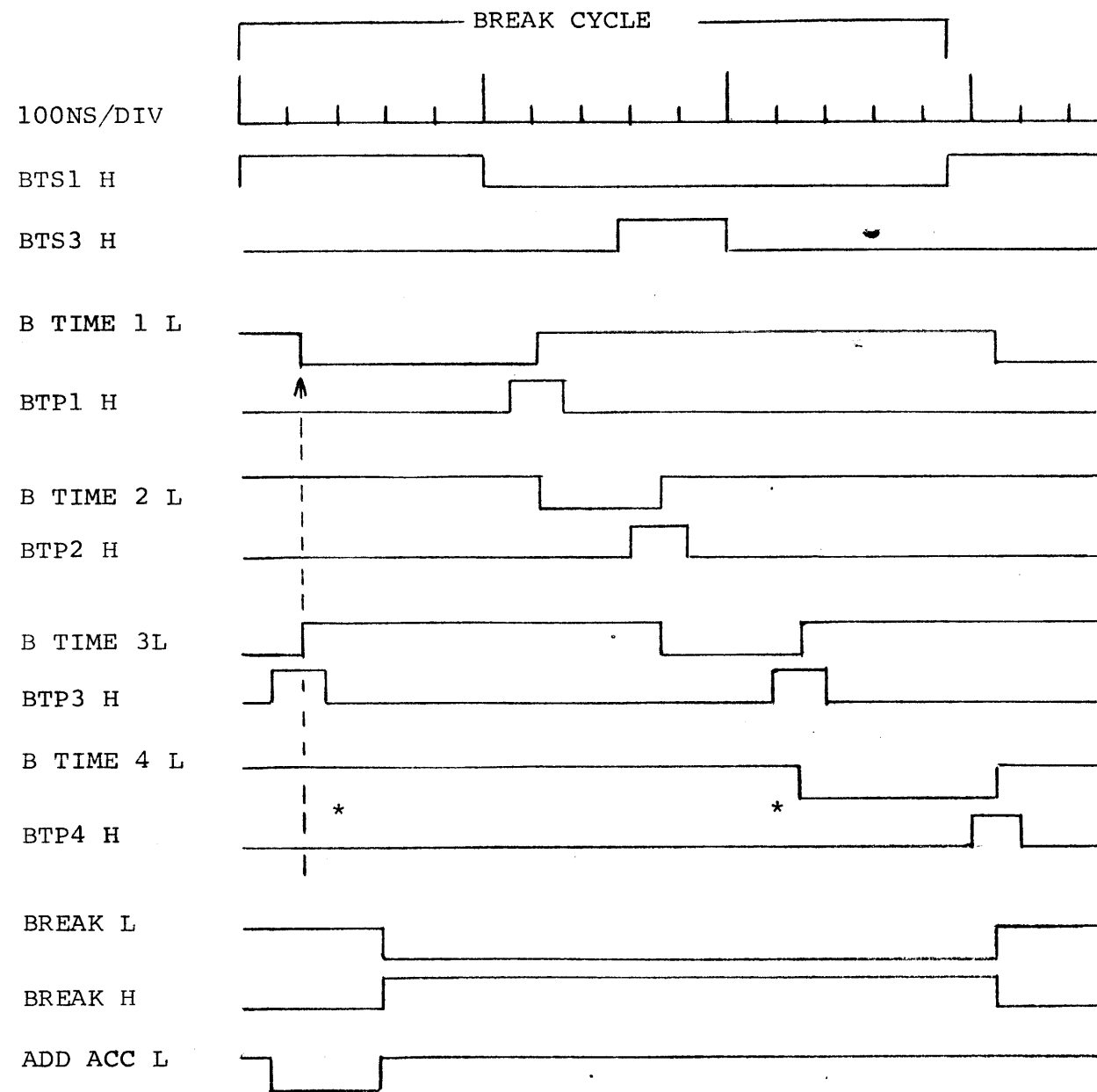

FIGURE 6.

SIZE A	CODE SP	NUMBER DW8-E-12	REV A
-----------	------------	--------------------	----------

TITLE DW8E ENGINEERING SPECIFICATION

FIGURE 7



*NOTE: 1) Time State 4 and TP4 from the previous cycle are not allowed when entering the Break Cycle. The control goes directly to Time State 1.
 2) Time State 4 for the Break Cycle is entered during the Break Cycle.

SIZE A	CODE SP	NUMBER DW8-E-12	REV A
-----------	------------	--------------------	----------

TITLE DW8E ENGINEERING SPECIFICATION

There are two further constraints to the option. The Break Address must be on the Bus before the Break Cycle. Also, the Data to be transferred into the computer must be on the Bus before Time State 2. Data to be read from the computer is loaded by the peripheral with the leading edge of TP3.

Information Multiplexing - (DWG. D-BS-DW8-E-4 or D-BS-DW8-E-6). Four M7102's are used to interface to a PDP-8 positive I/O bus. Operation of the M7103's are identical except that the M7103 has negative to positive receivers, and positive to negative drivers, to interface to a PDP-8 negative I/O bus. The M7102 and M7103 are pin-compatible.

Each M7102 or M7103 handles 3 information lines and 4 address lines and has sufficient circuitry to utilize the control and timing signals. The circuitry from input pins AP2 and AR2 allows for the fact that on the positive I/O Bus these signals are positive pulses but are negative pulses on the negative I/O bus. These signals are: BTS1, BTS3, BIOP1, BIOP2, BIOP4 and B INITIALIZE.

Figure 8 is a representative of the interfacing of the signals between the PDP-8 I/O bus and the derived OMNIBUS I/O signals.

FIGURE 8.

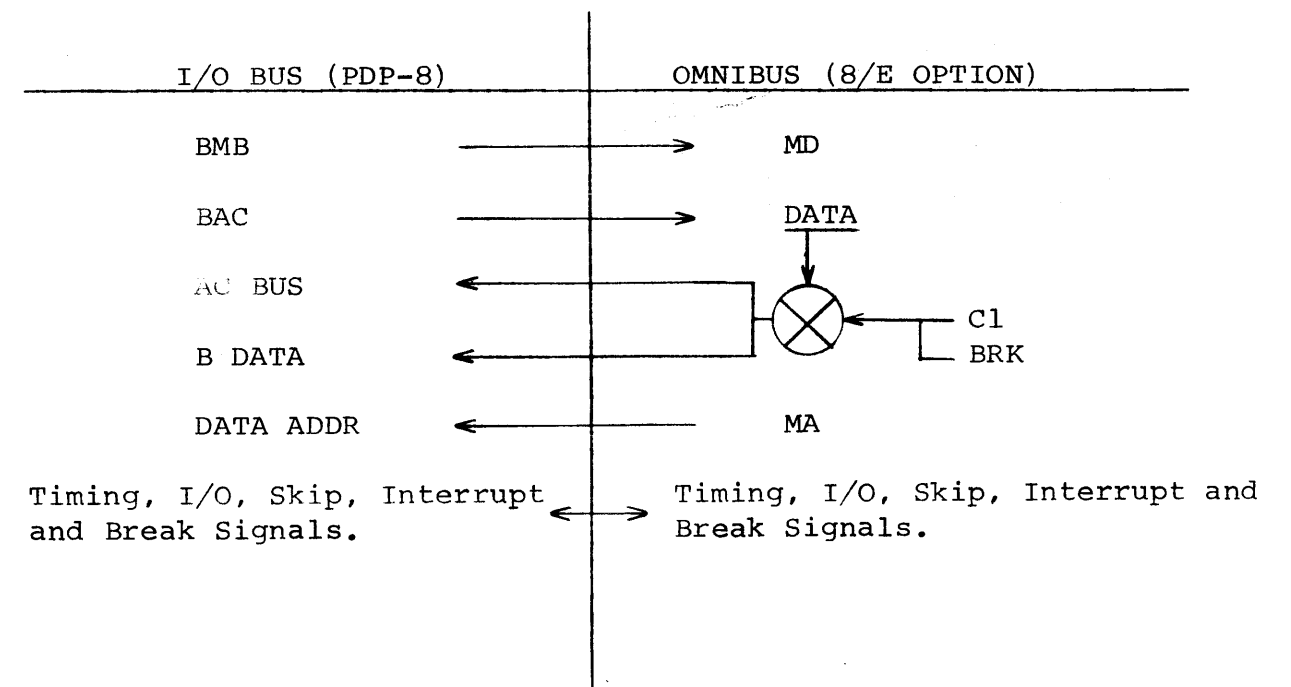

Timing, I/O, Skip, Interrupt and Break Signals.

Timing, I/O, Skip, Interrupt and Break Signals.

SIZE A	CODE SP	NUMBER DW8-E-12	REV A
-----------	------------	--------------------	----------

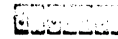

TITLE DW8E ENGINEERING SPECIFICATION

The BMB bits are used to drive the MD (Memory Data) lines directly without any gating. The BAC bits are normally gated onto the bi-directional DATA lines. If an IOT instruction is given to read an option buffer to the AC, the C1 line comes true. This turns off the BAC and gates the contents of the DATA lines onto the AC input Bus lines so that they can be strobed into the AC by the computer.

BRK comes true at the beginning of a Break Cycle. This also gates off the BAC but gates the DATA lines onto the B DATA lines which are strobed into the Memory Buffer of the computer.

The Memory Address (MA) and Extended Memory Address (EMA) bits are used to drive the DATA Address and Extended Data Address lines directly to the computer. Other signals which are used to drive lines directly to the computer are: SKIP, INT RQST, BRK IN PROG (BRK RQST), ADD ACC, and MD DIR (DATA IN). The cycle selection input is grounded to request only Single-cycle Data Breaks (1 cycle).

BREAK H and BREAK L inputs are driven by the (1) H and (1) L sides of the BRK flop from the M7101 control card.

The AC CLEAR BUS is driven by the 700 NS delay CLR AC from the M7101 and I/O PAUSE to the OMNIBUS is driven from the M7101 by the flop I/O PSE.

SIZE A	CODE SP	NUMBER DW8-E-12	REV A
-----------	------------	--------------------	----------

