

digital

CONTINUATION SHEET

TITLE

Disk Cartridge Memory - RK08/RK01

flange on the lower side of the cartridge. These nine slots are sensed by a photo diode and indicate the start of one of eight sectors. A ninth slot gives the information necessary to determine sector 0.

The cartridge is a single aluminum platter coated on both sides with magnetic oxide. It is permanently mounted inside a protective case that automatically opens when inserted in the disk drive. A magnetic material in the drive spindle assembly engages the bottom of the cartridge to couple the platter to the drive motor.

SIZE	CODE	NUMBER	REV
A	SP	RK01-0-6	

digital

CONTINUATION SHEET

TITLE

Disk Cartridge Memory - RK08/RK01

Specifications

Storage Capacity	Each RK01-K Cartridge stores 831,488 12 bit words.
Expansion	Four RK01 drives may be controlled by one RK08 control for 3,325,952 words total.
Transfer Path	Single cycle Data Break
Transfer Rate	16.7 us per word
Minimum Access Time	2.0 ms step plus 37 ms settle time.
(adjacent tracks)	
Average Access	133 ms including settle time.
Maximum Access	400 ms including settle time.
Latency Maximum	(1 revolution) 40 ms
Latency Average	(1/2 revolution) 20 ms
Program Interrupt	Transfer Done Flag Error Flag
Write Lock	Individual sectors or an entire drive can be write protected.
Data Tracks	200 Plus 3 spare
Words per Track	4096 (2048 on each of two surfaces)
Sectors	16

SIZE	CODE	NUMBER	REV
A	SP	RK01-0-6	

TITLE

Words per Sector 256
 Minimum Block Size 256
 Maximum Block Size 4096
 Recording Method Double Frequency-Time Plus Data
 Density 704 bits/inch (outer track)
 1026 bits/inch (inner track)
 Speed 1500 rpm
 Environmental Requirements:
 (a) Operating temperature (environment) +65°F to +90°F. 20°F per hour cycle rate.
 (b) Storage temperature (environment) +20°F to +165°F for a period of 6 months when packed for storage and shipment.
 (c) Operating humidity (environment) 20% to 80%, excluding all conditions which would cause moisture to condense in or on the equipment.
 (d) Storage and shipping humidity range; minimum 5%, maximum 95% up to 100°F. no condensation resulting in moisture on or in the equipment will be tolerable.

SIZE	CODE	NUMBER	REV
A	SP	RK01-0-6	

TITLE

Heat Dissipation RK08 - 150 watts total
 RK01 - 700 watts, 1000 watt surge per drive.
 AC Power Requirements 115 ± 10 VAC, 60 Hertz ± ½ Hertz.
 (a) MTBF equal to or greater than 1000 hours of power on time (a failure is any function requiring unscheduled maintenance.)
 (b) Scheduled preventative maintenance - about 0.5 hrs. per 200 hours on time.
 (c) Recoverable Error Rate - one error per 10¹⁰ bits transferred (a recoverable error is defined as an error which disappears within 5 attempts to complete the operation.)
 (d) Unrecoverable Error Rate - less than one unrecoverable per 10¹² bits transferred (an unrecoverable error is defined as an error which persists after 5 attempts to complete the operation.)

SIZE	CODE	NUMBER	REV
A	SP	RK01-0-6	

TITLE

Cabinets

Subsequent restoration of performance may require prescribed cleaning of heads and/or disk.)

(e) Service Life - The device has been designed for a life of 5 years or 24,000 hours, whichever occurs first before factory overhaul or replacement is required.

One cabinet will accomodate the RK08 and one RK01. A second cabinet will house two RK01 units. A third cabinet will house a fourth RK01.

SIZE A	CODE SP	NUMBER RK01-0-6	REV
------------------	------------	--------------------	-----

TITLE

Programming Sequence

Transfers are through single cycle Data Break. A normal programming sequence is as follows:

1. The word count and current address are placed in the word count and current address registers.
2. The command register is then loaded from the Accumulator. Normally, only the unit number, extended memory address, or seek mode would be changed. Status change in interrupt or rewriting of protect and status words would normally not take place.
3. The track, surface, and sector units are loaded from the accumulator and the instruction (read, write, check parity) is executed.
4. As desired, interrupts will occur when the instruction is complete or when there is an error. Errors will halt transfers.

SIZE A	CODE SP	NUMBER RK01-0-6	REV
------------------	------------	--------------------	-----

TITLE

Format Description

General

Each new cartridge is considered to be barren of useful data. Track and sector information must be written on the cartridge before it can be used by normal programs. The following describes the format of this information.

A cartridge surface is divided into 203 tracks. Each track is further divided into 16 parts called sectors; sectors 0 to 7 are on side zero of the cartridge and sectors 10 to 17 are on side 1 of the cartridge. Each individual sector, which contains enough area to store track and sector information plus 256 data words, can be addressed by the control. If a normal transfer is made starting from sector 0, 4096 data words can be transferred, 2048 words from side zero, and 2048 words from side one.

Transfer of data blocks that total more than the number of sectors from the starting sector to sector 17 is an error as indicated by the track capacity error flag.

Within a sector, the area is subdivided into a 2 word header region and a 256 word data region. The 2 word header contains track and sector information plus other data explained

SIZE A	CODE SP	NUMBER RK01-0-6	REV
-----------	------------	--------------------	-----

TITLE

later. The 256 word data region contains the data words, a 12 bit longitudinal parity and a 12 bit guard word which is nothing more than a convenient area to turn off write amplifiers. Other information written for synchronization etc. is described in the detailed description of the format.

Sector Detail

Each sector is written with an area of data zeroes (a preamble region), a data one for a synch bit, two 12 bit plus parity header words, another area of data zeroes (preamble before data) another data one for a synch bit, 256 12 bit data words, one 12 bit longitudinal parity, and a 12 bit postamble word. During a read, the preamble region allows circuits to synchronize on the time pulses without being disturbed by data ones. The first data one read after the preamble region signifies that the region immediately following contains information. Similarly, the preamble region following the header words and prior to the first data bit is used for synchronization on timing pulses. The first data one bit after this region of data zeroes signifies that data immediately follows.

SIZE A	CODE SP	NUMBER RK01-0-6	REV
-----------	------------	--------------------	-----

TITLE

Since the sector is split into the two areas of header and data, normal read or write data instructions can be carried out after reading and checking the two header words. The region between the header words and data is used to switch circuits from read to write when performing a normal write. Therefore during a normal write the two header words are read, checked by the control, the preamble region following is used to switch to write, and the 256 words of data (plus longitudinal parity and postamble word) are written. Note that the two header words are not read into the computer during a normal read or write.

Normal read or normal write instructions can be executed when bit 5 of the command register is zero. When this bit is a one and the sector protect switch is off, both the header words and the data region are available to the program as a 258 word data block. This enables a program to "format" the disk by writing the header words and reading them to ensure they were written correctly.

First Header Word - Usage During Normal Read or Write

The first header word is the track surface sector address, identical to the format of the address held in the computer

SIZE	CODE	NUMBER	REV
A	SP	RK01-0-6	

TITLE

accumulator when executing a read or write instruction. After being read, this first header word is compared to the track address registers of the control to ensure that the correct track is being accessed. The sector portion of this header word is compared with the sector address requested by program. If they are not equal, the control resets itself until the next sector. If they are equal, the transfer of 256 data words is completed. If another 256 data words are to be transferred (word count not equal to zero), one is added to the sector address requested by program and this new sector is found in the same manner as before.

Note that sectors are identified by data written by a program. Therefore, sector numbers do not have to be sequential but can be interleaved for maximum throughput.

Second Header Word - Usage During Normal Read or Write

The second header word when read during a normal read or write is checked as follows: a) If bit zero is equal to one AND the sector protect switch is on AND a normal write is requested, terminate transfer and raise write lock error flag. If these conditions are not true, continue transfer.

SIZE	CODE	NUMBER	REV
A	SP	RK01-0-6	

TITLE

b) If any of bits one to five are a one, during a normal read or write, terminate transfer and set the sector no good flag. These bits are set to a one to indicate that the sector has a permanent flaw and cannot be reliably written or read.

c) Bits 6 to 11 are unused.

Special Note: The previously described functions of checking for correct track address, finding of sector numbers, checking of parity, write lock, sector no good bits, etc. are all performed automatically and require no intervention by the program when they are carried out.

SIZE	CODE	NUMBER	REV
A	SP	RK01-0-6	

SHEET 13 OF 27

TITLE

Sector Sequence

The sequence of sectors accessed during read or write is determined by the formatting program. The simplest format should be used where large blocks of data are being transferred. 4096 words are transferred in 80 ms.

<u>Surface 0</u> Sector #	<u>Surface 1</u> Sector #
0	8
1	9
2	10
3	11
4	12
5	13
6	14
7	15

To allow milliseconds of calculations on data between transfers, without requiring one revolution before the next sector appears, the following format should be used:

<u>Surface 0</u> Sector #	<u>Surface 1</u> Sector #
0	8
3	11
6	14
1	9
4	12
7	15
2	10
5	13

This allows 10 ms between sectors. 4096 words are transferred in 240 ms. Other formats are possible.

SIZE	CODE	NUMBER	REV
A	SP	RK01-0-6	

SHEET 14 OF 27

TITLE

Control Description

The control contains an up/down counter called the track address counter which keeps count of the track number. This counter holds the current location of the heads and is the active track register. Another register, the track address register, is loaded under program control from the accumulator. The control will step the up/down counter and the head positioner until the counter and track address register are equal.

After the control finds the correct track, the header of the first sector that appears under the read/write head is read. The track address portion of the header word is compared with the track address register. If they are not equal, the address error flag is raised and operation will be terminated.

Sector selection is performed by loading a register from the accumulator with sector number plus surface. The sector address portion of the header word is compared with the sector address register. If they are equal, a read or write operation continues. If they are not equal, consecutive sectors are read until the correct one is found. If after 56 revolutions the correct sector is not found, the time out error flag is set.

SIZE	CODE	NUMBER	REV
A	SP	RK01-0-6	

TITLE

Multidisk Operations

One extra feature has been added to aid the programmer in multidisk operations.

When a drive is first selected during a normal read or write (bit 5 of the command register must be zero) the control will read the track over which the drive heads are positioned. The information which is utilized is the first header word of any sector. This header word contains the track number over which the drive heads are positioned. This track number updates the track address counter and then the instructions, if any issued from the computer, are executed. This operation is necessary, only in multidisk operation and is performed so the program is not forced to calculate a drive's current track location and update the track address counter when switching from drive to drive.

SIZE	CODE	NUMBER	REV
A	SP	RK01-0-6	

TITLE

Programming Instructions

Mnemonics Octal

DLDC 6732 Load Command Register
 Load the Command Register from the AC, clear AC

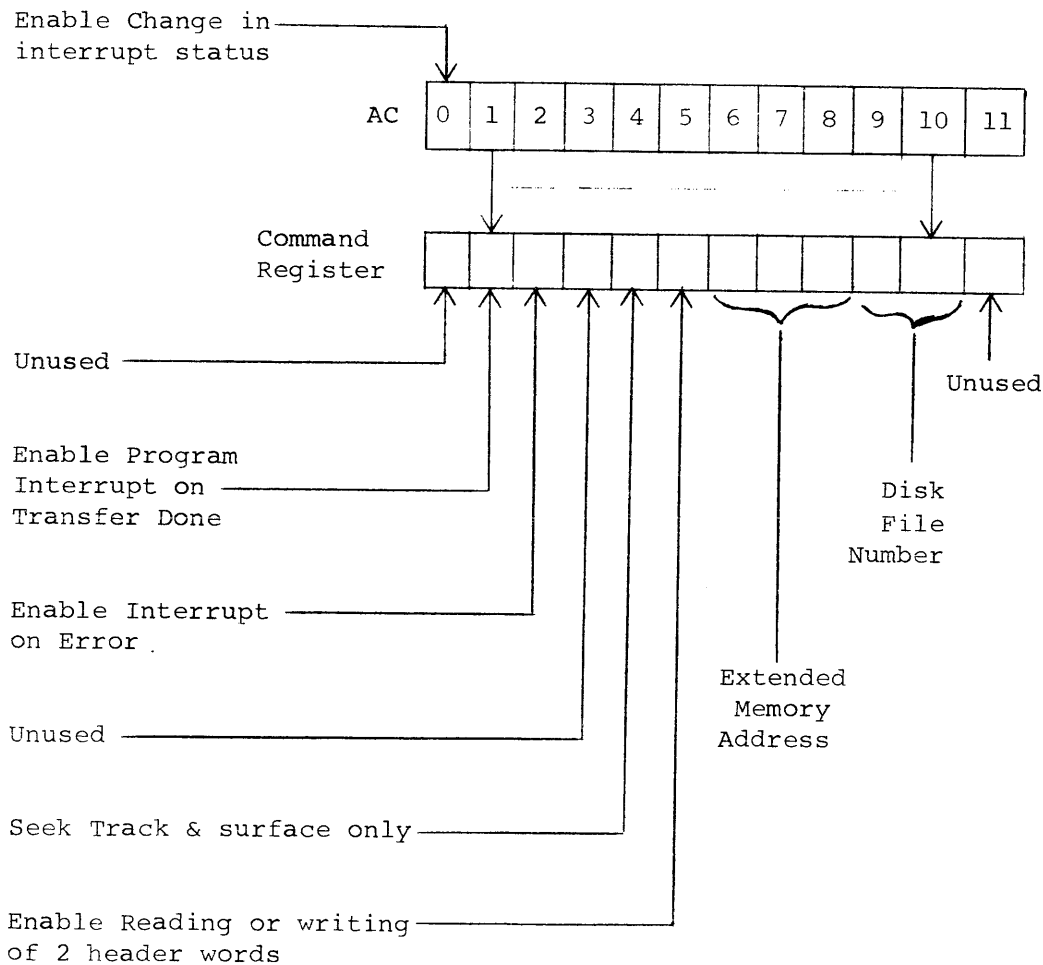

Logical "1" = Function true

SIZE A	CODE SP	NUMBER RK01-0-6	REV
-----------	------------	--------------------	-----

TITLE

Mnemonics Octal

*DLDR 6733 Load Disk address and Read
 Loads track, surface, and sector address from AC, then clears AC, Starts to Read data from disk if Command Register bit 4=0

*DLDW 6735 Load Disk address and Write
 Loads track, surface, and sector address from AC, then clear AC, Starts to write on disk if Command Register bit 4=0.

*DCHP 6737 Load disk address and Check Parity
 Loads track, surface, and sector address from AC, then clears AC. Reads data and checks Parity if Command Register bit 4=0.

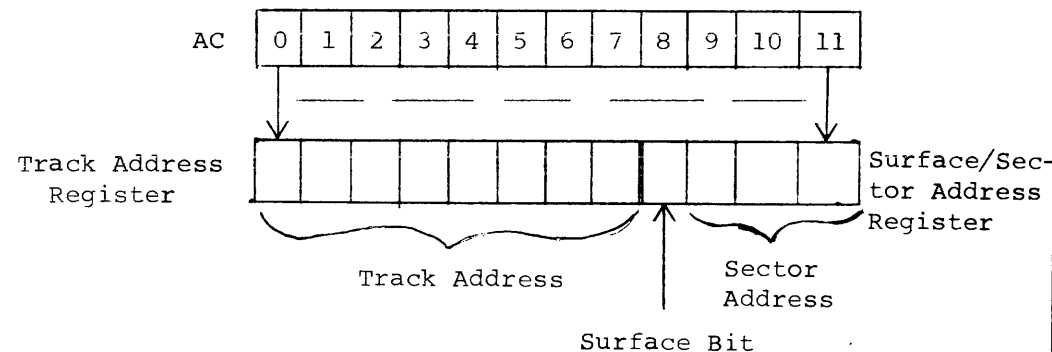

DRDA 6734 Read Disk Address
 Clears AC and then reads Track Address Counter, and surface/sector counter into AC.

DRDC 6736 Read Disk Command register
 Clears AC then reads Command Register into the AC.

*If command register bit 4=1, instruction will be executed only to seek track and surface. These 3 instructions start all disk operations.

SIZE A	CODE SP	NUMBER RK01-0-6	REV
-----------	------------	--------------------	-----

TITLE

Mnemonics Octal

DRDS 6741 Read Disk Status Register

Clears the AC and then reads the Status Register into the AC.

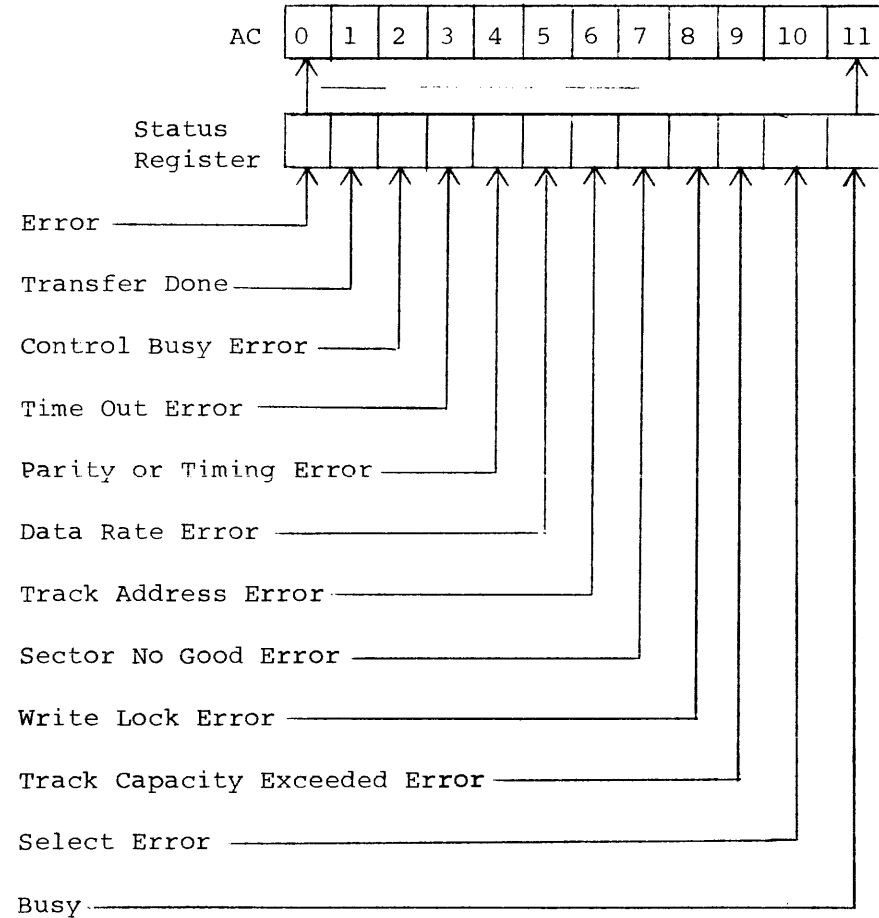

Logical 1 = function true

DCLS 6742 Clear Status Register

SIZE	CODE	NUMBER	REV
A	SP	RK01-0-6	

TITLE

Mnemonic Octal

DMNT 6743 Load Maintenance Register

Loads Maintenance register from AC, and carries out the operation specified. Bits will remain set until DMNT is issued with AC bits = 0.

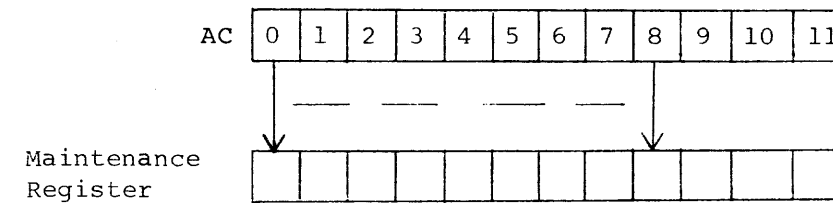

Logical 1 = function true

AC Bit

- 0 Transfer contents of Track address Register to Track counter Register
- 1 Transfer Data Register to Serial Register
- 2 Transfer Serial Register to Data Register
- 3 Clear AC and Read Data Register into AC
- 4 Shift a "1" into the Serial Register
- 5 Shift a "0" into the Serial Register
- 6 Unformatted Disk
- 7 Sector Pulse
- 8 Index Pulse
- 9-11 Not used

DLDA 6731 Load Disk Address (maintenance only)

SIZE	CODE	NUMBER	REV
A	SP	RK01-0-6	

TITLE		
<u>Mnemonics</u>	<u>Octal</u>	
DSKD	6745	Skip on transfer Done flag = 1
DSKE	6747	Skip on Error Flag = 1
DCLA	6751	Clear All
		Clears selected Disk to Track 000. Then clears all control registers and flags except Disk selection. Transfer done set when Disk positioned Track 000.
DRWC	6752	Read Word Count Register
		Clears AC; then reads the contents of the WC register into the AC.
DLWC	6753	Load Word Count Register
		Loads WC register from AC, then clears the AC
DLCA	6755	Load Current Address Register
		Loads CA register from AC; then clears the AC
DRCA	6757	Read Current Address Register
		Clears the AC; then reads the contents of the CA register into the AC.

SIZE A	CODE SP	NUMBER RK01-0-6	REV
------------------	------------	--------------------	-----

TITLE		
<u>Programming Instructions - Detailed Description</u>		
<u>DLDC - 6732</u>		
The command register is loaded from the AC. The AC is cleared.		
AC bit usage is as follows:		
AC Bits	0	This bit allows changes to the interrupt status if it is a "1". If it is "0", the interrupt status cannot be changed except by DCLA.
	1	If a "1" and bit 0 is a "1", set the enable gate to allow a program interrupt when the Transfer Done flag = "1".
		If a "0" and bit 0 is a "1", reset the enable gate.
	2	If a "1" and bit 0 is a "1", set the enable gate to allow a program interrupt when the error flag = 1.
		If a "0" and bit 0 is a "1", reset the enable gate.
	4	If a "1", seek the track specified in track address register, but do not start transfer. If a "0", seek the track, surface, sector and start the transfer.

SIZE A	CODE SP	NUMBER RK01-0-6	REV
------------------	------------	--------------------	-----

000000

CONTINUATION SHEET

TITLE

- 5 If a "1", the header is accessible to the programmer.
- Read The two header words plus data are read. The maximum number of words read is 258. The work count register determines the minimum number of words.
- Write The two header words plus data are written. The protect switch must be off. When the header words are changed data in that sector must also be rewritten. Maximum/minimum number of words is the same as in read. Since the protection bit is rewritten, formatting is also the method used to "sector protect" an area of the disk.
- Therefore, the program used to protect areas of the disk must be capable of formatting the disk and checking that the sector(s) of the disk does not have irregularities that will cause read errors.
- 6 Extended memory address 0.
- 7 Extended memory address 1.
- 8 Extended memory address 2.
- 9 & 10 00 = Disk 0
01 = Disk 1
10 = Disk 2
11 = Disk 3
- 11 Reserved for future twice density disks 0 = lower tracks, 1 = upper tracks.

SIZE	CODE	NUMBER	REV
A	SP	RK01-0-6	

000000

CONTINUATION SHEET

TITLE

- DLDR or DLDW or DCHP Load track address, surface and sector address from accumulator. The control will execute the command register instructions. If track seek only has been selected, the Transfer Done flag will be set when the correct track is reached. The Transfer Done flag will also be set when transfer is complete.
- DLDR - 6733 Read After the correct track, surface and sector number is found, (see write below) the control will read the second header word. Bit zero of this word is ignored. If any of bits 9-11 are set, the Sector No Good flag is set, and the read operation is terminated.
- DLDW - 6735 Write The first word of the header is the track, surface and sector address. It is read by the control and compared with the selected address. If the track addresses differ, the Address Error flag is set and the write operation is terminated. If the two addresses are the same, the sector addresses are checked. If they are the same, the second header word is checked. If the sector addresses are not the same the next sector header is read. This continues until the correct sector is found.
- If bit zero of the second header word is a "1", and the sector protect switch is on, the sector is protected and the write lock error flag will be set and the transfer terminated immediately. If the bit is a "0" the rest of the header word is checked.

SIZE	CODE	NUMBER	REV
A	SP	RK01-0-6	

CONTINUATION SHEET				
TITLE				
				If one of bits 1-5 of the second header word is a "1", the sector has a permanent error and the Sector No Good flag will be set. The writing operation will be terminated. Bits 6-11 are unused.
	6737			The specified sector of the disk is read for correct parity. The parity error flag will be set if there is an error, transfer will be terminated, the transfer done flag will be set.
DRDA	6734			Clear accumulator and read track, surface and sector counter into the accumulator. This is a dynamic register and is changing if a new track or surface has been selected. The sector counter changes every 5 milliseconds. The program must read these counters twice and verify that the information is correct.
DCRCD	6736			Clear accumulator and read command register into accumulator.
DRDS	6741			Clear accumulator and read status register into accumulator.
	AC Bits			
	0			Error
				This flag is set when any error flags are set. Control operation ceases whenever the error flag is set, the transfer done flag is set to "1" and the busy flag to "0".
	1			Transfer Done - set whenever a control operation is terminated.
		SIZE	CODE	NUMBER
		A	SP	RK01=0-6
				REV

CONTINUATION SHEET				
TITLE				
	2			Control Busy Error - Disk IOT issued when control busy which would effect operation.
	3			Time Out Error - The control did not complete and operation after 2 seconds.
	4			Parity Error or Timing Bit Error. A bit in data, parity or timing has been picked up or dropped on read. The word count, current address information can be used to identify the error.
	5			Data Rate Error - The processor was busy and did not respond to a data break request within the 13 microseconds required.
	6			Track Address Error - Track, surface or sector address read from the disk did not agree with the address count registers.
	7			Sector No Good - The program attempted to read or write data on a sector whose header words indicated a bad sector.
	8			Write Lock Error - The program attempted to write a section that was write protected.
	9			Track Capacity Exceeded Error - The program attempted to read or write beyond sector 15.
	10			Select Error - Non existant drive error position error or drive. Not ready error.
		SIZE	CODE	NUMBER
		A	SP	RK01=0-6
				REV



CONTINUATION SHEET

TITLE

11 Busy = 1 - This flag is in the one state when the control is busy. When it goes to the zero state, the transfer done flag will be set.

DMNT 6743 AC bit 0-5, 7-8 are self-explanatory.

Bit 6 Writes a block of memory specified by word count and current address without formats. Writing starts immediately after the sector mark and continues until the word count overflows. Two extra words are written at the beginning of the block of information. These words are the contents of the data register prior to initiating write.

A read operation reads all data after a sector mark until the word count overflows.

This ability to read or write any format gives some degree of interchangeability between drives using different format. With bit 6 = 1, the format written is generated by program. Any format can be read and decoded if one knows the format that was read.

DLDA, DCLS, DCLA, DSKD, DSKT, DSKB, DRWE, DLWC, DLCA, DRCA are self-explanatory.

SIZE	CODE	NUMBER	REV
A	SP	RK01-0-6	

TITLE RK08 Acceptance Procedure

the following test patterns:

TST	PAT	DLS	SEQ
1	4	2	∅
6	4	2	1
3	6	3	1
4	3	1	∅
5	3	1	1
3	9	3	1
3	7	2	1
4	9	2	∅
5	9	1	∅
4	9	3	∅
5	9	1	1
2	8	1	∅
6	8	1	1
3	5	3	1
3	9	1	∅
2	3	1	∅
6	3	1	∅
5	3	2	1
∅	1	1	∅
7	1	1	1
3	7	2	1
∅	∅	1	∅
7	∅	1	1
3	∅	∅	1
3	1	∅	1
3	3	1	1
3	4	1	1
3	5	2	1
3	6	2	1
3	7	3	1
3	9	3	1

NOTE: Be sure that the patterns are in correctly. A typing error may cause an erroneous print out. Three pass complete type outs are necessary for this test to be accepted.

7) This test is to check for a power failure destroying data. Call the "Test" mode of data reliability. Select all the units on the system and run this pattern:

TST	PAT	DLS	SEQ
3	1	1	∅

SIZE	CODE	NUMBER	REV
A	SP	RK01-0-7	

TITLE RK08 Acceptance Procedure

When the pass complete type out occurs stop the program and restart the test. Select the test mode again and one of the drives on the system. Call in the following pattern:

TST	PAT	DLS	SEQ
6	1	1	∅

While this is running, throw the selected drive "start-stop" switch to stop. Ignore the program type out and stop the computer when the drive becomes safe restart the drive by flipping the switch to start. When the drive is up to speed (indicated by the selection switch being on) restart the program and select the same unit and pattern:

TST	PAT	DLS	SEQ
6	1	1	∅

Test the simulated power failure on each of the remaining drives on the system.

8) Check the write lock-out switches in the following manner. Call up the following test pattern from the test mode of the data reliability diagnostic:

TST	PAT	DLS	SEQ
4	∅	∅	∅

While this is running, hit any lock-out switch that pertains to a drive on the system. An error type out should occur. Inspect the type out to be sure that the drive that failed corresponds with the switch that was hit. Repeat the test on all the drives on the system.

9) There must be complete compatibility between all RK08 disk drives. Acceptance for this is run by formatting a customer cartridge on a drive not associated with the system being accepted and running the "accept" mode of the data reliability diagnostic for twenty (20) minutes on each drive on the system.

10) The final acceptance test is to run the system software for the type computer that the disk is on; PDP-8, 8I, 8L must run PS-8 software; PDP-12 must run LAP-6 Dial Mass Storage.

11) Special hardware to go with the RK08 system: All items listed on A-AL-RK01-0-3.

12) Software to go with the RK08 System and 8K of memory: All items listed on A-SL-RK01-0-4.

SIZE	CODE	NUMBER	REV
A	SP	RK01-0-7	