

DWTVX-Ax VME I/O Subsystem

Pocket Service Guide

Order Number: EK-DWTVX-PS.A01

Prepared by
Information Design and Consulting

Digital Equipment Corporation • Merrimack, NH 03054

1st Edition, August 1992

© Digital Equipment Corporation 1992
All Rights Reserved

The information in this document is subject to change without notice and should not be construed as a commitment by Digital Equipment Corporation. Digital Equipment Corporation assumes no responsibility for any errors that may appear in this document.

No responsibility is assumed for the use or reliability of software on equipment that is not supplied by Digital Equipment Corporation or its affiliated companies.

Restricted Rights: Use, duplication, or disclosure by the U.S. Government is subject to restrictions set forth in subparagraph (c)(1)(ii) of the Rights in Technical Data and Computer Software clause at DFARS 252.227-7013.

Printed in U.S.A.
All Rights Reserved.

DEC, DECUS, DECsystem, DECstation, DECwindows, PDP, TURBOchannel, VAX, VMS, and the DIGITAL logo are trademarks of Digital Equipment Corporation.

Table of Contents

- Chapter 1 System Overview** **1**
 - 1.1 Introduction 1
 - 1.2 T6000-AA Module Jumper and Switch Settings 1
 - 1.3 Diagnostic Tests 2

- Chapter 2 VME Test Module (P/N FC-10169-AC)** **5**
 - 2.1 General 5
 - 2.2 VME Test Module Configuration 5
 - 2.2.1 Disable VME Test Module System Controller Functions 6
 - 2.2.2 Enable VME Test Module System Controller Functions 6
 - 2.3 VME Test Module Installation 9

- Chapter 3 Removal and Replacement Procedures** **11**
 - 3.1 PMABV-AA Module 11
 - 3.2 T6000-AA Module 11
 - 3.2.1 T6000-AA Jumper for System Controller Functions 11
 - 3.2.2 T6000-AA Operating Mode and Address Ranges 12

- Chapter 4 Diagnostics** **17**
 - 4.1 Introduction 17
 - 4.2 PMABV-AA Module Diagnostic Tests 22
 - 4.2.1 pmabv_csr Test 22
 - 4.2.2 Loopback Test 22
 - 4.3 T6000-AA Module Diagnostic Tests 23
 - 4.3.1 t6_csr Test 23
 - 4.3.2 t6_reset Test 23
 - 4.3.3 pio_exer Test 23
 - 4.3.4 dma_exer Test 24
 - 4.3.5 vic_test Test 24
 - 4.4 VME Test Module Diagnostic Test 25
 - 4.4.1 vme_access Test 25
 - 4.4.2 VME Cycle Tests (VCT) 26
 - 4.5 Power-Up Self-Tests 28

Tables

Table 2-1 VME Test Module Default Configuration	5
Table 3-1 T6000-AA Settings for A24 Mode and Address Ranges	13
Table 3-2 T6000-AA Settings for A32 Mode and Address Ranges	14
Table 3-2 T6000-AA Settings for A32 Mode and Address Ranges (Continued) ...	15
Table 4-1 Quick Reference to DWTVX-Ax Diagnostics	29

Figures

Figure 1-1 Hardware Configuration	3
Figure 2-1 VME Test Module System Controller Configurations	7
Figure 2-2 VME Test Module Default Configurations	8
Figure 3-1 T6000-AA Module	11
Figure 4-1 Diagnostic Flow Chart, PMABV-AA Module Test	18
Figure 4-2 Diagnostic Flow Chart, Interconnect Cable Test	19
Figure 4-3 Diagnostic Flow Chart, T6000-AA Module Test	20
Figure 4-3 Diagnostic Flow Chart, T6000-AA Module Test (continued)	21

Chapter 1

System Overview

1.1 Introduction

The DWTVX-Ax VME I/O subsystem for the DECstation 5000 models 100, 125, 133, 200 and 240 ; DECsystem 5900 and Personal DECstation 5000 models 20, 25 and 33 (host systems) consists of the following:

- PMABV-AA VME Adapter Module (P/N 54-20085-01) for the TURBO channel, which is installed in the host system.
- T6000-AA VME Controller Module (P/N 54-20087-01), which is installed in a separate subrack or enclosure that contains a VME backplane conforming to the IEEE 1014-1987 Standard.
- An interconnect cable (P/N 17-03007-01), which connects the two modules together.
- Two interconnect cables (P/N 17-03009-01 and P/N 17-03010-01), which are used to configure the DWTVX-Ax VME I/O subsystem in a BA62 enclosure, as shown in Figure 1-1.

1.2 T6000-AA Module Jumper and Switch Settings

The T6000-AA Module has a jumper that determines whether the module operates as the VME bus system controller. Refer to Section 3.2.1.

If more than one T6000-AA Module is installed in the same VME bus, the 6-position switch on each T6000-AA Module must be set. Refer to Section 3.2.2.

1.3 Diagnostic Tests

VME diagnostic tests consist of a series of three test procedures. These test procedures are used to check the operation of both the PMABV-AA and T6000-AA modules, and the interconnect cable. These test procedures consist of:

- PMABV-AA Module diagnostic tests (refer to Section 4.2).
- T6000-AA Module diagnostic tests (refer to Section 4.3).
- VME Test Module diagnostic tests (refer to Section 4.4).

A VME Test Module (P/N FC-10169-AC) is used to extend the diagnostic test coverage of the DWTVX-Ax VME I/O subsystem. This module is installed in the VME backplane as shown in Figure 1-1.

A loopback connector (P/N 12-35537-01) is shipped with each DWTVX-Ax VME I/O subsystem. The loopback connector is either connected directly to the PMABV-AA Module, or to the end of the interconnect cable (in place of the T6000-AA module). In this way, a loopback diagnostic test can be used to troubleshoot both the PMABV-AA Module and the interconnect cable.

Note

Test results will be unpredictable if individual diagnostic tests are executed without connecting the loopback connector or the T6000-AA Module to the PMABV-AA VME Adapter Module.

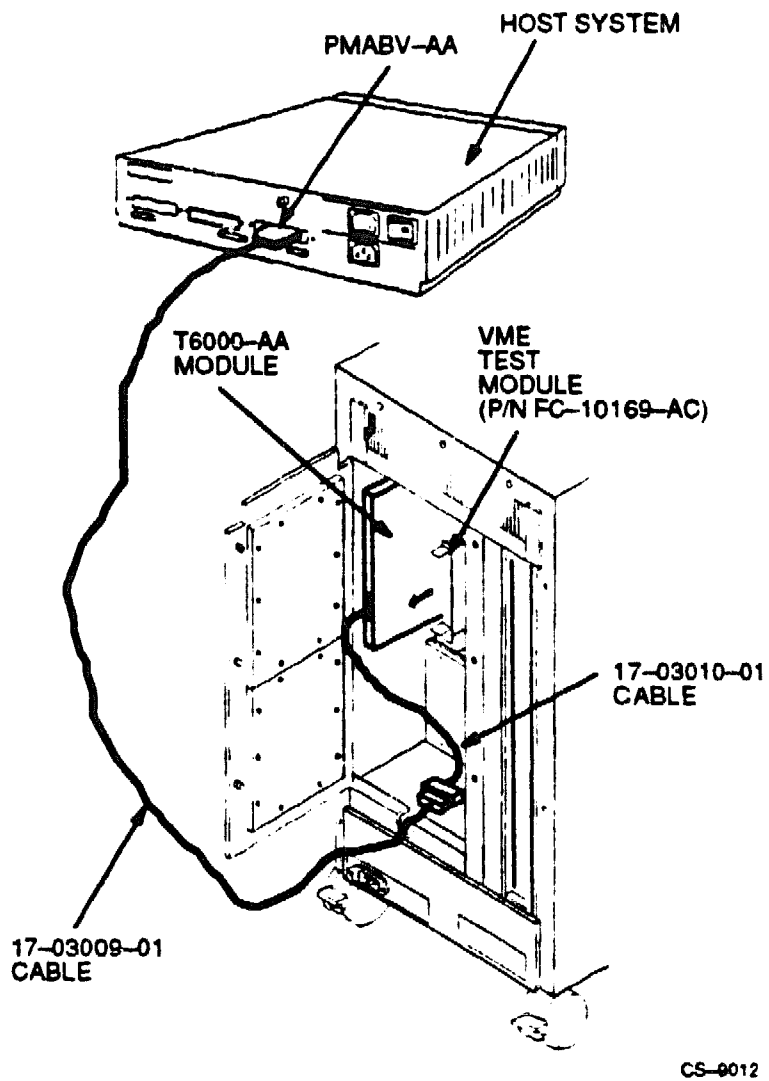

Figure 1-1 Hardware Configuration

PLATE

Chapter 2 VME Test Module (P/N FC-10169-AC)

2.1 General

The VME Test Module is a VME single-board computer that is used to extend the diagnostic test coverage of the DWTVX-Ax VME adapter. Diagnostics are loaded from the host system and then executed by the VME Test Module.

2.2 VME Test Module Configuration

The VME Test Module has been preset for use with the DWTVX-Ax VME adapter. The switch and jumper settings that differ from the standard factory defaults (documented in the manual supplied with the VME Test Module) are listed in Table 2-1 (also refer to Figures 2-1 and 2-2).

Table 2-1 VME Test Module Default Configuration

Component	Setting/Description
Switches	
(SW5)	Set to position 8
(SW7)	Set to position 8
(SW6)	Set to position B
(SW4)	Set to position 8
Jumpers (links)	
LK10	Not installed
LK30	Installed
LK13 - LK14	RTC not installed

2.2.1 Disable VME Test Module System Controller Functions

To *disable* the onboard system controller functions on the VME Test Module, ensure that Jumper (link) LK10 is not installed and that Jumper (link) LK30 is installed (see Figure 2-1). This is the default configuration and is used during testing when the T6000-AA Module is set up as a VME system controller, as described in Section 3.2.1.

2.2.2 Enable VME Test Module System Controller Functions

To *enable* the onboard system controller functions on the VME Test Module, ensure that Jumper (link) LK10 is installed and that Jumper (link) LK30 is not installed (see Figure 2-2). This configuration is used when the T6000-AA Module is not set up as VME system controller, as described in Section 3.2.1.

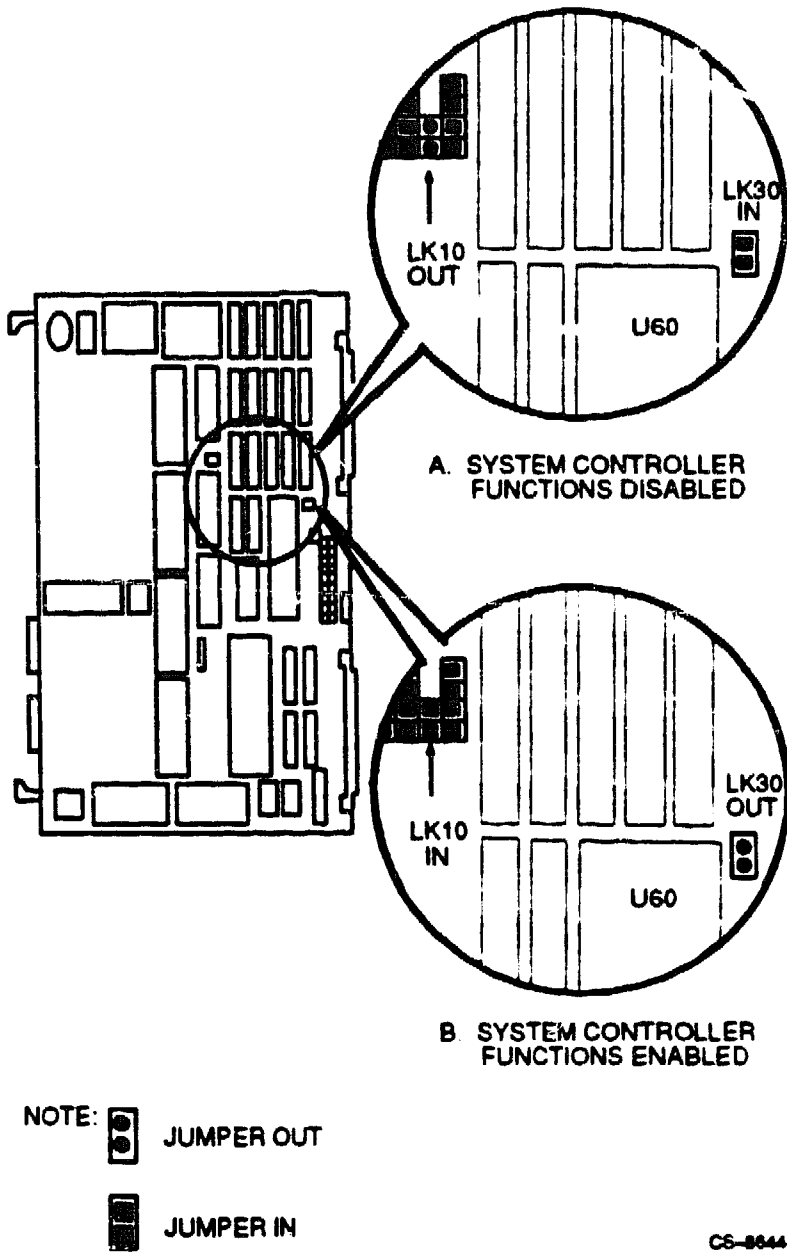
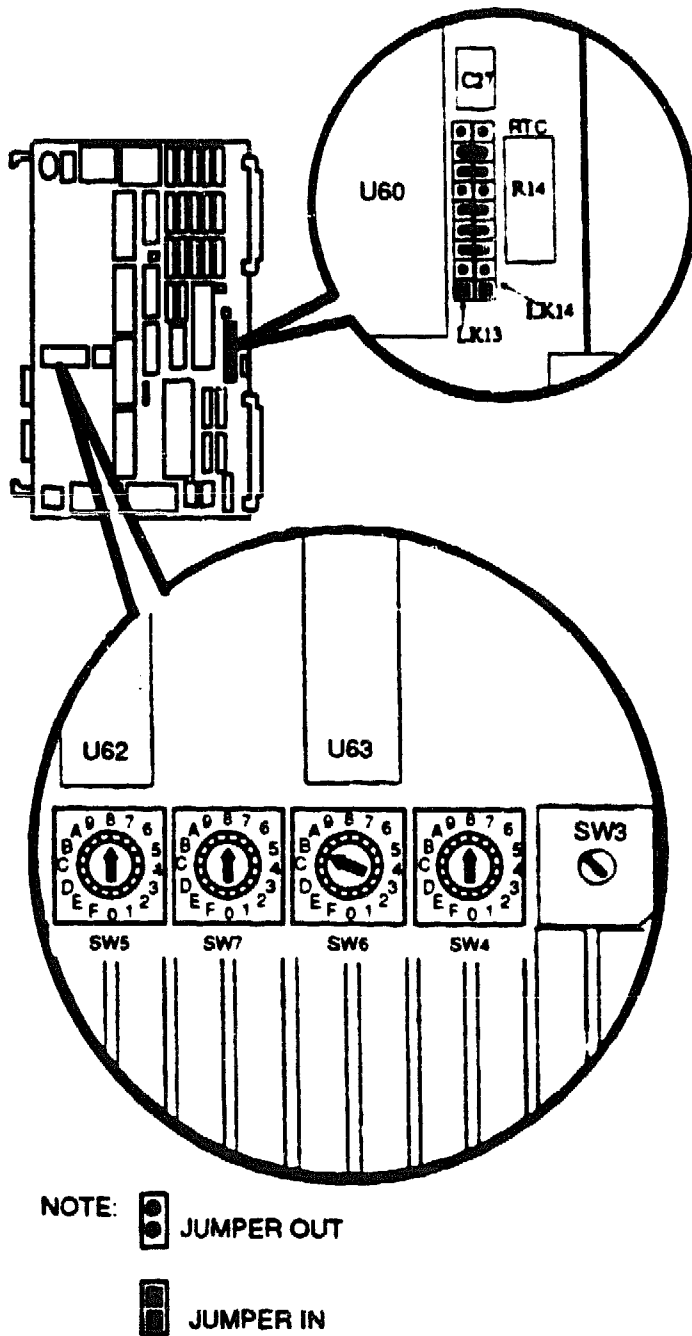

Figure 2-1 VME Test Module System Controller Configurations



CS-8645C

Figure 2-2 VME Test Module Default Configurations

2.3 VME Test Module Installation

To confirm that the T6000-AA VME Controller Module is functioning properly, all third-party options from the VME card cage must be removed before installing the VME Test Module. Otherwise, other modules may become active at power-up, and their status or activity is unknown. Perform the steps listed below to install the VME Test Module.

CAUTION

Use appropriate antistatic protection before handling any modules.

1. Back out (do not remove from card cage) all third-party VME option modules, except the T6000-AA Module, from the VME card cage backplane.
2. If the T6000-AA Module is configured to perform system controller functions (Jumper IN), refer to the *BA62 VME Enclosure Pocket Service Guide* (EK-VME01-PS), then perform the following steps:
 - a. Configure the VME Test Module (see Section 2.2.1 and Figure 2-1).
 - b. Install the VME Test Module in any backplane position other than position 1.
 - c. Proceed to step 3.

If the T6000-AA Module is not configured to perform system controller functions (Jumper OUT, refer to the *BA62 VME Enclosure Pocket Service Guide* (EK-VME01-PS), then perform the following steps:

- a. Configure the VME Test Module (see Section 2.2.2 and Figure 2-2).
- b. Install the VME Test Module in backplane position 1.
3. Ensure that the bus grant jumpers (BG00-03 and IACK) are installed in all empty backplane positions between the VME Test Module and the T6000-AA Module.

These jumpers (P/N 12-18783-00) should have been saved after module installation.

Blank

Chapter 3 Removal and Replacement Procedures

3.1 PMABV-AA Module

Refer to *PMABV Module Installation/Owner's Card* (EK-PMABV-IN) to remove or replace the PMABV-AA Module.

3.2 T6000-AA Module

Refer to *T6000 Module Installation/Owner's Card* (EK-T6000-IN) to remove or replace the T6000-AA Module. For information on setting operating modes and address ranges, refer to Sections 3.2.1 and 3.2.2.

3.2.1 T6000-AA Jumper for System Controller Functions

There is one user-selectable jumper on the T6000-AA Module (see Figure 3-1) that enables or disables the the functioning of the module as the system controller in slot 1 on a VME bus. When the jumper is installed, the module can be installed in slot 1 and function as the system controller. Without the jumper, the module does not function as a system controller and can be installed in any slot except slot 1.

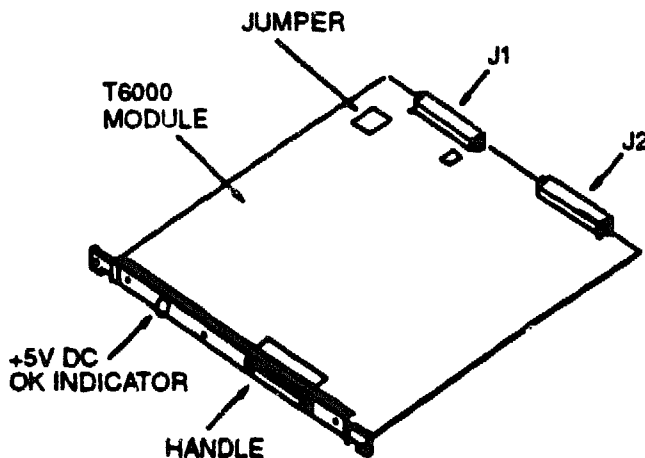

NOTE: JUMPER IN - ALLOWS T6000 TO PERFORM SYSTEM CONTROL FUNCTIONS.
JUMPER OUT - T6000 DOES NOT PERFORM SYSTEM CONTROL FUNCTIONS.

CS-8190

Figure 3-1 T6000-AA Module

3.2.2 T6000-AA Operating Mode and Address Ranges

The T6000-AA Module has one switch block with six switches (T6000-AA address decode switches). The setting of these switches, along with the software setting of the ASC[1:0] bits in the "B" CSR of the T6000-AA Module, allow the operation of up to 32 T6000-AA Modules on a single VME bus.

NOTE

The T6000-AA address decode switches are factory set for the operation of a single T6000-AA Module on a VME bus. Depending on the mode of operation (A24 or A32 mode) selected by the setting of the ASC[1:0] bits of each T6000-AA Module, up to 4 T6000-AA Modules (A24 mode) or 32 T6000-AA Modules (A32 mode) can operate on a single VME bus.

The T6000-AA address decode switches set the addressing range of the T6000-AA Module. Each T6000-AA Module on the VME bus must have its own addressing range as determined by the switch settings. The switches are preset at the factory to all zeros, address range 00000000 - 07FFFFFFF (hexadecimal). This is the setting for operating a single T6000-AA Module on the VME bus.

To set the ASC[1:0] bits and the T6000-AA address decode switches, refer to Table 3-1 for A24 mode and Table 3-2 for A32 mode.

Table 3-1 T6000-AA Settings for A24 Mode and Address Ranges

ASC [1:0]	T6000-AA Switches						
Bits*	S1	S2	S3	S4	S5	S6	Address Range (Hexadecimal)
1 1	0	x	x	x	x	0	000000 - 3FFFFFF
0 0	0	x	x	x	x	0	000000 - 3FFFFFF
1 1	0	x	x	x	x	1	400000 - 7FFFFFF
0 0	0	x	x	x	x	1	400000 - 7FFFFFF
1 1	1	x	x	x	x	0	800000 - BFFFFFF
0 0	1	x	x	x	x	0	800000 - BFFFFFF
1 1	1	x	x	x	x	1	C00000 - FFFFFFF
0 0	1	x	x	x	x	1	C00000 - FFFFFFF

* The ASC[1:0] bits located in the "B" CSR of the T6000-AA must be set to either a 11 or 00. Other combinations of the ASC [1:0] bits are reserved.

Table 3–2 T6000–AA Settings for A32 Mode and Address Ranges

ASC [1:0]	T6000–AA Switches						
Bits*	S1	S2	S3	S4	S5	S6	Address Range (Hexadecimal)
11 or 00	0	0	0	0	0	x	00000000 – 07FFFFFFF
	0	0	0	0	1	x	08000000 – 0FFFFFFF
	0	0	0	1	0	x	10000000 – 17FFFFFFF
	0	0	0	1	1	x	18000000 – 1FFFFFFF
	0	0	1	0	0	x	20000000 – 27FFFFFFF
	0	0	1	0	1	x	28000000 – 2FFFFFFF
	0	0	1	1	0	x	30000000 – 37FFFFFFF
	0	0	1	1	1	x	38000000 – 3FFFFFFF
	0	1	0	0	0	x	40000000 – 47FFFFFFF
	0	1	0	0	1	x	48000000 – 4FFFFFFF
	0	1	0	1	0	x	50000000 – 57FFFFFFF
	0	1	0	1	1	x	58000000 – 5FFFFFFF
	0	1	1	0	0	x	60000000 – 67FFFFFFF
	0	1	1	0	1	x	68000000 – 6FFFFFFF
	0	1	1	1	0	x	70000000 – 77FFFFFFF
	0	1	1	1	1	x	78000000 – 7FFFFFFF

* The ASC[1:0] bits located in the "B" CSR of the T6000–AA must be set to either a 11 or 00. Other combinations of the ASC [1:0] bits are reserved.

**Table 3-2 T6000-AA Settings for A32 Mode and Address Ranges
(Continued)**

ASC [1:0]	T6000-AA Switches						
Bits*	S1	S2	S3	S4	S5	S6	Address Range (Hexadecimal)
11 or 00	1	0	0	0	0	x	80000000 - 87FFFFFFF
	1	0	0	0	1	x	88000000 - 8FFFFFFF
	1	0	0	1	0	x	90000000 - 97FFFFFFF
	1	0	0	1	1	x	98000000 - 9FFFFFFF
	1	0	1	0	0	x	A0000000 - A7FFFFFFF
	1	0	1	0	1	x	A8000000 - AFFFFFFF
	1	0	1	1	0	x	B0000000 - B7FFFFFFF
	1	0	1	1	1	x	B8000000 - BFFFFFFF
	1	1	0	0	0	x	C0000000 - C7FFFFFFF
	1	1	0	0	1	x	C8000000 - CFFFFFFF
	1	1	0	1	0	x	D0000000 - D7FFFFFFF
	1	1	0	1	1	x	D8000000 - DFFFFFFF
	1	1	1	0	0	x	E0000000 - E7FFFFFFF
	1	1	1	0	1	x	E8000000 - EFFFFFFF
	1	1	1	1	0	x	F0000000 - F7FFFFFFF
	1	1	1	1	1	x	F8000000 - FFFFFFFF

* The ASC[1:0] bits located in the "B" CSR of the T6000-AA must be set to either a 11 or 00. Other combinations of the ASC [1:0] bits are reserved.

١٦

Chapter 4 Diagnostics

4.1 Introduction

The diagnostics provided with the PMABV-AA VME Module troubleshoot the PMABV-AA Module, the T6000-AA VME Controller Module, and the interconnect cable.

Note

Diagnostics for non-Digital (third-party) VME modules are not provided by Digital. Support for those modules is beyond the scope of this manual.

Table 4-1 provides quick reference to the DWTVX-Ax diagnostics. Figures 4-1 through 4-3 are diagnostic flow charts of the DWTVX-Ax diagnostics. These figures show the sequential test procedures for the PMABV-AA Module, the T6000-AA VME Controller Module, and the interconnect cable tests.

Note

Power-up tests and references to Table 4-1 frequently indicate the failing module (PMABV-AA or T6000-AA). The diagnostic flow charts should be used when power-up tests do not isolate the failing component.

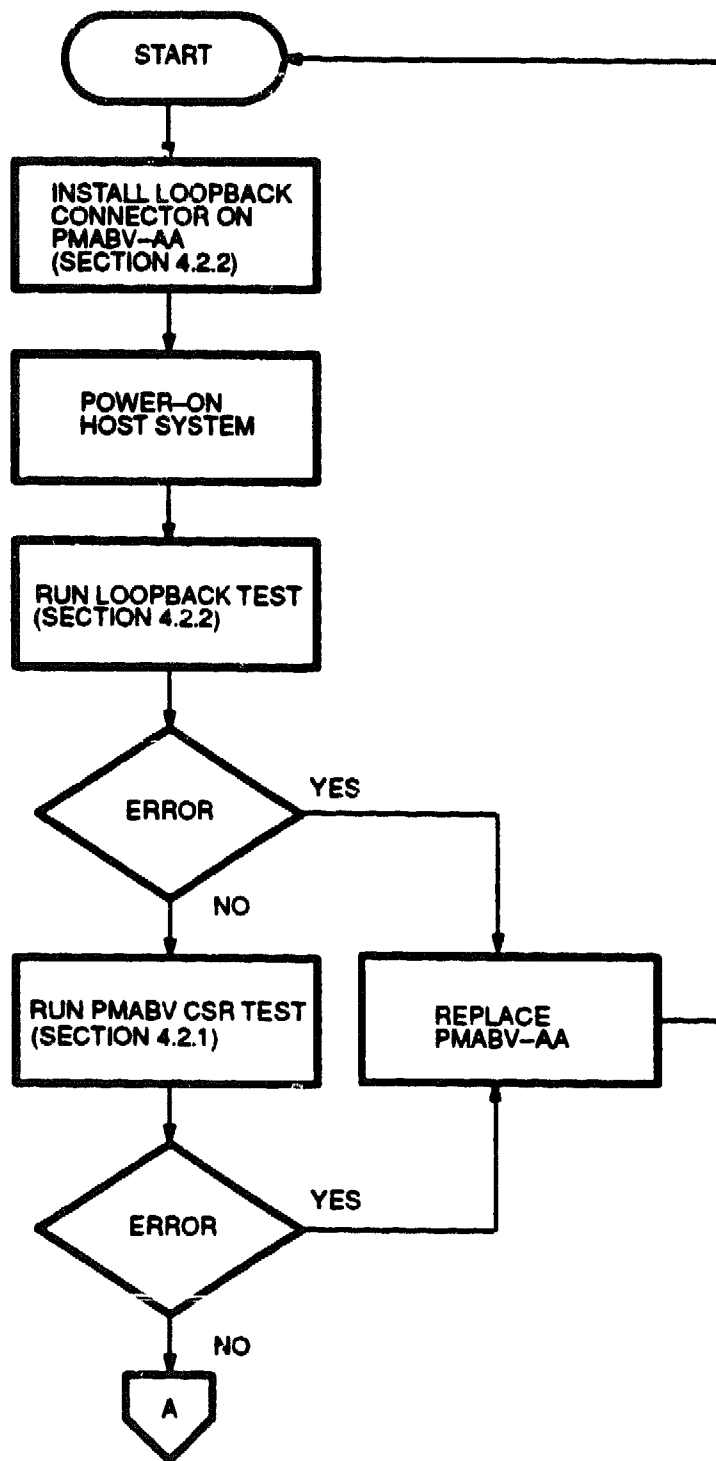

CS-0008

Figure 4-1 Diagnostic Flow Chart, PMABV-AA Module Test

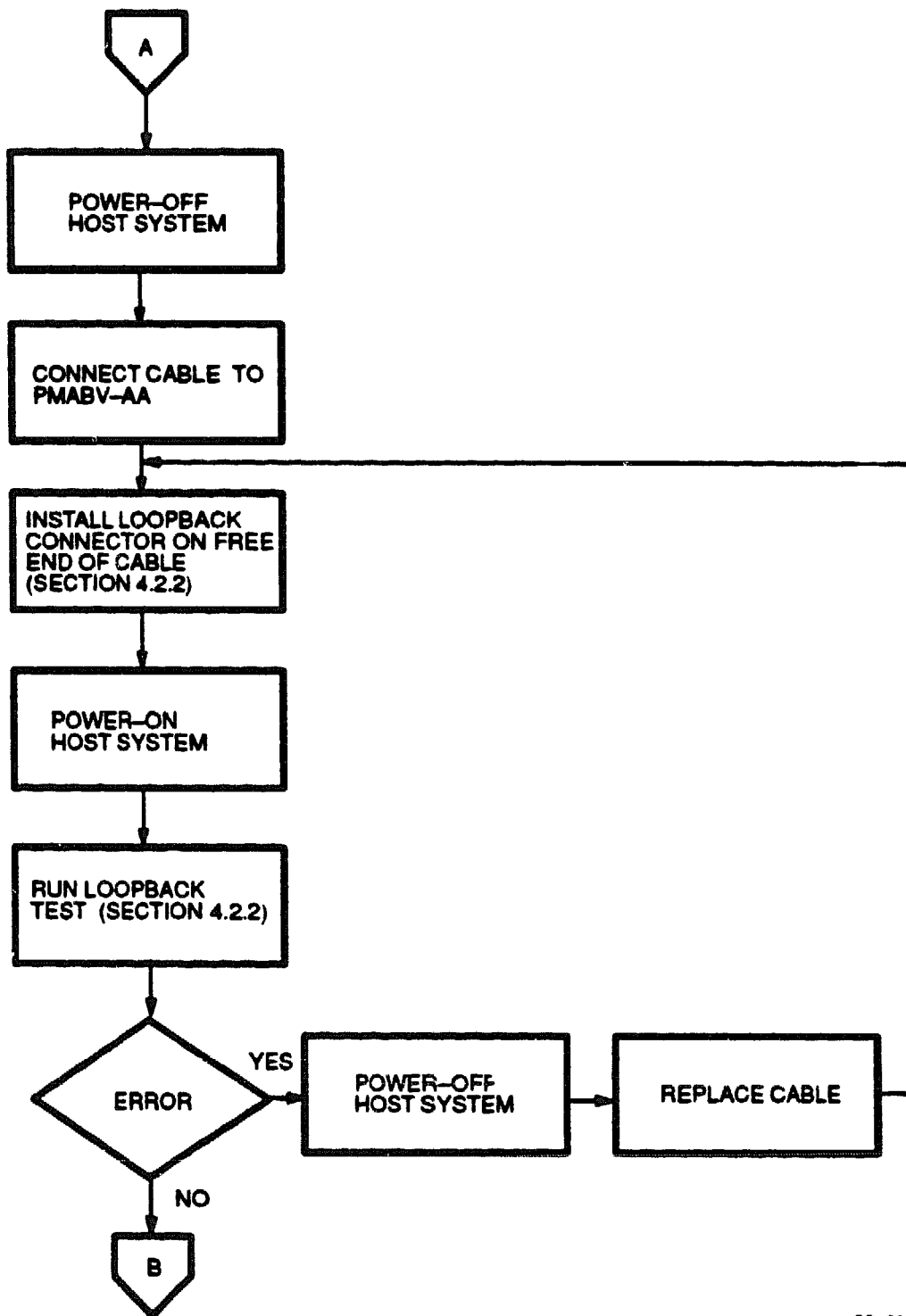

CS-6006

Figure 4-2 Diagnostic Flow Chart, Interconnect Cable Test

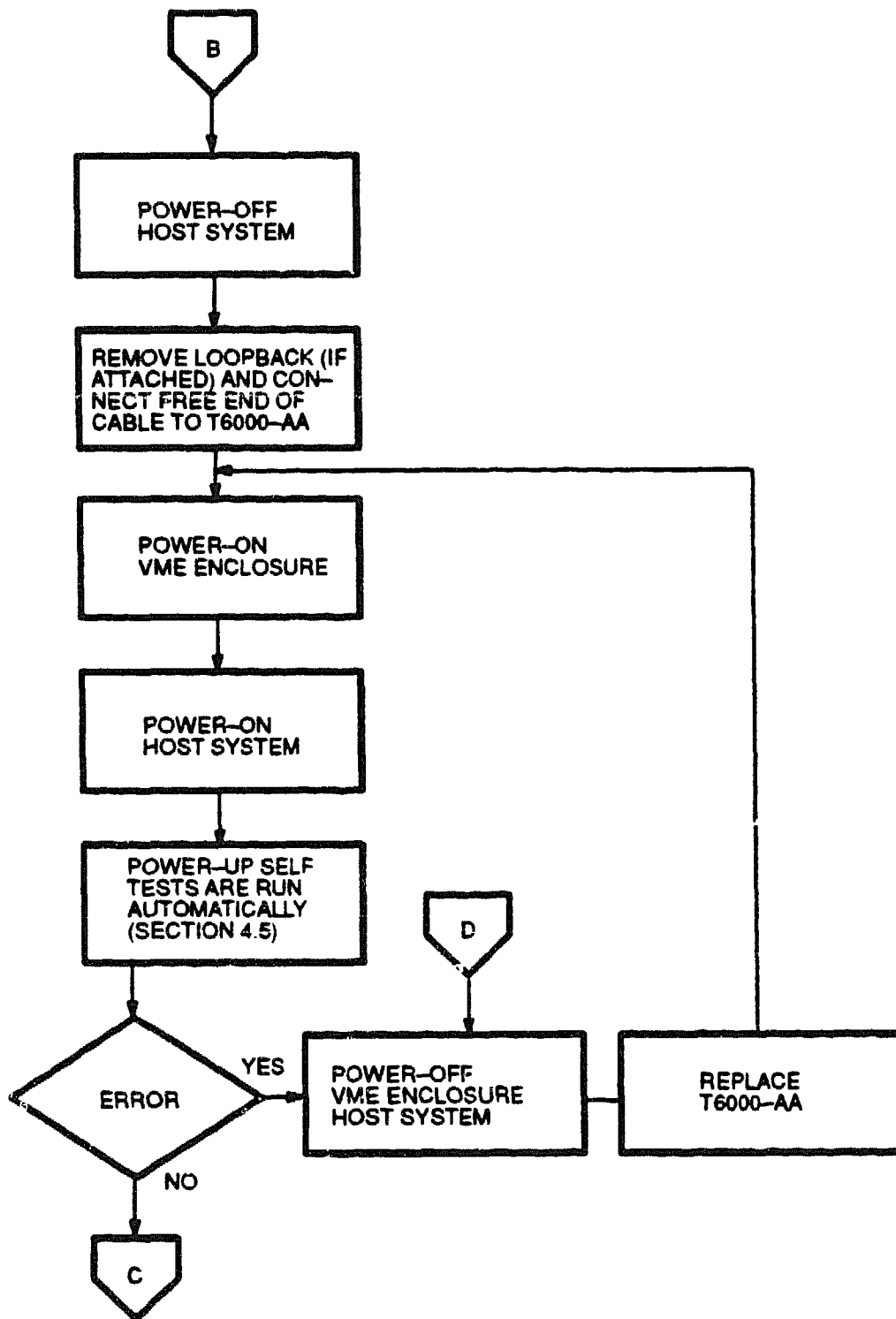

CS-0010

Figure 4-3 Diagnostic Flow Chart, T6000-AA Module Test

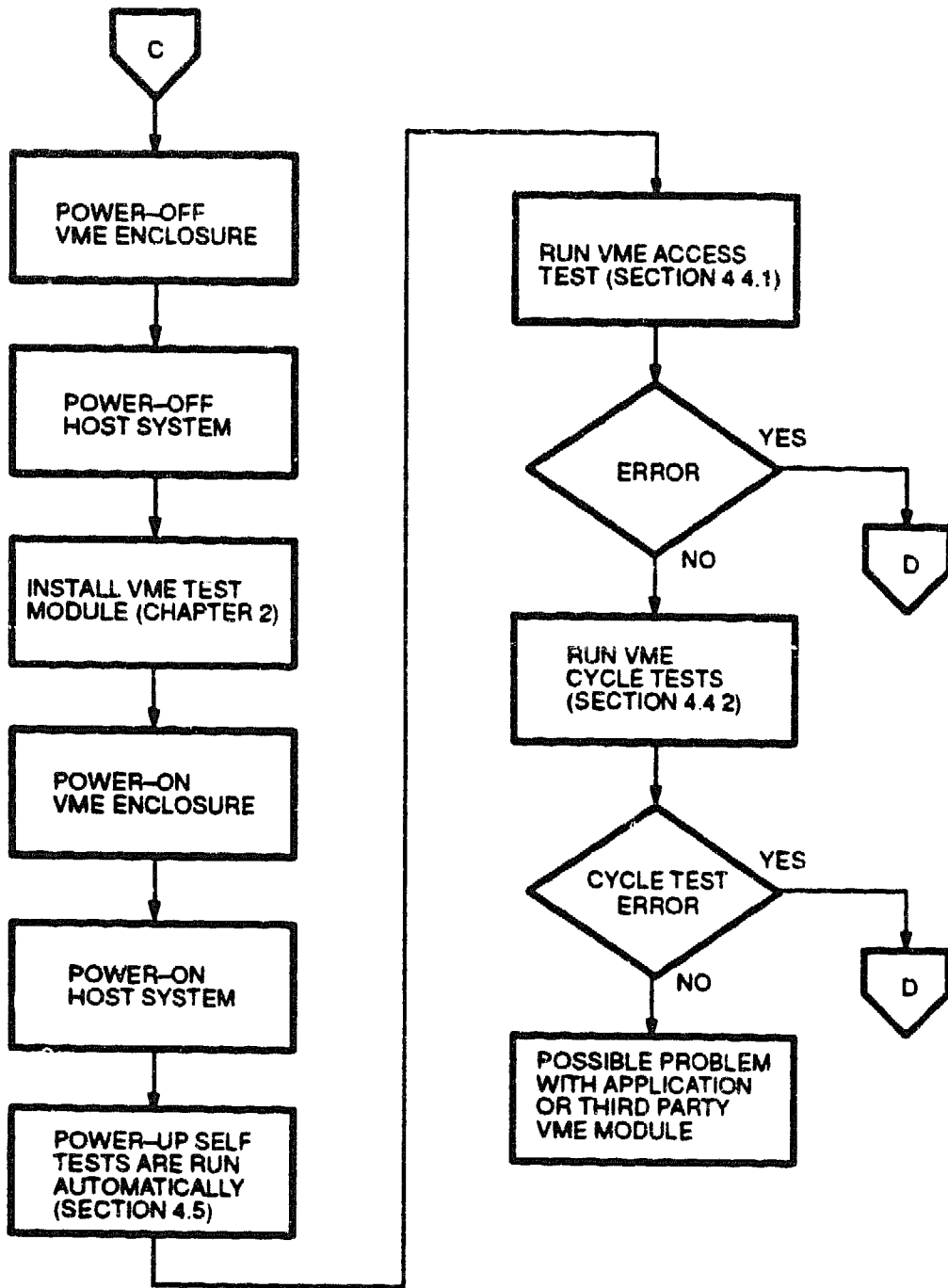

CS-0058

Figure 4-3 Diagnostic Flow Chart, T6000-AA Module Test (continued)

4.2 PMABV-AA Module Diagnostic Tests

These diagnostic tests are used to troubleshoot the PMABV-AA module, and optionally, the interconnect cable. These tests are invoked automatically at power-up and can also be invoked individually. Refer to Table 4-1 and to Figures 4-1 and 4-4.

Note

Bold type indicates user entry.

4.2.1 pmabv_csr Test

The `pmabv_csr` test performs a read/write test of the PMABV_AA CSR.

To run the `pmabv_csr` test, enter the following:

```
>>> 2/pmabv_csr  
>> (success)  
?TFL 2/pmabv_csr (fail)
```

4.2.2 Loopback Test

The loopback test performs byte/word/longword read/write tests through the loopback connector (P/N 12-35537-01) to test the PMABV-AA Module, and optionally, the interconnect cable.

To install the loopback connector, perform the following steps:

1. Set the power switch on the host system to the OFF position.
2. Press the loopback connector into the mating connector on the PMABV-AA Module (or onto the free end of the interconnect cable).

Note

The loopback connector is keyed to ensure proper installation.

To run the loopback test, enter the following:

```
>>> 2/loopback  
>> (success)  
?TFL 2/loopback (fail)
```

4.3 T6000-AA Module Diagnostic Tests

These tests troubleshoot the T6000-AA Module. They are invoked automatically at power-up and can also be invoked individually. Refer to Table 4-1 and to Figure 4-3.

Note

Bold type indicates user entry.

4.3.1 t6_csr Test

The t6_csr test performs a read/write test of the T6000-AA CSR.

To run the t6_csr test, enter the following:

```
>>t 2/t6_csr
>> (success)
?TFL 2/t6_csr (fail)
```

4.3.2 t6_reset Test

The t6_reset test performs a reset of the T6000-AA CSR.

To run the t6_reset test, enter the following:

```
>>t 2/t6_reset
>> (success)
?TFL 2/t6_reset (fail)
```

4.3.3 pio_exer Test

The pio_exer test performs a read/write to the T6000-AA Module's memory space.

To run the pio_exer test, enter the following:

```
>>t 2/pio_exer
>> (success)
?TFL 2/pio_exer (fail)
```

4.3.4 dma_exer Test

The dma_exer test performs read/write patterns to the T6000-AA Module's DMA memory space.

To run the dma_exer test, enter the following:

```
>>t 2/dma_exer  
>> (success)  
?TFL 2/dma_exer (fail)
```

4.3.5 vic_test Test

The vic_exer test performs Read/Write to the VME interface chip on the T6000-AA module.

To run the vic_exer test, type in the following:

```
>>t 2/vic_test  
>> (success)  
?TFL 2/vic_test (fail)
```

4.4 VME Test Module Diagnostic Test

These diagnostics use the VME Test Module to increase the test coverage of the T6000-AA Module.

Note

The VME Test Module must be installed in the VME backplane before running these tests (refer to Chapter 2).

4.4.1 vme_access Test

The vme_access diagnostic test performs 4K block pio read/write patterns to the VME Test Module.

Note

Bold type indicates user entry.

To run the vme_access test, enter the following:

```
>>t 2/vme_access
PMR Block Write/Read exerciser
wr/rd _ subtest 0
wr/rd _ subtest 1
wr/rd _ subtest 2
wr/rd _ subtest 3
wr/rd _ subtest 4
wr/rd _ subtest 5
wr/rd _ subtest 6
wr/rd _ subtest 7
wr/rd _ subtest 8
>> (success)
?TFL 2/vme_access (fail)
```

4.4.2 VME Cycle Tests (VCT)

The VME Cycle Tests provide a menu-driven selection of diagnostic tests that require varying levels of test equipment. The VME Test Module available for field use allows service personnel to run a series of concurrent tests that generate two-way traffic between the host system and the VME Test Module.

Note

Bold type indicates user entry.

The Master-25 Radstone must have the *Customer Service* set of PROMs to do this testing. Once the Master has the correct set of PROMs, plug it and the T6000-AA Module into the VME back-plane.

When the YABUS cable is connected to the PMABV-AA Module, power on the VCT. Then power on the host system.

To invoke the host portion, enter the following on the host system:

```
>> t 2/eng
```

Ignore any WARNING messages pertaining to data mismatch in VCT dual port RAM.

VME Cycle Tester for Field Service and Manufacturing Use

1. Inbound Testing (Field Service Use)
2. VME Testing as Slot 1 Controller (MFG Use)
3. VME Testing as Non-Slot 1 Controller (MFG Use)
4. Low End Board Testing (MFG Use)

```
Please enter your choice: 1      Enter '1' to select Inbound Testing
```

```
Which VCT test would you like to run
```

- | | |
|--|---------------------------|
| 1- TST 1: Large Block DMA Writes (68-33) | 21- TST 1 with Interrupts |
| 2- TST 2: Large Block DMA Reads (68-33) | 22- TST 2 with Interrupts |
| 3- TST 3: DMA PMR Read Test (64K chunks) | |
| 4- TST 4: DMA PMR Write Test (64K chunks) | |
| 5- TST 5: 8 mSec Interrupt Test | |
| 6- TST 6: Inbound Concurrent Testing (Field Service use) | |
| 7- TST 7: Block + 1 16 WT DMA (2 W inc.) | |
| 8- TST 8: Block + 1 16 Rd DMA (2 W inc.) | |

Note

You can only run Test 6. Tests 1-5, 7-8, 21 and 22 require different test modules. Test failures will occur if these tests are run without the required test modules.

```
Enter the Subtest Number: 6 Enter 6 to select Inbound Concurrent Testing
H!01.....234
.
.
.
H!01.....234
.
.
.
H!... (etc.)
```

Note the printing of dots (".") on the VCT screen. These indicate that data is being passed to the host system.

Inbound Concurrent Testing performs repeated passes until halted. A pass (H!01.....234) takes from one minute to several minutes to complete, depending on the host system type. Allow three to five passes to complete before halting the test.

To halt the Inbound Concurrent Testing, enter **CTRL C**. The interrupt is processed when the actual test completes. After a few moments the system responds with:

```
?IEX: 2/eng [PMABV-AA] (SIGINT)
>>
```

The test may also be halted by pressing the host system reset switch.

Any one of the following messages indicate that an error has occurred. Press the host system reset switch before attempting to run other diagnostic tests.

```
SI: bus error exception (Data or store)
Sack rcvd to Pended Read
YABUS Error on Idle
YABUS Error during DMA
TURBOchannel error on DMA write
TURBOchannel error on DMA read
Sack rcvd to Pended Write
No YABUS receive clock
YABUS H/W cable fault with Pended Request
YABUS Fail_Req detected
```

4.5 Power-Up Self-Tests

The power-up self-tests are automatically performed at power-up. The `pmabv_csr` test (refer to Section 4.2.1) and all T6000-AA tests except the `vic_test` (refer to Section 4.3.5) are executed.

If the console prompt (`>>`) reappears with no failure messages after all tests have run, then the power-up tests have completed successfully. If failure messages were received, refer to Table 4-1 to isolate the failure.

Table 4-1 Quick Reference to DWTVX-Ax Diagnostics

Test Description Invoke	Error Message	Service Required
PMABV-AA: pmabv_csr loopback	?TFL 2/pmabv_csr ?TFL 2/loopback	Replace PMABV-AA Module
T6000-AA: t6_csr t6_reset pio_exer dma_exer vic_test	?TFL 2/t6_csr ?TFL 2/reset ?TFL 2/pio_exer ?TFL 2/dma_exer ?TFL 2/vic_test	Replace T6000-AA Module
VME Test Module Tests: vme_access VME Cycle Tests	?TFL 2/vme_access (see Section 4.4.1)	Replace T6000-AA Module Check VME Test Module Configuration
System Level: (see Note) Power-up Test	??PMABV: CHECK INTERCONNECT CABLE	<ul style="list-style-type: none"> - Nothing connected to PMABV-AA Module - VME unit not powered on or faulty VME enclosure - Cable not connected to T6000-AA Module - Faulty cable
Cable: loopback	?TFL 2/loopback	Replace cable

Note

Test results will be unpredictable if individual diagnostic tests are executed without the loopback connector or the T6000 module connected to the PMABV-AA VME Adapter Module.