



digital industrial 14/30 controller

PWR ON SYSTEM RUN  
ADDR ERROR BUS ERROR

DEC 4 1973

14 INDUSTRIAL 14 FAMILY OF CONTROLLERS

## **WHO IS DIGITAL EQUIPMENT CORPORATION?**

Today, we're the second largest computer manufacturer in the world in terms of total installations. We got our start back in 1957 building solid state logic modules for testing electronic components. Some of our customers were computer manufacturers, so the step into computers was an easy one for us. Our first systems were small, intimate, innovation machines for university and industrial laboratories. Machines dedicated to monitoring instruments and analyzing experimental data on-line during the day, and to problem solving and designing new experiments at night.

Our on-line, real-time expertise in the laboratory made stepping out onto the factory floor or into the processing plant easier, too. We knew how to interface our digital computers to analog sensing equipment for closed or open loop operation. We also knew how important noise immunity is for control systems, and how essential dependability is to those systems. What's more, we were on the forefront of new technology that saw solid state control logic and, later, programmable controllers earn their place on the floor.

Today, worldwide, DIGITAL has 13,000 employees, more than 130 sales offices, 9 manufacturing plants totalling over 3 million square feet of floor space, a field service force of 2000, and over 25,000 computer installations. We are the world's largest supplier of solid state logic modules (about 3 million a year), and not only the inventor of minicomputers but also the leading manufacturer.

Our product lines have multiplied, too. We offer complete families of computers that range from attache-case size minis to room-filling, dual-processor giants. Four full families in all, plus dozens of dedicated systems. To assure compatibility and performance, we also manufacture most of the terminals and peripherals for each family and dedicated system. And support them with some of the most complete system software available.

Although our first systems were designed for the laboratory, we began tailoring computers for other applications as well. Now, our computers can be found in accounting departments, banks, university comp centers, classrooms, hotels, ships, airplanes, assembly lines, petrochemical plants, pipelines, newspapers, warehouses, TV stations, computer service bureaus, stock exchanges, particle accelerators, and hundreds more applications.

## **THE INDUSTRIAL PROGRAMMABLE CONTROLLER**

DIGITAL's original PDP-14 programmable controller was introduced in 1969 and was the first of its kind developed by any manufacturer. It answered a particular need by industry for more reliable and economical control. During the following year the PDP-14/L was introduced as a lower cost, lower performance version of the original PDP-14. Since their introduction, these two models have proven themselves in hundreds of varied and demanding applications around the world. And as the needs of mass production equipment continued to demand more diversification, DIGITAL responded by offering optional features to the basic PDP-14, but at necessary additional cost.

## **THE NEW GENERATION INDUSTRIAL 14/30 AND 14/35**

The new Industrial 14/30 and 14/35 were developed to incorporate optional features of the original PDP-14 into the basic controller, not only making them more economical but also more powerful than any of their predecessors. As a result, the necessity for purchasing options at additional cost simply is no longer a factor. In brief, the highlights of the Industrial 14/30 and 14/35 are:

- Larger I/O capacity
- I/O achieved in increments of 1
- Larger memory capacity
- Internal functions for timers, retentive memories, and counters in addition to external I/O
- Simple implementation with a display based programming terminal
- Simplified installation and maintenance

The story of how and why the Industrial 14s achieve these new dimensions in programmable control follows.

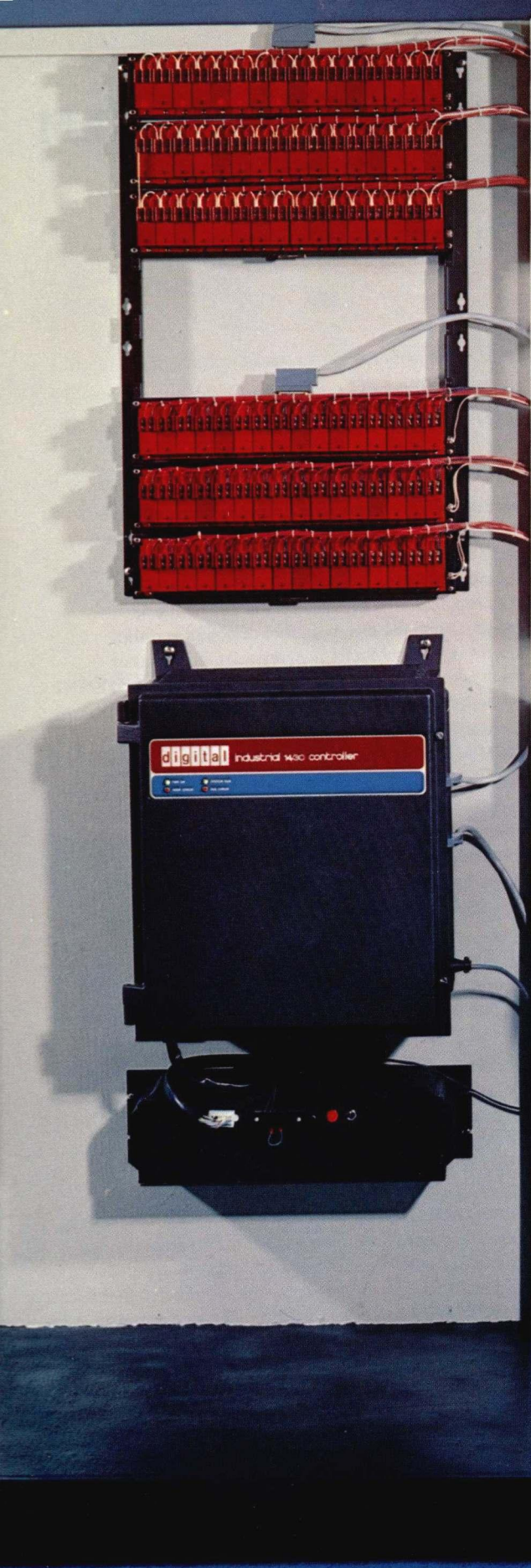

THE INDUSTRIAL 14/30 CONTROLLER WITH ITS VT14 PROGRAMMING TERMINAL

# INPUT/OUTPUT SYSTEM

## INDUSTRIAL 14/30 AND 14/35 OPERATING FEATURES

Memory	14/30—4K words of R/W core memory, second 4K memory can be added. 14/35—8K words of R/W core memory, no memory expansion possible.
Cycle Time	2.5 milliseconds per 1K of control program.
I/O Structure (Expandable one input or output at a time)	Individual converters assembled in groups of 16 on mounting panels. Panels in groups of eight connect through a single cable to control unit.
Inputs (External)	Maximum: 512 Circuit: Optically isolated. AC Rating: 115 VAC; 20-30 mA DC Rating: 10-55 VDC; 20 mA
Outputs (External)	Maximum: 256 Circuit: Transformer isolated. AC Rating: 115 VAC; 2 A steady state; 30 A inrush. DC Rating: 10-55 VDC; 2 A steady state; 8 A inrush.
Internal Functions	Maximum: 256 I/O numbers Type: Retentive memories Shift registers Timers, 0.1 to 99.9 sec. Timers, 1 to 999 sec. Counters, 1 to 999 Up/Down Counters, 1 to 999

The new Industrial 14/30 and 14/35 contain a revolutionary concept in I/O systems for programmable controllers. Where other systems use plug-in modules of 8 or 16 circuits per module, the new 14/30 and 14/35 are capable of single point expansion or replacement. In this way, the 14s neatly fit their applications with the exact number of points and the required mix of voltages. Mechanical replacement is easier because there is no need to disturb wiring to adjacent circuits, as is the case where multiple circuits are on a single board. This design also results in a significant cost savings, by reducing the inventory of spare parts.

Optically isolated inputs separate the internal control unit power from the high voltage control circuits. This protects internal circuitry from line transients and hash. Each plug-in unit integrally contains screw terminals and an indicating light (LED) on the I/O converter to provide a quick means of determining failure within the controller or failure within the machine being controlled.

Beyond the plug-in converters, only printed circuit board conductors, connectors and cables comprise the external I/O. This means that there are no external, high-speed "addressing electronics" to fail, requiring troubleshooting.

Sixteen individual input converters plug into a mounting panel (AC and DC converters can be mixed in a single mounting panel). The mounting panel includes connectors on its top and bottom edges that carry signals to the 14 control unit and onward to successive I/O panels. The first (topmost) input mounting panel is connected to the control unit with a round, multiconductor cable. The top-edge connector of each successive input mounting panel connects to the bottom-edge connector of the panel immediately above it. Eight mounting panels accommodating 128 input points can be interconnected in this manner. Three additional groups of 128 points each are available by using three more cables from the 14/30 (or 14/35) control unit.

Sixteen output drivers (AC or DC) are installed on a mounting panel that is identical to the input panel. The same round multiconductor cable carrying signals to and from the 14 control unit connects to the top most output mounting panel. This cable accommodates 128 points on 8 mounting plates, interconnected through their top and bottom edge connectors. A second group of 128 points can also be connected to the control unit by a second output cable. Thus, the maximum configuration of 512 inputs and 256 outputs requires the simple installation of only six I/O cables.

- Modular substitution for easy maintenance; fewer spares.
- Electrically isolated I/O for internal circuitry protection.
- Indicating lights (LEDs) on the I/O converters to isolate failures.
- I/O multiplexing within the controller for easy expansion.
- No electronics between I/O converters and the controller for simple troubleshooting.
- Only six different parts comprise the I/O system, minimizing spare parts inventory.

## INPUTS

Input devices, such as limit switches, push buttons and photo-cells, are wired to individual plug-in converters. These units incorporate screw terminals for number 14 AWG wiring and an indicator lamp that displays the state of the field input devices.

Two converter types are available. A red colored converter is used for 120 VAC input signals and presents a 2-3 VA load to the AC line. Signal conversion time is 7-17 milliseconds.

A blue colored converter operates with 10 to 55 VDC inputs, presenting a nominal load of 20 milliamperes independent of supply voltage. Signal conversion time is 2-3 milliseconds.

## OUTPUTS

Output devices, such as solenoids and motor starters, are wired to individual plug-in output converters. These units incorporate screw terminals for two number 14 AWG leads, one for supply and one for load. An indicator lamp monitors the state of the switched output voltage.

Two output converter types are available. A red colored converter with an inrush capability of 30 amperes for 30 milliseconds is used to drive 120 VAC output devices with current rating of 2 amperes. Signal conversion time is less than 1 msec turn-on and less than 9 msec turn-off.

A blue colored converter with an inrush capability of 8 amperes drives 10 to 55 VDC output devices with a continuous current drive of 2 amperes. Each output converter may switch an independently supplied voltage. Signal conversion time is less than 1 msec turn-on and less than 3 msec turn-off.

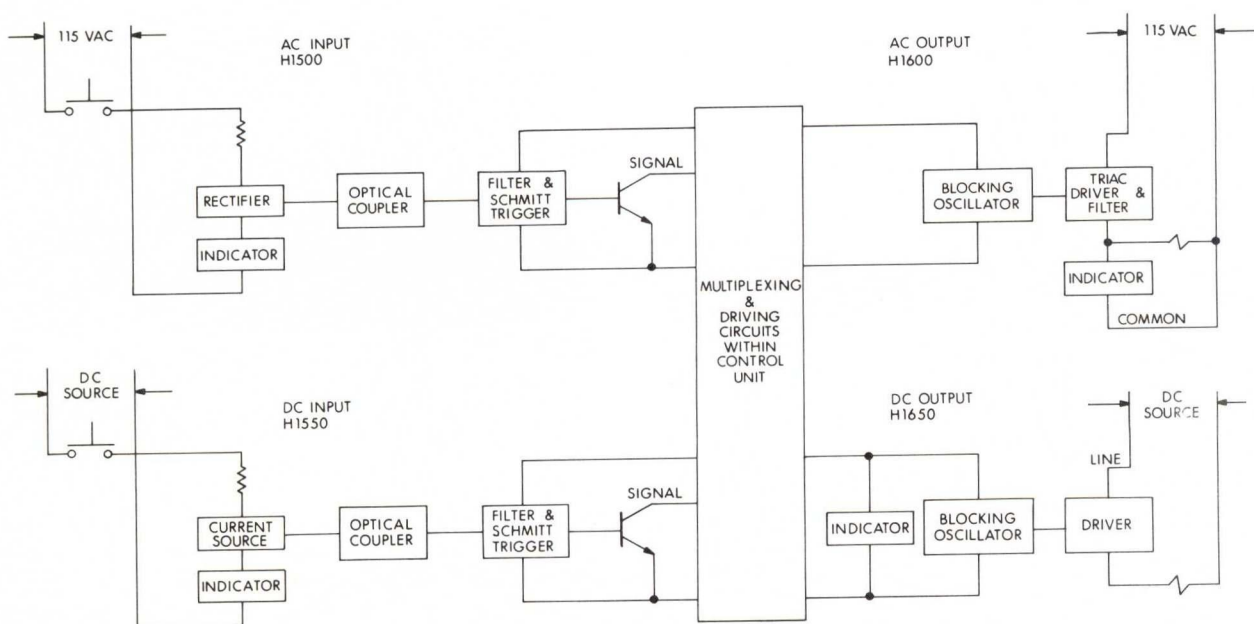

# THE CONTROL UNIT AND MEMORY

- NEMA-12 type cast aluminum housing for environmental protection and stable operating temperatures.
- Front panel status indicators to immediately signal system failures and facilitate troubleshooting.
- Printed circuit backplane to improve reliability and eliminate backplane wiring alternations.
- Low piece count requiring fewer circuit boards as spares.
- Side mount connectors for I/O and computer interfaces eliminate the need to open the housing during operation.
- Read/Write memory for simple on-the-spot re-programming.
- 2.5 millisecond scan time per 1K of programmed memory for quick system response.
- Non-formatted memory to use only as much memory as is required for each circuit.
- A portion of main memory, at no extra cost, provides timers, retentive memories, counters and shift registers.

A cast aluminum housing built to NEMA-12 specifications encloses the Industrial 14/30 and 14/35 control units. This ensures the necessary heat-transfer properties to keep the electronics within their operating temperature. Additionally, the shielding characteristics of the housing protect the electronics and the Read/Write core memory from radiated interference. The NEMA-12 type housing protects the control unit from the punishing contaminants of industrial atmospheres: metal chips, dust, dirt, coolants. Front panel indicators on the Industrial 14s confirm the general status of the controller. Two status lights (power on and system run) and two failure lights (address error and bus error) clearly indicate either the proper operation or signal the failure of a particular sub-system.

A printed circuit backplane in the 14s provides a parallel bus structure, thereby eliminating the danger of improper operation when a module is plugged into the "wrong" slot. The printed circuit approach also eliminates the need to ever alter the backplane wiring to accommodate future options. Furthermore, there are no interconnecting wires to break, short or vibrate lose, or protruding wire-wrap pins to catch metal filings or wire strands that may cause backplane shorts.

The control unit's low piece count (only four essential modules) enables quick isolation and replacement of any defective internal circuit board. This, too, means that it is not necessary to inventory a large number of circuit boards as spares.

Because there are side mount connectors for the I/O, programming terminal, and computer interfaces, there is no need to ever open the housing during normal operation. And the system is provided with a single power supply which is adequate for the present system and for any future expansion.

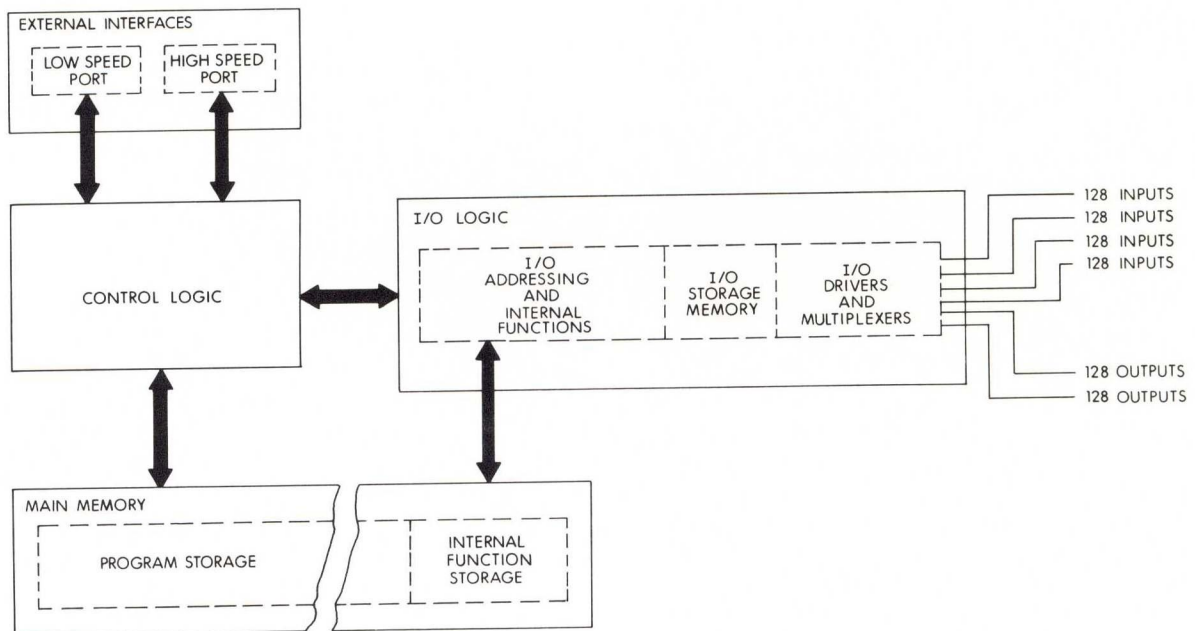

**INDUSTRIAL 14 CONTROL UNIT FUNCTION**



## THE CONTROL LOGIC

The high-speed circuitry contained in the 14/30 and 14/35 control units is comprised of control logic, I/O addressing logic and main memory. The control logic is a single plug-in module responsible for the overall coordination of the I/O and memory functions. It receives instructions from the control program as stored in memory. Acting upon these programmed instructions, it samples the proper I/O points (internal and external) and sets each output on or off based upon the current I/O conditions.

The control logic also interacts with the external interfaces to supply information to, or receive data from, the VT14 programming terminal or an external computer.

## THE I/O LOGIC

The I/O logic consists of three plug-in modules that supply the control logic with the on/off condition of inputs, outputs and internal functions; receive signals from the control logic to set outputs on or off; or operate internal functions (timers, counters, etc.).

These functions include:

1. Reading all current input states into an I/O storage memory used for sampling by the control program.
2. Recording in the I/O storage memory, the output states as set by the control logic in accordance with the instructions stored in memory.
3. Controlling the internal functions, including incrementing locations in main memory based on a clock input for timers, or based on an increment signal for counters. Supplying the current state of internal functions when sampled by the control program.
4. Driving the external output converters on or off as specified in the I/O state memory.

## THE MAIN MEMORY

The main memory provides storage for the control program, supplying the stored instructions to the control logic. In addition, a small section (256 words) is used to store the preset and current values for internal functions. Thus timers, counters, retentive memories and shift registers are provided in the 14s *at no extra cost*.

The 14s use a ferrite core Read/Write memory offering quick in-plant program changes. However, special attention has been given to its reliable operation in industrial applications: the core is of a design that has good temperature stability due to a relatively high content of lithium; secondly, it is operated at a significantly lower speed than a normal computer memory; thirdly, the memory is well protected and shielded by the sealed enclosure of the 14's control unit.

The 14/30 contains 4,000 (4K) words of Read/Write memory that can be extended with a second block of 4K words. The 14/35 contains 8K words of memory and cannot be extended. The memory can be easily reprogrammed (completely or in small portions) whenever needs require. Output circuits are scanned at an average rate of 2.5 milliseconds per 1K of programmed memory, guaranteeing recognition of and response to very fast input signals.

The 14's non-formatted memory provides that each control circuit uses only the memory that is required. Output circuits are "solved" as they are entered by the user and not in any pre-established numeric order as in some other programmable controllers that use an "executive" system.

As can be seen, the 14's design makes maximum use of the Read/Write memory for internal functions as well as for the efficient storage of the control program.

# INTERNAL FUNCTIONS

## I/O AND INTERNAL FUNCTION GROUPS

The 14's inputs, outputs and internal functions are organized in the following fashion:

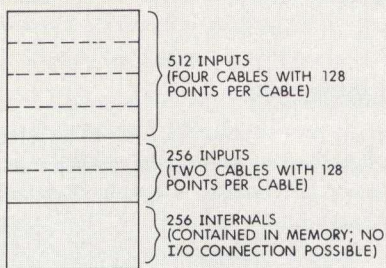

The 256 internal functions are used in a mix that best suits the application. Retentive memories and shift register bits require a single internal function; timers and counters require two internal functions; and the four Up/Down counters each use four internal functions.

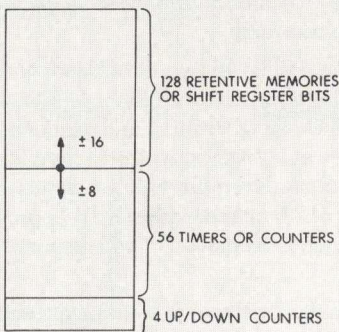

The normal grouping of internal functions is as shown above. However, a simple switch setting adjusts this mix of functions to give more (or fewer) retentive memories in groups of 16, while correspondingly decreasing (increasing) the number of timers in groups of 8.

- Full complement of I/O points always available, regardless of the number of timers, counters or retentive memories.
- No additional hardware required to implement timers, counters, shift registers, retentive memories or up/down counters.
- An adjustable mix of function types to meet the needs of any application.
- Internal functions retain their value through a power loss or can be programmed to reset, to meet the needs of any application.
- Since the logic for all outputs is wired into the system, any unused output can be used as a storage function.

Typical control systems require auxiliary status signals in addition to the on and off states of machine inputs and outputs. For example, timers are necessary to provide dwell at the end of a motion or to sequence a batch process. Counters are used to limit the number of pallets on a conveyor or to count the number of parts made each hour. While these functions require additional hardware in most control systems these and other features are standard in the Industrial 14s. They are achieved internally by reserving a small section of main memory in the controller. Thus 256 external outputs are always available because auxiliary functions do not affect the capacity of the 14 for "real" outputs.

The user has the capacity to adjust the mix of internal functions. You can have 128 retentive memories or shift register bits and 60 timers or counters. Or you can adjust the mix of timers and counters with retentive memories and shift registers to suit a specific application.

Furthermore, an added benefit of the 14's external I/O structure is that since all the output electronics (except the actual output converters) are packaged into the control unit, any unused external output can be used as a storage output without any additional hardware or cost.

*Retentive memories* are used like a latching relay to retain a logic state in the event of a power failure. Furthermore, a group of retentive memories may be used to form a shift register that will not lose its contents on a power failure. If required, individual retentive memories can, through programming, be made non-retentive and act like a simple storage output.

*Shift registers* are formed from a group of retentive memories or unused external outputs. Using an external or internal I/O number, a fully programmable circuit controls the shifting operation. Each bit of the shift register has its own I/O number, so that any or all elements in the shift register may be parallel loaded and/or parallel read.

*Digital timers* are provided with an instantaneous and timed out contact so that a timer can be triggered by a pulse and sealed in the timing state. Delays of up to 99.9 seconds in 0.1 second increments, or 999 seconds in 1 second intervals can be directly implemented. If required, longer intervals are possible by cascading the timer with a counter.

*Counters* have contacts that sense when the current value is greater than or equal to the preset value. Separate circuits are provided to increment the counter and to clear it. Counts of up to 999 events are achieved by a single counter circuit. Still larger counts are possible by cascading two or more counters.

*Up/Down Counters* enable the 14s to directly check for an allowable limit of parts (in a conveyor, for example). Four special counters are provided which have a programmable decrement in addition to the increment and clear circuits of a normal counter.

### Industrial 14/30 and 14/35 Internal Functions

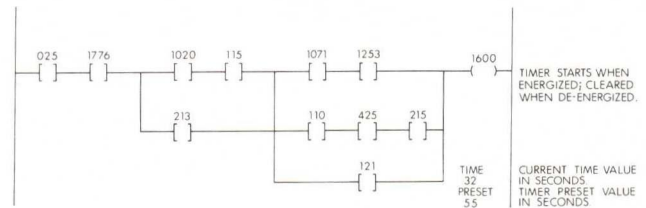

(a) Typical Timer Circuit

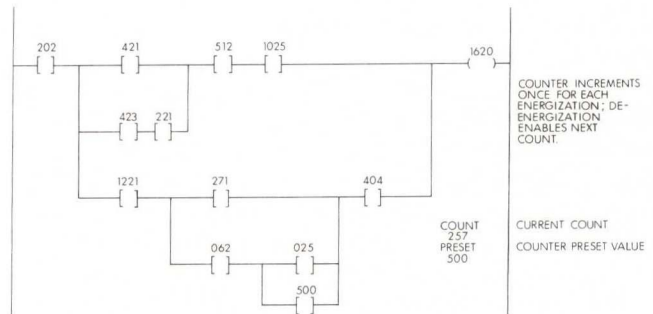

(b) Typical Counter Circuit

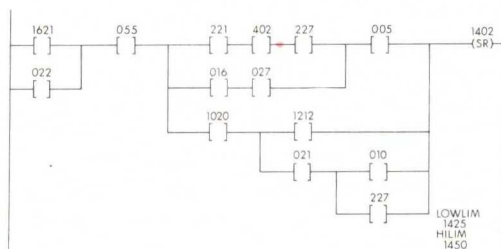

(c) Typical Shift Register Circuit

# THE VT14 PROGRAMMING TERMINAL

- CRT displays each element as it is entered, visually verifying each entry.
- Position-by-position editing capability, prior to or after storage in the 14's memory allowing quick and easy programming changes.
- Circuit monitoring with all contacts intensified that will pass current for easy monitoring of system operation.
- Flexible circuit format allowing branches to be used anywhere within the 10 x 8 element grid allowing virtually any circuit to be entered without reformatting.
- The full allowable circuit can be used for all internal and external functions.
- Disable and force I/O capability for use during system start-up and check-out.
- Optional Teletype connection for hard copy and program storage.

The VT14 Programming Terminal is used to directly program a controller's memory with relay ladder diagram symbols. It contains a cathode ray tube (CRT) display interfaced to functional push buttons for normally open and closed contacts, branch circuits and the output coil. In addition, function keys and data switches are used to program shift registers, timers, and counters; to display circuits already stored in the 14's memory; and to make changes within a programmed circuit.

A flexible circuit format for the VT14 allows up to 8 parallel paths with each path containing up to 10 contact and branch elements in series. Branches can be used anywhere within the 10 x 8 element grid with virtually no restrictions. The full allowable circuit can be used for all internal functions including timers, counters (for both the clear and increment circuits), retentive memories and shift registers (for both the shift circuit and for any parallel load circuits).

As each element is entered, each contact, branch, and coil is added to the visually displayed ladder diagram. A position indicator (cursor) always shows where, within the circuit, the next entered element will be drawn. Position-by-position editing capability enables any circuit to be corrected without having to totally re-enter it. Any position within the 10 x 8 circuit grid, therefore, may be changed without affecting the rest of the circuit. This editing capability may be performed at any time—prior to its storage within the controller's memory or after it has been stored.

Once programmed, any internal or external output circuit can be displayed in monitor mode, with all contacts that will "pass current" intensified. In addition, if the output is energized the coil is intensified. This feature enables the user to view a circuit to determine what condition is not being met, thereby keeping the output off. In addition to circuit conditions, an internal timer or counter circuit can be viewed to determine its current and preset values.

The guidelines that apply to circuits entered into the VT14 are:

1. The VT14 allows a circuit of up to 8 lines with a maximum of 10 elements in each line. An element is either a contact, a branch point or a space.
2. Diagrams are entered left to right, line by line. Each line must be completed before the next line is started. The first line includes the output symbol (-O-) as the eleventh element.
3. Branches may occur anywhere within the circuit. A down branch (↓) symbol opens the branch and an up branch symbol (↑) closes the branch. These branch symbols are included in the number of elements allowed on each line.

The force I/O feature of the VT14 terminal permits any external output driver to be disconnected from its control circuit and forced into either the ON or OFF state. The driver will remain in the forced state, regardless of conditions within its control circuit, until it is re-enabled. Any input signal, as well, can be disconnected from its actual input and forced into either the ON or OFF state. The logical input as "seen" by the control unit will remain in the forced state, regardless of the external input circuit, until it is re-enabled.

An optional Teletype connection provides a hard-copy listing of the complete control program in ladder diagram format. This connection can also provide a paper tape copy of the control program which can be read into other controllers for the same application or be used to reload the controller if its memory is accidentally cleared.

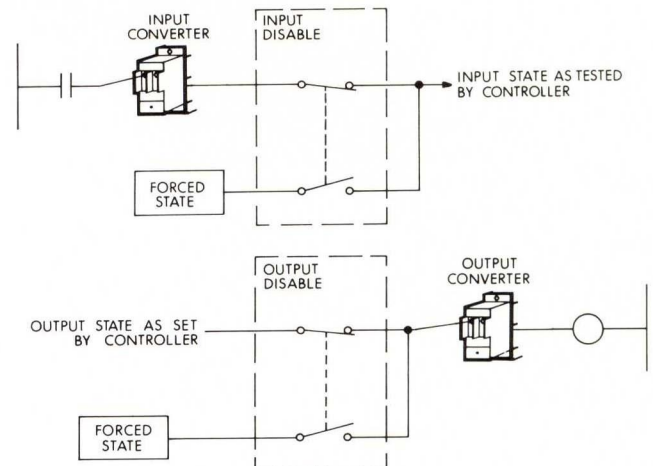

**I/O Disable and Forcing From the VT14**



### COMPUTER COMPATIBILITY

- Two ports for connection to external devices that can be used simultaneously.
- Low-speed port for connection to either a programming terminal or a maintenance panel.
- High-speed port for communication with a computer.
- PDP-8 based software for implementing or diagnosing the 14/30 and 14/35 controllers.

### CONTROLLER-COMPUTER INTERFACING

The Industrial 14 system design provides optional computer monitoring capability at any time. When required, the computer can monitor any control operation or gather data and convert it into printed records. The most effective computers for Industrial 14 monitoring are the PDP-8 or PDP-11 family computers.

The 14s have two ports for connection to external devices: the *low-speed port* is a 20mA or EIA standard 9600 baud serial communication channel that normally connects the 14 to its programming terminal or to a maintenance panel. The *high-speed port* is for fast, frequent communication with a computer using either a parallel DA14 interface to a nearby PDP-8, or a DC14 interface operating at 211.2 K baud to a remote PDP-8 or PDP-11 computer. Both ports can be used simultaneously without any danger of interaction.

### COMPUTER-BASED PROGRAMMING

While the VT14 is an extremely attractive and powerful approach to implementing Industrial 14/30 and 14/35 systems, Digital also offers techniques for programming these systems based upon a PDP-8 computer. This software includes a program to accept Boolean equations written in symbolic terms and generate the corresponding control program for the 14/30 or 14/35. This control program can be in a form compatible with the VT14 such that a program generated on a PDP-8 may be modified later using the programming terminal.

A second program allows a PDP-8 to assist in the check-out and start-up phases of a 14 controlled system. It allows modification of the 14's memory, sampling of the 14's inputs and outputs, adjustment of timer and counter values and forcing of inputs and output states.

PDP-8 based software is also available to diagnose 14/30 and 14/35 controller malfunctions.

# INSTALLATION AND MOUNTING

The Industrial 14 is, physically, a simple structure. Its compact dimensions enable it to be mounted in a cabinet size that is in direct proportion to the size of the control task; i.e., a small cabinet for a small system and a larger cabinet for larger systems. The NEMA-12 housing of the control unit environmentally protects it from electrical noise and industrial contaminants. The table below summarizes the specifications for the Industrial 14/30 and 14/35, while the accompanying drawings show sample cabinet layout.

Control Unit	22" high x 17.25" wide x 10.75" deep
Power Supply	8" high x 17.25" wide x 5.25" deep
I/O Mounting Panel	4.0" high x 17.5" wide x 3.0" deep (including height of overlapping connectors)
I/O Group (8 mounting panels)	33.3" high x 17.5" wide x 3.0" deep (includes clearance for cable)
Control Unit	32° to 150° F (0° to 65° C)
Outside Cabinet	32° to 130° F (0° to 55° C)
Storage Temperature	-4° to 185° F (-20° to 85° C)
Relative Humidity	5 to 95° Non-condensing
Line Voltage	95 to 130 VAC, Single Phase OR 190 to 260 VAC, Single Phase
Line Frequency	47 to 63 Hz

## MAINTENANCE

The key problem in any troubleshooting effort is locating the problem area. By making the Industrial 14s easy to understand and by providing strategically placed status indicator lamps, most troubles are easily and quickly identified, thereby significantly reducing downtime.

As the illustration indicates, signal lights are used to trace an input action through the controller to the associated output. Thus, if an input signal is not present at the input converter, the light will not be on, and the fault is immediately isolated to either the input device or the associated wiring. Similarly, if an output light is on and yet the proper action has not occurred, the fault is isolated to either the output device or its wiring. Finally, if the proper input lights are on and yet the output light is off, the failure must reside in the controller or its I/O converters.

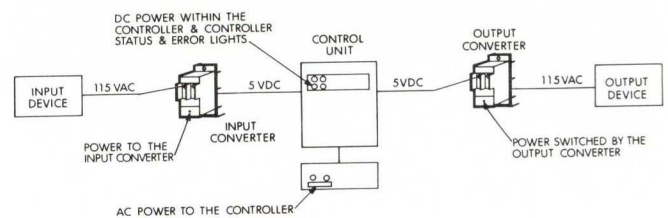

## TYPICAL CONFIGURATIONS

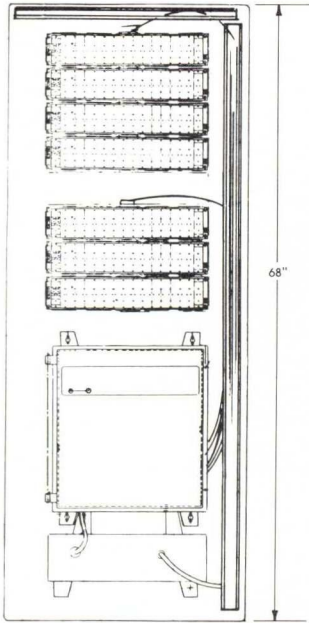

64 Inputs  
48 Outputs

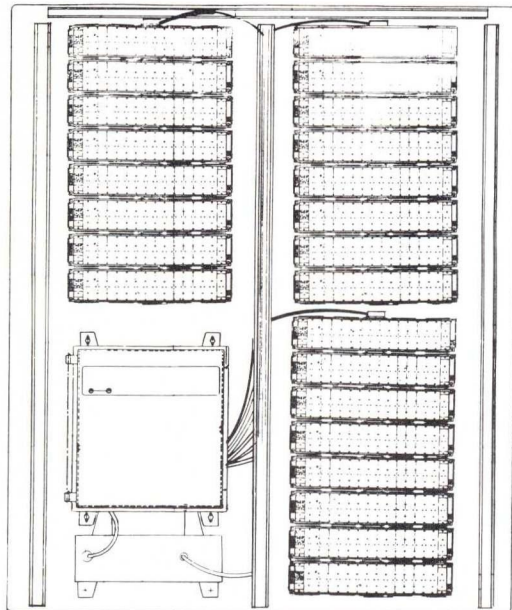

256 Inputs  
128 Outputs

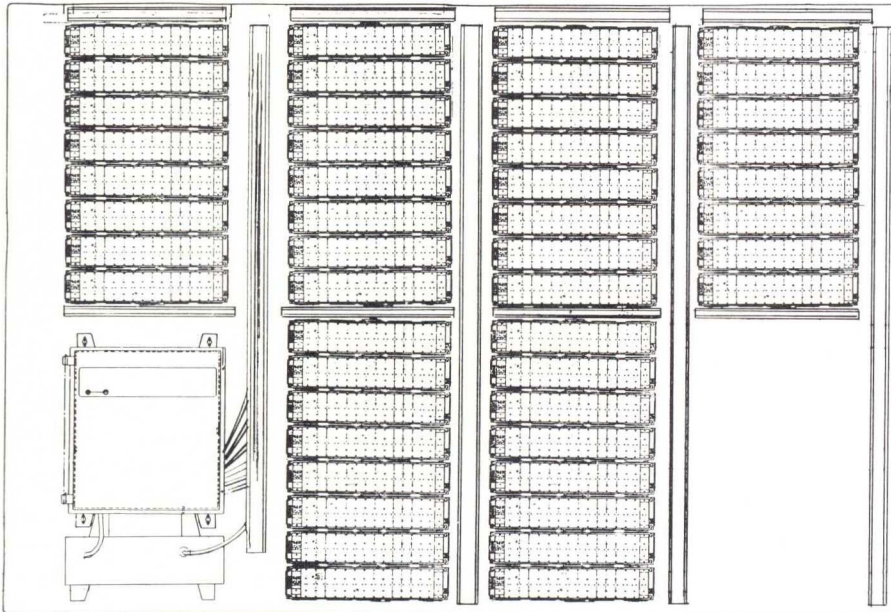

512 Inputs  
256 Outputs

# INDUSTRIAL 14 APPLICATION AREAS

Programmable control is being used in an ever-widening, more demanding variety of application areas. Industrial 14s serve as the control system in material handling, machining and metalworking, measuring and gaging, automated assembly and chemical processing. Their responsibilities within these industries are growing because of their proven success. In fact, many of these complex operations could not have been attempted if conventional control had been used.

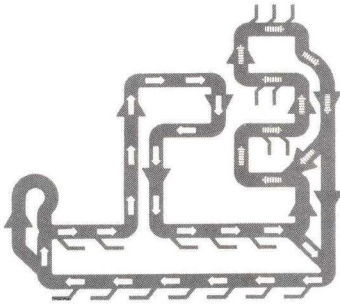

## Material Handling

Programmable control of conveyors and lifts in systems that handle virtually thousands of pallet loads per shift has proven to be highly efficient and accurate. The 14s handle all types of palletizers and can alter pattern configurations through re-programming. Programmably controlled stacker cranes have helped to make the high-rise warehouse possible. And when all of these efficiently run systems are combined into the automated warehouse, programmable control is largely responsible.

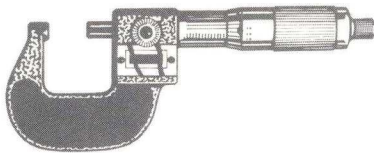

## Measuring and Gaging

Sophisticated machinery, the demand for high-precision parts, and regulations on product quality have all called for more accurate methods of measurement by industry. Whether or not they are working with a computer, Industrial 14s are controlling part positioning, probe positioning, maintenance of good/bad status, ejection of bad parts, passing good parts, cycling the test sequence, providing safety interlocking and power shutdown /start-up circuitry and taking directions from operators via push buttons and selector switches.

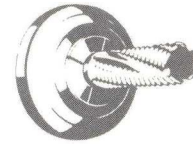

## Machining and Metalworking

A vital need for programmable control has been and still is acute among automobile manufacturers and metalworking operations where standardization is particularly important for ease of maintenance. The 14 is controlling such machinery as the dial index machine and grinder as well as the complex operations of the multi-station transfer machine. The 14s are controlling the operations of integrated manufacturing systems where there are requirements for variable machining cycles, multiple parts, automatic loading/unloading and in-line gaging.

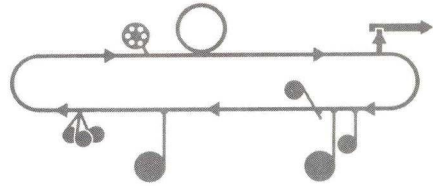

## Automated Assembly

In high-speed operations where the life span of controlling equipment is so important, the 14s are continually displaying their reliability. In the area of product quality, the 14s are boosting economy by maintaining tight control on reject parts. And when product changes must be implemented quickly and easily, the 14 responds by simple re-programming. All of these highly significant improvements are working within the dial assembly machine, the in-line synchronous assembly machine and the increasingly prevalent integrated assembly systems.

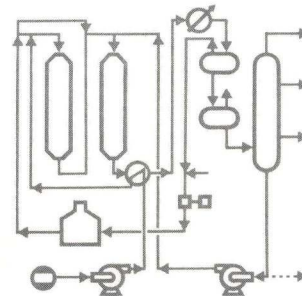

## Chemical Processing

Programmable control has taken man out of hazardous working conditions by using a 14 instead. Widespread and large chemical processing equipment can be controlled by the compact and remotable 14, often under the direction of a centrally located computer. The 14 is not subject to "recipe" inconsistencies caused by a change of operators. In both batch and continuous processing operations, the 14s are proving to be reliable, capable and consistent.

