

DECrouter 200

Hardware Installation/Owner's Guide

Order No. EK-DR200-IN-001

November 1986

This guide explains how to install the DECrouter 200 and how to verify its operation. The guide also describes the DECrouter 200 controls and indicators. This document is intended for the hardware installer and the server manager.

Supersession/Update Information: **This is a new manual.**

digital

The information in this document is subject to change without notice and should not be construed as a commitment by Digital Equipment Corporation. Digital Equipment Corporation assumes no responsibility for any errors that may appear in this document.

No responsibility is assumed for the use or reliability of software on equipment that is not supplied by Digital Equipment Corporation or its affiliated companies.

Copyright © 1988 by Digital Equipment Corporation
All Rights Reserved.
Printed in U.S.A.

The postage-prepaid Reader's Comments form on the last page of this document requests the user's critical evaluation to assist us in preparing future documentation.

The following are trademarks of Digital Equipment Corporation:

DEC	Micro/RSX	TOPS-10
DECconnect	MicroVAX	TOPS-20
DECmailer	MicroVMS	ULTRIX-32
DECmate	PDP	ULTRIX-32m
DECnet	P/OS	UNIBUS
DECserver	Professional	VAX
DECUS	Rainbow	VAXcluster
DECwriter	RSTS	VAXmste
DIBOL	RSX	VAX/VMS
	RSX-11M-PLUS	VMS
MASSBUS	RT	VT
MicroPDP-11	ThinWire	Work Processor

Bell is a trademark of Bell Telephone Companies.

IBM is a registered trademark of International Business Machines Corporation.

PC/XT and Personal Computer AT are trademarks of International Business Machines Corporation.

Teflon is a trademark of E.I. du Pont de Nemours & Company, Inc.

This manual was produced by Networks and Communications Publications.

Contents

Preface

1 Introduction to the DECrouter 200

1.1	DECrouter 200	1-1
1.2	Functions of the DECrouter 200	1-2
1.3	Hardware Installation Overview	1-3
1.3.1	Connecting the DECrouter 200 to the Ethernet Network	1-3
1.3.2	Connecting Port Devices to the DECrouter 200	1-6
1.4	DECrouter 200 Software	1-8

2 Contents of Shipment

2.1	Number of Boxes	2-1
2.2	Contents of the DECrouter 200 Box	2-1
2.3	Contents of the Accessories Box(es)	2-2

3 Site Preparation

3.1	Arranging for Software Installation	3-1
3.2	Placing the DECrouter 200	3-2
3.2.1	Offices	3-2
3.2.2	Rack Mount	3-2
3.2.3	Satellite Equipment Rooms (SER)	3-2
3.3	Cable Configuration Rules	3-3
3.4	Preinstallation Checks	3-5

4 DECrouter 200 Installation

4.1	Introduction	4-1
4.2	Verifying the Voltage Select Switch Setting	4-1
4.3	Connecting the Transceiver Cable	4-3

4.4	Before Connecting Power	4-6
4.5	Connecting Power	4-7
4.6	Verifying Operation	4-8
4.7	Connecting Device Cables to the DECrouter 200	4-9
4.8	Verifying System Installation.....	4-11

5 What to Do if You Have Problems

5.1	Introduction	5-1
5.2	Diagnosing Router Problems	5-1
5.3	D1 LED Off	5-3
5.4	D2 LED Off	5-3
5.5	D2 LED Blinking	5-4
5.5.1	Error Messages 922 and 923	5-4
5.5.2	Error Message 932	5-4
5.5.3	Error Messages 941, 942, and 950	5-5
5.5.4	No Messages on Console Terminal	5-6
5.6	D3 LED Blinking	5-7
5.6.1	Down-Line Load Starts, Then Fails	5-7
5.6.2	Down-Line Load Does Not Start.....	5-8

A Controls and Indicators

A.1	Controls	A-1
A.1.1	Switch (S1)	A-1
A.1.2	Voltage Select Switch	A-1
A.1.3	Circuit Breaker	A-2
A.2	Status Indicator LEDs	A-2

B Port Devices Supported by DECrouter 200

C Ordering Information

C.1	DECrouter 200 Hardware Units	C-1
C.2	DECrouter 200 Country Kits	C-1
C.3	DECrouter 200 Accessories	C-2
C.4	Transceiver Cables	C-2
C.5	Device Cables	C-3

D Cable Structure

D.1	DECrouter 200 Device Connectors (J1 through J8).....	D-1
D.2	Serial Line Circuit Standards	D-2
D.3	DECrouter 200 Device Cables.....	D-3

D.3.1	BC17D Shielded Null Modem Cable.....	D-3
D.3.2	BC22D Shielded Null Modem Cable (Data Leads Only).....	D-4
D.3.3	BC22E or BC22F Shielded Straight-Through Cable (Full-Modem) ..	D-5
D.3.4	DECrouter 200 Port Loopback Connector	D-6

E **DECrouter 200 Specifications**

E.1	Power	E-1
E.2	Environment	E-1
E.2.1	Temperature	E-1
E.2.2	Altitude	E-1
E.2.3	Relative Humidity	E-2
E.2.4	Physical Size of the DECrouter 200	E-2
E.2.5	Space Requirements	E-2

F **Service Options**

F.1	Hardware Services	F-1
F.1.1	Digital On-Site Service	F-1
F.1.2	DECmailer	F-1
F.2	Installation Service	F-1
F.3	Software Services	F-1
F.3.1	Software Product Service Agreements	F-1
F.3.2	Training	F-1

G **Connecting to Etherjack**

Figures

1-1	DECrouter 200	1-1
1-2	Standard Ethernet Coaxial Cable Connection	1-4
1-3	ThinWire Ethernet Coaxial Cable Connection	1-5
1-4	DECrouter 200 Port Device Connections	1-6
2-1	DECrouter 200 Shipping Box Contents	2-1
4-1	DECrouter 200 Hardware Verification	4-8
A-1	Controls and Indicators	A-1
D-1	Pin Numbers — DECrouter 200 Device Connectors (J1 through J8)	D-1
D-2	Pin Assignments — BC17D Shielded Null Modem Cable	D-3
D-3	Pin Assignments — BC22D Shielded Null Modem Cable	D-4
D-4	Pin Assignments — BC22E or BC22F Shielded Straight-Through Cable	D-5
D-5	Wiring Diagram — DECrouter 200 Port Loopback Connector	D-6

Tables

1-1 Device Cables 1-7
3-1 Maximum Cable Lengths 3-3
5-1 Status LEDs/Indications 5-2
A-1 Status LEDs A-2
D-1 Circuit Standards D-2
E-1 DECrouter 200 Power Ratings E-1

Preface

This guide explains how to install the DECrouter 200 and how to verify its operation. The guide also tells how to order Digital services and products that support the DECrouter 200.

The only tool required for installation is a small flat-blade screwdriver.

You should keep this guide with your DECrouter 200 unit.

Intended Audience

- **Router Manager**
- **Hardware Installer**

How to Use This Guide

Before you install the DECrouter 200, it is recommended that you read Chapters 1, 2, and 3. These chapters provide a functional overview of the DECrouter 200 and the installation process, including important site preparation information. Chapter 4 provides the procedures to install and verify the DECrouter 200. If problems occur during verification, refer to the troubleshooting procedures in Chapter 5. The appendixes offer additional information that may be useful during installation.

Structure of This Guide

This guide contains five chapters and seven appendixes, as follows:

- Chapter 1** Introduces the DECrouter 200 from a functional point of view and describes the installation process and the software requirements.
- Chapter 2** Describes the contents of the DECrouter 200 shipment and provides instructions for getting help if the equipment is damaged.
- Chapter 3** Discusses important site preparation information that must be considered before the DECrouter 200 installation begins.
- Chapter 4** Provides an illustrated step-by-step procedure for installing and verifying the operation of the DECrouter 200.
- Chapter 5** Provides help in isolating problems that can occur during the installation of the DECrouter 200 and provides procedures to correct them.
- Appendix A** Describes the controls and indicators on the DECrouter 200.
- Appendix B** Lists devices supported by the DECrouter 200.
- Appendix C** Lists the order codes for the DECrouter 200 and related hardware products.
- Appendix D** Provides device cable wiring diagrams for users who want to assemble and use their own cables.
- Appendix E** Provides DECrouter 200 specifications.
- Appendix F** Describes the Digital hardware and software service options that are available for the DECrouter 200.
- Appendix G** Describes how to connect the DECrouter 200 transceiver cable to another transceiver cable mounted in an Etherjack junction box.

Other DECrouter 200 Documents

Ordering information for the following documents is in the release notes that accompany the DECrouter 200 software:

- *DECrouter 200 VMS/MicroVMS Installation Guide*
Describes the installation of router software and the configuration of DECrouter 200s on VMS/MicroVMS load hosts.
- *DECrouter 200 ULTRIX-32/32m Installation Guide*
Describes the installation of router software and the configuration of DECrouter 200s on ULTRIX-32/32m load hosts.

- ***Routing and Networking Overview***
Describes the basic routing terminology and concepts, and provides guidelines for achieving optimal routing performance when configuring networks.
- ***DECrouter 200 Management Guide***
Describes how to set up, manage, monitor, and troubleshoot the DECrouter 200.
- ***DECrouter 200 Identification Card***
Provides space to record unique identification data for each DECrouter 200.

Associated Document

- ***DECrouter 200 Technical Manual***
Describes the DECrouter 200 hardware and module logic and the Self-Test and Initialize programs.

1

Introduction to the DECrouter 200

1.1 DECrouter 200

The DECrouter 200 (model DSRVC-Ax*) is a high-performance, low-cost asynchronous router (see Figure 1-1) for use on Ethernet or IEEE 802.3 local area networks.

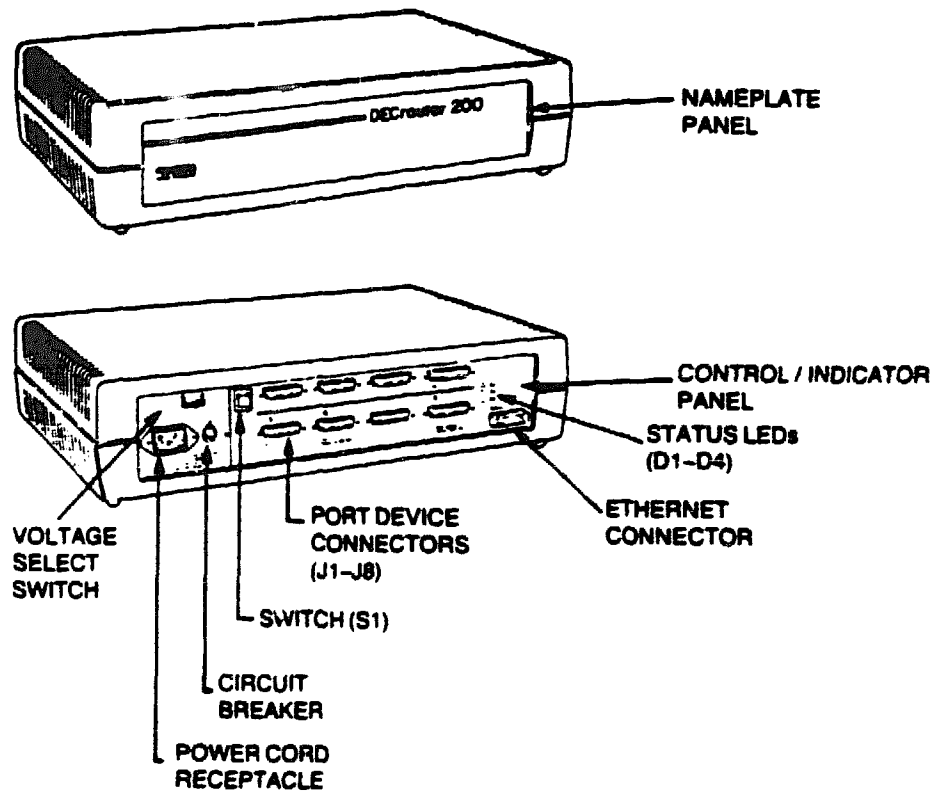

LKG-0524

Figure 1-1: DECrouter 200

NOTE

For a description of the DECrouter 200 controls and indicators, see Appendix A in this manual.

*The letter "A" or "B" replaces the "x" in the model designation to represent the following input voltage requirements:

Model	Input Voltages
DSRVC-AA	100---120 Vac
DSRVC-AB	220---240 Vac

1.2 Functions of the DECrouter 200

The DECrouter 200 allows any combination of eight attached nodes access to each other and to remote nodes on a DECnet network. These nodes are connected to the DECrouter 200 through full duplex, asynchronous devices that support V.28/RS-232-C (EIA232) standards and that use DECnet Phase III or Phase IV protocols with Digital Data Communications Message Protocol (DDCMP).

Devices that can be connected to the DECrouter 200 include modems, personal computers running DECnet, and larger computers running DECnet. For a list of devices supported by the DECrouter 200, see Appendix B.

DECnet nodes connected to the DECrouter 200 can also access other DECnet nodes that are connected to a larger DECnet network. The connections to these nodes is accomplished through routing nodes that are connected to the DECrouter 200, or that are connected to the same Ethernet segment as the DECrouter 200.

DECrouter 200 offers the following features:

- Allows connection to the Ethernet Local Area Network (LAN) and to a wider area DECnet network for DECnet nodes with an asynchronous, full duplex, DDCMP, V.28/RS-232-C (EIA232) connection.
- Manages DECnet routing (for example, message switching and best path analysis) that allows host DECnet nodes more time for application tasks.
- Reduces and simplifies cabling required for connecting nodes to the DECnet network.
- Supports dial-in and dial-out modems.
- Brings the features and functions of the full DECnet network to the nodes connected to the DECrouter 200.

You can install the DECrouter 200 in a variety of environments, including offices and computer rooms. The router can be placed on a desk or table, or can be mounted in a standard rack cabinet. Digital can also provide you with a wall/partition mounting bracket to mount the router directly onto an office wall or to suspend the router from partitioned office walls. This bracket must be ordered separately. See Appendix C for ordering information.

1.3 Hardware Installation Overview

Installing the DECrouter 200 hardware consists of first connecting the router hardware to the Ethernet network, then verifying the hardware installation. The device cables are connected to the router after the hardware installation is verified. The following sections provide an overview of the methods used to complete the connections.

NOTE

The DECrouter 200 is considered operational when the router hardware is successfully installed, and the system installation verification procedure is performed on one DECrouter 200 unit. The system comprises the installed DECrouter 200 hardware with the DECrouter 200 router software running on the hardware unit. See the appropriate DECrouter 200 Software Installation Guide for details about the system verification procedure.

1.3.1 Connecting the DECrouter 200 to the Ethernet Network

A transceiver cable connects the router to the Ethernet network (see Figures 1-2 and 1-3). The transceiver cable can be connected to any of the following:

- Another transceiver cable section. This cable can be secured in an Etherjack junction box.
- A DELNI Local Network Interconnect.
- A transceiver on a standard Ethernet coaxial cable for Digital baseband networks, or to a DECOM for Digital broadband networks.
- A ThinWire Ethernet Station Adapter (DESTA) on a ThinWire Ethernet coaxial cable (see Figure 1-3).
- A standard rack cabinet in a Satellite Equipment Room (SER) for DECconnect systems. See the *DECconnect Planning and Configuration Guide* for installing the DECrouter 200 in DECconnect systems.

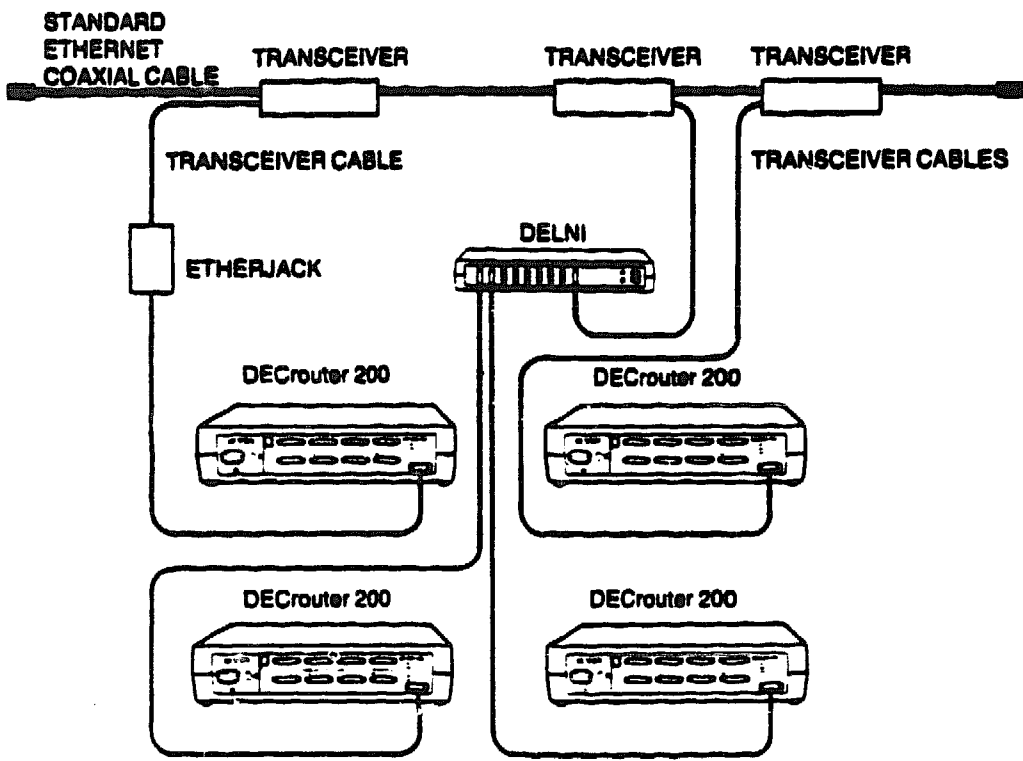

UKG-0536

Figure 1-2: Standard Ethernet Coaxial Cable Connection

NOTE

The DECrouter 200 is compatible with Digital baseband and broadband Ethernet products and with Ethernet and IEEE 802.3 specifications.

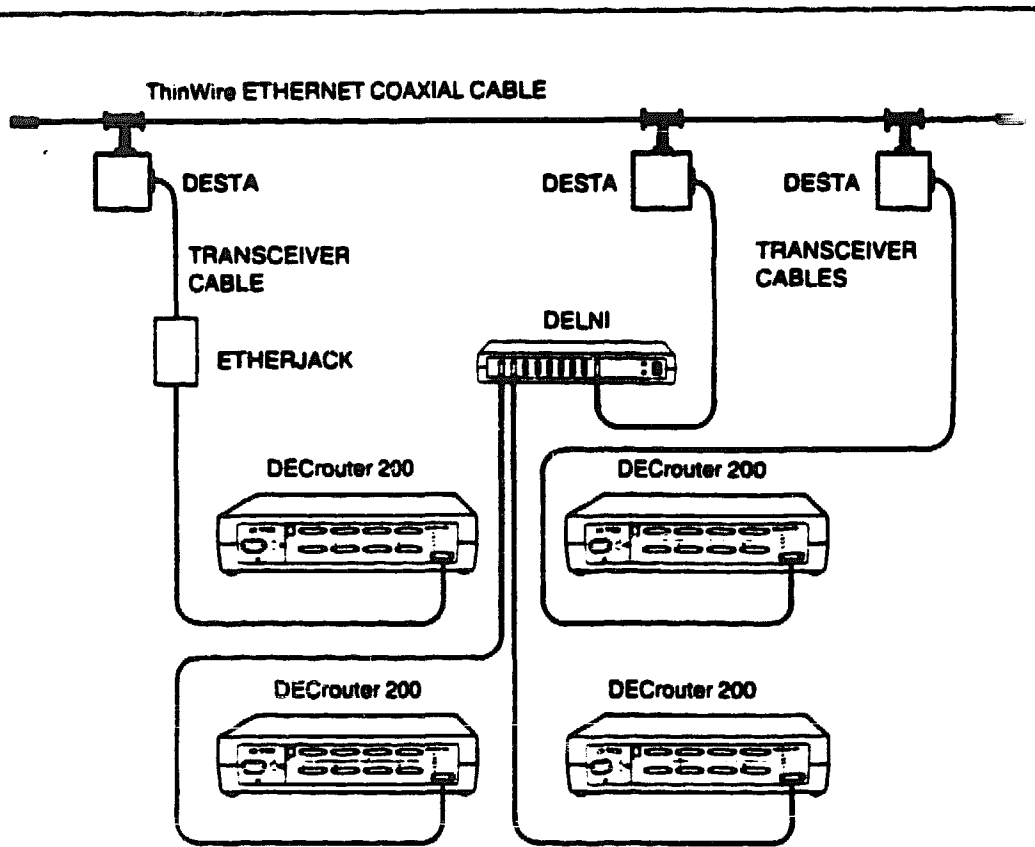

LKG-0525

Figure 1-3: ThinWire Ethernet Coaxial Cable Connection

The DELNI can stand alone or can be connected to the Ethernet coaxial cable. If you are connecting the DELNI to the Ethernet coaxial cable or to an Etherjack junction box, be sure to allow for an additional transceiver cable.

Make sure the transceiver connection is ready before the router installation begins. This means that the Etherjack, the DELNI, the DECOM, the DESTA, or the transceiver is installed, and the required transceiver cabling is in place, tested and tagged. See the appropriate product installation guide to install these products.

See Appendix C for a listing of all DECrouter 200 hardware options and order codes.

1.3.2 Connecting Port Devices to the DECrouter 200

You need one device cable for each port device you connect to the router (see Figure 1-4). Table 1-1 lists available cable types.

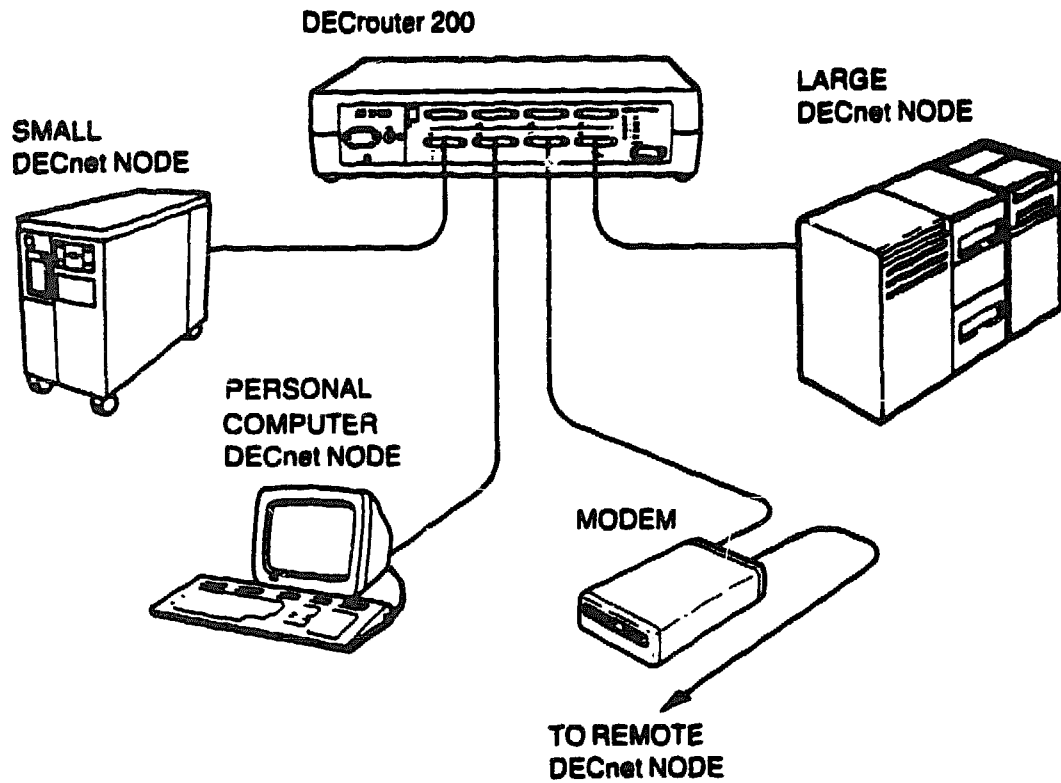

LKG-0527

Figure 1-4: DECrouter 200 Port Device Connections

Table 1-1: Device Cables

Use	Description	Cable Type
For connecting to modems (or equivalent devices)	Modem cable	BC22E or BC22F*
For directly connecting to devices that do not use modem control signals for operation (data-leads only)	Null modem cable (with data-leads only)	BC22D**
For directly connecting to devices that use modem control signals for operation	Null modem cable (with data- and modem control signal-leads)	BC17D

*The BC22F can be used in place of the BC22E cable but the extra control signal leads are not used. See Appendix D for more information.

**The BC17D cable can be used in place of the BC22D cable, but the modem control signals are not used. See Appendix D for more information.

The device cables can be ordered from Digital (see Appendix C for ordering information). If you are using your own cables, or want to assemble your own cables, refer to Appendix D for cable configuration information.

If you are using existing device cables, make sure the cables are accessible at the DECrouter 200 installation site before the installation begins.

1.4 DECrouter 200 Software

The basic software required for installing and operating the DECrouter 200 follows:

- DECrouter 200 distribution software — Installed on each DECrouter 200 load host
- DECnet Phase IV software — Installed on each DECrouter 200 load host (not required for ULTRIX systems)

You must install the distribution software on a load host that runs DECnet Phase IV software, and that is connected to the same Ethernet segment as the DECrouter 200. The distribution software includes a router image file that is down-line loaded to DECrouter 200s. The load host down-line loads the router image whenever required, and provides the router image to any number of routers. The router image, running on the DECrouter 200, constitutes the router software that enables the router to perform its functions.

Nodes connected to the DECrouter 200 must have DECnet Phase IV software installed and verified before the router can be operated.

All software must be installed and verified before you can operate the router.

For more information, see the DECrouter 200 Software Product Description that applies to the specific operating system.

2 **Contents of Shipment**

2.1 Number of Boxes

A single DECrouter 200 shipment consists of one or more boxes, depending on the optional equipment ordered. Be sure you received all your ordered equipment. Check each item for damage.

2.2 Contents of the DECrouter 200 Box

Check the box for the following items (see Figure 2-1):

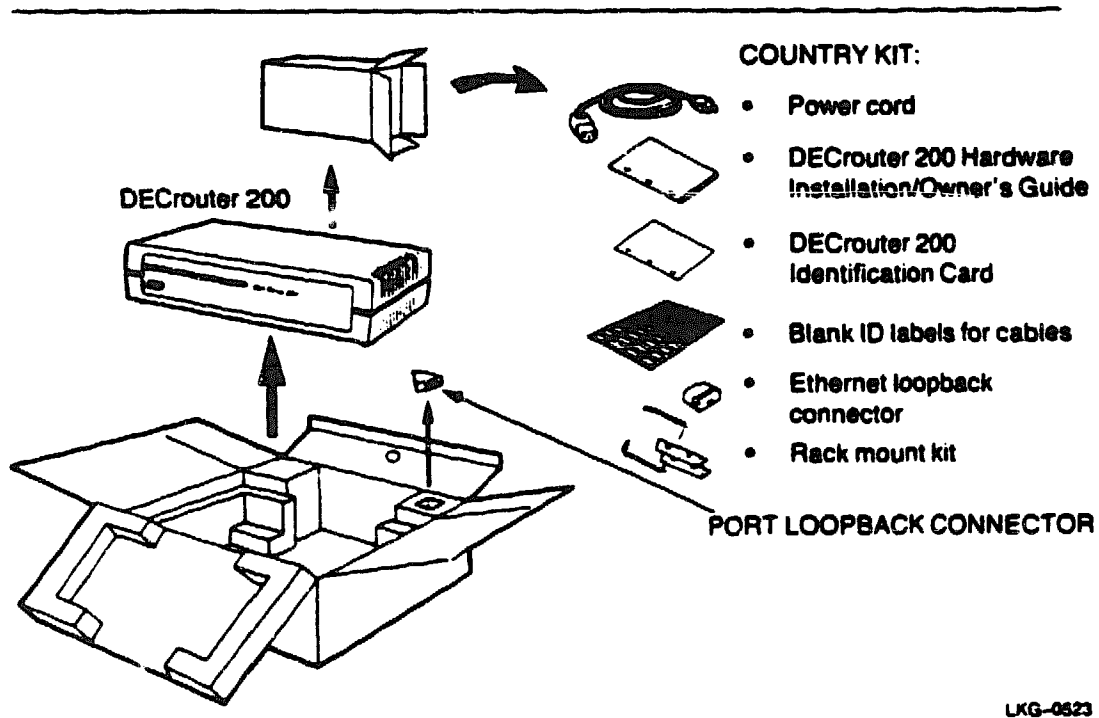

Figure 2-1: DECrouter 200 Shipping Box Contents

IN CASE OF DAMAGE:

- Stop unpacking.
- Contact your Digital sales representative and delivery agent.

IF PARTS ARE MISSING:

- Identify missing part(s).
- Contact your Digital sales representative.

NOTE

Save the box and packing material in case you need to return the unit.

2.3 Contents of the Accessories Box(es)

The number of boxes and their contents depends on the options you ordered. Open the accessories box(es) and check the contents against the ordered items that are listed in your bill of materials.

IN CASE OF DAMAGE:

- **Stop unpacking.**
- **Contact your Digital sales representative and delivery agent.**

IF PARTS ARE MISSING:

- **Identify missing part(s).**
- **Contact your Digital sales representative.**

NOTE

Save the box(es) and packing material in case you need to return items.

If you received an Etherjack junction box kit, install it now by following the installation instructions provided with the kit.

If you received a wall/partition mounting bracket kit, install it now by following the installation instructions provided with the kit.

3

Site Preparation

3.1 Arranging for Software Installation

- 1 Locate the router's serial number and the Ethernet address on the router's control/indicator panel.

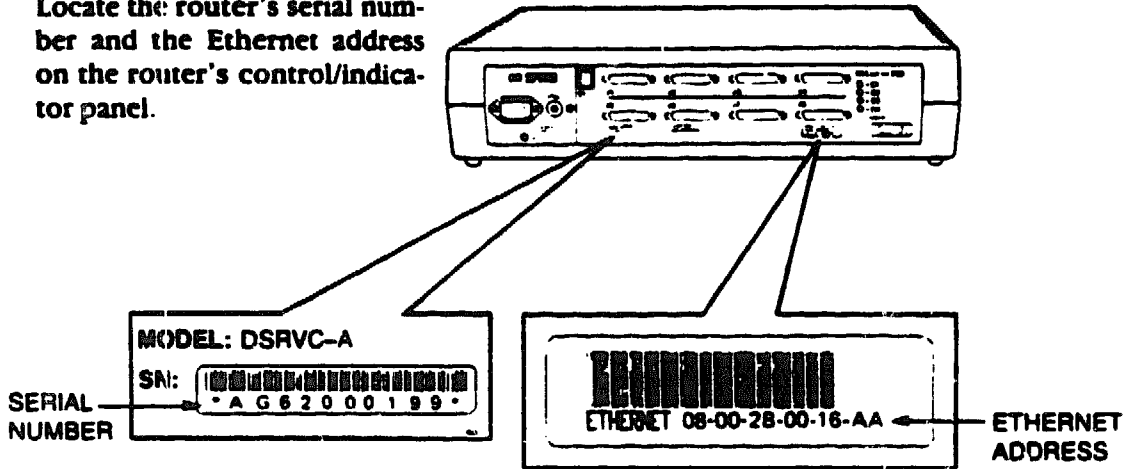

LKG-0522

- 2 Locate the DECrouter 200 Identification Card you received with the router. Copy the following information in the spaces provided on the identification card:

- a. The router's serial number
- b. The router's Ethernet address
- c. The location of the router (for example, office number, building, floor)
- d. Your name and the date of the installation

**DECrouter 200
Identification Card**

Hardware Installer

Please copy the serial number and the Ethernet address from the DECrouter 200 label on the router into this card. Also indicate your name, the date of the installation, and the location of the router in the spaces provided. Office number, building, floor. After copying the information on the card, the card and the router are returned to the manufacturer's factory.

Serial number: A 0 6 5 0 0 0 1 9 9

Ethernet address: 0 8 - 0 0 - 2 8 - 0 0 - 1 6 - A A

Location: Room 5-17

Your name: M. Lantz Date: 12-22-86

LKG-0529

- 3 Give the Identification Card and any software you received to the system/network manager (the person responsible for software installation). Ask to be notified when the distribution software is installed on the load host(s) and when the DECrouter 200 is configured in the load host database, if required by the load host(s).

Continue with the procedures through Section 4.4 of this manual.

3.2 Placing the DECrouter 200

The router can be placed in various locations, including offices and computer rooms, as long as the environmental requirements are met. See Appendix E, DECrouter 200 Specifications.

3.2.1 Offices

Allow 15 centimeters (6 inches) of airspace around the router air vents, and place the router on a desk or table that is at least 45 centimeters (18 inches) above the floor. This allows adequate ventilation for cooling fans and reduces exposure to excess dust from foot traffic.

NOTE

A wall/partition mounting bracket kit is also available from Digital that allows you to mount the router directly to a wall or to suspend it from partitioned office walls. Installation instructions are provided with the kit (see Appendix C for ordering information).

3.2.2 Rack Mount

The router can be rack mounted in a standard rack cabinet. To install, refer to the installation instructions provided with the rack mount kit.

3.2.3 Satellite Equipment Rooms (SER)

The SER is a component of Digital's DECconnect System. It provides a central location for communications devices (such as DECrouter 200s) that connect ThinWire Ethernet and twisted-pair cable to a standard Ethernet network. The SER can also be configured as the center of a stand-alone network, and provide a base from which to expand as network requirements increase. If you are installing the DECrouter 200 in such an environment, or as part of a DECconnect System installation, refer to the *DECconnect System Installation and Verification Guide*.

3.3 Cable Configuration Rules

Ensure that the transceiver cables, the device cables, and the router power cable do not exceed the maximum lengths described in Table 3-1 and in the configuration rules below.

Table 3-1: Maximum Cable Lengths

From	To	Maximum Cable Length	Cable Type
Transceiver	Router	50 m (164 ft) See rules 1 and 2	BNE3x-xx* Transceiver Cable
Transceiver	Router	12.5 m (41 ft) See rules 1 and 2	BNE4x-xx* Office Transceiver Cable
Device	Router	See rule 3	Depends on specific device (see Appendix D)
Wall outlet	Router	1.8 m (6 ft)	Router Power Cable (included in DSRVC-xx country kit)

Basic configuration rules:

- 1 Maximum length for the transceiver cable cannot exceed 50 meters (164 feet). This maximum length can be reduced due to the internal cabling equivalency of a device (such as a DELNI) that is connected between the router and the transceiver, or due to the use of office transceiver cable. For example:
 - Cabling equivalency is a measure of the internal timing delay of a device, expressed in meters of transceiver cable. This cabling equivalency must be subtracted from the 50-meter maximum. For example, if a device has a 5-meter cabling equivalency, then its maximum allowable transceiver cable length is (50 m - 5 m) or 45 meters.
 - Office transceiver cable (BNE4x-xx), due to its smaller diameter, has a signal loss that is four times that of the (BNE3x-xx) transceiver cable. Therefore, if office transceiver cable is used, the maximum transceiver cable distance must be divided by 4. This means the maximum office transceiver cable length allowed is 12.5 meters*.

*BNE3x-xx transceiver cable and BNE4x-xx office transceiver cable can be interconnected. However, the cable attenuation (signal loss) for the office transceiver cable is greater than that of BNE3x-xx transceiver cable by a factor of four. For example, 2 meters, 6.6 feet, of office transceiver cable is electrically equivalent to 8 meters, 26.2 feet, of BNE3x-xx transceiver cable.

If the configuration includes a device and the device has any internal cabling equivalency, this should be subtracted from the 50-meter maximum before dividing by 4. For example, if a device has a 10-meter cabling equivalency and is attached to its transceiver using office transceiver cable, then the maximum allowable transceiver length is $(50\text{ m} - 10\text{ m})/4$ or 10 meters.

- 2 When connecting the router to a configuration that includes a DELNI, allow 5-meters cabling equivalency loss for the DELNI.**
- 3 Maximum allowable lengths for device cables should not exceed guidelines set by RS-232-C (EIA232) specifications.**

3.4 Preinstallation Checks

Before beginning the router installation, use the following checklists to ensure that site preparation is complete:

Hardware

- The appropriate baseband or broadband network interface (for example, an Etherjack junction box, a DELNI, a DECOM, a DESTA, or Ethernet transceiver) is installed, and the required transceiver cabling is in place, tested, and tagged. If the device is not installed, ensure that arrangements for the installation are made before the router installation begins.
- The arrangements were made to connect the router's transceiver cable to the appropriate baseband or broadband network interface.
- The wall/partition mounting bracket kit or rack mount kit is installed (if required) as described in the kit documentation.
- The transceiver cables are available in the appropriate lengths.
- The device cables are available in the appropriate lengths or existing device cables you plan to use are available at the router installation site.
- The devices (personal computers, modems, hosts) are ready to be connected.
- At least one device with a keyboard (such as a terminal or a personal computer in terminal emulation mode) is available for installation troubleshooting, if necessary, and for system installation verification (as described in the appropriate DECrouter 200 Software Installation Guide).

Software

- The DECrouter 200 Identification Card was filled out (as described in section 3.1) and given to the system/network manager.
- The system/network manager installed or will install the distribution software on the load host(s).
- DECnet (Phase IV) is installed and running on the load host(s). (This does not apply to ULTRIX load hosts.)

Suitable Environment

The items listed in this checklist must conform to the specifications described in Appendix E of this guide.

- The power outlet matches the power requirements of the router you ordered and is within 1.8 meters (6 feet) of the installation site.
- The temperature, altitude, and humidity ranges are correct.
- The space is adequate for ventilation and for maintenance access.
- The location is at least 45 centimeters (18 inches) above the floor surface.

Service

- The service contracts (optional) are in place. See Appendix F for more information on service options.

4
DECrouter 200 Installation

4.1 Introduction

This chapter explains how to install, power up, and verify the operation of the DECrouter 200. Before you begin these procedures, read and follow the instructions in Chapter 3, Site Preparation. During this installation procedure, complete the instructions in each section before going on to the next section.

IMPORTANT

To avoid damage to the equipment, **DO NOT** connect the router power cord until instructed in the following procedures.

4.2 Verifying the Voltage Select Switch Setting

- 1 Locate the removable voltage label on the router's control/indicator panel.

Note the operating range indicated by the arrow on the label. This is the factory-set operating range of the router.

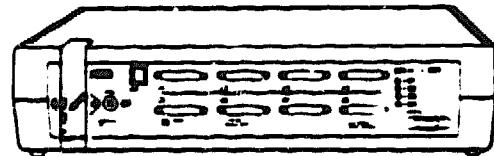

LKQ-0203

- 2 Peel the voltage label from the router, exposing the voltage select switch.

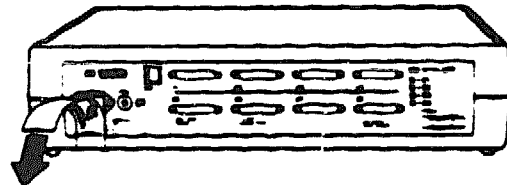

LKQ-0204

- 3 Verify that the voltage select switch is set to the operating range indicated by the label, and that this is the correct setting for your power source. (See your electrician if you are not sure.)

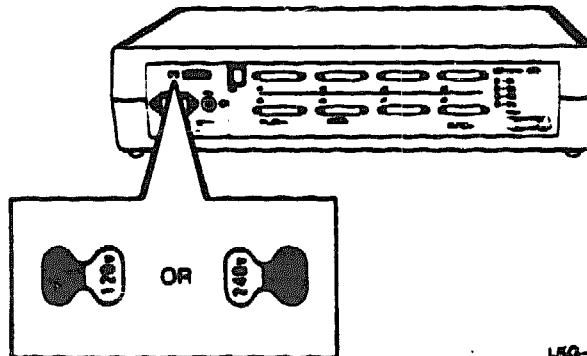

LKQ-0205

- 4 If the voltage setting is not correct for your power source, set the voltage select switch so match the power source voltage.

IMPORTANT

An incorrect voltage setting can damage the router.

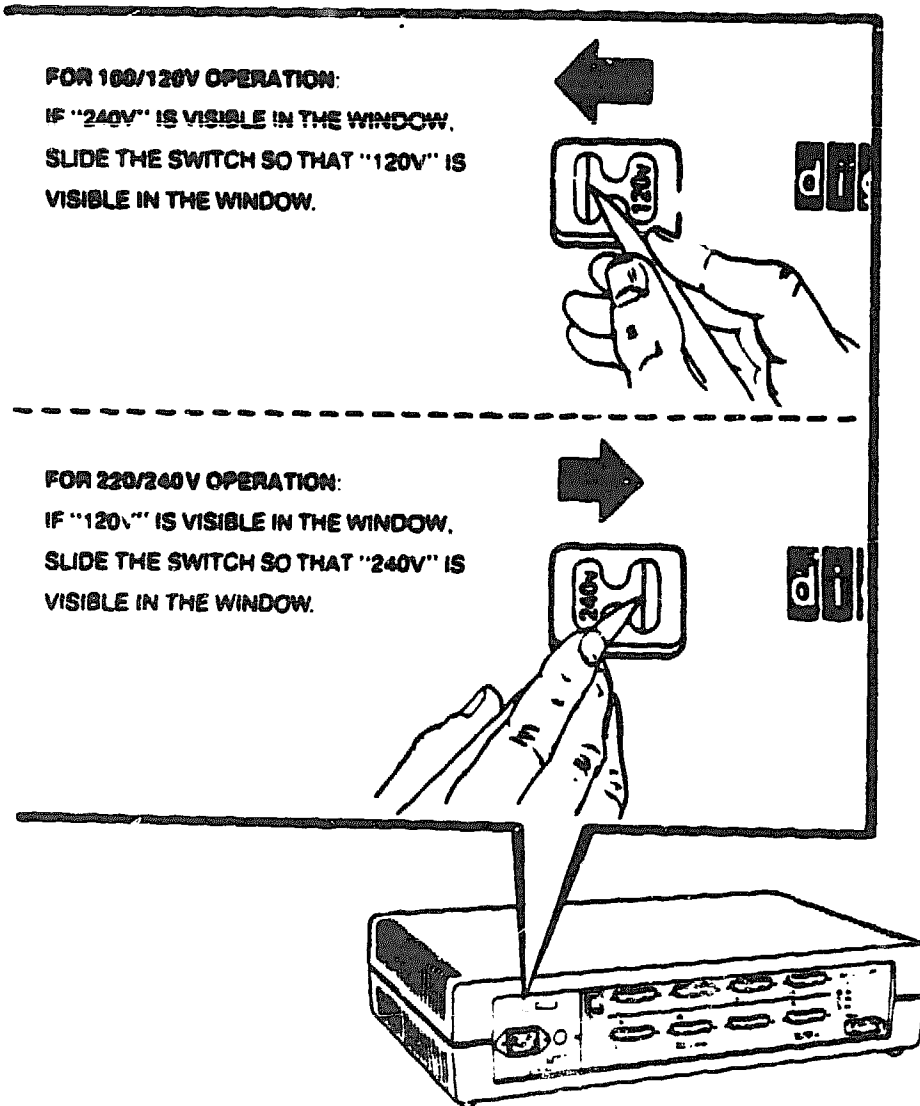

4.3 Connecting the Transceiver Cable

- 1 **Unlock the slide latch on the router's Ethernet connector.**

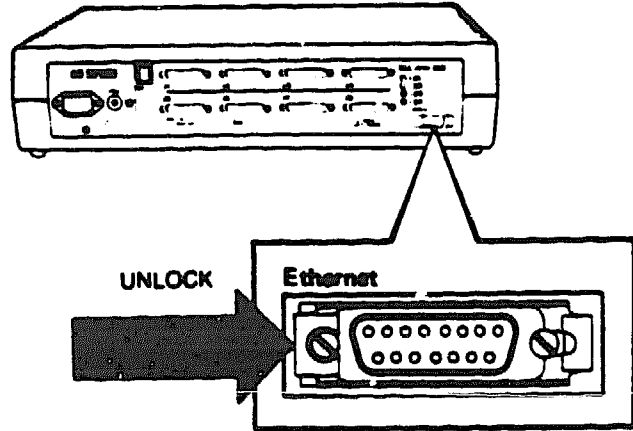

LKG-0337

- 2 **Connect the transceiver cable to the router's Ethernet connector. The cable can have a straight or a right-angle end connector.**

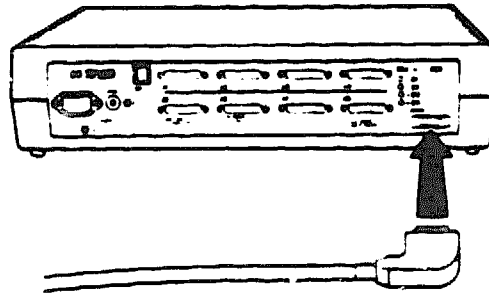

LKG-0343

- 3 **Lock the slide latch on the Ethernet connector.**

Tug gently on the cable to ensure it is securely connected.

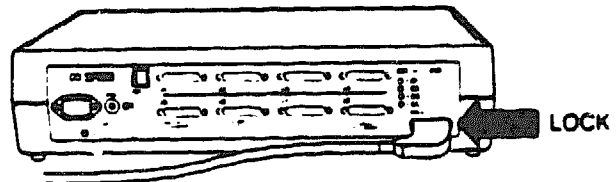

LKG-0339

-
- 4 Unlock the slide latch at the other end of the transceiver cable.

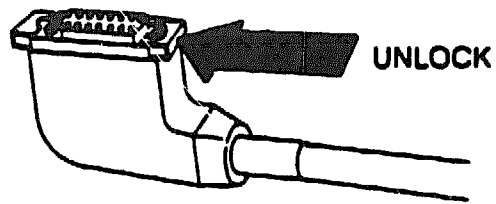

TW382

-
- 5 The other end of the transceiver cable connects to the appropriate baseband or broadband network interface. The connection is to one of the following:

- Another transceiver cable in an Etherjack junction box. See Appendix G for details on connecting to the Etherjack junction box.

Lock the slide latch after connecting the cable.

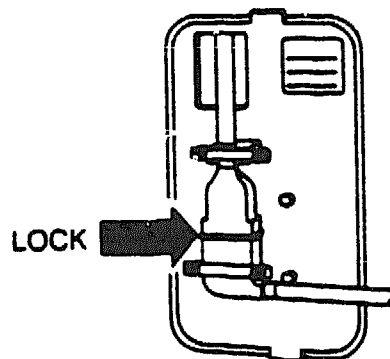

TW379

OR

- A cable port on a DELNI local network interconnect (as shown), or to a DECOM.

Lock the slide latch after connecting the cable.

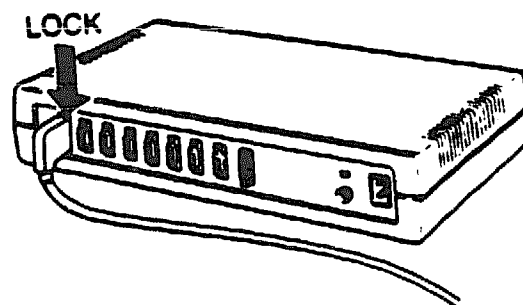

TW380

OR

-
- The cable port on an Ethernet Transceiver.
Lock the slide latch after connecting the cable.

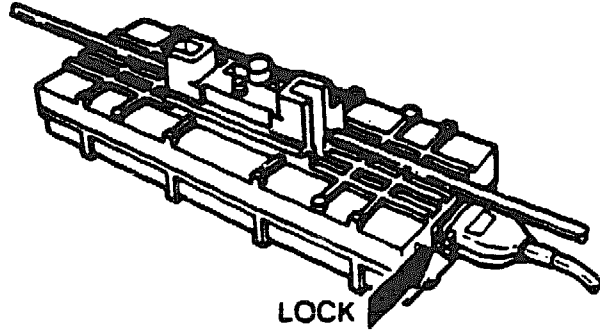

OR

LKG-0478

-
- The cable port on a DESTA ThinWire Ethernet station adapter.
Lock the slide latch after connecting the cable.

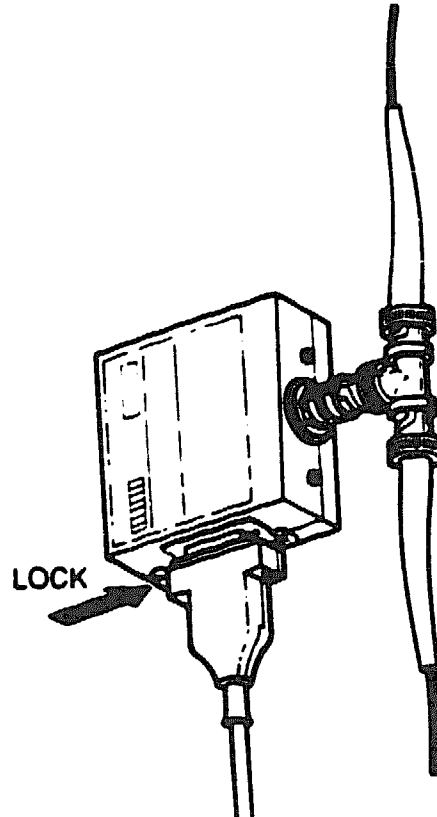

LKG-0480

4.4 Before Connecting Power

- 1 Make sure the transceiver cable connections are secure at both ends of the cable. If the transceiver cable is not connected when you plug in the power cord, the router will fail the diagnostic self-test.**
- 2 Check with your system manager that the software installation and the router configuration are complete. For example, the distribution software is installed on the load host(s), and the DECrouter 200 is configured in the load host database, if required by the load host(s).**

NOTE

If the distribution software installation is not complete, the load host cannot send the router image to the router. The router does not operate without software. Wait for notification that the software installation is completed.

4.5 Connecting Power

The router does not have a power ON/OFF switch. Plugging in the router power cord applies power directly to the router, illuminates the D1 Status LED, starts the router self-test, and allows the router image to be down-line loaded from a load host. The router self-test will fail if the transceiver cable is not connected.

To connect the router power cord, proceed as follows:

- 1 Plug one end of the power cord into the router power receptacle.

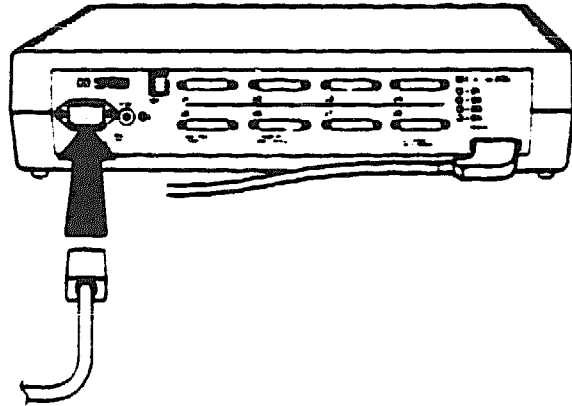

LKG-0344

- 2 Plug the other end of the power cord into the wall outlet.



TW387

4.6 Verifying Operation

Proper operation of the router is verified by the status of the four Light Emitting Diodes (LEDs) on the router's control/indicator panel.

- Whenever power is applied to the unit, the router performs a diagnostic self-test and initiates a request for a down-line load of the router image from a load host. The router self-test normally takes about 20 seconds to complete, but the down-line loading of the router image could take longer if the network is busy.

Allow up to 2 minutes for the router self-test and down-line loading of the router image to complete, then compare the state of the four status LEDs on the router with those shown in Figure 4-1:

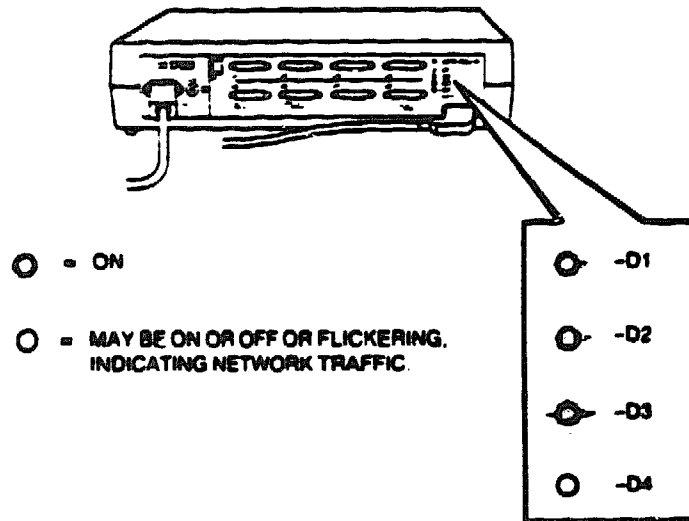

IF:
THE STATUS LEDs MATCH
THOSE SHOWN HERE.

THE STATUS LEDs DO NOT
MATCH THOSE SHOWN HERE.

THEN:
THE DECrouter 200 HARDWARE IS
FUNCTIONAL. GO TO SECTION 4.7
TO CONNECT DEVICE CABLES.

GO TO CHAPTER 5, WHAT TO DO
IF YOU HAVE PROBLEMS.

463-0233

Figure 4-1: DECrouter 200 Hardware Verification

NOTE

For definitions of the status LEDs on the router, see Appendix A.

4.7 Connecting Device Cables to the DECrouter 200

Before connecting the device cables to the router, contact the router manager to determine if certain devices were designated to specific ports on the router. Make a list that identifies the router, and the router port location for each device you connect to the router. Give the list to the router manager after connecting the device cables.

To connect the device cables to the DECrouter, proceed as follows:

- 1 Determine which router connector (J1 through J8) to use for each device.

Note that router ports (1 through 8) correspond to connectors (J1 through J8) on the DECrouter 200 control/indicator panel.

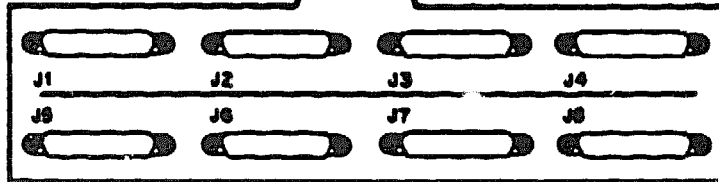
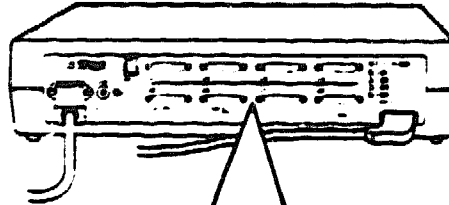

LKG-0346

- 2 Make two labels for each cable, marking each label with source and destination information similar to the sample label shown.

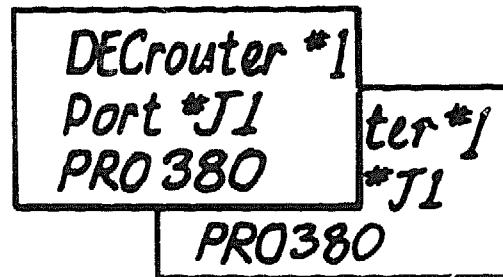

LKG-4020

-
- 3 Attach one label at both ends of each device cable.**

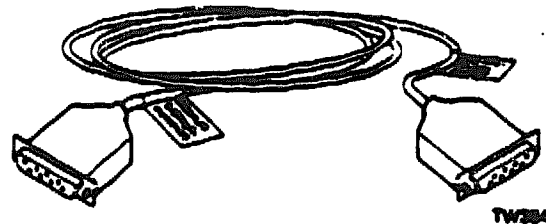

-
- 4 Connect one end of the cable to the appropriate device, as marked on the label.**

Tighten the connector screws.

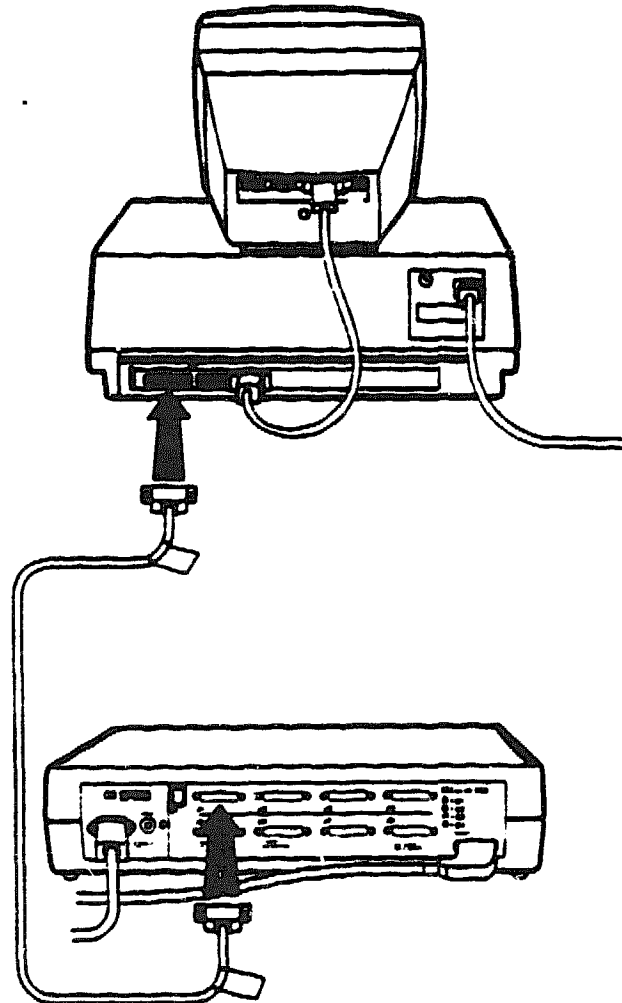

-
- 5 Connect the other end of the cable to the router connector marked on the label.**

Tighten the connector screws.

Install all other device cables in the same way. The number of cables you install depends on the number of devices you connect to the router.

After installing the device cables to all of your DECrouter 200 units, go to Section 4.8.

4.8 Verifying System Installation

After you install all of the DECrouter 200 units, inform the router manager that the router installation is complete. At this time the system installation verification (as described in the appropriate DECrouter 200 Software Installation Guide) should be performed on one of the DECrouter 200 hardware units. Also, provide the router manager with the list that shows the router port location for each device connected to the router.

5 What to Do if You Have Problems

5.1 Introduction

This chapter helps you identify and correct problems that can be encountered during the initial installation of the DECrouter 200. The troubleshooting procedures are for diagnosing and correcting hardware related problems only.

After diagnosing and correcting the problem, return to Section 4.6 to verify the correct operation of the router, then continue with the installation.

NOTE

Notify the router manager if the troubleshooting procedures indicate the problem is software related or if the procedures do not correct the problem. Additional troubleshooting information is provided in the *DECrouter 200 Management Guide*.

5.2 Diagnosing Router Problems

The four status LEDs, located on the router's control/indicator panel, indicate the status of the router and are also used for diagnosing router problems. Compare the state of the status LEDs on the router with those shown in Table 5-1 and go to the section indicated.

NOTE

All four status LEDs illuminate for 1 second (lamp check) whenever the router is powered up from a power-off state. After powering up the router, allow up to 2 minutes to elapse before determining the state of the status LEDs.

Table 5-1: Status LEDs/Indications

LED Name	LED Definition	State	Indications	Corrective Action
D1	Power ON/OFF	ON	The router's dc voltages are correct.	—
		OFF	The router's dc voltages are NOT correct.	Go to Section 5.3.
D2	Diagnostic	ON	Self-test passed.	—
		OFF	Fatal error if LED remains OFF within 2 minutes after power-up.	Go to Section 5.4.
		Blinking	Nonfatal error.	Go to Section 5.5.
D3	Software	ON	Router image successfully loaded.	—
		OFF	Down-line load in progress.	—
		Blinking	Multiple-load failure.	Go to Section 5.6.
D4	Network activity	ON*	Indicates activity on the network	—

* Can be ON or OFF or flickering, depending on the amount of traffic on the network.

5.3 D1 LED OFF

Problem Power is not reaching the DECrouter 200.

Correction Ensure that the voltage select switch is set to the correct voltage for your country. Section 4.2 in this guide provides information about changing the voltage setting, if necessary.

Correction Secure the power cable at the router and at the wall outlet.

Correction Check the wall outlet using another appliance or light, or plug the router power cord into another outlet. If no power is available, check the wall outlet's circuit breaker.

Correction Determine if the router circuit breaker has tripped (refer to Appendix A). If it has, press in on the white button to reset the breaker. If the circuit breaker trips more than once, notify the router manager that the router must be returned to Digital for repair or replacement. (Refer to the *DECrouter 200 Management Guide* for information about returning the unit to Digital.)

Correction Replace a defective router power cable with a new cable.

Problem The DECrouter 200 is defective.

Correction Notify the router manager that the router must be returned to Digital for repair or for replacement. (Refer to the *DECrouter 200 Management Guide* for information about returning the unit to Digital.)

5.4 D2 LED OFF

Problem A hardware error occurred that makes the DECrouter 200 nonoperational.

Correction There is no corrective procedure for this problem. Notify the router manager that the router must be returned to Digital for repair or for replacement. (Refer to the *DECrouter 200 Management Guide* for information about returning the unit to Digital.)

5.5 D2 LED Blinking

If the D2 LED is blinking after power-up, it indicates the router has a nonfatal problem detected during self-test. To isolate the problem, connect a console terminal to port 1 of the router. The primary problem indicator in this case is the error message that appears on the console terminal.

To isolate and diagnose the problem, do the following:

- 1 Connect a console terminal to port 1 of the router, then power up the terminal.
- 2 Configure the terminal to operate with a speed of 9600 bits per second and with a character size of 8 bits with no parity. (Refer to the specific terminal user's guide if you need help setting up the terminal parameters.)
- 3 Unplug the router power cord at the wall outlet, then reinsert it.
- 4 Read the error message that appears on the terminal display. (If no message appears on the terminal display, refer to Section 5.5.4.)

The following sections list the error messages that occur in conjunction with the D2 LED blinking. Locate the section that describes the displayed error message and follow the recommended corrective actions.

5.5.1 Error Messages 922 and 923

Local -922- Port hardware error on port *n*
Local -923- Port *n* has been disabled

Problem These messages indicate a port hardware error.

Correction There is no corrective procedure for this condition. Notify the router manager that the router must be returned to Digital for repair or for replacement. (Refer to the *DECrouter 200 Management Guide* for information about returning the unit to Digital.)

5.5.2 Error Message 932

Local -932- Hardware revision level checksum error

Problem The router's nonvolatile memory is faulty.

Correction There is no correction for this problem. Any performance enhancements based on hardware revisions are not operational. Notify the router manager that the router must be returned to Digital for repair or for replacement. (Refer to the *DECrouter 200 Management Guide* for information about returning the unit to Digital.)

5.5.3 Error Messages 941, 942, and 950

Local -941- Transceiver loopback error

Local -942- Image load not attempted

Local -950- Troubleshooting procedures should be followed

Problem There is a fault in the transceiver cabling between the router and the coaxial cable.

Correction First, check the transceiver cable that runs from the router to the transceiver, to the DELNI, or to the Etherjack. Ensure the connection is secure at both ends of the cable. Check the cable for any signs of damage. If the cable appears damaged, replace it.

Correction If the above actions do not correct the problem, use the Ethernet loopback connector (order code 12-22196-01) you received with the DECrouter 200 shipment, and do the following:

- 1 Disconnect the transceiver cable from the router.
- 2 Plug the Ethernet loopback connector into the Ethernet connector on the router.
- 3 Initialize the router by pressing **CTRL-P** on your console terminal, or by unplugging the router power cord from the wall outlet and then reinserting it.
- 4 Wait 20 seconds for the diagnostic test to complete, then observe the status of the D2 LED:
 - a. If the D2 LED continues to blink and the error messages reappear after the self-test (within 10 or 15 seconds), the router is faulty and must be returned to Digital for repair or for replacement. Notify the router manager.
 - b. If the D2 LED glows steadily, go to step 5 to isolate and to determine the faulty unit.

NOTE

When using the Ethernet loopback connector to troubleshoot the DECrouter 200, if the results cause the D2 LED to glow steadily, the router attempts to down-line load the router image. Since the router is disconnected from the network, the down-line load fails and the router responds by causing the D3 LED to blink and issues messages 902 and 912 to the console terminal.

- 5 Unplug the Ethernet loopback connector from the Ethernet connector on the router.
- 6 Reconnect the transceiver cable to the Ethernet connector on the router.
- 7 Disconnect the other end of the transceiver cable from the DELNI, from the Etherjack, or from the transceiver on the Ethernet coaxial cable.
- 8 Plug the Ethernet loopback connector into the transceiver cable.
- 9 Initialize the router by pressing **CTRL** on your console terminal, or by unplugging the router power cord from the wall outlet and then reinserting it.
 - a. If the D2 LED continues to blink, the transceiver cable is faulty and must be replaced.
 - b. If the D2 LED glows steadily, the faulty unit is the device that the transceiver cable was connected to (the DELNI, the Etherjack extension, the DECOM, the DESTA, or the transceiver). Notify the router manager so that arrangements can be made for repair or for replacement of the faulty device.

5.5.4 No Messages on Console Terminal

The console terminal has no display when the router initializes.

Problem The port to which the console terminal is physically connected is not defined as the console port.

Correction Ensure the console terminal is physically connected to port 1 on the router.

Problem The console terminal is faulty.

Correction Replace the console terminal with another and set the device parameters as described at the beginning of Section 5.5.

Problem The internal characteristics for the console terminal are not set up correctly.

Correction Reset the internal characteristics for the console terminal as described at the beginning of Section 5.5.

NOTE

For router installation, the console terminal must be configured to operate with a speed of 9600 bits per second and with a character size of 8 bits with no parity.

5.6 D3 LED Blinking

If the D3 LED is blinking after power-up, it indicates the router has a down-line loading problem. To isolate and to diagnose the problem, do the following:

- 1 Connect a terminal to port 1 of the router, then power up the terminal.
- 2 Configure the terminal to operate with a speed of 9600 bits per second and a character size of 8 bits with no parity (refer to the specific terminal user's guide if you need help setting up the terminal parameters).
- 3 Press **CTRL-P** on the console terminal keyboard. Pressing **CTRL-P** restarts the router self-test and starts the down-line loading of the router image from a load host.
- 4 Read the message that appears on the terminal display.

NOTE

If the down-line load succeeds, the terminal displays a message indicating the load is complete. The load-complete message can be followed by a series of (coded) alphabetic characters that represent DDCMP protocol messages issued from port 1 of the DECrouter 200. This is normal.

- The following order of 900-series messages on the console terminal indicate down-line loading problems. Each is covered in the following sections.

5.6.1 Down-Line Load Starts, Then Falls

The following sequence of messages appears on the console terminal at various time intervals:

Local -902- Waiting for image load
Local -903- Loading from host *host-address*
Local -912- Load failure, timeout

Problem The host system (addressed in error message) failed to complete the down-line load to the router.

Correction Copy the error message exactly as it appears on the console terminal display and notify the router manager.

5.6.2 Down-Line Load Does Not Start

The following sequence of messages appears on the console terminal at various time intervals:

Local -902- Waiting for image load
Local -912- Load failure, timeout

Problem Load host(s) not responding to router down-line load request within the allotted timeout period.

Correction Copy the error message exactly as it appears on the console terminal display and notify the router manager.

A

Controls and Indicators

This appendix describes the DECrouter 200 controls and indicators.

A.1 Controls

All the DECrouter 200 controls are located on the router's control/indicator panel (see Figure A-1). There are no user controls inside the router.

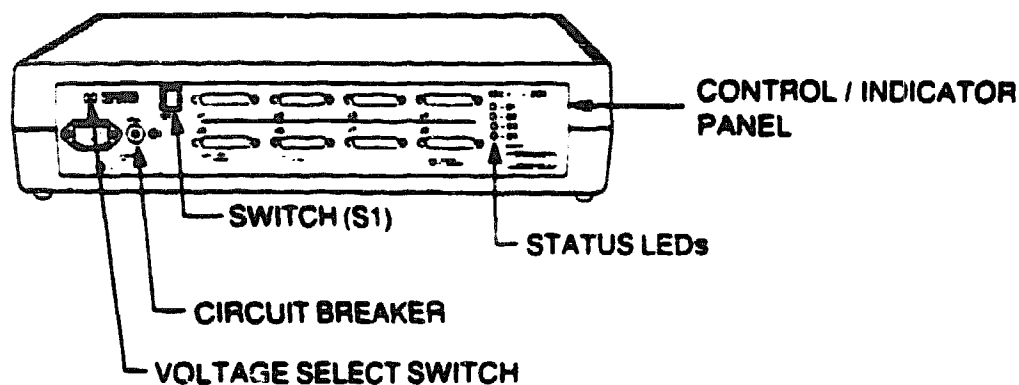

LKG-0521

Figure A-1: Controls and Indicators

A.1.1 Switch (S1)

Switch (S1), located on the router's control/indicator panel, serves no function for the DECrouter 200.

A.1.2 Voltage Select Switch

The voltage select switch is used to set the router input voltage to the range required for operation in your country. This switch was factory set for the correct power source for your country. Do not change this switch unless you are sure that the switch setting is incorrect (see your electrician if you are not sure). Section 4.2 provides information about changing the router voltage setting, if necessary.

A.1.3 Circuit Breaker

The circuit breaker provides overcurrent protection for the router. If an overcurrent condition within the router causes the circuit breaker to trip, the white center portion of the circuit breaker pops out as a visual indication, and the ac power is cut off from the router. The circuit breaker can be reset by pressing in on the white center portion of the breaker.

IMPORTANT

If the circuit breaker trips, do NOT attempt to reset it more than once. Contact Digital Field Service or return the unit to Digital for repair.

A.2 Status Indicator LEDs

There are four status indicator LEDs (Light Emitting Diodes) located on the router's control/indicator panel. They are defined in Table A-1, as follows:

Table A-1: Status LEDs

LED Name	LED Definition	State	Indications
D1	Power ON/OFF	ON	The router's dc voltages are correct.
		OFF	The router's dc voltages are NOT correct.
D2	Diagnostic	ON	Self-test passed.
		OFF	Fatal error or test-in-progress.
		Blinking	Nonfatal error.
D3	Software	ON	Router image successfully loaded.
		OFF	Down-line load in progress.
		Blinking	Multiple-load failure.
D4	Network activity	ON*	Indicates activity on the network.

* Can be ON or OFF or flickering, depending on the amount of traffic on the network.

B

Port Devices Supported by DECrouter 200

This appendix lists port devices supported by DECrouter 200. For the latest listing of supported devices, see the DECrouter 200 Software Product Description that applies to your operating system.

Devices supported by DECrouter 200 include:

- **Personal Computers — DECrouter 200 supports Digital and non-Digital personal computers running DECnet Phase IV.**

Digital personal computers supported by DECrouter 200 include:

- Professional 300 series
- Rainbow 100 series

Non-Digital personal computers supported by DECrouter 200 include:

- IBM PC, IBM PC/XT, and IBM Personal Computer AT

- **Modems — DECrouter 200 provides full-duplex modem control and supports all asynchronous, full-duplex Digital modems in both dial-in and dial-out modes.**

Digital modems supported by DECrouter 200 include:

- DF02 (300 bps)
- DF03 (300/1200 bps)
- DF112 (300/1200 bps)
- DF124 (1200/2400 bps)
- DF224 (300/600/1200/2400 bps)

Non-Digital modems supported by DECrouter 200 include modems compatible with Bell 103J and Bell 212A, and modems that conform to CCITT V.21, V.21 bis, V.22, and V.22 bis.

C **Ordering Information**

This appendix lists order codes for DECrouter 200 related hardware products. See your Digital sales representative to purchase equipment.

For a listing of software options, see the DECrouter 200 Software Product Description that applies to your operating system.

C.1 DECrouter 200 Hardware Units

Description	Order Code
DECrouter 200	
120 Vac (includes DSRVC-KA country kit)	DSRVC-AA
240 Vac	DSRVC-AB

C.2 DECrouter 200 Country Kits

Each kit includes a power cord, the documentation, an Ethernet loopback connector, and a rack mount kit. (You will need one kit for each DECrouter 200.)

Country	Order Code
Australia	DSRVC-KZ
Belgium	DSRVC-LA
Canada (English and French)	DSRVC-KA
Denmark	DSRVC-KD
Finland	DSRVC-LA
France	DSRVC-LA
Germany	DSRVC-KG
Holland	DSRVC-LA
Italy	DSRVC-KI
India	DSRVC-LJ
Israel	DSRVC-KT
Japan	DSRVC-KJ
New Zealand	DSRVC-KZ
Norway	DSRVC-LA
Spain	DSRVC-LA
Sweden	DSRVC-LA

(continued on next page)

Country	Order Code
Switzerland (French and German)	DSRVC-LB
United Kingdom	DSRVC-KE
United States	DSRVC-KA

C.3 DECrouter 200 Accessories

Description	Order Code
Ethernet turnaround connector — For testing transceiver and transceiver cable.	H4080
Ethernet loopback connector — For loopback testing the DECrouter 200 Ethernet port and transceiver cable.	12-22196-01
Port loopback connector — For loopback testing the DECrouter 200 device ports.	12-15336-08
Etherjack kit — For covering and securing transceiver cable connections.	DEXJK
Wall/partition mounting bracket kit — For mounting the DECrouter 200 to walls or office partitions.	H039
Rack mount kit — For mounting the DECrouter 200 in standard rack cabinets.	H041-AA

C.4 Transceiver Cables

BNE3x-xx transceiver cable — Available in FEP versions, for use in return air conduits, and in PVC versions, for use in nonenvironmental airspaces. The large diameter of this cable results in a lower signal loss per length of cable than the smaller diameter office transceiver cable. Two styles of connectors are available: a straight connector and a right-angle connector.

The following cables are available:

- **BNE3A-xx PVC, straight-connector transceiver cable**
- **BNE3B-xx PVC, right-angle connector transceiver cable**
- **BNE3C-xx FEP, straight-connector transceiver cable**
- **BNE3D-xx FEP, right-angle connector transceiver cable**
- **BNE3H-xx PVC, straight-connector, 802.3-compliant transceiver cable**
- **BNE3K-xx PVC, right-angle connector, 802.3-compliant transceiver cable**
- **BNE3L-xx FEP, straight-connector, 802.3-compliant transceiver cable**

- **BNE3M-xx FEP, right-angle connector, 802.3-compliant transceiver cable**

The preceding cables are available in 5 meters (16.4 feet), 10 meters (32.8 feet), 20 meters (65.6 feet), and 40 meters (131.2 feet) lengths.

BNE4x-xx office transceiver cable — Available in PVC versions for use in nonenvironmental airspaces. The smaller diameter of this cable makes it ideal for use in office environments, however the smaller diameter of the cable also results in a cable signal loss that is four times greater than that of BNE3x-xx transceiver cables. Two styles of connectors are available: a straight connector and a right-angle connector.

The following cables are available:

- **BNE4A-xx PVC, straight-connector transceiver cable**
- **BNE4B-xx PVC, right-angle connector transceiver cable**
- **BNE4C-xx PVC, straight-connector, 802.3-compliant transceiver cable**
- **BNE4D-xx PVC, right-angle connector, 802.3-compliant transceiver cable**

The preceding cables are available in 2 meters (6.6 feet) and 5 meters (16.4 feet) lengths.

C.5 Device Cables

The following device cables are available:

Null modem cable, round, 10-wire, fully shielded, EIA RS-232-C/CCITT V.28, female-to-female molded connectors

Length	Order Code
02 ft (0.6 m)	BC17D-02
10 ft (3.0 m)	BC17D-10
25 ft (7.6 m)	BC17D-25
50 ft (15.2 m)	BC17D-50
100 ft (30.5 m)	BC17D-A0

Null modem cable, round, 6-wire, fully shielded, EIA RS-232-C/CCITT V.28, female-to-female molded connectors

Length	Order Code
10 ft (3.0 m)	BC22D-10
25 ft (7.6 m)	BC22D-25
35 ft (10.7 m)	BC22D-35
50 ft (15.2 m)	BC22D-50

(continued on next page)

Length	Order Code
75 ft (22.9 m)	BC22D-75
100 ft (30.5 m)	BC22D-A0
150 ft (45.7 m)	BC22D-A5
200 ft (61.0 m)	BC22D-B0
250 ft (76.2 m)	BC22D-B5

Modem cable, round, 16-wire, fully shielded, EIA RS-232-C/CCITT V.28, male-to-female molded connectors

Length	Order Code
10 ft (3.0 m)	BC22E-10
25 ft (7.6 m)	BC22E-25
35 ft (10.7 m)	BC22E-35
50 ft (15.2 m)	BC22E-50
75 ft (22.9 m)	BC22E-75
100 ft (30.5 m)	BC22E-A0
150 ft (45.7 m)	BC22E-A5
200 ft (61.0 m)	BC22E-B0
250 ft (76.2 m)	BC22E-B5

Full modem cable, round, 25-wire, fully shielded, EIA RS-232-C/CCITT V.28, male-to-female molded connectors

Length	Order Code
10 ft (3.0 m)	BC22F-10
25 ft (7.6 m)	BC22F-25
35 ft (10.7 m)	BC22F-35
50 ft (15.2 m)	BC22F-50
75 ft (22.9 m)	BC22F-75
100 ft (30.5 m)	BC22F-A0
150 ft (45.7 m)	BC22F-A5
200 ft (61.0 m)	BC22F-B0
250 ft (76.2 m)	BC22F-B5

D **Cable Structure**

This appendix describes the electrical interface used on the DECrouter 200. Wiring diagrams of the individual device cables are provided for use in troubleshooting or for cable building. These cables can be ordered from Digital. See Appendix C for ordering information.

D.1 DECrouter 200 Device Connectors (J1 through J8)

The control/indicator panel of the DECrouter 200 contains a bank of eight 25-pin D-subconnectors (J1 through J8) used to connect devices to the router ports. Although all 25 pins are populated on each connector, only 11 pins are used (see Table D-1).

The pin numbers for these connectors, as viewed from the router's control/indicator panel, are shown in Figure D-1.

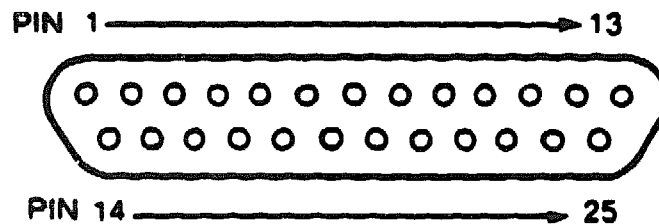

UKG-0390

Figure D-1: Pin Numbers — DECrouter 200 Device Connectors (J1 through J8)

D.2 Serial Line Circuit Standards

DECrouter 200 pin signals conform to the following serial line circuit standards (Ref: ISO 2110) shown in Table D-1.

Table D-1: Circuit Standards

Pin	Signal	Source	Description	(EIA232) RS-232-C	CCITT V.28
2	TXD	DTE	Transmitted Data	BA	103
3	RXD	DCE	Received Data	BB	104
4	RTS	DTE	Request to Send	CA	105
5	CTS	DCE	Clear to Send	CB	106
6	DSR	DCE	Data Set Ready	CC	107
7	GND	—	Signal Ground	AB	102
8	CD	DCE	Carrier Detect	CF	109
12	SMI	DCE	Speed Mode Indicate	CI	112
20	DTR	DTE	Data Terminal Ready	CD	108.2
22	RI	DCE	Ring Indicator	CE	125
23	DSRS	DTE	Data Signal Rate Select	CH	111

D.3 DECrouter 200 Device Cables

The cables described in the following sections are used to connect devices to the DECrouter 200.

D.3.1 BC17D Shielded Null Modem Cable

The BC17D cable is used for directly connecting DECrouter 200 device ports to devices that use modem control signal for operation.

Figure D-2 shows the DECrouter 200 pin numbers and signals that are used with the BC17D shielded null modem cable.

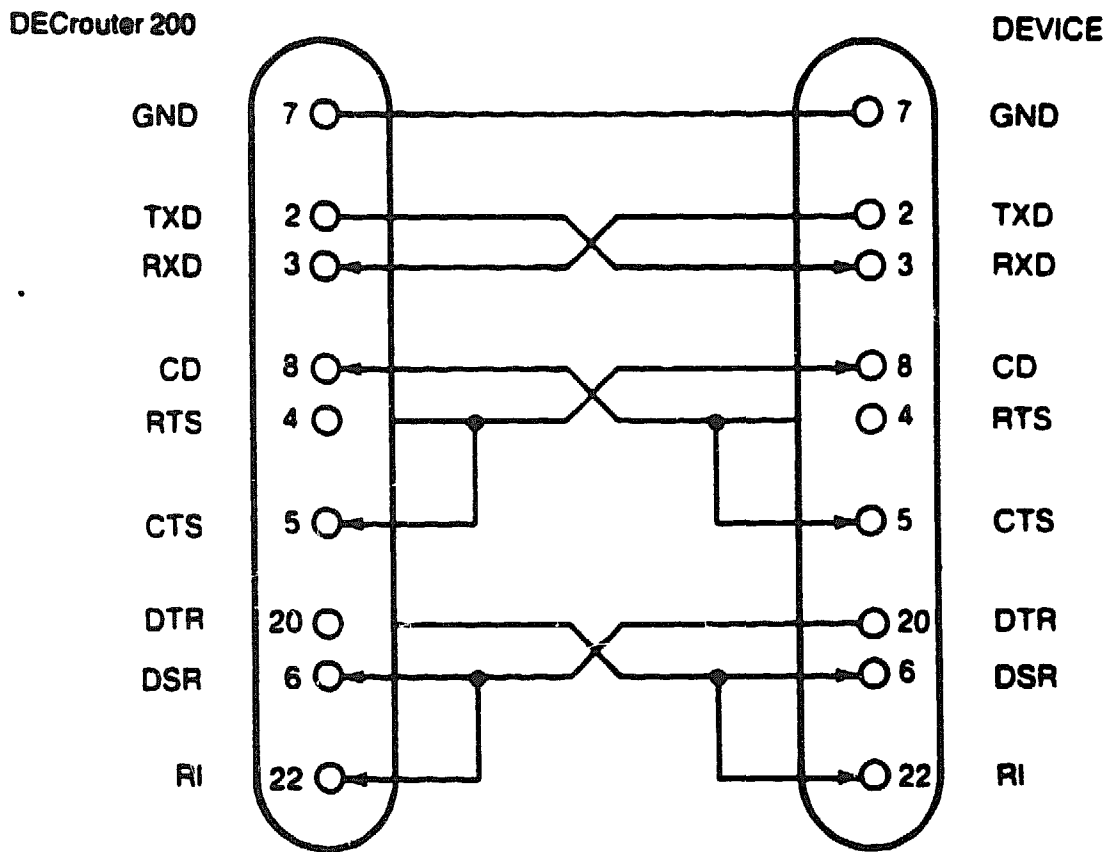

LKG-0517

Figure D-2: Pin Assignments — BC17D Shielded Null Modem Cable

D.3.2 BC22D Shielded Null Modem Cable (Data Leads Only)

The BC22D cable is used for directly connecting DECrouter 200 device ports to devices that do not require modem control signal for operation.

Figure D-3 shows the DECrouter 200 pin numbers and signals used with the BC22D shielded null modem cable.

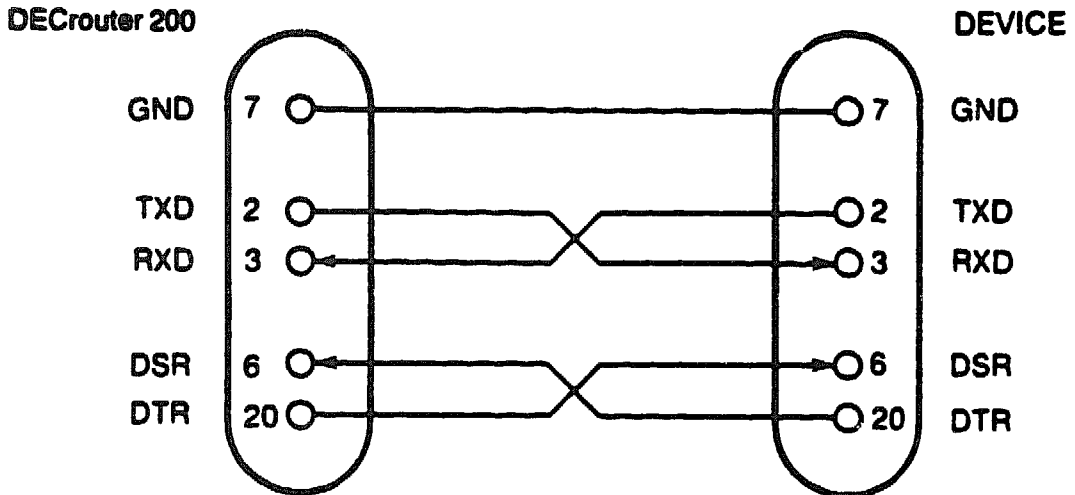

LKG-0519

Figure D-3: Pin Assignments — BC22D Shielded Null Modem Cable

D.3.3 BC22E or BC22F Shielded Straight-Through Cable (Full-Modem)

The BC22E or BC22F cable is used for connecting the DECrouter 200 device ports to modems (or modem-equivalent devices).

Figure D-4 shows the DECrouter 200 pin numbers and signals used with the BC22E or BC22F shielded straight-through cable.

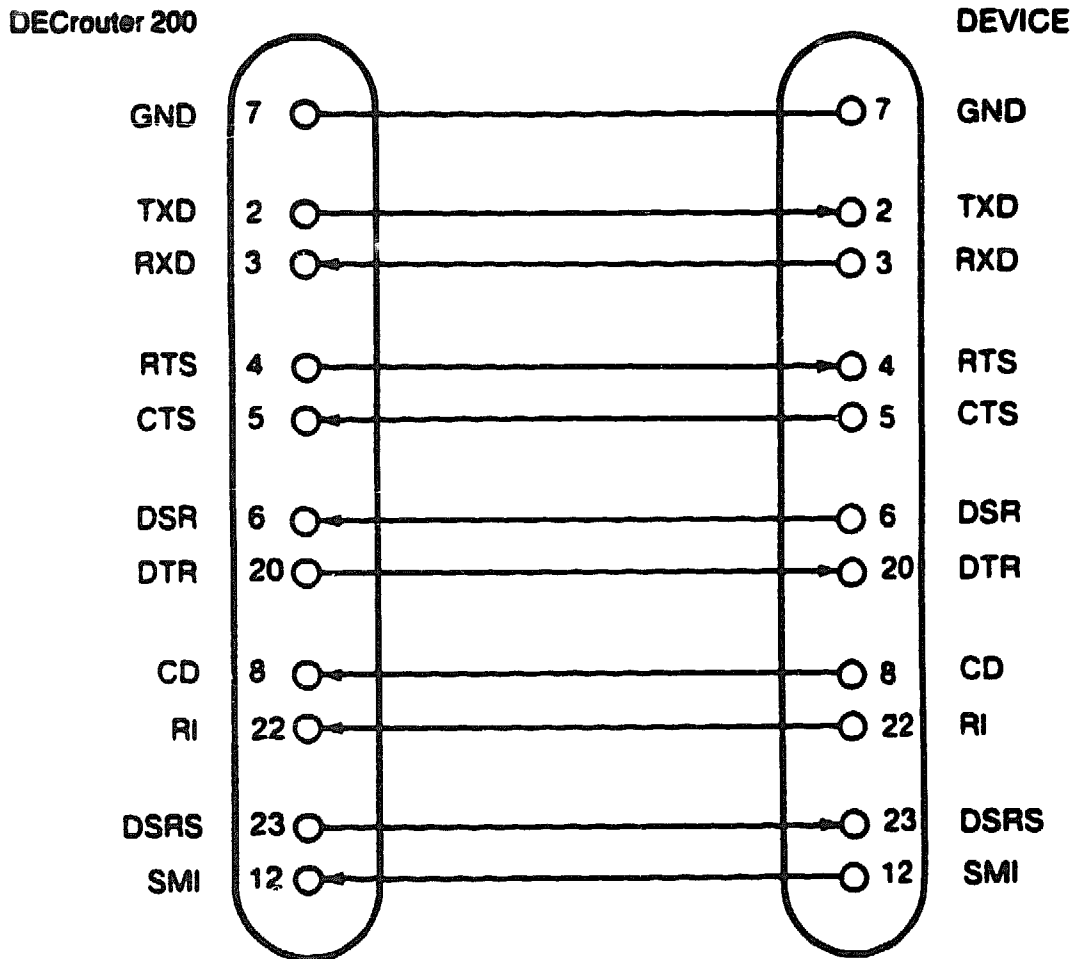

LKG-0518

Figure D-4: Pin Assignments — BC22E or BC22F Shielded Straight-Through Cable

D.3.4 DECrouter 200 Port Loopback Connector

The DECrouter 200 port loopback connector is used to troubleshoot the DECrouter 200 ports (as explained in the *DECrouter 200 Management Guide*).

Figure D-5 shows the wiring diagram of the port loopback connector and the corresponding signals looped back to the DECrouter 200.

DECrouter 200

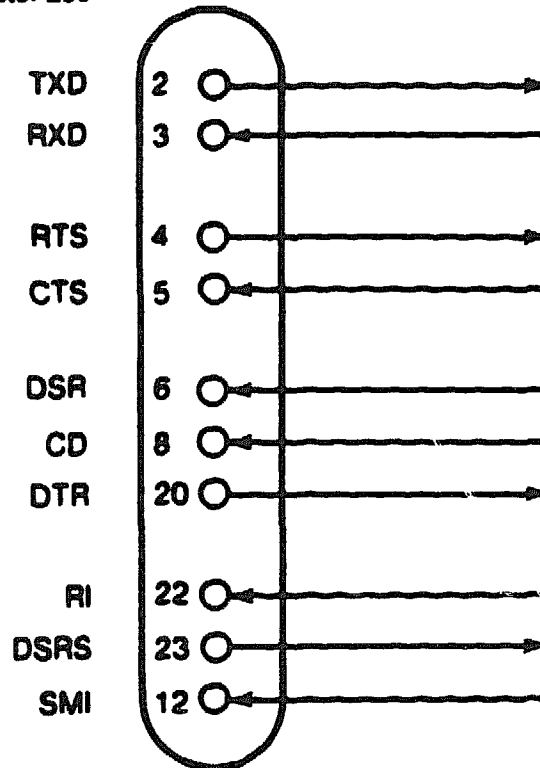

LKG-0620

Figure D-6: Wiring Diagram -- DECrouter 200 Port Loopback Connector

E **DECrouter 200 Specifications**

This appendix lists the DECrouter 200 specifications.

E.1 Power

The power requirements for the DECrouter 200 are shown in Table E-1.

Table E-1: DECrouter 200 Power Ratings

Requirements	DSRVC-AA	DSRVC-AB
Factory-set nominal voltage	100 Vac to 120 Vac 3-wire, single phase	220 Vac to 240 Vac 1N + PE
Frequency	47 Hz to 63 Hz	47 Hz to 63 Hz
Line current	1.0 A	0.5 A
Power	75 watts	75 watts

Most wall outlets meet one of these sets of requirements. However, you should check with an electrician to make sure the line is grounded (earthed).

E.2 Environment

E.2.1 Temperature

Operating: 5° C to 50° C (41° F to 122° F)

Nonoperating: -40° C to 66° C (-40° F to 151° F)

Maximum temperature change per hour: 20° C (36° F)

Rapid temperature changes can affect operation. Therefore, do not operate the router near heating or cooling devices, large windows, or doors that open to the outside.

IMPORTANT

The router must be at operating temperature before you install it. If, during transit, the router is exposed to temperatures above or below the operating temperature, leave the router overnight in the operating environment before operating it.

E.2.2 Altitude

Operating: 2.4 km (8000 ft)

Nonoperating: 9.1 km (30,000 ft)

If you are operating the router above 2.4 kilometers, decrease the operating temperature by 1.8° Centigrade/1000 meters (1° Fahrenheit/1000 feet).

E.2.3 Relative Humidity

Operating: 10% to 95% (noncondensing)

Nonoperating: 95% maximum

Low humidity can cause static electricity that can affect router operation. Use a humidifier to correct the problem.

E.2.4 Physical Size of the DECrouter 200

Width: 49.3 cm (19.4 in)

Height: 11.7 cm (4.6 in)

Depth: 31.2 cm (12.3 in)

Weight: 5.9 kg (13.0 lb)

E.2.5 Space Requirements

Allow for 15 centimeters (6 inches) of airspace around the router air vents, and place the router at least 45 centimeters (18 inches) above the floor. This allows adequate ventilation for cooling fans and reduces exposure to excess dust from foot traffic.

F
Service Options

This appendix briefly describes the Digital hardware and software service options that are available to support the DECrouter 200. For more information about Digital services, please contact your Digital sales representative.

F.1 Hardware Services

F.1.1 Digital On-Site Service

Digital provides on-site service under a service agreement or on a per-call basis. Trained service specialists perform hardware maintenance at your site.

F.1.2 DECmailer

DECmailer allows you to ship the router to a Customer Return Center for repair.

F.2 Installation Service

Installation service includes services provided by trained service specialists for successful installation of your DECrouter 200

F.3 Software Services

F.3.1 Software Product Service Agreements

Digital offers software product service agreements to support your software. See your Digital sales representative for more details.

F.3.2 Training

Digital Educational Services sells training for installation, maintenance, and management of Digital software. Course formats may vary from seminars to packaged training materials.

G Connecting to Etherjack

This appendix explains how to connect the router transceiver cable to another transceiver cable mounted in an Etherjack junction box. If the Etherjack junction box has not been installed, install it now before continuing with this procedure. Follow the installation instructions you received with the unit.

To connect your router transceiver cable to the Etherjack junction box, proceed as follows:

- 1 Remove the Etherjack cover by lifting the top of the cover slightly, then pulling it back.

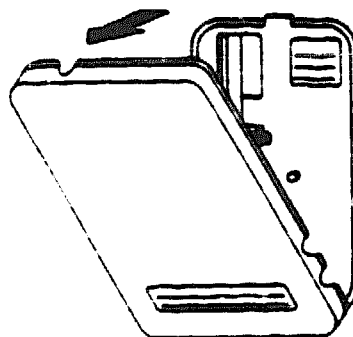

TW281

- 2 Using a flat-blade screwdriver, remove the 2 screws securing the larger retainer bracket, and remove the bracket.

The transceiver cable mounted inside can have a straight or a right-angle connector.

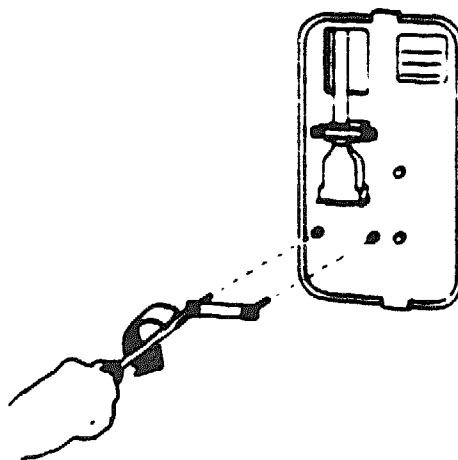

TW281

- 3 Unlock the slide latch on the router transceiver cable.

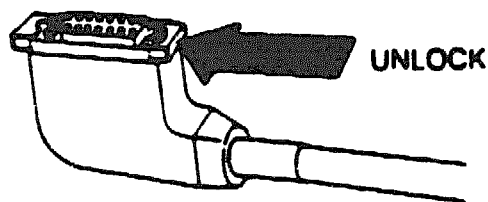

TW282

- 4 Connect the router transceiver cable to the Etherjack transceiver cable. Note the four possible combinations of straight and right-angle connectors:

Both right-angle connectors

OR

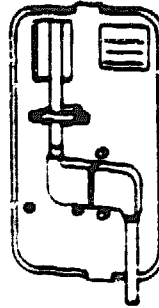

TW383

Right-angle connector to straight connector

OR

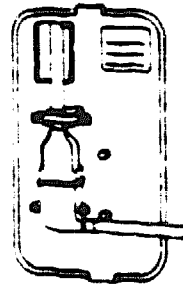

TW384

Both straight connectors

OR

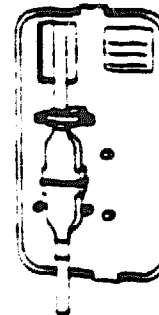

TW385

Straight connector to right-angle connector

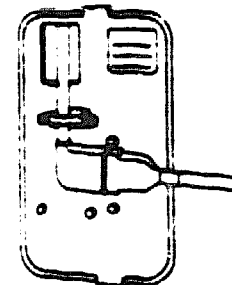

TW386

-
- 5** Push the slide latch on the router transceiver cable connector until the connectors are locked securely.

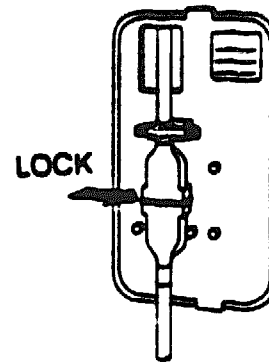

TW387

-
- 6** Replace the large retainer bracket and the 2 screws. Tighten the 2 screws with the flat-blade screwdriver.

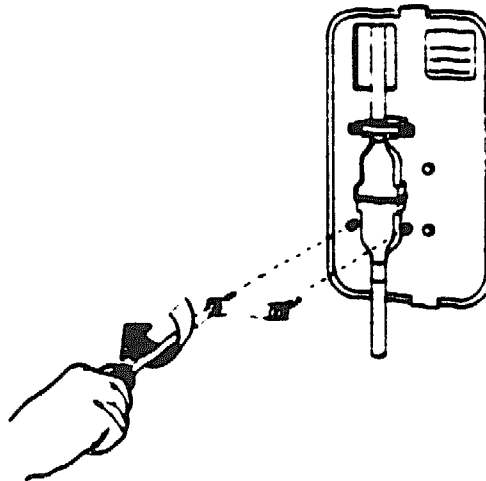

TW400

-
- 7** Replace the Etherjack cover, ensuring the cables protrude through the slots provided in the cover. Push the top of the cover over the tab in the backplate until it locks in place.

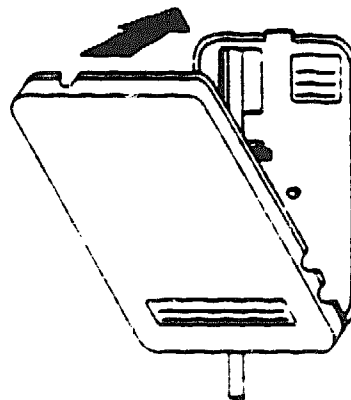

TW388